

DIGITAL AMPLIFIER POWER STAGE



FEATURES

- 50 W per Channel (BTL) Into 6 Ω (Stereo)
- 95-dB Dynamic Range With TAS5026
- Less Than 0.1% THD+N (1 W RMS Into 6 Ω)
- Less Than 0.2% THD+N (50 W RMS into 6 Ω)
- Power Efficiency Typically 90% Into 6-Ω Load
- Self-Protecting Design (Undervoltage, Overtemperature and Short Conditions) With Error Reporting
- Internal Gate Drive Supply Voltage Regulator
- EMI Compliant When Used With Recommended System Design

APPLICATIONS

- DVD Receiver
- Home Theatre
- Mini/Micro Component Systems
- Internet Music Appliance

DESCRIPTION

The TAS5112A is a high-performance, integrated stereo digital amplifier power stage designed to drive 6-Ω speakers at up to 50 W per channel. The device incorporates TI's PurePath Digital™ technology and is used with a digital audio PWM processor (TAS50XX) and a simple passive demodulation filter to deliver high-quality, high-efficiency, true-digital audio amplification.

The efficiency of this digital amplifier is typically 90%, reducing the size of both the power supplies and heatsinks needed. Overcurrent protection, overtemperature protection, and undervoltage protection are built into the TAS5112A, safeguarding the device and speakers against fault conditions that could damage the system.

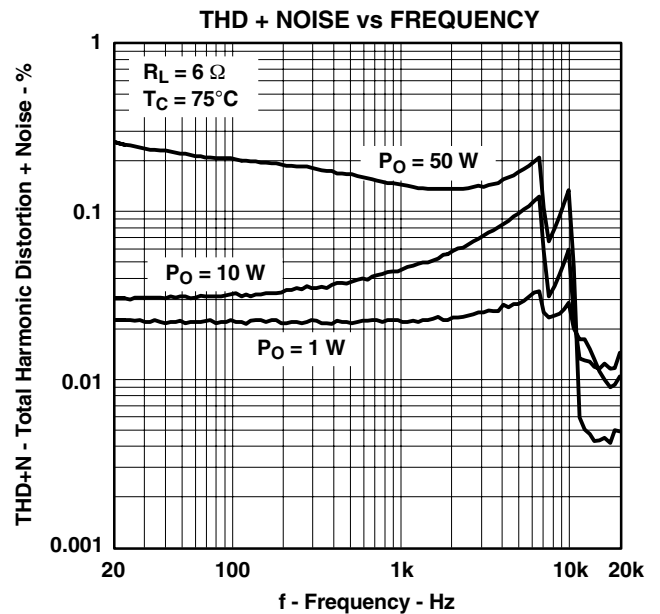
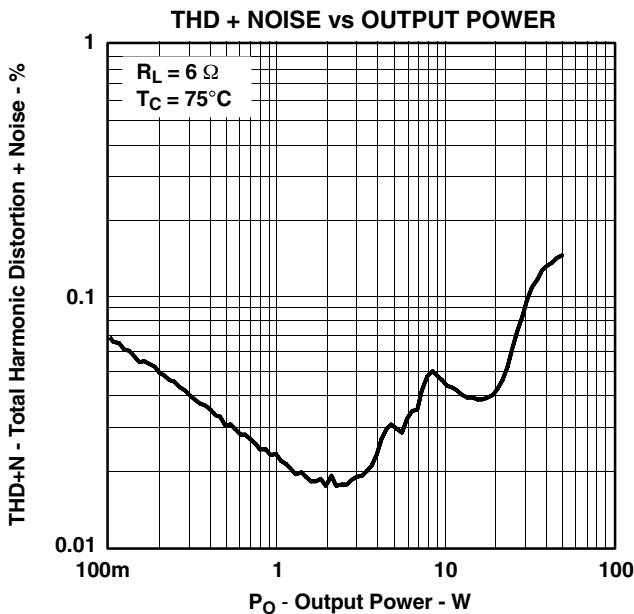

Please be aware that an important notice concerning availability, standard warranty, and use in critical applications of Texas Instruments semiconductor products and disclaimers thereto appears at the end of this data sheet.

PurePath Digital and PowerPAD are trademarks of Texas Instruments. Other trademarks are the property of their respective owners.

TAS5112A

SLES094B - OCTOBER 2003 - REVISED JUNE 2008



These devices have limited built-in ESD protection. The leads should be shorted together or the device placed in conductive foam during storage or handling to prevent electrostatic damage to the MOS gates.

GENERAL INFORMATION

Terminal Assignment

The TAS5112A is offered in a thermally enhanced 56-pin TSSOP DFD (thermal pad is on the top) and DCA (thermal pad is on the bottom), shown as follows.

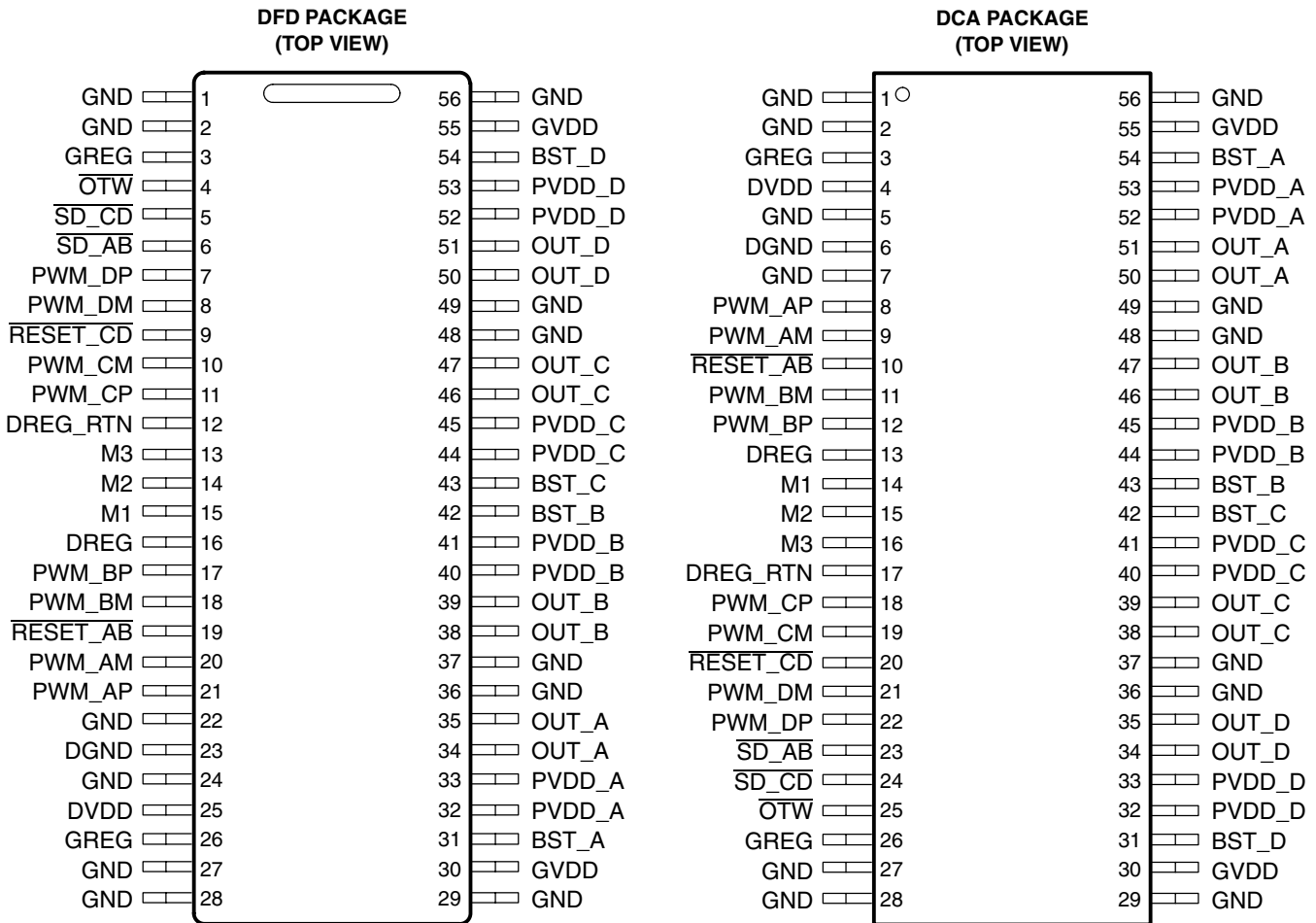

Absolute Maximum Ratings

over operating free-air temperature range unless otherwise noted⁽¹⁾

TAS5112A	UNITS
DVDD TO DGND	-0.3 V to 4.2 V
GVDD TO GND	33.5 V
PVDD_X TO GND (dc voltage)	33.5 V
PVDD_X TO GND (spike voltage ⁽²⁾)	48 V
OUT_X TO GND (dc voltage)	33.5 V
OUT_X TO GND (spike voltage ⁽²⁾)	48 V
BST_X TO GND (dc voltage)	48 V
BST_X TO GND (spike voltage ⁽²⁾)	53 V
GREG TO GND ⁽³⁾	14.2 V
PWM_XP, RESET, M1, M2, M3, SD, OTW	-0.3 V to DVDD + 0.3 V
Maximum operating junction temperature, T _J	-40°C to 150°C
Storage temperature	-40°C to 125°C

- (1) Stresses beyond those listed under “absolute maximum ratings” may cause permanent damage to the device. These are stress ratings only, and functional operation of the device at these or any other conditions beyond those indicated under “recommended operating conditions” is not implied. Exposure to absolute-maximum-rated conditions for extended periods may affect device reliability.
- (2) The duration of voltage spike should be less than 100 ns; see application note SLEA025.
- (3) GREG is treated as an input when the GREG pin is overdriven by GVDD of 12 V.

Package Dissipation Ratings

PACKAGE	R _{θJC} (°C/W)	R _{θJA} (°C/W)
56-pin DFD TSSOP	1.14	See Note 4
56-pin DCA TSSOP	1.14	See Note 4

- (4) The TAS5112A package is thermally enhanced for conductive cooling using an exposed metal pad area. It is impractical to use the device with the pad exposed to ambient air as the only heat sinking of the device.

For this reason, R_{θJA}, a system parameter that characterizes the thermal treatment, is provided in the *Application Information* section of the data sheet. An example and discussion of typical system R_{θJA} values are provided in the *Thermal Information* section. This example provides additional information regarding the power dissipation ratings. This example should be used as a reference to calculate the heat dissipation ratings for a specific application. TI application engineering provides technical support to design heatsinks if needed.

Ordering Information

T _A	PACKAGE	DESCRIPTION
0°C to 70°C	TAS5112ADFD	56-pin small TSSOP
0°C to 70°C	TAS5112ADCA	56-pin small TSSOP

For the most current specification and package information, refer to our Web site at www.ti.com.

Terminal Functions

TERMINAL			FUNCTION ⁽¹⁾	DESCRIPTION
NAME	DFD NO.	DCA NO.		
BST_A	31	54	P	High-side bootstrap supply (BST), external capacitor to OUT_A required
BST_B	42	43	P	High-side bootstrap supply (BST), external capacitor to OUT_B required
BST_C	43	42	P	HS bootstrap supply (BST), external capacitor to OUT_C required
BST_D	54	31	P	HS bootstrap supply (BST), external capacitor to OUT_D required
DGND	23	6	P	Digital I/O reference ground
DREG	16	13	P	Digital supply voltage regulator decoupling pin, capacitor connected to GND
DREG_RTN	12	17	P	Digital supply voltage regulator decoupling return pin
DVDD	25	4	P	I/O reference supply input (3.3 V)
GND	1, 2, 22, 24, 27, 28, 29, 36, 37, 48, 49, 56	1, 2, 5, 7, 27, 28, 29, 36, 37, 48, 49, 56	P	Power ground
GREG	3, 26	3, 26	P	Gate drive voltage regulator decoupling pin, capacitor to REG_GND
GVDD	30, 55	30, 55	P	Voltage supply to on-chip gate drive and digital supply voltage regulators
M1 (TST0)	15	14	I	Mode selection pin
M2	14	15	I	Mode selection pin
M3	13	16	I	Mode selection pin
OTW	4	25	O	Overtemperature warning output, open drain with internal pullup resistor
OUT_A	34, 35	50, 51	O	Output, half-bridge A
OUT_B	38, 39	46, 47	O	Output, half-bridge B
OUT_C	46, 47	38, 39	O	Output, half-bridge C
OUT_D	50, 51	34, 35	O	Output, half-bridge D
PVDD_A	32, 33	52, 53	P	Power supply input for half-bridge A
PVDD_B	40, 41	44, 45	P	Power supply input for half-bridge B
PVDD_C	44, 45	40, 41	P	Power supply input for half-bridge C
PVDD_D	52, 53	32, 33	P	Power supply input for half-bridge D
PWM_AM	20	9	I	Input signal (negative), half-bridge A
PWM_AP	21	8	I	Input signal (positive), half-bridge A
PWM_BM	18	11	I	Input signal (negative), half-bridge B
PWM_BP	17	12	I	Input signal (positive), half-bridge B
PWM_CM	10	19	I	Input signal (negative), half-bridge C
PWM_CP	11	18	I	Input signal (positive), half-bridge C
PWM_DM	8	21	I	Input signal (negative), half-bridge D
PWM_DP	7	22	I	Input signal (positive), half-bridge D
RESET_AB	19	10	I	Reset signal, active low
RESET_CD	9	20	I	Reset signal, active low
SD_AB	6	23	O	Shutdown signal for half-bridges A and B, active-low
SD_CD	5	24	O	Shutdown signal for half-bridges C and D, active-low

⁽¹⁾ I = input, O = Output, P = Power

FUNCTIONAL BLOCK DIAGRAM

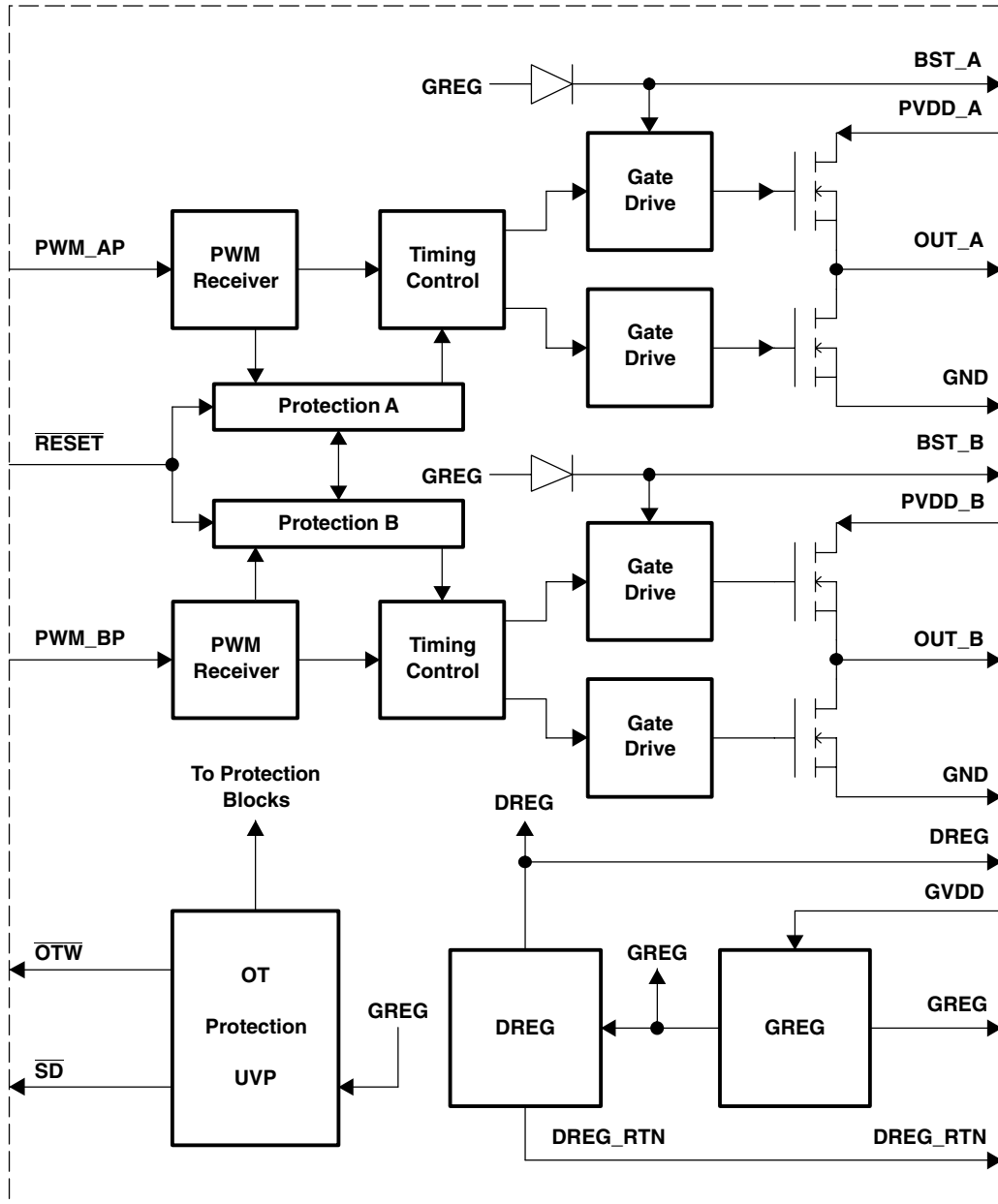

This diagram shows one channel.

TAS5112A

SLES094B - OCTOBER 2003 - REVISED JUNE 2008

RECOMMENDED OPERATING CONDITIONS

			MIN	TYP	MAX	UNIT
DVDD	Digital supply ⁽¹⁾	Relative to DGND	3	3.3	3.6	V
GVDD	Supply for internal gate drive and logic regulators	Relative to GND	16	29.5	30.5	V
PVDD_x	Half-bridge supply	Relative to GND, $R_L = 6\ \Omega$ to $8\ \Omega$	0	29.5	30.5	V
T _J	Junction temperature		0		125	°C

⁽¹⁾ It is recommended for DVDD to be connected to DREG via a 100- Ω resistor.

ELECTRICAL CHARACTERISTICS

PVDD_X = 29.5 V, GVDD = 29.5 V, DVDD connected to DREG via a 100- Ω resistor, $R_L = 6\ \Omega$, $8X\ f_s = 384\ \text{kHz}$, unless otherwise noted

SYMBOL	PARAMETER	TEST CONDITIONS	TYPICAL	OVER TEMPERATURE			UNITS	MIN/TYP/ MAX
			T _A =25°C	T _A =25°C	T _{Case} = 75°C	T _A =40°C TO 85°C		
AC PERFORMANCE, BTL Mode, 1 kHz								
P _o	Output power	$R_L = 8\ \Omega$, THD = 0.2%, AES17 filter, 1 kHz			40		W	Typ
		$R_L = 8\ \Omega$, THD = 10%, AES17 filter, 1 kHz			50		W	Typ
		$R_L = 6\ \Omega$, THD = 0.2%, AES17 filter, 1 kHz			50		W	Typ
		$R_L = 6\ \Omega$, THD = 10%, AES17 filter, 1 kHz			62		W	Typ
THD+N	Total harmonic distortion + noise	P _o = 1 W/channel, $R_L = 6\ \Omega$, AES17 filter			0.03%			Typ
		P _o = 10 W/channel, $R_L = 6\ \Omega$, AES17 filter			0.04%			Typ
		P _o = 50 W/channel, $R_L = 6\ \Omega$, AES17 filter			0.2%			Typ
V _n	Output integrated voltage noise	A-weighted, mute, $R_L = 6\ \Omega$, 20 Hz to 20 kHz, AES17 filter			260		μV	Max
SNR	Signal-to-noise ratio	A-weighted, AES17 filter			96		dB	Typ
DR	Dynamic range	f = 1 kHz, A-weighted, AES17 filter			96		dB	Typ
INTERNAL VOLTAGE REGULATOR								
DREG	Voltage regulator	$I_o = 1\ \text{mA}$, PVDD = 18 V to 30.5 V	3.1				V	Typ
GREG	Voltage regulator	$I_o = 1.2\ \text{mA}$, PVDD = 18 V to 30.5 V	13.4				V	Typ
IGVDD	GVDD supply current, operating	$f_s = 384\ \text{kHz}$, no load, 50% duty cycle		24 ⁽¹⁾			mA	Max
IDVDD	DVDD supply current, operating	$f_s = 384\ \text{kHz}$, no load	1	5			mA	Max
OUTPUT STAGE MOSFETs								
R _{DSon,LS}	Forward on-resistance, low side	T _J = 25°C	155				m Ω	Typ
R _{DSon,HS}	Forward on-resistance, high side	T _J = 25°C	155				m Ω	Typ

⁽¹⁾ Measured with TI standard manufacturing hardware configuration

ELECTRICAL CHARACTERISTICS

 PVDD_x = 29.5 V, GVDD = 29.5 V, DVDD connected to DREG via a 100-Ω resistor, R_L = 6 Ω, 8X f_s = 384 kHz, unless otherwise noted

SYMBOL	PARAMETER	TEST CONDITIONS	TYPICAL	OVER TEMPERATURE				
			T _A =25°C	T _A =25°C	T _{Case} =75°C	T _A =40°C TO 85°C	UNITS	MIN/TYP/MAX
INPUT/OUTPUT PROTECTION								
V _{uvp,G}	Undervoltage protection limit, GVDD	Set the DUT in normal operation mode with all the protections enabled. Sweep GVDD up and down. Monitor \overline{SD} output. Record the GREG reading when \overline{SD} is triggered.	7.4	6.9			V	Min
				7.9			V	Max
OTW	Overtemperature warning, junction temperature		125				°C	Typ
OTE	Overtemperature error, junction temperature		150				°C	Typ
OC	Overcurrent protection	See Note 1.	6.7				A	Typ
STATIC DIGITAL SPECIFICATION								
	PWM_AP, PWM_BP, M1, M2, M3, \overline{SD} , \overline{OTW}							
V _{IH}	High-level input voltage			2			V	Min
				DVDD			V	Max
V _{IL}	Low-level input voltage			0.8			V	Max
Leakage	Input leakage current			-10			μA	Min
				10			μA	Max
OTW/SHUTDOWN (SD)								
	Internally pull up R from $\overline{OTW/SD}$ to DVDD		30	22.5			kΩ	Min
V _{OL}	Low-level output voltage	I _O = 4 mA		0.4			V	Max

(1) To optimize device performance and prevent overcurrent (OC) protection tripping, the demodulation filter must be designed with special care. See *Demodulation Filter Design* in the *Application Information* section of the data sheet and consider the recommended inductors and capacitors for optimal performance. It is also important to consider PCB design and layout for optimum performance of the TAS5112A. It is recommended to follow the TAS5112F2EVM (S/N 112) design and layout guidelines for best performance.

TAS5112A

SLES094B - OCTOBER 2003 - REVISED JUNE 2008

SYSTEM CONFIGURATION USED FOR CHARACTERIZATION

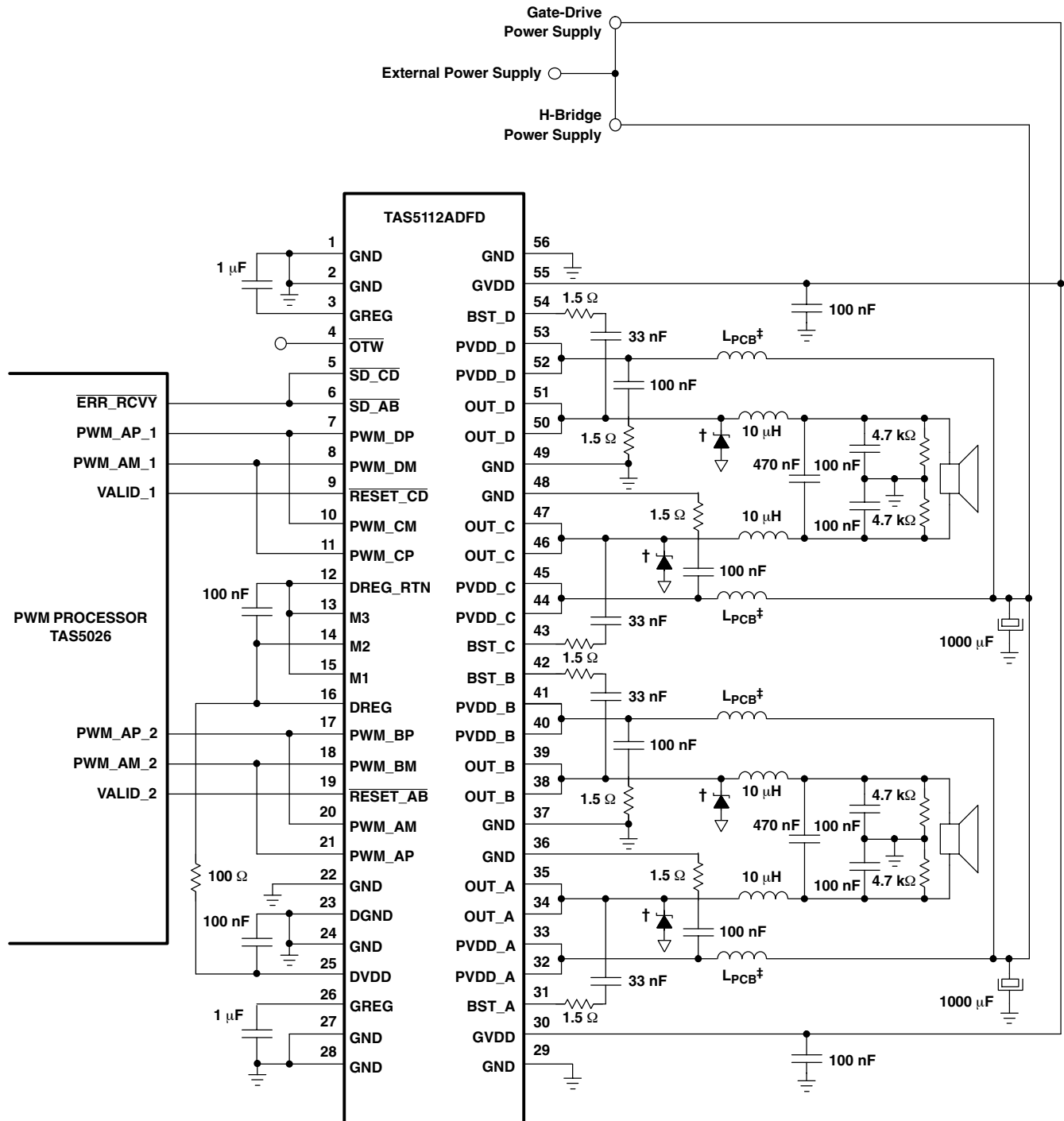

† Voltage suppressor diodes: 1SMA33CAT

‡ L_{PCB} : Track in the PCB (1,0 mm wide and 50 mm long)

TYPICAL CHARACTERISTICS AND SYSTEM PERFORMANCE
OF TAS5112ADFD EVM WITH TAS5026 PWM PROCESSOR

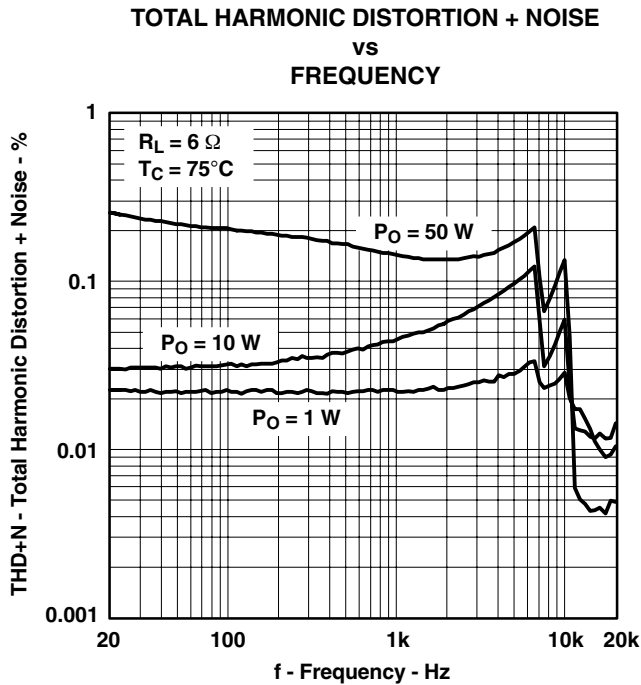

Figure 1

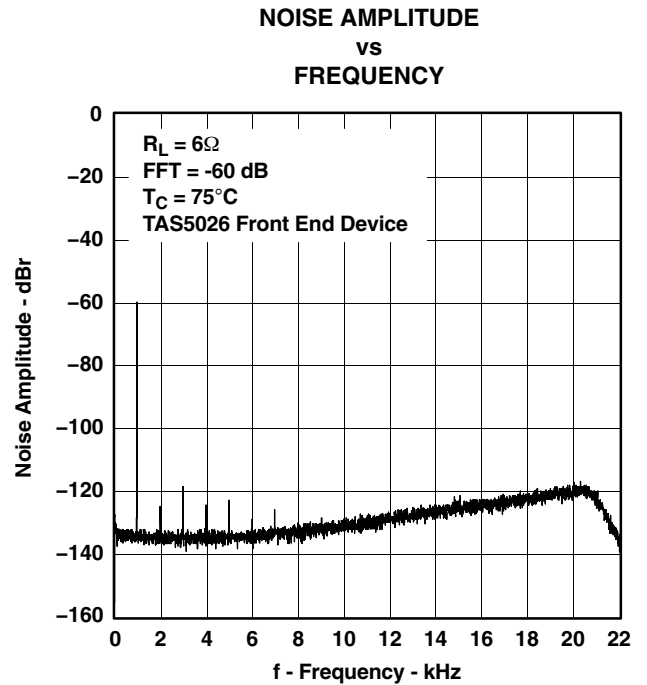

Figure 2

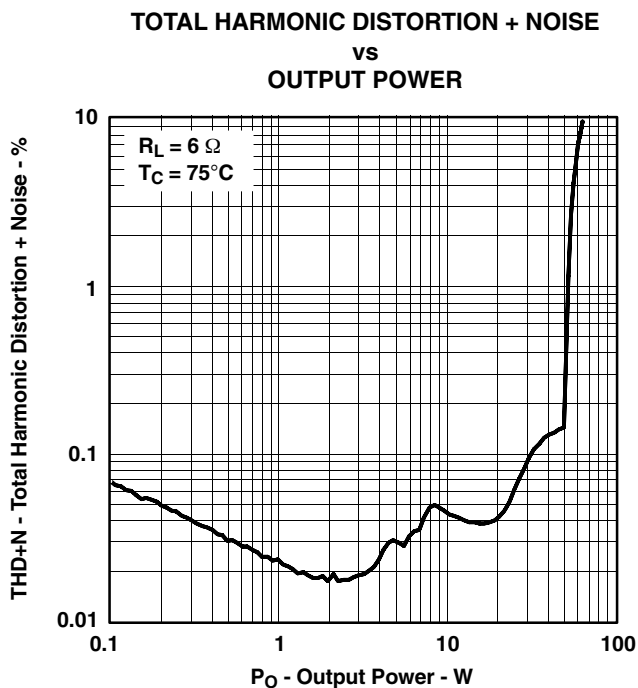

Figure 3

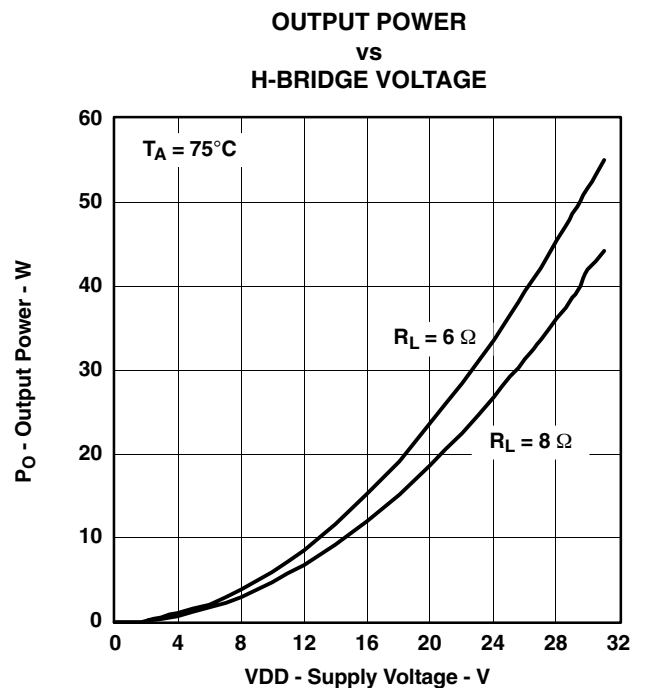

Figure 4

TAS5112A

SLES094B - OCTOBER 2003 - REVISED JUNE 2008

**SYSTEM OUTPUT STAGE EFFICIENCY
vs
OUTPUT POWER**

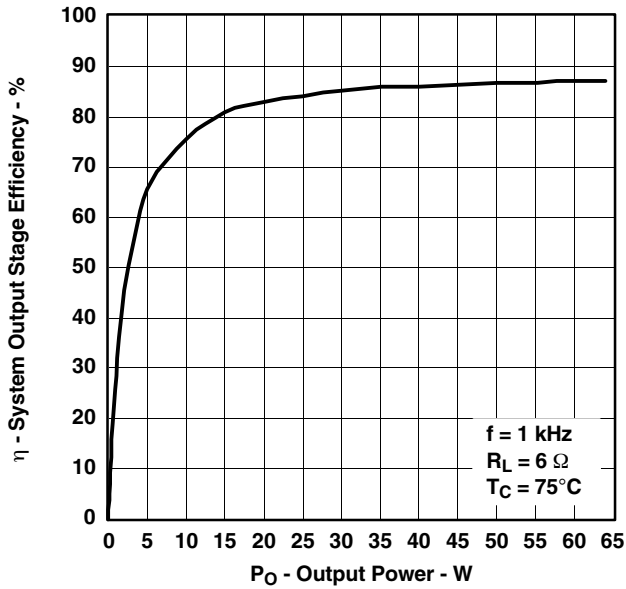

Figure 5

**POWER LOSS
vs
OUTPUT POWER**

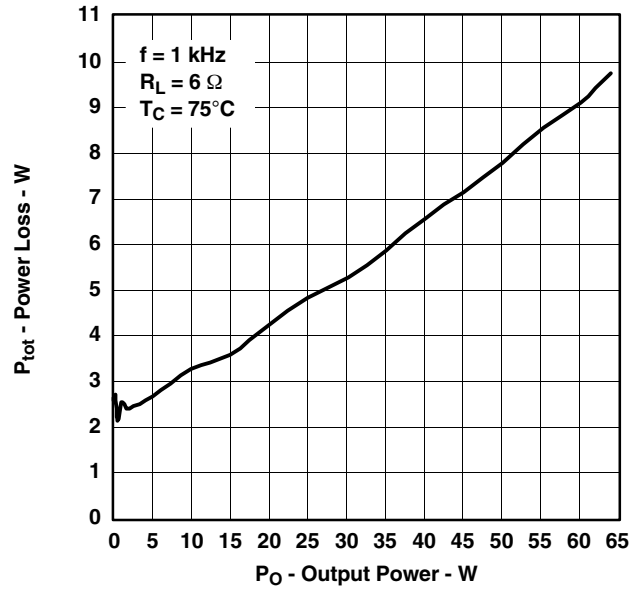

Figure 6

**OUTPUT POWER
vs
CASE TEMPERATURE**

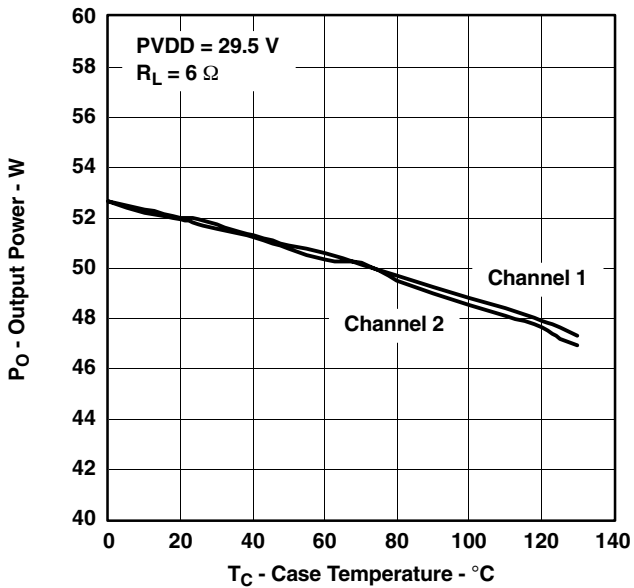

Figure 7

**AMPLITUDE
vs
FREQUENCY**

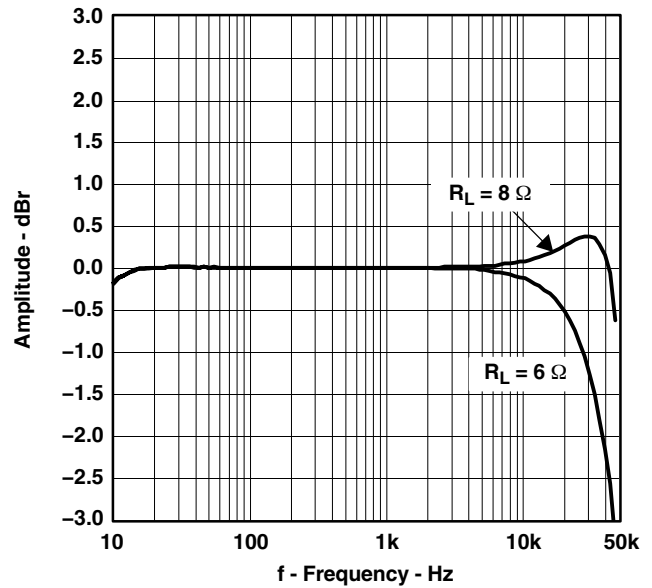

Figure 8

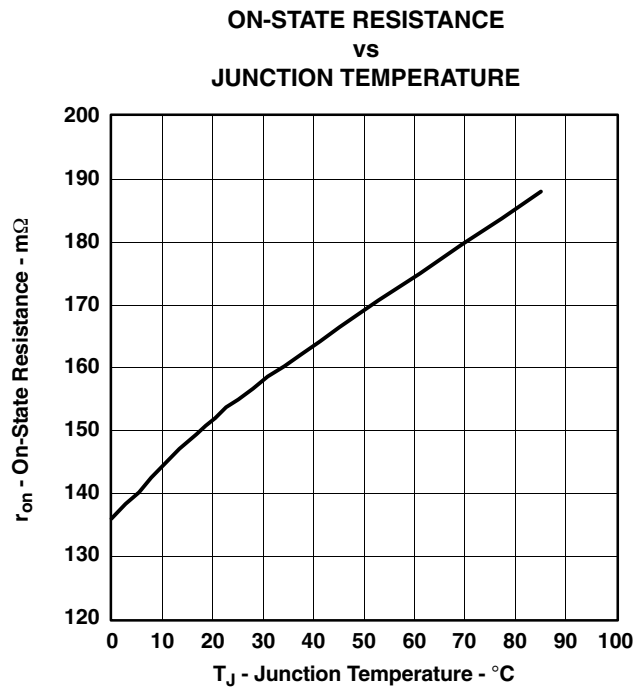

Figure 9

TAS5112A

SLES094B - OCTOBER 2003 - REVISED JUNE 2008

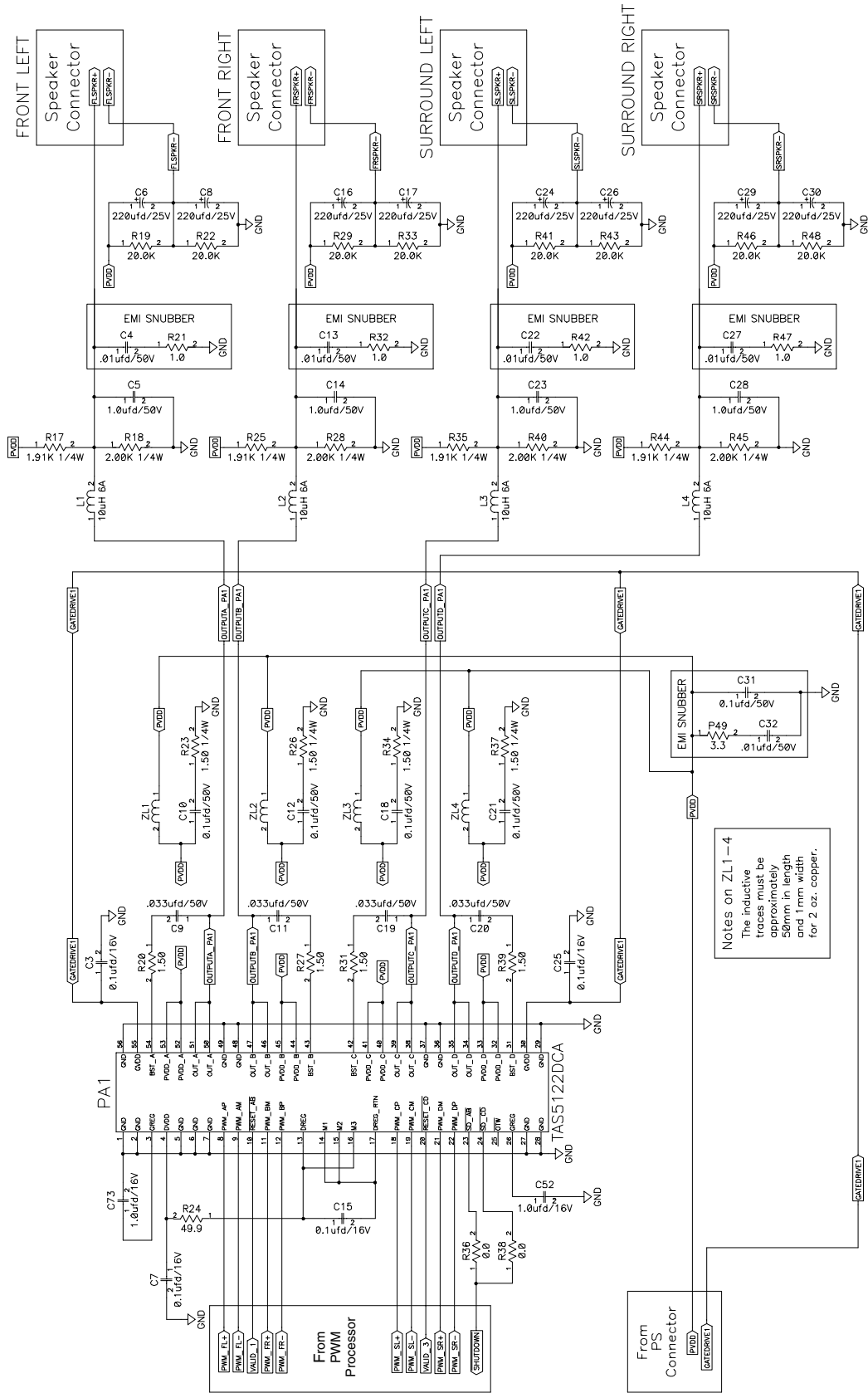

Figure 10. Typical Single-Ended Design With TAS5112A DCA

THEORY OF OPERATION

POWER SUPPLIES

The power device only requires two supply voltages, GVDD and PVDD_X.

GVDD is the gate drive supply for the device, regulated internally down to approximately 12 V, and decoupled with regards to board GND on the GREG pins through an external capacitor. GREG powers both the low side and high side via a bootstrap step-up conversion. The bootstrap supply is charged after the first low-side turn-on pulse. Internal digital core voltage DREG is also derived from GVDD and regulated down by internal circuitry to 3.3 V.

The gate-driver regulator can be bypassed for reducing idle loss in the device by shorting GREG to GVDD and directly feeding in 12.0 V. This can be useful in an application where thermal conduction of heat from the device is difficult.

PVDD_X is the H-bridge power supply pin. Two power pins exists for each half-bridge to handle the current density. It is important that the circuitry recommendations concerning the PVDD_X pins are followed carefully both topology- and layout-wise. For topology recommendations, see the *System Configuration Used for Characterization* section. Following these recommendations is important for parameters like EMI, reliability, and performance.

POWERING UP

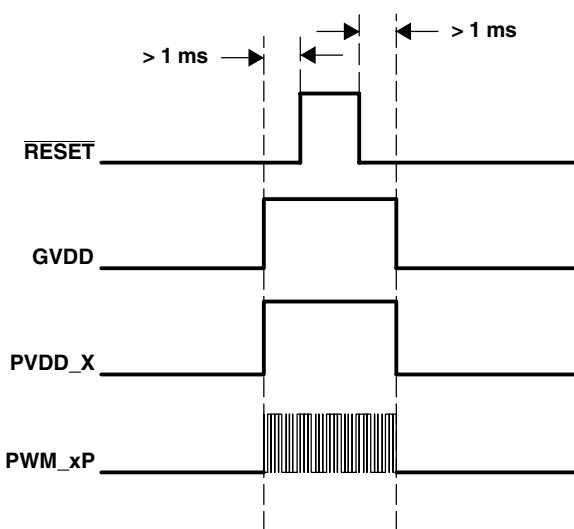

NOTE: PVDD should not be powered up before GVDD.

During power up when $\overline{\text{RESET}}$ is asserted LOW, all MOSFETs are turned off and the two internal half-bridges are in the high-impedance state (Hi-Z). The bootstrap capacitors supplying high-side gate drive are not charged at this point. To comply with the click and pop scheme and use of non-TI modulators, it is recommended to use a

4.7-k Ω pulldown resistor on each PWM output node to ground. This precharges the bootstrap supply capacitors and discharges the output filter capacitor.

After GVDD has been applied, it takes approximately 800 μs to fully charge the BST capacitor. Within this time, $\overline{\text{RESET}}$ must be kept low. After approximately 1 ms, the back-end bootstrap capacitor is charged.

$\overline{\text{RESET}}$ can now be released if the modulator is powered up and streaming valid PWM signals to the back-end PWM_xP. Valid means a switching PWM signal which complies with the frequency and duty cycle ranges stated in the *Recommended Operating Conditions*.

A constant HIGH dc level on the PWM_xP is not permitted, because it would force the high-side MOSFET ON until it eventually ran out of BST capacitor energy and might damage the device.

An unknown state of the PWM output signals from the modulator is illegal and should be avoided, which in practice means that the PWM processor must be powered up and initialized before $\overline{\text{RESET}}$ is de-asserted HIGH to the back end.

POWERING DOWN

For power down of the back end, an opposite approach is necessary. The $\overline{\text{RESET}}$ must be asserted LOW before the valid PWM signal is removed.

When PWM processors are used with TI PurePath Digital amplifiers, the correct timing control of $\overline{\text{RESET}}$ and PWM_xP is performed by the modulator.

PRECAUTION

The TAS5112A must always start up in the high-impedance (Hi-Z) state. In this state, the bootstrap (BST) capacitor is precharged by a resistor on each PWM output node to ground. See the system configuration. This ensures that the back end is ready for receiving PWM pulses, indicating either HIGH- or LOW-side turnon after $\overline{\text{RESET}}$ is de-asserted to the back end.

With the following pulldown resistor and BST capacitor size, the charge time is:

$$C = 33 \text{ nF}, R = 4.7 \text{ k}\Omega$$

$$R \times C \times 5 = 775.5 \mu\text{s}$$

After GVDD has been applied, it takes approximately 800 μs to fully charge the BST capacitor. During this time, $\overline{\text{RESET}}$ must be kept low. After approximately 1 ms the back end BST is charged and ready. $\overline{\text{RESET}}$ can now be released if the PWM modulator is ready and is streaming valid PWM signals to the back end. Valid PWM signals are switching PWM signals with a frequency between 350–400 kHz. A constant HIGH level on the PWM+ would force the high-side MOSFET ON until it eventually ran out of BST capacitor energy. Putting the device in this condition should be avoided.

TAS5112A

SLES094B - OCTOBER 2003 - REVISED JUNE 2008

In practice this means that the DVDD-to-PWM processor (front-end) should be stable and initialization should be completed before $\overline{\text{RESET}}$ is de-asserted to the back end.

CONTROL I/O

Shutdown Pin: $\overline{\text{SD}}$

The $\overline{\text{SD}}$ pin functions as an output pin and is intended for protection-mode signaling to, for example, a controller or other front-end device. The pin is open-drain with an internal pullup resistor to DVDD.

The logic output is, as shown in the following table, a combination of the device state and $\overline{\text{RESET}}$ input:

SD	RESET	DESCRIPTION
0	0	Reserved
0	1	Device in protection mode, i.e., UV and/or OC and/or OT error
1 ⁽²⁾	0	Device set high-impedance (Hi-Z), $\overline{\text{SD}}$ forced high
1	1	Normal operation

⁽²⁾ $\overline{\text{SD}}$ is pulled high when $\overline{\text{RESET}}$ is asserted low independent of chip state (i.e., protection mode). This is desirable to maintain compatibility with some TI PWM front ends.

Temperature Warning Pin: $\overline{\text{OTW}}$

The $\overline{\text{OTW}}$ pin gives a temperature warning signal when temperature exceeds the set limit. The pin is of the open-drain type with an internal pullup resistor to DVDD.

$\overline{\text{OTW}}$	DESCRIPTION
0	Junction temperature higher than 125°C
1	Junction temperature lower than 125°C

Overall Reporting

The $\overline{\text{SD}}$ pin, together with the $\overline{\text{OTW}}$ pin, gives chip state information as described in Table 1.

Table 1. Error Signal Decoding

$\overline{\text{OTW}}$	SD	DESCRIPTION
0	0	Overtemperature error (OTE)
0	1	Overtemperature warning (OTW)
1	0	Overcurrent (OC) or undervoltage (UV) error
1	1	Normal operation, no errors/warnings

Chip Protection

The TAS5112A protection function is implemented in a closed loop with, for example, a system controller and TI PWM processor. The TAS5112A contains three individual systems protecting the device against error conditions. All of the error events covered result in the output stage being set in a high-impedance state (Hi-Z) for maximum protection of the device and connected equipment.

The device can be recovered by toggling $\overline{\text{RESET}}$ low and then high, after all errors are cleared.

Overcurrent (OC) Protection

The device has individual forward current protection on both high-side and low-side power stage FETs. The OC protection works only with the demodulation filter present at the output. See *Demodulation Filter Design* in the *Application Information* section of the data sheet for design constraints.

Overtemperature (OT) Protection

A dual temperature protection system asserts a warning signal when the device junction temperature exceeds 125°C. The OT protection circuit is shared by all half-bridges.

Undervoltage (UV) Protection

Undervoltage lockout occurs when GVDD is insufficient for proper device operation. The UV protection system protects the device under power-up and power-down situations. The UV protection circuits are shared by all half-bridges.

Reset Function

The reset has two functions:

- Reset is used for re-enabling operation after a latching error event.
- Reset is used for disabling output stage switching (mute function).

The error latch is cleared on the falling edge of reset and normal operation is resumed when reset goes high.

PROTECTION MODE

Autorecovery (AR) After Errors (PMODE0)

In autorecovery mode (PMODE0) the TAS5112A is self-supported in handling of error situations. All protection systems are active, setting the output stage in the high-impedance state to protect the output stage and connected equipment. However, after a short time period the device autorecovers, i.e., operation is automatically resumed provided that the system is fully operational.

The autorecovery timing is set by counting PWM input cycles, i.e., the timing is relative to the switching frequency.

The AR system is common to both half-bridges.

Timing and Function

The function of the autorecovery circuit is as follows:

1. An error event occurs and sets the protection latch (output stage goes Hi-Z).
2. The counter is started.
3. After $n/2$ cycles, the protection latch is cleared but the output stage remains Hi-Z (identical to pulling $\overline{\text{RESET}}$ low).
4. After n cycles, operation is resumed (identical to pulling $\overline{\text{RESET}}$ high) ($n = 512$).

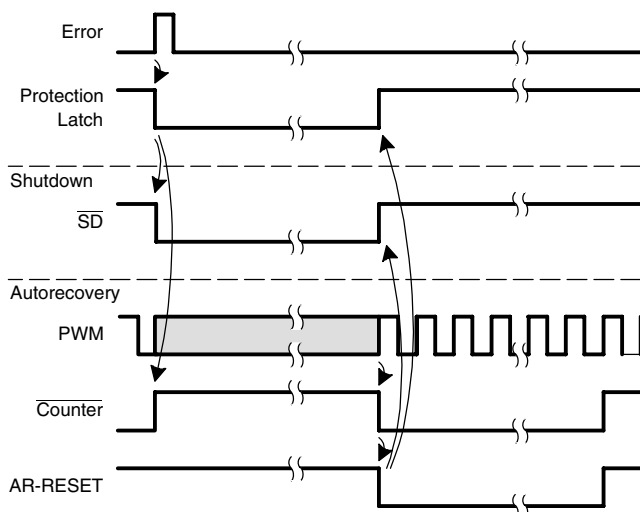

Figure 11. Autorecovery Function

Latching Shutdown on All Errors (PMODE1)

In latching shutdown mode, all error situations result in a power down (output stage Hi-Z). Re-enabling can be done by toggling the $\overline{\text{RESET}}$ pin.

All Protection Systems Disabled (PMODE2)

In PMODE2, all protection systems are disabled. This mode is purely intended for testing and characterization purposes and thus not recommended for normal device operation.

MODE Pins Selection

The protection mode is selected by shorting M1/M2 to DREG or DGND according to Table 2.

Table 2. Protection Mode Selection

M1	M2	PROTECTION MODE
0	0	Autorecovery after errors (PMODE 0)
0	1	Latching shutdown on all errors (PMODE 1)
1	0	All protection systems disabled (PMODE 2)
1	1	Reserved

The output configuration mode is selected by shorting the M3 pin to DREG or DGND according to Table 3.

Table 3. Output Mode Selection

M3	OUTPUT MODE
0	Bridge-tied load output stage (BTL)
1	Reserved

APPLICATION INFORMATION

DEMODULATION FILTER DESIGN AND SPIKE CONSIDERATIONS

The output square wave is susceptible to overshoots (voltage spikes). The spike characteristics depend on many elements, including silicon design and application design and layout. The device should be able to handle narrow spike pulses, less than 65 ns, up to 65 volts peak. For more detailed information, see TI application report SLEA025.

The PurePath Digital amplifier outputs are driven by heavy-duty DMOS transistors in an H-bridge configuration. These transistors are either off or fully on, which reduces the DMOS transistor on-state resistance, R_{DSon} , and the power dissipated in the device, thereby increasing efficiency.

The result is a square-wave output signal with a duty cycle that is proportional to the amplitude of the audio signal. It is recommended that a second-order LC filter be used to recover the audio signal. For this application, EMI is considered important; therefore, the selected filter is the full-output type shown in Figure 12.

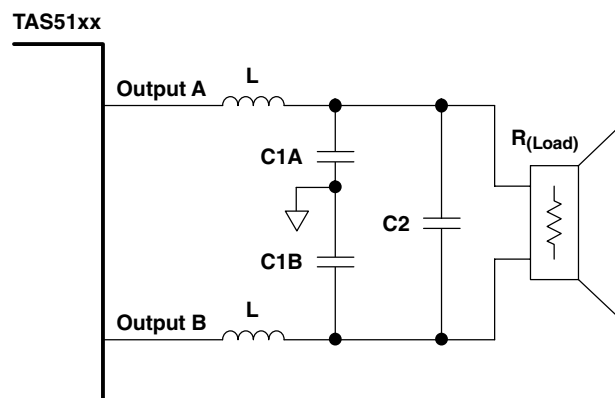

Figure 12. Demodulation Filter

The main purpose of the output filter is to attenuate the high-frequency switching component of the PurePath Digital amplifier while preserving the signals in the audio band.

Design of the demodulation filter affects the performance of the power amplifier significantly. As a result, to ensure proper operation of the overcurrent (OC) protection circuit and meet the device THD+N specifications, the selection of the inductors used in the output filter must be considered according to the following. The rule is that the inductance

TAS5112A

SLES094B - OCTOBER 2003 - REVISED JUNE 2008

should remain stable within the range of peak current seen at maximum output power and deliver at least 5 μH of inductance at 15 A.

If this rule is observed, the TAS5112A does not have distortion issues due to the output inductors, and overcurrent conditions do not occur due to inductor saturation in the output filter.

Another parameter to be considered is the idle current loss in the inductor. This can be measured or specified as inductor dissipation (D). The target specification for dissipation is less than 0.05.

In general, 10- μH inductors suffice for most applications. The frequency response of the amplifier is slightly altered by the change in output load resistance; however, unless tight control of frequency response is necessary (better than 0.5 dB), it is not necessary to deviate from 10 μH .

The graph in Figure 13 displays the inductance vs current characteristics of two inductors that are recommended for use with the TAS5112A.

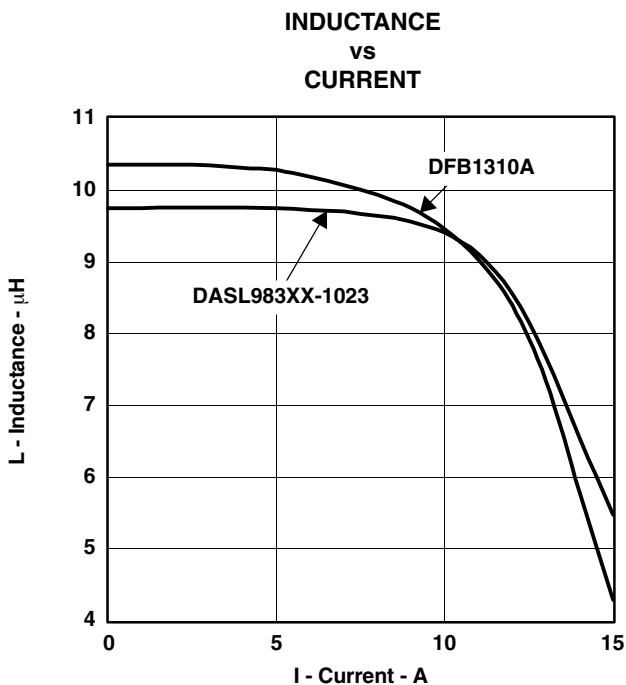

Figure 13. Inductance Saturation

The selection of the capacitor that is placed across the output of each inductor (C2 in Figure 12) is simple. To complete the output filter, use a 0.47- μF capacitor with a voltage rating at least twice the voltage applied to the output stage (PVDD).

This capacitor should be a good quality polyester dielectric such as a Wima MKS2-047ufd/100/10 or equivalent.

In order to minimize the EMI effect of unbalanced ripple loss in the inductors, 0.1- μF 50-V SMD capacitors (X7R or better) (C1A and C1B in Figure 12) should be added from the output of each inductor to ground.

THERMAL INFORMATION

The thermally augmented package provided with the TAS5112A is designed to be interfaced directly to heatsinks using a thermal interface compound (for example, Wakefield Engineering type 126 thermal grease.) The heatsink then absorbs heat from the ICs and couples it to the local air. If the heatsink is carefully designed, this process can reach equilibrium and heat can be continually removed from the ICs. Because of the efficiency of the TAS5112A, heatsinks can be smaller than those required for linear amplifiers of equivalent performance.

$R_{\theta JA}$ is a system thermal resistance from junction to ambient air. As such, it is a system parameter with roughly the following components:

- $R_{\theta JC}$ (the thermal resistance from junction to case, or in this case the metal pad)
- Thermal grease thermal resistance
- Heatsink thermal resistance

$R_{\theta JC}$ has been provided in the *General Information* section.

The thermal grease thermal resistance can be calculated from the exposed pad area and the thermal grease manufacturer's area thermal resistance (expressed in $^{\circ}\text{C}\text{-in}^2/\text{W}$). The area thermal resistance of the example thermal grease with a 0.002-inch thick layer is about 0.1 $^{\circ}\text{C}\text{-in}^2/\text{W}$. The approximate exposed pad area is as follows:

56-pin HTSSOP 0.045 in^2

Dividing the example thermal grease area resistance by the surface area gives the actual resistance through the thermal grease for both ICs inside the package:

56-pin HTSSOP 2.27 $^{\circ}\text{C}/\text{W}$

The thermal resistance of thermal pads is generally considerably higher than a thin thermal grease layer. Thermal tape has an even higher thermal resistance. Neither pads nor tape should be used with either of these two packages. A thin layer of thermal grease with careful clamping of the heatsink is recommended. It may be difficult to achieve a layer 0.001-inch thick or less, so the modeling below is done with a 0.002-inch thick layer, which may be more representative of production thermal grease thickness.

Heatsink thermal resistance is generally predicted by the heatsink vendor, modeled using a continuous flow dynamics (CFD) model, or measured.

Thus, for a single monaural IC, the system $R_{\theta JA} = R_{\theta JC} +$ thermal grease resistance + heatsink resistance.

Table 4, Table 5, and Table 6 indicate modeled parameters for one or two TAS5112A ICs on a single heatsink. The final junction temperature is set at 110°C in all cases. It is assumed that the thermal grease is 0.002 inch thick and that it is similar in performance to Wakefield Type 126 thermal grease. It is important that the thermal grease layer is ≤ 0.002 inches thick and that thermal pads or tape are not used in the pad-to-heatsink interface due to the high power density that results in these extreme power cases.

Table 4. Case 1 (2 × 50 W Unclipped Into 6 Ω, Both Channels in Same IC) (1)

	56-Pin HTSSOP
Ambient temperature	25°C
Power to load (per channel)	50 W (unclipped)
Power dissipation	4.5 W
Delta T inside package	10.2°C, note 2 × channel dissipation
Delta T through thermal grease	37.1°C, note 2 × channel dissipation
Required heatsink thermal resistance	4.2°C/W
Junction temperature	110°C
System $R_{\theta JA}$	19°C/W
$R_{\theta JA}$ * power dissipation	85°C
Junction temperature	85°C + 25°C = 110°C

(1) This case represents a stereo system with only one package. See Case 2 and Case 2A if doing a full-power, 2-channel test in a multichannel system.

Table 5. Case 2 (2 × 50 W Unclipped Into 6 Ω, Channels in Separate Packages) (1)

	56-Pin HTSSOP
Ambient temperature	25°C
Power to load (per channel)	50 W (unclipped)
Power dissipation	4.5 W
Delta T inside package	5.1°C
Delta T through thermal grease	18.6°C
Required heatsink thermal resistance	6.9°C/W
Junction temperature	110°C
System $R_{\theta JA}$	19°C/W
$R_{\theta JA}$ * power dissipation	85°C
Junction temperature	85°C + 25°C = 110°C

(1) In this case, the power is separated into two packages. Note that this allows a considerably smaller heatsink because twice as much area is available for heat transfer through the thermal grease. For this reason, separating the stereo channels into two ICs is recommended in full-power stereo tests made on multichannel systems.

Table 6. Case 2A (2 × 60 W Into 6 Ω, Channels in Separate IC Packages) (1)

	56-Pin HTSSOP
Ambient temperature	25°C
Power to load (per channel)	60 W (10% THD)
Power dissipation per channel	5.4 W
Delta T inside package	6.1°C, note 2 × channel dissipation
Delta T through thermal grease	22.3°C, note 2 × channel dissipation
Required heatsink thermal resistance	5.3°C/W
Junction temperature	110°C
System $R_{\theta JA}$	15.9°C/W
$R_{\theta JA}$ * power dissipation	85°C
Junction temperature	85°C + 25°C = 110°C

(1) In this case, the power is also separated into two packages, but overdriving causes clipping to 10% THD. In this case, the high power requires extreme care in attachment of the heatsink to ensure that the thermal grease layer is ≤ 0.002 inches thick. Note that this power level should not be attempted with both channels in a single IC because of the high power density through the thermal grease layer.

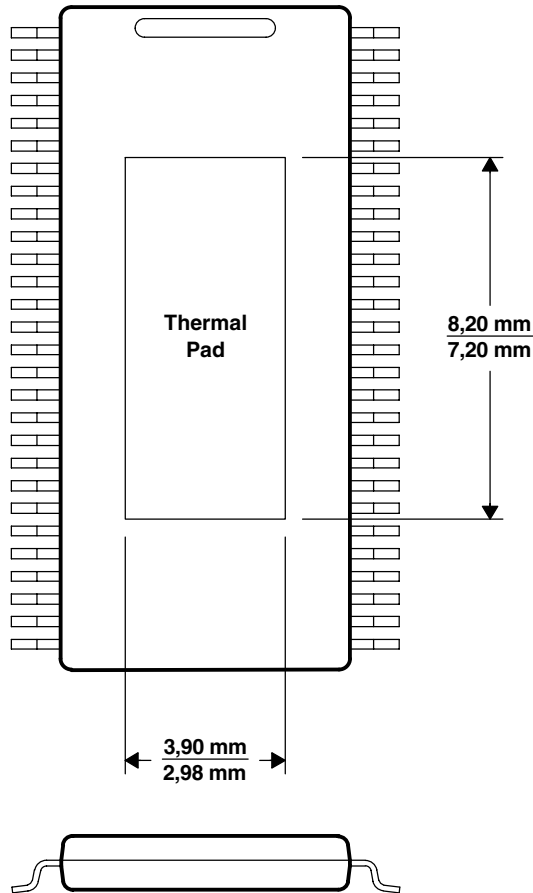

DCA THERMAL INFORMATION

The thermally enhanced DCA package is based on the 56-pin HTSSOP, but includes a thermal pad (see Figure 14) to provide an effective thermal contact between the IC and the PCB.

The PowerPAD™ package (thermally enhanced HTSSOP) combines fine-pitch, surface-mount technology with thermal performance comparable to much larger power packages.

The PowerPAD package is designed to optimize the heat transfer to the PWB. Because of the small size and limited mass of an HTSSOP package, thermal enhancement is achieved by improving the thermal conduction paths that remove heat from the component. The thermal pad is formed using a patented lead-frame design and manufacturing technique to provide a direct connection to the heat-generating IC. When this pad is soldered or otherwise thermally coupled to an external heat dissipater, high power dissipation in the ultrathin, fine-pitch, surface-mount package can be reliably achieved.

Thermal Methodology for the DCA 56-Pin, 2×15-W, 8-Ω Package

The thermal design for the DCA part (e.g., thermal pad soldered to the board) should be similar to the design in the following figures. The cooling approach is to conduct the dissipated heat into the via pads on the board, through the vias in the board, and into a heatsink (aluminum bar) (if necessary).

Figure 14 shows a recommended land pattern on the PCB.

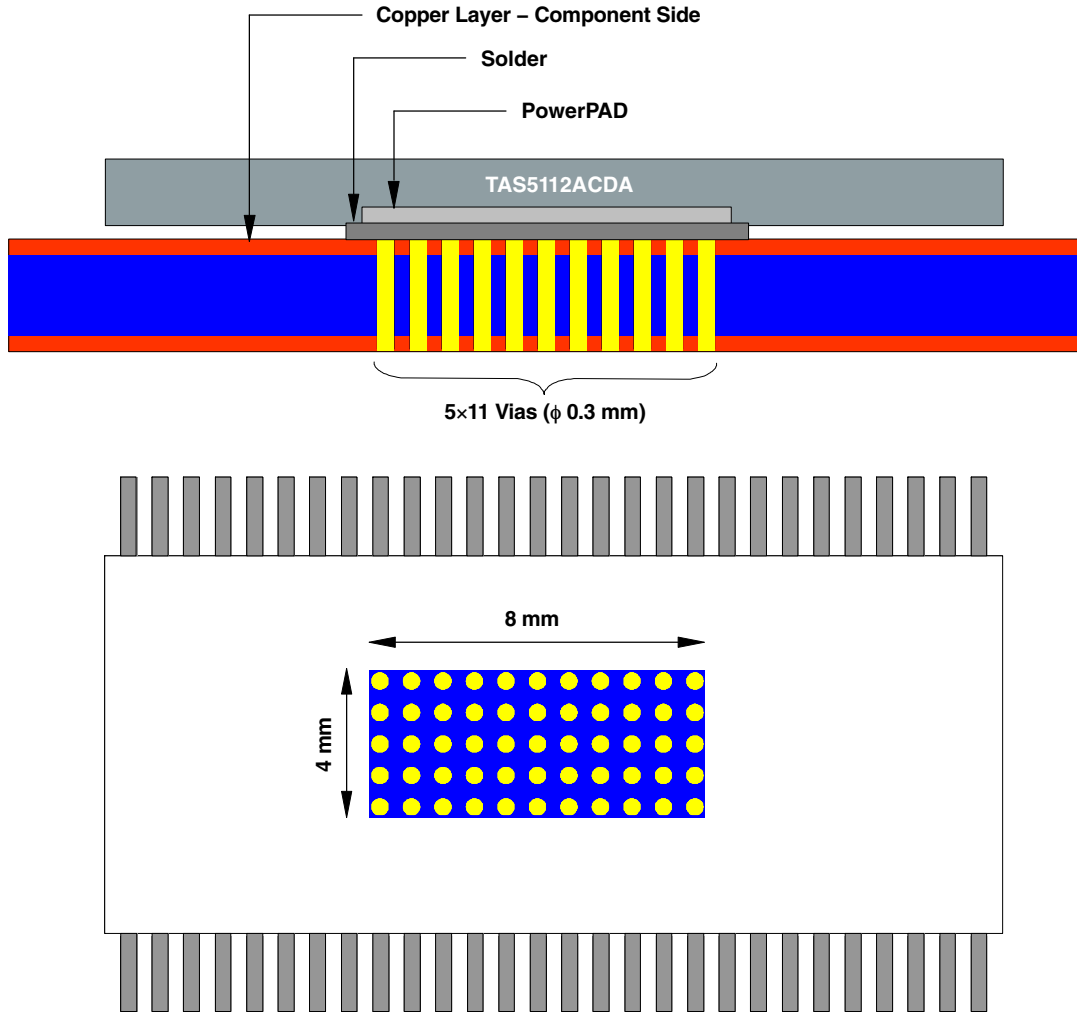

Figure 14. Recommended Land Pattern

The lower via pad area, slightly larger than the IC pad itself, is exposed with a window in the solder resist on the bottom surface of the board. It is not coated with solder during the board construction to maintain a flat surface. In production, this can be accomplished with a peelable solder mask.

An aluminum bar is used to keep the through-hole leads

from shorting to the chassis. The thermal compound shown has a pad-to-aluminum bar thermal resistance of about 3.2°C/W.

The chassis provides the only heatsink to air and is chosen as representative of a typical production cooling approach.

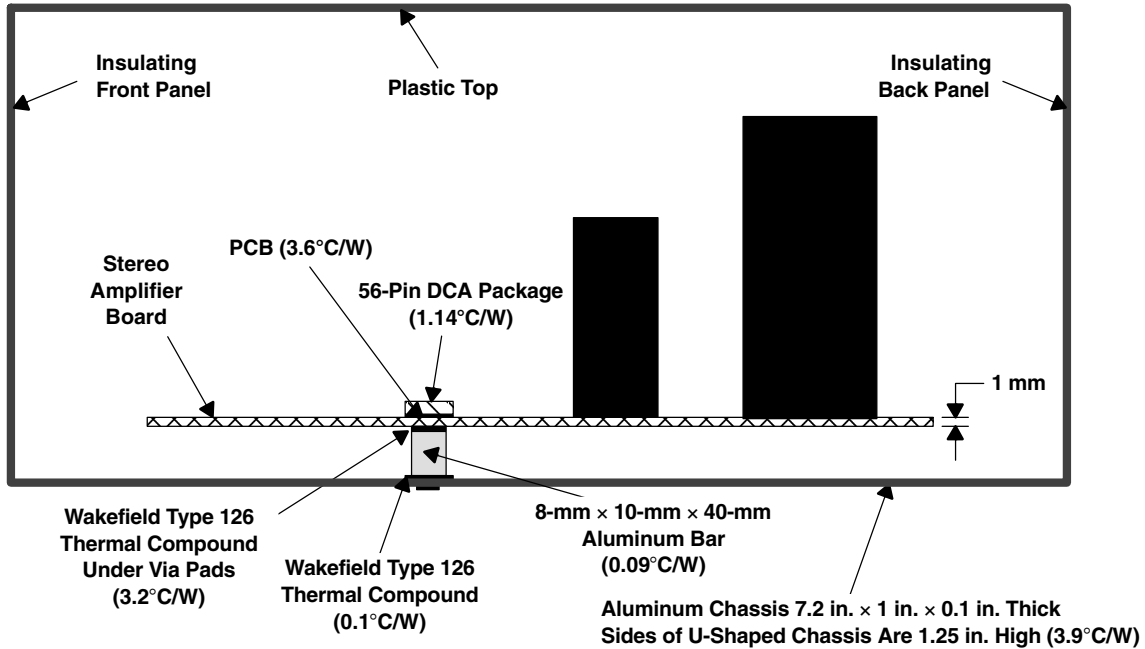

Figure 15. 56-Pin DCA Package Cross-Sectional View (Side)

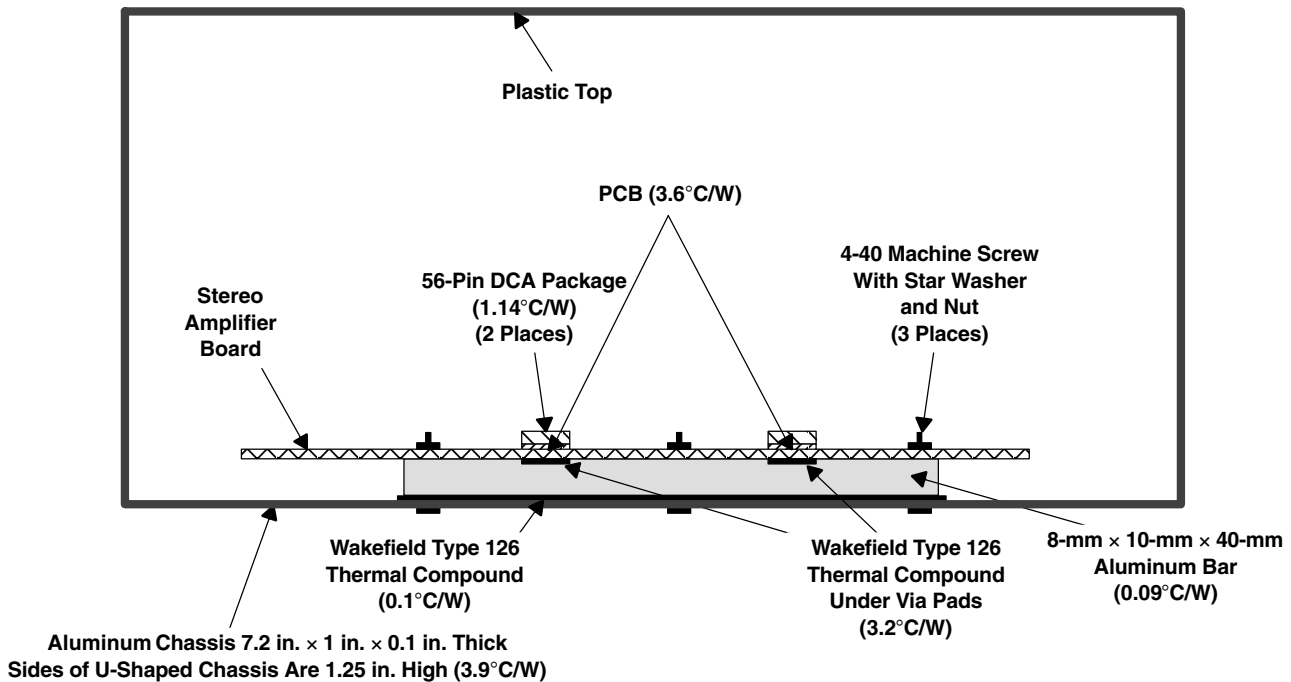

Figure 16. Spatial Separation With Multiple Packages

The land pattern recommendation shown in Figure 14 is for optimal performance with aluminum bar thermal resistance of 0.09°C/W . The following table shows the

decrease in thermal resistance through the PCB with a corresponding increase in the land pattern size. Use the table for thermal design tradeoffs.

LAND PATTERN	PCB THERMAL RESISTANCE
7 × 13 vias (5 × 10 mm)	2.2°C/W
5 × 11 vias (4 × 8 mm)	3.6°C/W

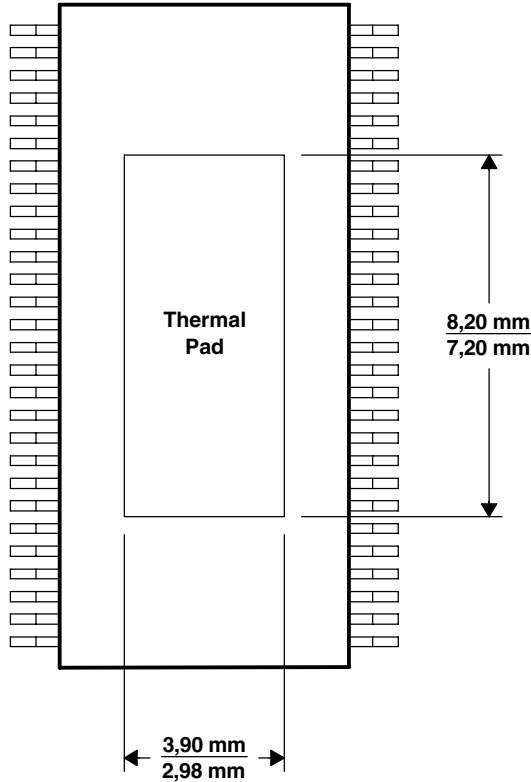

Figure 17. Thermal Pad Dimensions for DCA Package

CLICK AND POP REDUCTION

TI modulators feature a pop and click reduction system that controls the timing when switching starts and stops.

Going from nonswitching to switching operation causes a spectral energy burst to occur within the audio bandwidth, which is heard in the speaker as an audible click, for instance, after having asserted $\overline{\text{RESET}}$ LH during a system start-up.

To make this system work properly, the following design rules must be followed when using the TAS5112A back end:

- The relative timing between the PWM_AP/M_x signals and their corresponding VALID_x signal should not be skewed by inserting delays, because this increases the audible amplitude level of the click.
- The output stage must start switching from a fully discharged output filter capacitor. Because the output stage prior to operation is in the high-impedance state, this is done by having a passive pulldown resistor on each speaker output to GND (see *System Configuration Used for Characterization*).

Other things that can affect the audible click level:

- The spectrum of the click seems to follow the speaker impedance vs. frequency curve—the higher the impedance, the higher the click energy.
- Crossover filters used between woofer and tweeter in a speaker can have high impedance in the audio band, which should be avoided if possible.

Another way to look at it is that the speaker impulse response is a major contributor to how the click energy is shaped in the audio band and how audible the click will be.

The following mode transitions feature click and pop reduction.

STATE		CLICK AND POP REDUCED
Normal ⁽¹⁾	→ Mute	Yes
Mute	→ Normal ⁽¹⁾	Yes
Normal ⁽¹⁾	→ Error recovery (ERRCVY)	Yes
Error recovery	→ Normal ⁽¹⁾	Yes
Normal ⁽¹⁾	→ Hard reset	No
Hard reset	→ Normal ⁽¹⁾	Yes

⁽¹⁾ Normal = switching

REFERENCES

1. *TAS5000 Digital Audio PWM Processor* data manual—TI (SLAS270)
2. *True Digital Audio Amplifier TAS5001 Digital Audio PWM Processor* data sheet—TI (SLES009)
3. *True Digital Audio Amplifier TAS5010 Digital Audio PWM Processor* data sheet—TI (SLAS328)
4. *True Digital Audio Amplifier TAS5012 Digital Audio PWM Processor* data sheet—TI (SLES006)
5. *TAS5026 Six-Channel Digital Audio PWM Processor* data manual—TI (SLES041)
6. *TAS5036A Six-Channel Digital Audio PWM Processor* data manual—TI (SLES061)
7. *TAS3103 Digital Audio Processor With 3D Effects* data manual—TI (SLES038)
8. *Digital Audio Measurements* application report—TI (SLAA114)
9. *PowerPAD™ Thermally Enhanced Package* technical brief—TI (SLMA002)
10. *System Design Considerations for True Digital Audio Power Amplifiers* application report—TI (SLAA117)

PACKAGING INFORMATION

Orderable Device	Status (1)	Package Type	Package Drawing	Pins	Package Qty	Eco Plan (2)	Lead finish/ Ball material (6)	MSL Peak Temp (3)	Op Temp (°C)	Device Marking (4/5)	Samples
TAS5112ADCA	ACTIVE	HTSSOP	DCA	56	35	RoHS & Green	NIPDAU	Level-3-260C-168 HR	0 to 70	TAS5112A	Samples
TAS5112ADFD	LIFEBUY	HTSSOP	DFD	56	35	RoHS & Green	NIPDAU	Level-3-260C-168 HR	0 to 70	5112A	
TAS5112ADFDR	LIFEBUY	HTSSOP	DFD	56	2000	RoHS & Green	NIPDAU	Level-3-260C-168 HR	0 to 70	5112A	

(1) The marketing status values are defined as follows:

ACTIVE: Product device recommended for new designs.

LIFEBUY: TI has announced that the device will be discontinued, and a lifetime-buy period is in effect.

NRND: Not recommended for new designs. Device is in production to support existing customers, but TI does not recommend using this part in a new design.

PREVIEW: Device has been announced but is not in production. Samples may or may not be available.

OBSOLETE: TI has discontinued the production of the device.

(2) **RoHS:** TI defines "RoHS" to mean semiconductor products that are compliant with the current EU RoHS requirements for all 10 RoHS substances, including the requirement that RoHS substance do not exceed 0.1% by weight in homogeneous materials. Where designed to be soldered at high temperatures, "RoHS" products are suitable for use in specified lead-free processes. TI may reference these types of products as "Pb-Free".

RoHS Exempt: TI defines "RoHS Exempt" to mean products that contain lead but are compliant with EU RoHS pursuant to a specific EU RoHS exemption.

Green: TI defines "Green" to mean the content of Chlorine (Cl) and Bromine (Br) based flame retardants meet JS709B low halogen requirements of <=1000ppm threshold. Antimony trioxide based flame retardants must also meet the <=1000ppm threshold requirement.

(3) MSL, Peak Temp. - The Moisture Sensitivity Level rating according to the JEDEC industry standard classifications, and peak solder temperature.

(4) There may be additional marking, which relates to the logo, the lot trace code information, or the environmental category on the device.

(5) Multiple Device Markings will be inside parentheses. Only one Device Marking contained in parentheses and separated by a "~" will appear on a device. If a line is indented then it is a continuation of the previous line and the two combined represent the entire Device Marking for that device.

(6) Lead finish/Ball material - Orderable Devices may have multiple material finish options. Finish options are separated by a vertical ruled line. Lead finish/Ball material values may wrap to two lines if the finish value exceeds the maximum column width.

Important Information and Disclaimer:The information provided on this page represents TI's knowledge and belief as of the date that it is provided. TI bases its knowledge and belief on information provided by third parties, and makes no representation or warranty as to the accuracy of such information. Efforts are underway to better integrate information from third parties. TI has taken and continues to take reasonable steps to provide representative and accurate information but may not have conducted destructive testing or chemical analysis on incoming materials and chemicals. TI and TI suppliers consider certain information to be proprietary, and thus CAS numbers and other limited information may not be available for release.

In no event shall TI's liability arising out of such information exceed the total purchase price of the TI part(s) at issue in this document sold by TI to Customer on an annual basis.

TAPE AND REEL INFORMATION

QUADRANT ASSIGNMENTS FOR PIN 1 ORIENTATION IN TAPE

*All dimensions are nominal

Device	Package Type	Package Drawing	Pins	SPQ	Reel Diameter (mm)	Reel Width W1 (mm)	A0 (mm)	B0 (mm)	K0 (mm)	P1 (mm)	W (mm)	Pin1 Quadrant
TAS5112ADFDR	HTSSOP	DFD	56	2000	330.0	24.4	8.6	15.6	1.8	12.0	24.0	Q1

TAPE AND REEL BOX DIMENSIONS

*All dimensions are nominal

Device	Package Type	Package Drawing	Pins	SPQ	Length (mm)	Width (mm)	Height (mm)
TAS5112ADFDR	HTSSOP	DFD	56	2000	350.0	350.0	43.0

TUBE



*All dimensions are nominal

Device	Package Name	Package Type	Pins	SPQ	L (mm)	W (mm)	T (μm)	B (mm)
TAS5112ADCA	DCA	HTSSOP	56	35	530	11.89	3600	4.9
TAS5112ADFD	DFD	HTSSOP	56	35	530	11.89	3600	4.9

MECHANICAL DATA

DCA (R-PDSO-G56)

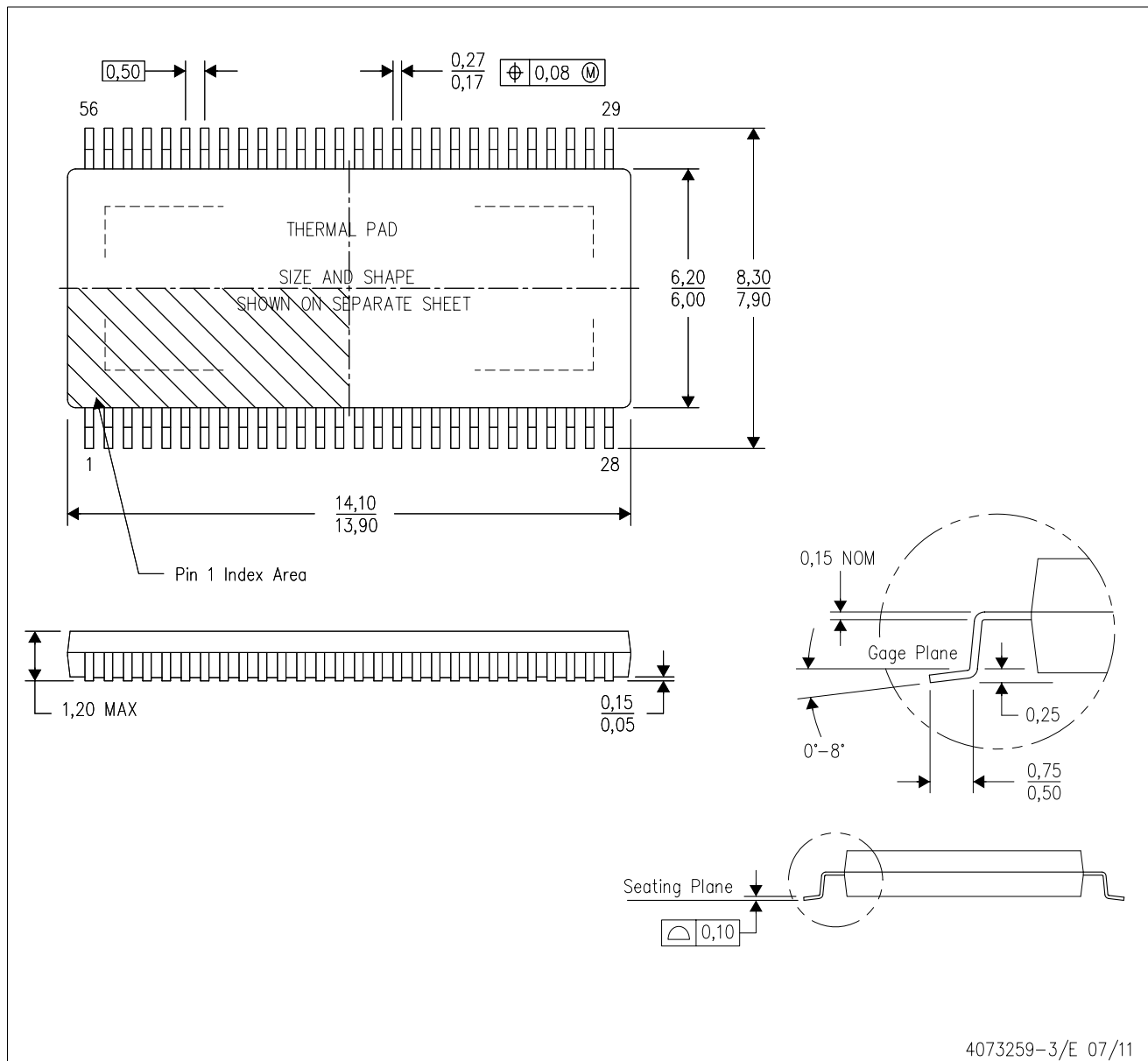
PowerPAD™ PLASTIC SMALL-OUTLINE



- NOTES:
- All linear dimensions are in millimeters. Dimensioning and tolerancing per ASME Y14.5M-1994.
 - This drawing is subject to change without notice.
 - Body dimensions do not include mold flash or protrusion not to exceed 0,15.
 - This package is designed to be soldered to a thermal pad on the board. Refer to Technical Brief, PowerPad Thermally Enhanced Package, Texas Instruments Literature No. SLMA002 for information regarding recommended board layout. This document is available at www.ti.com <<http://www.ti.com>>.
 - See the additional figure in the Product Data Sheet for details regarding the exposed thermal pad features and dimensions.
 - Falls within JEDEC MO-153

PowerPAD is a trademark of Texas Instruments.

THERMAL PAD MECHANICAL DATA

DCA (R-PDSO-G56)

PowerPAD™ PLASTIC SMALL OUTLINE

THERMAL INFORMATION

This PowerPAD™ package incorporates an exposed thermal pad that is designed to be attached to a printed circuit board (PCB). The thermal pad must be soldered directly to the PCB. After soldering, the PCB can be used as a heatsink. In addition, through the use of thermal vias, the thermal pad can be attached directly to the appropriate copper plane shown in the electrical schematic for the device, or alternatively, can be attached to a special heatsink structure designed into the PCB. This design optimizes the heat transfer from the integrated circuit (IC).

For additional information on the PowerPAD package and how to take advantage of its heat dissipating abilities, refer to Technical Brief, PowerPAD Thermally Enhanced Package, Texas Instruments Literature No. SLMA002 and Application Brief, PowerPAD Made Easy, Texas Instruments Literature No. SLMA004. Both documents are available at www.ti.com.

The exposed thermal pad dimensions for this package are shown in the following illustration.

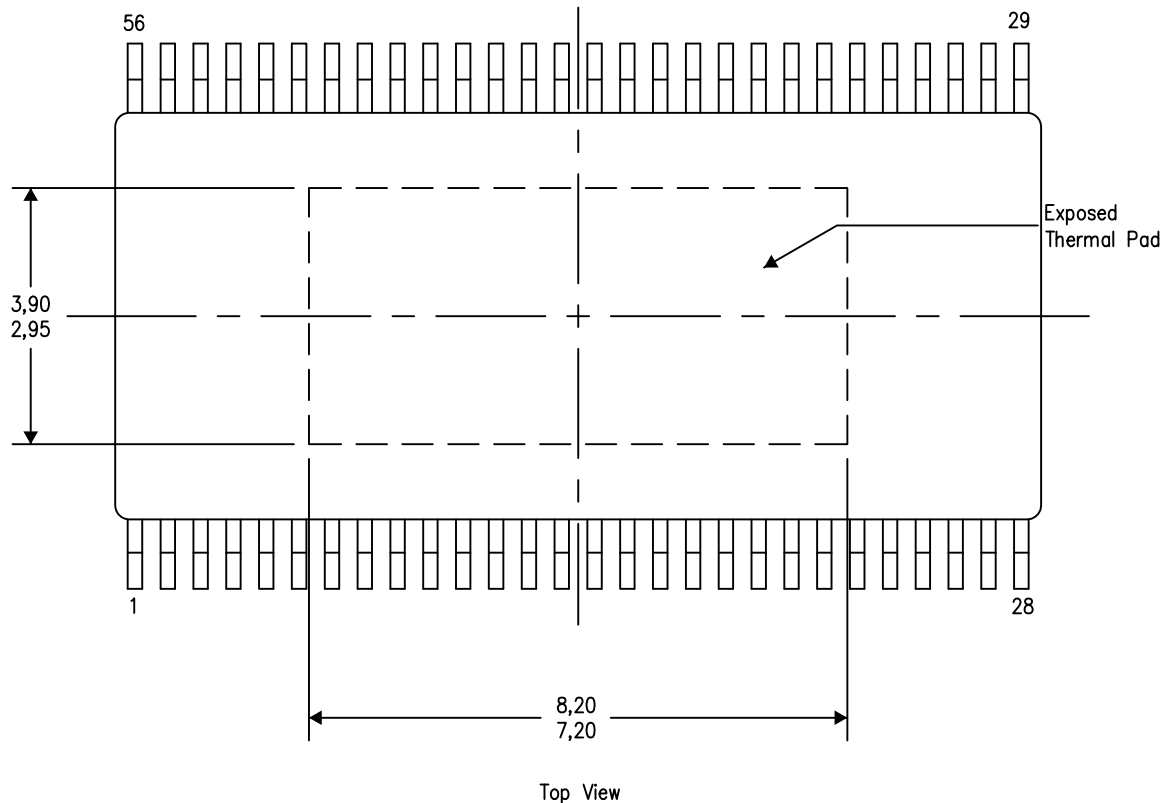

Exposed Thermal Pad Dimensions

4206320-8/S 11/14

NOTE: A. All linear dimensions are in millimeters

PowerPAD is a trademark of Texas Instruments.

MECHANICAL DATA

DFD (R-PDSO-G56)

PowerPAD™ PLASTIC SMALL-OUTLINE PACKAGE (DIE DOWN)

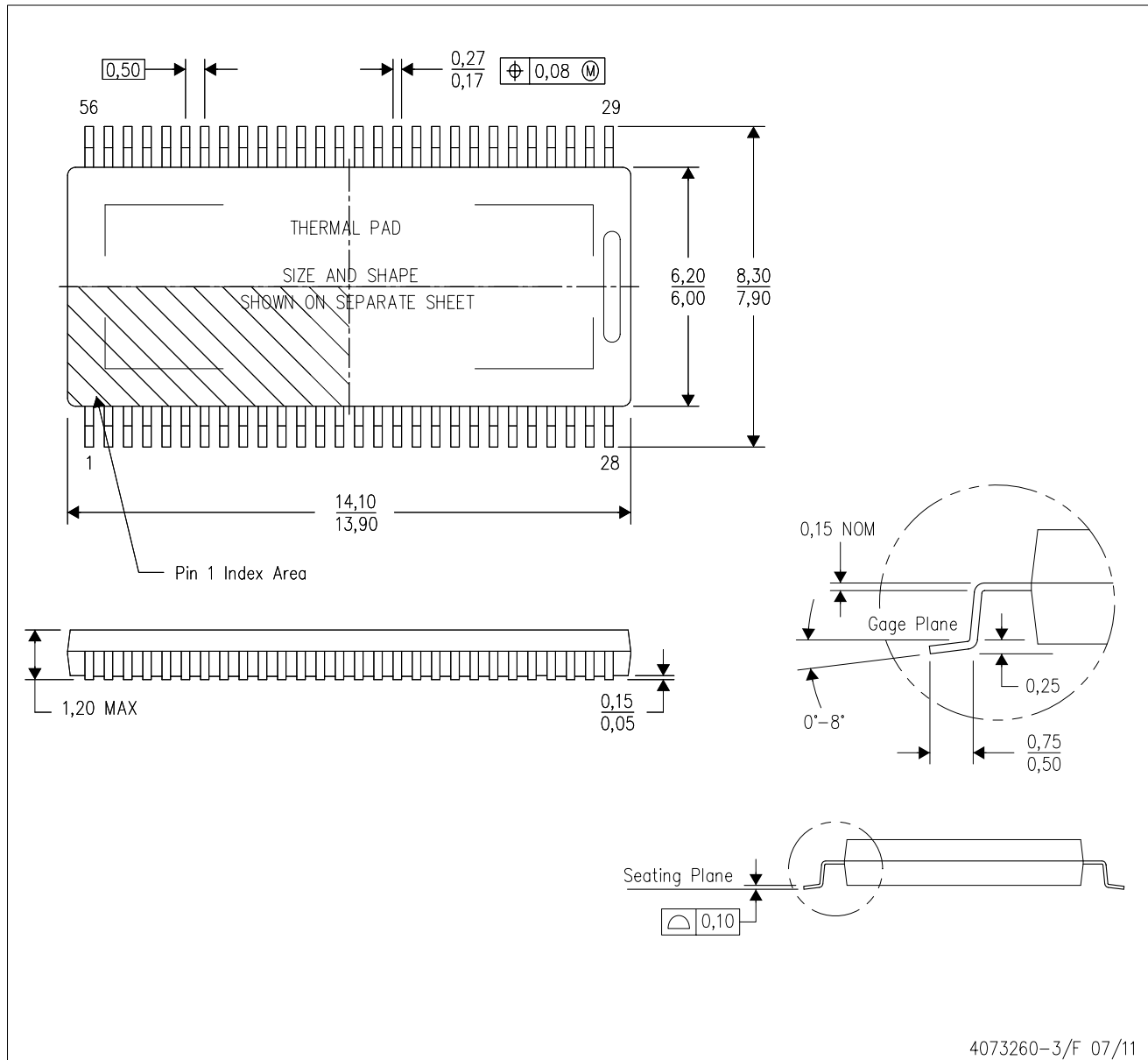

- NOTES:
- All linear dimensions are in millimeters. Dimensioning and tolerancing per ASME Y14.5M-1994.
 - This drawing is subject to change without notice.
 - Body dimensions do not include mold flash or protrusion not to exceed 0,15.
 - This package is designed to be soldered to a thermal pad on the board. Refer to Technical Brief, PowerPad Thermally Enhanced Package, Texas Instruments Literature No. SLMA002 for information regarding recommended board layout. This document is available at www.ti.com <<http://www.ti.com>>.
 - See the additional figure in the Product Data Sheet for details regarding the exposed thermal pad features and dimensions.
 - Falls within JEDEC MO-153

PowerPAD is a trademark of Texas Instruments.

IMPORTANT NOTICE AND DISCLAIMER

TI PROVIDES TECHNICAL AND RELIABILITY DATA (INCLUDING DATA SHEETS), DESIGN RESOURCES (INCLUDING REFERENCE DESIGNS), APPLICATION OR OTHER DESIGN ADVICE, WEB TOOLS, SAFETY INFORMATION, AND OTHER RESOURCES "AS IS" AND WITH ALL FAULTS, AND DISCLAIMS ALL WARRANTIES, EXPRESS AND IMPLIED, INCLUDING WITHOUT LIMITATION ANY IMPLIED WARRANTIES OF MERCHANTABILITY, FITNESS FOR A PARTICULAR PURPOSE OR NON-INFRINGEMENT OF THIRD PARTY INTELLECTUAL PROPERTY RIGHTS.

These resources are intended for skilled developers designing with TI products. You are solely responsible for (1) selecting the appropriate TI products for your application, (2) designing, validating and testing your application, and (3) ensuring your application meets applicable standards, and any other safety, security, regulatory or other requirements.

These resources are subject to change without notice. TI grants you permission to use these resources only for development of an application that uses the TI products described in the resource. Other reproduction and display of these resources is prohibited. No license is granted to any other TI intellectual property right or to any third party intellectual property right. TI disclaims responsibility for, and you will fully indemnify TI and its representatives against, any claims, damages, costs, losses, and liabilities arising out of your use of these resources.

TI's products are provided subject to [TI's Terms of Sale](#) or other applicable terms available either on [ti.com](https://www.ti.com) or provided in conjunction with such TI products. TI's provision of these resources does not expand or otherwise alter TI's applicable warranties or warranty disclaimers for TI products.

TI objects to and rejects any additional or different terms you may have proposed.

Mailing Address: Texas Instruments, Post Office Box 655303, Dallas, Texas 75265
Copyright © 2024, Texas Instruments Incorporated