

# TLC3555-Q1 Automotive High-Speed CMOS Timer

## 1 Features

- AEC-Q100 qualified for automotive applications:
  - Temperature grade 1:  $-40^{\circ}\text{C}$  to  $+125^{\circ}\text{C}$ ,  $T_A$
- [Functional Safety-Capable](#)
  - [Documentation available to aid functional safety system design](#)
- Very-low power consumption
  - 1mW (typical) at  $V_{DD} = 5\text{V}$
- Astable operation up to 3MHz
- CMOS output capable of swinging rail to rail
- High-output-current capability
  - Sink 200mA
  - Source 50mA
- Output fully compatible with CMOS, TTL, and MOS logic
- Integrated RESET pullup to  $V_{DD}$
- Power-on reset to known state
- Integrated thermal shutdown protection
- Single-supply operation from 1.5V to 18V

## 2 Applications

- [Automotive lighting](#)
- [Vehicle instrument cluster](#)
- [Telematics](#)
- Pulse generation
- Sequential timing
- Time delay generation
- Pulse width modulation
- Pulse position modulation
- MOSFET gate drive

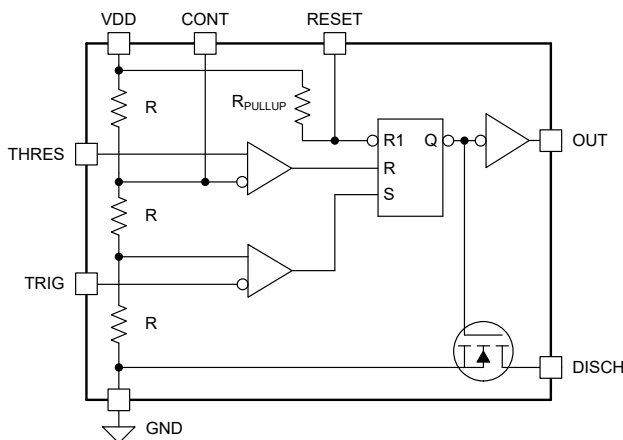

Simplified Schematic

## 3 Description

The TLC3555-Q1 is a monolithic timing circuit fabricated using a TI CMOS process. The timer is fully compatible with CMOS, TTL, and MOS logic and operates at frequencies to 3MHz and even beyond. The TLC3555-Q1 improves upon the existing [TLC555-Q1](#) from both a performance and feature standpoint, with tighter specification tolerances and additional features, such as thermal shutdown and power-on reset.

The trigger, threshold, and reset logic of the TLC3555-Q1 follow the same truth table as the TLC555-Q1. Set the reset pin (RESET) high for typical operation, or set the reset pin low to reset the flip-flop and force the output low. The TLC3555-Q1 features an internal pullup resistor from RESET to  $V_{DD}$ , which can reduce passive count and save board area.

As a result of low propagation delay and rapid rise and fall times, the TLC3555-Q1 supports higher-frequency astable operation than previous timers such as the NE555 and TLC555-Q1. At a 15V supply, the TLC3555-Q1 achieves a clean square wave at 3.1MHz in TI's conventional astable test circuit. When used as an oscillator, with the output and inputs tied together, the TLC3555-Q1 achieves an oscillatory frequency of 7.2MHz. Circuit parasitics dominate the response at high frequencies. In addition to the D package, which is pin-to-pin compatible with the TLC555-Q1, the TLC3555-Q1 is offered in a DDF package that enables concise implementations with reduced parasitics.

### Package Information

PART NUMBER	PACKAGE <sup>(1)</sup>	PACKAGE SIZE <sup>(2)</sup>
TLC3555-Q1	D (SOIC, 8)	4.9mm × 6.0mm
	DDF (SOT-23-THIN, 8) <sup>(3)</sup>	2.9mm × 2.8mm

- (1) For more information, see [Section 10](#).
- (2) The package size (length × width) is a nominal value and includes pins, where applicable.
- (3) Advance information (not Production Data).



## Table of Contents

<b>1 Features</b> .....	1	6.4 Device Functional Modes.....	13
<b>2 Applications</b> .....	1	<b>7 Application and Implementation</b> .....	14
<b>3 Description</b> .....	1	7.1 Application Information.....	14
<b>4 Pin Configuration and Functions</b> .....	2	7.2 Typical Applications.....	14
<b>5 Specifications</b> .....	3	7.3 Power Supply Recommendations.....	16
5.1 Absolute Maximum Ratings.....	3	7.4 Layout.....	16
5.2 ESD Ratings .....	3	<b>8 Device and Documentation Support</b> .....	18
5.3 Recommended Operating Conditions.....	3	8.1 Documentation Support.....	18
5.4 Thermal Information.....	3	8.2 Receiving Notification of Documentation Updates....	18
5.5 Electrical Characteristics.....	4	8.3 Support Resources.....	18
5.6 Switching Characteristics.....	6	8.4 Trademarks.....	18
5.7 Typical Characteristics.....	7	8.5 Electrostatic Discharge Caution.....	18
<b>6 Detailed Description</b> .....	9	8.6 Glossary.....	18
6.1 Overview.....	9	<b>9 Revision History</b> .....	18
6.2 Functional Block Diagram.....	9	<b>10 Mechanical, Packaging, and Orderable Information</b> .....	18
6.3 Feature Description.....	9		

## 4 Pin Configuration and Functions

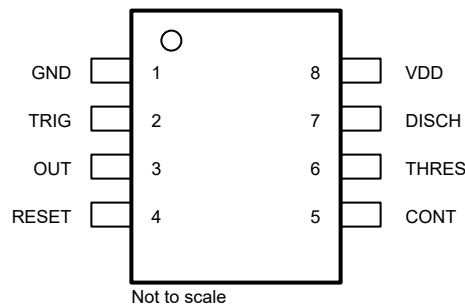

Figure 4-1. D Package, 8-Pin SOIC, and DDF (Preview) Package, 8-Pin SOT-23-THIN (Top View)

Table 4-1. Pin Functions

PIN		TYPE	DESCRIPTION
NAME	NO.		
CONT	5	Input/Output	Controls comparator thresholds. Outputs 2/3 V <sub>DD</sub> by default, or can be driven externally
DISCH	7	Output	Open collector output to discharge timing capacitor
GND	1	Power	Ground reference voltage
OUT	3	Output	Timer output signal
RESET	4	Input	Active low reset input forces output and discharge low
THRES	6	Input	End of timing input. THRES > CONT sets output low and discharge low
TRIG	2	Input	Start of timing input. TRIG < 1/2 CONT sets output high and discharge open
VDD	8	Power	Input supply voltage, 1.5V to 18V

## 5 Specifications

### 5.1 Absolute Maximum Ratings

over operating free-air temperature range (unless otherwise noted) <sup>(1)</sup>

		MIN	MAX	UNIT
V <sub>DD</sub>	Supply voltage <sup>(2)</sup>	-0.3	20	V
	Input voltage on TRIG, THRES, CONT, RESET pins	-0.3	V <sub>DD</sub> + 0.3	V
I <sub>OL</sub>	Sink current, discharge or output		225	mA
I <sub>OH</sub>	Source current, output		60	mA
T <sub>A</sub>	Operating free-air temperature	-55	125	°C
T <sub>J</sub>	Junction temperature	-55	150	°C
T <sub>stg</sub>	Storage temperature	-65	150	°C

- (1) Operation outside the *Absolute Maximum Ratings* may cause permanent device damage. *Absolute Maximum Ratings* do not imply functional operation of the device at these or any other conditions beyond those listed under *Recommended Operating Conditions*. If used outside the *Recommended Operating Conditions* but within the *Absolute Maximum Ratings*, the device may not be fully functional, and this may affect device reliability, functionality, performance, and shorten the device lifetime.
- (2) All voltage values are with respect to network GND.

### 5.2 ESD Ratings

			VALUE	UNIT
V <sub>(ESD)</sub>	Electrostatic discharge	Human-body model (HBM), per AEC Q100-002 <sup>(1)</sup>	±2000	V
		Charged-device model (CDM), per AEC Q100-011	±500	

- (1) AEC Q100-002 indicates that HBM stressing shall be in accordance with the ANSI/ESDA/JEDEC JS-001 specification.

### 5.3 Recommended Operating Conditions

over operating free-air temperature range (unless otherwise noted)

		MIN	NOM	MAX	UNIT
V <sub>DD</sub>	Supply voltage	1.5		18	V
T <sub>A</sub>	Operating free-air temperature	-40		125	°C

### 5.4 Thermal Information

THERMAL METRICS <sup>(1)</sup>		TLC3555-Q1		UNIT
		8 PINS		
		D (SOIC)	DDF (SOT-23-THIN)	
R <sub>θJA</sub>	Junction-to-ambient thermal resistance	138.9	211.3	°C/W
R <sub>θJC(top)</sub>	Junction-to-case (top) thermal resistance	78.8	118.0	°C/W
R <sub>θJB</sub>	Junction-to-board thermal resistance	87.9	112.1	°C/W
ψ <sub>JT</sub>	Junction-to-top characterization parameter	23.2	15.2	°C/W
ψ <sub>JB</sub>	Junction-to-board characterization parameter	86.9	111.7	°C/W
R <sub>θJC(bot)</sub>	Junction-to-case (bottom) thermal resistance	N/A	N/A	°C/W

- (1) For more information about traditional and new thermal metrics, see the [Semiconductor and IC Package Thermal Metrics](#) application report.

### 5.5 Electrical Characteristics

at  $T_A = 25^\circ\text{C}$  and  $V_{DD} = 5\text{V}$  (unless otherwise noted)

PARAMETER		TEST CONDITIONS		MIN	TYP	MAX	UNIT
$V_{I(\text{THRES})}$	Threshold voltage	$V_{DD} = 1.5\text{V}$		0.95	1.0	1.05	V
			$-40^\circ\text{C to }+125^\circ\text{C}$	0.8	1.0	1.15	
		$V_{DD} = 3.3\text{V}$		2.1	2.2	2.3	
			$-40^\circ\text{C to }+125^\circ\text{C}$	2	2.2	2.4	
		$V_{DD} = 5\text{V}$		3.28	3.33	3.38	
			$-40^\circ\text{C to }+125^\circ\text{C}$	3.2	3.33	3.46	
		$V_{DD} = 12\text{V}$		7.92	8	8.08	
			$-40^\circ\text{C to }+125^\circ\text{C}$	7.7	8	8.3	
		$V_{DD} = 15\text{V}$		9.9	10	10.1	
			$-40^\circ\text{C to }+125^\circ\text{C}$	9.6	10	10.4	
$I_{I(\text{THRES})}$	Threshold current	$V_{DD} = 1.5\text{V to }15\text{V}$			10	pA	
			$-40^\circ\text{C to }+125^\circ\text{C}$				1000
$V_{I(\text{TRIG})}$	Trigger voltage	$V_{DD} = 1.5\text{V}$		0.48	0.5	0.52	V
			$-40^\circ\text{C to }+125^\circ\text{C}$	0.42	0.5	0.58	
		$V_{DD} = 3.3\text{V}$		1.06	1.1	1.14	
			$-40^\circ\text{C to }+125^\circ\text{C}$	1	1.1	1.2	
		$V_{DD} = 5\text{V}$		1.64	1.67	1.70	
			$-40^\circ\text{C to }+125^\circ\text{C}$	1.6	1.67	1.75	
		$V_{DD} = 12\text{V}$		3.95	4	4.05	
			$-40^\circ\text{C to }+125^\circ\text{C}$	3.85	4	4.15	
		$V_{DD} = 15\text{V}$		4.94	5	5.06	
			$-40^\circ\text{C to }+125^\circ\text{C}$	4.8	5	5.2	
$I_{I(\text{TRIG})}$	Trigger current	$V_{DD} = 1.5\text{V to }15\text{V}$			10	pA	
			$-40^\circ\text{C to }+125^\circ\text{C}$				1000
$V_{I(\text{RESET})}$	Reset voltage	$V_{DD} = 1.5\text{V}$		0.35	0.6	0.8	V
			$-40^\circ\text{C to }+125^\circ\text{C}$	0.3	0.6	1	
		$V_{DD} = 3.3\text{V}$		0.5	0.77	1.05	
			$-40^\circ\text{C to }+125^\circ\text{C}$	0.4	0.77	1.2	
		$V_{DD} = 5\text{V}$		0.65	0.86	1.3	
			$-40^\circ\text{C to }+125^\circ\text{C}$	0.5	0.86	1.4	
		$V_{DD} = 12\text{V}$		0.67	0.89	1.3	
			$-40^\circ\text{C to }+125^\circ\text{C}$	0.5	0.89	1.4	
		$V_{DD} = 15\text{V}$		0.67	0.89	1.3	
			$-40^\circ\text{C to }+125^\circ\text{C}$	0.5	0.89	1.4	
$I_{I(\text{RESET})}$	Reset current	$V_{DD} = 1.5\text{V to }15\text{V},$ $\text{RESET} = V_{DD}$			10	pA	
			$-40^\circ\text{C to }+125^\circ\text{C}$				1000
		$V_{DD} = 1.5\text{V}, \text{RESET} = 0\text{V}$				1.8	$\mu\text{A}$
			$-40^\circ\text{C to }+125^\circ\text{C}$			1.9	
		$V_{DD} = 3.3\text{V}, \text{RESET} = 0\text{V}$				3.9	
			$-40^\circ\text{C to }+125^\circ\text{C}$			4	
		$V_{DD} = 5\text{V}, \text{RESET} = 0\text{V}$				5.9	
			$-40^\circ\text{C to }+125^\circ\text{C}$			6	
		$V_{DD} = 12\text{V}, \text{RESET} = 0\text{V}$				14.2	
			$-40^\circ\text{C to }+125^\circ\text{C}$			14.4	
$V_{DD} = 15\text{V}, \text{RESET} = 0\text{V}$				17.8			
	$-40^\circ\text{C to }+125^\circ\text{C}$			18			
$V_{I(\text{CONT})}$	Control voltage	Open circuit, expressed as a percentage of supply voltage			66.7	%	

## 5.5 Electrical Characteristics (continued)

at  $T_A = 25^\circ\text{C}$  and  $V_{DD} = 5\text{V}$  (unless otherwise noted)

PARAMETER		TEST CONDITIONS		MIN	TYP	MAX	UNIT
	Discharge switch on-stage voltage	$I_{OL} = 1\text{mA}$ , $V_{DD} = 1.5\text{V to }15\text{V}$	$-40^\circ\text{C to }+125^\circ\text{C}$		0.025	0.2	V
					0.03	0.25	
		$I_{OL} = 10\text{mA}$ , $V_{DD} = 3.3\text{V to }15\text{V}$	$-40^\circ\text{C to }+125^\circ\text{C}$		0.08	0.3	
	Discharge switch off-stage current	$V_{DD} = 1.5\text{V to }15\text{V}$			0.01		nA
			$-40^\circ\text{C to }+125^\circ\text{C}^{(3)}$			70	
$V_{OH}$	High-level output voltage	$I_{OH} = -1\text{mA}$ , $V_{DD} = 1.5\text{V}$			1.05	1.29	V
			$-40^\circ\text{C to }+125^\circ\text{C}$			1.05	
		$I_{OH} = -1\text{mA}$ , $V_{DD} = 3.3\text{V}$			2.9	3.25	
			$-40^\circ\text{C to }+125^\circ\text{C}$			2.9	
		$I_{OH} = -1\text{mA}$ , $V_{DD} = 5\text{V}$			4.67	4.91	
			$-40^\circ\text{C to }+125^\circ\text{C}$			4.6	
		$I_{OH} = -10\text{mA}$ , $V_{DD} = 5\text{V}$			4.2	4.58	
			$-40^\circ\text{C to }+125^\circ\text{C}$			4.09	
$I_{OH} = -10\text{mA}$ , $V_{DD} = 12\text{V}$			11.2	11.54			
	$-40^\circ\text{C to }+125^\circ\text{C}$			11	11.4		
$I_{OH} = -10\text{mA}$ , $V_{DD} = 15\text{V}$			14.2	14.54			
	$-40^\circ\text{C to }+125^\circ\text{C}$			14	14.2		
$I_{OH} = -50\text{mA}$ , $V_{DD} = 15\text{V}$			10.5	11.5			
	$-40^\circ\text{C to }+125^\circ\text{C}^{(4)}$			9			
$V_{OL}$	Low-level output voltage	$I_{OL} = 1\text{mA}$ , $1.5\text{V}$			0.1	0.25	V
			$-40^\circ\text{C to }+125^\circ\text{C}$			0.2	
		$I_{OL} = 1\text{mA}$ , $3.3\text{V}$			0.09	0.25	
			$-40^\circ\text{C to }+125^\circ\text{C}$			0.2	
		$I_{OL} = 1\text{mA}$ , $V_{DD} = 5\text{V to }15\text{V}$			0.08	0.2	
			$-40^\circ\text{C to }+125^\circ\text{C}$			0.2	
		$I_{OL} = 10\text{mA}$ , $V_{DD} = 3.3\text{V}$			0.25	0.3	
			$-40^\circ\text{C to }+125^\circ\text{C}$			0.3	
$I_{OL} = 10\text{mA}$ , $V_{DD} = 5\text{V to }15\text{V}$			0.17	0.3			
	$-40^\circ\text{C to }+125^\circ\text{C}$			0.25	0.4		
$I_{OL} = 100\text{mA}$ , $V_{DD} = 5\text{V to }15\text{V}^{(4)}$			2.11	2.8			
	$-40^\circ\text{C to }+125^\circ\text{C}$			2.5	3.2		
$I_{OL} = 200\text{mA}$ , $V_{DD} = 15\text{V}^{(4)}$			5	6			
	$-40^\circ\text{C to }+125^\circ\text{C}$			7			
$C_I$	Trigger, threshold capacitance (each pin)				2.1		pF
$C_{PD}$	Power dissipation capacitance <sup>(1)</sup> <sup>(2)</sup>				50		pF

## 5.5 Electrical Characteristics (continued)

at  $T_A = 25^\circ\text{C}$  and  $V_{DD} = 5\text{V}$  (unless otherwise noted)

PARAMETER		TEST CONDITIONS		MIN	TYP	MAX	UNIT	
$I_Q$	Quiescent current	$V_{DD} = 1.5\text{V}$			150	200	$\mu\text{A}$	
			$-40^\circ\text{C}$ to $+125^\circ\text{C}$		180	285		
		$V_{DD} = 3.3\text{V}$			180	250		
			$-40^\circ\text{C}$ to $+125^\circ\text{C}$		210	330		
		$V_{DD} = 5\text{V}$			200	270		
			$-40^\circ\text{C}$ to $+125^\circ\text{C}$		240	365		
$V_{DD} = 12\text{V}$			240	310				
	$-40^\circ\text{C}$ to $+125^\circ\text{C}$		290	425				
$V_{DD} = 15\text{V}$			260	330				
	$-40^\circ\text{C}$ to $+125^\circ\text{C}$		310	465				

- $C_{PD}$  is used to determine the dynamic power consumption.
- $P_D = V_{DD}^2 f_o(C_{PD} + C_L)$  where  $f_o$  = output frequency,  $C_L$  = output load capacitance,  $V_{DD}$  = supply voltage.
- Leakage increases with temperature, approximately doubling in magnitude with each  $10^\circ\text{C}$  rise in temperature. Value specified for Full Range is measured at  $T_A = 125^\circ\text{C}$ .
- Sustained operation at this output current results in self-heating that can cause the device to go into protective thermal shutdown, depending on the supply voltage and ambient temperature. Limit operation at high output current to only short durations, such as transient events.

## 5.6 Switching Characteristics

at  $T_A = 25^\circ\text{C}$  and  $V_{DD} = 5\text{V}$  (unless otherwise noted); characteristic values are specified by design, characterization, or both

PARAMETER		TEST CONDITIONS		MIN	TYP	MAX	UNIT
	Temperature sensitivity of timing interval	$T_A = -40^\circ\text{C}$ to $+125^\circ\text{C}$ , $C_T = 0.1\mu\text{F}$ , $R_A = R_B = 1\text{k}\Omega$ to $100\text{k}\Omega$ <sup>(2)</sup>			75		$\text{ppm}/^\circ\text{C}$
	Supply voltage sensitivity of timing interval	$V_+ = 3.3\text{V}$ to $15\text{V}$ , $C_T = 0.1\mu\text{F}$ , $R_A = R_B = 1\text{k}\Omega$ to $100\text{k}\Omega$			0.17		$\%/V$
$t_r$	Output pulse rise time	$R_L = 10\text{M}\Omega$ , $C_L = 10\text{pF}$			7.8		ns
$t_f$	Output pulse fall time	$R_L = 10\text{M}\Omega$ , $C_L = 10\text{pF}$			4.7		ns
$f_{\text{max}}$	Maximum frequency, astable mode <sup>(1)</sup>	$R_A = 470\Omega$ , $R_B = 200\Omega$ , $C_T = 200\text{pF}$		2.6	3		MHz
			$V_{DD} = 15\text{V}$		3.1		
		Free-running oscillator, THRES = TRIG = OUT			7.2		
$t_{PD}$	Trigger propagation delay	Rising	$V_{DD} = 3.3\text{V}$		85		ns
			$V_{DD} = 5\text{V}$		75		
			$V_{DD} = 15\text{V}$		60		
		Falling	$V_{DD} = 3.3\text{V}$		70		
			$V_{DD} = 5\text{V}$		50		
			$V_{DD} = 15\text{V}$		50		

- This measurement is significantly impacted by board parasitics.
- Calculated as  $(f_{125^\circ\text{C}} - f_{-40^\circ\text{C}}) / (\Delta T_A \times f_{25^\circ\text{C}}) \times 10^6$  where  $f_T$  = output frequency at temperature T, and  $T_A = -40^\circ\text{C}$  to  $+125^\circ\text{C}$ .

### 5.7 Typical Characteristics

at  $T_A = 25^\circ\text{C}$  and  $V_{DD} = 5\text{V}$  (unless otherwise noted)

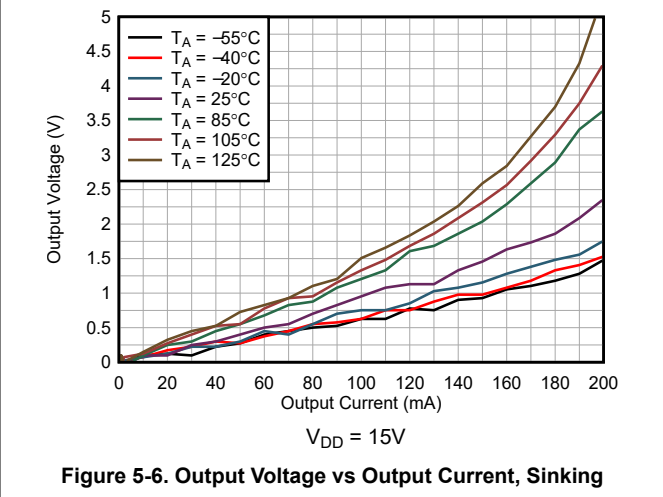
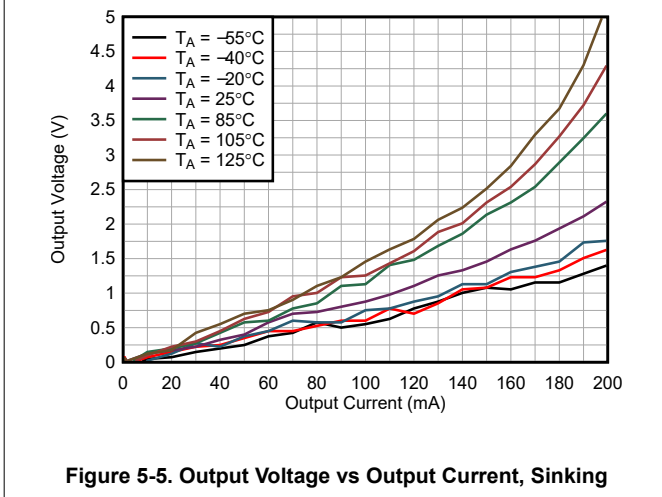
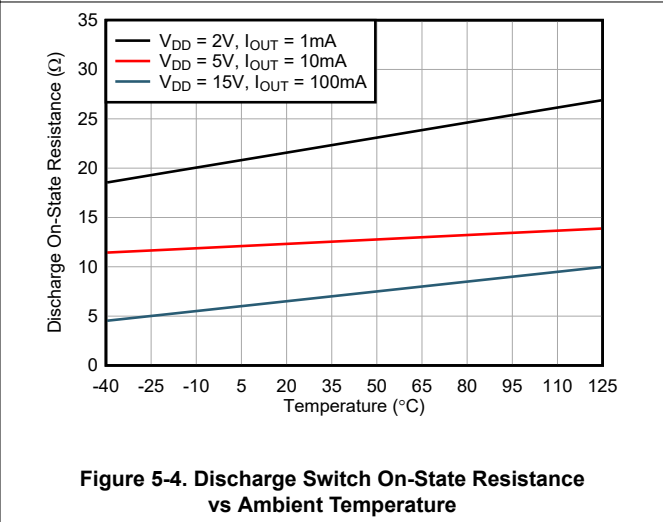
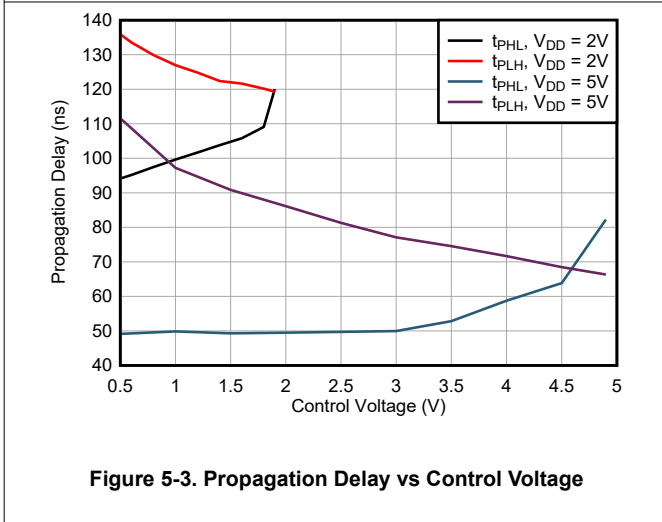
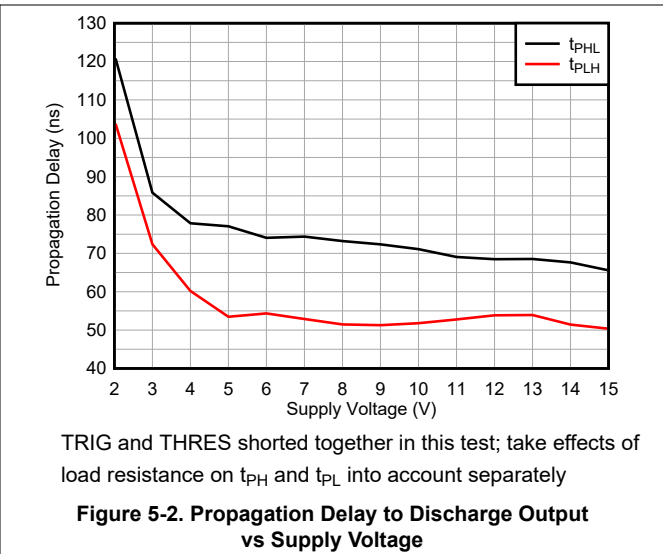
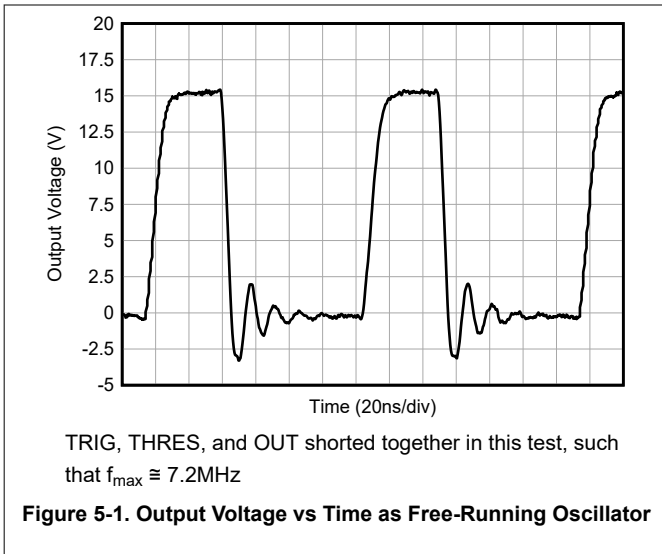

### 5.7 Typical Characteristics (continued)

at  $T_A = 25^\circ\text{C}$  and  $V_{DD} = 5\text{V}$  (unless otherwise noted)

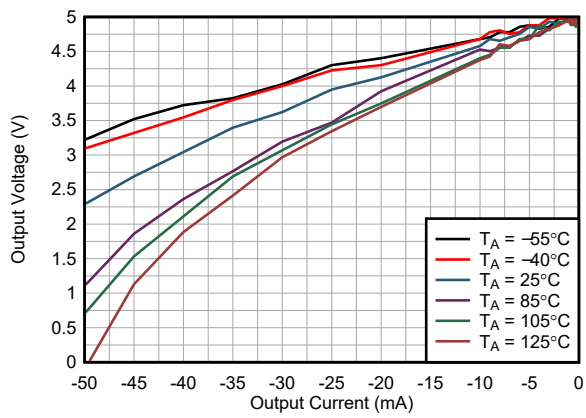

Figure 5-7. Output Voltage vs Output Current, Sourcing

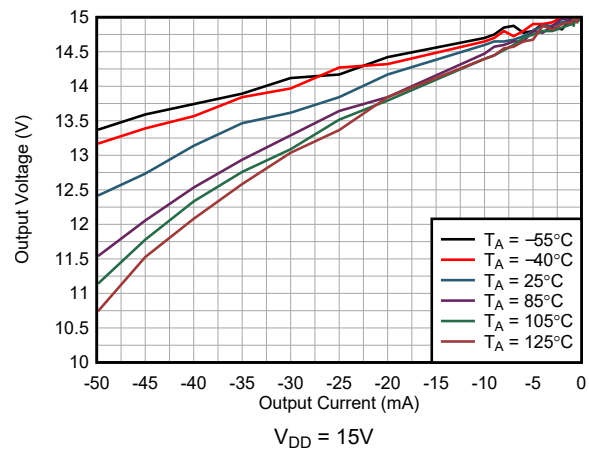

Figure 5-8. Output Voltage vs Output Current, Sourcing

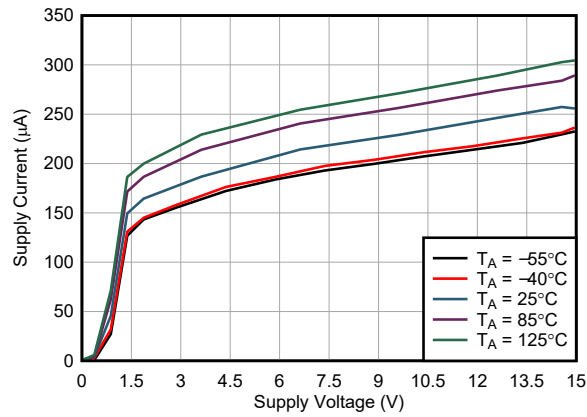

Figure 5-9. Supply Current vs Supply Voltage



## 6 Detailed Description

### 6.1 Overview

The TLC3555-Q1 next-generation timer is useful for both general-purpose and precise timing applications, with astable mode periods from 325ns to hours, and frequencies to 3MHz or even beyond. In nearly all cases, the tolerances of the passive components used to implement the application circuit contribute more error than the TLC3555-Q1 tolerance. The improved precision of the TLC3555-Q1 as compared to previous-generation timers provides a performance benefit to the trigger and threshold tolerances when using the same grade of passive components, or can enable similar end tolerances while using lower-grade passives for a cost benefit.

### 6.2 Functional Block Diagram

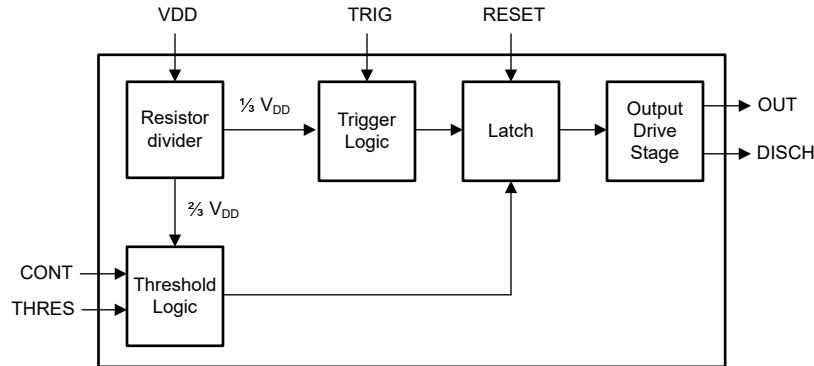

### 6.3 Feature Description

#### 6.3.1 Monostable Operation

For monostable operation, connect the TLC3555-Q1 as in [Figure 6-1](#). If the output is low, application of a negative-going pulse to the trigger (TRIG) sets the internal flip-flop, drives the output high, and turns off DISCH. Capacitor  $C_T$  charges through  $R_A$  until the voltage across the capacitor reaches the threshold voltage of the threshold (THRES) input. If TRIG returns to a high level, the output of the threshold comparator resets the flip-flop, drives the output low, and discharges  $C_T$  through DISCH.

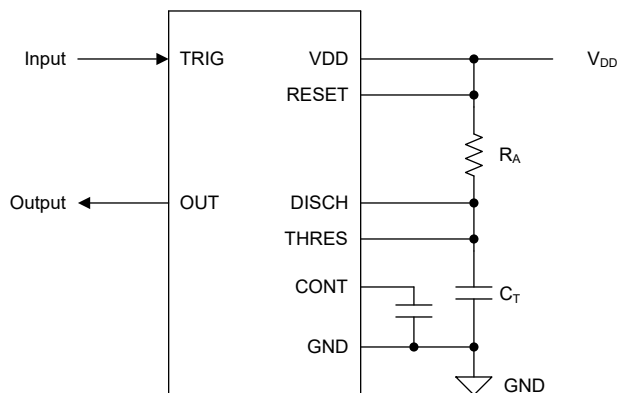

**Figure 6-1. Circuit for Monostable Operation**

Monostable operation initiates when the TRIG voltage is less than the trigger threshold. After initialization, the sequence ends only if TRIG is high for at least 500ns before the end of the timing interval. When the trigger is grounded, the comparator storage time can be as long as 500ns, which limits the minimum monostable pulse width to 500ns. As a result of the threshold level and saturation voltage of the discharge transistor, the output pulse duration is approximately  $t_w = 1.1 \times R_A \times C_T$ . [Figure 6-3](#) is a plot of the nominal pulse width for various values of  $R_A$  and  $C_T$ . The threshold levels and charge rates are directly proportional to the supply voltage ( $V_{DD}$ ). As a result, the timing interval is independent of the supply voltage if the supply voltage is constant during the time interval.

Apply a negative-going trigger pulse simultaneously to RESET and TRIG during the timing interval to discharge  $C_T$  and reinitiate the cycle, commencing on the positive edge of the reset pulse. The output is held low for as long as the reset pulse is low.

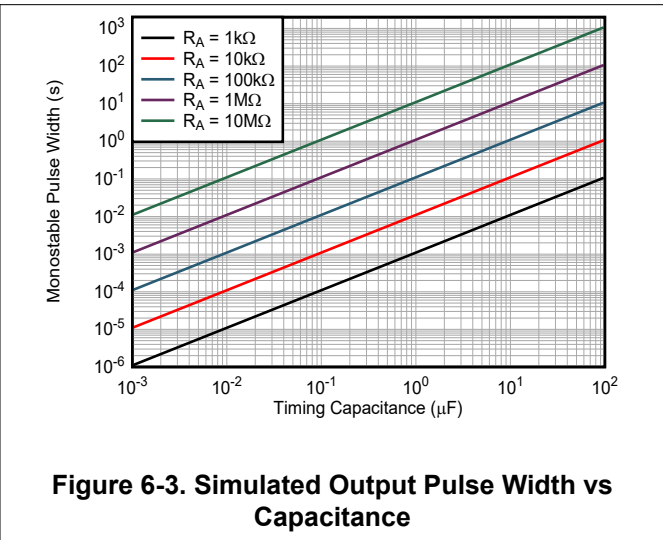
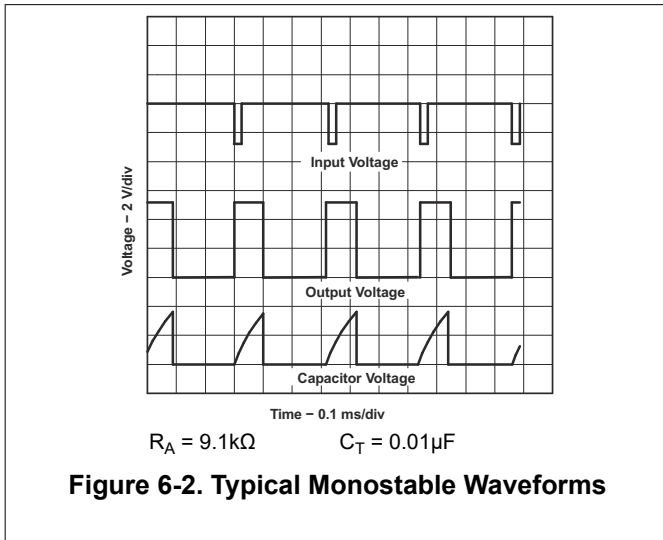

### 6.3.2 Astable Operation

Figure 6-4 shows that adding a second resistor ( $R_B$ ) to the circuit and connecting the trigger input to the threshold input causes the timer to self-trigger and run as a multivibrator. The  $C_T$  capacitor charges through  $R_A$  and  $R_B$  and then only discharges through  $R_B$ . As a result, the values of  $R_A$  and  $R_B$  control the duty cycle.  $D_B$  is optional and typically used only when a duty cycle below 50% is required, as the diode bypasses  $R_B$  to allow faster charging of  $C_T$ .

This astable connection results in the  $C_T$  capacitor charging and discharging between the threshold-voltage level ( $\cong 0.67 \times V_{DD}$ ) and the trigger-voltage level ( $\cong 0.33 \times V_{DD}$ ). Driving the CONT pin externally shifts the threshold-voltage and trigger-voltage levels to  $V_{CONT}$  and  $0.5 \times V_{CONT}$ , respectively. As in the monostable circuit, charge and discharge times (and as a result, the frequency and duty cycle) are independent of the supply voltage.

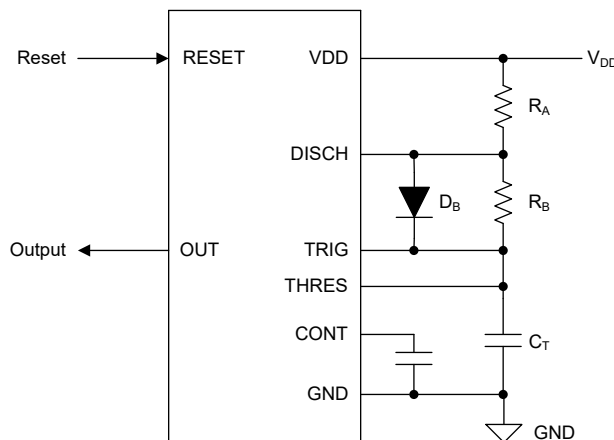

**Figure 6-4. Circuit for Astable Operation**

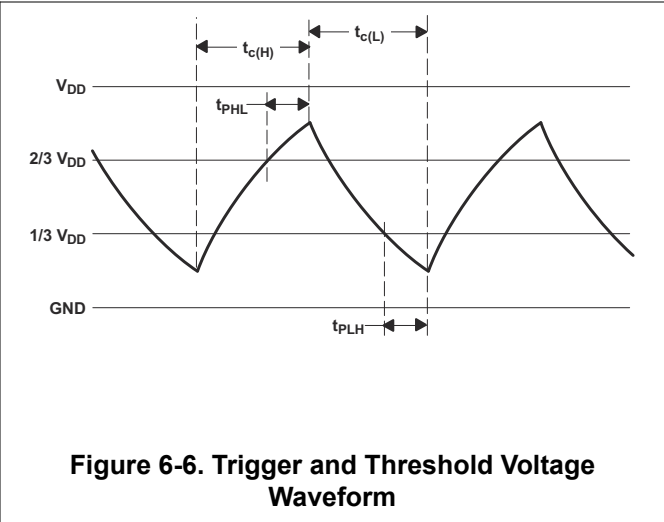
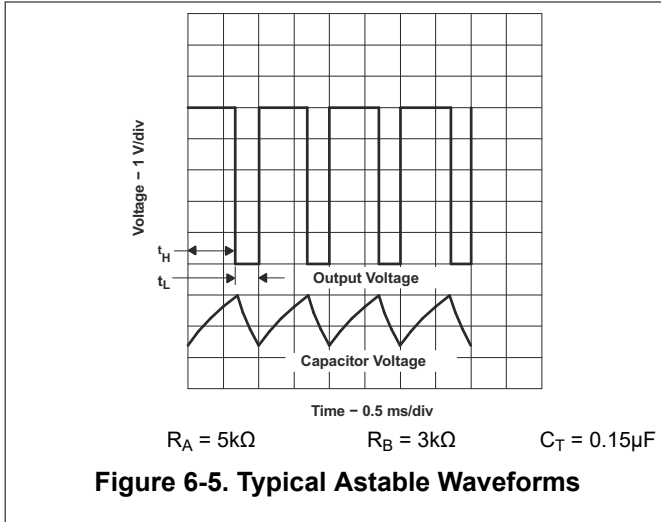

Figure 6-6 shows typical waveforms generated during astable operation. The output high-level duration ( $t_H$ ) and low-level duration  $t_L$  can be calculated as follows:

$$t_H = 0.693 \times (R_A + R_B) \times C_T \quad (1)$$

$$t_L = 0.693 \times R_B \times C_T \quad (2)$$

Other useful relationships for period, frequency, and driver-referred and waveform-referred duty cycle are shown as follows:

$$T = t_H + t_L = 0.693 \times (R_A + 2R_B) \times C_T \quad (3)$$

$$f = \frac{1}{T} \cong \frac{1.44}{(R_A + 2R_B) \times C_T} \quad (4)$$

$$\text{Output driver duty cycle} = \frac{t_L}{T} = \frac{R_B}{R_A + 2R_B} \quad (5)$$

$$\text{Output waveform duty cycle} = \frac{t_H}{T} = 1 - \frac{R_B}{R_A + 2R_B} = \frac{R_A + R_B}{R_A + 2R_B} \quad (6)$$

These equations do not account for any propagation delay times from the TRIG and THRES inputs to DISCH output. These delay times add directly to the period and overcharge the capacitor, creating differences between calculated and actual values that increase with frequency. In addition, the discharge on-state resistance  $r_{on}$  during the discharge event contributes another source of timing error in the calculation when  $R_B$  is very low. The following equations provide better agreement with measured values. Equation 7 and Equation 8 represent the actual low and high times when used at higher frequencies (at 100kHz and beyond) because propagation delay and discharge on resistance is added to the formulas. The value of  $C_T$  includes both the nominal or deliberate timing capacitance, as well as parasitic capacitance on the PCB. Decoupling capacitance on CONT also affects the duty cycle, with an error contribution that depends on the capacitor leakage resistance. For additional discussion, see the [Design low-duty-cycle timer circuits article](#).

$$t_{c(H)} = C_T \times (R_A + R_B) \times \ln\left(3 - e\left(\frac{-t_{PD \text{ rising}}}{C_T \times (R_B + r_{on})}\right)\right) + t_{PD \text{ falling}} \quad (7)$$

$$t_{c(L)} = C_T \times (R_B + r_{on}) \times \ln\left(3 - e\left(\frac{-t_{PD \text{ falling}}}{C_T \times (R_A + R_B)}\right)\right) + t_{PD \text{ rising}} \quad (8)$$

These equations and those given earlier are similar in that a time constant is multiplied by the logarithm of a number or function. The limit values of the logarithmic terms must be between  $\ln(2)$  at low frequencies, and  $\ln(3)$  at extremely high frequencies. For a duty cycle close to 50%, an appropriate constant for the logarithmic terms can be substituted with good results. Output waveform duty cycles less than 50% require that  $t_{c(H)} / t_{c(L)} < 1$  and possibly that  $R_A \leq r_{on}$ . These conditions can be difficult to obtain.  $D_B$  can be used to reduce the effective  $R_B$  during the capacitor charging event, but has a nonlinear response. If using  $D_B$ , verify performance through simulation and bench evaluation before selecting final timing component values.

Figure 6-7 and Figure 6-8 show the nominal free-running frequency associated with various combinations of  $C_T$  and  $R_A + 2 \times R_B$  for a 66% duty cycle (such that  $R_A = R_B$ ). The values of  $r_{on}$ ,  $t_{PD \text{ falling}}$  and  $t_{PD \text{ rising}}$  vary according to the device supply voltage and temperature. Tolerances of  $R_A$ ,  $R_B$ , and  $C_T$  also contribute variation. The difference of simulation results calculated using the simplified and detailed equations becomes apparent by 100kHz, with approximately 2.15% error at  $V_{DD} = 15V$  and 2.6% error at  $V_{DD} = 5V$ . This error manifests as nonlinearity in the following curves. For applications where sub-1% error is required, use Equation 7 and Equation 8 for frequencies greater than 10kHz at  $V_{DD} = 5V$ , or greater than 30kHz at  $V_{DD} = 15V$ .

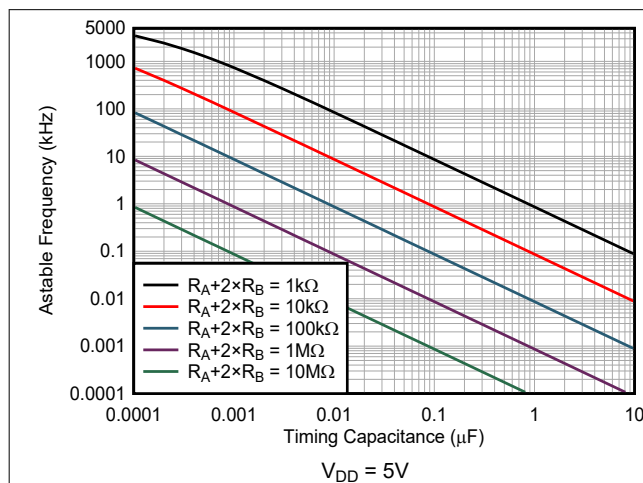

Figure 6-7. Simulated Astable Frequency

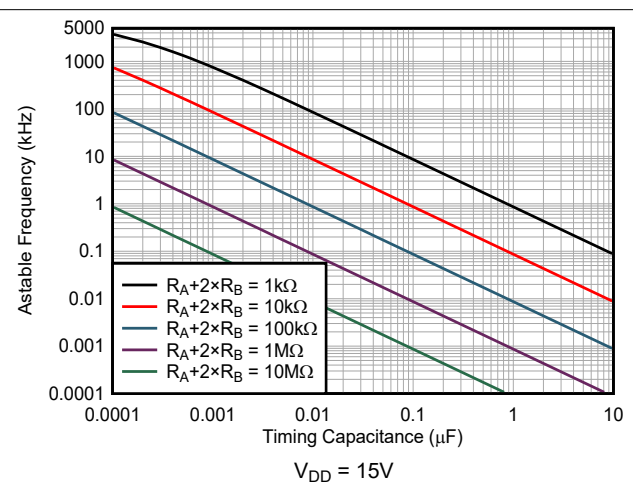

Figure 6-8. Simulated Astable Frequency

### 6.3.3 Power-on Reset

The TLC3555-Q1 includes a power-on reset feature, which holds the output high-impedance until the power-up is complete and the output flip-flop state machine has achieved a valid state. Previous generations of 555 timers lacked this feature, meaning the output state as the power supply ramped was unpredictable. The power-on reset of the TLC3555-Q1 asserts to hold the output in a high-impedance (Hi-Z) state during the ramp event. After the supply voltage has reached the minimum threshold, the power-on reset is released, and the state machine and logic table described in Table 6-1 apply. The RESET pin of the TLC3555-Q1 includes a weak pullup resistance to  $V_{DD}$ , so if the RESET pin is not driven externally, the device exits the reset state after the power-on reset event is complete. The device then enters whatever state is dictated by the values of THRES, TRIG, and CONT.

### 6.3.4 Thermal Shutdown

The TLC3555-Q1 is capable of sourcing and sinking more current than previous CMOS-based 555 timers, such as the [TLC555-Q1](#). To help protect the device from overstress due to self-heating, the TLC3555-Q1 includes a thermal shutdown feature. If the junction temperature rises beyond the shutdown limit, a thermal event is asserted and the output enters a high-impedance state, similar to a power-on reset. The device exits the shutdown state after the junction temperature has sufficiently reduced.

In the event of a very fast, extremely high-current transient, the die temperature can rise too quickly for the thermal shutdown feature to activate in time. If a load at the output is capable of pulling more current than the absolute maximum current rating of the device output, use a resistor in series with the output to limit the maximum current of the device.

### 6.4 Device Functional Modes

[Table 6-1](#) lists the device functional modes. While the TLC3555-Q1 features a weak internal pullup resistor to  $V_{DD}$ , the pullup can be overpowered by coupled noise due to a fast transient signal edge or noisy circuit environment. To improve reliability, use an external pullup resistor to  $V_{DD}$  (if using the RESET functionality), or short the RESET pin directly to  $V_{DD}$  (if the RESET functionality is not used).

**Table 6-1. Function Table**

RESET	TRIGGER VOLTAGE <sup>(1)</sup>	THRESHOLD VOLTAGE <sup>(1)</sup>	OUTPUT	DISCHARGE SWITCH
Low	Irrelevant	Irrelevant	Low	On
High	$< 1/3 V_{CC}$	Irrelevant	High	Off
High	$> 1/3 V_{CC}$	$> 2/3 V_{CC}$	Low	On
High	$> 1/3 V_{CC}$	$< 2/3 V_{CC}$	As previously established	

(1) Voltage levels shown are nominal.

## 7 Application and Implementation

### Note

Information in the following applications sections is not part of the TI component specification, and TI does not warrant its accuracy or completeness. TI's customers are responsible for determining suitability of components for their purposes, as well as validating and testing their design implementation to confirm system functionality.

### 7.1 Application Information

The TLC3555-Q1 timer device uses resistor and capacitor charging delay to provide a programmable time delay or operating frequency. The TLC3555-Q1 can directly drop-in or upgrade most 555 timer applications. The reduced propagation delays and tighter tolerances of the TLC3555-Q1 can lead to slightly discrepant results when directly replacing legacy CMOS timers for high-frequency astable and monostable applications. Assess board-level parasitics before selecting final values for timing components. While the TLC3555-Q1 output sinking current rating is comparable to a bipolar timer, the sourcing limit must be respected and considered when the TLC3555-Q1 is used as a drop-in replacement for a bipolar 555 timer.

The following section presents a simplified discussion of the design process for some unique applications of the TLC3555-Q1.

### 7.2 Typical Applications

#### 7.2.1 Missing-Pulse Detector

The circuit shown in [Figure 7-1](#) can be used to detect a missing pulse or abnormally long spacing between consecutive pulses in a train of pulses. The timing interval of the monostable circuit is triggered continuously by the input pulse train as long as the pulse spacing is less than the timing interval. A longer pulse spacing, missing pulse, or terminated pulse train permits the timing interval to be completed, thereby generating an output pulse, as in [Figure 7-2](#).

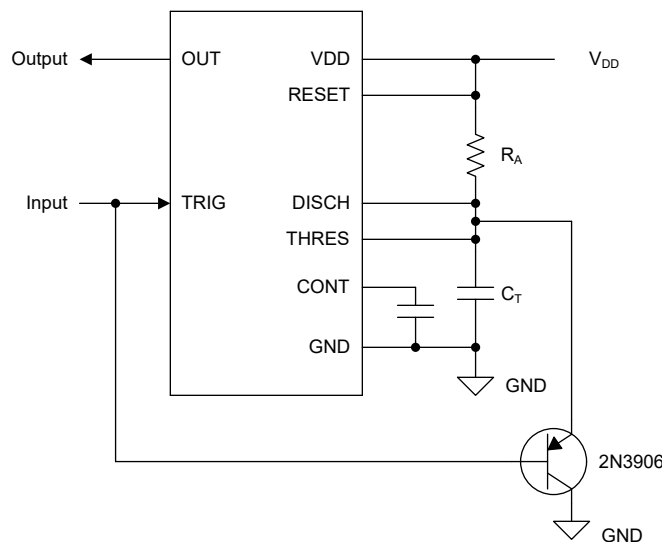

**Figure 7-1. Circuit for Missing-Pulse Detector**

#### 7.2.1.1 Design Requirements

Input fault (missing pulses) must be input high. An input stuck low condition cannot be detected because the timing capacitor ( $C_T$ ) remains discharged.

#### 7.2.1.2 Detailed Design Procedure

Select  $R_A$  and  $C_T$  so that  $R_A \times C_T >$  the maximum normal input high time.

### 7.2.1.3 Application Curve

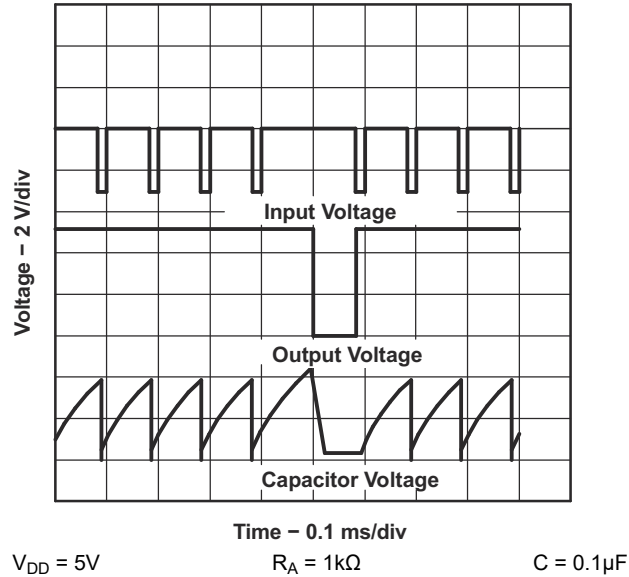

**Figure 7-2. Application Waveform**

### 7.2.2 Pulse-Width Modulation

To modify timer operation, apply an external voltage (or current) to CONT to modulate the internal threshold and trigger voltages. [Figure 7-3](#) shows a circuit for pulse-width modulation. A continuous input pulse train triggers the monostable circuit, and a control signal modulates the threshold voltage. [Figure 7-4](#) shows the resulting duty cycle versus control voltage transfer function. Attempting to run under 10% duty cycle can result in inconsistent output pulses. Attempting to run close to 100% duty cycle results in frequency division by 2, then 3, then 4.

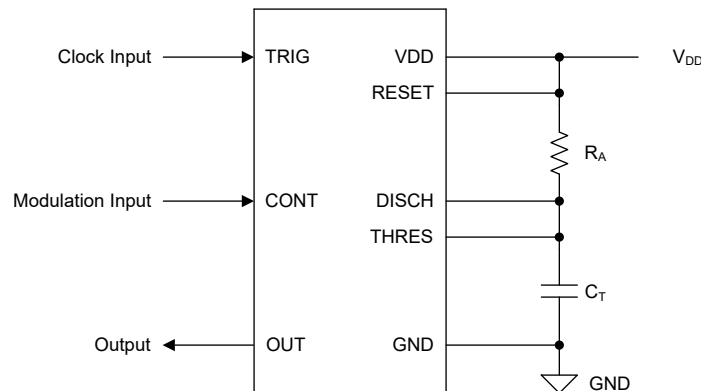

**Figure 7-3. Circuit for Pulse-Width Modulation**

#### 7.2.2.1 Design Requirements

The clock input must have  $V_{OL}$  and  $V_{OH}$  levels that are less than and greater than  $1/3 V_{DD}$ , respectively. Clock input  $V_{OL}$  time must be less than minimum output high time; therefore, a high (positive) duty cycle clock is recommended. The minimum recommended modulation voltage is 1V, as a lower CONT voltage can increase threshold comparator propagation delay and storage time. The application must be tolerant of a nonlinear transfer function; the relationship between modulation input and pulse duration is not linear because the capacitor charge is RC-based with an negative exponential curve.

The modulating signal can be directly or capacitively coupled to CONT. For direct coupling, consider the effects of modulation source voltage and impedance on the bias of the timer.

### 7.2.2.2 Detailed Design Procedure

Select  $R_A$  and  $C_T$  so that  $R_A \times C_T$  is same as or less than the clock input period. Figure 7-4 shows the nonlinear relationship between control voltage and output duty cycle. The duty cycle is a function of the control voltage and clock period relative to the  $R_A \times C_T$  time constant.

### 7.2.2.3 Application Curve

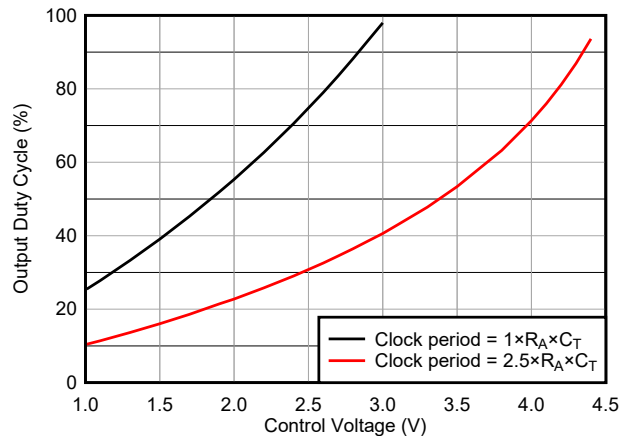

Figure 7-4. Application Waveform

## 7.3 Power Supply Recommendations

The TLC3555-Q1 requires a voltage supply from 1.5V to 18V. Adequate power supply bypassing is required to protect associated circuitry. The minimum recommended decoupling capacitance value is 0.1 $\mu$ F, preferably in parallel with a 1 $\mu$ F electrolytic. Place the bypass capacitors as close as possible to the TLC3555-Q1 and minimize the trace length. During a start-up condition, keep the supply ramp below 1V/ $\mu$ s for proper functionality of the power-on reset feature.

## 7.4 Layout

### 7.4.1 Layout Guidelines

Standard best practices for PCB layout apply to routing the TLC3555-Q1. A 0.1 $\mu$ F decoupling capacitor, preferably in parallel with a 1 $\mu$ F electrolytic bulk decoupling capacitor, must be placed as close as possible to the TLC3555-Q1 supply pins. The capacitor used for the time delay must be placed as close to the discharge pin as possible. A ground plane on the bottom layer can provide better noise immunity and signal integrity.

For circuits operating at or in excess of 100kHz, parasitic capacitance can significantly impact circuit performance and must be carefully controlled. Increase space between adjacent traces where possible, cut out power and ground planes above and below critical traces, and minimize the use of vias on critical traces. Shorter traces have less capacitance due to capacitance per unit length, so minimize component-to-component trace lengths for the timing resistor (or resistors) and timing capacitor. Simulate, calculate, or manually measure board capacitance before selecting a timing capacitor value because the effective timing capacitance  $C_T$  is the sum of the deliberate timing capacitance and parasitic capacitance. Be aware that the timing capacitor value as measured at the frequency of interest can differ from the nominal value; confirm with an LCR meter.



### 7.4.2 Layout Example

Figure 7-5 and Figure 7-6 show the basic layout for monostable and astable applications. Use C0G (NP0) capacitors to improve stability and repeatability.

- $C_T$  – C0G (NP0) ceramic timing capacitance, based on time delay calculations
- $C_1$  – C0G (NP0) ceramic bypass capacitor for control voltage pin,  $0.1\mu\text{F}$
- $C_2$  – C0G (NP0) ceramic bypass capacitor for supply pin,  $0.1\mu\text{F}$
- $C_3$  – electrolytic bypass capacitor for supply pin,  $1\mu\text{F}$
- $R_A$  – timing resistor, based on time delay calculations
- $R_B$  – timing resistor (astable mode), based on time delay calculations

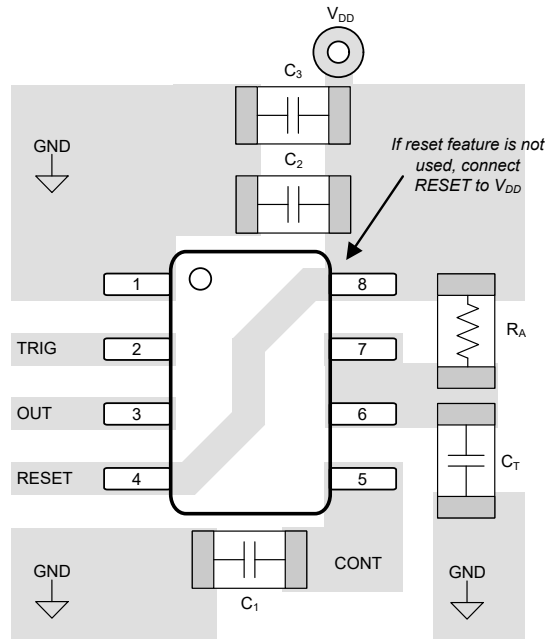

**Figure 7-5. Recommended Layout, Monostable Configuration**

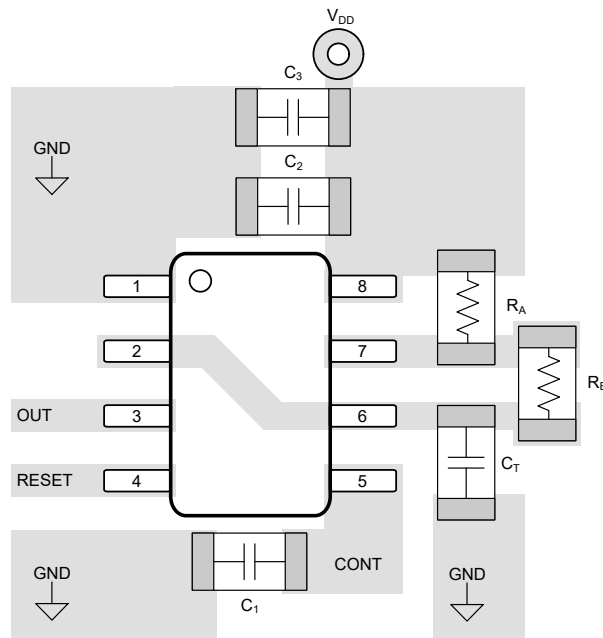

**Figure 7-6. Recommended Layout, Astable Configuration**

## 8 Device and Documentation Support

### 8.1 Documentation Support

#### 8.1.1 Related Documentation

For related documentation see the following:

- Texas Instruments, [TLC3555EVM evaluation module](#)
- Texas Instruments, [TLC555-Q1 Used as a Positive and Negative Charge Pump application note](#)
- Texas Instruments, [EMC Compatible Automotive LED Rear Lamp With Sequential-Turn Animation Reference Design](#)
- Texas Instruments, [Precision PWM Dimming LED Driver Reference Design for Automotive Lighting](#)

### 8.2 Receiving Notification of Documentation Updates

To receive notification of documentation updates, navigate to the device product folder on [ti.com](#). Click on *Notifications* to register and receive a weekly digest of any product information that has changed. For change details, review the revision history included in any revised document.

### 8.3 Support Resources

[TI E2E™ support forums](#) are an engineer's go-to source for fast, verified answers and design help — straight from the experts. Search existing answers or ask your own question to get the quick design help you need.

Linked content is provided "AS IS" by the respective contributors. They do not constitute TI specifications and do not necessarily reflect TI's views; see TI's [Terms of Use](#).

### 8.4 Trademarks

TI E2E™ is a trademark of Texas Instruments.

All trademarks are the property of their respective owners.

### 8.5 Electrostatic Discharge Caution



This integrated circuit can be damaged by ESD. Texas Instruments recommends that all integrated circuits be handled with appropriate precautions. Failure to observe proper handling and installation procedures can cause damage.

ESD damage can range from subtle performance degradation to complete device failure. Precision integrated circuits may be more susceptible to damage because very small parametric changes could cause the device not to meet its published specifications.

### 8.6 Glossary

[TI Glossary](#) This glossary lists and explains terms, acronyms, and definitions.

## 9 Revision History

NOTE: Page numbers for previous revisions may differ from page numbers in the current version.

Changes from Revision * (July 2024) to Revision A (October 2024)	Page
• Changed DDF package status from preview to advance information (preview with samples).....	1
• Added thermal metrics for DDF package in <i>Thermal Information</i> .....	3
• Added <i>TLC3555EVM</i> reference to <i>Related Documentation</i> .....	18

## 10 Mechanical, Packaging, and Orderable Information

The following pages include mechanical, packaging, and orderable information. This information is the most current data available for the designated devices. This data is subject to change without notice and revision of this document. For browser-based versions of this data sheet, refer to the left-hand navigation.

**PACKAGING INFORMATION**

Orderable Device	Status (1)	Package Type	Package Drawing	Pins	Package Qty	Eco Plan (2)	Lead finish/ Ball material (6)	MSL Peak Temp (3)	Op Temp (°C)	Device Marking (4/5)	Samples
TLC3555QDRQ1	ACTIVE	SOIC	D	8	3000	RoHS & Green	NIPDAU	Level-1-260C-UNLIM	-40 to 125	3555Q	Samples
XTL3555QDDFRQ1	ACTIVE	SOT-23-THIN	DDF	8	3000	TBD	Call TI	Call TI	-40 to 125		Samples

(1) The marketing status values are defined as follows:

**ACTIVE:** Product device recommended for new designs.

**LIFEBUY:** TI has announced that the device will be discontinued, and a lifetime-buy period is in effect.

**NRND:** Not recommended for new designs. Device is in production to support existing customers, but TI does not recommend using this part in a new design.

**PREVIEW:** Device has been announced but is not in production. Samples may or may not be available.

**OBsolete:** TI has discontinued the production of the device.

(2) **RoHS:** TI defines "RoHS" to mean semiconductor products that are compliant with the current EU RoHS requirements for all 10 RoHS substances, including the requirement that RoHS substance do not exceed 0.1% by weight in homogeneous materials. Where designed to be soldered at high temperatures, "RoHS" products are suitable for use in specified lead-free processes. TI may reference these types of products as "Pb-Free".

**RoHS Exempt:** TI defines "RoHS Exempt" to mean products that contain lead but are compliant with EU RoHS pursuant to a specific EU RoHS exemption.

**Green:** TI defines "Green" to mean the content of Chlorine (Cl) and Bromine (Br) based flame retardants meet JS709B low halogen requirements of <=1000ppm threshold. Antimony trioxide based flame retardants must also meet the <=1000ppm threshold requirement.

(3) MSL, Peak Temp. - The Moisture Sensitivity Level rating according to the JEDEC industry standard classifications, and peak solder temperature.

(4) There may be additional marking, which relates to the logo, the lot trace code information, or the environmental category on the device.

(5) Multiple Device Markings will be inside parentheses. Only one Device Marking contained in parentheses and separated by a "~" will appear on a device. If a line is indented then it is a continuation of the previous line and the two combined represent the entire Device Marking for that device.

(6) Lead finish/Ball material - Orderable Devices may have multiple material finish options. Finish options are separated by a vertical ruled line. Lead finish/Ball material values may wrap to two lines if the finish value exceeds the maximum column width.

**Important Information and Disclaimer:**The information provided on this page represents TI's knowledge and belief as of the date that it is provided. TI bases its knowledge and belief on information provided by third parties, and makes no representation or warranty as to the accuracy of such information. Efforts are underway to better integrate information from third parties. TI has taken and continues to take reasonable steps to provide representative and accurate information but may not have conducted destructive testing or chemical analysis on incoming materials and chemicals. TI and TI suppliers consider certain information to be proprietary, and thus CAS numbers and other limited information may not be available for release.

In no event shall TI's liability arising out of such information exceed the total purchase price of the TI part(s) at issue in this document sold by TI to Customer on an annual basis.



**TAPE AND REEL INFORMATION**

**QUADRANT ASSIGNMENTS FOR PIN 1 ORIENTATION IN TAPE**

\*All dimensions are nominal

Device	Package Type	Package Drawing	Pins	SPQ	Reel Diameter (mm)	Reel Width W1 (mm)	A0 (mm)	B0 (mm)	K0 (mm)	P1 (mm)	W (mm)	Pin1 Quadrant
TLC3555QDRQ1	SOIC	D	8	3000	330.0	12.5	6.4	5.2	2.1	8.0	12.0	Q1

**TAPE AND REEL BOX DIMENSIONS**

\*All dimensions are nominal

Device	Package Type	Package Drawing	Pins	SPQ	Length (mm)	Width (mm)	Height (mm)
TLC3555QDRQ1	SOIC	D	8	3000	340.5	336.1	25.0

# DDF0008A



# PACKAGE OUTLINE

## SOT-23-THIN - 1.1 mm max height

PLASTIC SMALL OUTLINE

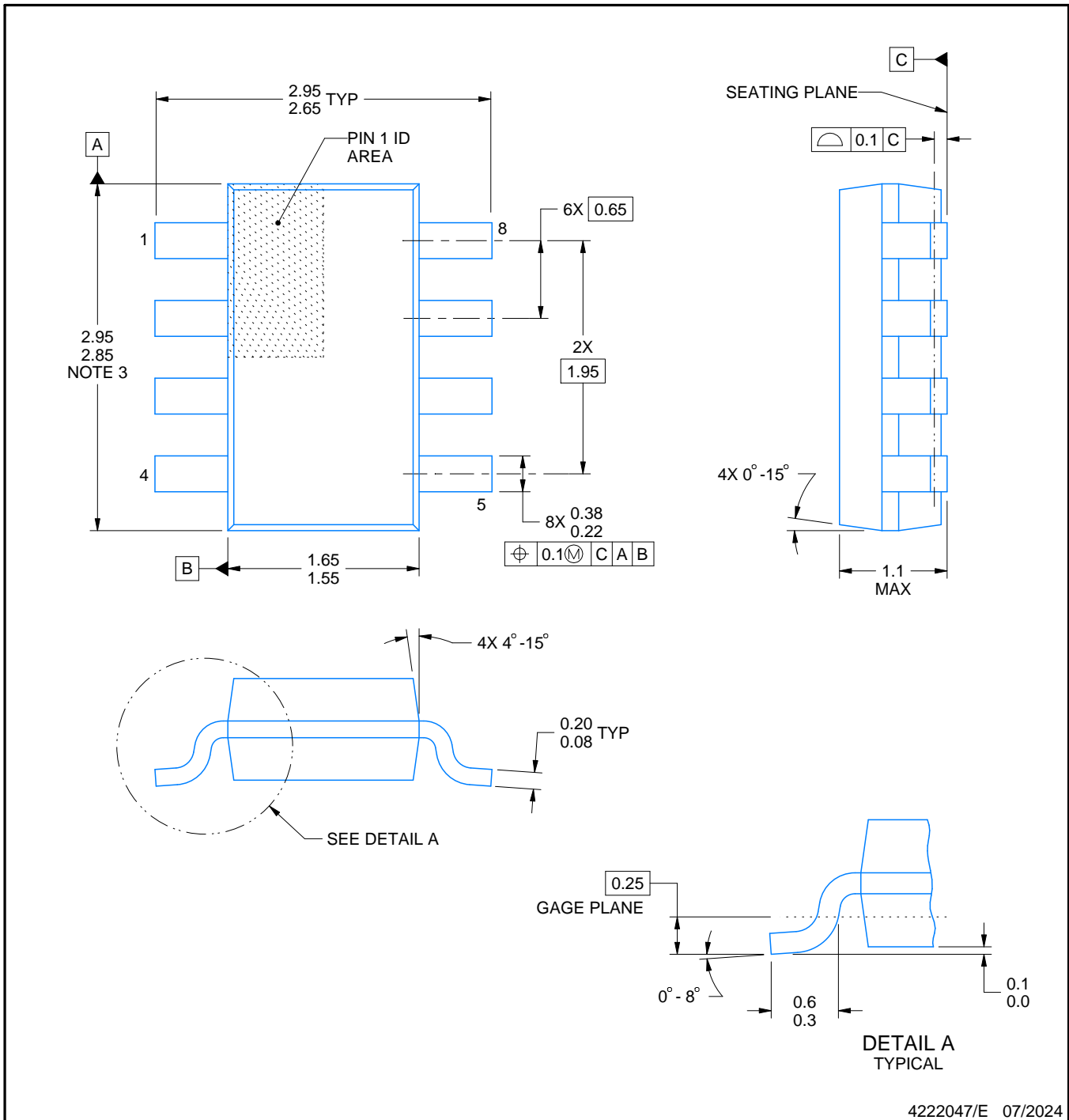

4222047/E 07/2024

### NOTES:

1. All linear dimensions are in millimeters. Any dimensions in parenthesis are for reference only. Dimensioning and tolerancing per ASME Y14.5M.
2. This drawing is subject to change without notice.
3. This dimension does not include mold flash, protrusions, or gate burrs. Mold flash, protrusions, or gate burrs shall not exceed 0.15 mm per side.

# EXAMPLE BOARD LAYOUT

DDF0008A

SOT-23-THIN - 1.1 mm max height

PLASTIC SMALL OUTLINE

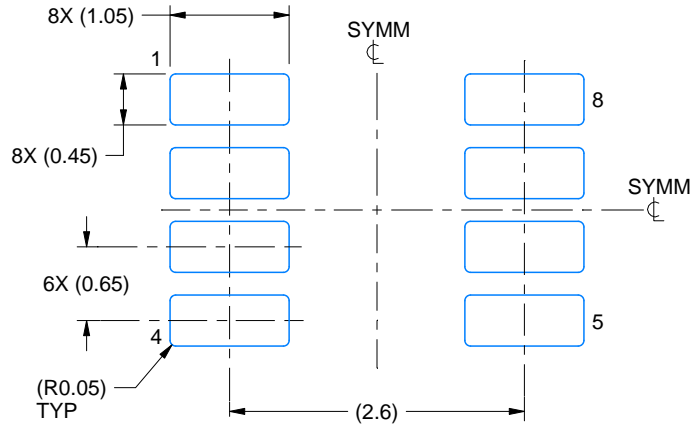

LAND PATTERN EXAMPLE  
EXPOSED METAL SHOWN  
SCALE:15X

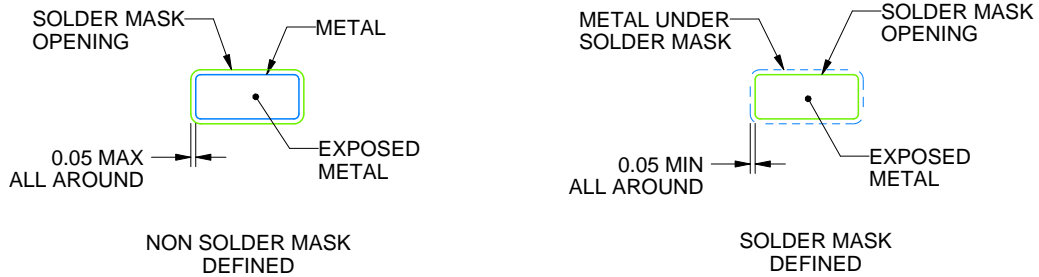

SOLDER MASK DETAILS

4222047/E 07/2024

NOTES: (continued)

- 4. Publication IPC-7351 may have alternate designs.
- 5. Solder mask tolerances between and around signal pads can vary based on board fabrication site.



# EXAMPLE STENCIL DESIGN

DDF0008A

SOT-23-THIN - 1.1 mm max height

PLASTIC SMALL OUTLINE



SOLDER PASTE EXAMPLE  
BASED ON 0.125 mm THICK STENCIL  
SCALE:15X

4222047/E 07/2024

NOTES: (continued)

6. Laser cutting apertures with trapezoidal walls and rounded corners may offer better paste release. IPC-7525 may have alternate design recommendations.
7. Board assembly site may have different recommendations for stencil design.



D0008A

# PACKAGE OUTLINE

SOIC - 1.75 mm max height

SMALL OUTLINE INTEGRATED CIRCUIT



4214825/C 02/2019

### NOTES:

1. Linear dimensions are in inches [millimeters]. Dimensions in parenthesis are for reference only. Controlling dimensions are in inches. Dimensioning and tolerancing per ASME Y14.5M.
2. This drawing is subject to change without notice.
3. This dimension does not include mold flash, protrusions, or gate burrs. Mold flash, protrusions, or gate burrs shall not exceed  $.006$  [0.15] per side.
4. This dimension does not include interlead flash.
5. Reference JEDEC registration MS-012, variation AA.

# EXAMPLE BOARD LAYOUT

D0008A

SOIC - 1.75 mm max height

SMALL OUTLINE INTEGRATED CIRCUIT



LAND PATTERN EXAMPLE  
 EXPOSED METAL SHOWN  
 SCALE:8X



SOLDER MASK DETAILS

4214825/C 02/2019

NOTES: (continued)

- 6. Publication IPC-7351 may have alternate designs.
- 7. Solder mask tolerances between and around signal pads can vary based on board fabrication site.

# EXAMPLE STENCIL DESIGN

D0008A

SOIC - 1.75 mm max height

SMALL OUTLINE INTEGRATED CIRCUIT



SOLDER PASTE EXAMPLE  
BASED ON .005 INCH [0.125 MM] THICK STENCIL  
SCALE:8X

4214825/C 02/2019

NOTES: (continued)

8. Laser cutting apertures with trapezoidal walls and rounded corners may offer better paste release. IPC-7525 may have alternate design recommendations.
9. Board assembly site may have different recommendations for stencil design.

## IMPORTANT NOTICE AND DISCLAIMER

TI PROVIDES TECHNICAL AND RELIABILITY DATA (INCLUDING DATA SHEETS), DESIGN RESOURCES (INCLUDING REFERENCE DESIGNS), APPLICATION OR OTHER DESIGN ADVICE, WEB TOOLS, SAFETY INFORMATION, AND OTHER RESOURCES "AS IS" AND WITH ALL FAULTS, AND DISCLAIMS ALL WARRANTIES, EXPRESS AND IMPLIED, INCLUDING WITHOUT LIMITATION ANY IMPLIED WARRANTIES OF MERCHANTABILITY, FITNESS FOR A PARTICULAR PURPOSE OR NON-INFRINGEMENT OF THIRD PARTY INTELLECTUAL PROPERTY RIGHTS.

These resources are intended for skilled developers designing with TI products. You are solely responsible for (1) selecting the appropriate TI products for your application, (2) designing, validating and testing your application, and (3) ensuring your application meets applicable standards, and any other safety, security, regulatory or other requirements.

These resources are subject to change without notice. TI grants you permission to use these resources only for development of an application that uses the TI products described in the resource. Other reproduction and display of these resources is prohibited. No license is granted to any other TI intellectual property right or to any third party intellectual property right. TI disclaims responsibility for, and you will fully indemnify TI and its representatives against, any claims, damages, costs, losses, and liabilities arising out of your use of these resources.

TI's products are provided subject to [TI's Terms of Sale](#) or other applicable terms available either on [ti.com](https://www.ti.com) or provided in conjunction with such TI products. TI's provision of these resources does not expand or otherwise alter TI's applicable warranties or warranty disclaimers for TI products.

TI objects to and rejects any additional or different terms you may have proposed.

Mailing Address: Texas Instruments, Post Office Box 655303, Dallas, Texas 75265  
Copyright © 2024, Texas Instruments Incorporated