

TPS92643-Q1 Automotive 3-A Synchronous Buck LED Driver

1 Features

- AEC-Q100 qualified for automotive applications
 - Grade 1: -40°C to 125°C ambient operating temperature
 - Device HBM classification level H1C
 - Device CDM classification level C5
- Input voltage range: 5.5 V to 36 V
 - Operation down to 5.15 V after start-up
- Up to 3-A continuous with 4% accuracy
- Adaptive on-time current control
 - Low offset high-side current sense amplifier
 - Stable with any combination of ceramic, and aluminum capacitors
- Programmable switching frequency from 100 kHz to 2.2 MHz
- Advanced dimming operation
 - 1000:1 precision PWM dimming
 - 15:1 precision analog dimming
 - 1.4-kHz internal analog input to PWM duty cycle translation
- Cycle-by-cycle switch overcurrent protection
- Open-drain fault indicator output
 - LED short circuit, open circuit and cable harness fault indication
- Thermal shutdown protection

2 Applications

- Headlight
- Front fog light LED driver module

3 Description

The TPS92643-Q1 is a monolithic, synchronous Buck LED driver with a wide 5.5-V to 36-V operating input voltage range and 40-V tolerance that supports load dump for duration of 400 ms. The TPS92643-Q1 implements an adaptive on-time average current mode control based on inductor valley current detection. The adaptive on-time control provides near constant switching frequency that can be set between 100 kHz and 2.2 MHz. Inductor current sensing and closed-loop feedback enables better than ±4% accuracy over wide input, output and ambient temperature.

The high-performance LED driver can independently modulate LED current using both analog or PWM dimming techniques. Linear analog dimming range with over 15:1 range is obtained by setting the IADJ voltage. PWM dimming of LED current is achieved by directly modulating the UDIM input pin with desired duty cycle or setting the analog voltage at APWM

to enable internal analog-to-PWM conversion. The internal PWM generator translates the external analog voltage by comparing it to an internal 1.4-kHz ramp signal.

The TPS92643-Q1 incorporates advanced diagnostic and fault protection featuring: cycle-by-cycle switch current limit, bootstrap undervoltage, LED open, LED short and thermal shutdown.

The TPS92643-Q1 is available in a 6.6-mm × 5.1-mm thermally-enhanced 16-pin HTSSOP package with 0.65-mm lead pitch.

Device Information

PART NUMBER	PACKAGE ⁽¹⁾	BODY SIZE (NOM)
TPS92643-Q1	HTSSOP (16)	6.60 mm × 5.10 mm

(1) For all available packages, see the orderable addendum at the end of the data sheet.

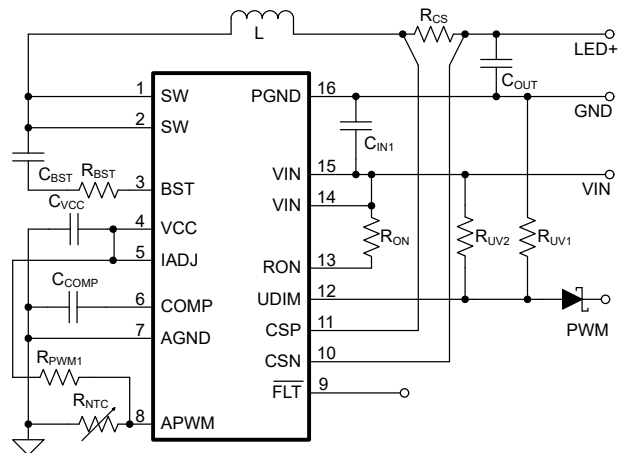

Typical Buck LED Driver Application Schematic

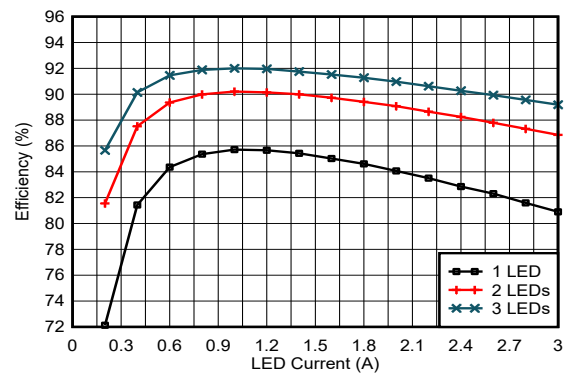

Typical Efficiency

Table of Contents

1 Features	1	7.4 Device Functional Modes.....	21
2 Applications	1	8 Application and Implementation	22
3 Description	1	8.1 Application Information.....	22
4 Revision History	2	8.2 Typical Application.....	26
5 Pin Configuration and Functions	3	9 Power Supply Recommendations	30
6 Specifications	4	10 Layout	31
6.1 Absolute Maximum Ratings.....	4	10.1 Layout Guidelines.....	31
6.2 ESD Ratings.....	4	10.2 Layout Example.....	32
6.3 Recommended Operating Conditions.....	4	11 Device and Documentation Support	33
6.4 Thermal Information.....	5	11.1 Receiving Notification of Documentation Updates..	33
6.5 Electrical Characteristics.....	5	11.2 Support Resources.....	33
6.6 Typical Characteristics.....	8	11.3 Trademarks.....	33
7 Detailed Description	10	11.4 Electrostatic Discharge Caution.....	33
7.1 Overview.....	10	11.5 Glossary.....	33
7.2 Functional Block Diagram.....	11	12 Mechanical, Packaging, and Orderable Information	33
7.3 Feature Description.....	12		

4 Revision History

DATE	REVISION	NOTES
May 2022	*	Initial release.

5 Pin Configuration and Functions

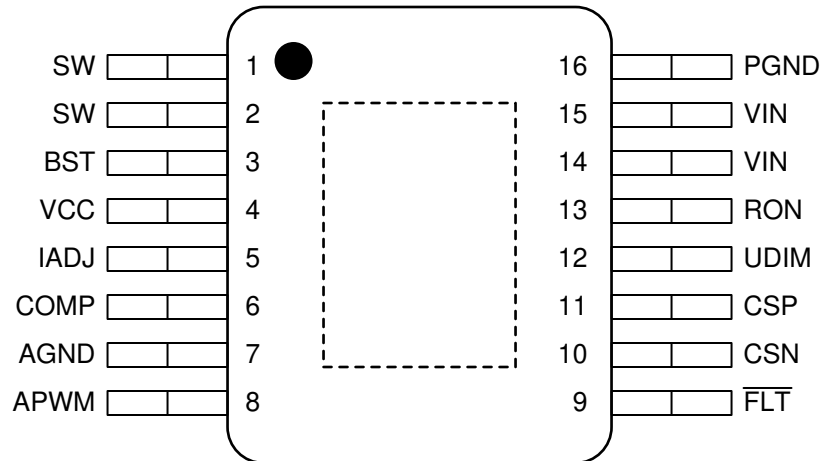

Figure 5-1. PWP Package, 16-Pin HTSSOP with PowerPAD, Top View

Table 5-1. Pin Functions

PIN		I/O	DESCRIPTION
NO.	NAME		
7	AGND	—	Analog ground. Return for the internal voltage reference and analog circuit. Connect to circuit ground, GND, to complete return path.
3	BST	I	Supply input for high-side MOSFET gate drive circuit. Connect a ceramic capacitor between BST and SW pins. An internal diode is connected between VCC and BST pins.
6	COMP	O	Output of internal transconductance error amplifier. Connect an integral compensation network to ensure stability.
10	CSN	I	Negative input (–) of internal rail-to-rail transconductance error amplifier. Connect directly to the negative node of the LED current sense resistor, R_{CS} .
11	CSP	I	Positive input (+) of internal rail-to-rail transconductance error amplifier. Connect directly to the positive node of the LED current sense resistor, R_{CS} .
9	FLT	O	Open-drain fault indicator. Connect to VCC with a resistor to create an active low fault signal output.
5	IADJ	I	Analog adjust input. Input below 100 mV disables the output. The analog input can be varied between 140 mV to 2.4 V to set current reference from 10 mV to 175 mV. Connect a 0.1- μ F capacitor from pin to AGND.
16	PGND	—	Ground returns for low-side MOSFETs
8	APWM	I	External analog to PWM dimming command. The external analog dimming command between 1 V and 2.45 V is compared to the internal 1.5-kHz triangle waveform to set LED current duty cycle between 0% and 100%.
13	RON	I	On-time programming pin. Connect a resistor to VIN based on the desired pseudo-fixed switching frequency.
1,2	SW	I	Switching output of the regulator. Internally connected to both power MOSFETs. Connect to the power inductor.
12	UDIM	I	Undervoltage lockout and external PWM dimming input. Connect to VIN through a resistor divider to implement input undervoltage protection. Diode couple external PWM signal to enable dimming. Do not float.
4	VCC	O	VCC bias supply pin. Locally decouple to AGND using a 2.2- μ F to 4.7- μ F ceramic capacitor located close to the controller.
14,15	VIN	I	Power input and connection to high-side MOSFET drain node. Connect to the power supply and bypass capacitors C_{IN} . The path from the VIN pin to the high frequency bypass capacitor and PGND must be as short as possible.
PowerPAD		—	The AGND and PGND pin must be connected to the exposed PowerPAD for proper operation. This PowerPAD must be connected to PCB ground plane using multiple vias for good thermal performance.

6 Specifications

6.1 Absolute Maximum Ratings

over operating free-air temperature range (unless otherwise noted)⁽¹⁾

		MIN	MAX	UNIT
Input Voltage	V _{IN}	-0.3	36	V
	V _{IN} (< 400 ms)		40	V
Bias supply voltage, VCC	V _{VCC}	-0.3	5.5	V
Boot voltage, BST	BST to SW	-0.3	5.5	V
	BST to GND	-0.3	41.5	V
Switch node voltage	V _{SW} to GND	-0.5	36	V
	V _{SW} to GND (< 400 ms)	-0.5	40	V
	V _{SW} to GND (< 10 ns)	-3.5	40	V
Inputs	CSP, CSN	-0.5	36	V
	RON	-0.1	36	V
	I _{RON}		500	μA
	V _(CSP-CSN)	-0.3	0.3	mV
	UDIM to GND	-0.3	V _{VIN}	V
	IADJ	-0.1	5.5	V
	COMP, APWM	-0.3	5.5	V
Outputs	FLT	-0.3	20	V
Ground	PGND to AGND	-0.5	0.5	V
	PGND to AGND (< 10 ns)	-3.5	3.5	V
T _J	Junction temperature	-40	150	°C
T _{stg}	Storage temperature	-40	150	°C

- (1) Operation outside the *Absolute Maximum Ratings* may cause permanent device damage. *Absolute Maximum Ratings* do not imply functional operation of the device at these or any other conditions beyond those listed under Recommended Operating Conditions. If used outside the *Recommended Operating Conditions* but within the *Absolute Maximum Ratings*, the device may not be fully functional, and this may affect device reliability, functionality, performance, and shorten the device lifetime.

6.2 ESD Ratings

			VALUE	UNIT	
V _(ESD)	Electrostatic discharge	Human body model (HBM), per AEC Q100-002 ⁽¹⁾	±2000	V	
		Charged device model (CDM), per AEC Q100-011	Corner pins (SW, APWM, FLT and PGND)		±750
			Other pins		±500

- (1) AEC Q100-002 indicates that HBM stressing shall be in accordance with the ANSI/ESDA/JEDEC JS-001 specification.

6.3 Recommended Operating Conditions

over operating free-air temperature range (unless otherwise noted)

		MIN	NOM	MAX	UNIT
V _{VIN}	Input Voltage	5.5		36	V
V _(CSP-CSN)	Sensed inductor current ripple voltage	8			mV
dV _{CSP} /dt	CSP slew-rate			10	V/μs
I _{LED}	LED Current (Continuous)			3	A
V _{APWM}	Analog PWM Input	-0.3		3	
V _{UDIM}	Digital PWM Input	-0.3		V _{VIN}	

6.3 Recommended Operating Conditions (continued)

over operating free-air temperature range (unless otherwise noted)

		MIN	NOM	MAX	UNIT
FLT	Fault Output	-0.3		18	
f _{SW}	Switching Frequency	400		2200	kHz
T _A	Ambient temperature	-40		125	°C
T _J	Junction temperature	-40		150	°C

6.4 Thermal Information

THERMAL METRIC ⁽¹⁾		DEVICE	UNIT
		PKG (HTSSOP)	
		PINS	
R _{θJA}	Junction-to-ambient thermal resistance	38.9	°C/W
R _{θJC(top)}	Junction-to-case (top) thermal resistance	24.3	°C/W
R _{θJB}	Junction-to-board thermal resistance	19.9	°C/W
Ψ _{JT}	Junction-to-top characterization parameter	0.7	°C/W
Ψ _{JB}	Junction-to-board characterization parameter	19.7	°C/W
R _{θJC(bot)}	Junction-to-case (bottom) thermal resistance	1.7	°C/W

(1) For more information about traditional and new thermal metrics, see the [Semiconductor and IC Package Thermal Metrics](#) application report.

6.5 Electrical Characteristics

-40°C < T_J < 150°C, V_{IN} = 14V, V_{UDIM} = 5V, V_{IADJ} = 2.1V, C_{VCC} = 2.2μF, C_{BST} = 1nF, C_{COMP} = 1nF, R_{CS} = 100mΩ, R_{ON} = 401kΩ, V_{APWM} = 5V, f_{SW} = 200 kHz

PARAMETER		TEST CONDITIONS	MIN	TYP	MAX	UNIT
INPUT VOLTAGE (VIN)						
V _{DO}	LDO dropout voltage	I _{VCC} = 20 mA, V _{VIN} = 5 V		315		mV
I _{SW}	Input switching current			10	17.6	mA
I _{OP}	Input operating current	Not switching, V _{IADJ} = V _{VCC}		2	4	mA
BIAS SUPPLY (VCC)						
V _{CC(UVLO-RISE)}	Rising threshold	VCC rising threshold, V _{VIN} = 8 V		4.40	4.58	V
V _{CC(UVLO-FALL)}	Falling threshold	VCC falling threshold, V _{VIN} = 8 V	3.9	4.2		V
V _{CC(UVLO-HYS)}		Hysteresis		200		mV
V _{CC(REG)}	Regulation voltage	No Load	4.75	5.00	5.25	V
I _{CC(LIMIT)}	Supply current Limit	V _{VCC} = 0 V	45	56	76	mA
HIGH-SIDE FET (SW, BOOT)						
R _{DS(ON-HS)}	High-side MOSFET on resistance	I _{LED} = 100 mA		65	130	mΩ
V _{BST(UV)}	Bootstrap gate drive UVLO	V _(BST-SW) rising	2.95	3.2	3.47	V
V _{BST(HYS)}	Bootstrap gate drive UVLO hysteresis	Hysteresis	175	207	240	mV
I _{Q(BST)}	Bootstrap pin quiescent current	V _{SW} = 0V, V _{UDIM} = 0 V, V _{BOOT} = 5 V	197	265	325	μA
LOW-SIDE FET (SW)						
R _{DS(ON-LS)}	Low-side MOSFET on resistance	I _{LED} = 100 mA		67	130	mΩ
HIGH SIDE FET CURRENT LIMIT						
I _{LIM(HS)}	High-side current limit threshold		3.75	4.80	5.85	A
t _(HS-BLANK)	High-side current sense blanking period		35	60	80	ns
LOW SIDE FET CURRENT LIMIT						
I _{SINK(LS)}	Sinking current limit		2.0	3.2	4.3	A

6.5 Electrical Characteristics (continued)

–40°C < T_J < 150°C, V_{IN} = 14V, V_{UDIM} = 5V, V_{IADJ} = 2.1V, C_{VCC} = 2.2μF, C_{BST} = 1nF, C_{COMP} = 1nF, R_{CS} = 100mΩ, R_{ON} = 401kΩ, V_{APWM} = 5V, f_{SW} = 200 kHz

PARAMETER		TEST CONDITIONS	MIN	TYP	MAX	UNIT
t _{BLANK}	Blanking time			71		ns
ERROR AMPLIFIER (CSP, CSN, COMP)						
V _(CSP-CSN)	Current sense threshold	V _{IADJ} = V _{CC} , V _{CSP} = 3 V, I _{COMP} = 0 V	168	175	182	mV
		V _{IADJ} = 2.1 V, V _{CSP} = 3 V, I _{COMP} = 0 V		150		mV
g _M	Transconductance			450		μA/V
I _{COMP(SRC)}	COMP current source capacity	V _{IADJ} = 2.5 V, V _(CSP-CSN) = 0 V		200		μA
I _{COMP(SINK)}	COMP current sink capacity	V _{IADJ} = 150 mV, V _(CSP-CSN) = 300 mV		140		μA
V _{COMP(RISE)}	COMP startup threshold	Rising		2.45		V
V _{COMP(HYS)}	COMP startup comparator hysteresis			440		mV
EA _(BW)	Bandwidth	Unity gain bandwidth		3		MHz
I _{COMP(LKG)}	Comp leakage current	V _{UDIM} = 0 V		2.5		nA
V _{COMP(RST)}	COMP pin reset voltage	V _{VCC} dropping from 5 V to 0 V		100		mV
R _{COMP(DCH)}	COMP discharge FET resistance			230		Ω
V _{COMP(OV)}	COMP overvoltage protection threshold		2.9	3.2		V
V _{COMP(OV-HYS)}	COMP overvoltage protection hysteresis			60		mV
V _{CSP(SHORT)}	Output short circuit detection threshold	Falling		1.5		V
		Rising		1.6		V
ANALOG ADJUST INPUT (IADJ)						
V _{IADJ(CLAMP)}	IADJ internal clamp voltage			2.45		V
V _{IADJ(DIS)}	Disable threshold voltage	Rising		133		mV
V _{IADJ(DIS)}	Disable threshold voltage	Falling		100		mV
VALLEY CURRENT COMPARATOR						
g _{M(LV)}	Level shift amplifier transconductance			50		μA/V
t _{DEL}	V _(CSP-CSN) falling to gate rising delay			65	80	ns
ON-TIME GENERATOR (RON)						
t _{ON(MIN)}	Minimum on-time		81	96	111	ns
t _{ON}	Programmed on-time	V _{VIN} = 14 V, V _{CSP} = 5 V, R _{ON} = 35 kΩ		150		ns
		V _{VIN} = 10 V, V _{CSP} = 8 V, R _{ON} = 35 kΩ		336		ns
		V _{VIN} = 14 V, V _{CSP} = 3 V, R _{ON} = 400 kΩ		0.95		μs
		V _{VIN} = 10 V, V _{CSP} = 8 V, R _{ON} = 400 kΩ		3.55		μs
MINIMUM OFF-TIME						
t _{OFF(MIN)}	Minimum off-time	V _(CSP-CSN) = 0 V, V _{COMP} = 2.5 V	76	91	106	ns
PWM DIMMING and PROGRAMMABLE UVLO INPUT (UDIM)						
I _{UDIM(DO)}	UDIM source current (UVLO hysteresis)	V _{UDIM} > 2.45 V	6.5	10	13	μA
V _{UDIM(DO,RISE)}	Dropout detection rising threshold	V _{UDIM} rising		2.44	2.54	V
V _{UDIM(DO,FALL)}	Dropout detection falling threshold	V _{UDIM} falling	2.24	2.34		V
V _{UDIM(EN,RISE)}	Undervoltage lockout rising threshold	V _{UDIM} rising		1.22	1.27	V
V _{UDIM(EN,FALL)}	Undervoltage lockout falling threshold	V _{UDIM} falling	1.075	1.120		V
t _{UDIM(RISE)}	UDIM to SW pin rising delay			245		ns
t _{UDIM(FALL)}	UDIM pin SW pin falling delay			105		ns
ANALOG TO PWM GENERATOR (APWM)						
f _{RAMP}	Internal ramp generator frequency	V _{UDIM} = 5 V	1.0	1.5	1.9	kHz
V _{RAMP(HIGH)}	Internal ramp high threshold	V _{UDIM} = 5 V		2.45	2.60	V

6.5 Electrical Characteristics (continued)

–40°C < T_J < 150°C, V_{IN} = 14V, V_{UDIM} = 5V, V_{IADJ} = 2.1V, C_{VCC} = 2.2μF, C_{BST} = 1nF, C_{COMP} = 1nF, R_{CS} = 100mΩ, R_{ON} = 401kΩ, V_{APWM} = 5V, f_{SW} = 200 kHz

PARAMETER		TEST CONDITIONS	MIN	TYP	MAX	UNIT
V _{RAMP(LOW)}	Internal ramp low threshold	V _{UDIM} = 5 V	0.95	1.00		V
V _{RAMP(CLAMP)}	Internal ramp clamp	V _{UDIM} = 0 V		1		V
t _{APWM(RISE)}	APWM to SW pin rising delay			200		ns
t _{APWM(FALL)}	APWM to SW pin falling delay			80		ns
V _{APWM(HYS)}	Analog to PWM comparator hysteresis			5		mV
FAULT INDICATION (nFLT)						
R _(FLT)	Fault pin pull-down resistance	I _{FLT} = 20 mA		2.5	7	Ω
T _{OC}	Hiccup retry delay time			5.5		ms
T _{UC(BLANK)}	Undercurrent reporting blanking period			20		μs
I _{FLT(LKG)}	Fault pin leakage current				100	nA
THERMAL SHUTDOWN						
T _{SD}	Thermal shutdown threshold			175		°C
T _{SD(HYS)}	Thermal shutdown hysteresis			15		°C

6.6 Typical Characteristics

$-40^{\circ}\text{C} < T_J < 150^{\circ}\text{C}$, $V_{IN} = 14\text{ V}$, $V_{UDIM} = 5\text{ V}$, $V_{IADJ} = 2.1\text{ V}$, $C_{VCC} = 2.2\ \mu\text{F}$, $C_{BST} = 1\text{ nF}$, $C_{COMP} = 1\text{ nF}$, $R_{CS} = 100\text{ m}\Omega$, $R_{ON} = 401\text{ k}\Omega$, $V_{APWM} = 5\text{ V}$, $f_{SW} = 200\text{ kHz}$

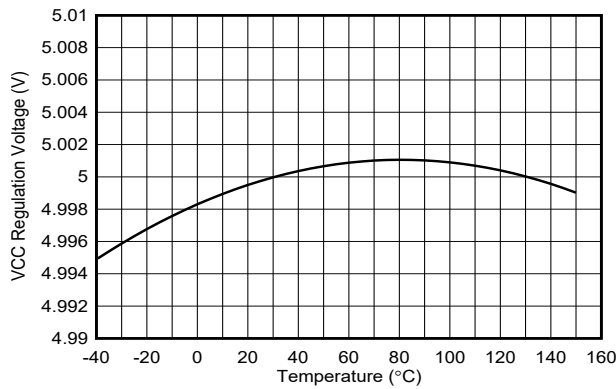

Figure 6-1. VCC Regulation Voltage vs Temperature

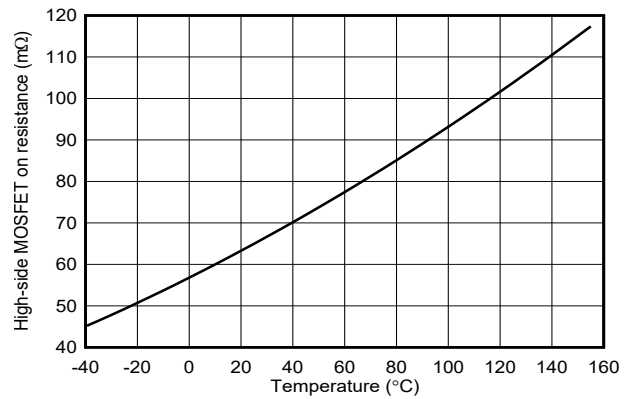

Figure 6-2. High-Side MOSFET On Resistance vs Temperature

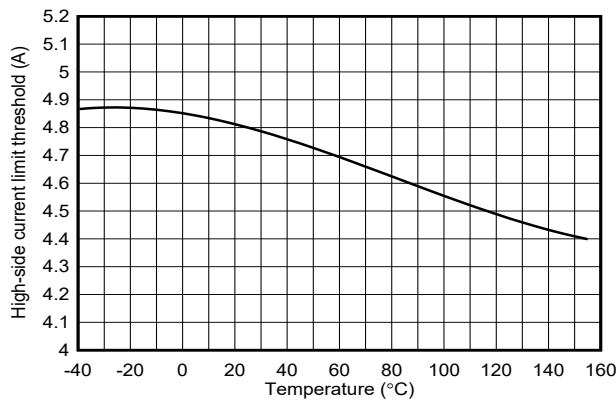

Figure 6-3. High-Side Current Limit Threshold vs Temperature

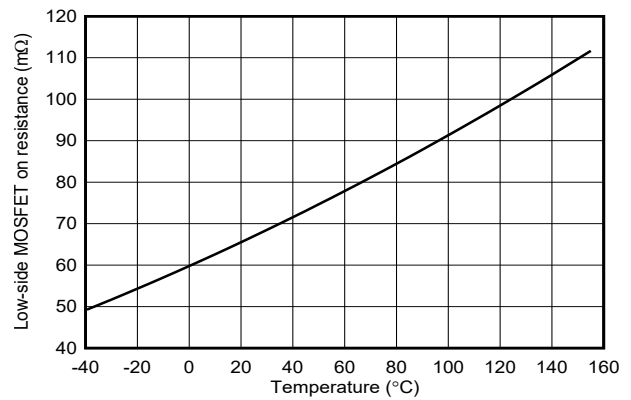

Figure 6-4. Low-Side MOSFET On Resistance vs Temperature

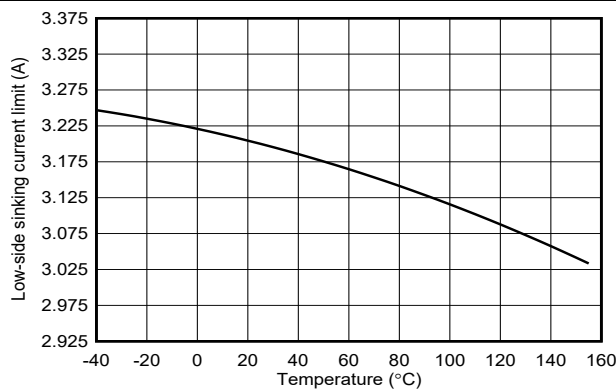

Figure 6-5. Low-Side Sinking Current Limit vs Temperature

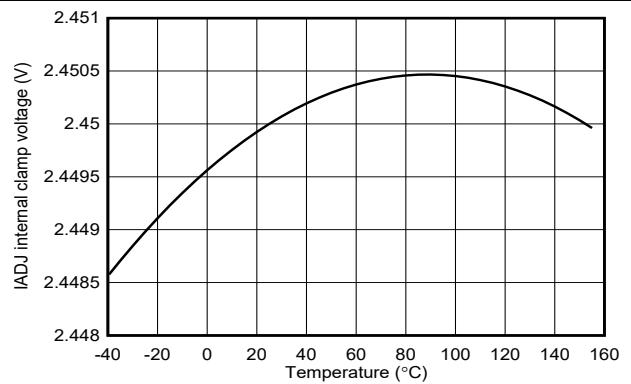

Figure 6-6. IADJ Internal Clamp Voltage vs Temperature

6.6 Typical Characteristics (continued)

$-40^{\circ}\text{C} < T_J < 150^{\circ}\text{C}$, $V_{IN} = 14\text{ V}$, $V_{UDIM} = 5\text{ V}$, $V_{IADJ} = 2.1\text{ V}$, $C_{VCC} = 2.2\text{ }\mu\text{F}$, $C_{BST} = 1\text{ nF}$, $C_{COMP} = 1\text{ nF}$, $R_{CS} = 100\text{ m}\Omega$, $R_{ON} = 401\text{ k}\Omega$, $V_{APWM} = 5\text{ V}$, $f_{SW} = 200\text{ kHz}$

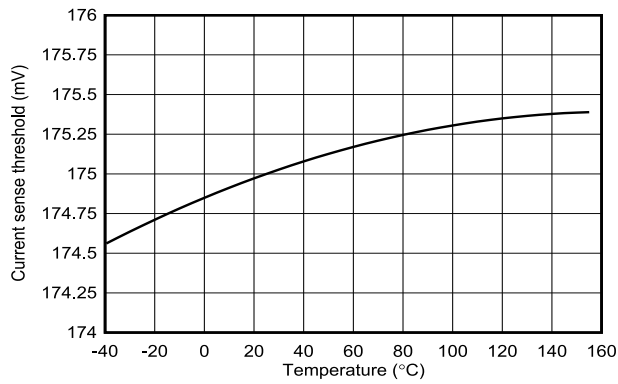

Figure 6-7. $V_{(CSP-CSN)}$ Sense Threshold vs Temperature

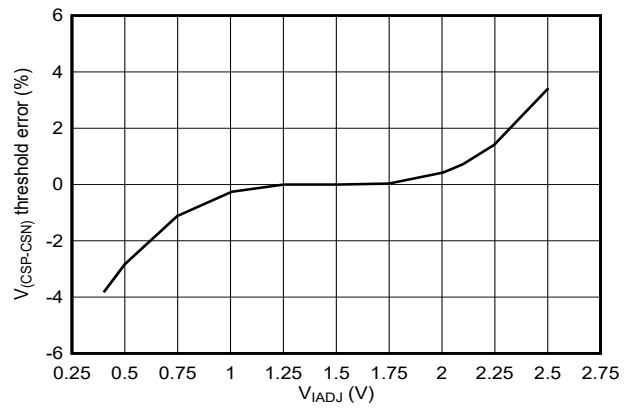

Figure 6-8. $V_{(CSP-CSN)}$ Sense Error vs IADJ Setpoint

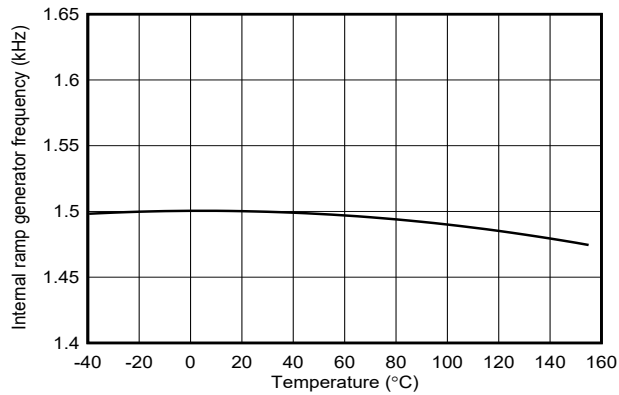

Figure 6-9. Internal Ramp Generator Frequency vs Temperature

7 Detailed Description

7.1 Overview

The TPS92643-Q1 is a wide input, synchronous buck LED driver. The device can deliver up to 3 A of continuous current and power a single string of one to 10 series-connected LEDs. The device implements an adaptive on-time current regulation control technique to achieve fast transient response. This architecture uses a comparator and a one-shot on-timer that varies inversely with input and output voltage to maintain a near-constant frequency. The integrated low offset rail-to-rail error amplifier enables closed-loop regulation of LED current and ensures better than 4% accuracy over a wide input, output, and temperature range. The LED current reference is set by the IADJ pin and is programmed by a voltage divider to achieve over a 15:1 linear analog dimming range. The high impedance IADJ input simplifies LED current binning and thermal protection.

The TPS92643-Q1 device incorporates an internal ramp generator to control LED current through pulse width modulation (PWM) dimming. The PWM duty cycle can be varied from 0% to 100% by modulating the analog voltage on APWM from $V_{RAMP(LOW)}$ to $V_{RAMP(HIGH)}$. The PWM dimming frequency is internally set to typical value of 1.5 kHz. In addition, an external PWM input can control current by driving UDIM input. When both UDIM and APWM inputs are present, the internal PWM control command is derived by ANDing the two pulse width modulated signals. The APWM input can be tied to VCC to enable only external PWM control. Alternatively, APWM input can be biased using NTC to scale average LED current and enable temperature foldback protection of LEDs. This device optimizes the inductor current response and is capable of achieving over a 1000:1 PWM dimming ratio.

The device incorporates enhanced programmable fault features, including the following:

- Cycle-by-cycle switch overcurrent limit
- Input undervoltage protection
- Boot undervoltage protection
- Comp overvoltage warning
- Thermal warning
- LED short-circuit indication

In addition, thermal shutdown (TSD) protection is implemented to limit the junction temperature at 175°C (typical).

7.2 Functional Block Diagram

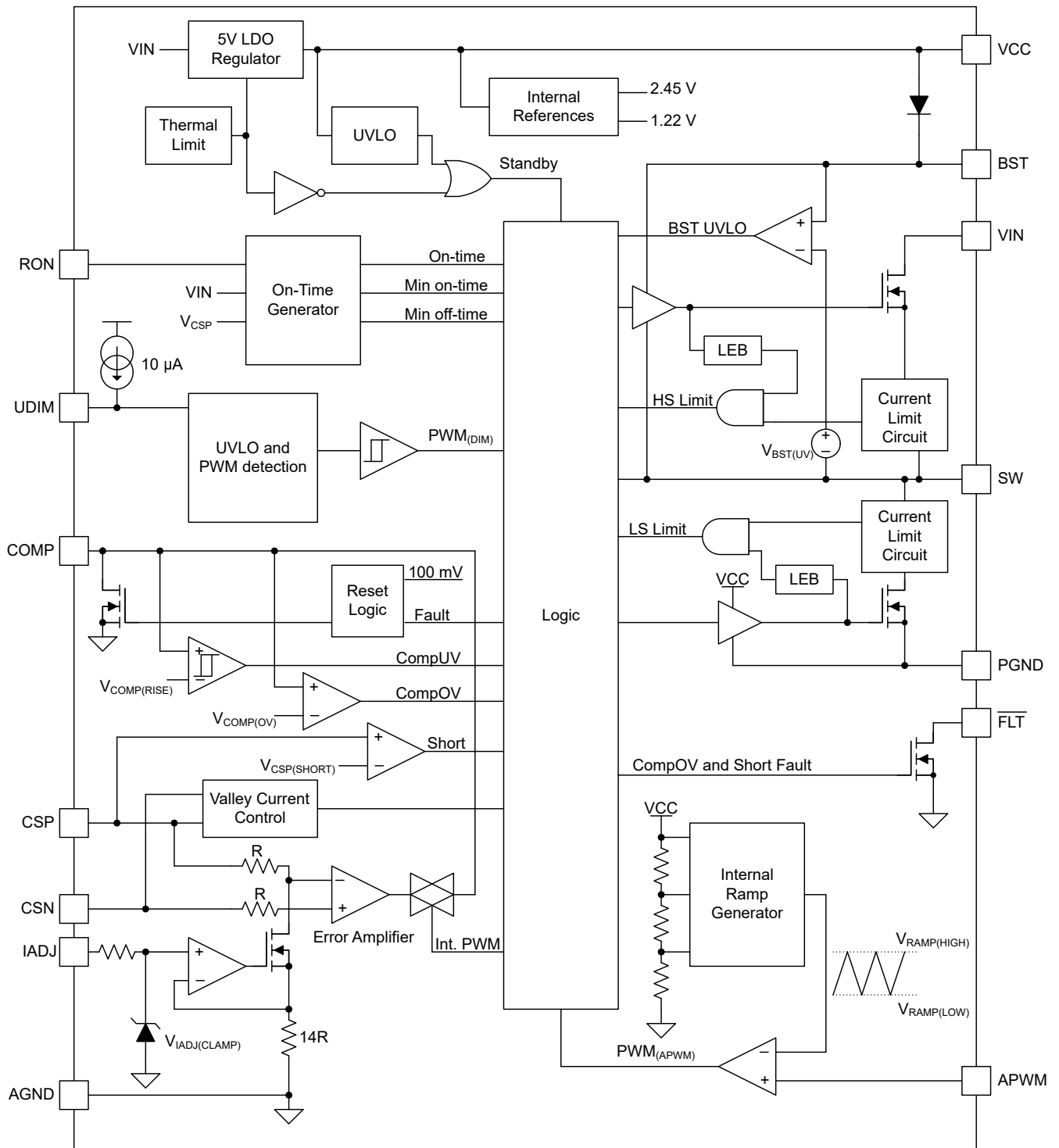

7.3 Feature Description

7.3.1 Internal Regulator

The TPS92643-Q1 incorporates a 36-V input voltage rated linear regulator to generate the 5-V (typical) V_{CC} bias supply and other internal reference voltages. The device monitors the V_{CC} output to implement UVLO protection. Operation is enabled when V_{CC} exceeds the $V_{CC(UVLO)}$ rising threshold and is disabled when V_{CC} drops below $V_{CC(UVLO)}$ falling threshold. The comparator provides 200 mV of hysteresis to avoid chatter during transitions. The V_{CC} UVLO thresholds are internally fixed and cannot be adjusted. An internal current limit circuit is implemented to protect the device during VCC pin short-circuit conditions. The V_{CC} supply powers the internal circuitry, the low-side gate driver and the bootstrap supply for high-side gate driver. Place a bypass capacitor in the range of 4.7 μ F to 10 μ F close to the device, across the VCC pin to AGND. The capacitor from VCC must be five times larger than the bootstrap capacitor, C_{BST} to support proper operation. The regulator operates in dropout when input voltage, V_{IN} falls below 5 V, forcing V_{CC} to be lower than V_{IN} by V_{DO} for a 20-mA supply current. The V_{CC} is a regulated output of the internal regulator and is not recommended to be driven from an external power supply.

7.3.2 Buck Converter Switching Operation

The following operating description of the TPS92643-Q1 refers to the [Functional Block Diagram](#) and the waveforms in [Figure 7-1](#). The main control loop of the TPS92643-Q1 is based on an adaptive on-time pulse width modulation (PWM) technique that combines a constant on-time control with an inductor valley current sense circuit for pseudo-fixed frequency operation. This proprietary control technique enables closed-loop regulation of LED current and fast dynamic response necessary to meet the requirements for dimming animation and fault protection.

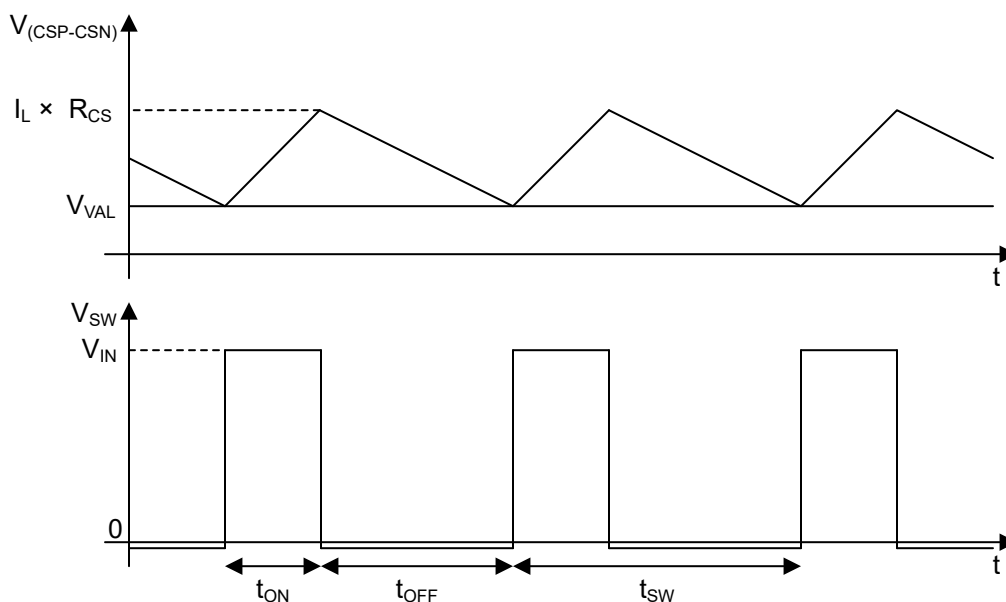

Figure 7-1. Adaptive On-Time Buck Converter Waveforms

In steady state, the high-side MOSFET is turned on at the beginning of each cycle. The on-time duration of this MOSFET is controlled by an internal one-shot timer and the high-side MOSFET is turned off after the timer expires. The one-shot timer duration is set by the output voltage measured at the CSP pin, V_{CSP} , and the input voltage measured at the VIN pin, V_{IN} , to maintain a pseudo-fixed frequency. During the on-time interval, the inductor current increases with a slope proportional to the voltage applied across its terminals ($V_{IN} - V_{CSP}$).

The low-side MOSFET is turned on after a fixed dead time and the inductor current then decreases with the constant slope proportional to the output voltage, V_{CSP} . Inductor current measured by the external sense resistor is compared to the valley threshold, V_{VAL} , by an internal high-speed comparator. This MOSFET is turned off and the one-shot timer is initiated when the sensed inductor current falls below the valley threshold voltage. The high-side MOSFET is turned on again after a fixed dead time.

The internal rail-to-rail error amplifier sets the valley threshold voltage and regulates the average inductor current based on a reference value set by V_{IADJ} pin. A simple integral loop compensation circuit consisting of a capacitor connected from the COMP pin to GND provides a stable and high-bandwidth response. As the inductor current is directly sensed by an external resistor, the device operation is not sensitive to the ESR of the output capacitors and is compatible with common multilayered ceramic capacitors (MLCC).

7.3.3 Bootstrap Supply

The TPS92643-Q1 contains both high-side and low-side N-channel MOSFETs. The high-side gate driver works in conjunction with an internal bootstrap diode and an external bootstrap capacitor, C_{BST} . During the on-time of the low-side MOSFET, the SW pin voltage is approximately 0 V and C_{BST} is charged from the VCC supply through the internal diode and external R_{BST} resistor. TI recommends a 0.1- μF to 2.2- μF capacitor and 2.2- Ω to 10- Ω resistor connected in series between the BST and SW pins.

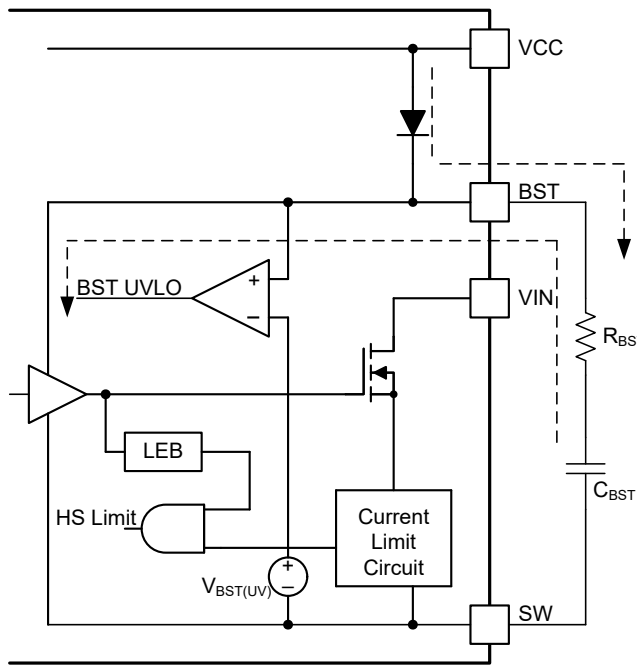

Figure 7-2. Bootstrap Network

A larger capacitor is required to prevent a bootstrap undervoltage fault when operating at low PWM dimming frequencies. Noise due to stored charge is reduced by the R_{BST} . In addition, the R_{BST} resistor allows optimization of EMI with respect to efficiency. A larger R_{BST} resistor results in lower SW node rise time and allows energy in SW node harmonics to roll off near 100-MHz frequency. Switching with slower slew rate also decreases the efficiency.

7.3.4 Switching Frequency and Adaptive On-Time Control

The TPS92643-Q1 uses an adaptive on-time control scheme and does not have a dedicated on-board oscillator. The one-shot timer is programmed by the R_{ON} resistor. The on-time is calculated internally using Equation 1 and is inversely proportional to the measured input voltage, V_{IN} , and directly proportional to the measured CSP voltage, V_{CSP} .

$$t_{ON} = 10 \times 10^{-12} \times R_{ON} \times \left(\frac{V_{CSP}}{V_{IN}} \right) \quad (1)$$

Given the duty ratio of the buck converter is V_{CSP}/V_{IN} , the switching period, T_{SW} , remains nearly constant over different operating points. Use Equation 2 to calculate the switching period.

$$T_{SW} = t_{ON} \times \left(\frac{V_{CSP}}{V_{IN}} \right) = 10 \times 10^{-12} \times R_{ON} \quad (2)$$

The switching frequency is calculated internally using [Equation 3](#).

$$f_{SW} = \frac{1}{10 \times 10^{-12} \times R_{ON}} \quad (3)$$

The minimum or maximum duty cycle is limited to finite minimum on-time, $T_{ON(MIN)}$ and minimum off-time, $T_{OFF(MIN)}$, respectively. As on-time is constant, the frequency is also a dependent on the efficiency of the device, η_{REG} , excluding inductor and sense resistor losses.

$$f_{SW} = \frac{1}{10 \times 10^{-12} \times R_{ON} \times \eta_{REG}} \quad (4)$$

TI recommends a switching frequency setting between 100 kHz and 2.2 MHz.

7.3.5 Minimum On-Time, Off-Time, and Inductor Ripple

Buck converter operation is impacted by minimum on-time, minimum off-time, and minimum peak-to-peak inductor ripple limitations. The converter reaches the minimum on-time of 96 ns (typical) when operating with high input voltage and low-output voltage. In this control scheme, the off-time continues to increase and the switching frequency reduces to regulate the inductor current and LED current to the desired value.

$$f_{SW(MIN)} = \frac{V_{OUT(MIN)}}{T_{ON(MIN)} \times V_{IN(MAX)}}; t_{ON} = t_{ON(MIN)} \quad (5)$$

The converter reaches the minimum off-time of 91 ns (typical) when operating in dropout (low input voltage and high output voltage). As the on-time and off-time are fixed, the duty cycle is constant and the buck converter operates in open-loop mode. The inductor current and LED current are not in regulation.

The behavior and response of valley comparator is dependent on sensed peak-to-peak voltage ripple, $\Delta V_{(CSP-CSN)}$, and is a function of current sense resistor, R_{CS} , and peak-to-peak inductor current ripple, $\Delta I_{L(PK-PK)}$. To ensure periodic switching, the sensed peak-to-peak ripple must exceed the minimum value. At high (near 100%) or low (near 0%) duty cycles, the inductor current ripple may not be sufficient to ensure periodic switching. Under such operating conditions, the converter transitions from periodic switching to a burst sequence, forcing multiple on-time and off-time cycles at a rate higher than the programmed frequency. Although the converter may not operate in a periodic manner, the closed-loop control continues regulating the average LED current with a larger ripple value corresponding to higher peak-to-peak inductor ripple. TI recommends choosing an inductor, output capacitor, and switching frequency to ensure minimum sensed peak-to-peak ripple voltage under nominal operating condition is greater than 8 mV. The [Application and Implementation](#) section summarizes the detailed design procedure.

7.3.6 LED Current Regulation and Error Amplifier

The reference voltage, V_{IADJ} , set by the V_{IADJ} and is internally scaled by a gain factor of 1/14 through a resistor network. An internal rail-to-rail error amplifier generates an error signal proportional to the difference between the scaled reference voltage ($V_{IADJ} / 14$) and the inductor current measured by the differential voltage drop between CSP and CSN, $V_{(CSP-CSN)}$. This error drives the COMP pin voltage, V_{COMP} , and directly controls the valley threshold of the inductor current. Zero average DC error and closed-loop regulation is achieved by implementing an integral compensation network consisting of a capacitor connected from the output of the error amplifier to GND. As a good starting point, TI recommends a capacitor value between 1 nF and 10 nF between the COMP pin and GND. The choice of compensation network must ensure a minimum of 60° of phase margin and 10 dB of gain margin.

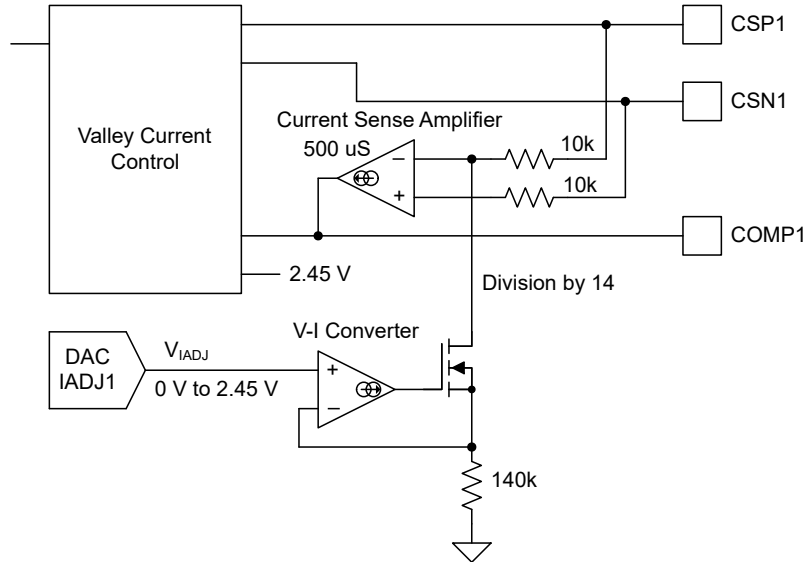

Figure 7-3. Closed-Loop LED Current Regulation

LED current is dependent on the current sense resistor, R_{CS} . Use [Equation 15](#) to calculate the LED current.

LED current accuracy is a function of the tolerance of the external sense resistor, R_{CS} , and the variation in the sense threshold, $V_{(CSP-CSN)}$, caused by internal mismatch and temperature dependency of the analog components. The TPS92643-Q1 incorporates low offset rail-to-rail amplifiers, and is capable of achieving LED current accuracy of $\pm 4\%$ over common-mode range and a junction temperature range of -40°C to 150°C .

7.3.7 Start-Up Sequence

The start-up circuit allows the COMP pin voltage to gradually increase, thus reducing the LED current overshoot and current surges. The switching operation is initiated after the COMP pin voltage exceeds 2.45 V. A 440-mV hysteresis window allows the device to operate when COMP voltage is within the expected operating range of 2.2 V to 2.7 V. Switching is disabled on detection of low COMP voltage to avoid excessive negative inductor current.

The duration of soft start, t_{SS} , depends on the size of the compensation capacitor and the error amplifier source current, $I_{COMP(SRC)}$.

$$t_{SS} = \frac{2.45 \times C_{COMP}}{I_{COMP(SRC)}} \quad (6)$$

The source current, $I_{COMP(SRC)}$ is a function of the transconductance, g_M , of the error amplifier and error generated between the reference and the current sensed voltage.

$$I_{COMP(SRC)} = g_M \times \left(\frac{V_{IADJ}}{14} - V_{(CSP-CSN)} \right) \quad (7)$$

With no current flowing through the LEDs, the soft start duration depends on the choice of compensation capacitor, C_{COMP} , and the reference voltage, V_{IADJ} .

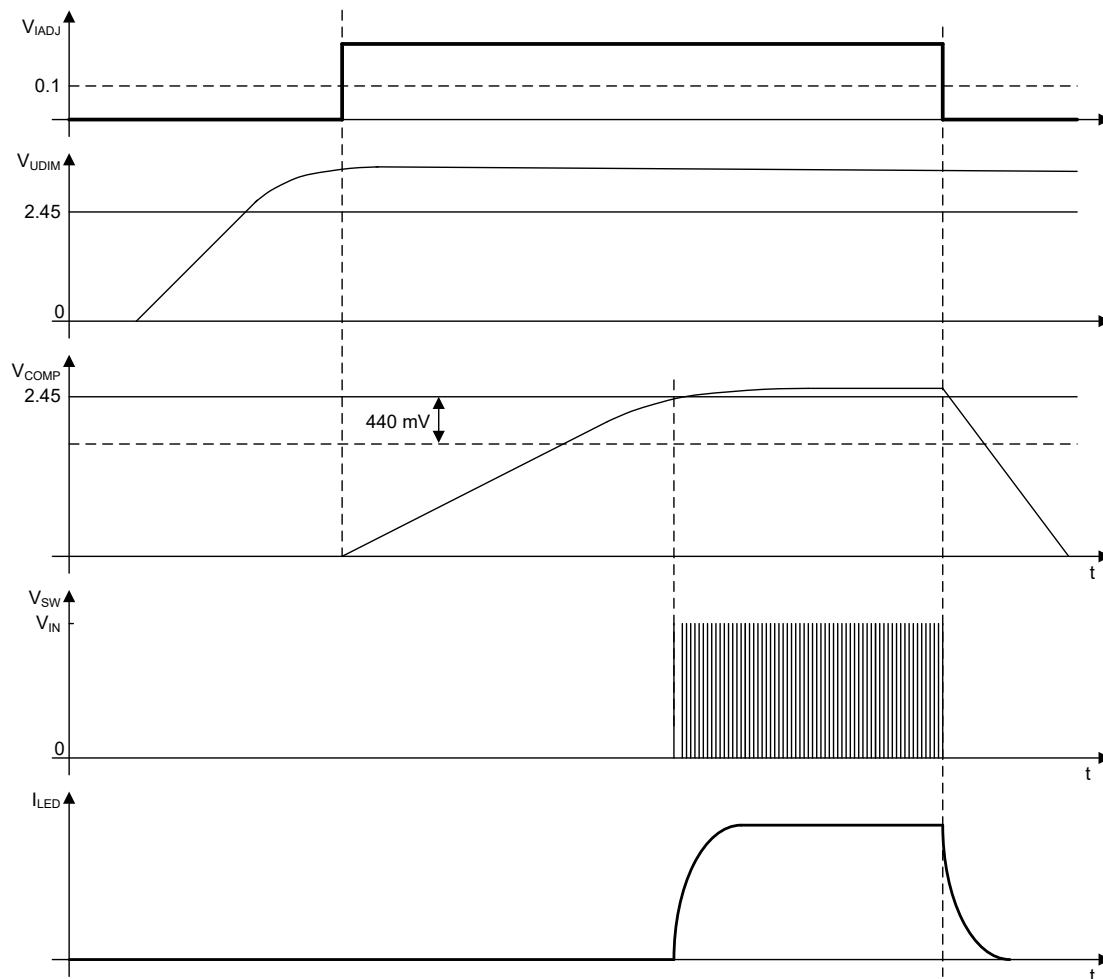

Figure 7-4. Soft-Start Sequence

The open drain fault indicator, \overline{FLT} , is set low when the COMP voltage deviates from the nominal range and exceeds $V_{COMP(OV)}$ threshold. This setting indicates a fault condition where the converter is operating in open-loop and the LED current is out of regulation. The device can be disabled by setting IADJ input below 100 mV or controlling the UDIM input.

7.3.8 Analog Dimming and Forced Continuous Conduction Mode

Analog dimming is accomplished by the voltage on IADJ pin, V_{IADJ} . The TPS92643-Q1 improves the linear range of analog dimming by supporting forced continuous conduction mode of operation. With synchronous MOSFETs, the inductor current is allowed to go negative for part of the switching cycle, thus enabling linear dimming with over 15:1 dimming range. TI recommends a 10-nF capacitor from IADJ pin to AGND pin to improve noise sensitivity.

7.3.9 External PWM Dimming and Input Undervoltage Lockout (UVLO)

The UDIM pin is a multifunction input that features an accurate input voltage detection based on band-gap thresholds with programmable hysteresis as shown in [Figure 7-5](#). This pin functions as the external PWM dimming input for the LEDs and monitors V_{IN} to detect dropout and undervoltage conditions. When the rising pin voltage exceeds the 2.45-V threshold, 10 μ A (typical) of current is driven out of the UDIM pin into the resistor divider providing programmable hysteresis. TI recommends a bypass capacitor value of 1 nF between the UDIM pin and GND to improve noise immunity.

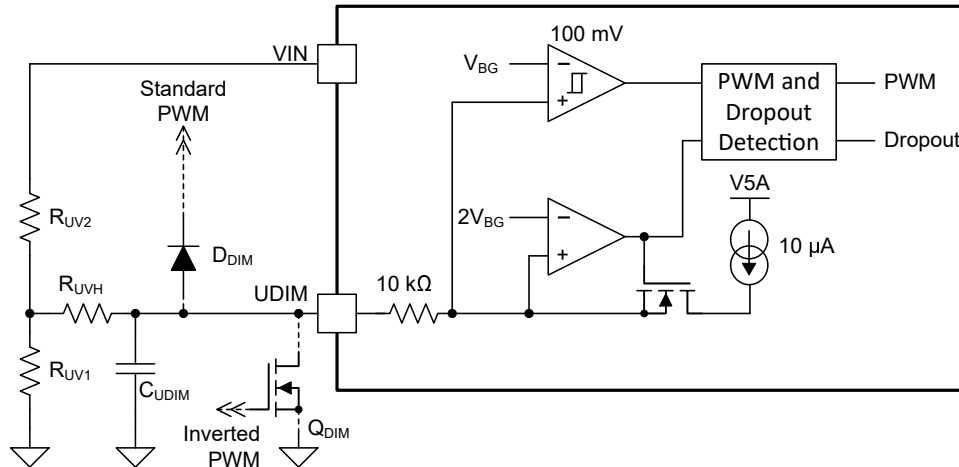

Figure 7-5. External PWM Dimming

The brightness of LEDs can be varied by modulating the duty cycle of the signal directly connected to the UDIM input. In addition, either an n-channel MOSFET or a Schottky diode can be used to couple an external PWM signal when using UDIM input in conjunction with UVLO functionality. With an n-channel MOSFET, the brightness is proportional to the negative duty cycle of the external PWM signal. With a Schottky diode, the brightness is proportional to the positive duty cycle of the external PWM signal.

Dropout and input undervoltage protection is achieved by connecting the resistor divider network from VIN to UDIM pin and UDIM pin to GND. Dropout protection is activated when UDIM pin voltage drops below $V_{UDIM(DO, FALL)}$ threshold but is held above $V_{UDIM(EN)}$ threshold. In dropout protection mode, the device disables the error amplifier and disconnects the COMP pin to maintain charge on the compensation network. The device continues switching, ensuring fast response with minimum led current overshoot as the converter recovers from dropout condition. The minimum input voltage, below which drop protection is activated is programmed using [Equation 8](#).

$$V_{IN(DO, FALL)} = V_{IN(DO, RISE)} - I_{UDIM(DO)} \times \left(R_{UV2} + \frac{(R_{UVH} + 10 \times 10^3) \times (R_{UV1} + R_{UV2})}{R_{UV1}} \right) \quad (8)$$

[Equation 9](#) shows the input voltage rising threshold. When VIN exceeds the rising threshold, the error amplifier is enabled, the COMP pin is connected to the compensation network. The control loop now regulates the LED current regulation.

$$V_{IN(DO, RISE)} = V_{UDIM(DO, RISE)} \times \frac{R_{UV1} + R_{UV2}}{R_{UV1}} \quad (9)$$

Additional hysteresis to internal 100 mV is programmed by connecting an external resistor, R_{UVH} in series with UDIM pin. This connection allows the standard resistor divider to have smaller values, minimizing PWM delays.

Input undervoltage protection is triggered when UDIM pin voltage drops below $V_{UDIM(EN)}$ thresholds. The device responds to very low VIN voltage or to the external PWM input signal by disabling the error amplifier, disconnecting the COMP pin and tri-stating the switch node. With switch disabled, inductor current and the LED current drops to zero and the charge on the compensation network is maintained. On rising edge of PWM or when VIN exceeds the internal hysteresis of 100 mV, the converter resumes switching operation. The inductor current quickly ramps to the previous steady-state value.

[Equation 10](#) defines the VIN UVLO rising threshold.

$$V_{IN(UVLO, RISE)} = V_{UDIM(EN, RISE)} \times \frac{R_{UV1} + R_{UV2}}{R_{UV1}} \quad (10)$$

Use [Equation 11](#) to determine the VIN UVLO falling threshold.

$$V_{IN(UVLO, FALL)} = V_{UDIM(EN, FALL)} \times \frac{R_{UV1} + R_{UV2}}{R_{UV1}} \quad (11)$$

7.3.10 Analog Pulse Width Modulator Circuit

The TPS92643-Q1 features analog circuitry to generate an internal PWM dimming signal. The frequency of the internal PWM signal is fixed to 1.5 kHz and the duty cycle is proportional to the applied voltage to APWM pin, V_{APWM} , according to Equation 12:

$$D_{PWM(INT)} = \frac{V_{APWM} - 1}{1.45} \times 100 \quad (12)$$

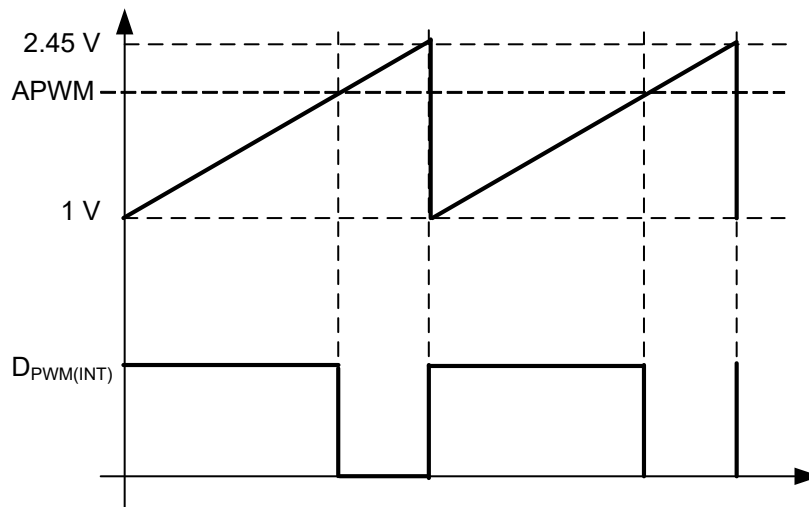

Figure 7-6. APWM Waveform

The internal PWM signal is ANDed with the external PWM signal applied to UDIM pin. Hence, if this pin is unused it should be tied to V_{CC} pin. The TPS92643-Q1 stops switching if V_{APWM} falls below 1.0 V. Pulse width modulated thermal fold-back can be implemented by connecting a NTC resistor, in conjunction with a voltage divider network, to APWM pin. TI recommends a bypass capacitor of 10 nF between APWM pin and GND to improve noise immunity.

7.3.11 Output Short and Open-Circuit Faults

The TPS92643-Q1 monitors the CSN voltage to detect output short circuit faults. A short failure is indicated by open drain \overline{FLT} output when the CSN voltage drops below 1.5 V (typical). The device continues to regulate current and operate without interruption in case of short circuit. A short-circuit fault does not impact the device behavior. The device continues to operate and regulate current without interruption.

An LED open-circuit fault ultimately causes the output voltage to increase and settle close to the input voltage. When this event occurs, the TPS92643-Q1 switching operation is then controlled by the fixed on-time and minimum off-time resulting in a duty cycle close to 100%. The COMP pin voltage exceeds the COMP overvoltage threshold, $V_{COMP(OV)}$, and the fault is indicated by \overline{FLT} output. However, during open circuit, the dynamic behavior of the device and buck converter is influenced by the input voltage, V_{IN} , and the output capacitor, C_{OUT} , value. The device response to open circuit can be categorized into the following two distinct cases.

Case 1: For a Buck converter design with a small output capacitor, the switching operation in open load condition exits the tank resonance forcing the output voltage to oscillate. The frequency and amplitude of the oscillation are based on the resonant frequency and Q-factor of the second order tank network.

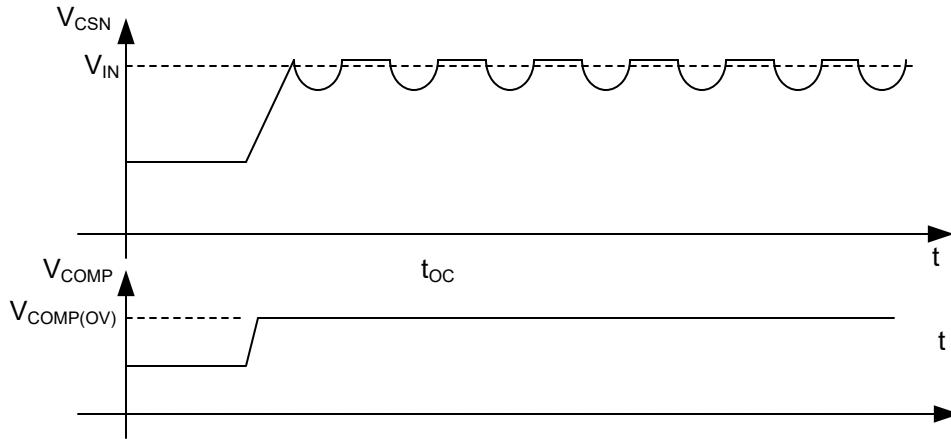

Figure 7-7. Open-Circuit Condition with Output Voltage Oscillation

Case 2: For a buck converter design with large output capacitor the inductor Q-factor and resonant frequency are much lower than the switching frequency. In this case, output voltage rises to input voltage and the converter continues to switch with minimum off-time.

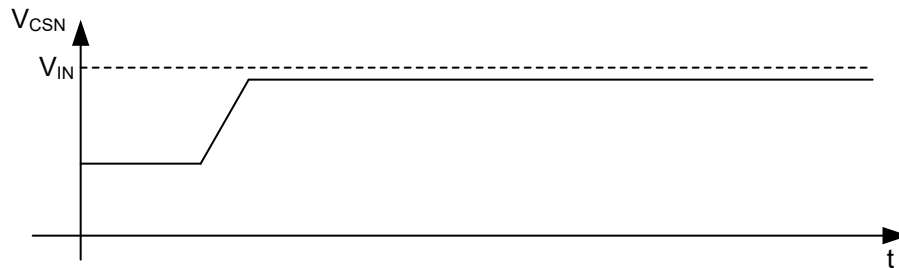

Figure 7-8. Open-Circuit Condition with Minimum Off-Time Operation

The voltage transient imposed on CSP and CSN inputs during short circuit and open circuit is dependent on the output capacitance and is influenced by the cable harness impedance. The inductance associated with a long cable harness resonates with the charge stored on the output capacitor and forces CSP and CSN voltage to ring above V_{IN} and below ground. The magnitude of the voltage overshoot above V_{IN} and below ground are dependent on the parasitic cable harness inductance and resistance.

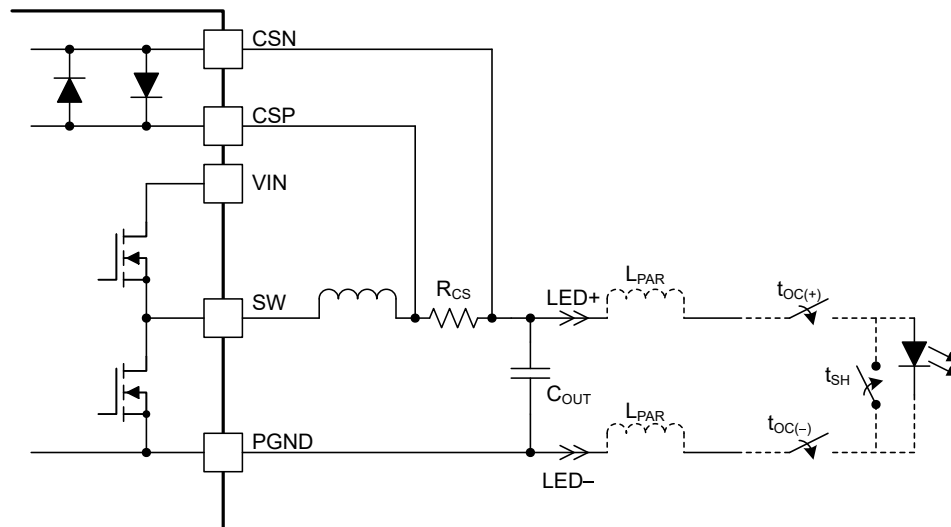

Figure 7-9. Cable Harness Parasitic Inductance

When using a long cable harness, TI recommends diodes to clamp the voltage across CSP and CSN input, as shown in Figure 7-10. TI recommends a low forward voltage Schottky diode or a fast recovery silicon diode with reverse blocking voltage rating greater than the maximum output voltage. The diode is required to be placed close to the output capacitor.

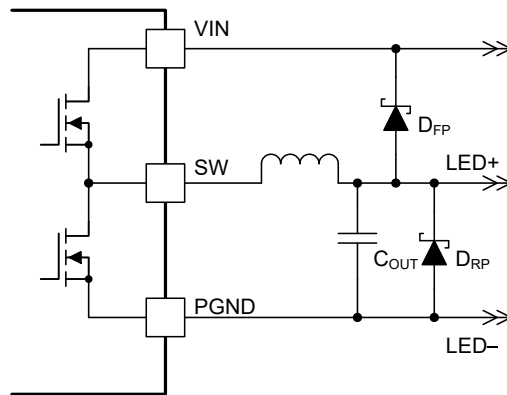

Figure 7-10. Transient Protection Using an External Diode

7.3.12 Overcurrent Protection

The device is protected from overcurrent conditions with cycle-by-cycle current limiting on both the high-side and the low-side MOSFETs.

The device turns off the high-side MOSFET and discharges the COMP capacitor when the drain current exceeds 4.8-A typical. The low-side switch is turned on to discharge the inductor current and output capacitor.

When the low-side switch is turned on, the switch current is also sensed and monitored. The device turns off both high-side and low-side MOSFETs and discharges the COMP capacitor when the drain current (from drain to PGND) exceeds 3.2-A typical.

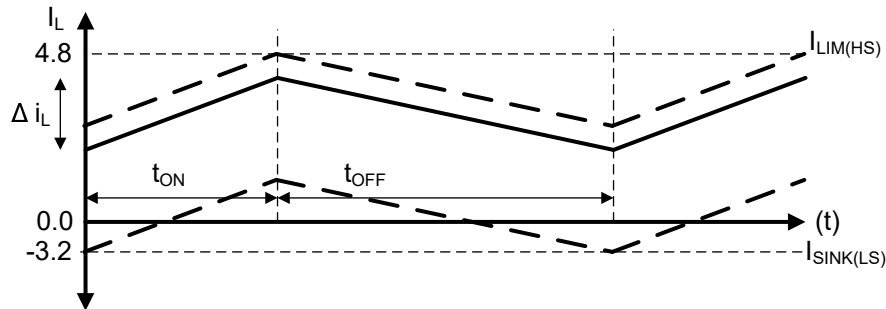

Figure 7-11. Overcurrent Protection Thresholds

The device employs hiccup mode overcurrent protection. In hiccup mode, the device shuts itself down and attempts to start after T_{OC} . Hiccup mode helps reduce the device power dissipation under severe overcurrent conditions.

7.3.13 Thermal Shutdown

Thermal shutdown prevents the device from extreme junction temperatures by turning off the internal switches when the IC junction temperature exceeds 175°C (typical). Thermal shutdown does not trigger below 158°C. After thermal shutdown occurs, hysteresis prevents the device from switching until the junction temperature drops to approximately 160°C. When the junction temperature falls below 160°C (typical), the device attempts to start up.

7.3.14 Fault Indicator and Diagnostics Summary

Table 7-1 summarizes the device behavior under fault conditions.

Table 7-1. Fault Description

FAULT	DETECTION	DESCRIPTION
Thermal protection	$T_J > 175^\circ\text{C}$	The thermal protection is activated in the event the maximum MOSFET temperature exceeds the typical value of 175°C. This feature is designed to prevent overheating and damage to the internal switching MOSFETs.
VCC undervoltage lockout	$V_{CC(\text{RISE})} < 4.4\text{ V}$	The device enters the Undervoltage Lockout (UVLO). The switching operation is disabled, the COMP capacitor is discharged.
	$V_{CC(\text{FALL})} < 4.2\text{ V}$	
VIN dropout protection	$V_{UDIM} < 2.34\text{ V}$	The device disables error amplifier and disconnects the compensation network for the corresponding channel. Error amplifier is enabled and compensation network is internally connected when the input voltage rises above the dropout rising threshold, $V_{IN(\text{DO,RISE})}$.
VIN undervoltage lockout	$V_{UDIM} < 1.12\text{ V}$	The device disables switching operation for the corresponding channel. Switching is enabled when the input voltage rises above the turn-on threshold, $V_{IN(\text{UVLO,RISE})}$.
BST undervoltage lockout	$V_{BST(\text{RISE})} < 3.2\text{ V}$	The device turns off the high-side MOSFET and turns on the low-side MOSFET for the corresponding channel. Normal switching operation is resumed after the bootstrap voltage exceeds 3.2 V.
	$V_{BST(\text{FALL})} < 2.93\text{ V}$	
COMP overvoltage	$V_{COMP} > 3.2\text{ V}$	The $\overline{\text{FLT}}$ flag is set low to indicate that the COMP voltage exceeded the normal operating range. This condition indicates output open-circuit fault.
Short output	$V_{CSN} < 1.5\text{ V}$	The $\overline{\text{FLT}}$ flag is set low to indicate an output short-circuit condition based on sensed CSN voltage.
High-side switch current limit	$I_{HS} > 4.8\text{ A}$	The device turns off the high-side MOSFET, turns on low-side MOSFET and discharges the COMP capacitor. The device attempts to restart after a delay of 5.5 ms.
Low-side switch current limit	$I_{LS} > 3.2\text{ A}$	The device turns off both high-side and low-side MOSFETs and discharges the COMP capacitor. The device attempts to restart after a delay of 5.5 ms.

Output open and short circuit faults force the $\overline{\text{FLT}}$ pin low when biased through an external resistor and connected to a 5-V supply. The $\overline{\text{FLT}}$ output can be used in conjunction with a microcontroller or system basis chip (SBC) as an interrupt and aid in fault diagnostics.

7.4 Device Functional Modes

This device has no additional functional modes.

8.1.1 Duty Cycle Considerations

The switch duty cycle, D, defines the converter operation and is a function of the input and output voltages. In steady state, the duty cycle is defined using [Equation 13](#):

$$D = \frac{V_{CSN}}{V_{IN}} \quad (13)$$

The buck converter maximum operating duty cycle, D_{MAX} , at minimum input voltage, $V_{IN,MIN}$ and maximum LED voltage, $V_{CSN,MAX}$.

$$D_{MAX} = \frac{V_{CSN,MAX}}{V_{IN,MIN}} \quad (14)$$

There is no limitation for small duty cycles, because at low duty cycles, the switching frequency is reduced as needed to always ensure current regulation. The maximum duty cycle attainable is limited by the minimum off-time duration and is a function of switching frequency.

8.1.2 Switching Frequency Selection

Nominal switching frequency is set by programming the R_{ON} resistor. The switching varies slightly over operating range and temperature based on converter efficiency. [Table 8-1](#) shows common switching frequencies and corresponding R_{ON} resistor values.

Table 8-1. Center Switching Frequency Setting

R_{ON} (k Ω)	SWITCHING FREQUENCY (kHz)
267	400
243	435
221	480
50	2000
44.2	2200

8.1.3 LED Current Programming

The LED current is set by the external current sense resistor, R_{CS} , and the analog adjust voltage, V_{IADJ} . The LED current can be programmed by varying V_{IADJ} between 140 mV to 2.3 V. The LED current can be calculated using [Equation 15](#):

$$I_{LED} = \frac{V_{IADJ}}{14 \times R_{CS}} \quad (15)$$

The LED current can be programmed by varying V_{IADJ} between 140 mV and 2.3 V. TI recommends a 10-nF capacitor from IADJ pin to AGND pin to filter high frequency switching noise.

8.1.4 Inductor Selection

The inductor is sized to meet the ripple specification at maximum operating duty cycle. TI recommends a minimum sensed peak-to-peak voltage ripple ($\Delta V_{(CSP-CSN)}$) of 8 mV to ensure periodic switching operation under.

$$\Delta V_{(CSP-CSN)} = \Delta i_L \times R_{CS} \quad (16)$$

Use [Equation 17](#) to calculate the inductor value.

$$L = \frac{V_{IN,MIN} - V_{CSN,MAX}}{\Delta i_L \times f_{SW}} \times \frac{V_{CSN,MAX}}{V_{IN,MIN}} \quad (17)$$

The maximum inductor current ripple occurs at 50% duty cycle. Use [Equation 18](#) to calculate the maximum peak-to-peak inductor current ripple, $\Delta i_{L(MAX)}$.

$$\Delta i_{L(MAX)} = \frac{V_{IN(TYP)}}{4 \times L \times f_{SW}} \quad (18)$$

Use [Equation 19](#) and [Equation 20](#) to calculate the RMS and peak currents through the inductor. Make sure that the inductor is rated to handle these currents.

$$i_{L(RMS)} = \sqrt{\left(I_{LED(MAX)}^2 + \frac{\Delta i_{L(MAX)}^2}{12} \right)} \quad (19)$$

$$i_{L(PK)} = I_{LED(MAX)} + \frac{\Delta i_{L(MAX)}}{2} \quad (20)$$

8.1.5 Output Capacitor Selection

The output capacitor value depends on the total series resistance of the LED string, r_D , and the switching frequency, f_{SW} . The capacitance required for the target LED ripple current, Δi_{LED} , is calculated using [Equation 21](#).

$$C_{OUT} = \frac{\Delta i_{L(MAX)}}{8 \times f_{SW} \times r_D \times \Delta i_{LED}} \quad (21)$$

When choosing the output capacitors, consider the ESR and ESL characteristics because they directly impact the LED current ripple. Ceramic capacitors are the best choice due to the following:

- Low ESR
- High ripple current rating
- Long lifetime
- Good temperature performance

With ceramic capacitor technology, consider the derating factors associated with higher temperature and DC bias operating conditions. TI recommends an X7R dielectric with a voltage rating greater than maximum LED stack voltage.

8.1.6 Input Capacitor Selection

The input capacitor buffers the input voltage for transient events and decouples the converter from the supply. TI recommends a 10- μ F input capacitor across the VIN pin and PGND placed close to the device, and connected using wide traces. X7R-rated ceramic capacitors are the best choice due to the low ESR, high ripple current rating, and good temperature performance.

In addition, a small case size 100-nF ceramic capacitor must be used across VIN to PGND, immediately adjacent to the device. This usage provides a high-frequency bypass for the control circuits internal to the device. These capacitors also suppress SW node ringing, which reduces the maximum voltage present on the SW node and EMI.

The capacitance can be increased to further limit the input voltage deviation during PWM dimming operation.

8.1.7 Bootstrap Capacitor Selection

The bootstrap capacitor biases the high-side gate driver during the high-side FET on-time. The required capacitance depends on the PWM dimming frequency, PWM_{FREQ} , and is sized to avoid boot undervoltage and fault during PWM dimming operation. The bootstrap capacitance, C_{BST} , is calculated using [Equation 22](#):

$$C_{BST} = \frac{I_{Q(BST,MAX)}}{(V_{CC} + V_{BST(HYS)} - V_{BST(UV)}) \times PWM_{FREQ}} \quad (22)$$

[Table 8-2](#) summarizes the TI recommended bootstrap capacitor value for different PWM dimming frequencies.

Table 8-2. Bootstrap Capacitor Value

PWM DIMMING FREQUENCY (Hz)	BOOTSTRAP CAPACITOR (μF)
1500	0.1
1300	0.15
1000	0.22
800	0.22
600	0.33
400	0.47
200	1
100	2.2

8.1.8 Bootstrap Resistor Selection

A resistor can be connected between the C_{BST} capacitor and BST pin. A 4.7 resistor between the pins eliminates overshoot. Even with 2.2 Ω, overshoot and ringing are minimal, less than 4 V if input capacitors are placed correctly. A resistor value above 10 Ω is undesirable because the resulting incremental improvement in EMI is not enough to justify further decreased efficiency.

8.1.9 Compensation Capacitor Selection

TI recommends a simple integral compensator to achieve stable operation across the wide operating range. The buck converter behaves as a single pole system with additional phase lag caused by the switching behavior. The gain and phase margin are, consequently determined by the choice of the switching frequency and are independent of other design parameters. TI recommends a 1-nF to 10-nF capacitor to achieve bandwidth between 4 kHz and 40 kHz. The choice of compensation capacitor impacts the transient response and PWM dimming performance. TI recommends a larger compensation capacitor (lower bandwidth) to limit the LED current overshoot on the rising edge of internal or external PWM signal.

Table 8-3. Compensation Capacitor Value

BANDWIDTH (kHz)	BOOTSTRAP CAPACITOR (nF)
40	1
18	2.2
12	3.3
8.5	4.7
5.8	6.8
4.8	8.2
4	10

8.1.10 Input Dropout and Undervoltage Protection

Figure 8-1 shows that the undervoltage protection threshold is programmed using a resistor divider, R_{UV1} and R_{UV2}, from the input voltage, V_{IN} to PGND. Use Equation 23 and Equation 24 to calculate the resistor values.

$$R_{UV2} = \frac{2 \times V_{IN(UVLO, RISE)}}{I_{UDIM(DO)}} - \frac{V_{IN(DO, FALL)}}{I_{UDIM(DO)}} - 10 \times 10^3 \quad (23)$$

$$R_{UV1} = \frac{V_{UDIM(EN, RISE)}}{V_{IN(UVLO, RISE)} - V_{UDIM(EN, RISE)}} \times R_{UV2} \quad (24)$$

A capacitor of 1 nF from UDIM pin to GND is placed close to device to improve noise immunity.

8.1.11 APWM Input and Thermal Protection

Figure 8-1 shows APWM input can be used in conjunction with NTC resistor to implement thermal foldback protection. TI recommends a network of 10-kΩ resistor and a 100-kΩ NTC with β-value (25/50°C) of 4250 K to implement thermal fold back from 80°C to 125°C.

8.1.12 Protection Diodes

External Schottky diodes are required to protect the CSP / CSN node by clamping the voltage during short circuit and open-circuit transients. The Schottky diode must be selected based on the length of the cable harness and the choice of output capacitor. TI recommends a Schottky diode with low forward voltage drop at room-temperature and non-repetitive peak surge current rating of 10 A for duration of 5 μ s. The diodes from CSN to VIN and GND to CSN must be located close to the pin.

8.2 Typical Application

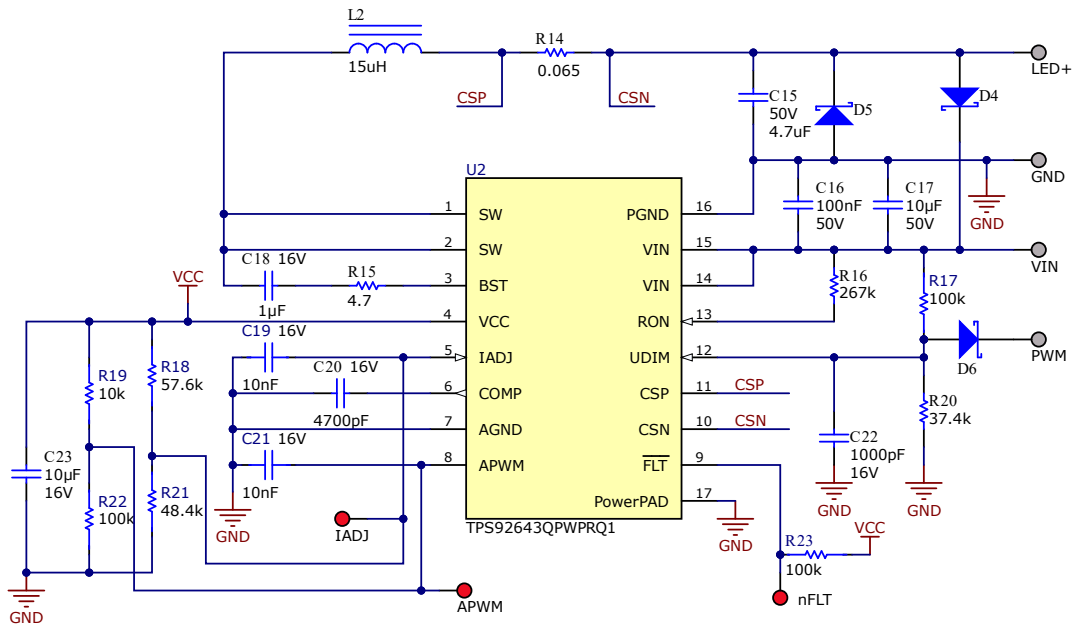

Figure 8-2. Application Schematic

8.2.1 Design Requirements

Table 8-4. Design Parameters

PARAMETER	CONDITIONS	MIN	TYP	MAX	UNIT
V_{IN}	Input voltage	8	13.5	36	V
N_S	Number of LEDs		2		
V_{FLED}	LED forward voltage drop	2.6	3	3.4	V
r_D	LED string series resistance	$N \times r_{D(LED)}$	200	500	m Ω
V_{CSN}	Output voltage	$N_S \times V_{FLED}$	6	6.8	V
I_{LED}	LED current continuous	100		2500	mA
Δi_{LED}	LED current ripple			80	mA
Δi_L	Inductor current ripple	Defined as percentage peak-to-peak at maximum LED current	6.2		%
$V_{IN(DO,RISE)}$	Start input voltage	Input voltage rising	9		V
$V_{IN(DO,FALL)}$	Stop input voltage	Input voltage falling	7.9		V
f_{PWM}	PWM frequency		200		Hz
D_{PWM}	PWM dimming duty cycle	4		100	%
f_{SW}	Switching frequency		400		kHz
T_A	Ambient temperature		25		$^{\circ}$ C

8.2.2 Detailed Design Procedure

8.2.2.1 Calculating Duty Cycle

Solve for duty cycle D, D_{MAX}, and D_{MIN}:

$$D_{MAX} = \frac{V_{CSN(MAX)}}{V_{IN(MIN)}} = \frac{6.8}{8} = 0.85 \quad (25)$$

$$D_{MIN} = \frac{V_{CSN(MIN)}}{V_{IN(MAX)}} = \frac{5.2}{36} = 0.144 \quad (26)$$

8.2.2.2 Calculating Minimum On-Time and Off-Time

Solve for minimum on-time, t_{ON(DMIN)} at minimum duty cycle and minimum off-time, t_{OFF(DMAX)} at maximum duty cycle:

$$t_{ON(DMAX)} = \frac{V_{CSN(MAX)}}{V_{IN(MIN)}} \times \frac{1}{f_{sw}} = \frac{6.8}{8} \times \frac{1}{400 \times 10^3} = 2125 \text{ ns} \quad (27)$$

$$t_{ON(DMIN)} = \frac{V_{CSN(MIN)}}{V_{IN(MAX)}} \times \frac{1}{f_{sw}} = \frac{5.2}{36} \times \frac{1}{400 \times 10^3} = 360 \text{ ns} \quad (28)$$

8.2.2.3 Minimum Switching Frequency

Confirm minimum switching frequency at t_{ON(DMIN)}, f_{SW(MIN)}:

$$f_{sw(MIN)} = \frac{V_{CSN(MIN)}}{t_{ON(DMIN)} \times V_{IN(MAX)}} = \frac{5.2}{360 \times 10^{-9} \times 36} = 401.2 \text{ kHz} \quad (29)$$

For the design specification, t_{ON(DMIN)} > t_{ON(MIN)} and f_{SW(MIN)} = f_{SW}.

8.2.2.4 LED Current Set Point

Solve for sense resistor, R_{CS}:

$$R_{CS} = \frac{V_{IADJ(MAX)}}{14 \times I_{LED(MAX)}} = \frac{2.3}{14 \times 2.5} = 0.0657 \quad (30)$$

A standard resistor of 65 mΩ with tolerance better than 1 % and low temperature coefficient is selected. The power dissipated in R_{CS} is calculated:

$$P_{sense} = R_{CS} \times I_{LED(MAX)}^2 = 0.065 \times 2.5^2 = 0.406 \text{ W} \quad (31)$$

A resistor with rated power of 500 mW and above must be selected.

A resistor divider network, with standard values 57.6 kΩ and 48.4 kΩ, from VCC pin to GND sets the maximum LED current reference voltage of 2.3 V. A 10-nF capacitor from IADJ pin to AGND pin is included to filter high frequency switching noise.

8.2.2.5 Inductor Selection

The inductor is selected to meet the recommended peak-to-peak voltage ripple, ΔV_(CSP-CSN):

$$L = \frac{V_{IN, MIN} - V_{CSN, MAX}}{\Delta i_L \times f_{SW}} \times \frac{V_{CSN, MAX}}{V_{IN, MIN}} = \frac{8 - 6.8}{155 \times 10^{-3} \times 400 \times 10^3} \times \frac{6.8}{8} = 16.45 \times 10^{-6} \quad (32)$$

The closest standard capacitor is 15 μH.

- Lower inductor values increase the peak-to-peak inductor current, which minimizes size and cost at the expense of reduced efficiency and larger output capacitor.
- Higher inductance values decrease the peak-to-peak inductor current, which increases efficiency but reduces the operating range based on minimum sense voltage ripple, $\Delta V_{(CSP-CSN)}$ specification.

8.2.2.6 Output Capacitor Selection

The minimum output capacitance is selected to meet the LED current ripple specification:

$$C_{OUT} = \frac{\Delta i_{L(MAX)}}{8 \times f_{SW} \times r_{D(MAX)} \times \Delta i_{LED}} = \frac{0.5625}{8 \times 400 \times 10^3 \times 0.5 \times 80 \times 10^{-3}} = 4.4 \times 10^{-6} \quad (33)$$

A standard 4.7- μ F, 50-V X7R capacitor is selected.

8.2.2.7 Bootstrap Capacitor Selection

Referring to [Table 8-2](#), a standard 1- μ F, 16-V X7R capacitor is selected to support PWM frequency of 200 Hz.

8.2.2.8 Bootstrap Resistor Selection

A standard 4.7- Ω bootstrap resistor is selected to limit ringing and mitigate EMI.

8.2.2.9 Compensation Capacitor Selection

A compensation capacitor of 4.7 nF is selected to achieve balanced transient response between PWM dimming and shunt FET dimming.

8.2.2.10 VIN Dropout Protection and PWM Dimming

The resistor divider, R_{UV1} and R_{UV2} , is set to meet $V_{IN(UVLO,RISE)}$ and $V_{IN(DO,FALL)}$ thresholds.

$$R_{UV2} = \frac{2 \times 4.5}{10 \times 10^{-6}} - \frac{7.9}{10 \times 10^{-6}} - 10 \times 10^3 = 100 \times 10^3 \quad (34)$$

$$R_{UV1} = \frac{1.22}{4.5 - 1.22} \times 100 \times 10^3 = 37.2 \times 10^3 \quad (35)$$

A standard value resistors of 100 k Ω and 37.4 k Ω are selected for R_{UV2} and R_{UV1} , respectively.

The external PWM signal is achieved by controlling UDIM input. The device modulates the LED current based on the PWM duty cycle of the external signal, coupled through external diode.

8.2.3 Application Curves

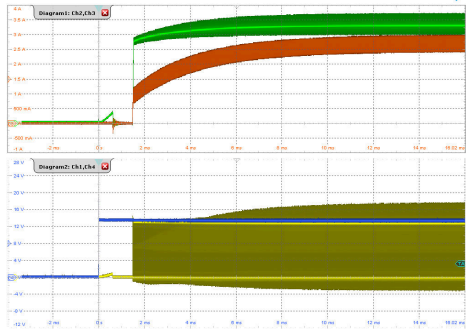

Ch1: SW voltage (4 V/div); Ch2: Output voltage (1 V/div); Ch3: Inductor current (500 mA/div); Ch4: VIN voltage (4 V/div); Time: 2 ms/div

Figure 8-3. Start-up Transient

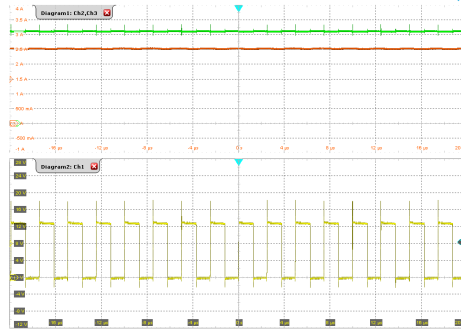

Ch1: SW voltage (4 V/div); Ch2: Output voltage (1 V/div); Ch3: LED current (500 mA/div); Time: 4 μs/div

Figure 8-4. Normal Operation

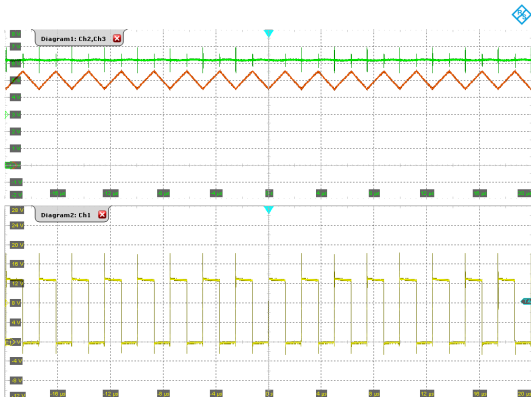

Ch1: SW voltage (4 V/div); Ch2: Output voltage (1 V/div); Ch3: Inductor current (500 mA/div); Time: 4 μs/div

Figure 8-5. Normal Operation

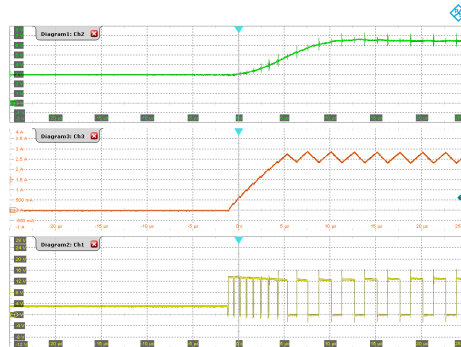

Ch1: SW voltage (4 V/div); Ch2: Output voltage (1 V/div); Ch3: Inductor current (500 mA/div); Time: 5 μs/div

Figure 8-6. PWM Dimming (Rising Edge)

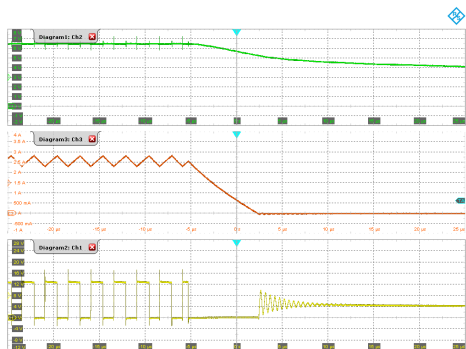

Ch1: SW voltage (4 V/div); Ch2: Output voltage (1 V/div); Ch3: Inductor current (500 mA/div); Time: 5 μs/div

Figure 8-7. PWM Dimming (Falling Edge)

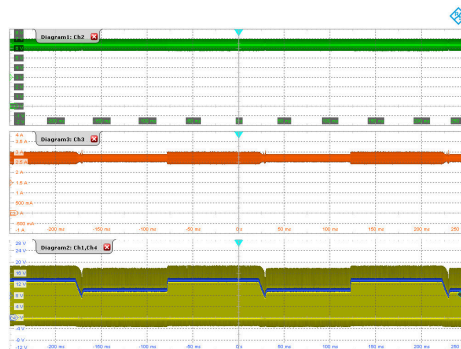

Ch1: SW voltage (4 V/div); Ch2: Output voltage (1 V/div); Ch3: LED current (500 mA/div); Ch4: VIN voltage (4 V/div); Time: 50 ns/div

Figure 8-8. Input Dropout Transient

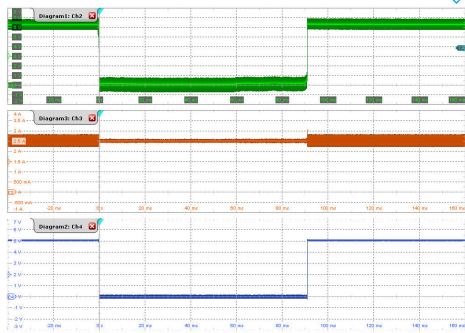

Ch2: Output voltage (1 V/div); Ch3: LED current (500 mA/div);
Ch4: $\overline{\text{FLT}}$ voltage (1 V/div); Time: 20 ms/div

Figure 8-9. Output Short-Circuit Fault

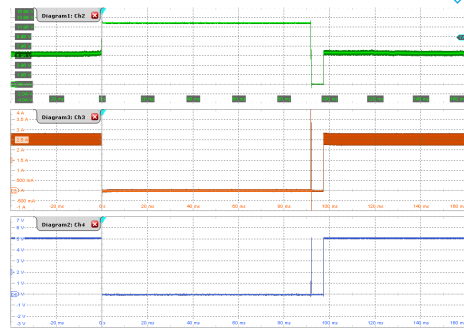

Ch2: Output voltage (1 V/div); Ch3:
LED current (500 mA/div); Ch4: FLT
voltage (1 V/div); Time: 20 ms/div

Figure 8-10. Output Open-Circuit Fault

9 Power Supply Recommendations

The characteristics of the input supply must be compatible with [Absolute Maximum Ratings](#) and [Recommended Operating Conditions](#) in this data sheet. In addition, the input supply must be capable of delivering the required input current to the loaded converter.

If the converter is connected to the input supply through long wires or PCB traces, special care is required to achieve good performance. The parasitic inductance and resistance of the input cables can have an adverse effect on the operation of the converter. The parasitic inductance, in combination with the low-ESR, ceramic input capacitors, can form an under-damped resonant circuit, resulting in overvoltage transients at the input to the converter or tripping UVLO. Additional bulk capacitance or an input filter can be required in addition to the ceramic bypass capacitors to address converter stability, noise, and EMI concerns.

10 Layout

10.1 Layout Guidelines

The performance of any switching converter depends as much on the layout of the PCB as the component selection. The following guidelines can help design a PCB with the best power converter performance.

- Place ceramic high-frequency bypass capacitors as close as possible to the TPS92643-Q1 VIN and PGND pins. Grounding for both the input and output capacitors must consist of localized top side planes that connect to the PGND pin.
- Place bypass capacitors for VCC close to the pins and ground the capacitors to device ground.
- Use wide traces for the C_{BST} capacitor and R_{BST} resistor. Place R_{BST} and C_{BST} network as close as possible to BST pin and SW pin.
- Differentially route the CSP and CSN pins to sense resistor. Route the traces away from noisy nodes, preferably through a layer on the other side of a shielding/ground layer.
- Use ground plane in one of the middle layers for noise shielding.
- Make VIN and ground connection as wide as possible. This action reduces any voltage drops on the input of the converter and maximizes efficiency.
- Keep switch area small. Keep the copper area connecting the SW pin to the inductor as short and wide as possible. At the same time, the total area of this node must be minimized to help reduce radiated EMI.

10.1.1 Compact Layout for EMI Reduction

Radiated EMI is generated by the high di/dt from pulsing currents in switching converters. The larger the area covered by the path of a pulsing current, the more electromagnetic emission is generated. The key to minimize radiated EMI is to identify the pulsing current path and minimize the area of the path. In buck converters, the pulsing current path is from the VIN side of the input capacitors through the HS switch, through the LS switch, and then returns to the ground of the input capacitor.

High-frequency ceramic bypass capacitors at the input side provide primary path for the high di/dt components of the pulsing current. Placing ceramic capacitors as close as possible to the VIN and PGND pins is the key to EMI reduction.

The PCB copper connection of the SW pin to the inductor must be as short as possible and just wide enough to carry the LED current without excessive heating. Short, thick traces or, copper pours (shapes), must be used for high current conduction path to minimize parasitic resistance. Place the output capacitor close to the CSN pin and grounded closely to the PGND pin.

10.1.1.1 Ground Plane

TI recommends using one of the middle layers as a solid ground plane. The ground plane provides shielding for sensitive circuits and traces. The ground plane also provides a quiet reference potential for the control circuitry. Connect the GND, AGND and PGND pins to the ground plane using via right next to the bypass capacitors. PGND pins are connected to the source of the internal LS switch. They must be connected directly to the grounds of the input and output capacitors. The PGND net contains noise at the switching frequency and can bounce due to load variations.

10.2 Layout Example

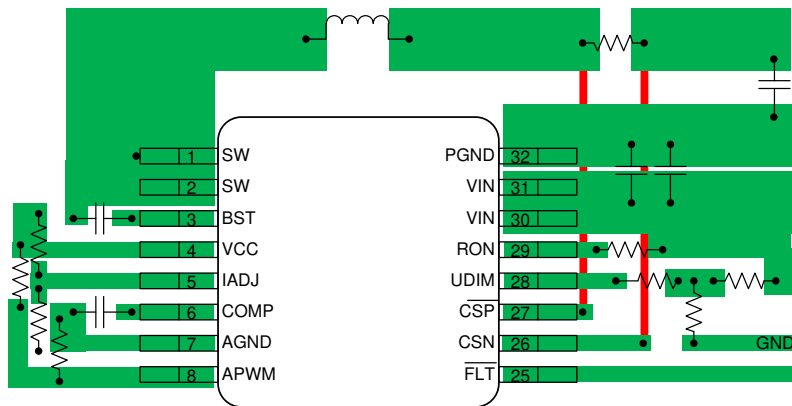

Figure 10-1. TPS92643-Q1 Layout Example

11 Device and Documentation Support

11.1 Receiving Notification of Documentation Updates

To receive notification of documentation updates, navigate to the device product folder on ti.com. Click on *Subscribe to updates* to register and receive a weekly digest of any product information that has changed. For change details, review the revision history included in any revised document.

11.2 Support Resources

[TI E2E™ support forums](#) are an engineer's go-to source for fast, verified answers and design help — straight from the experts. Search existing answers or ask your own question to get the quick design help you need.

Linked content is provided "AS IS" by the respective contributors. They do not constitute TI specifications and do not necessarily reflect TI's views; see TI's [Terms of Use](#).

11.3 Trademarks

TI E2E™ is a trademark of Texas Instruments.
All trademarks are the property of their respective owners.

11.4 Electrostatic Discharge Caution



This integrated circuit can be damaged by ESD. Texas Instruments recommends that all integrated circuits be handled with appropriate precautions. Failure to observe proper handling and installation procedures can cause damage.

ESD damage can range from subtle performance degradation to complete device failure. Precision integrated circuits may be more susceptible to damage because very small parametric changes could cause the device not to meet its published specifications.

11.5 Glossary

[TI Glossary](#) This glossary lists and explains terms, acronyms, and definitions.

12 Mechanical, Packaging, and Orderable Information

The following pages include mechanical, packaging, and orderable information. This information is the most current data available for the designated devices. This data is subject to change without notice and revision of this document. For browser-based versions of this data sheet, refer to the left-hand navigation.

PACKAGING INFORMATION

Orderable Device	Status (1)	Package Type	Package Drawing	Pins	Package Qty	Eco Plan (2)	Lead finish/ Ball material (6)	MSL Peak Temp (3)	Op Temp (°C)	Device Marking (4/5)	Samples
TPS92643QPWRQ1	ACTIVE	HTSSOP	PWP	16	2000	RoHS & Green	NIPDAU	Level-3-260C-168 HR	-40 to 125	92643Q	Samples

(1) The marketing status values are defined as follows:

ACTIVE: Product device recommended for new designs.

LIFEBUY: TI has announced that the device will be discontinued, and a lifetime-buy period is in effect.

NRND: Not recommended for new designs. Device is in production to support existing customers, but TI does not recommend using this part in a new design.

PREVIEW: Device has been announced but is not in production. Samples may or may not be available.

OBSELETE: TI has discontinued the production of the device.

(2) **RoHS:** TI defines "RoHS" to mean semiconductor products that are compliant with the current EU RoHS requirements for all 10 RoHS substances, including the requirement that RoHS substance do not exceed 0.1% by weight in homogeneous materials. Where designed to be soldered at high temperatures, "RoHS" products are suitable for use in specified lead-free processes. TI may reference these types of products as "Pb-Free".

RoHS Exempt: TI defines "RoHS Exempt" to mean products that contain lead but are compliant with EU RoHS pursuant to a specific EU RoHS exemption.

Green: TI defines "Green" to mean the content of Chlorine (Cl) and Bromine (Br) based flame retardants meet JS709B low halogen requirements of <=1000ppm threshold. Antimony trioxide based flame retardants must also meet the <=1000ppm threshold requirement.

(3) MSL, Peak Temp. - The Moisture Sensitivity Level rating according to the JEDEC industry standard classifications, and peak solder temperature.

(4) There may be additional marking, which relates to the logo, the lot trace code information, or the environmental category on the device.

(5) Multiple Device Markings will be inside parentheses. Only one Device Marking contained in parentheses and separated by a "-" will appear on a device. If a line is indented then it is a continuation of the previous line and the two combined represent the entire Device Marking for that device.

(6) Lead finish/Ball material - Orderable Devices may have multiple material finish options. Finish options are separated by a vertical ruled line. Lead finish/Ball material values may wrap to two lines if the finish value exceeds the maximum column width.

Important Information and Disclaimer:The information provided on this page represents TI's knowledge and belief as of the date that it is provided. TI bases its knowledge and belief on information provided by third parties, and makes no representation or warranty as to the accuracy of such information. Efforts are underway to better integrate information from third parties. TI has taken and continues to take reasonable steps to provide representative and accurate information but may not have conducted destructive testing or chemical analysis on incoming materials and chemicals. TI and TI suppliers consider certain information to be proprietary, and thus CAS numbers and other limited information may not be available for release.

In no event shall TI's liability arising out of such information exceed the total purchase price of the TI part(s) at issue in this document sold by TI to Customer on an annual basis.

TAPE AND REEL INFORMATION

QUADRANT ASSIGNMENTS FOR PIN 1 ORIENTATION IN TAPE



*All dimensions are nominal

Device	Package Type	Package Drawing	Pins	SPQ	Reel Diameter (mm)	Reel Width W1 (mm)	A0 (mm)	B0 (mm)	K0 (mm)	P1 (mm)	W (mm)	Pin1 Quadrant
TPS92643QPWPRQ1	HTSSOP	PWP	16	2000	330.0	12.4	6.9	5.6	1.6	8.0	12.0	Q1

TAPE AND REEL BOX DIMENSIONS

*All dimensions are nominal

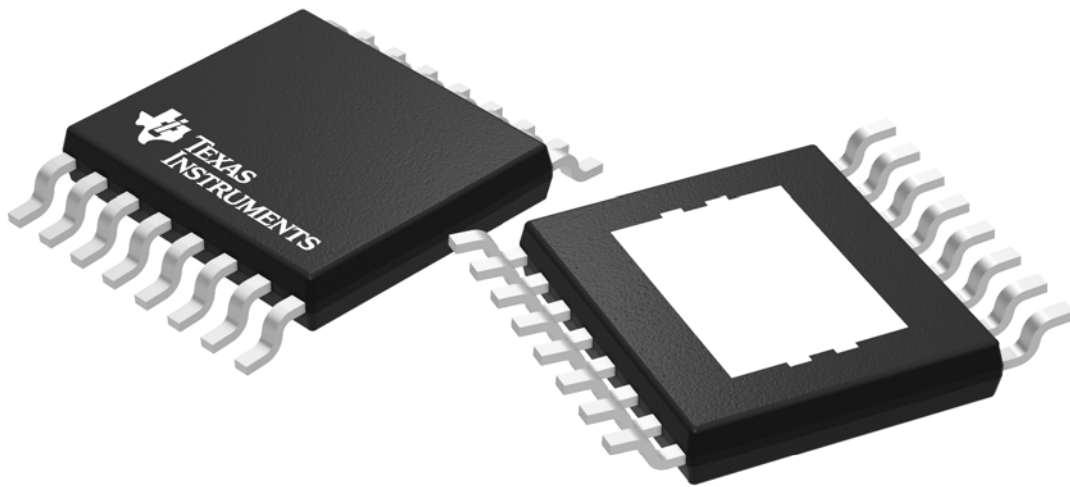
Device	Package Type	Package Drawing	Pins	SPQ	Length (mm)	Width (mm)	Height (mm)
TPS92643QPWPRQ1	HTSSOP	PWP	16	2000	350.0	350.0	43.0



Images above are just a representation of the package family, actual package may vary.
Refer to the product data sheet for package details.

IMPORTANT NOTICE AND DISCLAIMER

TI PROVIDES TECHNICAL AND RELIABILITY DATA (INCLUDING DATA SHEETS), DESIGN RESOURCES (INCLUDING REFERENCE DESIGNS), APPLICATION OR OTHER DESIGN ADVICE, WEB TOOLS, SAFETY INFORMATION, AND OTHER RESOURCES "AS IS" AND WITH ALL FAULTS, AND DISCLAIMS ALL WARRANTIES, EXPRESS AND IMPLIED, INCLUDING WITHOUT LIMITATION ANY IMPLIED WARRANTIES OF MERCHANTABILITY, FITNESS FOR A PARTICULAR PURPOSE OR NON-INFRINGEMENT OF THIRD PARTY INTELLECTUAL PROPERTY RIGHTS.

These resources are intended for skilled developers designing with TI products. You are solely responsible for (1) selecting the appropriate TI products for your application, (2) designing, validating and testing your application, and (3) ensuring your application meets applicable standards, and any other safety, security, regulatory or other requirements.

These resources are subject to change without notice. TI grants you permission to use these resources only for development of an application that uses the TI products described in the resource. Other reproduction and display of these resources is prohibited. No license is granted to any other TI intellectual property right or to any third party intellectual property right. TI disclaims responsibility for, and you will fully indemnify TI and its representatives against, any claims, damages, costs, losses, and liabilities arising out of your use of these resources.

TI's products are provided subject to [TI's Terms of Sale](#) or other applicable terms available either on [ti.com](https://www.ti.com) or provided in conjunction with such TI products. TI's provision of these resources does not expand or otherwise alter TI's applicable warranties or warranty disclaimers for TI products.

TI objects to and rejects any additional or different terms you may have proposed.

Mailing Address: Texas Instruments, Post Office Box 655303, Dallas, Texas 75265
Copyright © 2024, Texas Instruments Incorporated