

TRF0206-SP Single-Channel, 10-MHz to 6.5-GHz, 3-dB BW, ADC Driver Amplifier

1 Features

- QMLV (QML class V) MIL-PRF-38535 qualified, SMD 5962R2122001VXC
 - Radiation hardness assurance (RHA) up to 100-krad (Si) total ionizing dose (TID)
 - Single event latch-up (SEL) immune to LET = 75 MeV-cm²/mg
- Qualified over the military temperature range of –55°C to +125°C
- Excellent single-ended to differential conversion performance as ADC driver
- Operates in differential-to-single-ended mode to work as a DAC buffer
- 3-dB bandwidth: 6.5 GHz
- 1-dB gain flatness: 4.8 GHz
- Fixed single-ended-to-differential power gain of 12.5 dB
- OIP3 performance:
 - 38 dBm at 2 GHz
 - 32 dBm at 6 GHz
- P1dB performance:
 - 12 dBm at 2 GHz
 - 10 dBm at 6 GHz
- Noise figure:
 - 8 dB at 2 GHz
 - 9 dB at 6 GHz
- Gain and phase imbalance: ±0.4 dB and ±3°
- Power-down feature
- Single-supply operation: 3.3 V
- Active current: 130 mA

2 Applications

- RF sampling or GSPS ADC driver
- [Aerospace and defense](#)
- High-speed digitizers
- [Radar imaging payload](#)
- [Command and data handling systems](#)
- [Communications payload](#)

3 Description

The TRF0206-SP is a very high-performance, radiation-hardened radio-frequency (RF) amplifier optimized for RF applications. This device is an excellent choice for ac-coupled applications that require a single-ended to differential conversion when driving an analog-to-digital converter (ADC) such as the high performance [ADC12DJ3200QML-SP](#). The on-chip matching components simplify printed circuit board (PCB) implementation and provide the highest performance over the usable bandwidth. The device is fabricated using Texas Instruments' advanced complementary BiCMOS process, and is available in a space-qualified, LCCC package.

The device operates on a 3.3-V single-rail supply. A power-down feature is available for power savings.

Device Information

PART NUMBER ⁽¹⁾	GRADE	BODY SIZE ⁽²⁾
5962R2122001VXC	QMLV-RHA	FFM (LCCC, 12-pin) 6.2 mm × 6.1 mm
TRF0206FFM/EM	Engineering samples ⁽³⁾	
TRF0206EVM	Ceramic evaluation board	—

- (1) For all available packages, see the orderable addendum at the end of the data sheet.
- (2) The body size (length × width) is a nominal value and does not include pins.
- (3) These units are intended for engineering evaluation only. These samples are processed to a non-compliant flow. These units are not for qualification, production, radiation testing, or flight use. Parts are not warranted for performance over the full MIL specified temperature range, or operating life.

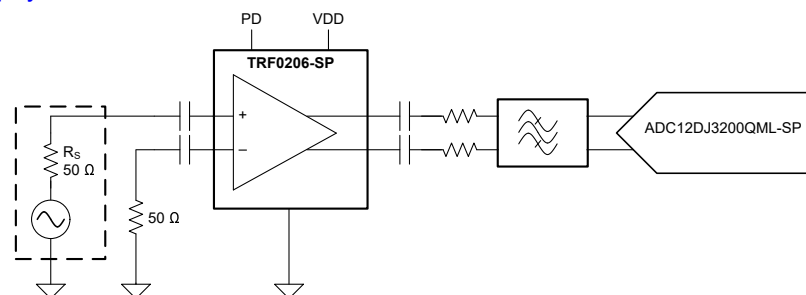

TRF0206-SP Driving a High-Speed ADC



Table of Contents

1 Features	1	7.4 Device Functional Modes.....	14
2 Applications	1	8 Application and Implementation	15
3 Description	1	8.1 Application Information.....	15
4 Revision History	2	8.2 Typical Application.....	17
5 Pin Configuration and Functions	3	8.3 Power Supply Recommendations.....	18
6 Specifications	4	8.4 Layout.....	18
6.1 Absolute Maximum Ratings.....	4	9 Device and Documentation Support	19
6.2 ESD Ratings.....	4	9.1 Device Support.....	19
6.3 Recommended Operating Conditions.....	4	9.2 Documentation Support	19
6.4 Thermal Information.....	4	9.3 Receiving Notification of Documentation Updates...	19
6.5 Electrical Characteristics.....	5	9.4 Support Resources.....	19
6.6 Quality Conformance Inspection.....	7	9.5 Trademarks.....	19
6.7 Typical Characteristics.....	8	9.6 Electrostatic Discharge Caution.....	19
7 Detailed Description	13	9.7 Glossary.....	19
7.1 Overview.....	13	10 Mechanical, Packaging, and Orderable	
7.2 Functional Block Diagram.....	13	Information	19
7.3 Feature Description.....	14		

4 Revision History

NOTE: Page numbers for previous revisions may differ from page numbers in the current version.

Changes from Revision A (December 2022) to Revision B (August 2023)	Page
• Added new orderable part numbers to the <i>Device Information</i> table.....	1

Changes from Revision * (November 2022) to Revision A (December 2022)	Page
• Changed the status from: <i>Advanced Information</i> to: <i>Production Data</i>	1

5 Pin Configuration and Functions

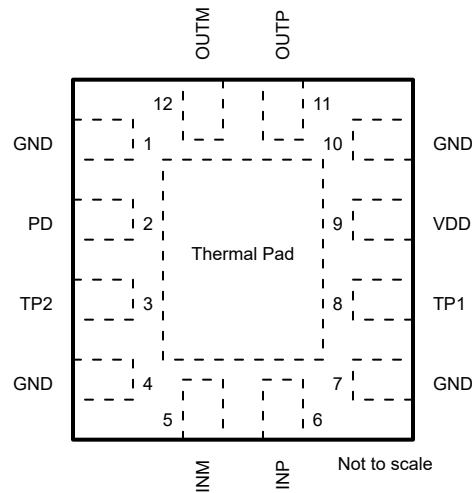

Figure 5-1. FFM Package, 12-Pin LCCC (Top View)

Table 5-1. Pin Functions

PIN		TYPE ⁽¹⁾	DESCRIPTION
NAME	NO.		
GND	1, 4, 7, 10	GND	Ground
INM	5	I	Differential signal input, negative
INP	6	I	Differential signal input, positive
OUTM	12	O	Differential signal output, negative
OUTP	11	O	Differential signal output, positive
PD	2	I	Power down signal. Supports 1.8-V and 3.3-V Logic. 0 = chip enabled 1 = power down
TP1	8	—	Test pin. Short to ground.
TP2	3	—	Test pin. Short to ground.
VDD	9	P	3.3-V supply
Thermal Pad	pad	—	Thermal pad. Connect to ground on board.

(1) I = input, O = output, P = power, GND = Ground

6 Specifications

6.1 Absolute Maximum Ratings

over operating free-air temperature range (unless otherwise noted)⁽¹⁾

		MIN	MAX	UNIT
V _{DD}	Supply voltage	-0.3	3.7	V
INP, INM	Input pin power		20	dBm
V _{PD}	Power-down pin voltage	-0.3	3.7	V
T _J	Junction temperature		150	°C
T _{stg}	Storage temperature	-65	150	°C
	Continuous power dissipation	See thermal information		

- (1) Operation outside the Absolute Maximum Ratings may cause permanent device damage. Absolute Maximum Ratings do not imply functional operation of the device at these or any other conditions beyond those listed under Recommended Operating Conditions. If briefly operating outside the Recommended Operating Conditions but within the Absolute Maximum Ratings, the device may not sustain damage, but it may not be fully functional. Operating the device in this manner may affect device reliability, functionality, performance, and shorten the device lifetime.

6.2 ESD Ratings

			VALUE	UNIT
V _(ESD)	Electrostatic discharge	Human body model (HBM), per ANSI/ESDA/ JEDEC JS-001, all pins ⁽¹⁾	±1000	V
		Charged device model (CDM), per ANSI/ESDA/ JEDEC JS-002, all pins ⁽²⁾	±250	

- (1) JEDEC document JEP155 states that 500-V HBM allows safe manufacturing with a standard ESD control process.
(2) JEDEC document JEP157 states that 250-V CDM allows safe manufacturing with a standard ESD control process.

6.3 Recommended Operating Conditions

over operating free-air temperature range (unless otherwise noted)

		MIN	NOM	MAX	UNIT
V _{DD}	Supply voltage	3.2	3.3	3.45	V
T _A	Ambient air temperature	-55	25		°C
T _J	Junction temperature			125	°C

6.4 Thermal Information

THERMAL METRIC ⁽¹⁾		TRF0206-SP	UNIT
		FFM (LCCC)	
		12 PINS	
R _{θJA}	Junction-to-ambient thermal resistance	69.3	°C/W
R _{θJC(top)}	Junction-to-case (top) thermal resistance	54.5	°C/W
R _{θJB}	Junction-to-board thermal resistance	44.4	°C/W
Ψ _{JT}	Junction-to-top characterization parameter	42	°C/W
Ψ _{JB}	Junction-to-board characterization parameter	44.5	°C/W
R _{θJC(bot)}	Junction-to-case (bottom) thermal resistance	36.7	°C/W

- (1) For more information about traditional and new thermal metrics, see the [Semiconductor and IC Package Thermal Metrics](#) application report.

6.5 Electrical Characteristics

Specifications correspond to the respectively identified subgroup temperature, unless otherwise noted. Test conditions at $T_A = 25^\circ\text{C}$, $V_{DD} = 3.3\text{ V}$, single-ended input with $R_S = 50\ \Omega$, differential output with $Z_L = 100\ \Omega$, unless otherwise noted.

PARAMETER		TEST CONDITIONS	SUBGROUP ⁽¹⁾	MIN	TYP	MAX	UNIT
AC PERFORMANCE							
SSBW	Small-signal 3-dB bandwidth	$V_o = 100\text{ mV}_{PP}$			6.5		GHz
LSBW	Large-signal 3-dB bandwidth	$V_o = 1\text{ V}_{PP}$			6.5		GHz
	Bandwidth for 1.5-dB flatness				4.8		GHz
S_{21}	Power gain	$f = 2\text{ GHz}$			12.5		dB
S_{11}	Input return loss	$f = 10\text{ MHz to }4\text{ GHz}$			-10		dB
S_{12}	Reverse isolation	$f = 10\text{ MHz to }4\text{ GHz}$			-35		dB
	Gain imbalance	$f = 10\text{ MHz to }5\text{ GHz}$			± 0.4		dB
	Phase imbalance	$f = 10\text{ MHz to }5\text{ GHz}$			± 3		$^\circ$
CMRR	Common-mode rejection ratio ⁽²⁾	$f = 2\text{ GHz}$			-30		dB
HD2	Second-order harmonic distortion	$f = 0.5\text{ GHz}, P_o = +2\text{ dBm}$			-65		dBc
		$f = 1\text{ GHz}, P_o = +2\text{ dBm}$			-60		
		$f = 2\text{ GHz}, P_o = +2\text{ dBm}$			-60		
		$f = 4\text{ GHz}, P_o = +2\text{ dBm}$			-60		
HD3	Third-order harmonic distortion	$f = 0.5\text{ GHz}, P_o = +2\text{ dBm}$			-65		dBc
		$f = 1\text{ GHz}, P_o = +2\text{ dBm}$			-65		
		$f = 2\text{ GHz}, P_o = +2\text{ dBm}$			-68		
		$f = 4\text{ GHz}, P_o = +2\text{ dBm}$			-58		
OP1dB	Output 1-dB compression point	$f = 0.5\text{ GHz}$			8.5		dBm
		$f = 1\text{ GHz}$			10		
		$f = 2\text{ GHz}$			12		
		$f = 4\text{ GHz}$			10.5		
		$f = 6\text{ GHz}$			10		
OIP2	Output second-order intercept point	$f = 0.5\text{ GHz}, P_o = -5\text{ dBm per tone}, 10\text{ MHz spacing}$			65		dBm
		$f = 1\text{ GHz}, P_o = -5\text{ dBm per tone}, 10\text{ MHz spacing}$			62		
		$f = 2\text{ GHz}, P_o = -5\text{ dBm per tone}, 10\text{ MHz spacing}$			58		
		$f = 4\text{ GHz}, P_o = -5\text{ dBm per tone}, 10\text{ MHz spacing}$			55		
		$f = 6\text{ GHz}, P_o = -5\text{ dBm per tone}, 10\text{ MHz spacing}$			55		
OIP3	Output third-order intercept point	$f = 0.5\text{ GHz}, P_o = -5\text{ dBm per tone}, 10\text{ MHz spacing}$			32		dBm
		$f = 1\text{ GHz}, P_o = -5\text{ dBm per tone}, 10\text{ MHz spacing}$			35		
		$f = 2\text{ GHz}, P_o = -5\text{ dBm per tone}, 10\text{ MHz spacing}$			38		
		$f = 4\text{ GHz}, P_o = -5\text{ dBm per tone}, 10\text{ MHz spacing}$			35		
		$f = 6\text{ GHz}, P_o = -5\text{ dBm per tone}, 10\text{ MHz spacing}$			32		

6.5 Electrical Characteristics (continued)

Specifications correspond to the respectively identified subgroup temperature, unless otherwise noted. Test conditions at $T_A = 25^\circ\text{C}$, $V_{DD} = 3.3\text{ V}$, single-ended input with $R_S = 50\ \Omega$, differential output with $Z_L = 100\ \Omega$, unless otherwise noted.

PARAMETER		TEST CONDITIONS	SUBGROUP ⁽¹⁾	MIN	TYP	MAX	UNIT
NF	Noise figure	f = 0.5 GHz			7.5		dB
		f = 1 GHz			7.5		
		f = 2 GHz			8		
		f = 4 GHz			9		
		f = 6 GHz			9		
IMPEDANCE							
Z_{O-DIFF}	Differential output impedance	f = dc (internal to the device)			5		Ω
Z_{IN}	Single-ended input impedance	With INM terminated with 50 Ω			50		Ω
TRANSIENT							
V_{OMAX}	Output max operating voltage (differential)				1.7		V_{PP}
V_{OSAT}	Output saturated voltage level (differential)	f = 4 GHz			3.5		V_{PP}
T_{REC}	Over-drive recovery time	Using a 0.5- V_P input pulse of 2-ns duration			0.35		ns
POWER SUPPLY							
I_{QA}	Active current	Current on VDD pin, PD = 0	[1, 2, 3]	85	130	170	mA
I_{QPD}	Power-down quiescent current	Current on VDD pin, PD = 1	[1, 2, 3]	2	7	16	mA
ENABLE							
V_{PDHIGH}	PD pin logic high			1.55			V
V_{PDLLOW}	PD pin logic low					0.7	V
I_{PDBIAS}	PD bias current (current on PD pin)	PD = high (1.8-V logic)			50	100	μA
		PD = low (3.3-V logic)			200	300	
C_{PD}	PD pin capacitance				3		pF
T_{ON}	Turn-on time	50% V_{PD} to 90% RF			200		ns
T_{OFF}	Turn-off time	50% V_{PD} to 10% RF			100		ns

(1) For subgroup definitions, please see [Quality Conformance Inspection](#).

(2) CMRR is calculated using the formula $(S21-S31) / (S21+S31)$. Port-1: INP, Port-2: OUTP, Port-3: OUTM.

6.6 Quality Conformance Inspection

SUBGROUP ⁽¹⁾	DESCRIPTION	TEMPERATURE (°C)
1	Static tests at	25
2	Static tests at	125
3	Static tests at	-55
4	Dynamic tests at	25
5	Dynamic tests at	125
6	Dynamic tests at	-55
7	Functional tests at	25
8A	Functional tests at	125
8B	Functional tests at	-55
9	Switching tests at	25
10	Switching tests at	125
11	Switching tests at	-55

(1) MIL-STD-883, Method 5005 – Group A

6.7 Typical Characteristics

at $T_A = 25^\circ\text{C}$, $V_{DD} = 3.3\text{ V}$, single-ended input with $R_S = 50\ \Omega$, differential output with $Z_L = 100\ \Omega$ (unless otherwise noted)

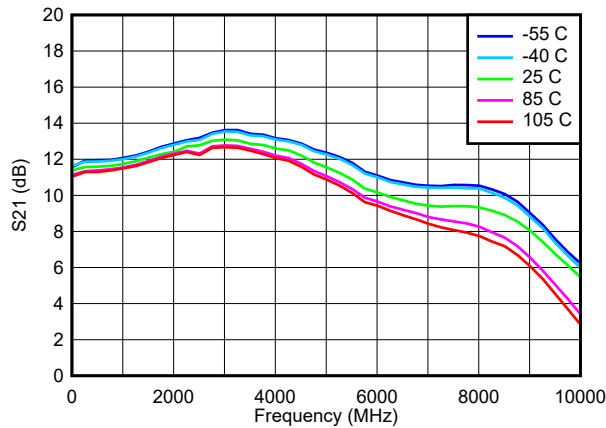

Figure 6-1. Power Gain Across Temperature

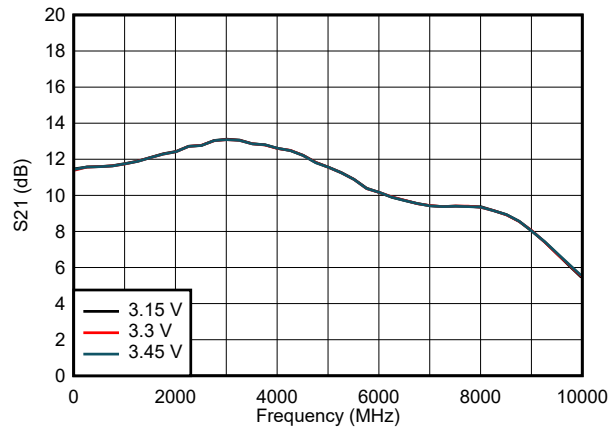

Figure 6-2. Power Gain Across VDD

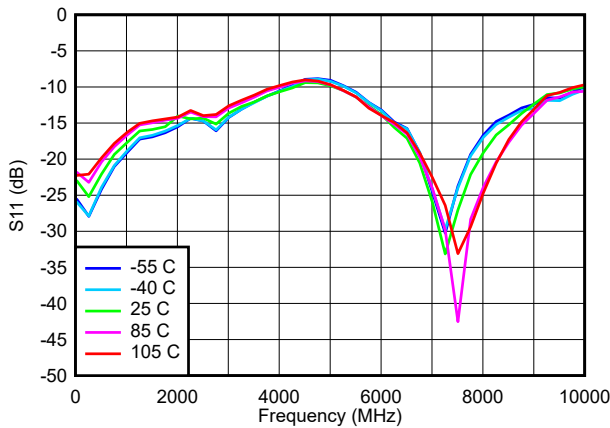

Figure 6-3. Return Loss Across Temperature

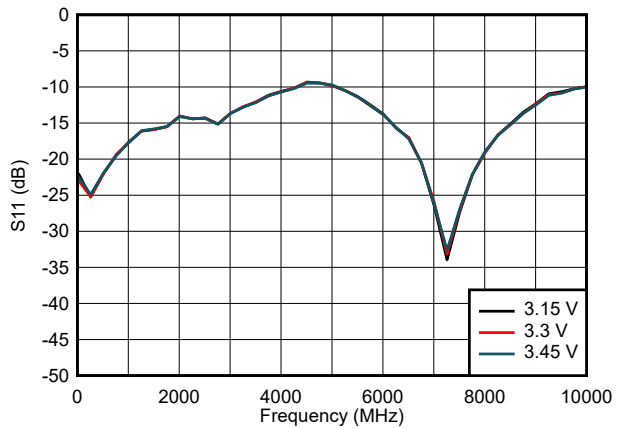

Figure 6-4. Return Loss Across VDD

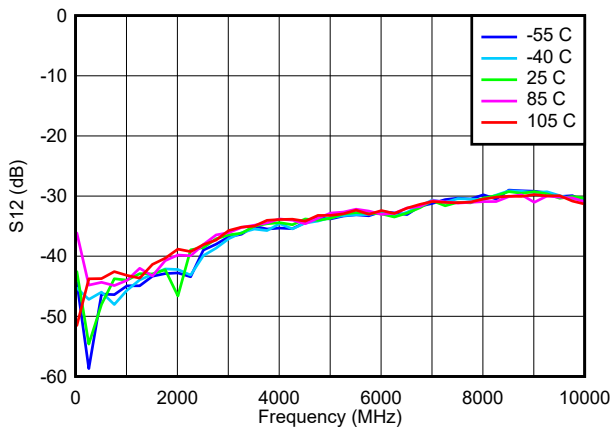

Figure 6-5. Reverse Isolation Across Temperature

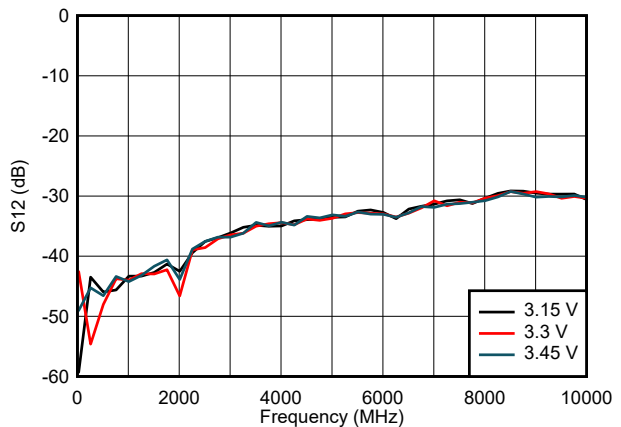
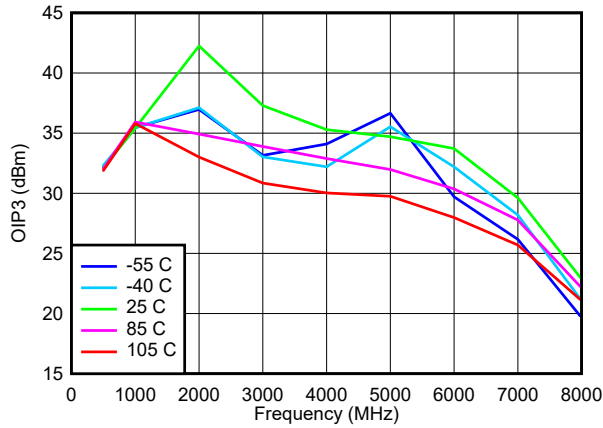

Figure 6-6. Reverse Isolation Across VDD

6.7 Typical Characteristics (continued)

at $T_A = 25^\circ\text{C}$, $V_{DD} = 3.3\text{ V}$, single-ended input with $R_S = 50\ \Omega$, differential output with $Z_L = 100\ \Omega$ (unless otherwise noted)



Put / tone = -5 dBm, 10-MHz tone spacing

Figure 6-7. OIP3 Across Temperature

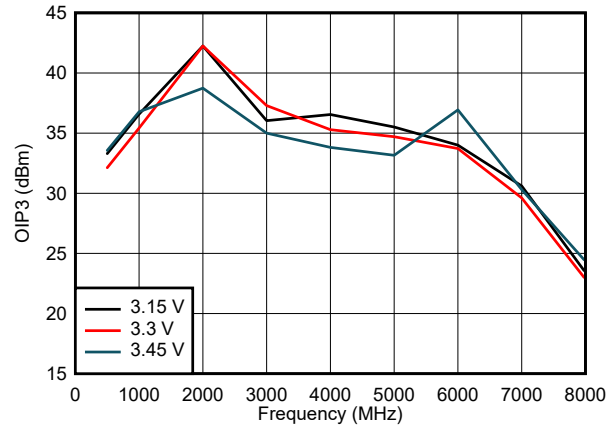

Put / tone = -5 dBm, 10-MHz tone spacing

Figure 6-8. OIP3 Across VDD

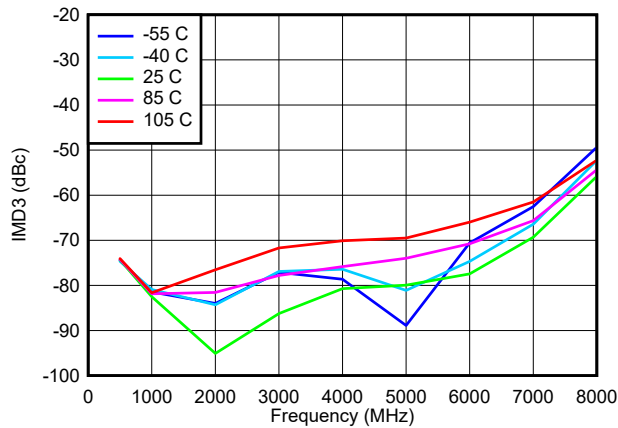

At $(2f_1 - f_2)$ frequency; $f_2 > f_1$, Put / tone = -5 dBm, 10-MHz tone spacing

Figure 6-9. IMD3 Lower Frequency

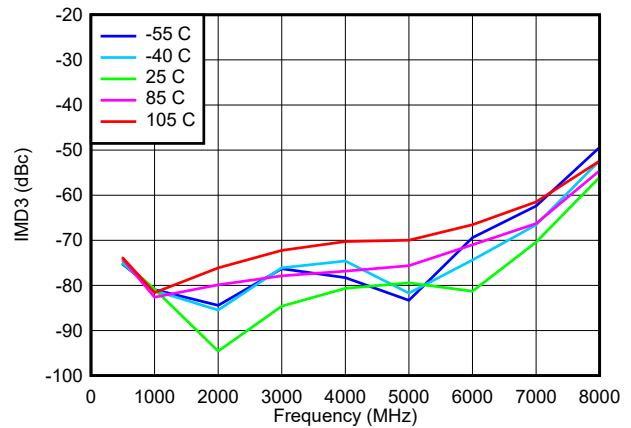

At $(2f_2 - f_1)$ frequency; $f_2 > f_1$, Put / tone = -5 dBm, 10-MHz tone spacing

Figure 6-10. IMD3 Higher Frequency

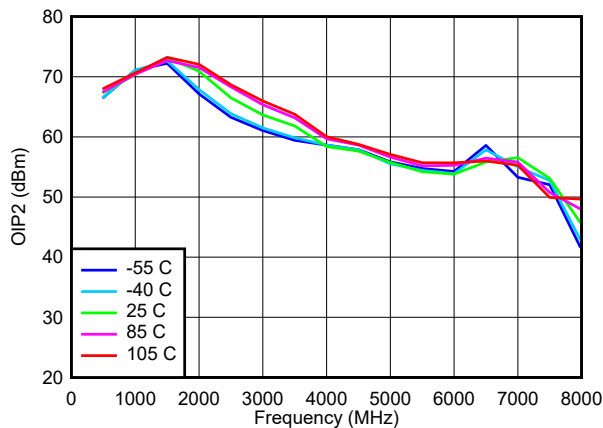

At $(f_2 - f_1)$ frequency; $f_2 > f_1$, Put / tone = -5 dBm, 10-MHz tone spacing

Figure 6-11. OIP2 Lower Frequency Across Temperature

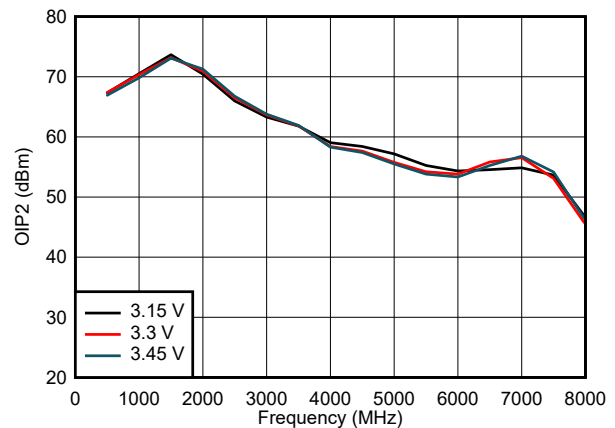

At $(f_2 - f_1)$ frequency; $f_2 > f_1$, Put / tone = -5 dBm, 10-MHz tone spacing

Figure 6-12. OIP2 Lower Frequency Across VDD

6.7 Typical Characteristics (continued)

at $T_A = 25^\circ\text{C}$, $V_{DD} = 3.3\text{ V}$, single-ended input with $R_S = 50\ \Omega$, differential output with $Z_L = 100\ \Omega$ (unless otherwise noted)

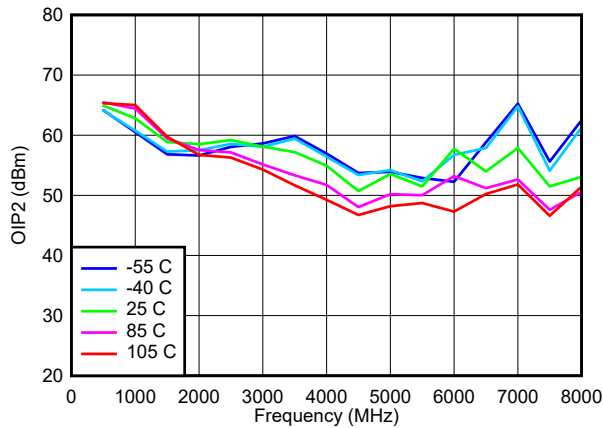

At (f_2+f_1) frequency; $f_2 > f_1$, P_{out} / tone = -5 dBm ,
10-MHz tone spacing

Figure 6-13. OIP2 Higher Frequency Across Temperature

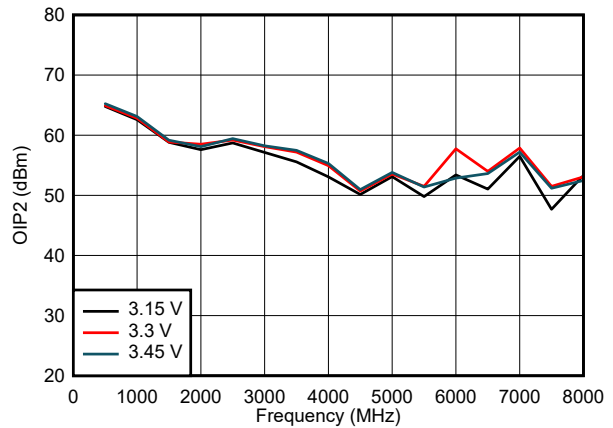

At (f_2+f_1) frequency; $f_2 > f_1$, P_{out} / tone = -5 dBm ,
10-MHz tone spacing

Figure 6-14. OIP2 Higher Frequency Across VDD

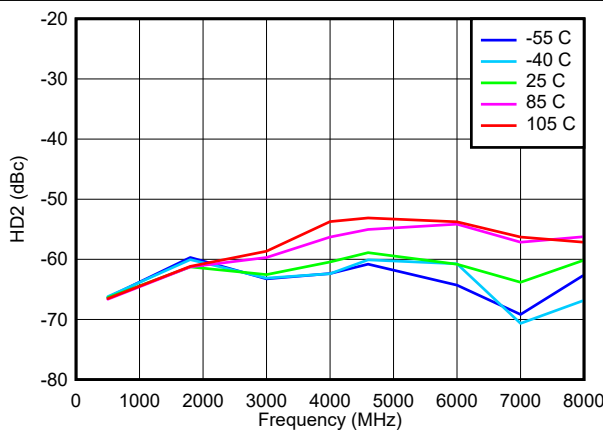

$P_{out} = +2\text{ dBm}$

Figure 6-15. HD2 Across Temperature

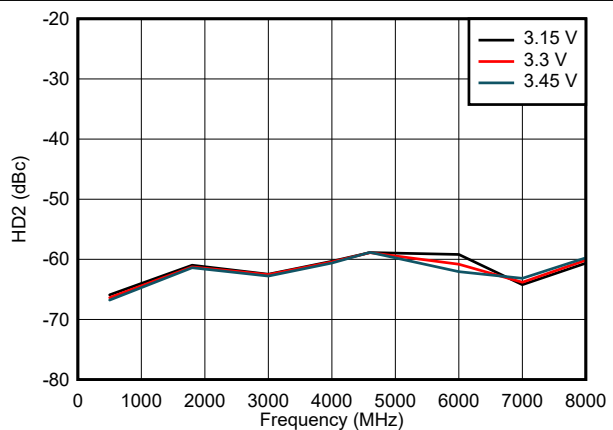

$P_{out} = +2\text{ dBm}$

Figure 6-16. HD2 Across VDD

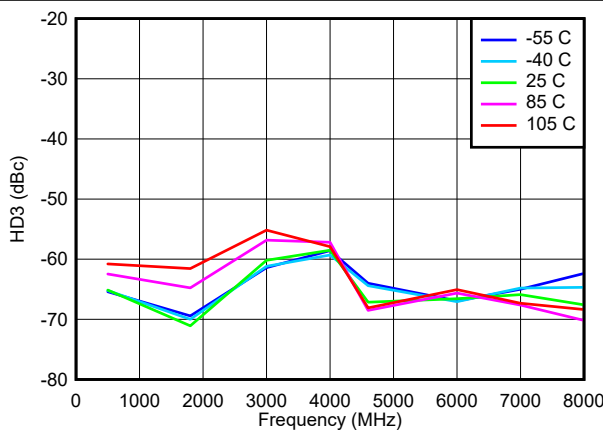

$P_{out} = +2\text{ dBm}$

Figure 6-17. HD3 Across Temperature

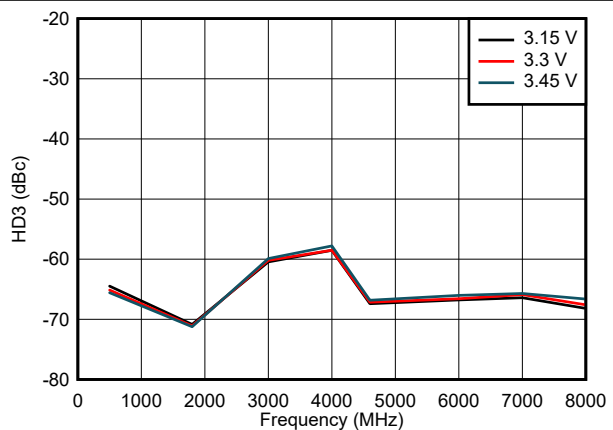

$P_{out} = +2\text{ dBm}$

Figure 6-18. HD3 Across VDD

6.7 Typical Characteristics (continued)

at $T_A = 25^\circ\text{C}$, $V_{DD} = 3.3\text{ V}$, single-ended input with $R_S = 50\ \Omega$, differential output with $Z_L = 100\ \Omega$ (unless otherwise noted)

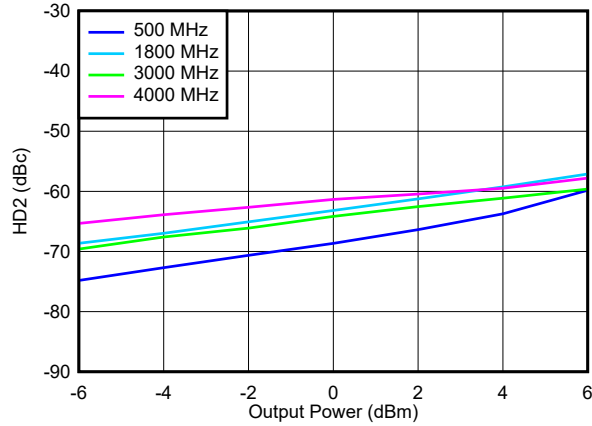

Figure 6-19. HD2 vs Output Power

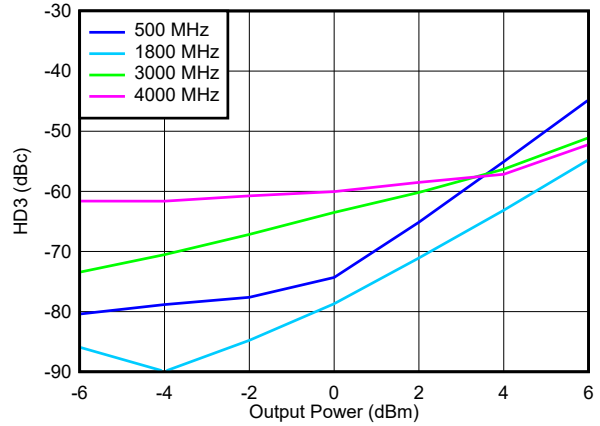

Figure 6-20. HD3 vs Output Power

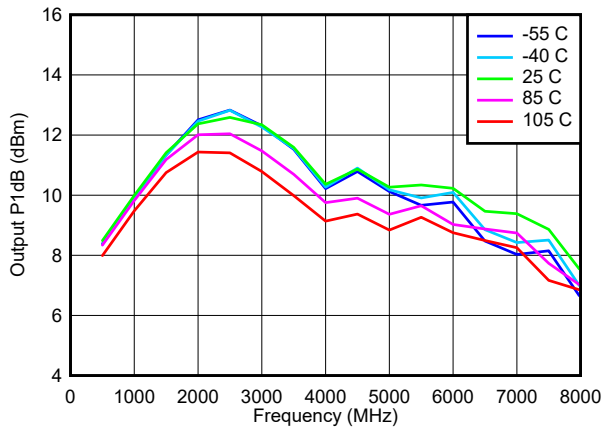

Figure 6-21. Output P1 dB Across Temperature

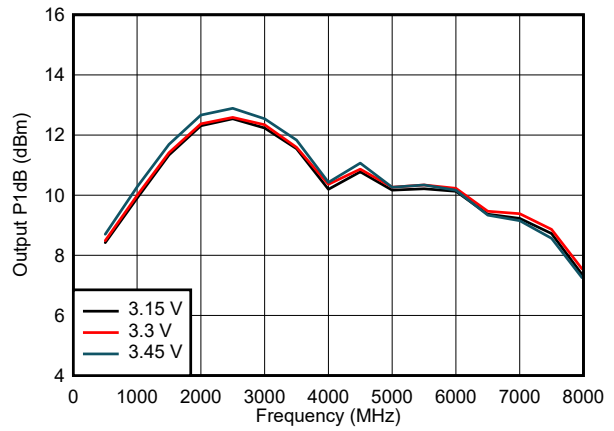

Figure 6-22. Output P1 dB Across VDD

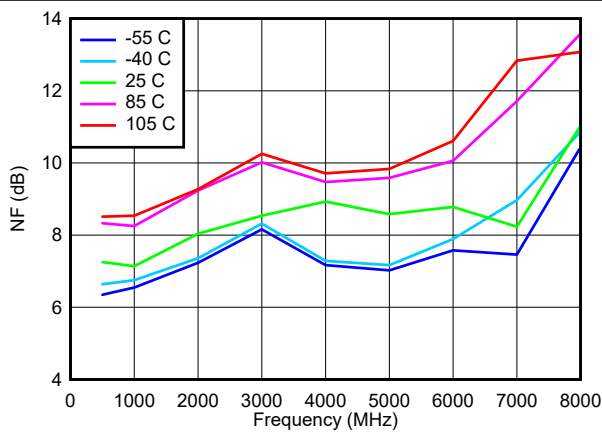

Figure 6-23. NF Across Temperature

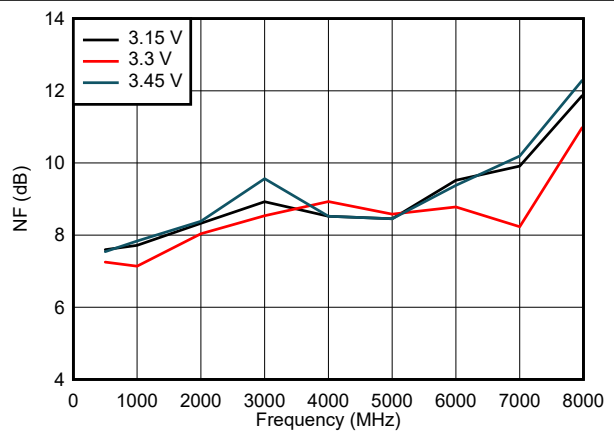

Figure 6-24. NF Across VDD

6.7 Typical Characteristics (continued)

at $T_A = 25^\circ\text{C}$, $V_{DD} = 3.3\text{ V}$, single-ended input with $R_S = 50\ \Omega$, differential output with $Z_L = 100\ \Omega$ (unless otherwise noted)

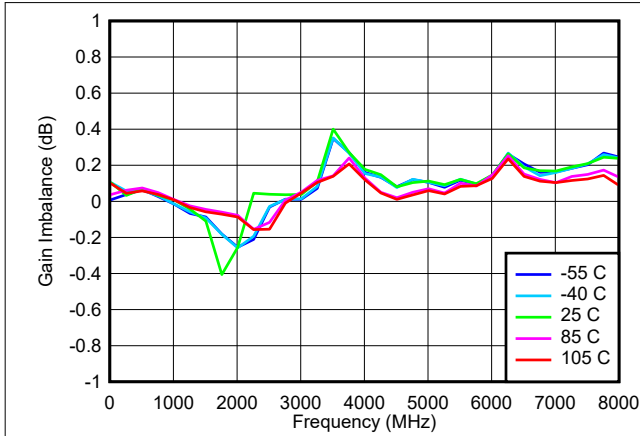

Figure 6-25. Gain Imbalance

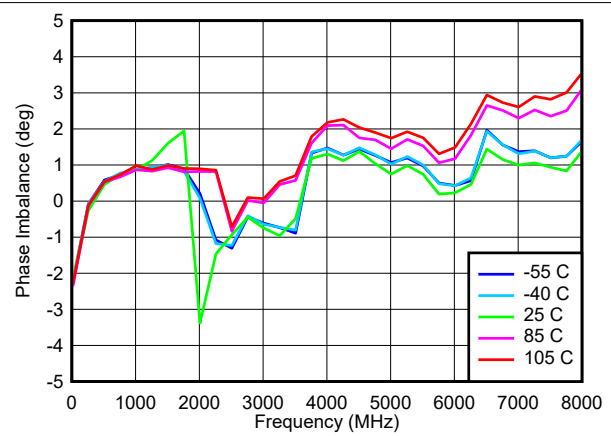

Figure 6-26. Phase Imbalance

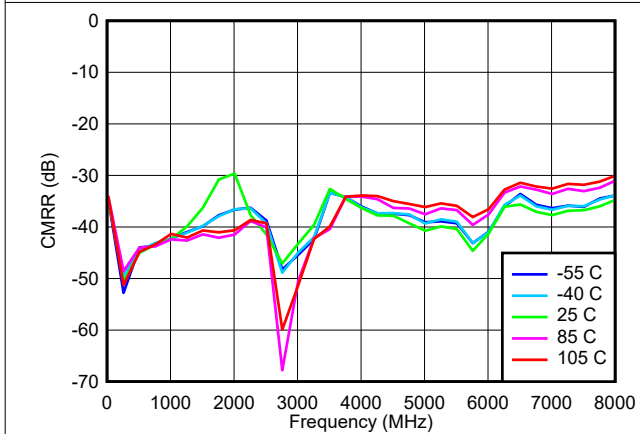

Figure 6-27. CMRR Across Temperature

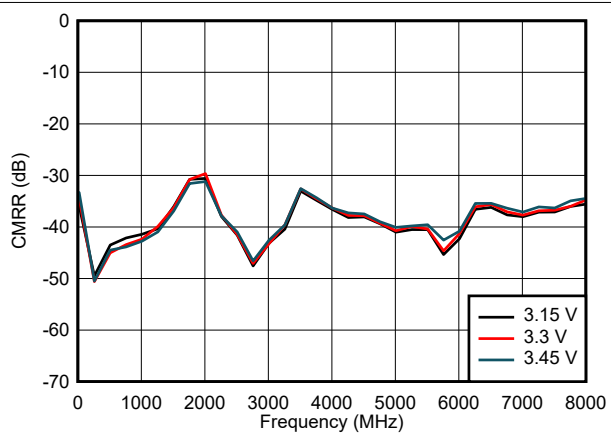

Figure 6-28. CMRR Across VDD

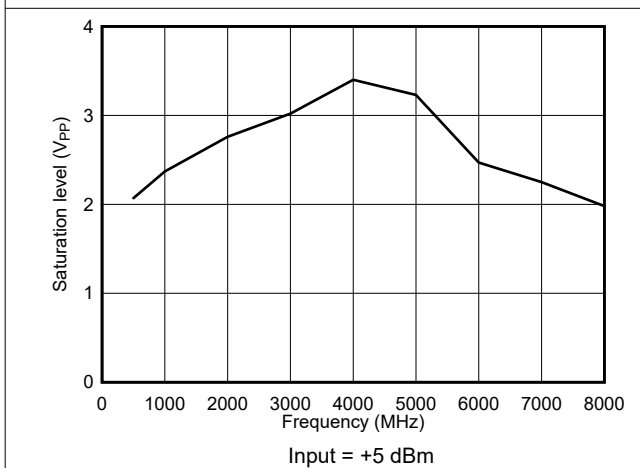

Figure 6-29. Saturation Voltage

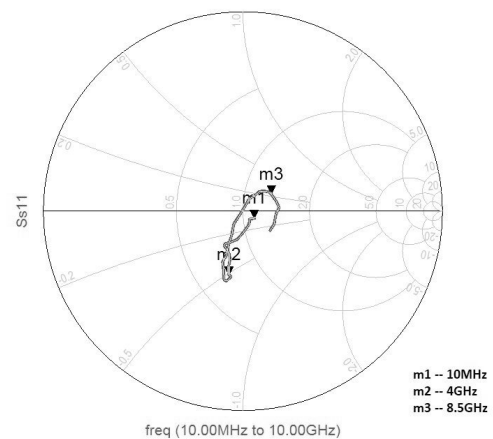

Figure 6-30. Single-Ended S11

7 Detailed Description

7.1 Overview

The TRF0206-SP is a very high-performance amplifier optimized for radio frequency (RF) and intermediate frequency (IF) with signal bandwidths up to 7 GHz. This device is an excellent choice for ac-coupled applications that require a single-ended to differential conversion when driving an analog-to-digital converter (ADC). The device has a two-stage architecture and provides approximately 13 dB of gain when configured for single-ended inputs driven from a 50-Ω source. This device also works as a differential-to-single-ended amplifier to act as a DAC buffer.

This TRF0206-SP does not require any pullup or pulldown components on the PCB, and thereby simplifies the layout and provides the highest performance over the whole bandwidth.

The input and output are ac coupled. The device is powered with 3.3-V supply. A power-down feature is also available.

7.2 Functional Block Diagram

The following figure shows the functional block diagram of the TRF0206-SP. The device essentially has two stages with a voltage-feedback configuration.

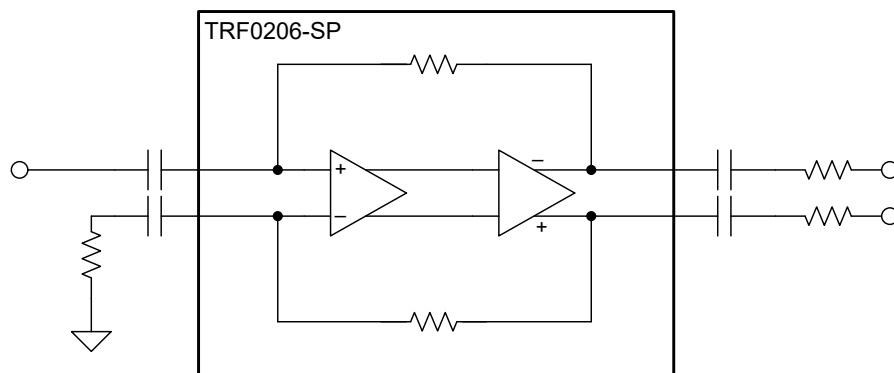

7.3 Feature Description

7.3.1 Fully Differential Amplifier

The TRF0206-SP is a voltage-feedback fully differential amplifier (FDA) with a fixed gain by architecture. The TRF0206-SP operates best as a single-ended to differential amplifier by terminating the INM pin with a 50- Ω resistor and driving the INP pin directly with no external components.

This amplifier has nonlinearity cancellation circuits that provide excellent linearity performance over a wide range of frequencies.

The output of the amplifier has a low dc impedance. Therefore, if required, the output of the amplifier can be matched to a load by adding appropriate series resistors or attenuator pad.

7.3.2 Single-Supply Operation

The TRF0206-SP operates on a single, 3.3-V supply. The input and output bias voltages are set internally. Therefore, ac-couple the signal path on the board at all four RF input and output pins. Single-supply operation simplifies the board design.

7.4 Device Functional Modes

The TRF0206-SP has two functional modes: active and power-down. These functional modes are controlled by the PD pin as described in the previous section.

7.4.1 Power-Down Mode

The device features a power-down option. The PD pin is used to power down the amplifier. This pin supports both 1.8-V and 3.3-V digital logic, and is referenced to ground. A logic 1 turns the device off and places the device into a low-quiescent-current state.

When disabled, the signal path is still present through the internal circuits. Input signals applied to a disabled device still appear at the outputs at some lower level through this path, as is the case for any disabled feedback amplifier.

8 Application and Implementation

Note

Information in the following applications sections is not part of the TI component specification, and TI does not warrant its accuracy or completeness. TI's customers are responsible for determining suitability of components for their purposes, as well as validating and testing their design implementation to confirm system functionality.

8.1 Application Information

8.1.1 Driving a High-Speed ADC

A common application of the TRF0206-SP is to drive a high-speed ADC, such as the [ADC12DJ3200QML-SP](#) or [AFE7950](#) that have differential inputs. Conventionally, passive baluns are used to drive GSPS ADCs because of nonavailability of high-bandwidth linear amplifiers. The TRF0206-SP is an active balun that has excellent bandwidth flatness, gain, and phase imbalance comparable to or exceeding costly passive baluns.

The following figure shows a typical interface circuit for the ADC12DJ3200QML-SP. Depending on the ADC and system requirement, this circuit can be simplified or can be more complex.

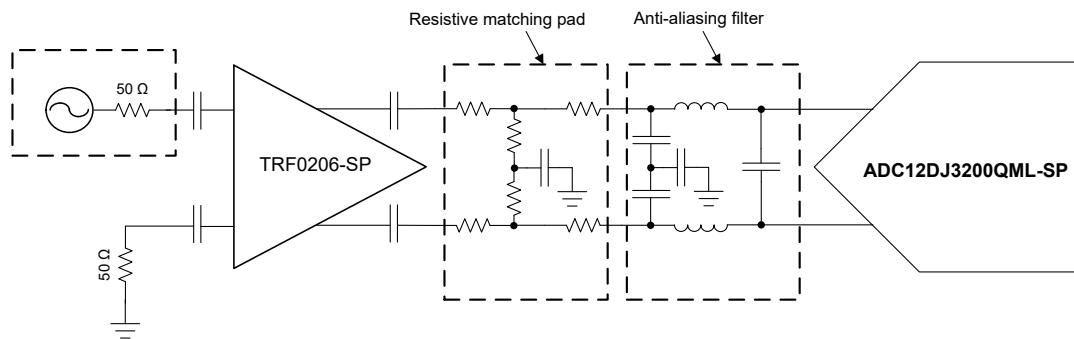

Figure 8-1. Interfacing with High-Speed ADC

Figure 8-1 shows two sections of the circuit between the driver amp and the ADC: namely, the matching pad (or attenuator pad) and the antialiasing filter. Use small form-factor, RF-quality, passive components for these circuits. The output swing of the TRF0206-SP is designed to drive these ADCs full-scale, while at the same time not overdrive the device. This functionality avoids the need for any voltage limiting device at the ADC.

8.1.2 Calculating Output Voltage Swing

This section gives a quick reference of the output voltage swings for different input power levels. In this example, the output is terminated with a 100-Ω differential load and a power gain of 13 dB is assumed.

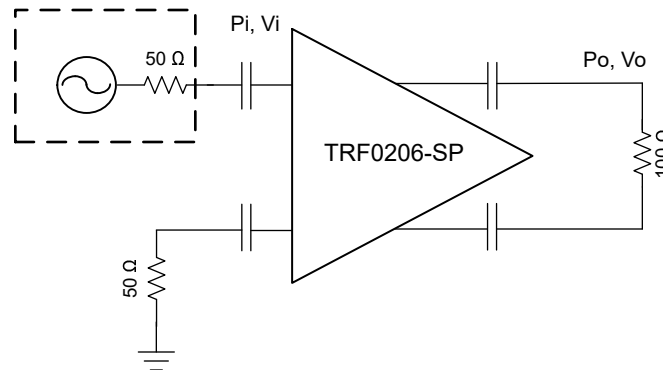

Figure 8-2. Power and Voltage Levels

$$\text{Voltage gain} = 20 \times \log(V_o / V_i) \quad (1)$$

$$\text{Power gain} = 10 \times \log(P_o / P_i) = 10 \times \log((V_o^2 / 100) / (V_i^2 / 50)) = 20 \times \log(V_o / V_i) - 3 \text{ dB} \quad (2)$$

Table 8-1. Output Voltage Swings for Different Input Power Levels

INPUT		OUTPUT	
P _i (dBm)	V _i (V _{PP})	P _o (dBm)	V _o (V _{PP})
-20	0.063	-7	0.4
-15	0.112	-2	0.71
-10	0.2	3	1.263
-7	0.283	6	1.785

8.1.3 Thermal Considerations

The TRF0206-SP is packaged in a 6.10 mm × 6.20 mm LCCC-FC package that has excellent thermal properties. Connect the device thermal pad to a ground plane. Short the ground plane to the other ground pins of the device at four corners, if possible, to allow heat propagation to the top layer of the PCB. Use a thermal via that connects the thermal pad plane on the top layer of the PCB to the inner layer ground planes to allow heat propagation to the inner layers.

Limit the total power dissipation to keep the device junction temperature less than 150°C for instantaneous power and less than 125°C for continuous power.

8.2 Typical Application

8.2.1 TRF0206-SP Driving an AFE7950-SP Receiver

This section describes an RF receiver chain in which the TRF0206-SP is working as a single-ended to differential (S2D) amplifier and driving a receive channel of the AFE7950-SP.

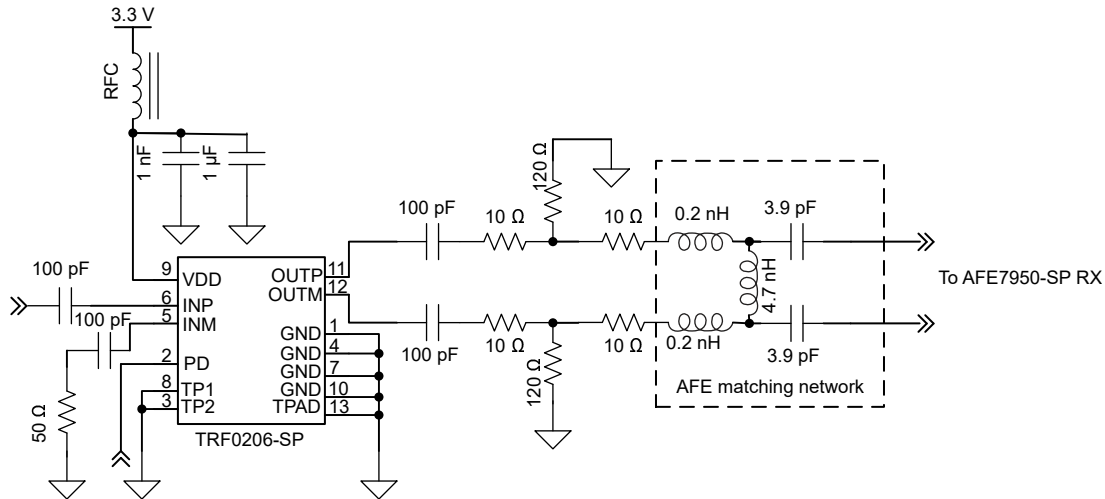

Figure 8-3. The TRF0206-SP in a Receive Chain Driving the AFE7950-SP ADC

Figure 8-3 is a generic schematics of a design in which the TRF0206-SP drives an AFE7950-SP receive channel. The exact values of the components depend on the frequency band for which the AFE7950-SP front-end is matched.

8.2.1.1 Design Requirements

The AFE7950-SP receive channel is required to be matched to 2.3 GHz.

8.2.1.2 Detailed Design Procedure

The TRF0206-SP is configured as an S2D amplifier. The section close to the TRF0206-SP output is an attenuator pad that is meant for robust matching. The section close to AFE7950-SP is the matching network for the AFE that is channel and channel-frequency dependent. The matching components are chosen based on the AFE return-loss data and some trial and error because the manufactured board parameters can influence the exact component values.

8.3 Power Supply Recommendations

The TRF0206-SP requires a single 3.3-V supply. Supply decoupling is critical to high-frequency performance. Typically two or three capacitors are used for supply decoupling. Place the lowest-value capacitor, a small form-factor component, closest to the VDD pin of the device. Place a bulk decoupling capacitor that has a larger value and size next to the small capacitor. Additional layout recommendations are given in the *Layout* section.

8.4 Layout

8.4.1 Layout Guidelines

TRF0206-SP is a wide-band feedback amplifier with approximately 13 dB of gain. When designing with a wideband RF amplifier with relatively high gain, take certain board layout precautions to maintain stability and optimal performance. Use a multilayered board to maintain signal and power integrity and thermal performance. The following figure shows an example of a good layout. In this figure, only the top layer is shown.

Route the RF input and output lines as grounded coplanar waveguide (GCPW) lines. Make sure the second layer is a continuous ground layer without any ground-cuts near the amplifier area. Match the output differential lines in length to minimize phase imbalance. Use small footprint passive components wherever possible. Also take care of the input side layout. Route the INP with a 50- Ω line. Make sure that the NM pin termination has low parasitics by placing the ac-coupling capacitor and the 50- Ω resistor very close to the device. Use an RF quality 50- Ω resistor for termination. Make sure that ground planes on the top and internal layers are well stitched with vias.

As [Figure 8-4](#) shows, place thermal vias under the device that connect the top thermal pad with ground planes in the inner layers of the PCB. Also connect the thermal pad to the top layer ground plane through the ground pins.

8.4.2 Layout Example

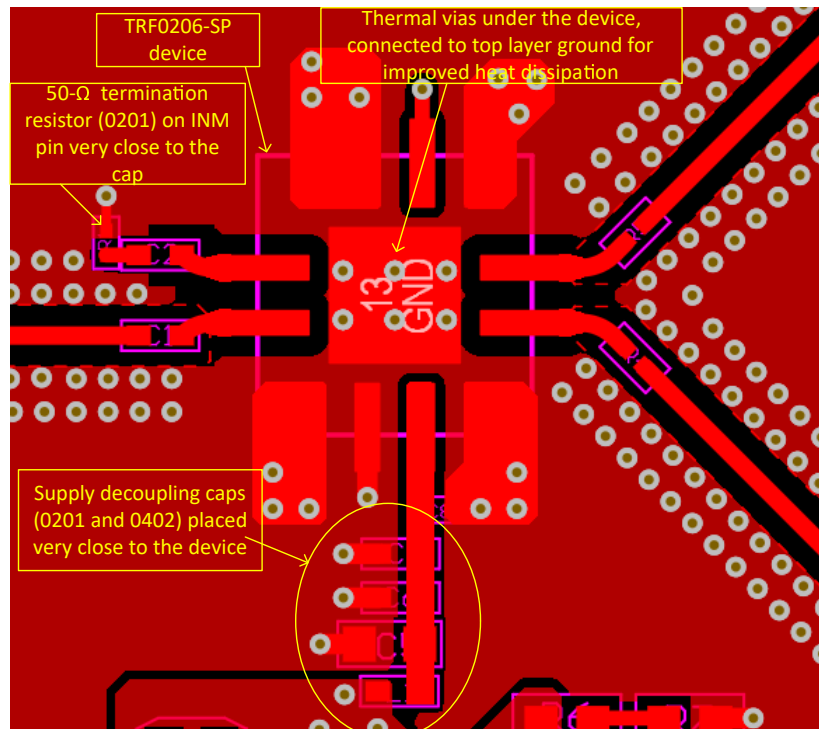

Figure 8-4. Layout Example: Placement and Top Layer Layout

The TRF0206-SP can be evaluated using the TRF0206-SP EVM board, which can be ordered from the [TRF0206-SP product folder](#). Additional information about the evaluation board construction and test setup is given in the [TRF0206-SP EVM User's Guide](#).

9 Device and Documentation Support

9.1 Device Support

9.1.1 Third-Party Products Disclaimer

TI'S PUBLICATION OF INFORMATION REGARDING THIRD-PARTY PRODUCTS OR SERVICES DOES NOT CONSTITUTE AN ENDORSEMENT REGARDING THE SUITABILITY OF SUCH PRODUCTS OR SERVICES OR A WARRANTY, REPRESENTATION OR ENDORSEMENT OF SUCH PRODUCTS OR SERVICES, EITHER ALONE OR IN COMBINATION WITH ANY TI PRODUCT OR SERVICE.

9.2 Documentation Support

9.2.1 Related Documentation

For related documentation, see the following:

- Texas Instruments, [TRF0206-SP EVM User's Guide](#)

9.3 Receiving Notification of Documentation Updates

To receive notification of documentation updates, navigate to the device product folder on [ti.com](#). Click on *Subscribe to updates* to register and receive a weekly digest of any product information that has changed. For change details, review the revision history included in any revised document.

9.4 Support Resources

[TI E2E™ support forums](#) are an engineer's go-to source for fast, verified answers and design help — straight from the experts. Search existing answers or ask your own question to get the quick design help you need.

Linked content is provided "AS IS" by the respective contributors. They do not constitute TI specifications and do not necessarily reflect TI's views; see TI's [Terms of Use](#).

9.5 Trademarks

TI E2E™ is a trademark of Texas Instruments.

All trademarks are the property of their respective owners.

9.6 Electrostatic Discharge Caution



This integrated circuit can be damaged by ESD. Texas Instruments recommends that all integrated circuits be handled with appropriate precautions. Failure to observe proper handling and installation procedures can cause damage.

ESD damage can range from subtle performance degradation to complete device failure. Precision integrated circuits may be more susceptible to damage because very small parametric changes could cause the device not to meet its published specifications.

9.7 Glossary

[TI Glossary](#) This glossary lists and explains terms, acronyms, and definitions.

10 Mechanical, Packaging, and Orderable Information

The following pages include mechanical, packaging, and orderable information. This information is the most current data available for the designated devices. This data is subject to change without notice and revision of this document. For browser-based versions of this data sheet, refer to the left-hand navigation.

PACKAGING INFORMATION

Orderable Device	Status (1)	Package Type	Package Drawing	Pins	Package Qty	Eco Plan (2)	Lead finish/ Ball material (6)	MSL Peak Temp (3)	Op Temp (°C)	Device Marking (4/5)	Samples
5962R2122001VXC	ACTIVE	LCCC	FFM	12	50	Non-RoHS & Non-Green	Call TI	N / A for Pkg Type	-55 to 125	5962R 2122001VXC TRF0206FFM	Samples
TRF0206FFM/EM	ACTIVE	LCCC	FFM	12	50	Non-RoHS & Non-Green	Call TI	N / A for Pkg Type	-55 to 125	TRF0206FFM/EM	Samples

(1) The marketing status values are defined as follows:

ACTIVE: Product device recommended for new designs.

LIFEBUY: TI has announced that the device will be discontinued, and a lifetime-buy period is in effect.

NRND: Not recommended for new designs. Device is in production to support existing customers, but TI does not recommend using this part in a new design.

PREVIEW: Device has been announced but is not in production. Samples may or may not be available.

OBSOLETE: TI has discontinued the production of the device.

(2) **RoHS:** TI defines "RoHS" to mean semiconductor products that are compliant with the current EU RoHS requirements for all 10 RoHS substances, including the requirement that RoHS substance do not exceed 0.1% by weight in homogeneous materials. Where designed to be soldered at high temperatures, "RoHS" products are suitable for use in specified lead-free processes. TI may reference these types of products as "Pb-Free".

RoHS Exempt: TI defines "RoHS Exempt" to mean products that contain lead but are compliant with EU RoHS pursuant to a specific EU RoHS exemption.

Green: TI defines "Green" to mean the content of Chlorine (Cl) and Bromine (Br) based flame retardants meet JS709B low halogen requirements of <=1000ppm threshold. Antimony trioxide based flame retardants must also meet the <=1000ppm threshold requirement.

(3) MSL, Peak Temp. - The Moisture Sensitivity Level rating according to the JEDEC industry standard classifications, and peak solder temperature.

(4) There may be additional marking, which relates to the logo, the lot trace code information, or the environmental category on the device.

(5) Multiple Device Markings will be inside parentheses. Only one Device Marking contained in parentheses and separated by a "~" will appear on a device. If a line is indented then it is a continuation of the previous line and the two combined represent the entire Device Marking for that device.

(6) Lead finish/Ball material - Orderable Devices may have multiple material finish options. Finish options are separated by a vertical ruled line. Lead finish/Ball material values may wrap to two lines if the finish value exceeds the maximum column width.

Important Information and Disclaimer:The information provided on this page represents TI's knowledge and belief as of the date that it is provided. TI bases its knowledge and belief on information provided by third parties, and makes no representation or warranty as to the accuracy of such information. Efforts are underway to better integrate information from third parties. TI has taken and continues to take reasonable steps to provide representative and accurate information but may not have conducted destructive testing or chemical analysis on incoming materials and chemicals. TI and TI suppliers consider certain information to be proprietary, and thus CAS numbers and other limited information may not be available for release.

In no event shall TI's liability arising out of such information exceed the total purchase price of the TI part(s) at issue in this document sold by TI to Customer on an annual basis.

FFM0012A

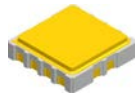

PACKAGE OUTLINE

LCCC - 1.78 mm max height

LEADLESS CERAMIC CHIP CARRIER

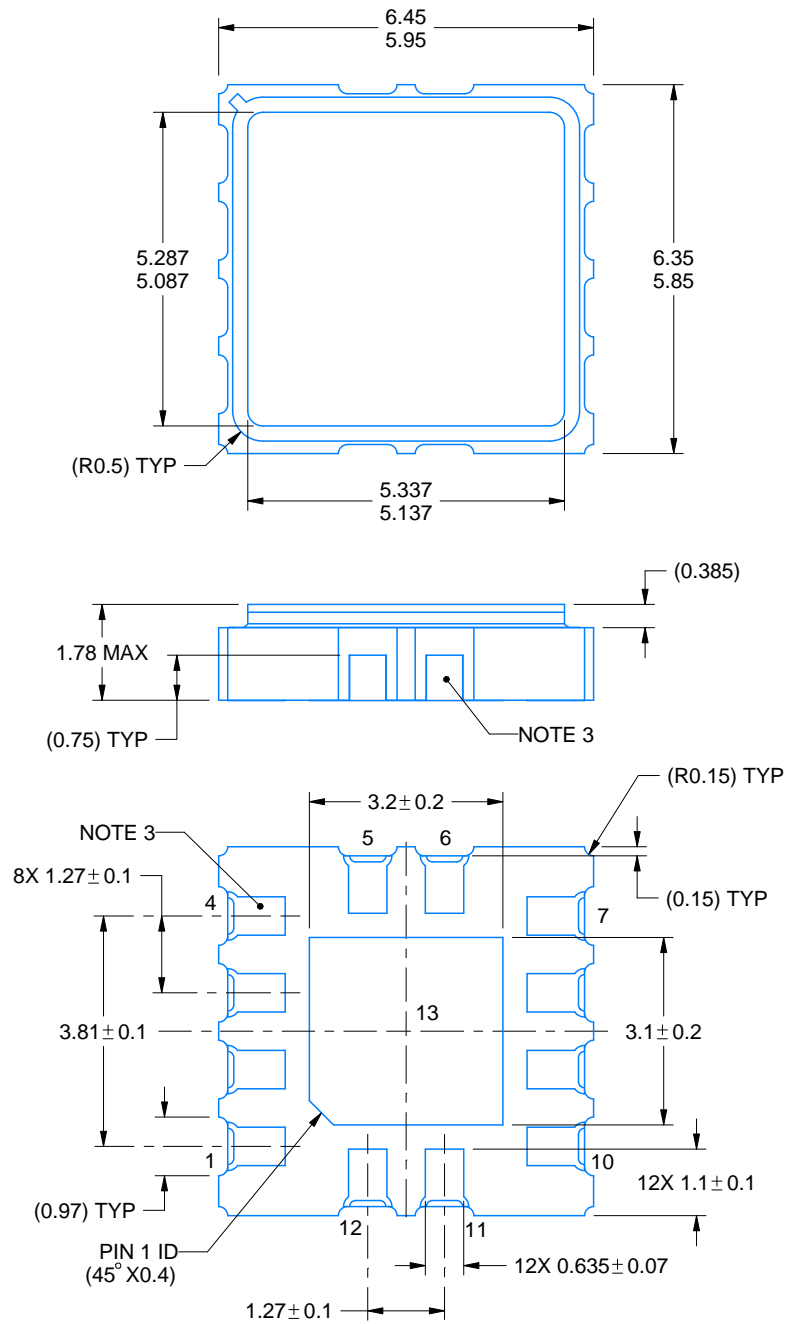

4226328/D 01/2021

NOTES:

1. All linear dimensions are in millimeters. Any dimensions in parenthesis are for reference only. Dimensioning and tolerancing per ASME Y14.5M.
2. This drawing is subject to change without notice.
3. The terminals are gold-plated.

EXAMPLE BOARD LAYOUT

FFM0012A

LCCC - 1.78 mm max height

LEADLESS CERAMIC CHIP CARRIER

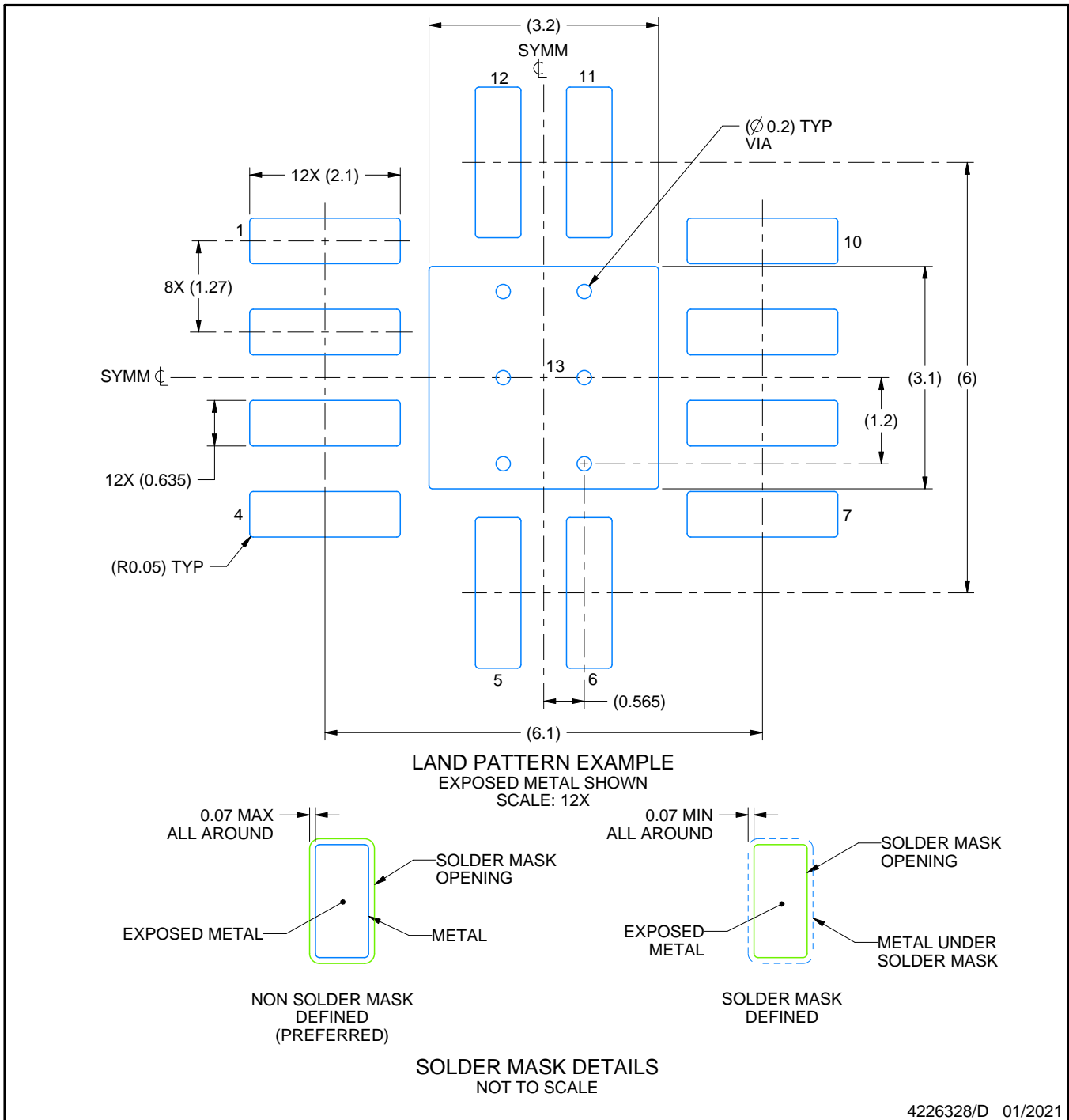

NOTES: (continued)

- This package is designed to be soldered to a thermal pad on the board. For more information, see Texas Instruments literature number SLUA271 (www.ti.com/lit/slua271).
- Vias are optional depending on application, refer to device data sheet. If any vias are implemented, refer to their locations shown on this view. It is recommended that vias under paste be filled, plugged or tented.

EXAMPLE STENCIL DESIGN

FFM0012A

LCCC - 1.78 mm max height

LEADLESS CERAMIC CHIP CARRIER

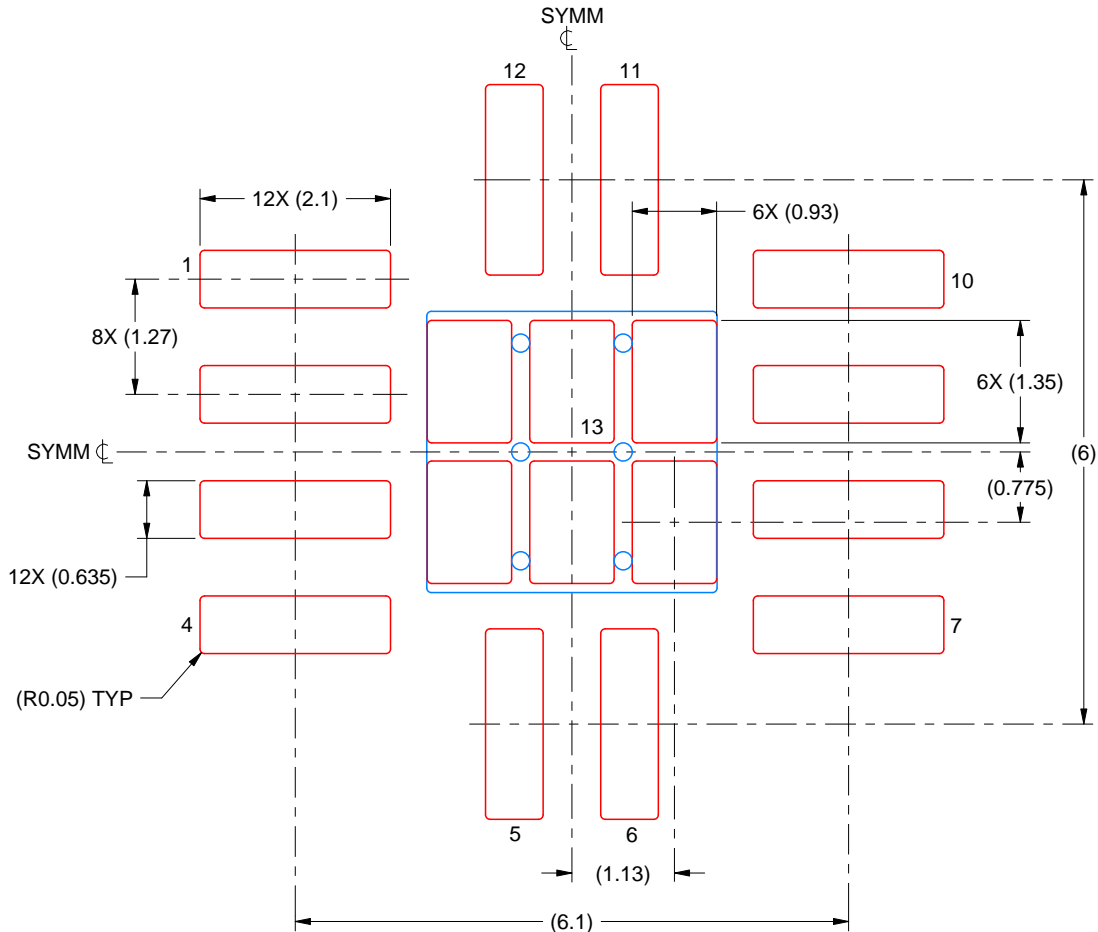

SOLDER PASTE EXAMPLE
BASED ON 0.125 mm THICK STENCIL

EXPOSED PAD 13:
76% PRINTED SOLDER COVERAGE BY AREA UNDER PACKAGE
SCALE: 12X

4226328/D 01/2021

NOTES: (continued)

6. Laser cutting apertures with trapezoidal walls and rounded corners may offer better paste release. IPC-7525 may have alternate design recommendations.

IMPORTANT NOTICE AND DISCLAIMER

TI PROVIDES TECHNICAL AND RELIABILITY DATA (INCLUDING DATA SHEETS), DESIGN RESOURCES (INCLUDING REFERENCE DESIGNS), APPLICATION OR OTHER DESIGN ADVICE, WEB TOOLS, SAFETY INFORMATION, AND OTHER RESOURCES "AS IS" AND WITH ALL FAULTS, AND DISCLAIMS ALL WARRANTIES, EXPRESS AND IMPLIED, INCLUDING WITHOUT LIMITATION ANY IMPLIED WARRANTIES OF MERCHANTABILITY, FITNESS FOR A PARTICULAR PURPOSE OR NON-INFRINGEMENT OF THIRD PARTY INTELLECTUAL PROPERTY RIGHTS.

These resources are intended for skilled developers designing with TI products. You are solely responsible for (1) selecting the appropriate TI products for your application, (2) designing, validating and testing your application, and (3) ensuring your application meets applicable standards, and any other safety, security, regulatory or other requirements.

These resources are subject to change without notice. TI grants you permission to use these resources only for development of an application that uses the TI products described in the resource. Other reproduction and display of these resources is prohibited. No license is granted to any other TI intellectual property right or to any third party intellectual property right. TI disclaims responsibility for, and you will fully indemnify TI and its representatives against, any claims, damages, costs, losses, and liabilities arising out of your use of these resources.

TI's products are provided subject to [TI's Terms of Sale](#) or other applicable terms available either on [ti.com](https://www.ti.com) or provided in conjunction with such TI products. TI's provision of these resources does not expand or otherwise alter TI's applicable warranties or warranty disclaimers for TI products.

TI objects to and rejects any additional or different terms you may have proposed.

Mailing Address: Texas Instruments, Post Office Box 655303, Dallas, Texas 75265
Copyright © 2024, Texas Instruments Incorporated