

DPI Evaluation TPS65310-Q1

Michael Wendt

Mixed Signal Automotive-Catalog

ABSTRACT

The TPS65310A-Q1 is a power management unit, meeting the requirements of DSP controlled automotive systems (e.g. Advanced Driver Assistance Systems). With its integration of commonly used features it helps to significantly reduce board space and system costs.

The device includes one high voltage buck controller for pre-regulation combined with two buck and one boost converter for post regulation. A further integrated LDO rounds up the power supply concept and offers a flexible system design with in total five independent voltage rails. The device offers a low power state LPM0 with all rails off to reduce current consumption in case the system is constantly connected to the battery line. All outputs are protected against overload and over temperature.

An external PMOS makes the device capable of sustaining voltage transients up to 80 V (protection feature). This external PMOS can also be used in safety critical applications to protect the system in case one of the rails shows a malfunction (under-/overvoltage, over current).

Internal Soft start ensures controlled start up for all supplies. Each power supply output has adjustable output voltage based on the external resistor network settings.

The DPI (Direct Power Injection) evaluation will show the robustness of the TPS65310 device during HF Power injection at Global Pins. This test cannot replace other customer tests like BCI (Bulk Current Injection), but it gives a first indication how the device behave under HF stress.

Contents

1	DPI test TPS65310	3
2	DPI set up.....	4
3	The Test Flow	5
4	Equipment used for the DPI test	6
5	Application data	6
6	Nodes Stressed with DPI in Application Circuit TPS65310	7
7	Observed Signal During DPI Stress	7
8	Test Results.....	8
	8.1 J26, VSSENSE, CW, Load	8
	8.2 J26, VSSENSE, AM, Load.....	9
	8.3 J25, VIN, CW, Load.....	10
	8.4 J25, VIN, AM, Load	11
	8.5 J21, WAKE, CW, Load	12
	8.6 J21, WAKE, AM, Load.....	13
	8.7 J10, HSSENSE, CW, Load.....	14
	8.8 J10, HSSENSE, AM, Load.....	15
	8.9 J11, HSCTRL, CW, Load.....	16
	8.10 J11, HSCTRL, AM, Load	17
	8.11 J20, LDO, CW, Load.....	18
	8.12 J20, LDO, AM, Load	19
	8.13 J19, VBOOST, CW, Load	20
	8.14 J19, VBOOST, AM, Load.....	21
	8.15 J19, VBOOST, AM, Load.....	22
	8.16 J22, VSUP2, CW, Load	23
	8.17 J22, VSUP2, AM, Load.....	24
	8.18 J24, S1_Buck, CW, Load.....	25
	8.19 J24, S1_Buck, AM, Load	26
	8.20 J3, VSENSE1, CW, load.....	26
	8.21 J7, VSENSE2, CW, load.....	26
	8.22 J5, VSENSE3, CW, load.....	26
	8.23 J25, VIN, CW, No Load	27
	8.24 J25, VIN, CW, Load.....	28
9	DPI Test Summary.....	29

Figures

Figure 1.	DPI Set Up	4
Figure 2.	Test Flow	5

1 **DPI test TPS65310**

To ensure the EMC performance of the TPS65310, a BCI test in the real application is needed.

- The BCI (Bulk Current injection) test is difficult in an early phase of the system development since ECU is not available yet.
- Without BCI test results failures might be detected too late in the development flow.
- The DPI test is one way to detect EMC weakness of the device even if it does not ensure the pass of the BCI test.
- For the DPI test the TPS65310 is used on standard EVM at room temperature (about 25°C). The DUT (Device under Test) is soldered on the board.
- The TPS65310 was stressed with injected HF power at certain nodes and the reaction of the device will be observed. Step by step the forward power will be increased up to 30 dBm (1 W) maximum peak. This test was performed at certain frequencies.
- Certain signals are observed in digital way and analog output voltages with a multimeter or oscilloscope.
- For each first failure the HF power and the type of failure was documented.
- The same procedure will be performed for the next frequency.
- The 16 suggested frequencies are: 1 MHz, 2 MHz, 3 MHz, 5 MHz, 8 MHz, 10 MHz, 20 MHz, 30 MHz, 50 MHz, 80 MHz, 100 MHz, 200 MHz, 300 MHz, 500 MHz, 800 MHz, 1 GHz
- DPI test signal is CW and AM 1 KHZ modulation and 80% modulation.

2 DPI set up

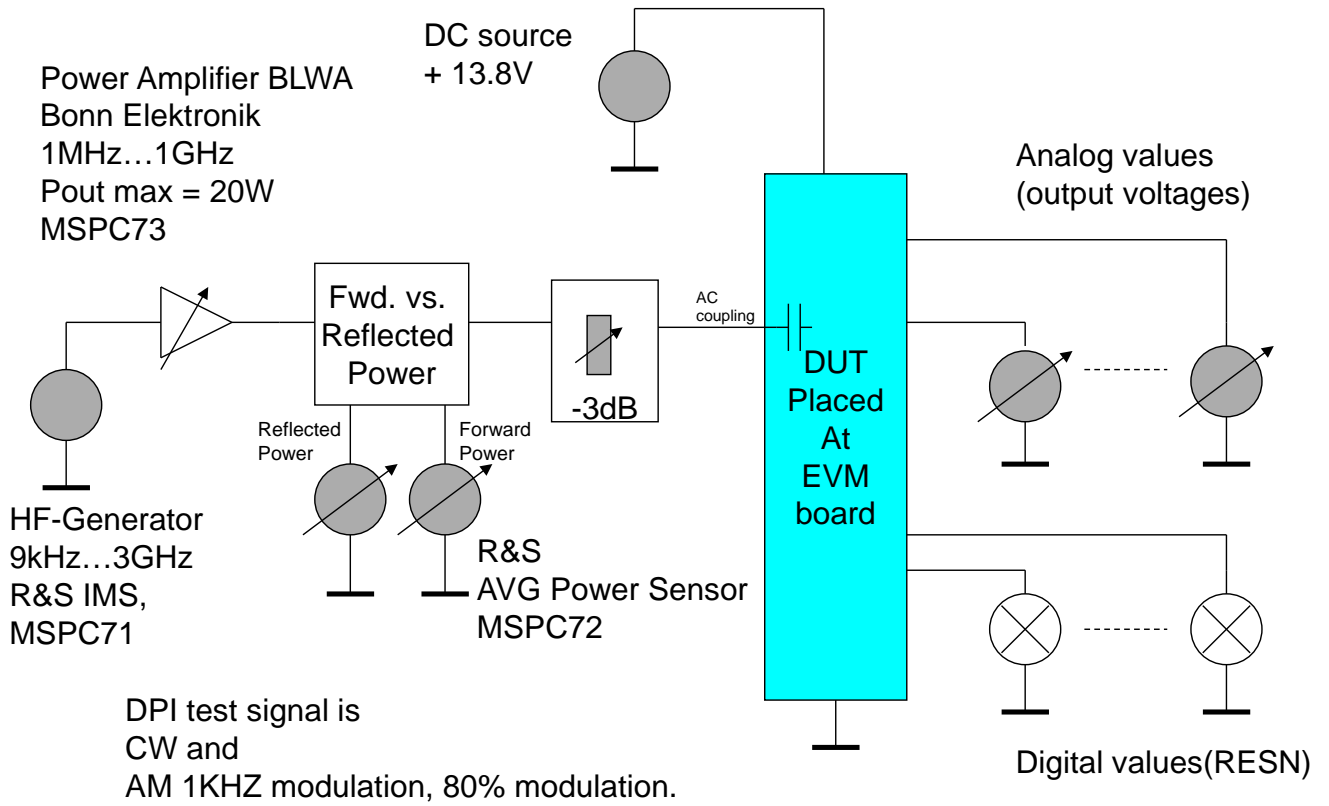

Figure 1. DPI Set Up

3 The Test Flow

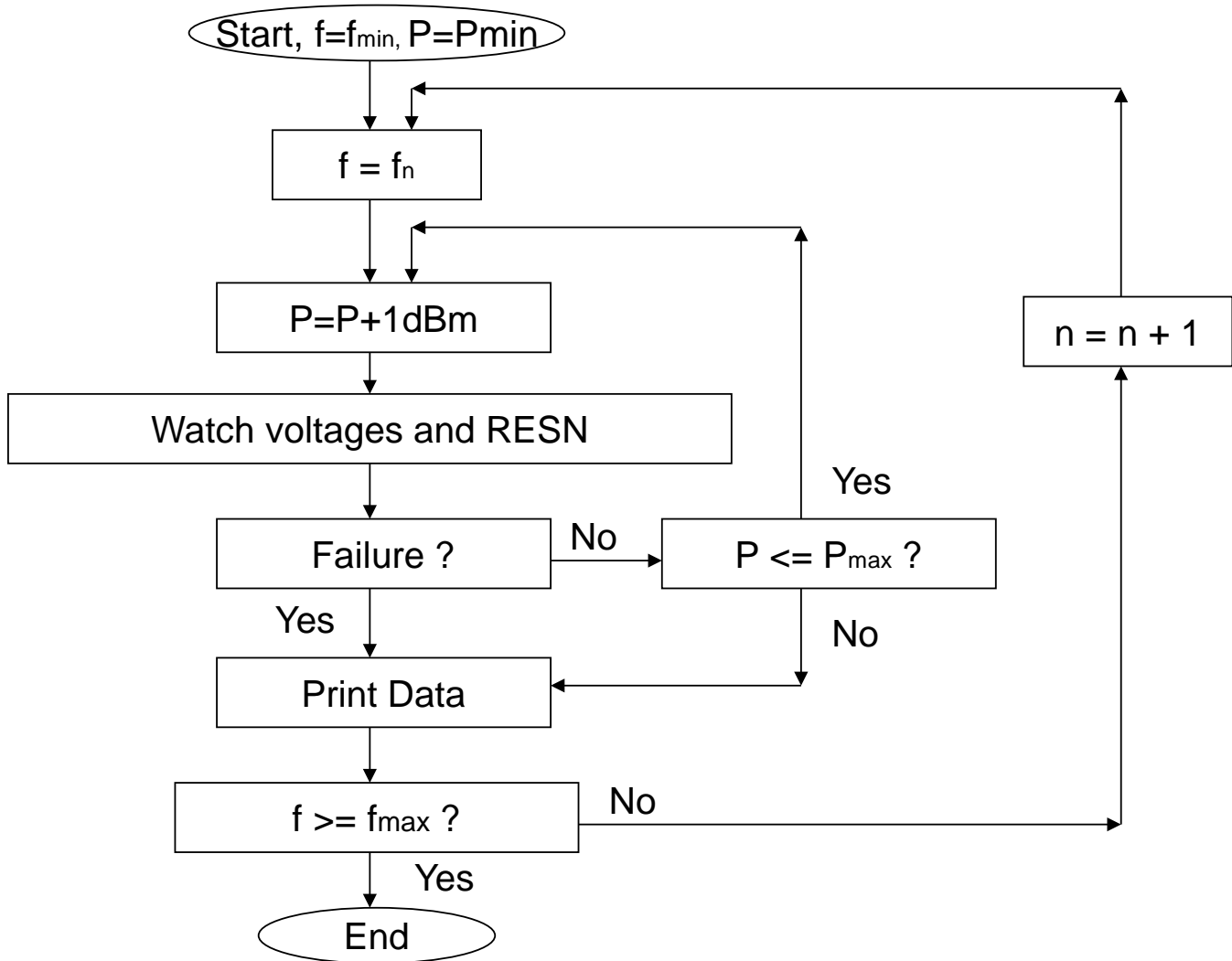

Figure 2. Test Flow

4 Equipment used for the DPI test

- TPS65310_EMC Rev A, DPI population
- Power Supply Statron, MSPC16
- HF-Generator, Rohde & Schwarz, IMS, 9kHz-3GHz, MSPC71
- HF Amplifier, Bonn Elektronik, BLWA 0110-20, 1 MHz–1 GHz, 20 W, MSPC72
- Power Sensor, Rohde & Schwarz, NRP-Z91, MSPC72
- Multimeter Fluke 175, MSPC57, MSPC83
- Multimeter Keithley 2000, MSPC50
- MultiMate Keithley 2100, MSPC94, MSPC95
- Oscilloscope Le Croy 6100, MSPC9

5 Application data

Used board: TPS65310_EMC Rev A, DPI population. The device was stressed with standard load and with no load condition.

- Used board: TPS65310_EMC Rev A, DPI population
- Vbat = 13.3 V
- Buck1
 - 3.8 V
 - No load
- Buck2
 - 3.3 V, 0.45 A
 - 7.4 Ohm
- Buck3
 - 1.2 V, 0.4 A
 - 2.7 Ohm
- Boost
 - 5.0 V, 0.4 A
 - 12 Ohm
- LDO
 - 2.5 V, 0.06 A
- 40 Ohm

6 Nodes Stressed with DPI in Application Circuit TPS65310

- Global Pins
 - VSSENSE
 - VIN
 - VINPROT(not tested, decision during EMC board development)
 - WAKE
 - HSSENSE
- Local Pins
 - HSCTRL
 - LDO
 - VBOOST
 - VSUP2,3,4 = VBUCK1 connected together, only tested VSUP2 = J22
 - S1_BUCK1(S1,S2 together)
 - VMONx,VSENSEx, not testable

7 Observed Signal During DPI Stress

- BUCK1
- BUCK2
- BUCK3
- BOOST
- LDO
- SPI register failure

8 Test Results

8.1 J26, VSSENSE, CW, Load

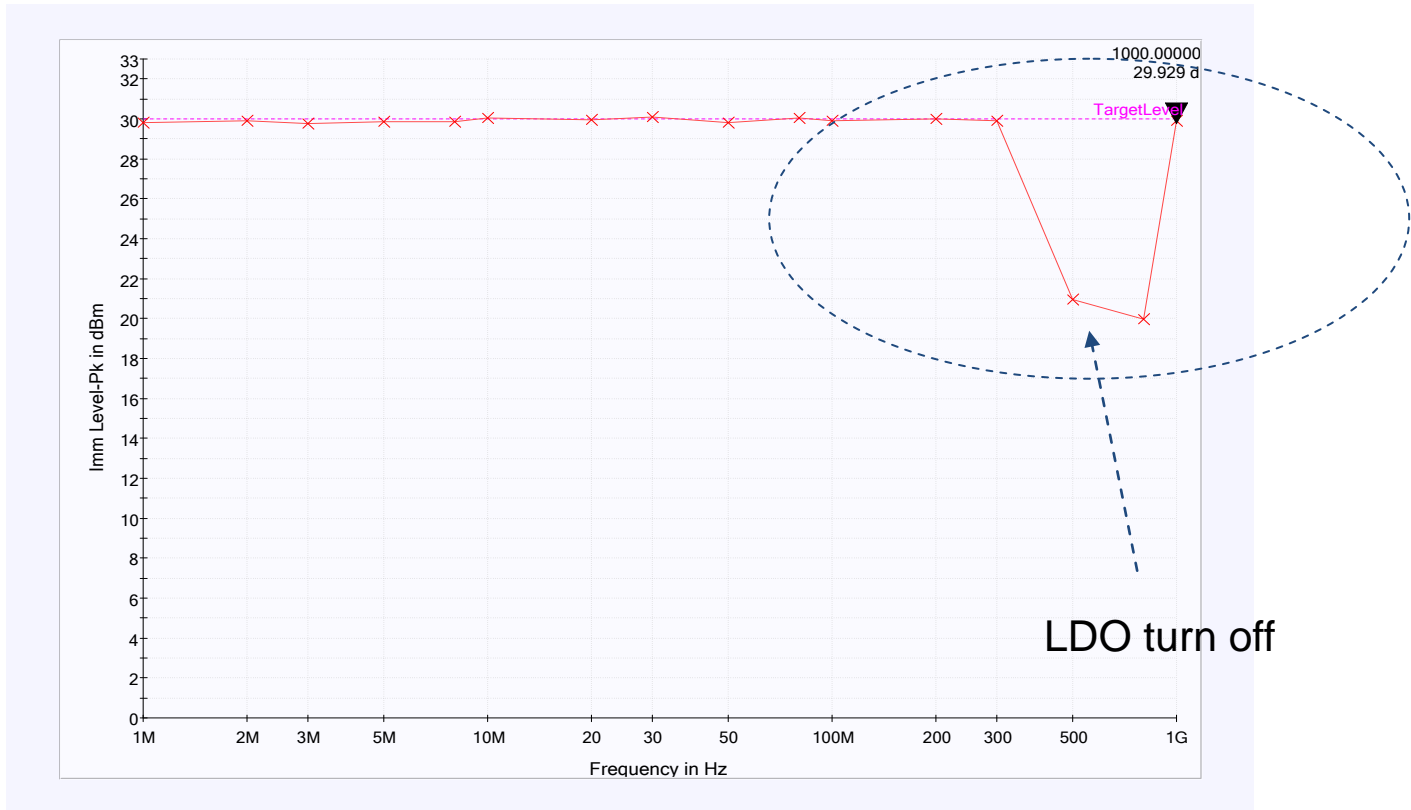

8.2 J26, VSSENSE, AM, Load

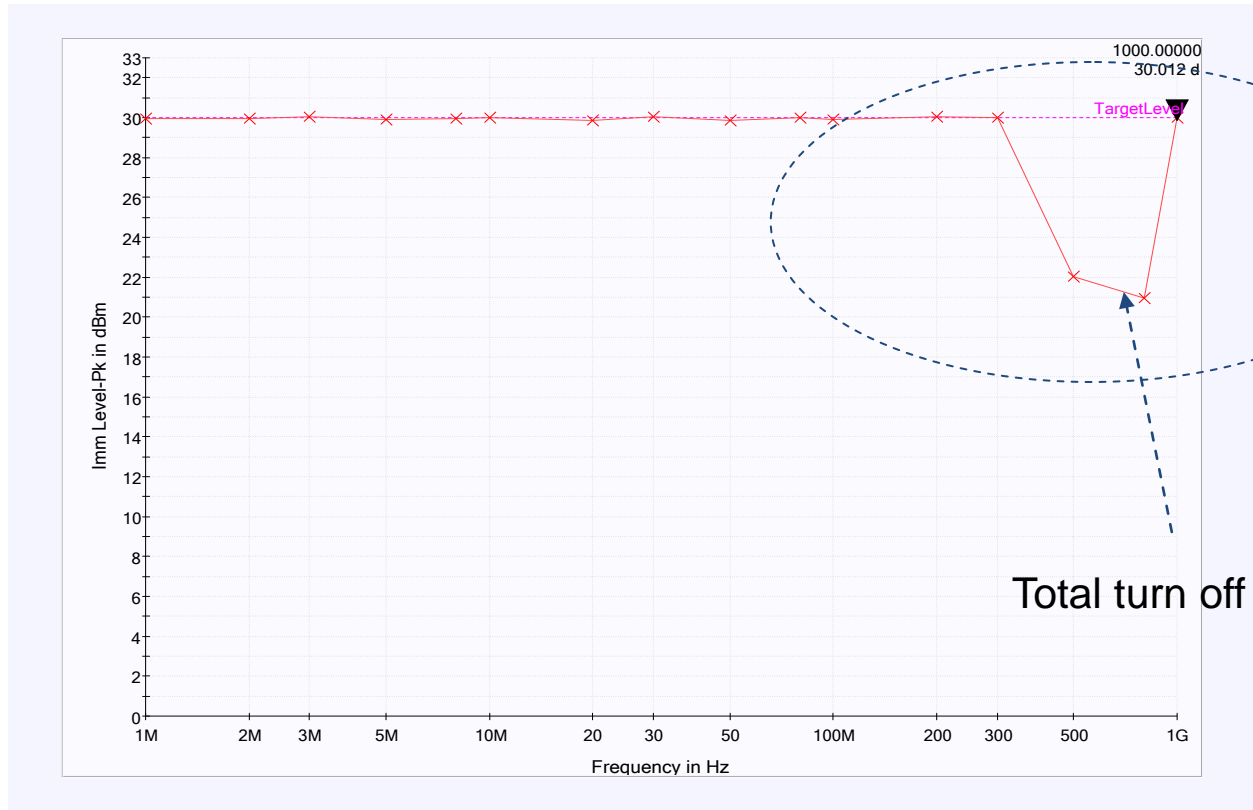

8.3 J25, VIN, CW, Load

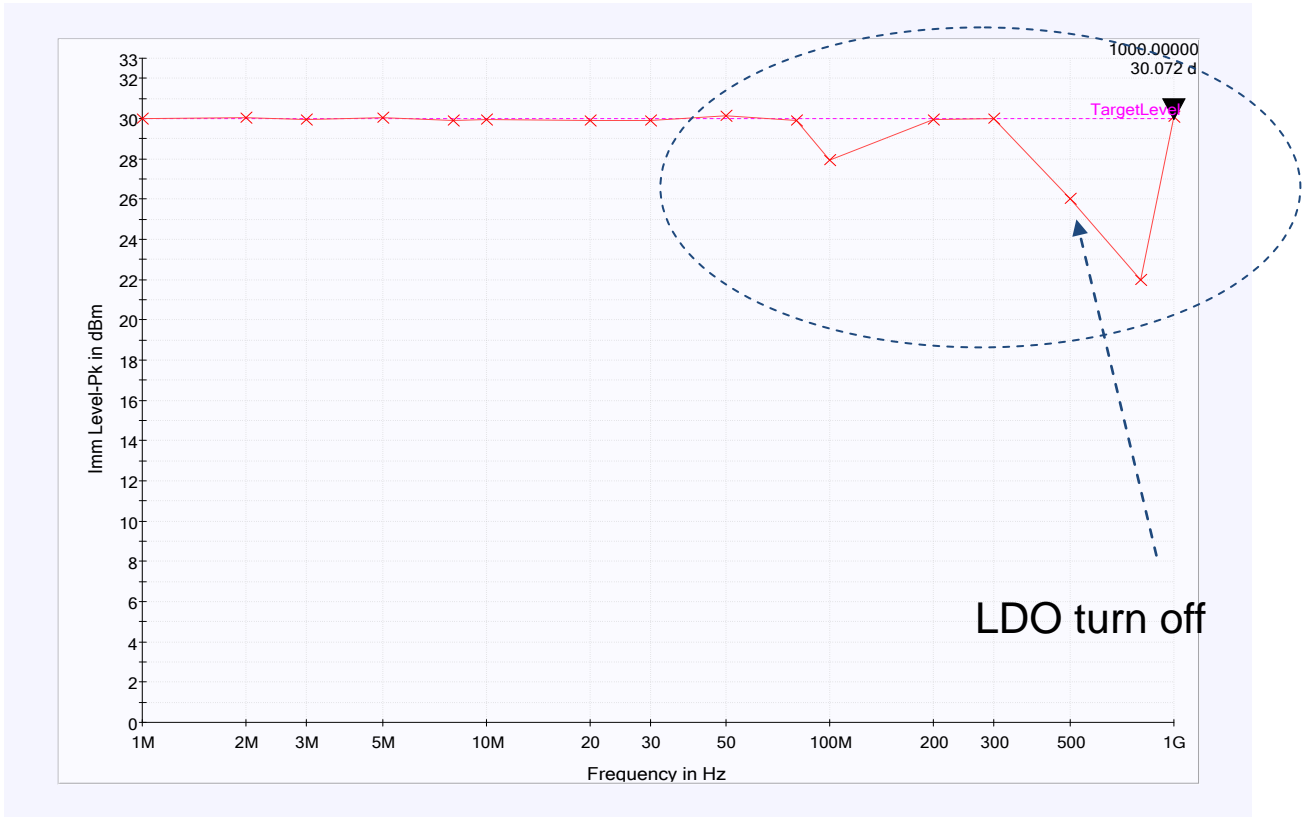

8.4 J25, VIN, AM, Load

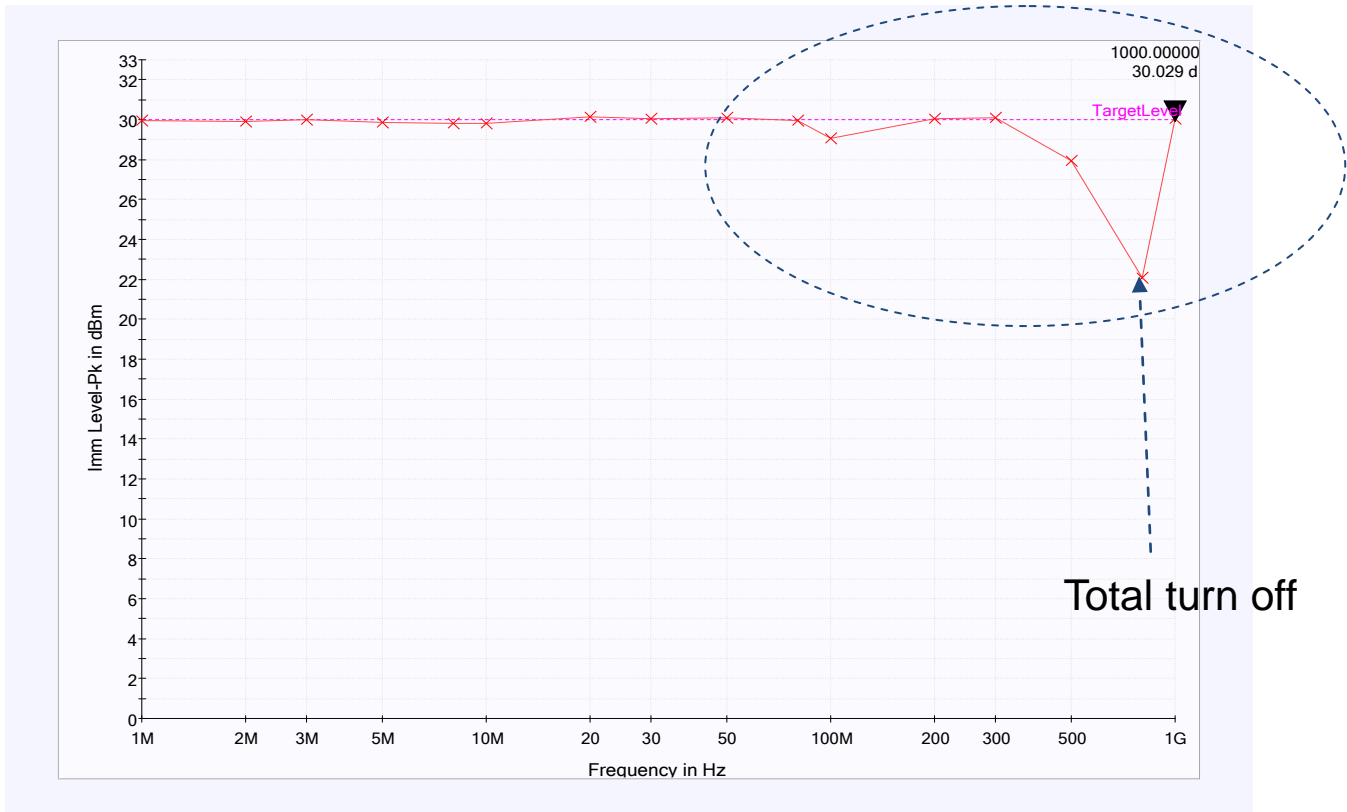

8.5 J21, WAKE, CW, Load

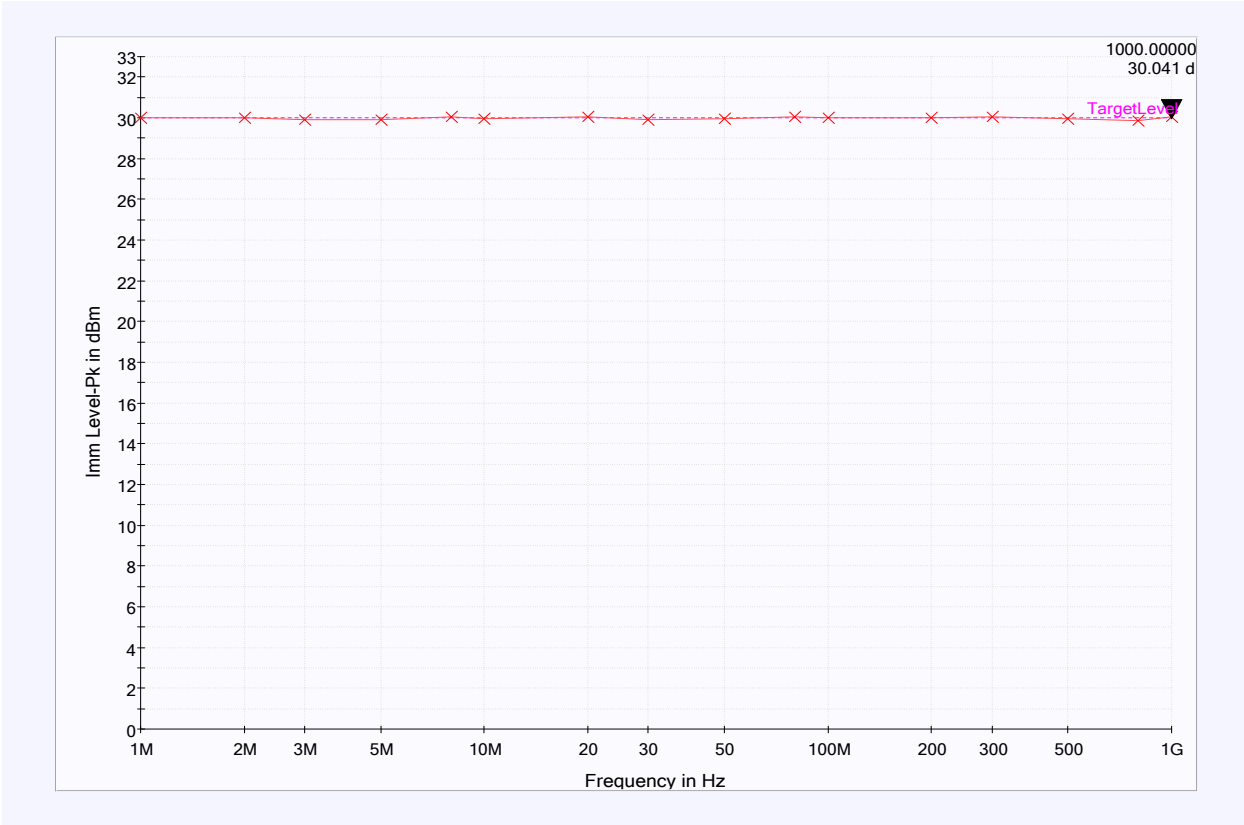

8.6 J21, WAKE, AM, Load

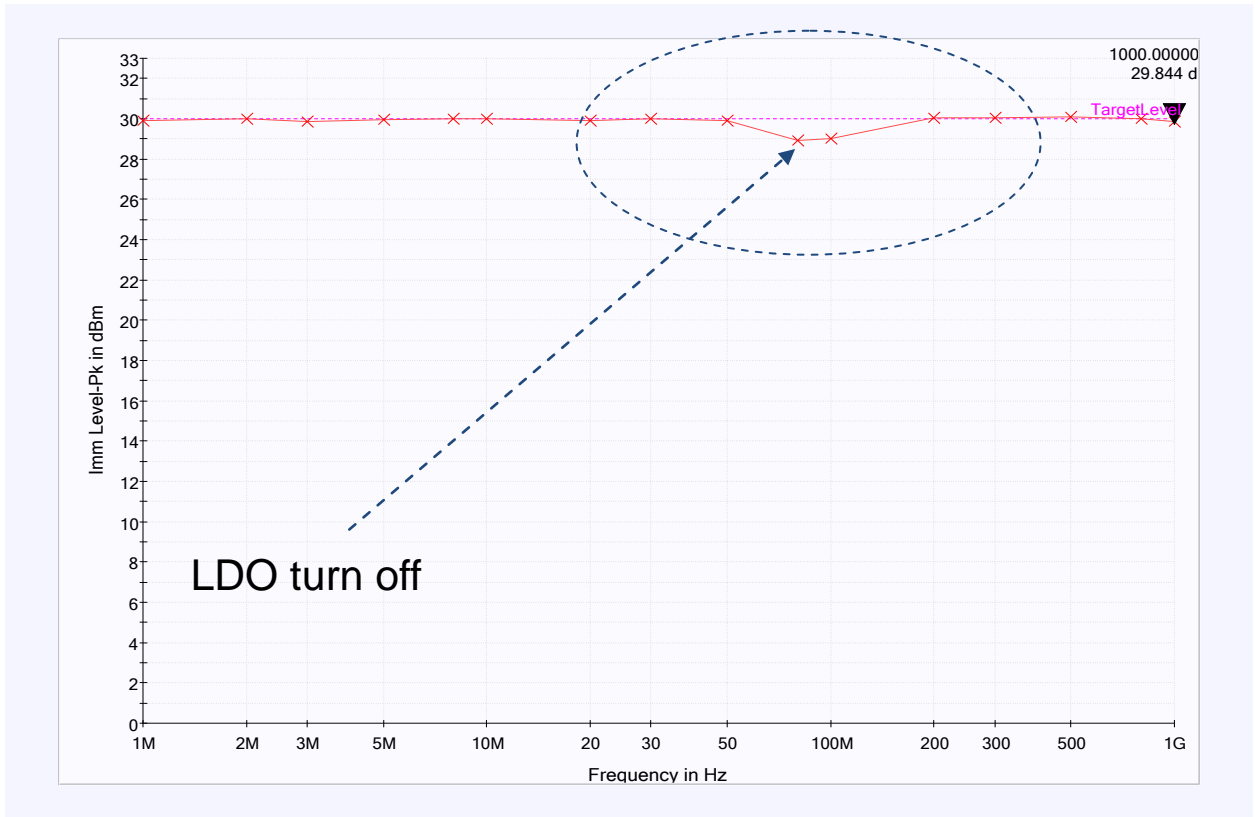

8.7 J10, HSENSE, CW, Load

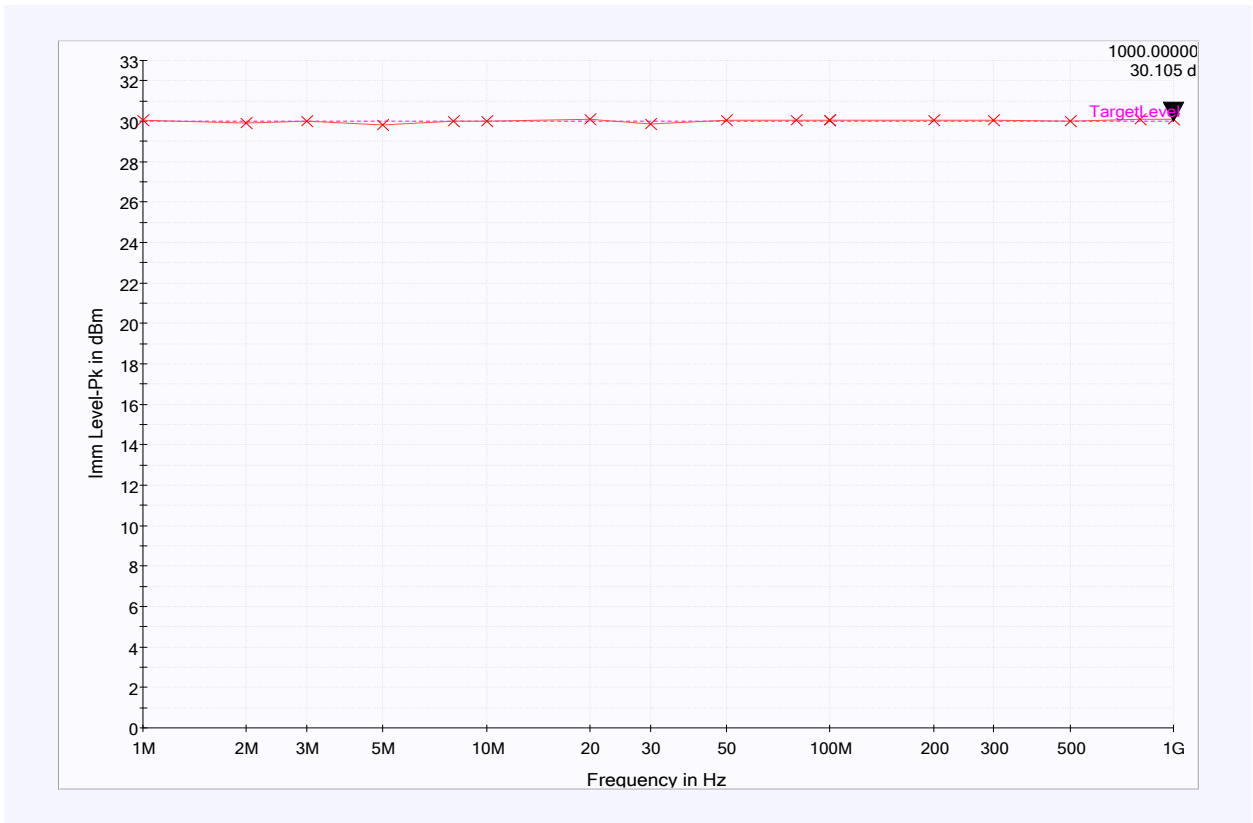

8.8 J10, HSENSE, AM, Load

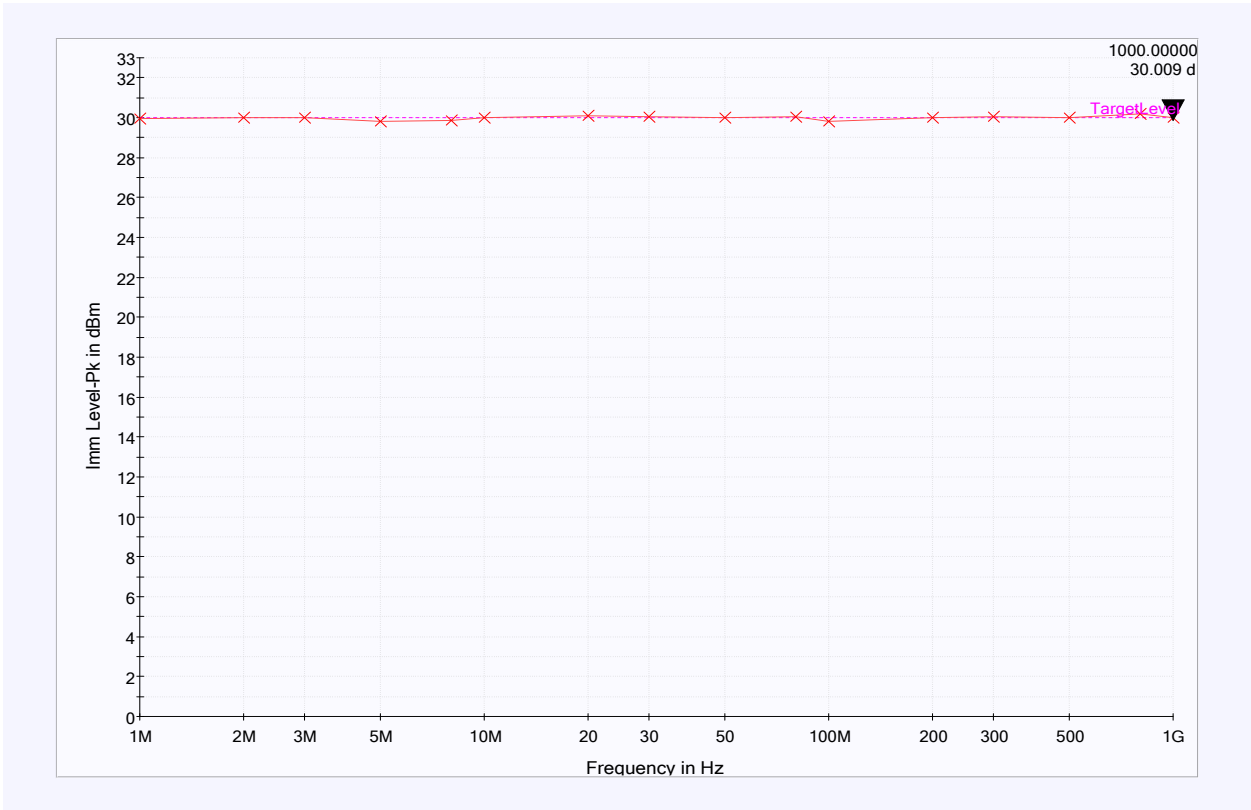

8.9 J11, HSCTRL, CW, Load

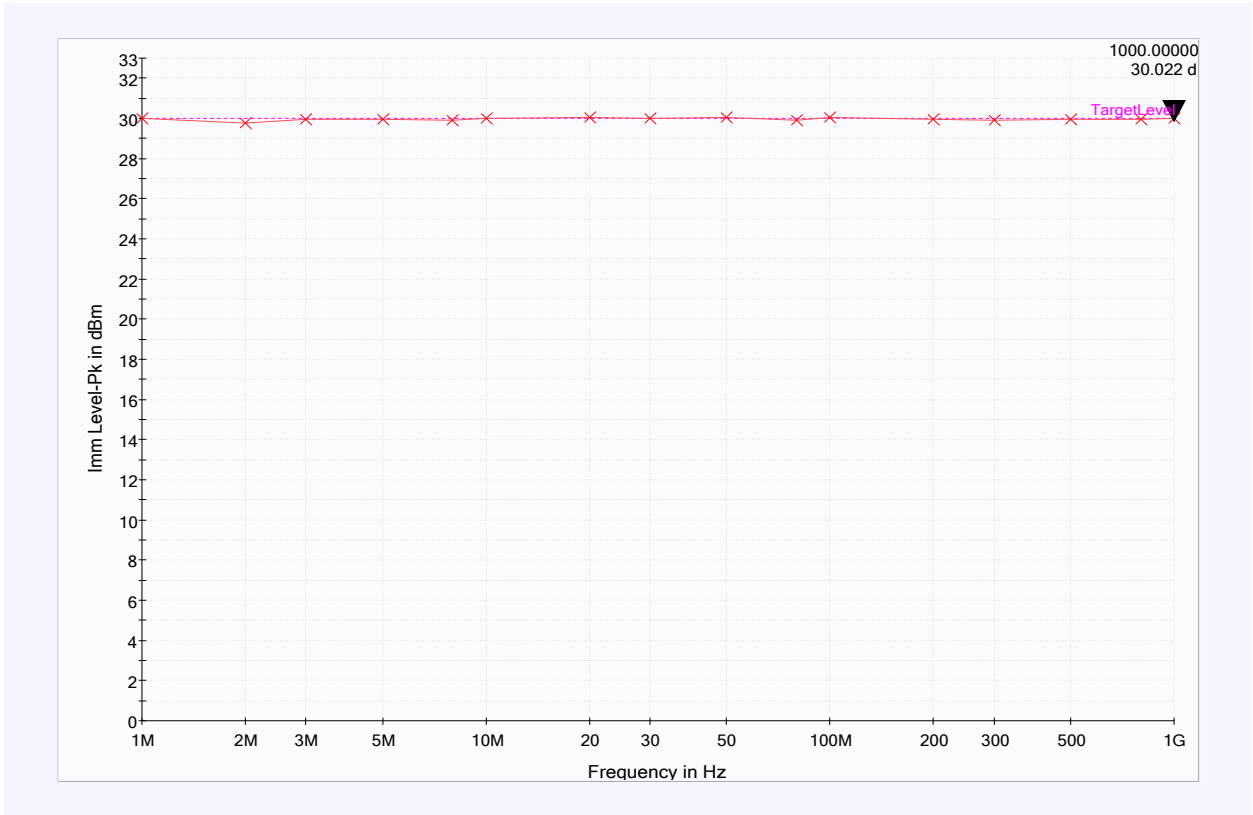

8.10 J11, HSCTRL, AM, Load

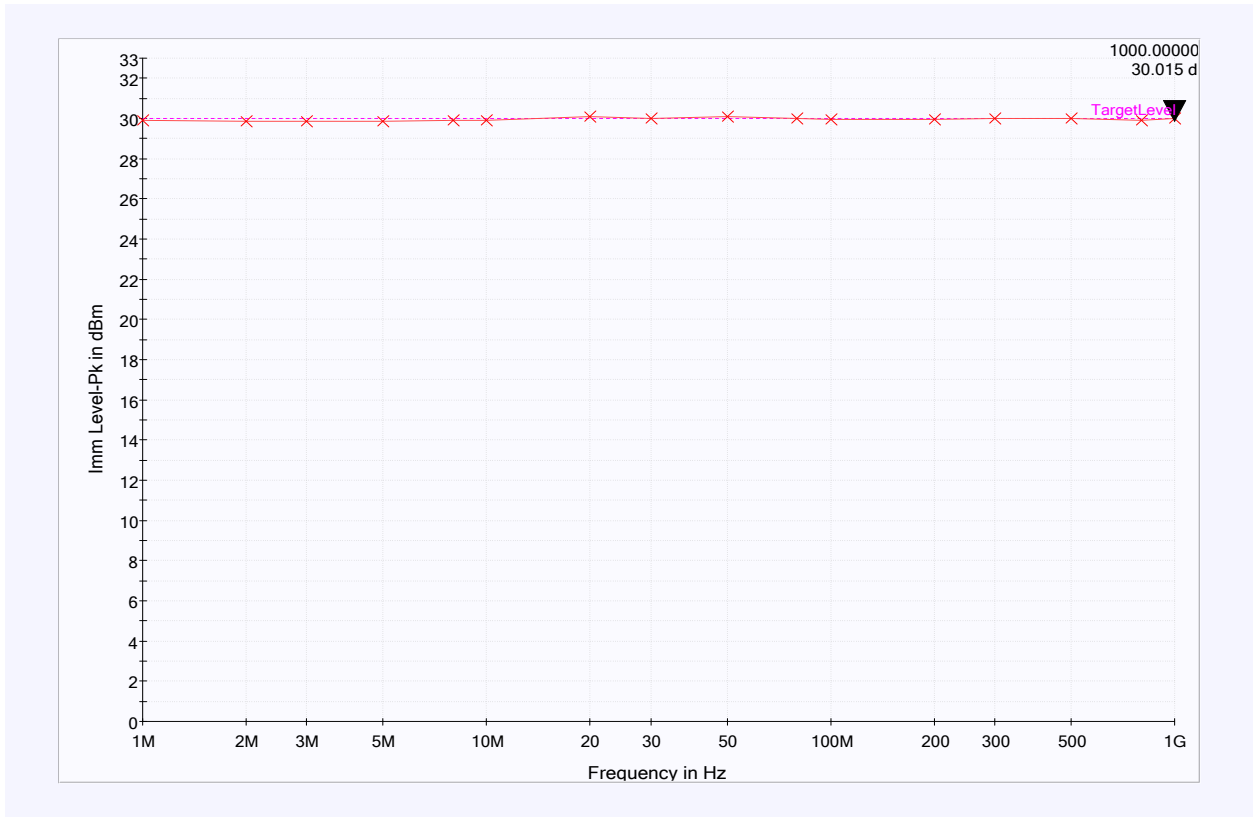

8.11 J20, LDO, CW, Load

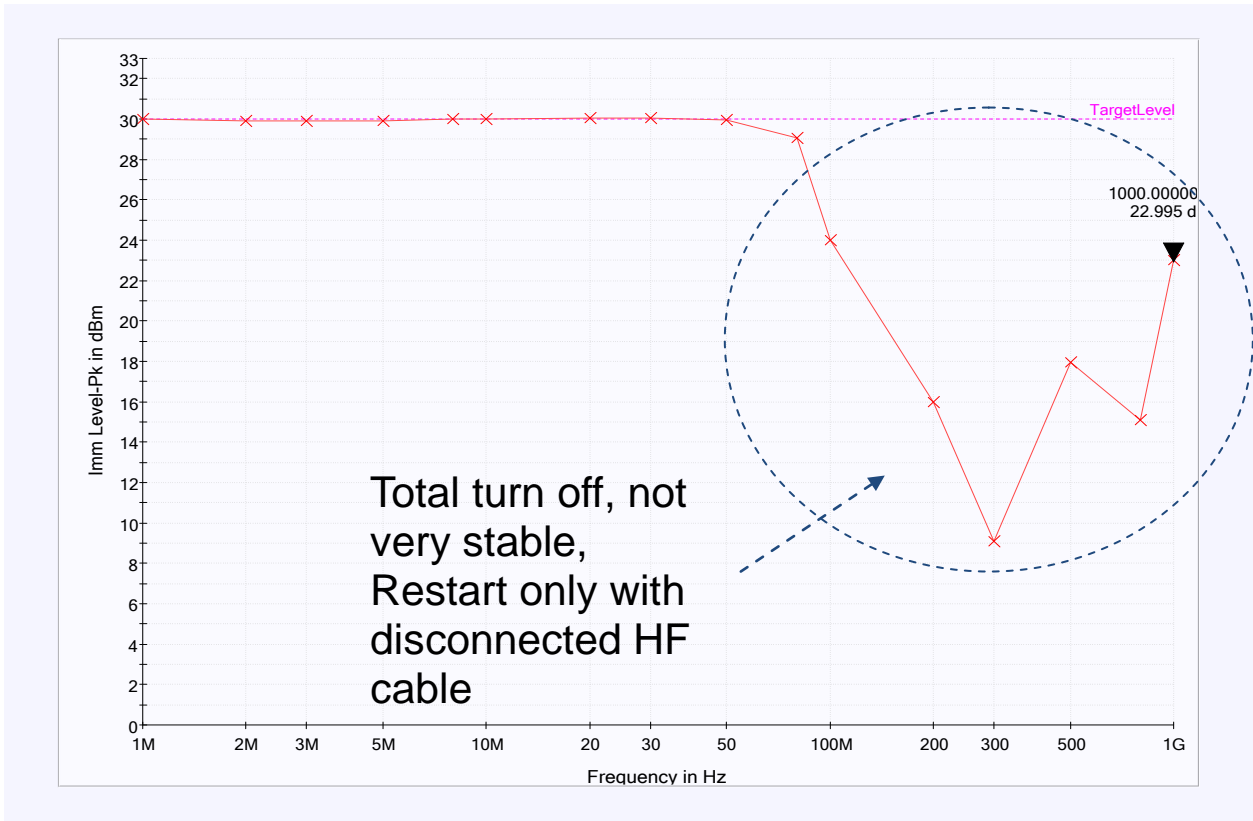

8.12 J20, LDO, AM, Load

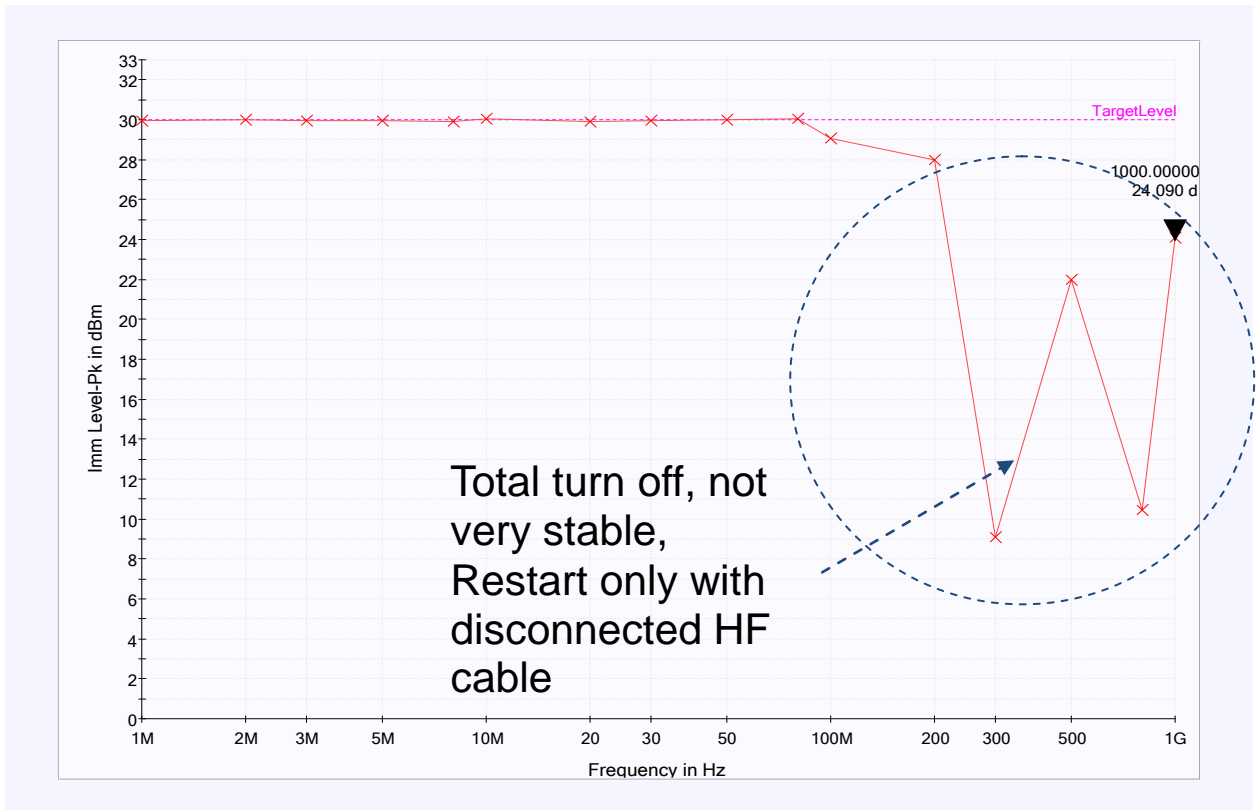

8.13 J19, VBOOST, CW, Load

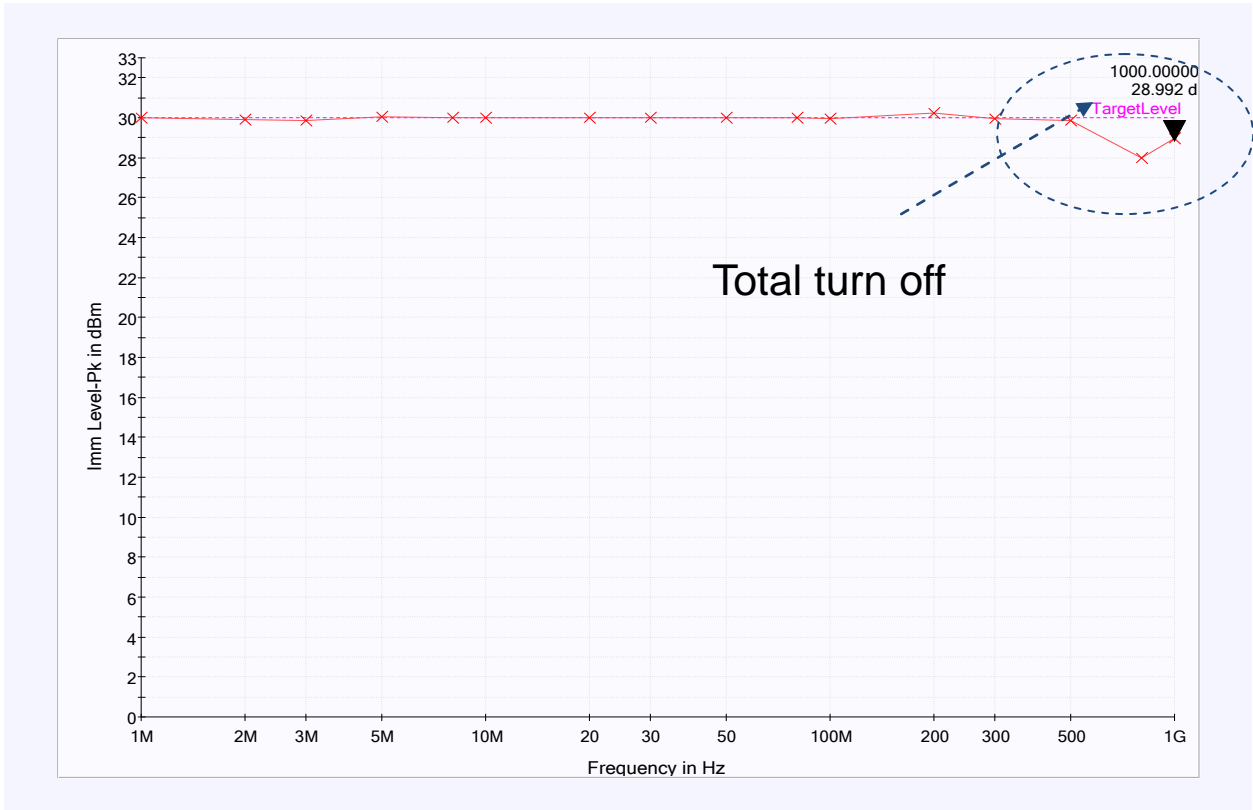

8.14 J19, VBOOST, AM, Load

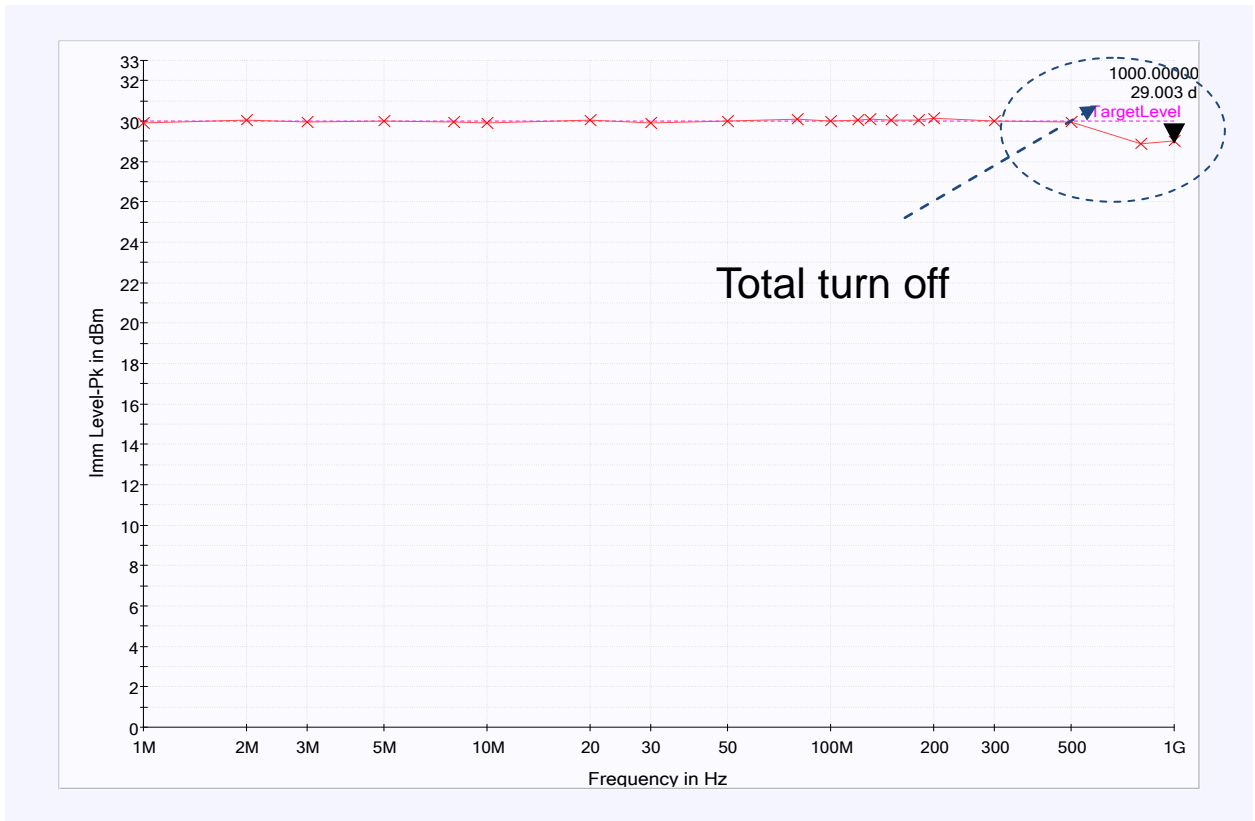

8.15 J19, VBOOST, AM, Load

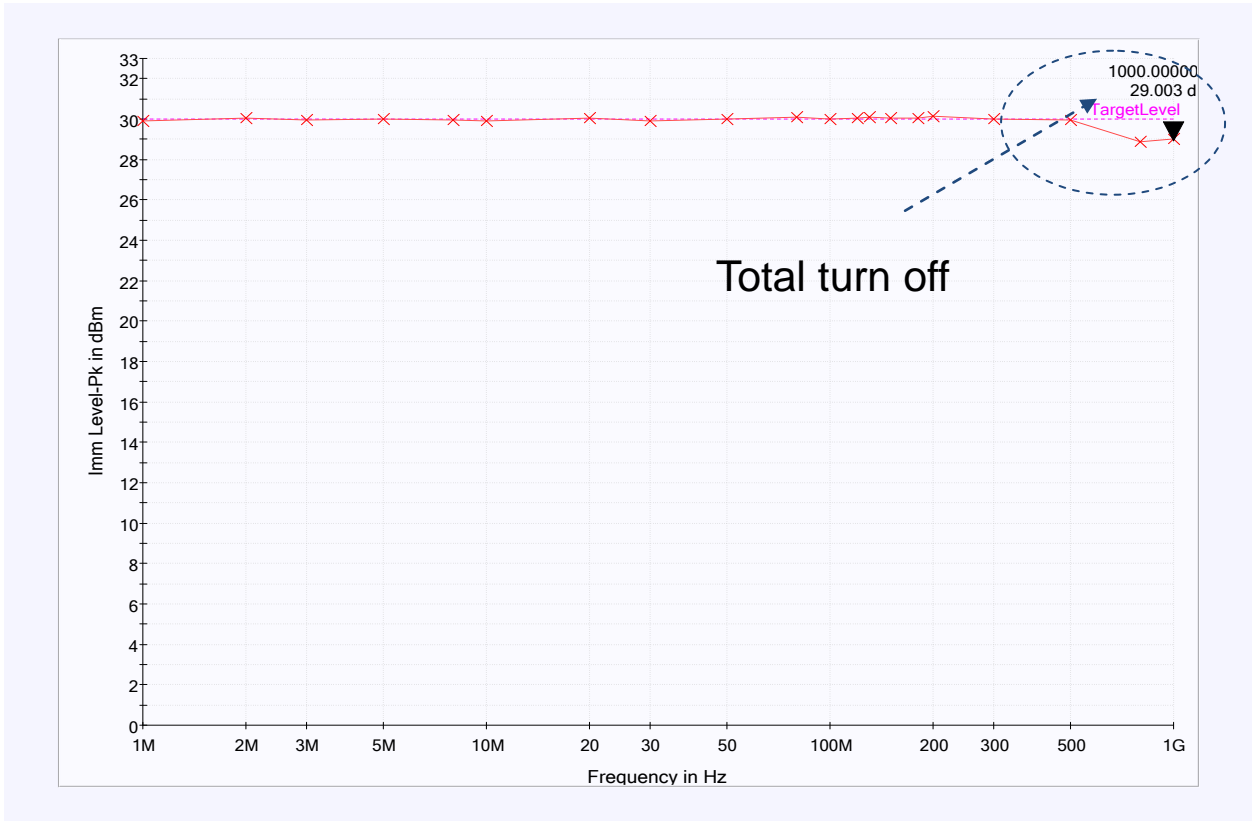

8.16 J22, VSUP2, CW, Load

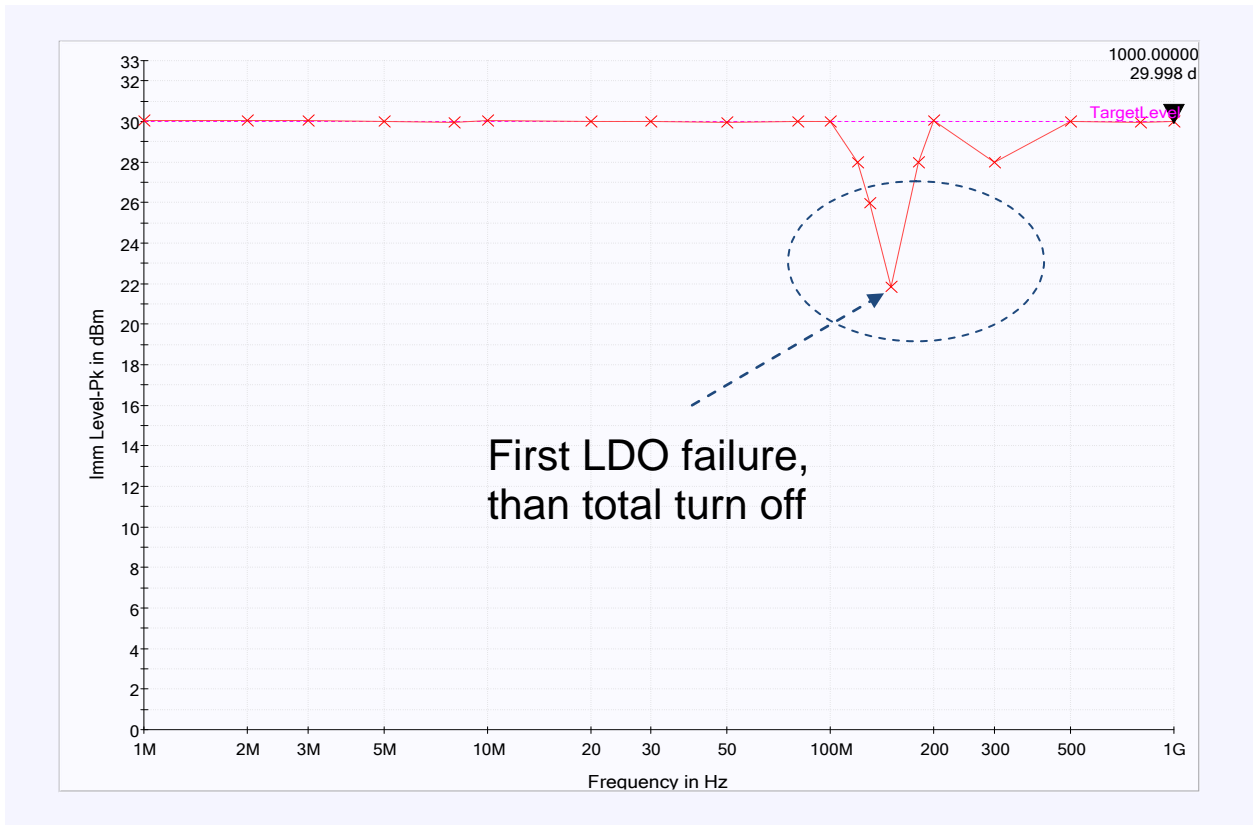

8.17 J22, VSUP2, AM, Load

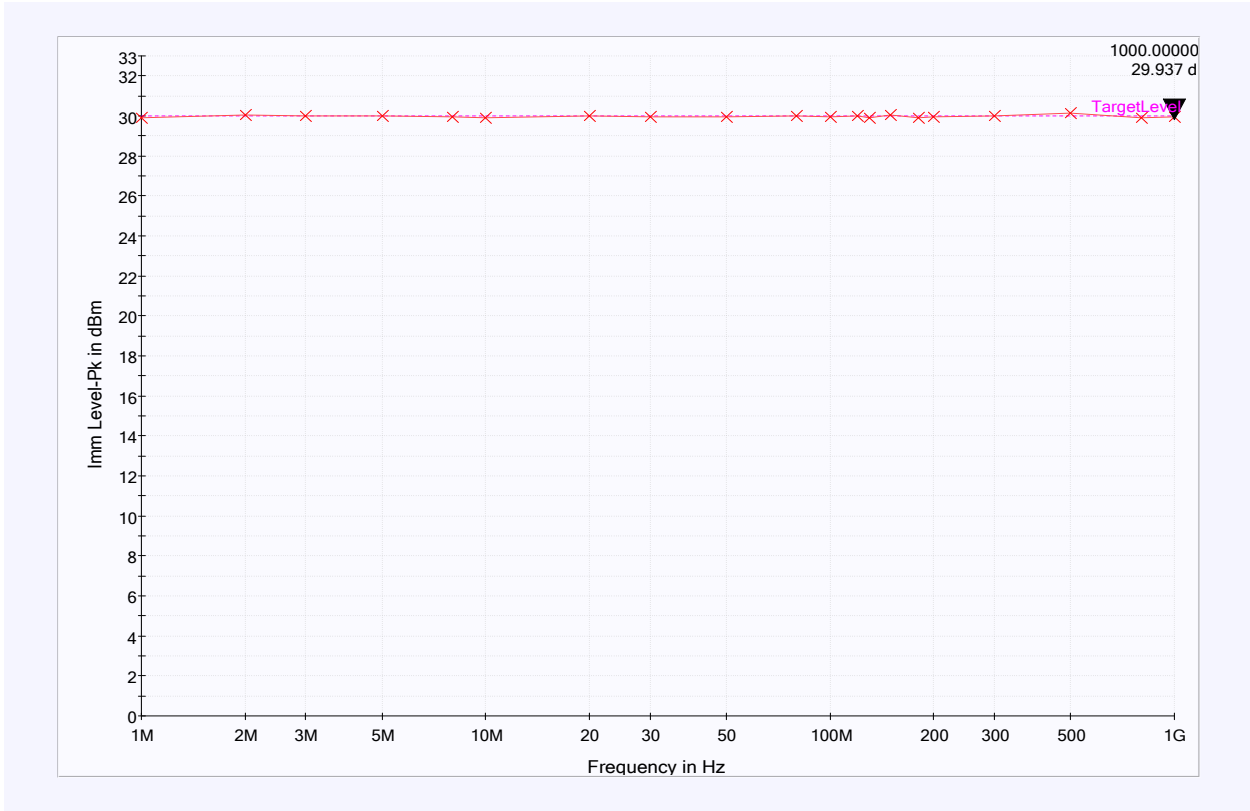

8.18 J24, S1_Buck, CW, Load

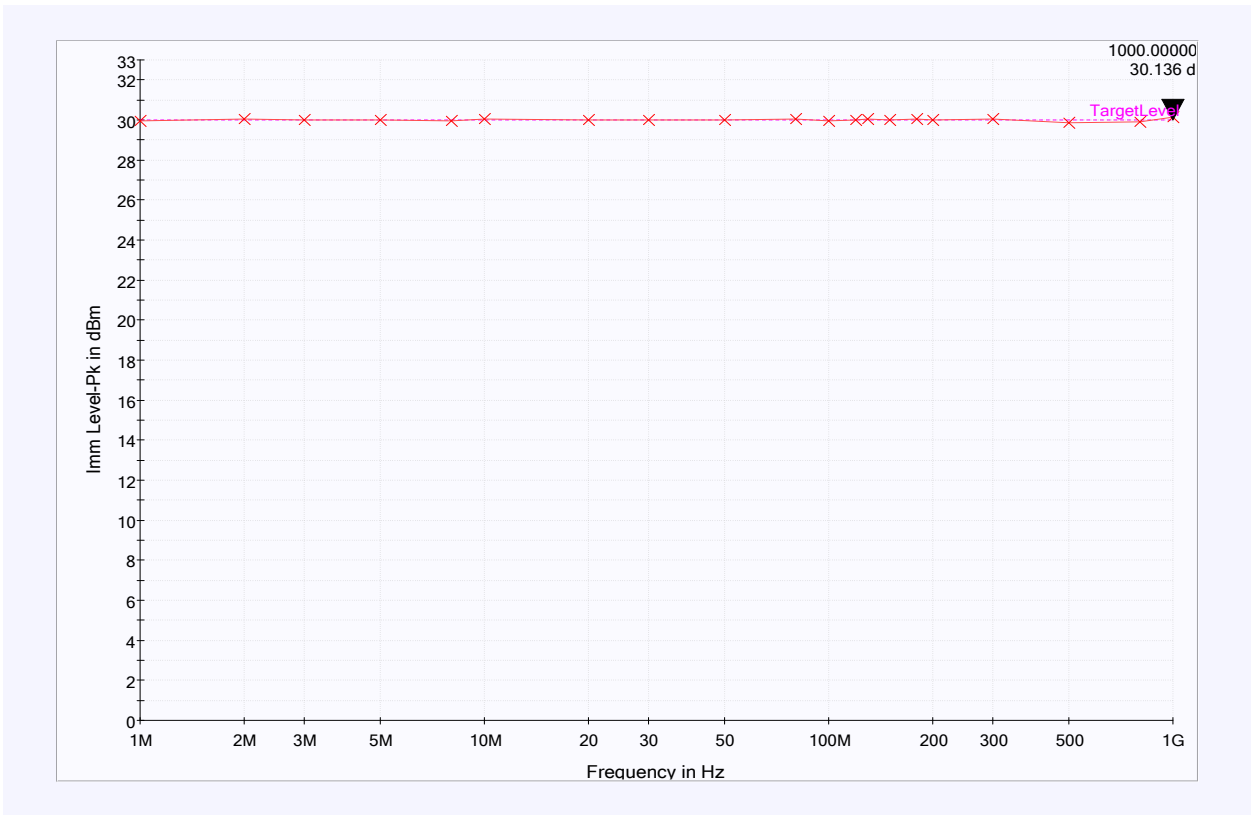

8.19 J24, S1_Buck, AM, Load

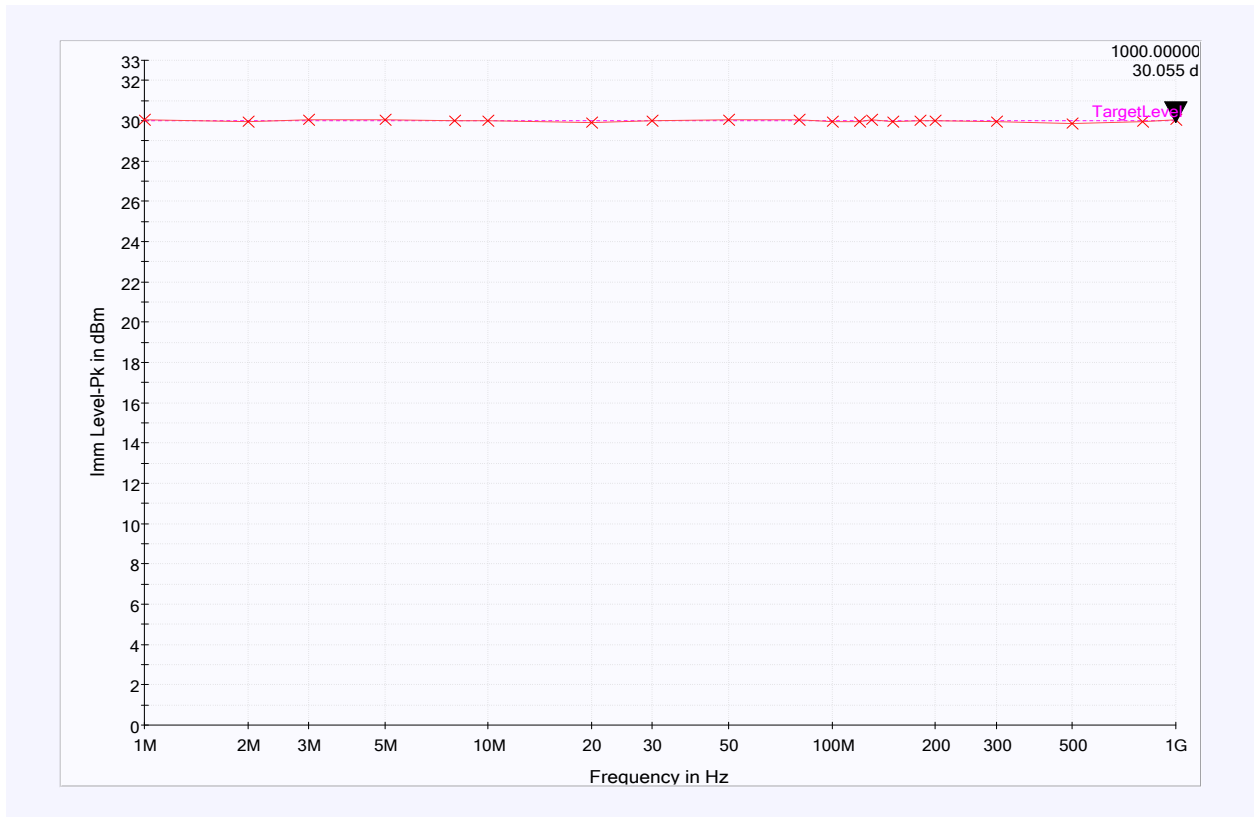

8.20 J3, VSENSE1, CW, load

By connecting the HF Amplifier to the EMC board J3, total failure observed even without HF injection.

8.21 J7, VSENSE2, CW, load

By connecting the HF Amplifier to the EMC board J3, total failure observed even without HF injection.

8.22 J5, VSENSE3, CW, load

By connecting the HF Amplifier the EMC board J5, device was operating without HF.

By turning on the HF amplifier, the device was broken and not starting anymore.

8.23 J25, VIN, CW, No Load

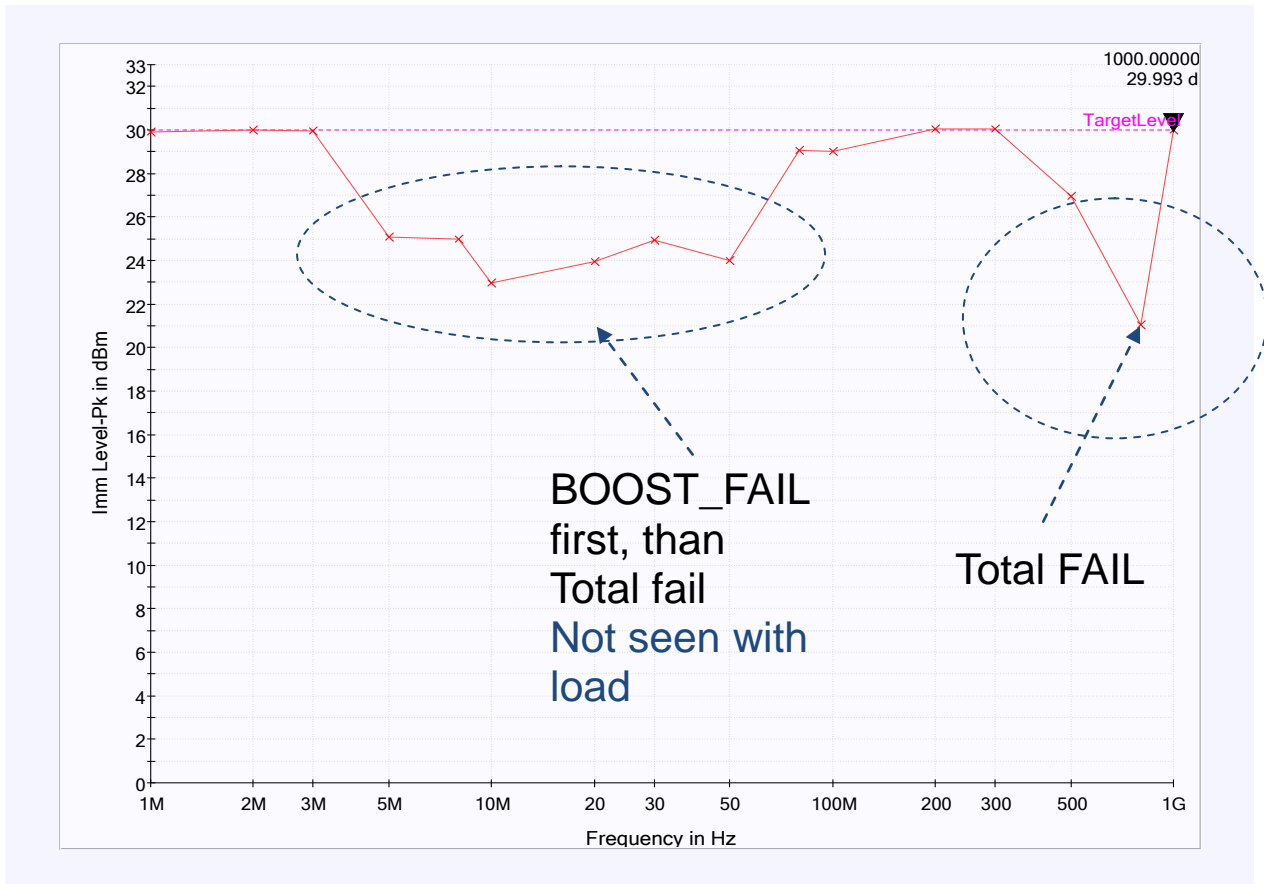

8.24 J25, VIN, CW, Load

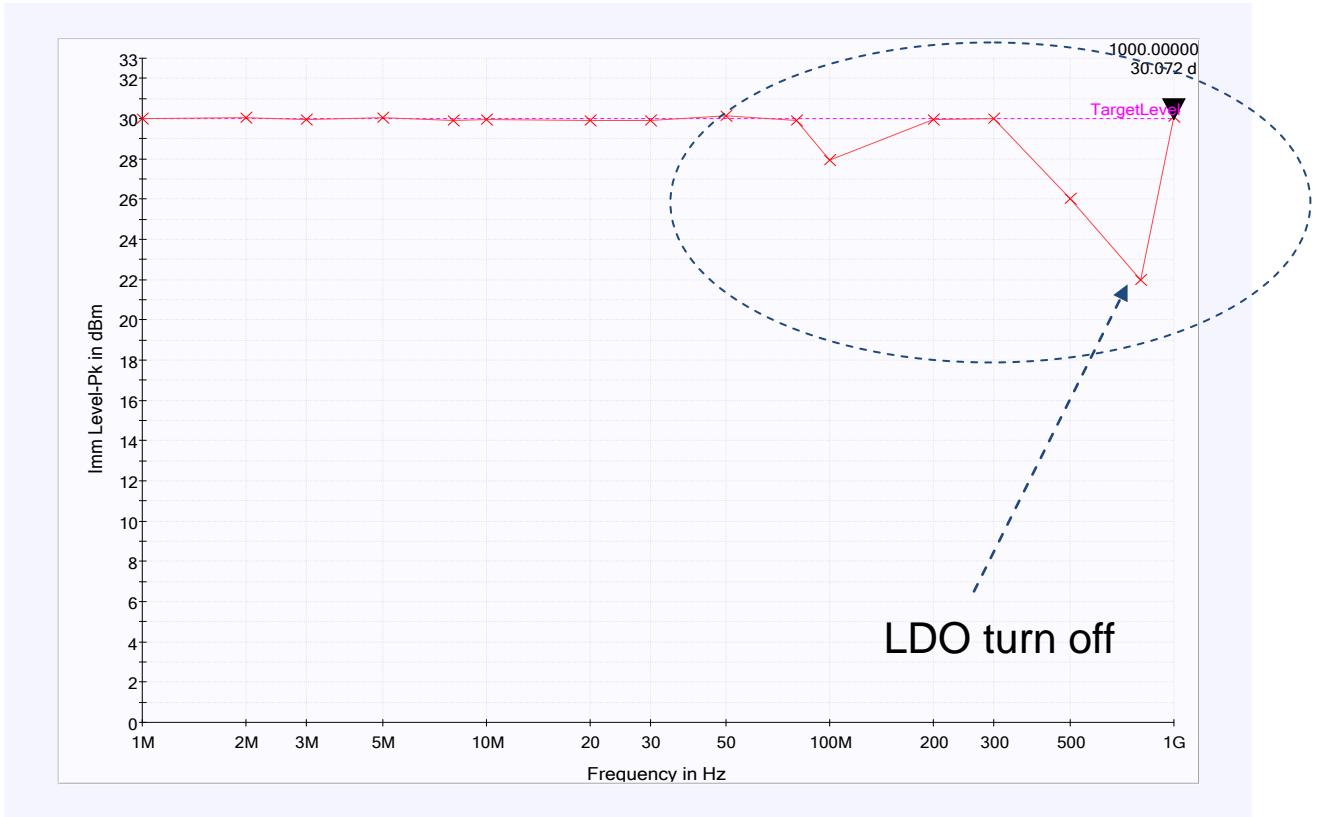

9 DPI Test Summary

- DPI Tests global pins
 - VSSENSE: Minor influence above 300 MHz down to 20 dBm
 - VIN: Minor influence at 100 MHz 28 dBm, above 300 MHz down to 22 dBm
 - WAKE: Minor influence 100 MHz AM down to 29 dBm
 - HSSENSE: No influence
 - With no load condition a difference performance was observed at VI pin at lower frequencies.
- DPI Tests local pins
 - HSCTRL: No influence
 - LDO: Major influence starting at 80 MHz down to 9 dBm @ 300 MHz, not very reproducible, since this is a local pin it might be not critical, verification on ECU level is needed (CAS BCI test).
 - VBOOST: Minor influence above 500 MHz down to 28 dBm
 - VSUPx: Minor influence above 100 MHz, down to 22 dBm
 - S1_BUCK: No influence
- DPI Tests at local pins, internal
 - VMON and VSENSE not testable due to influence of coupling network to normal operation of the application

IMPORTANT NOTICE

Texas Instruments Incorporated and its subsidiaries (TI) reserve the right to make corrections, enhancements, improvements and other changes to its semiconductor products and services per JESD46, latest issue, and to discontinue any product or service per JESD48, latest issue. Buyers should obtain the latest relevant information before placing orders and should verify that such information is current and complete. All semiconductor products (also referred to herein as "components") are sold subject to TI's terms and conditions of sale supplied at the time of order acknowledgment.

TI warrants performance of its components to the specifications applicable at the time of sale, in accordance with the warranty in TI's terms and conditions of sale of semiconductor products. Testing and other quality control techniques are used to the extent TI deems necessary to support this warranty. Except where mandated by applicable law, testing of all parameters of each component is not necessarily performed.

TI assumes no liability for applications assistance or the design of Buyers' products. Buyers are responsible for their products and applications using TI components. To minimize the risks associated with Buyers' products and applications, Buyers should provide adequate design and operating safeguards.

TI does not warrant or represent that any license, either express or implied, is granted under any patent right, copyright, mask work right, or other intellectual property right relating to any combination, machine, or process in which TI components or services are used. Information published by TI regarding third-party products or services does not constitute a license to use such products or services or a warranty or endorsement thereof. Use of such information may require a license from a third party under the patents or other intellectual property of the third party, or a license from TI under the patents or other intellectual property of TI.

Reproduction of significant portions of TI information in TI data books or data sheets is permissible only if reproduction is without alteration and is accompanied by all associated warranties, conditions, limitations, and notices. TI is not responsible or liable for such altered documentation. Information of third parties may be subject to additional restrictions.

Resale of TI components or services with statements different from or beyond the parameters stated by TI for that component or service voids all express and any implied warranties for the associated TI component or service and is an unfair and deceptive business practice. TI is not responsible or liable for any such statements.

Buyer acknowledges and agrees that it is solely responsible for compliance with all legal, regulatory and safety-related requirements concerning its products, and any use of TI components in its applications, notwithstanding any applications-related information or support that may be provided by TI. Buyer represents and agrees that it has all the necessary expertise to create and implement safeguards which anticipate dangerous consequences of failures, monitor failures and their consequences, lessen the likelihood of failures that might cause harm and take appropriate remedial actions. Buyer will fully indemnify TI and its representatives against any damages arising out of the use of any TI components in safety-critical applications.

In some cases, TI components may be promoted specifically to facilitate safety-related applications. With such components, TI's goal is to help enable customers to design and create their own end-product solutions that meet applicable functional safety standards and requirements. Nonetheless, such components are subject to these terms.

No TI components are authorized for use in FDA Class III (or similar life-critical medical equipment) unless authorized officers of the parties have executed a special agreement specifically governing such use.

Only those TI components which TI has specifically designated as military grade or "enhanced plastic" are designed and intended for use in military/aerospace applications or environments. Buyer acknowledges and agrees that any military or aerospace use of TI components which have **not** been so designated is solely at the Buyer's risk, and that Buyer is solely responsible for compliance with all legal and regulatory requirements in connection with such use.

TI has specifically designated certain components as meeting ISO/TS16949 requirements, mainly for automotive use. In any case of use of non-designated products, TI will not be responsible for any failure to meet ISO/TS16949.

Products

Audio	www.ti.com/audio
Amplifiers	amplifier.ti.com
Data Converters	dataconverter.ti.com
DLP® Products	www.dlp.com
DSP	dsp.ti.com
Clocks and Timers	www.ti.com/clocks
Interface	interface.ti.com
Logic	logic.ti.com
Power Mgmt	power.ti.com
Microcontrollers	microcontroller.ti.com
RFID	www.ti-rfid.com
OMAP Applications Processors	www.ti.com/omap
Wireless Connectivity	www.ti.com/wirelessconnectivity

Applications

Automotive and Transportation	www.ti.com/automotive
Communications and Telecom	www.ti.com/communications
Computers and Peripherals	www.ti.com/computers
Consumer Electronics	www.ti.com/consumer-apps
Energy and Lighting	www.ti.com/energy
Industrial	www.ti.com/industrial
Medical	www.ti.com/medical
Security	www.ti.com/security
Space, Avionics and Defense	www.ti.com/space-avionics-defense
Video and Imaging	www.ti.com/video

TI E2E Community

e2e.ti.com