



ABSTRACT

This document is provided with the DRV824x-Q1EVM , DRV814x-Q1EVM, DRV816x-Q1EVM, and DRV826x-Q1EVM customer evaluation module (EVM) as a supplement to the Automotive DRV824x-Q1, DRV814x-Q1, DRV816x-Q1, and DRV826x-Q1 Motor Driver data sheets. This user's guide details the hardware implementation of the EVM and how to install the software packages.

Table of Contents

| | |
|----------------------------------------------------------------------|----|
| 1 Introduction | 2 |
| 1.1 Overview..... | 2 |
| 2 Evaluation Hardware Overview | 3 |
| 2.1 Connections Overview..... | 3 |
| 2.2 Connection Details..... | 3 |
| 2.3 LED Indicators..... | 12 |
| 2.4 Headers and Connectors (Hardware Device Variant)..... | 13 |
| 2.5 Headers and Connectors (SPI variant)..... | 13 |
| 3 EVM GUI Control Application | 14 |
| 3.1 MSP430 FET Drivers..... | 14 |
| 3.2 Cloud-based GUI..... | 15 |
| 3.3 Local Installation..... | 16 |
| 4 EVM GUI Operation | 17 |
| 4.1 Hardware Setup..... | 17 |
| 4.2 Launching the DRV824x_DRV814x_DRV8x63-Q1EVM GUI Application..... | 17 |
| 4.3 Using the DRV824x_DRV814x_DRV8x63-Q1EVM GUI Application..... | 20 |
| 5 Revision History | 26 |

Trademarks

Mac® is a registered trademark of Apple Inc.

Linux® is a registered trademark of Linus Torvalds.

Windows® is a registered trademark of Microsoft Corporation.

All trademarks are the property of their respective owners.

1 Introduction

1.1 Overview

The DRV824x, DRV814x, DRV816x, and DRV826x family of devices are fully integrated H-bridge and half-bridge drivers, respectively, for a wide range of automotive applications. The DRV824x and DRV826x devices can be configured as a single H-bridge driver, or two independent half-bridge drivers. Designed in Texas Instruments' proprietary high-power BiCMOS process technology node, this monolithic die device in a power package offers excellent power handling and thermal capability while providing compact package size, ease of layout, EMI control, accurate current sense, robustness, and diagnostic capability. The DRV824x and DRV814x family of devices have an identical pin function with scalable RDSON (current capability) to support different loads with minimal design changes within the family (H-bridge or half-bridge).

The device integrates an N-channel output stage, charge pump regulator, high-side current sensing and regulation, current proportional output, and protection circuitry. A low-power sleep mode is provided to achieve ultra-low quiescent current draw by shutting down most of the internal circuitry. The device offers voltage monitoring and load diagnostics as well as protection features against output over current and device over temperature. Fault conditions are indicated on the nFAULT pin. The device is available in two interface variants - hardware ("HW") and SPI. The HW variant uses strapping resistors for fixed configuration. The SPI variant offers more flexibility in device configuration and fault observability with an external controller.

1.1.1 Purpose and Scope

This document is designed to be used as a startup guide and to supplement the DRV824x-Q1EVM, DRV826x-Q1EVM, DRV816x-Q1EVM, and DRV814x-Q1EVM ("EVM"). The scope of this document is to provide the user with a guide to evaluate the DRV824x-Q1, DRV826x-Q1, DRV816x-Q1, and/or DRV814x-Q1 device using a Graphical User Interface (GUI). The GUI application is required to control the EVM. This document covers the required EVM connections, configuration, and steps to acquire and use the GUI application for a successful evaluation.

1.1.2 Supported EVMs

Below is a list of all the EVMs which are supported by this document:

1. DRV814x-Q1EVMs
 - a. <https://www.ti.com/tool/DRV8143H-Q1EVM>
 - b. <https://www.ti.com/tool/DRV8143P-Q1EVM>
 - c. <https://www.ti.com/tool/DRV8144H-Q1EVM>
 - d. <https://www.ti.com/tool/DRV8145H-Q1EVM>
2. DRV824x-Q1EVMs
 - a. <https://www.ti.com/tool/DRV8242H-Q1EVM>
 - b. <https://www.ti.com/tool/DRV8242S-Q1EVM>
 - c. <https://www.ti.com/tool/DRV8243H-Q1EVM>
 - d. <https://www.ti.com/tool/DRV8243S-Q1EVM>
 - e. <https://www.ti.com/tool/DRV8244H-Q1EVM>
 - f. <https://www.ti.com/tool/DRV8244S-Q1EVM>
 - g. <https://www.ti.com/tool/DRV8245H-Q1EVM>
 - h. <https://www.ti.com/tool/DRV8245S-Q1EVM>
3. DRV8x63-Q1EVMs
 - a. <https://www.ti.com/tool/DRV8263H-Q1EVM>
 - b. <https://www.ti.com/tool/DRV8263S-Q1EVM>
 - c. <https://www.ti.com/tool/DRV8163H-Q1EVM>
 - d. <https://www.ti.com/tool/DRV8163S-Q1EVM>

2 Evaluation Hardware Overview

CAUTION



Hot surfaces on the EVM include the DRV824x-Q1, DRV826x-Q1, DRV816x-Q1 or DRV814x-Q1 device (U1) and the area surrounding.

When operating the EVM at the maximum device specifications and a high ambient temperature, external cooling fans can be required to minimize potential fire hazard, personal injury, or both.

2.1 Connections Overview

The major blocks of the EVM include the driver (DRV824x-Q1, DRV826x-Q1, DRV816x-Q1, or DRV814x-Q1), MSP430G2553 microcontroller (MCU) controlling the driver, and MSP430F5528 (EZFET_LITE) for UART and JTAG communications over USB.

The EVM is designed for an input supply from 4.5 to 36V at the rated peak drive current for each device (refer to device data sheet). The DRV824x-Q1, DRV826x-Q1, DRV816x-Q1, or DRV814x-Q1 device provides current to a brushed DC motor or other load. The MCU communicates with the GUI via the EZFET_LITE USB to Virtual COM Port (VCP) to control the DRV824x-Q1, DRV826x-Q1, DRV816x-Q1, or DRV814x-Q1 device.

2.2 Connection Details

See [Table 2-1](#) for a brief comparison of the DRV824x-Q1EVM, DRV826x-Q1EVM, DRV816x-Q1EVM, and DRV814x-Q1EVM in the VQFN HotRod™ package. The 28-pin leaded package (HVSSOP or HTSSOP) version of EVM leverages much of the same design and is also covered by this document. From a firmware and GUI perspective, the two package options are interchangeable. The 40x40mm lower-right quadrant of the EVM is modified to the H-bridge and half-bridge devices. The DRV814x-Q1 and DRV816x-Q1 VQFN device orientations are rotated for better power and thermal characteristics, taking advantage of the busbar-like footprint of the HotRod™ package.

A supply voltage ranging from +4.5 VDC to +36 VDC from a battery or a DC voltage source is connected to the voltage supply pins. This connection includes fuse, reverse polarity, and transient protection.

The OUT1 and OUT2 banana jacks on the DRV824x-Q1EVM and DRV826x-Q1EVM can be connected to a brushed motor, inductor, or latched relay coil when used in PWM or phase/enable (PH/EN) mode. When used in independent half-bridge mode, the OUT1 pin can drive one load and the OUT2 pin can drive a second load.

Table 2-1. DRV814x-Q1EVM, DRV816x-Q1EVM, DRV826x-Q1EVM, and DRV824x-Q1EVM Comparison

| <i>DRV814x-Q1EVM and DRV16x-Q1EVM</i> | <i>DRV824x-Q1EVM and DRV826x-Q1EVM</i> |
|------------------------------------------------------------------------------------------------------------------------------------------------------------------|---------------------------------------------------------------------------------------------------------------------------------------------------------------------------------------|
| <ul style="list-style-type: none"> • Single half-bridge output in VQFN HotRod™ package • SPI and Hardware control variants | <ul style="list-style-type: none"> • H-bridge/ dual independent half-bridge outputs in VQFN HotRod™ package • SPI and Hardware control variants |
| | |

Note

DRV8242 does not support independent half-bridge mode

2.2.1 Common Connectors and Headers Across all EVM Variants

Figure 2-1 shows a larger view of the DRV824x-Q1EVM. Because the DRV814x-Q1EVM, DRV816x-Q1EVM, and DRV824x-Q1EVM share much of the same design, only the DRV824x-Q1EVM is referenced.

The micro-USB connection at the top of the EVM is used for GUI communications, and MCU firmware updates. Main supply input A supply voltage ranging from +4.5 VDC to +36 VDC from a battery or a DC voltage source is connected to the large screw terminal block (fused and reverse polarity protection).

Connect the bi-directional brushed-DC motors to the OUT1 and OUT2 banana jacks. Ground and VM supply connections are provided as a convenience for high-side or low-side switched loads (for example, unidirectional brushed DC motor or solenoid).

Note

VM has a small voltage drop with respect to the main supply due to the N-channel MOSFET in the reverse protection circuit.

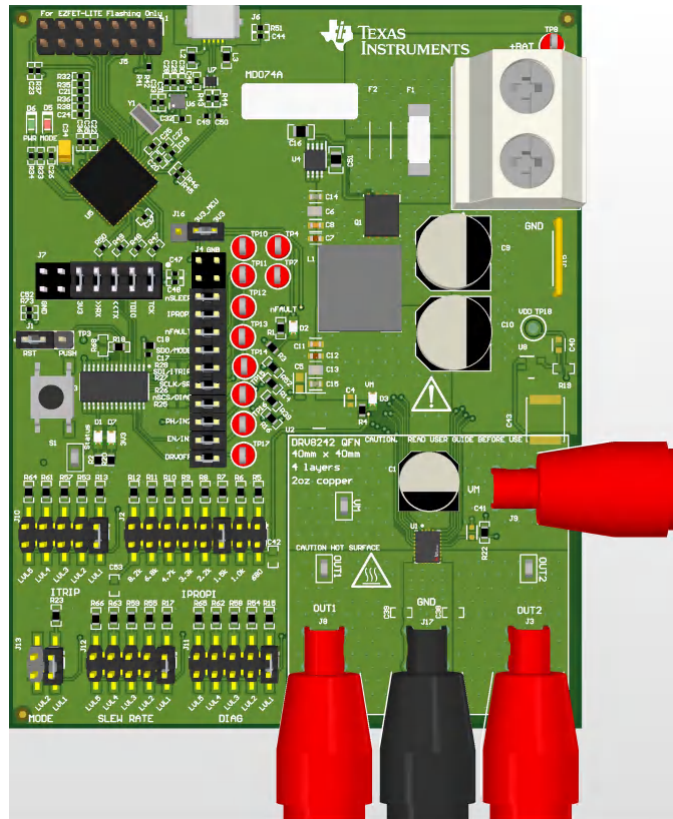

Figure 2-1. DRV824x-Q1EVM

2.2.2 MCU Reset and User Button

The small tactile push button is typically used to reset the MCU [Figure 2-2](#). Typically resetting the MCU is not necessary, however, the MCU automatically clears the nFAULT indicator on initial power-up if the user finds the fault indicator is set due to cycling the power on the external supply. This is normal (nFAULT always comes up asserted on the DRV824x and DRV814x devices).

A jumper is installed shorting pins 1 and 2 on header J1 for the MCU reset function. If a firmware reset is necessary, then the push button is pressed once and released. Following a reset, a proper startup is indicated by the blinking STATUS LED. If the jumper is moved to pins 2 and 3 on J1, then this routes the button to a spare GPIO pin on the MSP430 MCU, and can be used for personal purposes in the firmware. Beginning with version 0.22 of the firmware, an interrupt subroutine (ISR) has been assigned to this GPIO input, and automatically puts the DRV824x device in PH/EN mode, and energizes the output OUT1 terminal (or OUT terminal of the DRV814x device) at 25% duty cycle on the first press of the User button with a 12V power supply connected to the connector J14, BAT+ and GND screw terminals and the Micro-USB connected. Pressing the button again disables the output. This can be repeated with the same on/ off behavior. The user can connect a brushed DC motor across OUT1 and OUT2 terminals of the DRV824x and DRV826x EVM or OUT and GND of the DRV814x and DRV816x EVM, or simply an oscilloscope.

Note

No diagnostics are enabled in this simple test case – open load detection is not active

When in this test mode, the STATUS LED (D1) is fully on when the output is active, and returns to approximately 1Hz blinking when the output is off with an SPI EVM or an approximately 0.1 Hz blinking with an HW EVM. After completion of the standalone EVM testing, TI recommends positioning the jumper settings back to pins 1 and 2.

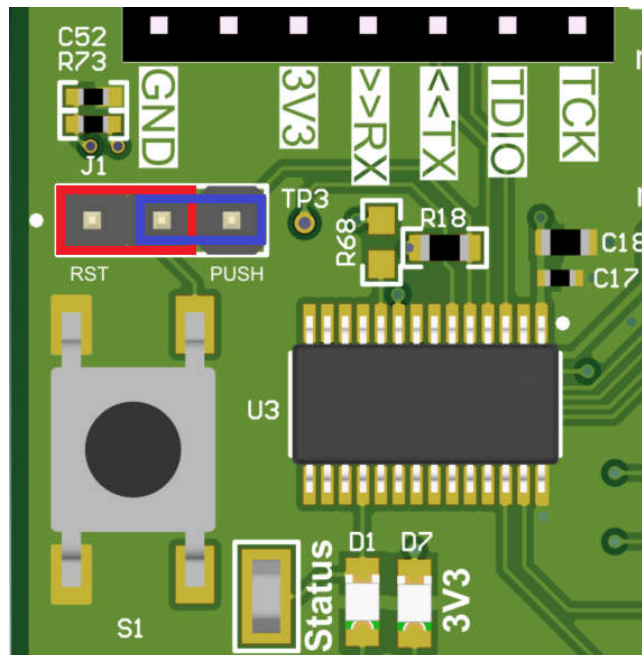

Figure 2-2. MCU Reset and User Button

2.2.3 Communication Interfaces

The micro-USB connection is the primary communication interface from your PC to the EVM GUI Application. [Figure 2-3](#) illustrates connection associated with communications between the EVM and GUI, as well as firmware programming (some components have been removed from the picture for clarity).

The EZFET_LITE (based on the Texas Instruments MSP430F5528) is programmed at the factory with firmware that implements UART and JTAG over USB.

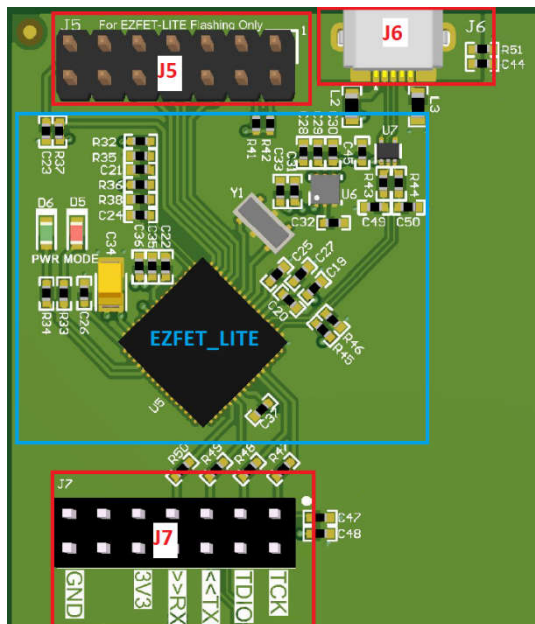

Figure 2-3. EVM Communication Connections

[Table 2-2](#) describes each communication connection.

Table 2-2. Communication Description

| Designator | Description |
|------------|-------------------------------------------------------------------------------------------------------------------------------------------------------|
| J5 | MSP430 14-pin JTAG interface. Used for programming EZFET_LITE firmware on MSP430F5528 during manufacturing and not used during normal user operation. |
| J6 | Micro-USB interface for main MCU (MSP430G2553). Both UART and JTAG are routed over this connection. |
| J7 | These headers route communications and 3.3V to the main MCU. Jumpers must be installed on 3V3, RX, TX, TDIO, and TCK positions. |

2.2.4 Supply Input

Figure 2-4 illustrates the portions of the EVM associated with the main supply input powering the DRV824x-Q1, DRV826x-Q1, DRV814x-Q1, or DRV816x-Q1 device, and the associated loads. Starting from the upper-left, and working clockwise around the image:

- Supply reverse polarity protection. The Texas Instruments LM74610QDGKRQ1 drives a Texas Instruments CSD18513Q5A 40V 100 A N-channel MOSFET.
- Fuses.

Note

DRV8243-Q1 and DRV8263-Q1 EVMs only have a single fuse populated

- Not pictured (underside): TVS diode.
- High current supply input with screw terminals. The supply shall be between +4.5VDC to +36V. Test points are provided.
- Pi filter section comprising two 50V 150uF capacitors and a 1mH inductor (misc. passive components omitted from image for simplicity).

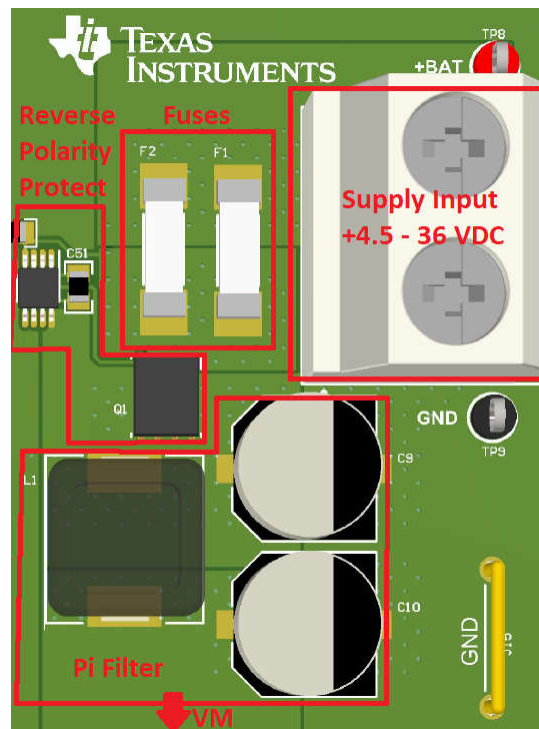

Figure 2-4. Main Supply Section

2.2.5 Current Limit Header (RIPROPI)

The DRV824x, DRV826x, DRV814x, and DRV826x family of devices integrate a current sense output using current mirrors on the low-side power MOSFETs on the IPROPI device pin. The IPROPI pin sources a small current proportional to the current in the high-side MOSFETs (current sourced out of the IPROPI pin). The IPROPI current can be converted to a proportional voltage using an external resistor (R_{IPROPI}). The integrated current sensing allows the DRV824x and DRV814x devices to limit the output current with a fixed off-time PWM chopping scheme and provides load information to an external controller to detect changes in load or stall conditions. The integrated current sensing outperforms traditional external shunt resistor sensing by providing current information even during the off-time slow decay recirculating period. Additionally, BOM cost and PCB area are reduced by eliminating a large external power shunt resistor. The off-time PWM current regulation level can be configured during motor operation through the ITRIP function to limit the load current according to the system's demands.

Selecting the R_{IPROPI} value must be done in conjunction with the ITRIP level (configured through SPI or external jumper selection depending on SPI or hardware device variant) and is governed by the following relationship:

$$ITRIP \text{ (AMPS)} = V_{ITRIP_LVL} / R_{IPROPI} * A_{IPROPI} \tag{1}$$

Example: (Typical values from DRV8245-Q1 data sheet; A_{IPROPI} vary by part number):

| | |
|--------------------------------------------|-----------------------------------------------|
| $V_{ITRIP_LVL6} = 2.97V$ | $ITRIP = \frac{2.97V}{1000\Omega} * 6600 A/A$ |
| $R_{IPROPI} = 1000\Omega$ | |
| $A_{IPROPI} = 6600 A/A$ (DRV8245, DRV8145) | $ITRIP = 19.6A$ |

Refer to the *Electrical Characteristics CURRENT SENSE AND REGULATION* table in the device data sheet for R_{IPROPI} values matching the output capability of the device installed on your EVM.

Figure 2-5 shows the header with user-selectable R_{IPROPI} values.

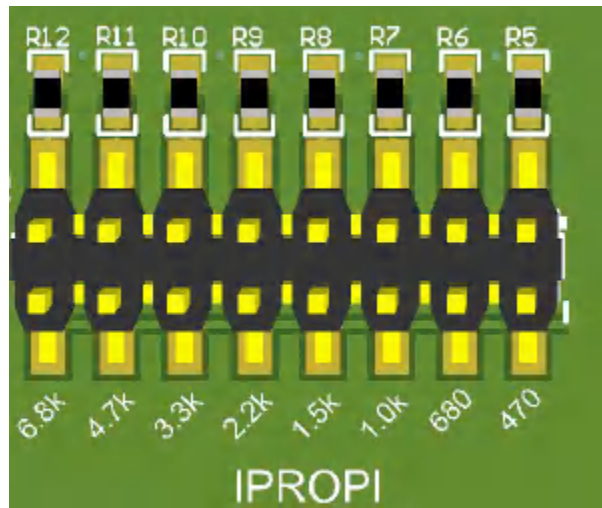

Figure 2-5. R_{IPROPI} Header

2.2.6 Device Signal and Control Header

The J4 header [Figure 2-6](#) is provided for users who want to interface an external control design and is also a convenient means for probing all device control signals. When interfacing with an external control design, remove the associated 0ohm resistors immediately adjacent to the silk screen label.

Note

PH/IN2 signal is not present on DRV814x-Q1EVM or DRV816x-Q1 EVM variants. Refer to the EVM schematic for more details.

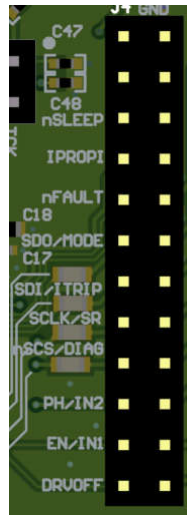
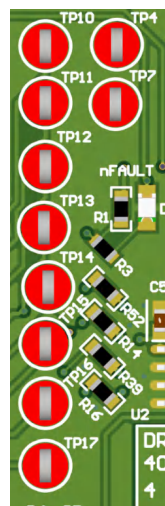

Figure 2-6. DRV824x-Q1EVM Signal and Control Header

2.2.7 Device Signal Test Points

The signals corresponding to each test point for both the hardware and SPI variant is given below for each of the devices. The naming convention for the test points is as follows: SPI/ HW. The signal on the test point for the SPI versions of the devices is listed first and then the HW variant.



| Test Point number | DRV824x | DRV8145 |
|-------------------|-----------|-----------|
| TP4 | nSLEEP | nSLEEP |
| TP7 | IPROPI | IPROPI |
| TP10 | nFAULT | nFAULT |
| TP11 | SDO/MODE | SDO/MODE |
| TP12 | SDI/ITRIP | SDI/ITRIP |
| TP13 | SCLK/SR | SCLK/SR |
| TP14 | nSCS/DIAG | nSCS/DIAG |
| TP15 | PH/IN2 | N/A |
| TP16 | EN/IN1 | EN/IN1 |
| TP17 | DRVOFF | EN/IN1 |



| Test Point number | DRV8144 |
|-------------------|-----------|
| TP3 | nSLEEP |
| TP4 | IPROPI |
| TP5 | nFAULT |
| TP7 | SDO/NC |
| TP10 | SDI/ITRIP |
| TP11 | SCLK/SR |
| TP12 | nSCS/DIAG |
| TP13 | IN |
| TP14 | DRVOFF |

2.3 LED Indicators

Figure 2-7 shows the physical location of each LED indicator on the EVM. Placement is the same for all EVMs in the family.

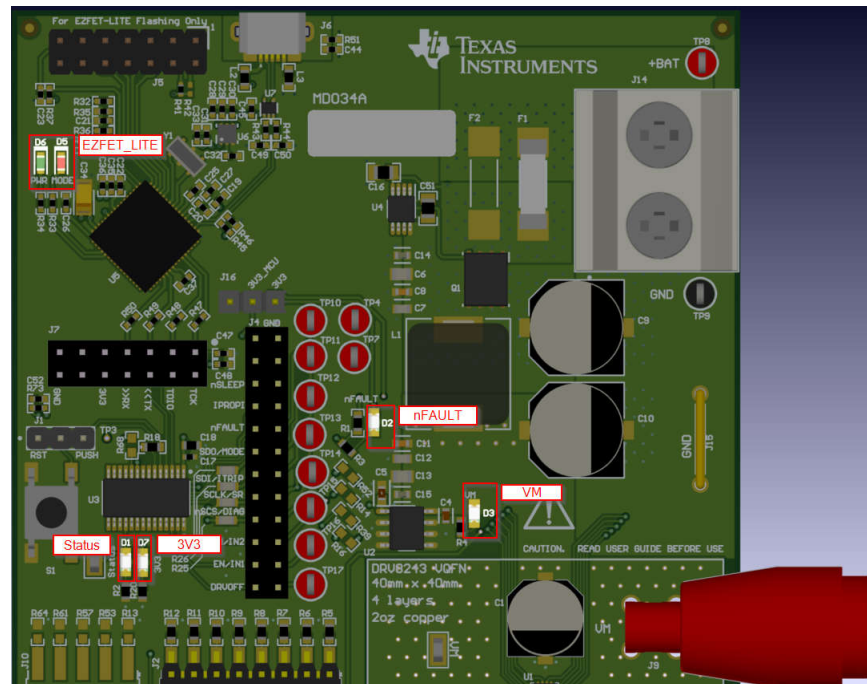

Figure 2-7. EVM LED Indicators

Refer to Table 2-3 for descriptions of each LED on the EVM.

Table 2-3. EVM LED Indicators and their Functions

| Designator | Label | Description |
|------------|--------|-------------------------------------------------------------------------------------------------------------------------------------------------------------------------------------------------------------------------------------------------------------------------------------------------------------------------------|
| D1 | Status | Indicates MCU execution and DRV status. Flashing approximately 0.1Hz: DRV in sleep mode Flashing approximately 1Hz: DRV ready, outputs disabled Continuously on: DRV output enabled/ active Alternating with nFAULT: MCU abort exception This LED flashes continuously until the VM power supply is turned on. |
| D2 | nFAULT | Indicates fault condition. Normally off. To briefly see this LED flash when the MCU becomes active or RESET is pressed is normal. |
| D3 | VM | VM supply indicator. Normally if supply is connected to +BAT input. |
| D5 | MODE | EZFET_LITE mode indicator. Normally on during GUI control. On/ flashing when using the JTAG interface. |
| D6 | PWR | EZFET_LITE power indicator (must be active for GUI control). |
| D7 | 3V3 | 3.3V for MCU (must be active for GUI control). |

2.4 Headers and Connectors (Hardware Device Variant)

Figure 2-8 shows all configuration jumpers for the DRV824xH-Q1 hardware variant. DRV814xH-Q1 features the same jumpers, with the exception of *MODE*. Each LVL silkscreen label directly corresponds to the data sheet description. Changing the jumper within *MODE* allows the user to use the driver in PH/EN, PWM, and Independent Half-Bridge mode. Please refer to the device data sheet for more information regarding pin LVL settings and associated configuration.

Note

IPROPI is common to both hardware and SPI EVM/ device variants and performs the same function.

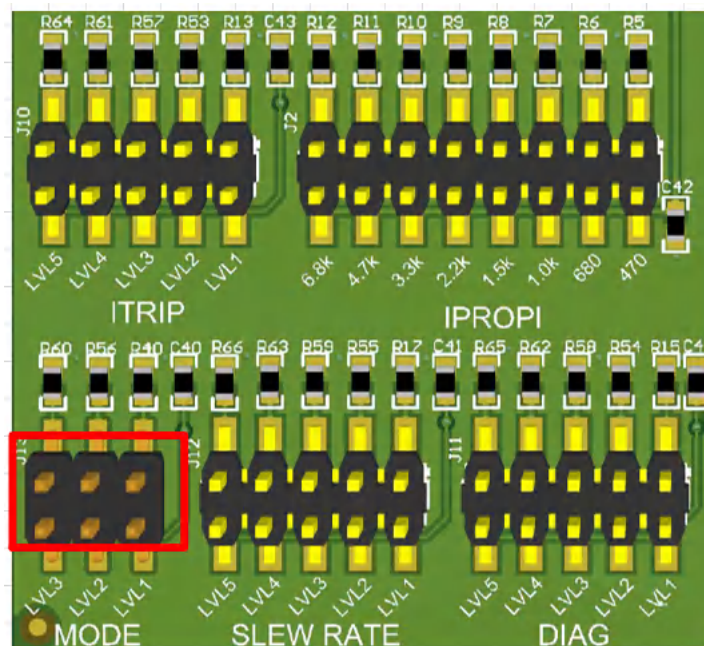

Figure 2-8. DRV824x and DRV814x Hardware Variant Configuration Jumpers

2.5 Headers and Connectors (SPI variant)

The and DRV824xS-Q1, DRV826xS-Q1, DRV814xS-Q1, and DRV816xS-Q1 SPI device variants omit all headers associated with the hardware variant described in the previous section.

3 EVM GUI Control Application

The GUI application is written with Texas Instruments' GUI Composer, and can be run directly from a Chrome-based web browser, or installed onto your computer. Because GUI Composer apps are written with a NodeJS back end, the GUI application is cross-platform compatible by design. This document only covers installation on a PC for sake of brevity, but Mac® and Linux® users can find installers in the [GUI Composer Gallery](#).

3.1 MSP430 FET Drivers

The MSP430 FET Drivers are required for the operating system to properly enumerate the JTAG and UART ports created by the EZFET_LITE. The latest drivers can be found here: [MSP430 FET Drivers](#)

Download the driver package corresponding to your operating system, extract the archive, and run the installer.

In Windows®, two new ports must be enumerated when the EVM is connected [Figure 3-1](#):

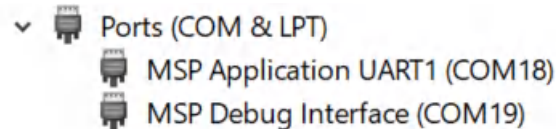

Figure 3-1. MSP430 EZFET_LITE Enumerated USB Ports

Successful installation also shows Texas Instruments as the driver publisher ([Figure 3-2](#)):

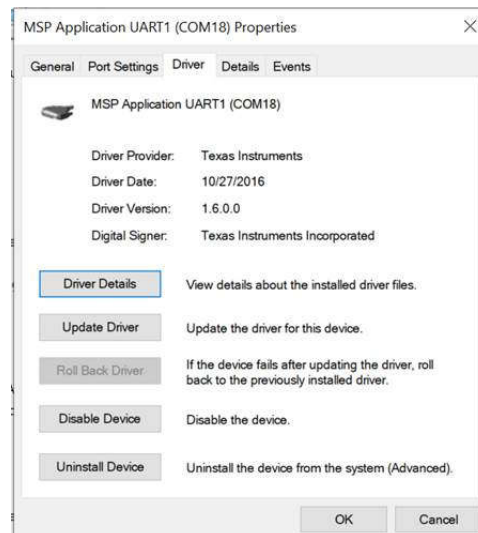

Figure 3-2. MSP Application UART Driver Properties

3.2 Cloud-based GUI

To launch the GUI application from Chrome browser:

1. For the DRV824x and DRV814x devices, navigate to the [DRV824x_DRV814x-Q1EVM-GUI](#). For the DRV826x and DRV816x devices, navigate to the [DRV824x_DRV814x_DRV8x63-Q1EVM-GUI](#).
2. When presented with the list of available GUIs, launch the latest version by clicking in the tile anywhere that is not related to an icon for downloading the installer or GUI Composer. Refer to the figure below.



Figure 3-3. TI GUI Composer Gallery Results for Launching or Downloading Local Installer

Hardware setup and operation of the GUI is the same as the desktop version, and is consolidated in the following [Section 4](#).

3.3 Local Installation

Follow these instructions for downloading and installing the latest version of the EVM GUI application:

1. The EVM GUI application installer can also be downloaded from the [TI GUI Composer Gallery](#).
2. From the gallery, click the  icon in the latest version and select the installer for your operating system (Windows, Linux or Mac). Refer back to in the previous section for a visual depiction of the Gallery page.
3. Decompress the .zip file.
4. From the decompressed archive, run the installer: for example, "DRV824x_DRV814x_DRV8x63-Q1EVM-GUI-1.2.0.setup-win" (refer to [Figure 3-4](#)). If the GUI Composer Runtime has not been installed, then the installer takes care of this. The installer contents looks slightly different for each OS, but is self-explanatory.

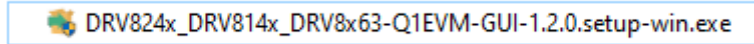

Figure 3-4. GUI Application Archive Contents

5. The GUI application is now ready to run on the local machine after completing the hardware setup in the next section.

4 EVM GUI Operation

4.1 Hardware Setup

Follow these steps to setup the EVM before launching the GUI:

1. TI recommends making any jumper configuration changes prior to powering the EVM. The hardware device variant latches MODE, SLEW RATE, and DIAG jumper settings after power-up and coming out of sleep (however, ITRIP takes effect immediately).

For the SPI device variant, TI recommends making the IPROPI selection before powering the EVM.

2. Connect micro-USB cable to J6 ([Figure 2-3](#)). The digital portion of the EVM becomes active. LEDs D6 and D7 illuminate. The nFAULT LED D2 can blink at a fast rate to indicate the absence of a VM power supply. For proper GUI application operation, connecting the EVM USB cable to a computer before applying +BAT power to the EVM is important. For standalone EVM testing, a USB connection is not necessary.
3. With the +BAT external supply outputs disabled, connect +BAT supply to the screw terminals on the EVM (J14), observing polarity ([Figure 2-4](#)).
4. Energize the +BAT supply. VM LED D3 illuminates. If the VM LED does not illuminate, then verify polarity and check fuses are installed and have continuity. Power consumption is on the order of 10mA @ +12VDC input. Significantly higher or lower can indicate a hardware problem if the fuse and supply polarity are correct.
5. The EVM is ready to be used with the GUI application ([Section 4.2](#)). In certain situations, such as while disconnecting and reconnecting VM power before the power supply capacitors are fully discharged a proper firmware reset does not happen. A proper reset is indicated by the STATUS LED D1 blinking at a rate of approximately 1Hz for the SPI variant EVMs and approximately 0.1Hz for the HW variant EVMs. If the Status LED is not blinking as expected, then press the reset push button once with jumper J1 installed in the RST position. Do not unplug the USB cable while the VM power is active. If the USB cable is unplugged, then switch off the VM power, wait until the power is fully discharged, and proceed to step 2.
6. The latest version of the GUI application is bundled with the latest version of the EVM firmware. TI recommends to do a firmware update before selecting and connecting to an EVM variant using the GUI application. The firmware update procedure is described in [Section 4.3.4](#).

4.2 Launching the DRV824x_DRV814x_DRV8x63-Q1EVM GUI Application

Whether using the desktop or web version of the GUI, the user experience and steps covered below is the same. These steps assume the hardware setup steps in the previous section have already been completed.

1. Launch the GUI application
2. From the screen referenced in [Figure 4-1](#), select the EVM variant connected using the icons on the right.

Note

The 'S' and 'H' part number decorators – these indicate either the SPI or Hardware variant of the device.

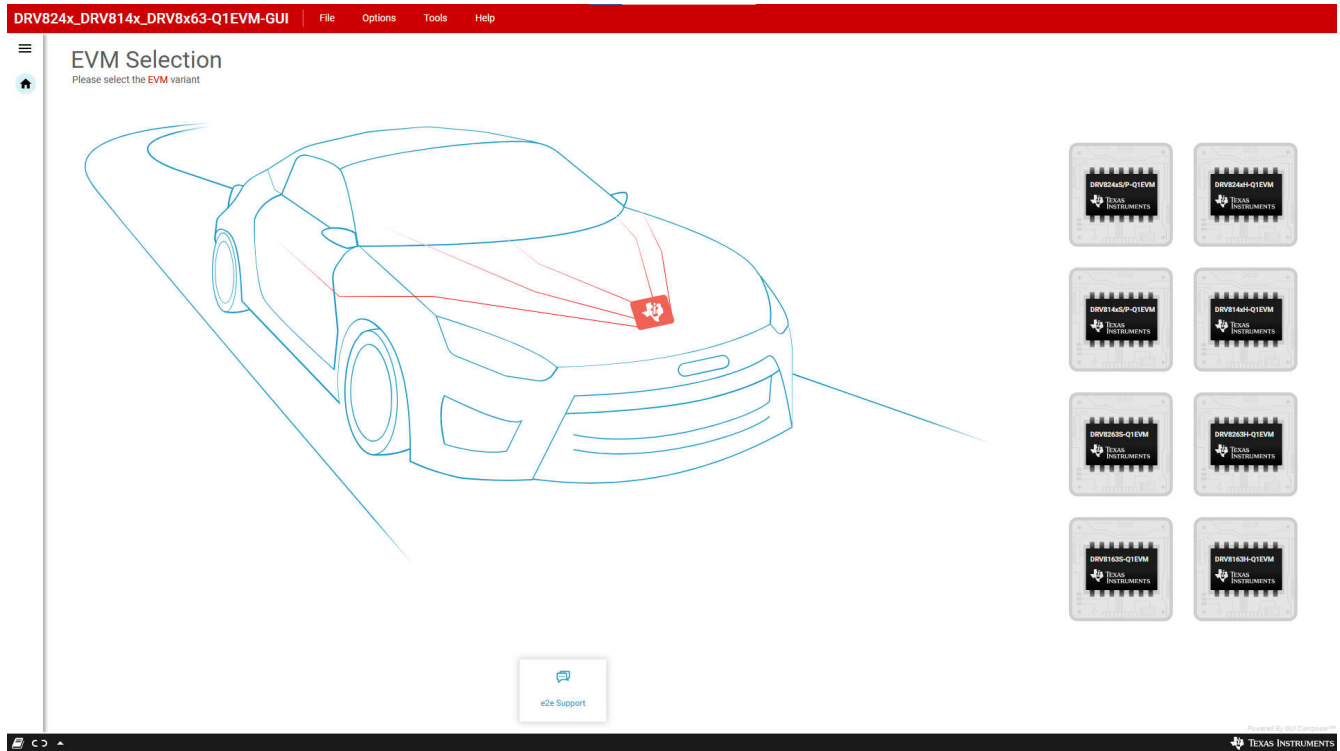

Figure 4-1. DRV824x_DRV814x_DRV8x63-Q1EVM GUI Home Screen

- After clicking the correct EVM type, the GUI application initiates communications with the EVM. Connection confirmation is displayed as shown below in [Figure 4-2](#):

Note

If the EVM GUI does not register a successful connection after multiple attempts do a firmware update and then select an EVM variant for connecting using the GUI application.

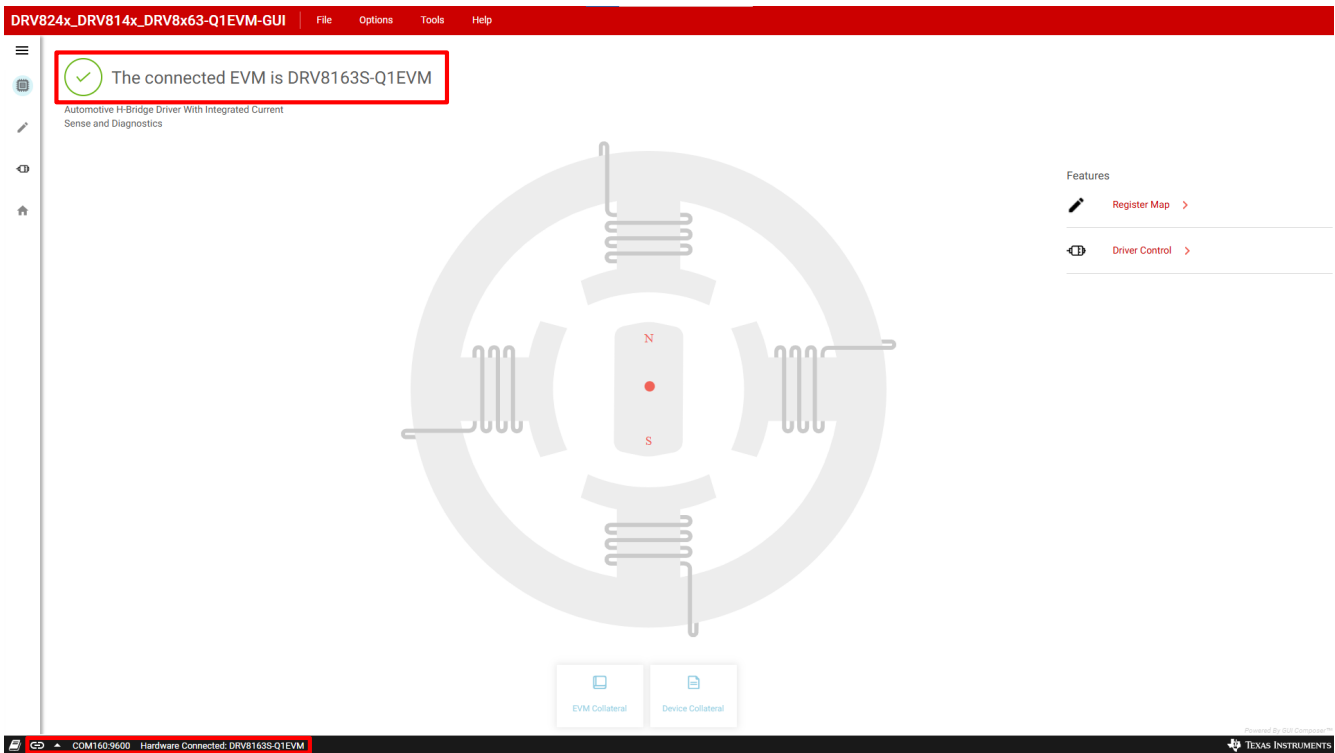

Figure 4-2. Successful EVM Connection

4. At this point, the user sets-up the EVM for device evaluation:
- Register Map page for the SPI device variants for read/ write access of register bit fields.
 - Driver Control page with configuration and diagnostic options.
 - GUI Home page to re-select the EVM if necessary.

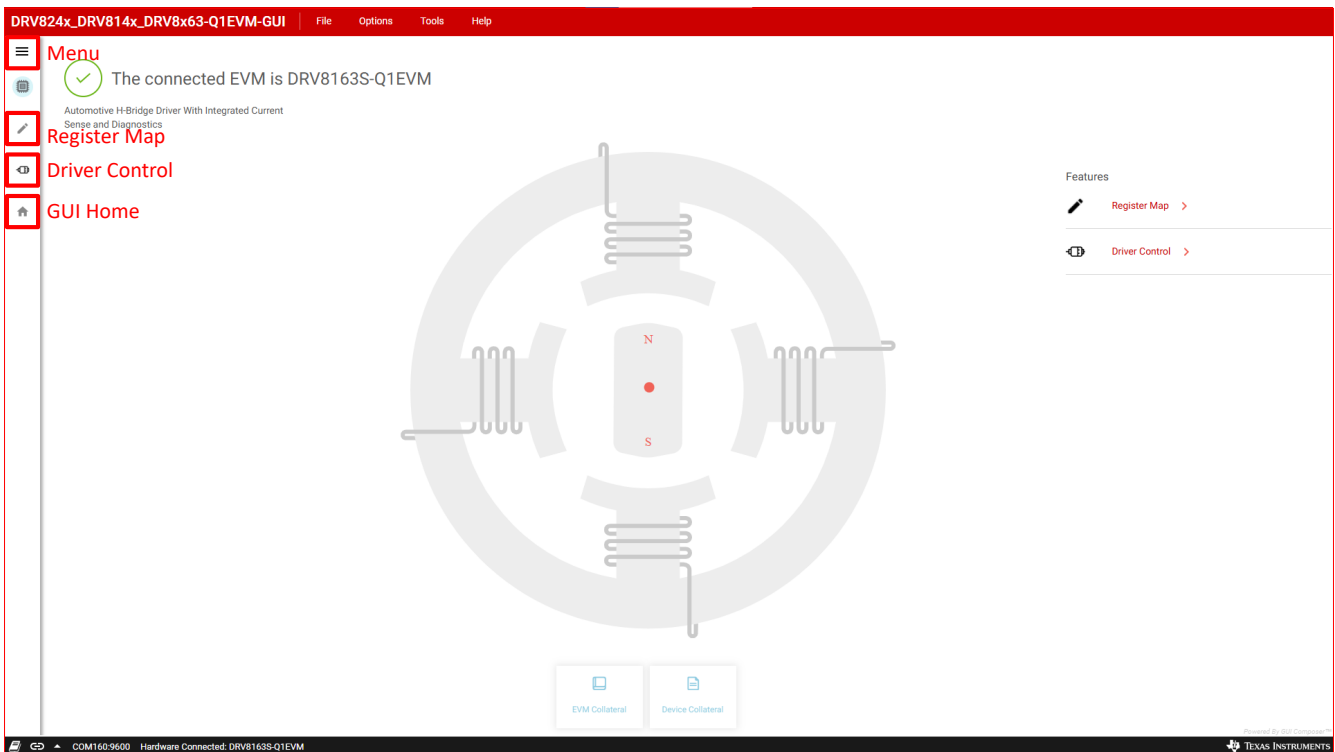

Figure 4-3. DRV824x_DRV814x_DRV8x63-Q1EVM GUI Navigation

4.3 Using the DRV824x_DRV814x_DRV8x63-Q1EVM GUI Application

4.3.1 Register Map Page (SPI Device Variant)

The Register Map page shown below in Figure 4-4 allows the user to read/ write values to individual fields. Register read-back is read "Every 1sec" by default. Enabling this starts periodically polling the device registers. "Off " mode enables a manual read. Auto-read set to "off" is helpful for reducing SPI chatter when using a logic analyzer or performing EMC measurements.

| Register Name | Address | Value | 7 | 6 | 5 | 4 | 3 | 2 | 1 | 0 |
|----------------|---------|-------|---|---|---|---|---|---|---|---|
| STATUS | | | | | | | | | | |
| DEVICE_ID | 0x00 | 0x24 | 0 | 0 | 1 | 0 | 0 | 1 | 0 | 0 |
| FAULT | 0x01 | 0x00 | 0 | 0 | 0 | 0 | 0 | 0 | 0 | 0 |
| STATUS1 | 0x02 | 0x00 | 0 | 0 | 0 | 0 | 0 | 0 | 0 | 0 |
| STATUS2 | 0x03 | 0x00 | 0 | - | 0 | 0 | - | 0 | 0 | 0 |
| CONTROL | | | | | | | | | | |
| COMMAND | 0x08 | 0x00 | 0 | - | - | 0 | 0 | - | 0 | 0 |
| SPLIN | 0x09 | 0x0C | - | - | - | - | 1 | - | - | 0 |
| CONFIG1 | 0x0A | 0x10 | 0 | 0 | 0 | 1 | 0 | 0 | 0 | 0 |
| CONFIG2 | 0x18 | - | 0 | 0 | 1 | 1 | 1 | 0 | 0 | 0 |
| CONFIG3 | 0x0C | 0x40 | 0 | 1 | 0 | 0 | 0 | 0 | - | - |
| CONFIG4 | 0x0D | 0x00 | 0 | 0 | 0 | 0 | 0 | 0 | 0 | 0 |

Figure 4-4. SPI device variant Register Map Page

4.3.2 Driver Control Page (SPI Device Variant)

Figure 4-5. Driver Control Page

Starting from left to right in Figure 4-5:

- **WAKE:** The wake widget controls the nSleep device which directly controls the nSleep pin. The user cannot switch between modes when the device is asleep in SPI mode, and the default for the SPI variant is *awake*.
- **ENABLE DRIVER:** Directly controls the DRVOFF pin. When the bridge control is active, the user cannot change between modes or observe the passive diagnostics.
- **MODE:** Programs the S_MODE register and alters the appearance of the **BRIDGE CONTROL** depending on your selection. There is a difference in **MODE** options between the DRV824x, DRV826x, DRV814x , and DRV816x device families. The DRV814x and DRV816x devices only operate in one fixed mode where the

user can only switch between high side and low side load connections. The high side connection connects the load between VM and OUT while the low side connection connects the load between OUT and GND as can be seen in Figure 4-6.

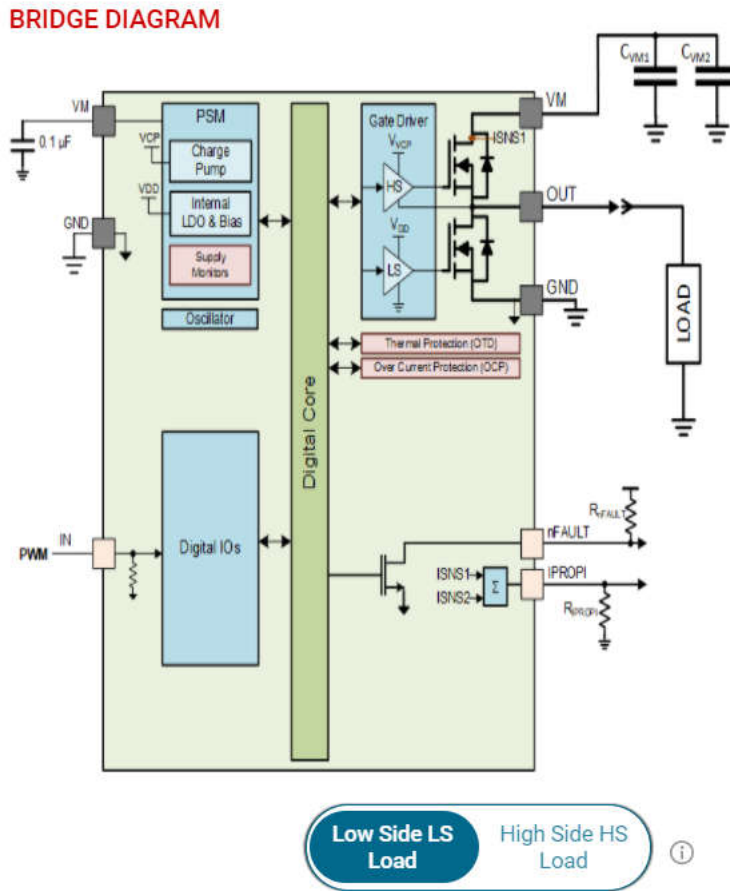

Figure 4-6. DRV814x and DRV816x High Side and Low Side Connections

In the DRV824x and DRV826x devices, Phase/Enable mode only has one duty cycle slider while the Independent Half-bridge mode and PWM mode each have two sliders.

When changing between modes, there is a *Load Connection Warning* popup. If the load is incorrectly connected and the user attempts to run the motor on the GUI, then the load can damage the device and cause harm to the user. This is especially important when in Independent Half-Bridge mode. The load connection warning appears every time the user selects a new mode or repeatedly selects the current mode. Figure 4-7 shows the pop-up window for the Independent Half-Bridge mode selection.

Note

With the DRV824x and DRV826x devices, the GUI allows to switch between high side and low side load connection only using the Independent Half-Bridge mode selection pop-up window.

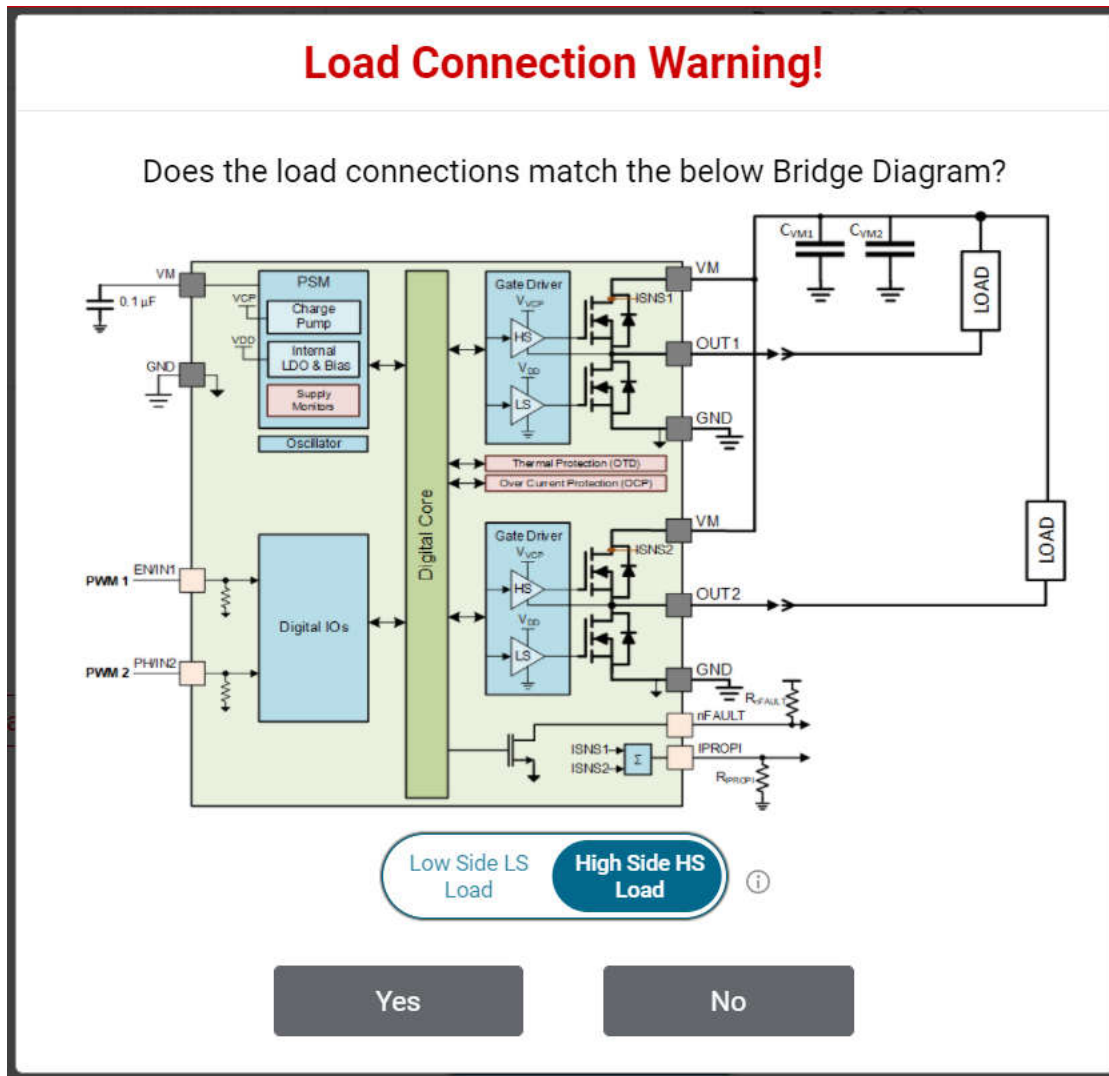



Figure 4-7. DRV824x and DRV826x Independent Half-Bridge Mode High Side and Low Side Load Connection

Note

DRV824x-Q1EVMs with HVSSOP package driver device has OUT1 and OUT2 silk screen labels interchanged.

- **BRIDGE CONTROL** The Start Drive button allows the software state machine to start running on the MCU. Prior to starting, the user can tweak the desired direction, ramp rate, slew rate, and check for properly



connected load connections. After pressing , the duty cycle sliders become available for modification. The output automatically soft-starts using the Ramp Rate parameter.

- **PASSIVE/ACTIVE DIAGNOSTICS** The SPI variant features both passive and active diagnostics. The passive diagnostics also known as Off-line Passive (OLP), can only be used when **ENABLE DRIVER** is disabled (Off-state). OLP shows up in a separate pop-up window as can be seen in [Figure 4-8](#). A representative table from the device data sheet is displayed in this window for guidance to perform the passive diagnostics. Each row of the table covers a specific combination of user input selection, the corresponding OLP setup and load status inference from the OLP_CMP comparator output on the nFAULT pin. See the device data sheet for more details. The required S_DIAG selection can be made using the GUI for SPI devices. The required DIAG jumper setting must be done when **WAKE** is Asleep for HW devices prior to enabling passive diagnostics. The nSLEEP and DRVOFF inputs are logic 1 while observing passive diagnostics. Inputs for EN/IN1 and PH/IN2 are selected using the switches in the GUI. The pull up can take a few seconds, pull down resistors,

and the OLP_CMP output status to update due to the latency between the EVM hardware and the GUI application.

Off-state(Passive) Diagnostics

X

| Off-state (Passive) diagnostics table - PH/EN or PWM mode (Full Bridge) | | | | | | | | | | | |
|-------------------------------------------------------------------------|--------|--------|--------|------------|---------|-----------|---------------|--------------------------------|------|-----------|----------|
| USER INPUTS on PIN / Register bits | | | | OLP SET UP | | | | OUTPUT on nFAULT / OLP_CMP bit | | | |
| nSLEEP | DRVOFF | EN/IN1 | PH/IN2 | OUT1 | OUT2 | CMP REF | OUTx Selected | Normal | Open | GND Short | VM Short |
| 1 | 1 | 1 | 0 | ROLP_PU | ROLP_PD | VOLP_REFH | OUT1 | 0 | 1 | 0 | 1 |
| 1 | 1 | 0 | 1 | ROLP_PU | ROLP_PD | VOLP_REFL | OUT2 | 1 | 0 | 0 | 1 |
| 1 | 1 | 1 | 1 | ROLP_PD | ROLP_PU | VOLP_REFL | OUT2 | 1 | 1 | 0 | 1 |

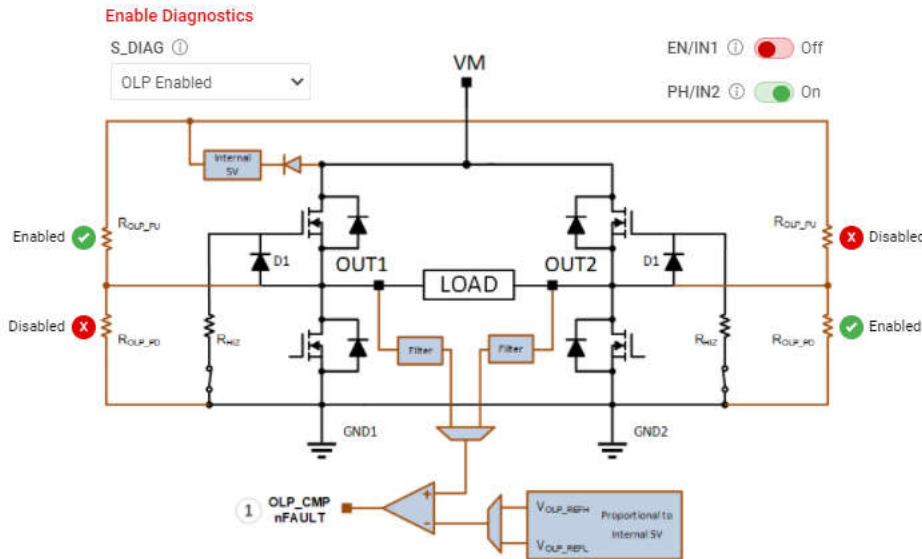

Figure 4-8. Passive Diagnostics Pop-Up Window

The Active Open Load Diagnostics are only for High-Side loads with the DRV824x and DRV826x device, Independent Half-Bridge mode, and the DRV814x and DRV816x Half-Bridge device. The Active Diagnostics not exist in the Hardware variants.

- **FAULTS** Press the clear button to clear all the latched faults. Next to the clear button is the **CONFIG** button for SPI variants. This button allows the user to have more control over the modification of fault reporting. For example, selecting **Automatic Retry** allows the faults to clear without any manual interference.
- **BRIDGE CURRENT** The Bridge Current displays moving average and cycle peak load current values calculated from a window of samples of the voltage V_{IPROPI} ($V_{IPROPI} = R_{IPROPI} \times I_{PROPI}$) on the IPROPI output. Each periodic window of samples is referred to as a cycle. The samples are captured using the integrated 10-bit analog to digital converter in the MCU of the EVM. The displayed values are only indicative of the load current during the sampling window. The IPROPI analog output pin available on the header J4 of the EVM can be used for accurate real-time measurement using a multimeter or for capturing the load current waveform using an oscilloscope. Current scaling is done by selecting a desired R_{IPROPI} resistor with the IPROPI jumper setting on the current limit header J2 of EVM. See Section 2.2.5. Match the R_{IPROPI} setting on the GUI with the IPROPI jumper setting of the EVM.

Note

A possibility is that the bridge current can show a value of 10's of mA for the moving average and cycle peak display in the GUI even with no motor connected while the bridge is enabled and the PWM output set with a non-zero duty cycle value. This is due to the offset in the microcontroller ADC measurement EVM. For accurate current reading, TI recommends using the IPROPI analog output on the header J4 to be measured externally. The voltage on this pin is dependent on the RIPROPI selection and the load current. The IPROPI current scaling factor for the driver device can be found in the data sheet.

Every control also has a help tip associated to quickly help the user while running the GUI.

4.3.3 Driver Control Page (HW Device Variant)

There are a few other minor differences between the SPI and HW device variant which are noted below:

- **WAKE** For the Hardware variant, selecting the jumpers while the device is asleep is necessary, and the default for the HW variant is "*=asleep*". If the user makes changes to the jumpers while the device is awake, then the device does not recognize those changes.
- **ENABLE DRIVER** Directly controls the DRV_{OFF} pin. When the bridge control is active the user cannot observe the passive diagnostics.
- **MODE** In Hardware variant, mode change must occur through jumpers while the GUI **WAKE** control is Asleep. See [Figure 2-8](#). Level 1 is PH/EN Mode, Level 2 is Independent Half-Bridge Mode, and Level 4 is PWM mode, as can be observed in the device data sheet. For Level 4, there is no jumper. The jumper settings for these Mode changes can be observed in [Section 2.4](#). For Independent Half-Bridge Mode, the user must correctly connect for either High-Side Load or Low-Side Load as can be observed in [Figure 4-6](#).
- **PASSIVE/ACTIVE DIAGNOSTICS** The active diagnostics controls do not exist on hardware devices. Only the passive diagnostics can be observed.



CAUTION

Driving an incorrectly connected load can result in permanent damage to the device, fire, or other damage.

When operating the EVM at the maximum device specifications and higher ambient temperature, external cooling fans can be required to minimize potential fire hazard, personal injury, or both.

4.3.4 Updating Firmware

Your EVM includes the ability to update the MCU firmware controlling the DRV824x-Q1, DRV826x-Q1, DRV814x-Q1, or DRV816x-Q1 device without any additional hardware. There is a pop-up every time the GUI Driver Control page is selected after an EVM connection is made and if a new update becomes available, then the update can be seen in [Figure 4-4](#).

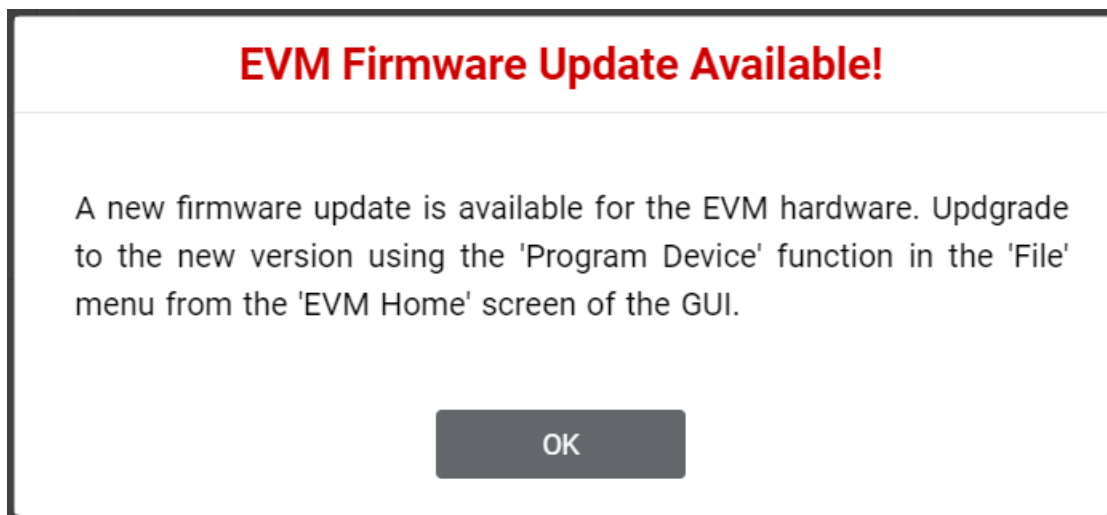

Figure 4-9. EVM Firmware Update Pop-up

The user can update the EVM to the latest firmware by simply going to File -> Program Device from either the EVM Home Page or the Driver Control page as shown in [Figure 4-10](#).



Figure 4-10. Update Firmware

5 Revision History

NOTE: Page numbers for previous revisions may differ from page numbers in the current version.

| Changes from Revision D (November 2023) to Revision E (November 2024) | Page |
|------------------------------------------------------------------------------|-------------|
|------------------------------------------------------------------------------|-------------|

| Changes from Revision C (October 2023) to Revision D (November 2023) | Page |
|-----------------------------------------------------------------------------|-------------|
| • Updated Figure 3-3 | 15 |
| • Updated Figure 3-4 | 16 |
| • Added GUI installer links..... | 16 |

| Changes from Revision B (May 2023) to Revision C (October 2023) | Page |
|------------------------------------------------------------------------|-------------|
| • Added <i>Device Signals Test Points</i> section..... | 10 |
| • Updated EVM images to reflect latest version of EVM..... | 14 |
| • Added note about bridge current accuracy..... | 20 |

| Changes from Revision A (July 2021) to Revision B (May 2023) | Page |
|---------------------------------------------------------------------|-------------|
| • Added Note about OUT1 and OUT2 silk screen labels..... | 5 |

| Changes from Revision * (April 2021) to Revision A (July 2021) | Page |
|-------------------------------------------------------------------------------|-------------|
| • Overview contents updated..... | 2 |
| • Updated LED Functions Description..... | 12 |
| • Updated images for new version..... | 15 |
| • Updated Connection Sequencing..... | 17 |
| • Updated EVM GUI operation description and Images for version 0.4.0..... | 17 |
| • Updated GUI Application images for version 0.4.0 | 20 |
| • Bullet Points for Passive/Active Diagnostics, Fault and Bridge Current..... | 20 |
| • Updated Image and Instructions in Updating Firmware Section..... | 24 |

STANDARD TERMS FOR EVALUATION MODULES

1. *Delivery:* TI delivers TI evaluation boards, kits, or modules, including any accompanying demonstration software, components, and/or documentation which may be provided together or separately (collectively, an "EVM" or "EVMs") to the User ("User") in accordance with the terms set forth herein. User's acceptance of the EVM is expressly subject to the following terms.
 - 1.1 EVMs are intended solely for product or software developers for use in a research and development setting to facilitate feasibility evaluation, experimentation, or scientific analysis of TI semiconductor products. EVMs have no direct function and are not finished products. EVMs shall not be directly or indirectly assembled as a part or subassembly in any finished product. For clarification, any software or software tools provided with the EVM ("Software") shall not be subject to the terms and conditions set forth herein but rather shall be subject to the applicable terms that accompany such Software
 - 1.2 EVMs are not intended for consumer or household use. EVMs may not be sold, sublicensed, leased, rented, loaned, assigned, or otherwise distributed for commercial purposes by Users, in whole or in part, or used in any finished product or production system.
2. *Limited Warranty and Related Remedies/Disclaimers:*
 - 2.1 These terms do not apply to Software. The warranty, if any, for Software is covered in the applicable Software License Agreement.
 - 2.2 TI warrants that the TI EVM will conform to TI's published specifications for ninety (90) days after the date TI delivers such EVM to User. Notwithstanding the foregoing, TI shall not be liable for a nonconforming EVM if (a) the nonconformity was caused by neglect, misuse or mistreatment by an entity other than TI, including improper installation or testing, or for any EVMs that have been altered or modified in any way by an entity other than TI, (b) the nonconformity resulted from User's design, specifications or instructions for such EVMs or improper system design, or (c) User has not paid on time. Testing and other quality control techniques are used to the extent TI deems necessary. TI does not test all parameters of each EVM. User's claims against TI under this Section 2 are void if User fails to notify TI of any apparent defects in the EVMs within ten (10) business days after delivery, or of any hidden defects with ten (10) business days after the defect has been detected.
 - 2.3 TI's sole liability shall be at its option to repair or replace EVMs that fail to conform to the warranty set forth above, or credit User's account for such EVM. TI's liability under this warranty shall be limited to EVMs that are returned during the warranty period to the address designated by TI and that are determined by TI not to conform to such warranty. If TI elects to repair or replace such EVM, TI shall have a reasonable time to repair such EVM or provide replacements. Repaired EVMs shall be warranted for the remainder of the original warranty period. Replaced EVMs shall be warranted for a new full ninety (90) day warranty period.

WARNING

Evaluation Kits are intended solely for use by technically qualified, professional electronics experts who are familiar with the dangers and application risks associated with handling electrical mechanical components, systems, and subsystems.

User shall operate the Evaluation Kit within TI's recommended guidelines and any applicable legal or environmental requirements as well as reasonable and customary safeguards. Failure to set up and/or operate the Evaluation Kit within TI's recommended guidelines may result in personal injury or death or property damage. Proper set up entails following TI's instructions for electrical ratings of interface circuits such as input, output and electrical loads.

NOTE:

EXPOSURE TO ELECTROSTATIC DISCHARGE (ESD) MAY CAUSE DEGRADATION OR FAILURE OF THE EVALUATION KIT; TI RECOMMENDS STORAGE OF THE EVALUATION KIT IN A PROTECTIVE ESD BAG.

3 Regulatory Notices:

3.1 United States

3.1.1 Notice applicable to EVMs not FCC-Approved:

FCC NOTICE: This kit is designed to allow product developers to evaluate electronic components, circuitry, or software associated with the kit to determine whether to incorporate such items in a finished product and software developers to write software applications for use with the end product. This kit is not a finished product and when assembled may not be resold or otherwise marketed unless all required FCC equipment authorizations are first obtained. Operation is subject to the condition that this product not cause harmful interference to licensed radio stations and that this product accept harmful interference. Unless the assembled kit is designed to operate under part 15, part 18 or part 95 of this chapter, the operator of the kit must operate under the authority of an FCC license holder or must secure an experimental authorization under part 5 of this chapter.

3.1.2 For EVMs annotated as FCC – FEDERAL COMMUNICATIONS COMMISSION Part 15 Compliant:

CAUTION

This device complies with part 15 of the FCC Rules. Operation is subject to the following two conditions: (1) This device may not cause harmful interference, and (2) this device must accept any interference received, including interference that may cause undesired operation.

Changes or modifications not expressly approved by the party responsible for compliance could void the user's authority to operate the equipment.

FCC Interference Statement for Class A EVM devices

NOTE: This equipment has been tested and found to comply with the limits for a Class A digital device, pursuant to part 15 of the FCC Rules. These limits are designed to provide reasonable protection against harmful interference when the equipment is operated in a commercial environment. This equipment generates, uses, and can radiate radio frequency energy and, if not installed and used in accordance with the instruction manual, may cause harmful interference to radio communications. Operation of this equipment in a residential area is likely to cause harmful interference in which case the user will be required to correct the interference at his own expense.

FCC Interference Statement for Class B EVM devices

NOTE: This equipment has been tested and found to comply with the limits for a Class B digital device, pursuant to part 15 of the FCC Rules. These limits are designed to provide reasonable protection against harmful interference in a residential installation. This equipment generates, uses and can radiate radio frequency energy and, if not installed and used in accordance with the instructions, may cause harmful interference to radio communications. However, there is no guarantee that interference will not occur in a particular installation. If this equipment does cause harmful interference to radio or television reception, which can be determined by turning the equipment off and on, the user is encouraged to try to correct the interference by one or more of the following measures:

- Reorient or relocate the receiving antenna.
- Increase the separation between the equipment and receiver.
- Connect the equipment into an outlet on a circuit different from that to which the receiver is connected.
- Consult the dealer or an experienced radio/TV technician for help.

3.2 Canada

3.2.1 For EVMs issued with an Industry Canada Certificate of Conformance to RSS-210 or RSS-247

Concerning EVMs Including Radio Transmitters:

This device complies with Industry Canada license-exempt RSSs. Operation is subject to the following two conditions:

(1) this device may not cause interference, and (2) this device must accept any interference, including interference that may cause undesired operation of the device.

Concernant les EVMs avec appareils radio:

Le présent appareil est conforme aux CNR d'Industrie Canada applicables aux appareils radio exempts de licence. L'exploitation est autorisée aux deux conditions suivantes: (1) l'appareil ne doit pas produire de brouillage, et (2) l'utilisateur de l'appareil doit accepter tout brouillage radioélectrique subi, même si le brouillage est susceptible d'en compromettre le fonctionnement.

Concerning EVMs Including Detachable Antennas:

Under Industry Canada regulations, this radio transmitter may only operate using an antenna of a type and maximum (or lesser) gain approved for the transmitter by Industry Canada. To reduce potential radio interference to other users, the antenna type and its gain should be so chosen that the equivalent isotropically radiated power (e.i.r.p.) is not more than that necessary for successful communication. This radio transmitter has been approved by Industry Canada to operate with the antenna types listed in the user guide with the maximum permissible gain and required antenna impedance for each antenna type indicated. Antenna types not included in this list, having a gain greater than the maximum gain indicated for that type, are strictly prohibited for use with this device.

Concernant les EVMs avec antennes détachables

Conformément à la réglementation d'Industrie Canada, le présent émetteur radio peut fonctionner avec une antenne d'un type et d'un gain maximal (ou inférieur) approuvé pour l'émetteur par Industrie Canada. Dans le but de réduire les risques de brouillage radioélectrique à l'intention des autres utilisateurs, il faut choisir le type d'antenne et son gain de sorte que la puissance isotrope rayonnée équivalente (p.i.r.e.) ne dépasse pas l'intensité nécessaire à l'établissement d'une communication satisfaisante. Le présent émetteur radio a été approuvé par Industrie Canada pour fonctionner avec les types d'antenne énumérés dans le manuel d'usage et ayant un gain admissible maximal et l'impédance requise pour chaque type d'antenne. Les types d'antenne non inclus dans cette liste, ou dont le gain est supérieur au gain maximal indiqué, sont strictement interdits pour l'exploitation de l'émetteur.

3.3 Japan

3.3.1 *Notice for EVMs delivered in Japan:* Please see http://www.tij.co.jp/lstds/ti_ja/general/eStore/notice_01.page 日本国内に輸入される評価用キット、ボードについては、次のところをご覧ください。

<https://www.ti.com/ja-jp/legal/notice-for-evaluation-kits-delivered-in-japan.html>

3.3.2 *Notice for Users of EVMs Considered "Radio Frequency Products" in Japan:* EVMs entering Japan may not be certified by TI as conforming to Technical Regulations of Radio Law of Japan.

If User uses EVMs in Japan, not certified to Technical Regulations of Radio Law of Japan, User is required to follow the instructions set forth by Radio Law of Japan, which includes, but is not limited to, the instructions below with respect to EVMs (which for the avoidance of doubt are stated strictly for convenience and should be verified by User):

1. Use EVMs in a shielded room or any other test facility as defined in the notification #173 issued by Ministry of Internal Affairs and Communications on March 28, 2006, based on Sub-section 1.1 of Article 6 of the Ministry's Rule for Enforcement of Radio Law of Japan,
2. Use EVMs only after User obtains the license of Test Radio Station as provided in Radio Law of Japan with respect to EVMs, or
3. Use of EVMs only after User obtains the Technical Regulations Conformity Certification as provided in Radio Law of Japan with respect to EVMs. Also, do not transfer EVMs, unless User gives the same notice above to the transferee. Please note that if User does not follow the instructions above, User will be subject to penalties of Radio Law of Japan.

【無線電波を送信する製品の開発キットをお使いになる際の注意事項】 開発キットの中には技術基準適合証明を受けていないものがあります。技術適合証明を受けていないものご使用に際しては、電波法遵守のため、以下のいずれかの措置を取っていただく必要がありますのでご注意ください。

1. 電波法施行規則第6条第1項第1号に基づく平成18年3月28日総務省告示第173号で定められた電波暗室等の試験設備でご使用いただく。
2. 実験局の免許を取得後ご使用いただく。
3. 技術基準適合証明を取得後ご使用いただく。

なお、本製品は、上記の「ご使用にあたっての注意」を譲渡先、移転先に通知しない限り、譲渡、移転できないものとします。

上記を遵守頂けない場合は、電波法の罰則が適用される可能性があることをご留意ください。日本テキサス・イ

ンスツルメンツ株式会社

東京都新宿区西新宿 6 丁目 2 4 番 1 号

西新宿三井ビル

3.3.3 *Notice for EVMs for Power Line Communication:* Please see http://www.tij.co.jp/lstds/ti_ja/general/eStore/notice_02.page

電力線搬送波通信についての開発キットをお使いになる際の注意事項については、次のところをご覧ください。 <https://www.ti.com/ja-jp/legal/notice-for-evaluation-kits-for-power-line-communication.html>

3.4 European Union

3.4.1 *For EVMs subject to EU Directive 2014/30/EU (Electromagnetic Compatibility Directive):*

This is a class A product intended for use in environments other than domestic environments that are connected to a low-voltage power-supply network that supplies buildings used for domestic purposes. In a domestic environment this product may cause radio interference in which case the user may be required to take adequate measures.

-
- 4 *EVM Use Restrictions and Warnings:*
 - 4.1 EVMS ARE NOT FOR USE IN FUNCTIONAL SAFETY AND/OR SAFETY CRITICAL EVALUATIONS, INCLUDING BUT NOT LIMITED TO EVALUATIONS OF LIFE SUPPORT APPLICATIONS.
 - 4.2 User must read and apply the user guide and other available documentation provided by TI regarding the EVM prior to handling or using the EVM, including without limitation any warning or restriction notices. The notices contain important safety information related to, for example, temperatures and voltages.
 - 4.3 *Safety-Related Warnings and Restrictions:*
 - 4.3.1 User shall operate the EVM within TI's recommended specifications and environmental considerations stated in the user guide, other available documentation provided by TI, and any other applicable requirements and employ reasonable and customary safeguards. Exceeding the specified performance ratings and specifications (including but not limited to input and output voltage, current, power, and environmental ranges) for the EVM may cause personal injury or death, or property damage. If there are questions concerning performance ratings and specifications, User should contact a TI field representative prior to connecting interface electronics including input power and intended loads. Any loads applied outside of the specified output range may also result in unintended and/or inaccurate operation and/or possible permanent damage to the EVM and/or interface electronics. Please consult the EVM user guide prior to connecting any load to the EVM output. If there is uncertainty as to the load specification, please contact a TI field representative. During normal operation, even with the inputs and outputs kept within the specified allowable ranges, some circuit components may have elevated case temperatures. These components include but are not limited to linear regulators, switching transistors, pass transistors, current sense resistors, and heat sinks, which can be identified using the information in the associated documentation. When working with the EVM, please be aware that the EVM may become very warm.
 - 4.3.2 EVMs are intended solely for use by technically qualified, professional electronics experts who are familiar with the dangers and application risks associated with handling electrical mechanical components, systems, and subsystems. User assumes all responsibility and liability for proper and safe handling and use of the EVM by User or its employees, affiliates, contractors or designees. User assumes all responsibility and liability to ensure that any interfaces (electronic and/or mechanical) between the EVM and any human body are designed with suitable isolation and means to safely limit accessible leakage currents to minimize the risk of electrical shock hazard. User assumes all responsibility and liability for any improper or unsafe handling or use of the EVM by User or its employees, affiliates, contractors or designees.
 - 4.4 User assumes all responsibility and liability to determine whether the EVM is subject to any applicable international, federal, state, or local laws and regulations related to User's handling and use of the EVM and, if applicable, User assumes all responsibility and liability for compliance in all respects with such laws and regulations. User assumes all responsibility and liability for proper disposal and recycling of the EVM consistent with all applicable international, federal, state, and local requirements.
 5. *Accuracy of Information:* To the extent TI provides information on the availability and function of EVMs, TI attempts to be as accurate as possible. However, TI does not warrant the accuracy of EVM descriptions, EVM availability or other information on its websites as accurate, complete, reliable, current, or error-free.
 6. *Disclaimers:*
 - 6.1 EXCEPT AS SET FORTH ABOVE, EVMS AND ANY MATERIALS PROVIDED WITH THE EVM (INCLUDING, BUT NOT LIMITED TO, REFERENCE DESIGNS AND THE DESIGN OF THE EVM ITSELF) ARE PROVIDED "AS IS" AND "WITH ALL FAULTS." TI DISCLAIMS ALL OTHER WARRANTIES, EXPRESS OR IMPLIED, REGARDING SUCH ITEMS, INCLUDING BUT NOT LIMITED TO ANY EPIDEMIC FAILURE WARRANTY OR IMPLIED WARRANTIES OF MERCHANTABILITY OR FITNESS FOR A PARTICULAR PURPOSE OR NON-INFRINGEMENT OF ANY THIRD PARTY PATENTS, COPYRIGHTS, TRADE SECRETS OR OTHER INTELLECTUAL PROPERTY RIGHTS.
 - 6.2 EXCEPT FOR THE LIMITED RIGHT TO USE THE EVM SET FORTH HEREIN, NOTHING IN THESE TERMS SHALL BE CONSTRUED AS GRANTING OR CONFERRING ANY RIGHTS BY LICENSE, PATENT, OR ANY OTHER INDUSTRIAL OR INTELLECTUAL PROPERTY RIGHT OF TI, ITS SUPPLIERS/LICENSORS OR ANY OTHER THIRD PARTY, TO USE THE EVM IN ANY FINISHED END-USER OR READY-TO-USE FINAL PRODUCT, OR FOR ANY INVENTION, DISCOVERY OR IMPROVEMENT, REGARDLESS OF WHEN MADE, CONCEIVED OR ACQUIRED.
 7. *USER'S INDEMNITY OBLIGATIONS AND REPRESENTATIONS.* USER WILL DEFEND, INDEMNIFY AND HOLD TI, ITS LICENSORS AND THEIR REPRESENTATIVES HARMLESS FROM AND AGAINST ANY AND ALL CLAIMS, DAMAGES, LOSSES, EXPENSES, COSTS AND LIABILITIES (COLLECTIVELY, "CLAIMS") ARISING OUT OF OR IN CONNECTION WITH ANY HANDLING OR USE OF THE EVM THAT IS NOT IN ACCORDANCE WITH THESE TERMS. THIS OBLIGATION SHALL APPLY WHETHER CLAIMS ARISE UNDER STATUTE, REGULATION, OR THE LAW OF TORT, CONTRACT OR ANY OTHER LEGAL THEORY, AND EVEN IF THE EVM FAILS TO PERFORM AS DESCRIBED OR EXPECTED.
-

8. *Limitations on Damages and Liability:*

8.1 *General Limitations.* IN NO EVENT SHALL TI BE LIABLE FOR ANY SPECIAL, COLLATERAL, INDIRECT, PUNITIVE, INCIDENTAL, CONSEQUENTIAL, OR EXEMPLARY DAMAGES IN CONNECTION WITH OR ARISING OUT OF THESE TERMS OR THE USE OF THE EVMS , REGARDLESS OF WHETHER TI HAS BEEN ADVISED OF THE POSSIBILITY OF SUCH DAMAGES. EXCLUDED DAMAGES INCLUDE, BUT ARE NOT LIMITED TO, COST OF REMOVAL OR REINSTALLATION, ANCILLARY COSTS TO THE PROCUREMENT OF SUBSTITUTE GOODS OR SERVICES, RETESTING, OUTSIDE COMPUTER TIME, LABOR COSTS, LOSS OF GOODWILL, LOSS OF PROFITS, LOSS OF SAVINGS, LOSS OF USE, LOSS OF DATA, OR BUSINESS INTERRUPTION. NO CLAIM, SUIT OR ACTION SHALL BE BROUGHT AGAINST TI MORE THAN TWELVE (12) MONTHS AFTER THE EVENT THAT GAVE RISE TO THE CAUSE OF ACTION HAS OCCURRED.

8.2 *Specific Limitations.* IN NO EVENT SHALL TI'S AGGREGATE LIABILITY FROM ANY USE OF AN EVM PROVIDED HEREUNDER, INCLUDING FROM ANY WARRANTY, INDEMNITY OR OTHER OBLIGATION ARISING OUT OF OR IN CONNECTION WITH THESE TERMS, , EXCEED THE TOTAL AMOUNT PAID TO TI BY USER FOR THE PARTICULAR EVM(S) AT ISSUE DURING THE PRIOR TWELVE (12) MONTHS WITH RESPECT TO WHICH LOSSES OR DAMAGES ARE CLAIMED. THE EXISTENCE OF MORE THAN ONE CLAIM SHALL NOT ENLARGE OR EXTEND THIS LIMIT.

9. *Return Policy.* Except as otherwise provided, TI does not offer any refunds, returns, or exchanges. Furthermore, no return of EVM(s) will be accepted if the package has been opened and no return of the EVM(s) will be accepted if they are damaged or otherwise not in a resalable condition. If User feels it has been incorrectly charged for the EVM(s) it ordered or that delivery violates the applicable order, User should contact TI. All refunds will be made in full within thirty (30) working days from the return of the components(s), excluding any postage or packaging costs.

10. *Governing Law:* These terms and conditions shall be governed by and interpreted in accordance with the laws of the State of Texas, without reference to conflict-of-laws principles. User agrees that non-exclusive jurisdiction for any dispute arising out of or relating to these terms and conditions lies within courts located in the State of Texas and consents to venue in Dallas County, Texas. Notwithstanding the foregoing, any judgment may be enforced in any United States or foreign court, and TI may seek injunctive relief in any United States or foreign court.

Mailing Address: Texas Instruments, Post Office Box 655303, Dallas, Texas 75265
Copyright © 2023, Texas Instruments Incorporated

IMPORTANT NOTICE AND DISCLAIMER

TI PROVIDES TECHNICAL AND RELIABILITY DATA (INCLUDING DATA SHEETS), DESIGN RESOURCES (INCLUDING REFERENCE DESIGNS), APPLICATION OR OTHER DESIGN ADVICE, WEB TOOLS, SAFETY INFORMATION, AND OTHER RESOURCES "AS IS" AND WITH ALL FAULTS, AND DISCLAIMS ALL WARRANTIES, EXPRESS AND IMPLIED, INCLUDING WITHOUT LIMITATION ANY IMPLIED WARRANTIES OF MERCHANTABILITY, FITNESS FOR A PARTICULAR PURPOSE OR NON-INFRINGEMENT OF THIRD PARTY INTELLECTUAL PROPERTY RIGHTS.

These resources are intended for skilled developers designing with TI products. You are solely responsible for (1) selecting the appropriate TI products for your application, (2) designing, validating and testing your application, and (3) ensuring your application meets applicable standards, and any other safety, security, regulatory or other requirements.

These resources are subject to change without notice. TI grants you permission to use these resources only for development of an application that uses the TI products described in the resource. Other reproduction and display of these resources is prohibited. No license is granted to any other TI intellectual property right or to any third party intellectual property right. TI disclaims responsibility for, and you will fully indemnify TI and its representatives against, any claims, damages, costs, losses, and liabilities arising out of your use of these resources.

TI's products are provided subject to [TI's Terms of Sale](#) or other applicable terms available either on [ti.com](https://www.ti.com) or provided in conjunction with such TI products. TI's provision of these resources does not expand or otherwise alter TI's applicable warranties or warranty disclaimers for TI products.

TI objects to and rejects any additional or different terms you may have proposed.

Mailing Address: Texas Instruments, Post Office Box 655303, Dallas, Texas 75265

Copyright © 2025, Texas Instruments Incorporated