

# SN74AHC132 Quadruple Positive-NAND Gates with Schmitt-Trigger Inputs

## 1 Features

- Operating range 2V to 5.5V  $V_{CC}$
- Operation from very slow input transitions
- Temperature-compensated threshold levels
- High noise immunity
- Same pinouts as [SNx4AHC00](#)
- Latch-up performance exceeds 250mA per JESD 17
- ESD protection exceeds JESD 22
  - 2000V human-body model
  - 1000V charged-device model

## 2 Applications

- [Electronic points of sale](#)
- [Telecom infrastructure](#)
- [Network switches](#)
- [Tests and measurements](#)

## 3 Description

The SN74AHC132 device is a quadruple positive-NAND gate designed for 2V to 5.5V  $V_{CC}$  operation. This device performs the Boolean function  $Y = \overline{A \times B}$  or  $Y = \overline{A} + \overline{B}$  in positive logic.

Schmitt-trigger inputs provide added noise immunity and support for slow input signal transitions.

### Package Information

PART NUMBER	PACKAGE <sup>(1)</sup>	PACKAGE SIZE <sup>(2)</sup>	BODY SIZE <sup>(3)</sup>
SN74AHC132	BQA (WQFN, 14)	3mm × 2.5mm	3mm × 2.5mm
	D (SOIC, 14)	8.65mm × 6mm	8.65mm × 3.9mm
	DB (SSOP, 14)	6.2mm × 7.8mm	6.2mm × 5.3mm
	DGV (TVSOP, 14)	3.6mm × 6.4mm	3.6mm × 4.4mm
	PW (TSSOP, 14)	5mm × 6.4mm	5mm × 4.4mm
	RGY (VQFN, 14)	3.5mm × 3.5mm	3.5mm × 3.5mm
	N (PDIP, 14)	19.3mm × 9.4mm	19.3mm × 6.35mm
NS (SOP, 14)	10.2mm × 7.8mm	5.3mm × 10.3mm	

- (1) For more information, see [Section 11](#).
- (2) The package size (length × width) is a nominal value and includes pins, where applicable
- (3) The body size (length × width) is a nominal value and does not include pins.

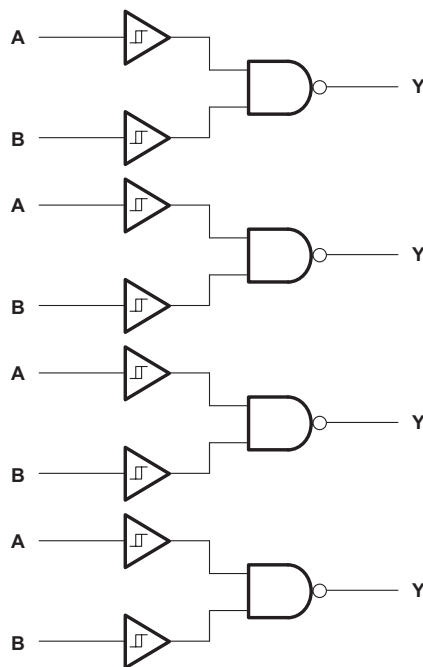

**Simplified Schematics**



## Table of Contents

<b>1 Features</b> .....	1	7.2 Functional Block Diagram.....	8
<b>2 Applications</b> .....	1	7.3 Feature Description.....	8
<b>3 Description</b> .....	1	7.4 Device Functional Modes.....	8
<b>4 Pin Configuration and Functions</b> .....	3	<b>8 Application and Implementation</b> .....	9
<b>5 Specifications</b> .....	4	8.1 Application Information.....	9
5.1 Absolute Maximum Ratings.....	4	8.2 Typical Application.....	9
5.2 Handling Ratings.....	4	8.3 Power Supply Recommendations.....	10
5.3 Recommended Operating Conditions.....	4	8.4 Layout.....	10
5.4 Thermal Information.....	5	<b>9 Device and Documentation Support</b> .....	11
5.5 Electrical Characteristics.....	5	9.1 Documentation Support (Analog).....	11
5.6 Switching Characteristics, $V_{CC} = 3.3\text{ V} \pm 0.3\text{ V}$ .....	6	9.2 Receiving Notification of Documentation Updates....	11
5.7 Switching Characteristics, $V_{CC} = 5\text{ V} \pm 0.5\text{ V}$ .....	6	9.3 Support Resources.....	11
5.8 Noise Characteristics.....	6	9.4 Trademarks.....	11
5.9 Operating Characteristics.....	6	9.5 Electrostatic Discharge Caution.....	11
5.10 Typical Characteristics.....	6	9.6 Glossary.....	11
<b>6 Parameter Measurement Information</b> .....	7	<b>10 Revision History</b> .....	11
<b>7 Detailed Description</b> .....	8	<b>11 Mechanical, Packaging, and Orderable Information</b> .....	12
7.1 Overview.....	8		

## 4 Pin Configuration and Functions

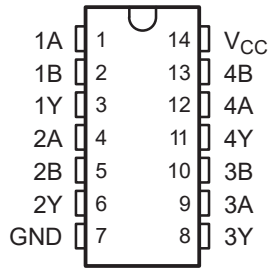

**Figure 4-1. SN74AHC132 D, DB, DGV, N, NS, or PW Package, 14-Pin (Top View)**

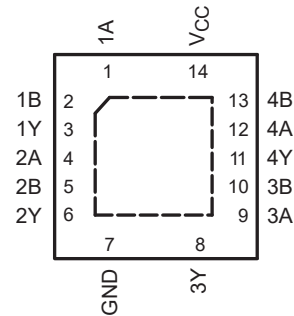

**Figure 4-2. SN74AHC132 RGY Package, 14-Pin VQFN (Top View)**

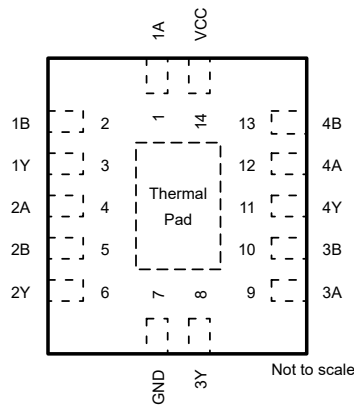

**Figure 4-3. SN74AHC132 BQA Package, 14-Pin WQFN (Top View)**

**Table 4-1. Pin Functions**

PIN		TYPE <sup>(1)</sup>	DESCRIPTION
NAME	NO.		
1A	1	I	1A Input
1B	2	I	1B Input
1Y	3	O	1Y Output
2A	4	I	2A Input
2B	5	I	2B Input
2Y	6	O	2Y Output
3Y	8	O	3Y Output
3A	9	I	3A Input
3B	10	I	3B Input
4Y	11	O	4Y Output
4A	12	I	4A Input
4B	13	I	4B Input
GND	7	—	Ground Pin
V <sub>CC</sub>	14	—	Power Pin
Thermal Pad <sup>(2)</sup>		—	The thermal pad can be connected to GND or left floating. Do not connect to any other signal or supply.

(1) I = input, O = output

(2) For BQA only.

## 5 Specifications

### 5.1 Absolute Maximum Ratings

over operating free-air temperature range (unless otherwise noted) <sup>(1)</sup>

		MIN	MAX	UNIT
V <sub>CC</sub>	Supply voltage range	-0.5	7	V
V <sub>I</sub>	Input voltage range <sup>(2)</sup>	-0.5	7	V
V <sub>O</sub>	Output voltage range <sup>(2)</sup>	-0.5	V <sub>CC</sub> + 0.5	V
I <sub>IK</sub>	Input clamp current	V <sub>I</sub> < 0		-20 mA
I <sub>OK</sub>	Output clamp current	V <sub>O</sub> < 0 or V <sub>O</sub> > V <sub>CC</sub>		±20 mA
I <sub>O</sub>	Continuous output current	V <sub>O</sub> = 0 to V <sub>CC</sub>		±25 mA
Continuous current through V <sub>CC</sub> or GND				±50 mA

- (1) Stresses beyond those listed under *Absolute Maximum Ratings* may cause permanent damage to the device. These are stress ratings only, and functional operation of the device at these or any other conditions beyond those indicated under *Recommended Operating Conditions* is not implied. Exposure to absolute-maximum-rated conditions for extended periods may affect device reliability.
- (2) The input and output voltage ratings may be exceeded if the input and output current ratings are observed.

### 5.2 Handling Ratings

		MIN	MAX	UNIT
T <sub>stg</sub>	Storage temperature range	-65	150	°C
V <sub>(ESD)</sub>	Electrostatic discharge	Human body model (HBM), per ANSI/ESDA/JEDEC JS-001, all pins <sup>(1)</sup>		V
		Charged device model (CDM), per JEDEC specification JESD22-C101, all pins <sup>(2)</sup>		
		0	2000	
		0	1000	

- (1) JEDEC document JEP155 states that 500-V HBM allows safe manufacturing with a standard ESD control process.
- (2) JEDEC document JEP157 states that 250-V CDM allows safe manufacturing with a standard ESD control process.

### 5.3 Recommended Operating Conditions

over operating free-air temperature range (unless otherwise noted)<sup>(1)</sup>

		SN74AHC132		UNIT
		MIN	MAX	
V <sub>CC</sub>	Supply voltage	2	5.5	V
V <sub>I</sub>	Input voltage	0	5.5	V
V <sub>O</sub>	Output voltage	0	V <sub>CC</sub>	V
I <sub>OH</sub>	High-level output current	V <sub>CC</sub> = 2 V		-50 μA
		V <sub>CC</sub> = 3.3 V ± 0.3 V		-4 mA
		V <sub>CC</sub> = 5 V ± 0.5 V		-8 mA
I <sub>OL</sub>	Low-level output current	V <sub>CC</sub> = 2 V		50 μA
		V <sub>CC</sub> = 3.3 V ± 0.3 V		4 mA
		V <sub>CC</sub> = 5 V ± 0.5 V		8 mA
T <sub>A</sub>	Operating free-air temperature	-40	125	°C

- (1) All unused inputs of the device must be held at V<sub>CC</sub> or GND for proper device operation. Refer to the TI application report, *Implications of Slow or Floating CMOS Inputs* (SCBA004).

## 5.4 Thermal Information

THERMAL METRIC <sup>(1)</sup>	SN74AHC132									UNIT
	BQA	D	DB	DR	N	NS	PW	RGY		
	14 PINS									
R <sub>θJA</sub>	Junction-to-ambient thermal resistance	88.3	124.6	107.1	90.6	57.4	90.7	147.7	57.5	°C/W
R <sub>θJC(top)</sub>	Junction-to-case (top) thermal resistance	90.9	79.7	59.6	50.9	44.9	48.3	77.4	57.5	
R <sub>θJB</sub>	Junction-to-board thermal resistance	56.8	81.2	54.4	44.8	37.2	49.4	90.9	33.6	
Ψ <sub>JT</sub>	Junction-to-top characterization parameter	9.9	39.3	20.5	14.7	30.1	14.6	27.2	3.4	
Ψ <sub>JB</sub>	Junction-to-board characterization parameter	56.7	80.8	53.8	44.5	37.1	49.1	90.2	33.7	
R <sub>θJC(bot)</sub>	Junction-to-case (bottom) thermal resistance	33.4	N/A	N/A	N/A	N/A	N/A	N/A	13.9	

(1) For more information about traditional and new thermal metrics, see the *IC Package Thermal Metrics* application report (SPRA953).

## 5.5 Electrical Characteristics

over recommended operating free-air temperature range (unless otherwise noted)

PARAMETER	TEST CONDITIONS	V <sub>CC</sub>	T <sub>A</sub> = 25°C			SN74AHC132		–40°C to 125°C SN74AHC132		UNIT
			MIN	TYP	MAX	MIN	MAX	MIN	MAX	
V <sub>T+</sub> Positive-going input threshold voltage		3 V	1.2		2.2	1.2	2.2	1.2	2.2	V
		4.5 V	1.75		3.15	1.75	3.15	1.75	3.15	
		5.5 V	2.15		3.85	2.15	3.85	2.15	3.85	
V <sub>T–</sub> Negative-going input threshold voltage		3 V	0.9		1.9	0.9	1.9	0.9	1.9	V
		4.5 V	1.35		2.75	1.35	2.75	1.35	2.75	
		5.5 V	1.65		3.35	1.65	3.35	1.65	3.35	
ΔV <sub>T</sub> Hysteresis (V <sub>T+</sub> – V <sub>T–</sub> )		3 V	0.3		1.2	0.3	1.2	0.3	1.2	V
		4.5 V	0.4		1.4	0.4	1.4	0.4	1.4	
		5.5 V	0.5		1.6	0.5	1.6	0.5	1.6	
V <sub>OH</sub>	I <sub>OH</sub> = –50 μA	2 V	1.9	2		1.9		1.9		V
		3 V	2.9	3		2.9		2.9		
		4.5 V	4.4	4.5		4.4		4.4		
	I <sub>OH</sub> = –4 mA	3 V	2.58			2.48		2.48		
	I <sub>OH</sub> = –8 mA	4.5 V	3.94			3.8		3.8		
V <sub>OL</sub>	I <sub>OL</sub> = 50 μA	2 V			0.1		0.1		0.1	V
		3 V			0.1		0.1		0.1	
		4.5 V			0.1		0.1		0.1	
	I <sub>OL</sub> = 4 mA	3 V			0.36		0.44		0.44	
	I <sub>OL</sub> = 8 mA	4.5 V			0.36		0.44		0.44	
I <sub>I</sub>	V <sub>I</sub> = 5.5 V or GND	0 V to 5.5 V			±0.1		±1		±1	μA
I <sub>CC</sub>	V <sub>I</sub> = V <sub>CC</sub> or GND I <sub>O</sub> = 0	5.5 V			2		20		20	μA
C <sub>i</sub>	V <sub>I</sub> = V <sub>CC</sub> or GND	5 V		1.9	10		10		10	pF

### 5.6 Switching Characteristics, $V_{CC} = 3.3\text{ V} \pm 0.3\text{ V}$

over recommended operating free-air temperature range (unless otherwise noted) (see (1))

PARAMETER	FROM (INPUT)	TO (OUTPUT)	LOAD CAPACITANCE	$T_A = 25^\circ\text{C}$			SN74AHC132		$T_A = -40^\circ\text{C}$ to $125^\circ\text{C}$ SN74AHC132		UNIT
				MIN	TYP	MAX	MIN	MAX	MIN	MAX	
$t_{PLH}$	A or B	Y	$C_L = 15\text{ pF}$		5.6 <sup>(1)</sup>	11.9 <sup>(1)</sup>	1	14	1	15	ns
$t_{PHL}$					5.6 <sup>(1)</sup>	11.9 <sup>(1)</sup>	1	14	1	15	
$t_{PLH}$	A or B	Y	$C_L = 50\text{ pF}$		7.6	15.4	1	17.5	1	19	ns
$t_{PHL}$					7.6	15.4	1	17.5	1	19	

(1) On products compliant to MIL-PRF-38535, this parameter is not production tested.

### 5.7 Switching Characteristics, $V_{CC} = 5\text{ V} \pm 0.5\text{ V}$

over recommended operating free-air temperature range (unless otherwise noted) (see (1))

PARAMETER	FROM (INPUT)	TO (OUTPUT)	LOAD CAPACITANCE	$T_A = 25^\circ\text{C}$			SN74AHC132		$T_A = -40^\circ\text{C}$ to $125^\circ\text{C}$ SN74AHC132		UNIT
				MIN	TYP	MAX	MIN	MAX	MIN	MAX	
$t_{PLH}$	A or B	Y	$C_L = 15\text{ pF}$		3.9 <sup>(1)</sup>	7.7 <sup>(1)</sup>	1	9	1	10	ns
$t_{PHL}$					3.9 <sup>(1)</sup>	7.7 <sup>(1)</sup>	1	9	1	10	
$t_{PLH}$	A or B	Y	$C_L = 50\text{ pF}$		5.3	9.7	1	11	1	12	ns
$t_{PHL}$					5.3	9.7	1	11	1	12	

(1) On products compliant to MIL-PRF-38535, this parameter is not production tested.

### 5.8 Noise Characteristics

$V_{CC} = 5\text{ V}$ ,  $C_L = 50\text{ pF}$ ,  $T_A = 25^\circ\text{C}$ <sup>(1)</sup>

PARAMETER		SN74AHC132			UNIT
		MIN	TYP	MAX	
$V_{OL(P)}$	Quiet output, maximum dynamic $V_{OL}$		0.45	0.8	V
$V_{OL(V)}$	Quiet output, minimum dynamic $V_{OL}$		-0.35	-0.8	V
$V_{OH(V)}$	Quiet output, minimum dynamic $V_{OH}$		4.8		V
$V_{IH(D)}$	High-level dynamic input voltage		3.5		V
$V_{IL(D)}$	Low-level dynamic input voltage			1.5	V

(1) Characteristics are for surface-mount packages only.

### 5.9 Operating Characteristics

$V_{CC} = 5\text{ V}$ ,  $T_A = 25^\circ\text{C}$

PARAMETER	TEST CONDITIONS	TYP	UNIT
$C_{pd}$	No load, $f = 1\text{ MHz}$	11	pF

### 5.10 Typical Characteristics

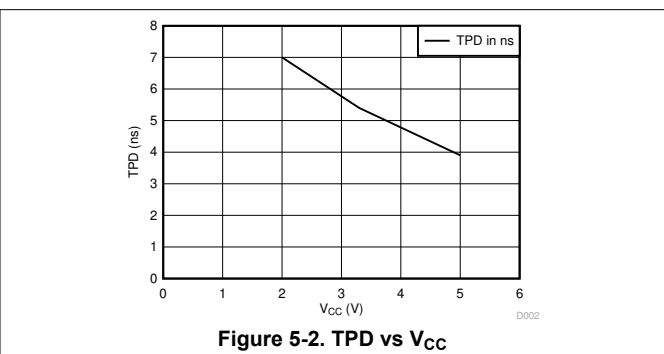
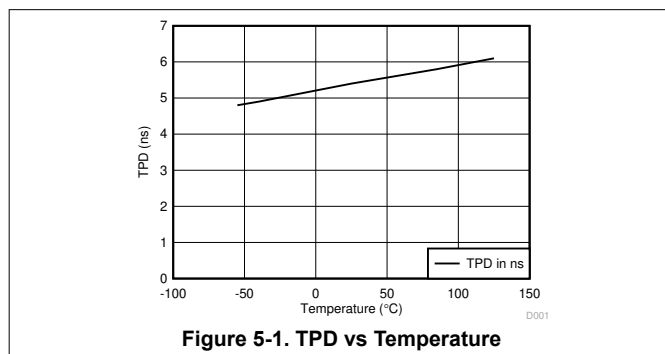

## 6 Parameter Measurement Information

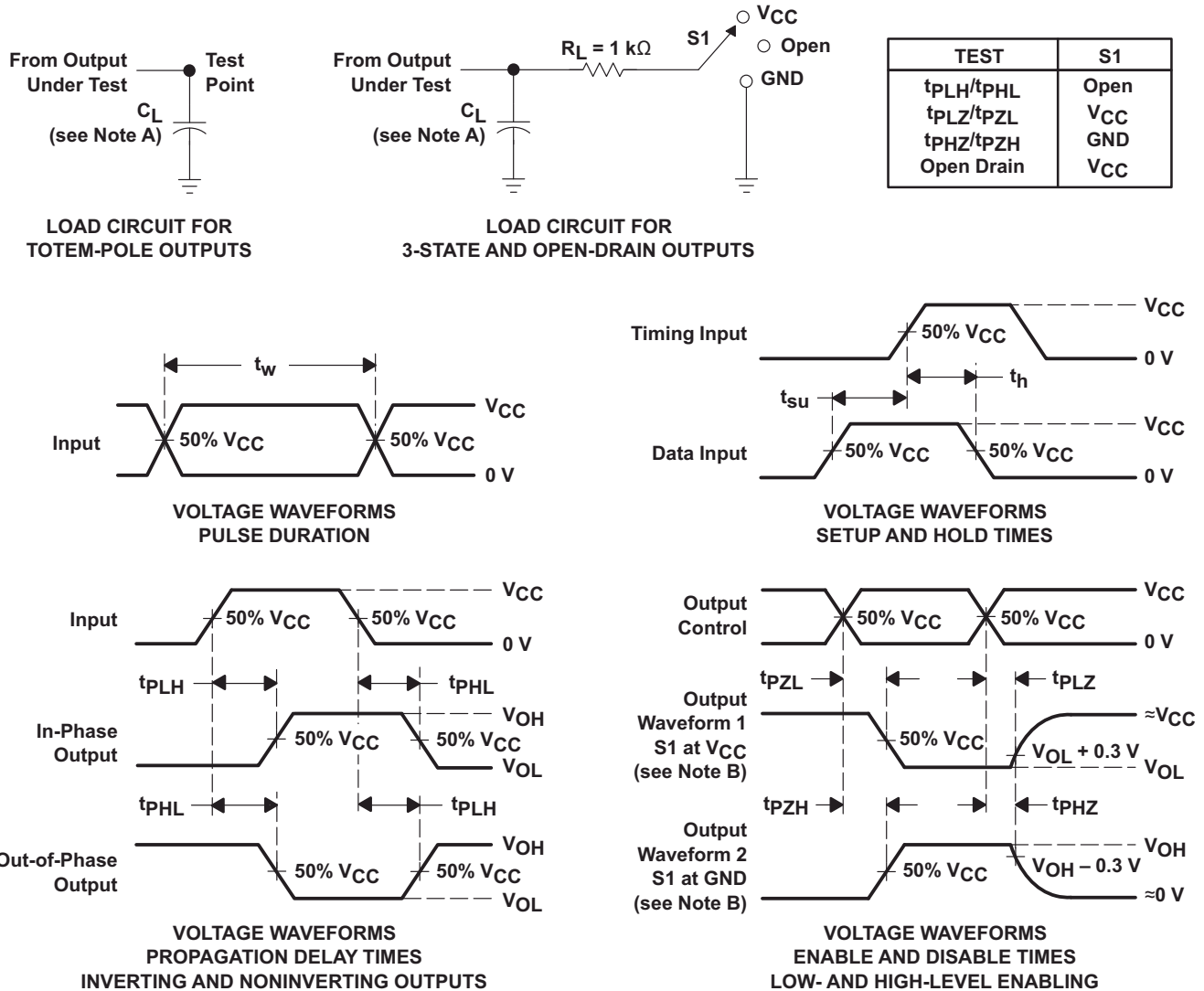

- NOTES:
- A.  $C_L$  includes probe and jig capacitance.
  - B. Waveform 1 is for an output with internal conditions such that the output is low except when disabled by the output control. Waveform 2 is for an output with internal conditions such that the output is high except when disabled by the output control.
  - C. All input pulses are supplied by generators having the following characteristics:  $PRR \leq 1$  MHz,  $Z_O = 50 \Omega$ ,  $t_r \leq 3$  ns,  $t_f \leq 3$  ns.
  - D. The outputs are measured one at a time with one input transition per measurement.
  - E. All parameters and waveforms are not applicable to all devices.

**Figure 6-1. Load Circuit and Voltage Waveforms**

## 7 Detailed Description

### 7.1 Overview

The SN74AHC132 is a quadruple 2-input positive-NAND gate with low drive that produces slow rise and fall times. This reduces ringing on the output signal.

Each circuit functions as a NAND gate, but because of the Schmitt action, it has different input threshold levels for positive- and negative-going signals.

These circuits are temperature compensated and can be triggered from the slowest of input ramps and still give clean, jitter-free output signals.

### 7.2 Functional Block Diagram

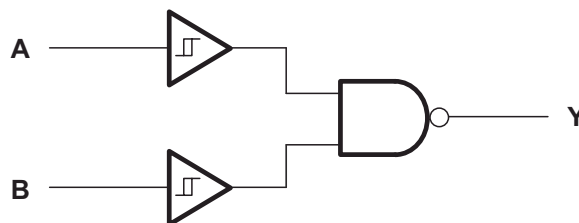

Figure 7-1. Logic Diagram, Each Gate (Positive Logic)

### 7.3 Feature Description

- Wide operating voltage range
  - Operates from 2 V to 5.5 V
- Allows down voltage translation
  - Inputs accept voltages to 5.5 V

### 7.4 Device Functional Modes

Table 7-1. Function Table  
(Each Gate)

INPUTS		OUTPUT Y
A	B	
H	H	L
L	X	H
X	L	H



## 8 Application and Implementation

### Note

Information in the following applications sections is not part of the TI component specification, and TI does not warrant its accuracy or completeness. TI's customers are responsible for determining suitability of components for their purposes, as well as validating and testing their design implementation to confirm system functionality.

### 8.1 Application Information

The SN74AHC132 is a low-drive CMOS device that can be used for a multitude of bus interface type applications where output ringing is a concern. The low drive and slow edge rates will minimize overshoot and undershoot on the outputs. The inputs can accept voltages to 5.5 V at any valid  $V_{CC}$ , thus making the device an excellent choice for down translation.

### 8.2 Typical Application

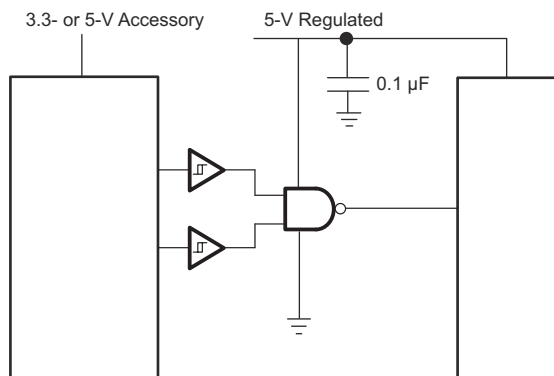

Figure 8-1. Typical Application Schematic

#### 8.2.1 Design Requirements

This device uses CMOS technology and has balanced output drive. Take care to avoid bus contention because it can drive currents that would exceed maximum limits. The high drive will also create fast edges into light loads, so routing and load conditions should be considered to prevent ringing.

#### 8.2.2 Detailed Design Procedure

1. Recommended input conditions:
  - For rise time and fall time specifications, see  $\Delta t/\Delta V$  in the [Recommended Operating Conditions](#) table.
  - For specified high and low levels, see  $V_{IH}$  and  $V_{IL}$  in the [Recommended Operating Conditions](#) table.
  - Inputs are overvoltage tolerant allowing them to go as high as 5.5 V at any valid  $V_{CC}$ .
2. Recommend output conditions:
  - Load currents should not exceed 25 mA per output and 50 mA total for the part.
  - Outputs should not be pulled above  $V_{CC}$ .

## 8.2.3 Application Curves

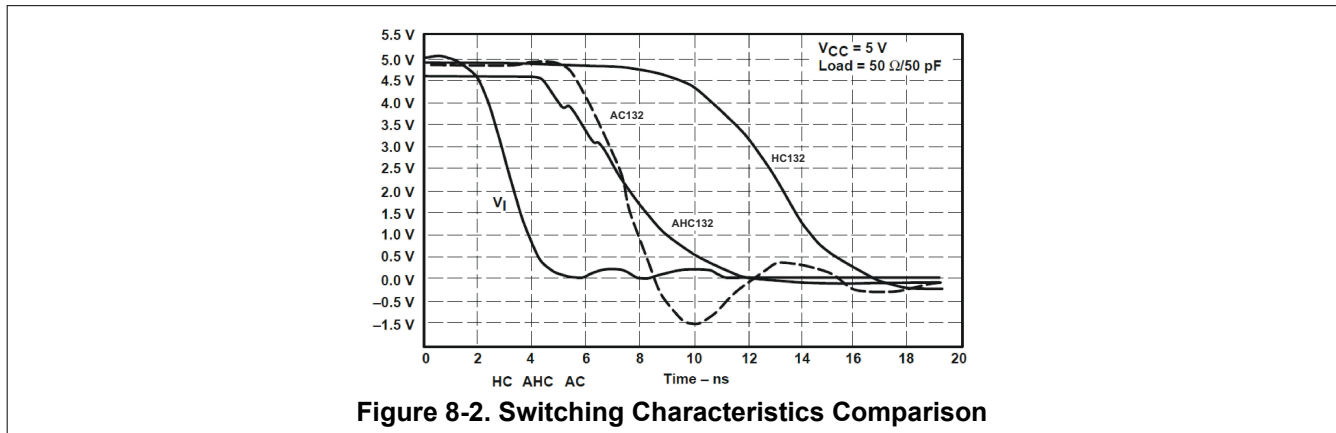

## 8.3 Power Supply Recommendations

The power supply can be any voltage between the MIN and MAX supply-voltage rating located in the [Recommended Operating Conditions](#) table.

Each  $V_{CC}$  pin should have a good bypass capacitor to prevent power disturbance. For devices with a single supply, 0.1  $\mu\text{F}$  is recommended. If there are multiple  $V_{CC}$  pins, then a 0.01  $\mu\text{F}$  or a 0.022  $\mu\text{F}$  is recommended for each power pin. It is acceptable to parallel multiple bypass capacitors to reject different frequencies of noise. A 0.1  $\mu\text{F}$  and a 1  $\mu\text{F}$  are commonly used in parallel. Install the bypass capacitor as close to the power pin as possible for best results.

## 8.4 Layout

### 8.4.1 Layout Guidelines

When using multiple bit logic devices, inputs should not float. In many cases, functions or parts of functions of digital logic devices are unused. Some examples are when only two inputs of a triple-input AND gate are used, or when only 3 of the 4-buffer gates are used. Such input pins should not be left unconnected because the undefined voltages at the outside connections result in undefined operational states.

Specified in the [Layout Examples](#) are rules that must be observed under all circumstances. All unused inputs of digital logic devices must be connected to a high or low bias to prevent them from floating. The logic level that should be applied to any particular unused input depends on the function of the device. Generally they will be tied to GND or  $V_{CC}$ , whichever makes more sense or is more convenient. It is acceptable to float outputs unless the part is a transceiver. If the transceiver has an output enable pin, then it will disable the outputs section of the part when asserted. This will not disable the input section of the I/Os so they also cannot float when disabled.

### 8.4.2 Layout Example

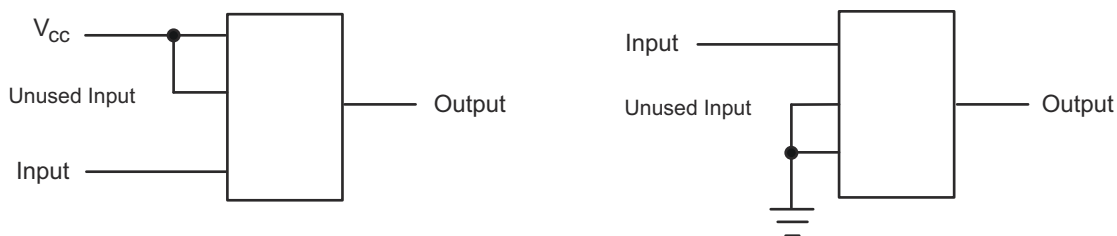

**Figure 8-3. Layout Diagram**

## 9 Device and Documentation Support

### 9.1 Documentation Support (Analog)

#### 9.1.1 Related Documentation

For related documentation, see the following:

- Texas Instruments, [CMOS Power Consumption and Cpd Calculation application note](#)
- Texas Instruments, [Designing With Logic application note](#)
- Texas Instruments, [Thermal Characteristics of Standard Linear and Logic \(SLL\) Packages and Devices application note](#)
- Texas Instruments, [Implications of Slow or Floating CMOS Inputs application note](#)

### 9.2 Receiving Notification of Documentation Updates

To receive notification of documentation updates, navigate to the device product folder on [ti.com](http://ti.com). Click on *Notifications* to register and receive a weekly digest of any product information that has changed. For change details, review the revision history included in any revised document.

### 9.3 Support Resources

[TI E2E™ support forums](#) are an engineer's go-to source for fast, verified answers and design help — straight from the experts. Search existing answers or ask your own question to get the quick design help you need.

Linked content is provided "AS IS" by the respective contributors. They do not constitute TI specifications and do not necessarily reflect TI's views; see TI's [Terms of Use](#).

### 9.4 Trademarks

TI E2E™ is a trademark of Texas Instruments.  
All trademarks are the property of their respective owners.

### 9.5 Electrostatic Discharge Caution



This integrated circuit can be damaged by ESD. Texas Instruments recommends that all integrated circuits be handled with appropriate precautions. Failure to observe proper handling and installation procedures can cause damage.

ESD damage can range from subtle performance degradation to complete device failure. Precision integrated circuits may be more susceptible to damage because very small parametric changes could cause the device not to meet its published specifications.

### 9.6 Glossary

[TI Glossary](#) This glossary lists and explains terms, acronyms, and definitions.

## 10 Revision History

<b>Changes from Revision J (October 2023) to Revision K (February 2024)</b>	<b>Page</b>
• Deleted machine model from <i>Features</i> section.....	1
• Updated thermal values for D package from R $\theta$ JA = 90.6 to 124.6, R $\theta$ JC(top) = 50.9 to 79.7, R $\theta$ JB = 44.8 to 81.2, $\Psi$ JT = 14.7 to 39.3, $\Psi$ JB = 44.5 to 80.8, R $\theta$ JC(bot) = N/A, all values in °C/W .....	5

<b>Changes from Revision I (August 2023) to Revision J (October 2023)</b>	<b>Page</b>
• Updated thermal values for PW package from R $\theta$ JA = 122.6 to 147.7, R $\theta$ JC(top) = 51.4 to 77.4, R $\theta$ JB = 64.4 to 90.9, $\Psi$ JT = 6.7 to 27.2, $\Psi$ JB = 63.8 to 90.2, all values in °C/W .....	5

## 11 Mechanical, Packaging, and Orderable Information

The following pages include mechanical, packaging, and orderable information. This information is the most current data available for the designated devices. This data is subject to change without notice and revision of this document. For browser-based versions of this data sheet, refer to the left-hand navigation.

**PACKAGING INFORMATION**

Orderable Device	Status (1)	Package Type	Package Drawing	Pins	Package Qty	Eco Plan (2)	Lead finish/ Ball material (6)	MSL Peak Temp (3)	Op Temp (°C)	Device Marking (4/5)	Samples
SN74AHC132BQAR	ACTIVE	WQFN	BQA	14	3000	RoHS & Green	NIPDAU	Level-1-260C-UNLIM	-40 to 125	AHC132	<a href="#">Samples</a>
SN74AHC132D	OBSOLETE	SOIC	D	14		TBD	Call TI	Call TI	-40 to 125	AHC132	
SN74AHC132DBR	ACTIVE	SSOP	DB	14	2000	RoHS & Green	NIPDAU	Level-1-260C-UNLIM	-40 to 125	HA132	<a href="#">Samples</a>
SN74AHC132DGVR	ACTIVE	TVSOP	DGV	14	2000	RoHS & Green	NIPDAU	Level-1-260C-UNLIM	-40 to 125	HA132	<a href="#">Samples</a>
SN74AHC132DR	ACTIVE	SOIC	D	14	2500	RoHS & Green	NIPDAU	Level-1-260C-UNLIM	-40 to 125	AHC132	<a href="#">Samples</a>
SN74AHC132N	ACTIVE	PDIP	N	14	25	RoHS & Green	NIPDAU	N / A for Pkg Type	-40 to 125	SN74AHC132N	<a href="#">Samples</a>
SN74AHC132NSR	ACTIVE	SO	NS	14	2000	RoHS & Green	NIPDAU	Level-1-260C-UNLIM	-40 to 125	AHC132	<a href="#">Samples</a>
SN74AHC132PW	OBSOLETE	TSSOP	PW	14		TBD	Call TI	Call TI	-40 to 125	HA132	
SN74AHC132PWR	ACTIVE	TSSOP	PW	14	2000	RoHS & Green	NIPDAU   SN	Level-1-260C-UNLIM	-40 to 125	HA132	<a href="#">Samples</a>
SN74AHC132RGR	ACTIVE	VQFN	RGY	14	3000	RoHS & Green	NIPDAU	Level-2-260C-1 YEAR	-40 to 125	HA132	<a href="#">Samples</a>

(1) The marketing status values are defined as follows:

**ACTIVE:** Product device recommended for new designs.

**LIFEBUY:** TI has announced that the device will be discontinued, and a lifetime-buy period is in effect.

**NRND:** Not recommended for new designs. Device is in production to support existing customers, but TI does not recommend using this part in a new design.

**PREVIEW:** Device has been announced but is not in production. Samples may or may not be available.

**OBSOLETE:** TI has discontinued the production of the device.

(2) **RoHS:** TI defines "RoHS" to mean semiconductor products that are compliant with the current EU RoHS requirements for all 10 RoHS substances, including the requirement that RoHS substance do not exceed 0.1% by weight in homogeneous materials. Where designed to be soldered at high temperatures, "RoHS" products are suitable for use in specified lead-free processes. TI may reference these types of products as "Pb-Free".

**RoHS Exempt:** TI defines "RoHS Exempt" to mean products that contain lead but are compliant with EU RoHS pursuant to a specific EU RoHS exemption.

**Green:** TI defines "Green" to mean the content of Chlorine (Cl) and Bromine (Br) based flame retardants meet JS709B low halogen requirements of <=1000ppm threshold. Antimony trioxide based flame retardants must also meet the <=1000ppm threshold requirement.

(3) MSL, Peak Temp. - The Moisture Sensitivity Level rating according to the JEDEC industry standard classifications, and peak solder temperature.

(4) There may be additional marking, which relates to the logo, the lot trace code information, or the environmental category on the device.

<sup>(5)</sup> Multiple Device Markings will be inside parentheses. Only one Device Marking contained in parentheses and separated by a "~" will appear on a device. If a line is indented then it is a continuation of the previous line and the two combined represent the entire Device Marking for that device.

<sup>(6)</sup> Lead finish/Ball material - Orderable Devices may have multiple material finish options. Finish options are separated by a vertical ruled line. Lead finish/Ball material values may wrap to two lines if the finish value exceeds the maximum column width.

**Important Information and Disclaimer:**The information provided on this page represents TI's knowledge and belief as of the date that it is provided. TI bases its knowledge and belief on information provided by third parties, and makes no representation or warranty as to the accuracy of such information. Efforts are underway to better integrate information from third parties. TI has taken and continues to take reasonable steps to provide representative and accurate information but may not have conducted destructive testing or chemical analysis on incoming materials and chemicals. TI and TI suppliers consider certain information to be proprietary, and thus CAS numbers and other limited information may not be available for release.

In no event shall TI's liability arising out of such information exceed the total purchase price of the TI part(s) at issue in this document sold by TI to Customer on an annual basis.

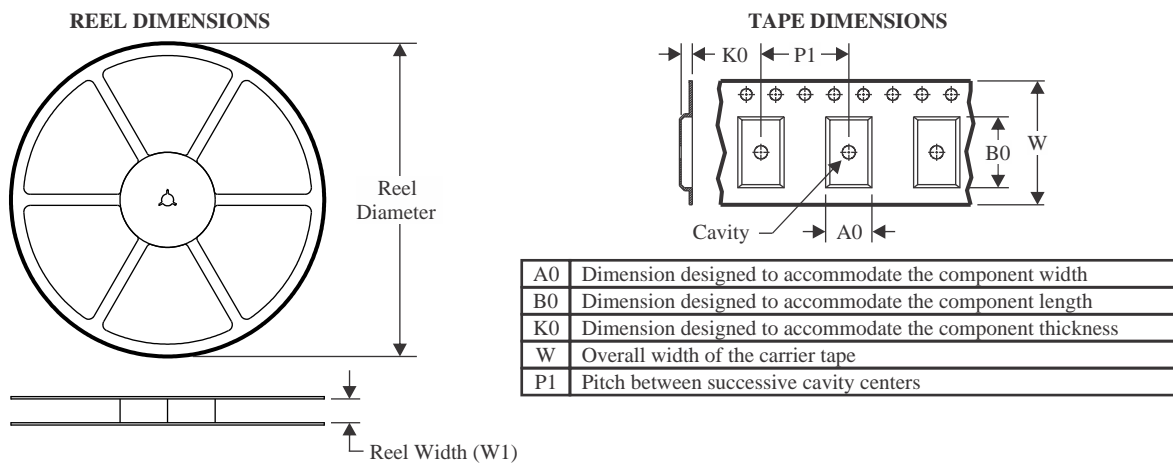
**TAPE AND REEL INFORMATION**

**QUADRANT ASSIGNMENTS FOR PIN 1 ORIENTATION IN TAPE**

\*All dimensions are nominal

Device	Package Type	Package Drawing	Pins	SPQ	Reel Diameter (mm)	Reel Width W1 (mm)	A0 (mm)	B0 (mm)	K0 (mm)	P1 (mm)	W (mm)	Pin1 Quadrant
SN74AHC132BQAR	WQFN	BQA	14	3000	180.0	12.4	2.8	3.3	1.1	4.0	12.0	Q1
SN74AHC132DBR	SSOP	DB	14	2000	330.0	16.4	8.35	6.6	2.4	12.0	16.0	Q1
SN74AHC132DGVR	TVSOP	DGV	14	2000	330.0	12.4	6.8	4.0	1.6	8.0	12.0	Q1
SN74AHC132DR	SOIC	D	14	2500	330.0	16.4	6.5	9.0	2.1	8.0	16.0	Q1
SN74AHC132NSR	SO	NS	14	2000	330.0	16.4	8.2	10.5	2.5	12.0	16.0	Q1
SN74AHC132PWR	TSSOP	PW	14	2000	330.0	12.4	6.9	5.6	1.6	8.0	12.0	Q1
SN74AHC132PWR	TSSOP	PW	14	2000	330.0	12.4	6.85	5.45	1.6	8.0	12.0	Q1
SN74AHC132PWR	TSSOP	PW	14	2000	330.0	12.4	6.9	5.6	1.6	8.0	12.0	Q1
SN74AHC132RGYR	VQFN	RGY	14	3000	330.0	12.4	3.75	3.75	1.15	8.0	12.0	Q1

## TAPE AND REEL BOX DIMENSIONS



\*All dimensions are nominal

Device	Package Type	Package Drawing	Pins	SPQ	Length (mm)	Width (mm)	Height (mm)
SN74AHC132BQAR	WQFN	BQA	14	3000	210.0	185.0	35.0
SN74AHC132DBR	SSOP	DB	14	2000	356.0	356.0	35.0
SN74AHC132DGVR	TVSOP	DGV	14	2000	356.0	356.0	35.0
SN74AHC132DR	SOIC	D	14	2500	356.0	356.0	35.0
SN74AHC132NSR	SO	NS	14	2000	356.0	356.0	35.0
SN74AHC132PWR	TSSOP	PW	14	2000	353.0	353.0	32.0
SN74AHC132PWR	TSSOP	PW	14	2000	366.0	364.0	50.0
SN74AHC132PWR	TSSOP	PW	14	2000	356.0	356.0	35.0
SN74AHC132RGYR	VQFN	RGY	14	3000	356.0	356.0	35.0



**TUBE**

\*All dimensions are nominal

Device	Package Name	Package Type	Pins	SPQ	L (mm)	W (mm)	T (μm)	B (mm)
SN74AHC132N	N	PDIP	14	25	506	13.97	11230	4.32
SN74AHC132N	N	PDIP	14	25	506	13.97	11230	4.32

## IMPORTANT NOTICE AND DISCLAIMER

TI PROVIDES TECHNICAL AND RELIABILITY DATA (INCLUDING DATA SHEETS), DESIGN RESOURCES (INCLUDING REFERENCE DESIGNS), APPLICATION OR OTHER DESIGN ADVICE, WEB TOOLS, SAFETY INFORMATION, AND OTHER RESOURCES "AS IS" AND WITH ALL FAULTS, AND DISCLAIMS ALL WARRANTIES, EXPRESS AND IMPLIED, INCLUDING WITHOUT LIMITATION ANY IMPLIED WARRANTIES OF MERCHANTABILITY, FITNESS FOR A PARTICULAR PURPOSE OR NON-INFRINGEMENT OF THIRD PARTY INTELLECTUAL PROPERTY RIGHTS.

These resources are intended for skilled developers designing with TI products. You are solely responsible for (1) selecting the appropriate TI products for your application, (2) designing, validating and testing your application, and (3) ensuring your application meets applicable standards, and any other safety, security, regulatory or other requirements.

These resources are subject to change without notice. TI grants you permission to use these resources only for development of an application that uses the TI products described in the resource. Other reproduction and display of these resources is prohibited. No license is granted to any other TI intellectual property right or to any third party intellectual property right. TI disclaims responsibility for, and you will fully indemnify TI and its representatives against, any claims, damages, costs, losses, and liabilities arising out of your use of these resources.

TI's products are provided subject to [TI's Terms of Sale](#) or other applicable terms available either on [ti.com](https://www.ti.com) or provided in conjunction with such TI products. TI's provision of these resources does not expand or otherwise alter TI's applicable warranties or warranty disclaimers for TI products.

TI objects to and rejects any additional or different terms you may have proposed.

Mailing Address: Texas Instruments, Post Office Box 655303, Dallas, Texas 75265  
Copyright © 2024, Texas Instruments Incorporated