

# **TVP5158, TVP5157, TVP5156**

## **Four-Channel NTSC/PAL Video Decoders**

**With Independent Scalers, Noise Reduction, Auto Contrast, and Flexible Output Formatter for Security and Other Multi-Channel Video Applications**

## **Data Manual**



PRODUCTION DATA information is current as of publication date. Products conform to specifications per the terms of the Texas Instruments standard warranty. Production processing does not necessarily include testing of all parameters.

Literature Number: SLES243G  
July 2009–Revised April 2013

## Contents

<b>1</b>	<b>Introduction</b>	<b>8</b>
1.1	Features	8
1.2	Applications	9
1.3	Description	9
1.4	Related Products	9
1.5	Trademarks	10
1.6	Document Conventions	10
1.7	Ordering Information	10
1.8	Functional Block Diagram	11
<b>2</b>	<b>Terminal Assignments</b>	<b>12</b>
2.1	Pinout	12
<b>3</b>	<b>Functional Description</b>	<b>15</b>
3.1	Analog Video Processing and A/D Converters	15
3.1.1	Analog Video Input	15
3.1.2	Analog Video Input Clamping	16
3.1.3	A/D Converter	16
3.2	Digital Video Processing	16
3.2.1	2x Decimation Filter	16
3.2.2	Automatic Gain Control	16
3.2.3	Composite Processor	16
3.2.3.1	Color Low-Pass Filter	17
3.2.3.2	Y/C Separation	18
3.2.4	Luminance Processing	19
3.3	AVID Cropping	20
3.4	Embedded Syncs	20
3.5	Scaler	21
3.6	Noise Reduction	21
3.7	Auto Contrast	21
3.8	Output Formatter	22
3.8.1	Non-Interleaved Mode	22
3.8.2	Pixel-Interleaved Mode	22
3.8.2.1	2-Ch Pixel-Interleaved Mode	23
3.8.2.2	4-Ch Pixel-Interleaved Mode	23
3.8.2.3	Metadata Insertion for Non-Interleave Mode and Pixel-Interleaved Mode	24
3.8.3	Line-Interleaved Mode Support (TVP5158 only)	25
3.8.3.1	2-Ch Line-Interleaved Mode	25
3.8.3.2	4-Ch Line-Interleaved Mode	26
3.8.3.3	8-Ch Line-Interleaved Mode	26
3.8.3.4	Hybrid Modes	28
3.8.3.5	Metadata Insertion for Line-Interleaved Mode	28
3.9	Audio Sub-System (TVP5157 and TVP5158 Only)	31
3.9.1	Features	31
3.9.2	Audio Sub-System Functional Diagram	32
3.9.3	Serial Audio Interface	33
3.9.4	Analog Audio Input Clamping	33
3.9.5	Audio Cascade Connection	34
3.10	I <sup>2</sup> C Host Interface	36
3.10.1	I <sup>2</sup> C Write Operation	37
3.10.2	I <sup>2</sup> C Read Operation	37
3.10.3	VBUS Access	39
3.11	Clock Circuits	40

3.12	Reset Mode .....	<a href="#">41</a>
<b>4</b>	<b>Internal Control Registers .....</b>	<b><a href="#">42</a></b>
4.1	Overview .....	<a href="#">42</a>
4.2	Register Definitions .....	<a href="#">45</a>
<b>5</b>	<b>Electrical Specifications .....</b>	<b><a href="#">90</a></b>
5.1	Absolute Maximum Ratings .....	<a href="#">90</a>
5.2	Recommended Operating Conditions .....	<a href="#">91</a>
5.3	Reference Clock Specifications .....	<a href="#">91</a>
5.4	Electrical Characteristics .....	<a href="#">92</a>
5.5	DC Electrical Characteristics .....	<a href="#">92</a>
5.6	Video A/D Converters Electrical Characteristics .....	<a href="#">93</a>
5.7	Audio A/D Converters Electrical Characteristics .....	<a href="#">93</a>
5.8	Video Output Clock and Data Timing .....	<a href="#">94</a>
5.8.1	Video Input Clock and Data Timing .....	<a href="#">94</a>
5.9	I <sup>2</sup> C Host Port Timing .....	<a href="#">95</a>
5.9.1	I <sup>2</sup> S Port Timing .....	<a href="#">96</a>
5.10	Miscellaneous Timings .....	<a href="#">96</a>
5.11	Power Dissipation Ratings .....	<a href="#">96</a>
<b>6</b>	<b>Application Information .....</b>	<b><a href="#">97</a></b>
6.1	4-Ch D1 Applications .....	<a href="#">97</a>
6.2	8-Ch CIF Applications .....	<a href="#">97</a>
6.3	16-Ch CIF Applications .....	<a href="#">98</a>
6.4	Application Circuit Examples .....	<a href="#">99</a>
6.5	Designing with PowerPAD™ Devices .....	<a href="#">100</a>
	<b>Revision History .....</b>	<b><a href="#">101</a></b>

## List of Figures

1-1	Functional Block Diagram .....	<a href="#">11</a>
3-1	Video Analog Processing and ADC Block Diagram .....	<a href="#">15</a>
3-2	Anti-Aliasing Filter Frequency Response .....	<a href="#">16</a>
3-3	Composite Processor Block Diagram.....	<a href="#">17</a>
3-4	Color Low-Pass Filter Frequency Response .....	<a href="#">18</a>
3-5	Color Low-Pass Filter with Filter Characteristics, NTSC/PAL ITU-R BT.601 Sampling.....	<a href="#">18</a>
3-6	Chroma Trap Filter Frequency Response, NTSC ITU-R BT.601 Sampling .....	<a href="#">19</a>
3-7	Chroma Trap Filter Frequency Response, PAL ITU-R BT.601 Sampling .....	<a href="#">19</a>
3-8	Luminance Edge-Enhancer Peaking Block Diagram .....	<a href="#">20</a>
3-9	Peaking Filter Response, NTSC/PAL ITU-R BT.601 Sampling .....	<a href="#">20</a>
3-10	2-Ch Pixel-Interleaved Mode Timing Diagram.....	<a href="#">23</a>
3-11	4-Ch Pixel-Interleaved Mode Timing Diagram.....	<a href="#">24</a>
3-12	Cascade Connection for 16-Ch CIF Recoding and Multi-Ch CIF Preview .....	<a href="#">27</a>
3-13	Cascade Connection for 16-Ch CIF Recoding and Multi-Ch Half-D1 Preview.....	<a href="#">28</a>
3-14	Cascade Connection for 16-Ch CIF Recoding and 2-Ch D1/Multi-Ch CIF Preview.....	<a href="#">28</a>
3-15	Start Code in 8-Bit BT.656 Interface .....	<a href="#">29</a>
3-16	Start Code in 16-Bit YCbCr 4:2:2 Interface .....	<a href="#">30</a>
3-17	Audio Sub-System Functional Diagram .....	<a href="#">33</a>
3-18	Serial Audio Interface Timing Diagram .....	<a href="#">33</a>
3-19	Audio Cascade Connection .....	<a href="#">34</a>
3-20	VBUS Access .....	<a href="#">39</a>
3-21	Clock and Crystal Connectivity .....	<a href="#">40</a>
3-22	Reset Timing .....	<a href="#">41</a>
5-1	Video Output Clock and Data Timing.....	<a href="#">94</a>
5-2	I <sup>2</sup> C Host Port Timing .....	<a href="#">95</a>
6-1	4-Ch D1 Application (Single BT.656 Interface).....	<a href="#">97</a>
6-2	4-Ch D1 Application (16-Bit YCbCr 4:2:2 Interface) .....	<a href="#">97</a>
6-3	8-Ch CIF Real Time Encoding and Multi-Ch D1 Preview Application.....	<a href="#">98</a>
6-4	8-Ch CIF Real Time Encoding and Multi-Ch D1 Preview Application.....	<a href="#">98</a>
6-5	Video Input Connectivity .....	<a href="#">100</a>
6-6	Audio Input Connectivity .....	<a href="#">100</a>

## List of Tables

1-1	Device Options .....	<a href="#">9</a>
2-1	Terminal Functions .....	<a href="#">13</a>
3-1	EAV and SAV Sequence .....	<a href="#">20</a>
3-2	Standard Video Resolutions .....	<a href="#">21</a>
3-3	Video Resolutions Converted by the Scaler .....	<a href="#">21</a>
3-4	Summary of Line Frequencies, Data Rates and Pixel Counts for Different Standards .....	<a href="#">22</a>
3-5	Output Ports Configuration for Non-Interleaved Mode .....	<a href="#">22</a>
3-6	Output Ports Configuration for Pixel-Interleaved Mode .....	<a href="#">23</a>
3-7	VDET Statuses Insertion in SAV/EAV Codes.....	<a href="#">24</a>
3-8	Channel ID Insertion in Horizontal Blanking Code.....	<a href="#">24</a>
3-9	Channel ID Insertion in SAV/EAV Code Sequence.....	<a href="#">24</a>
3-10	Output Ports Configuration for Line-Interleaved Mode .....	<a href="#">25</a>
3-11	Default Super-Frame Format and Timing .....	<a href="#">29</a>
3-12	Bit Assignment of 4-Byte Start Code for Active Video Line.....	<a href="#">30</a>
3-13	Bit Field Definition of 4-Byte Start Code for Active Video Line .....	<a href="#">30</a>
3-14	Bit Assignment of 4-Byte Start Code for the Dummy Line .....	<a href="#">31</a>
3-15	Serial Audio Output Channel Assignment.....	<a href="#">35</a>
3-16	I <sup>2</sup> C Terminal Description .....	<a href="#">36</a>
3-17	I <sup>2</sup> C Host Interface Device Addresses .....	<a href="#">36</a>
3-18	Reset Mode .....	<a href="#">41</a>
3-19	Reset Sequence .....	<a href="#">41</a>
4-1	Registers Summary .....	<a href="#">42</a>
4-2	Status 1 .....	<a href="#">45</a>
4-3	Status 2 .....	<a href="#">46</a>
4-4	Color Subcarrier Phase Status .....	<a href="#">46</a>
4-5	ROM Version .....	<a href="#">46</a>
4-6	RAM Version MSB .....	<a href="#">47</a>
4-7	RAM Version LSB .....	<a href="#">47</a>
4-8	Chip ID MSB .....	<a href="#">47</a>
4-9	Chip ID LSB .....	<a href="#">47</a>
4-10	Video Standard Status .....	<a href="#">48</a>
4-11	Video Standard Select .....	<a href="#">48</a>
4-12	CVBS Autoswitch Mask .....	<a href="#">49</a>
4-13	Auto Contrast Mode .....	<a href="#">49</a>
4-14	Luminance Brightness .....	<a href="#">49</a>
4-15	Luminance Contrast .....	<a href="#">50</a>
4-16	Brightness and Contrast Range Extender .....	<a href="#">50</a>
4-17	Chrominance Saturation .....	<a href="#">50</a>
4-18	Chrominance Hue .....	<a href="#">51</a>
4-19	Color Killer .....	<a href="#">51</a>
4-20	Luminance Processing Control 1 .....	<a href="#">52</a>
4-21	Luminance Processing Control 2 .....	<a href="#">52</a>
4-22	Power Control .....	<a href="#">53</a>
4-23	Chrominance Processing Control 1 .....	<a href="#">54</a>
4-24	Chrominance Processing Control 2 .....	<a href="#">54</a>
4-25	AGC Gain Status .....	<a href="#">55</a>
4-26	Back-End AGC Status .....	<a href="#">55</a>

4-27	Status Request .....	<a href="#">55</a>
4-28	AFE Gain Control .....	<a href="#">55</a>
4-29	Luma ALC Freeze Upper Threshold .....	<a href="#">56</a>
4-30	Chroma ALC Freeze Upper Threshold .....	<a href="#">56</a>
4-31	AGC Increment Speed .....	<a href="#">56</a>
4-32	AGC Increment Delay .....	<a href="#">56</a>
4-33	AGC Decrement Speed .....	<a href="#">57</a>
4-34	AGC Decrement Delay .....	<a href="#">57</a>
4-35	AGC White Peak Processing .....	<a href="#">58</a>
4-36	Back-End AGC Control .....	<a href="#">59</a>
4-37	AFE Fine Gain .....	<a href="#">59</a>
4-38	AVID Start Pixel .....	<a href="#">60</a>
4-39	AVID Pixel Width .....	<a href="#">60</a>
4-40	Noise Reduction Max Noise .....	<a href="#">60</a>
4-41	Noise Reduction Control .....	<a href="#">61</a>
4-42	Noise Reduction Noise Filter Beta .....	<a href="#">61</a>
4-43	Operation Mode Control .....	<a href="#">62</a>
4-44	Color PLL Speed Control .....	<a href="#">62</a>
4-45	Sync Height Low Threshold .....	<a href="#">63</a>
4-46	Sync Height High Threshold .....	<a href="#">63</a>
4-47	Clear Lost Lock Detect .....	<a href="#">63</a>
4-48	VSYNC Filter Shift .....	<a href="#">63</a>
4-49	656 Version/F-bit Control .....	<a href="#">64</a>
4-50	F-Bit and V-Bit Decode Control .....	<a href="#">65</a>
4-51	F-Bit and V-Bit Control .....	<a href="#">66</a>
4-52	Output Timing Delay .....	<a href="#">66</a>
4-53	Auto Contrast User Table Index .....	<a href="#">67</a>
4-54	Blue Screen Y Control .....	<a href="#">67</a>
4-55	Blue Screen Cb Control .....	<a href="#">67</a>
4-56	Blue Screen Cr Control .....	<a href="#">68</a>
4-57	Blue Screen LSB Control .....	<a href="#">68</a>
4-58	Noise Measurement .....	<a href="#">68</a>
4-59	Weak Signal High Threshold .....	<a href="#">68</a>
4-60	Weak Signal Low Threshold .....	<a href="#">68</a>
4-61	Noise Reduction Y/U/V T0 .....	<a href="#">69</a>
4-62	Vertical Line Count Status .....	<a href="#">69</a>
4-63	Output Formatter Control 1 .....	<a href="#">69</a>
4-64	Output Formatter Control 2 .....	<a href="#">70</a>
4-65	Interrupt Control .....	<a href="#">70</a>
4-66	Embedded Sync Offset Control 1 .....	<a href="#">70</a>
4-67	Embedded Sync Offset Control 2 .....	<a href="#">71</a>
4-68	AVD Output Control 1 .....	<a href="#">72</a>
4-69	AVD Output Control 2 .....	<a href="#">73</a>
4-70	OFM Mode Control .....	<a href="#">74</a>
4-71	OFM Channel Select 1 .....	<a href="#">75</a>
4-72	OFM Channel Select 2 .....	<a href="#">76</a>
4-73	OFM Channel Select 3 .....	<a href="#">76</a>
4-74	OFM Super-Frame Size .....	<a href="#">77</a>

4-75	OFM EAV2SAV Duration .....	<a href="#">77</a>
4-76	Misc OFM Control .....	<a href="#">78</a>
4-77	Audio Sample Rate Control .....	<a href="#">78</a>
4-78	Analog Audio Gain Control 1 .....	<a href="#">79</a>
4-79	Analog Audio Gain Control 2 .....	<a href="#">80</a>
4-80	Audio Mode Control .....	<a href="#">81</a>
4-81	Audio Mixer Select .....	<a href="#">82</a>
4-82	Audio Mute Control .....	<a href="#">83</a>
4-83	Analog Mixing Ratio Control 1 .....	<a href="#">83</a>
4-84	Analog Mixing Ratio Control 2 .....	<a href="#">84</a>
4-85	Audio Cascade Mode Control .....	<a href="#">84</a>
4-86	Super-Frame EAV2SAV Duration Status .....	<a href="#">84</a>
4-87	Super-Frame SAV2EAV Duration Status .....	<a href="#">85</a>
4-88	VBUS Data Access With No VBUS Address Increment .....	<a href="#">85</a>
4-89	VBUS Data Access With VBUS Address Increment .....	<a href="#">85</a>
4-90	VBUS Address Access .....	<a href="#">85</a>
4-91	Interrupt Status .....	<a href="#">86</a>
4-92	Interrupt Mask .....	<a href="#">87</a>
4-93	Interrupt Clear .....	<a href="#">88</a>
4-94	Decoder Write Enable .....	<a href="#">88</a>
4-95	Decoder Read Enable .....	<a href="#">89</a>

## Four-Channel NTSC/PAL Video Decoders

Check for Samples: [TVP5158](#), [TVP5157](#), [TVP5156](#)

### 1 Introduction

#### 1.1 Features

- **Common Device Features (TVP5158, TVP5157, and TVP5156)**
  - Four separate video decoder channels having the following features for each channel
    - Accepts NTSC (J, M, 4.43) and PAL (B, D, G, H, I, M, N, Nc, 60) video data
    - Composite video inputs, pseudo-differential video inputs to improved noise immunity
    - High-speed 10-bit ADC
    - Fully differential CMOS analog preprocessing channels with clamping
    - Integrated anti-aliasing filter
    - 2D 5-line (5H) adaptive comb filter
    - Noise reduction and auto contrast
    - Robust automatic video standard detection (NTSC/PAL) and switching
    - Programmable hue, saturation, sharpness, brightness, and contrast
    - Luma-peaking processing
    - Patented architecture for locking to weak, noisy, or unstable signals
  - Four independent scalers support horizontal and/or vertical 2:1 downscaling
  - Channel multiplexing capabilities with metadata insertion
    - Pixel-interleaved mode supports up to four-channel D1 multiplexed 8-bit output at 108 MHz
    - Supports concurrent NTSC and PAL inputs
  - Support crystal interface with on-chip oscillator and single clock input mode
  - Single 27-MHz clock input or crystal for all standards and all channels
  - Internal phase-locked loop (PLL) for line-locked clock (separate for each channel) and sampling
  - Standard programmable video output format
    - ITU-R BT.656, 8-bit 4:2:2 with embedded syncs
    - YCbCr 16-bit 4:2:2 with embedded syncs
  - Macrovision™ copy protection detection
  - 3.3-V compatible I/O
  - 128-pin TQFP package
  - Available in commercial (0°C to 70°C) temperature range
- **Additional TVP5158 and TVP5157 Specific Features**
  - Integrated four-channel audio ADC with audio sample rate of 8 kHz or 16 kHz
  - Support Master and Slave mode I<sup>2</sup>S Output
  - Support audio cascade connection
- **Additional TVP5158 Specific Features**
  - Enhanced channel multiplexing capability – Line-interleaved mode
  - Four-channel D1 multiplexed output at 8 bit at 108 MHz
  - Video cascade connection for 8-Ch CIF, 8-Ch Half-D1, and 8-Ch CIF + 1-Ch D1 outputs
  - Also available in Industrial (-40°C to 85°C) temperature range
- **Qualified for Automotive Applications (AEC-Q100 Rev G – TVP5158IPNPQ1, TVP5158IPNPRQ1)**



Please be aware that an important notice concerning availability, standard warranty, and use in critical applications of Texas Instruments semiconductor products and disclaimers thereto appears at the end of this data sheet.

DaVinci is a trademark of Texas Instruments.

Macrovision is a trademark of Macrovision Corporation.

All other trademarks are the property of their respective owners.



## 1.2 Applications

- Security and surveillance digital video recorders or servers and PCI products
- Automotive infotainment video hub
- Large format video wall displays
- Game systems

## 1.3 Description

The TVP5158, TVP5157, and TVP5156 devices are 4-channel high-quality NTSC/PAL video decoders that digitize and decode all popular base-band analog video formats into digital video output. Each channel of this decoder includes 10-bit 27-MSPS A/D converter (ADC). Preceding each ADC in the device, the corresponding analog channel contains an analog circuit that clamps the input to a reference voltage and applies the gain.

Composite input signal is sampled at 2x the ITU-R BT.601 clock frequency, line-locked alignment, and is then decimated to the 1x pixel rate. CVBS decoding uses five-line adaptive comb filtering for both the luma and chroma data paths to reduce both cross-luma and cross-chroma artifacts. A chroma trap filter is also available. On CVBS inputs, the user can control video characteristics such as contrast, brightness, saturation, and hue via an I<sup>2</sup>C host port interface. Furthermore, luma peaking (sharpness) with programmable gain is included.

All four channels are independently controllable. These decoders share a single clock input for all channels and for all supported standards.

TVP5158 provides a glueless audio and video interface to TI DaVinci™ video processors. Video output ports support 8-bit ITU-R BT.656 and 16-bit 4:2:2 YCbCr with embedded synchronization. TVP5158 supports multiplexed pixel-interleaved and line-interleaved mode video outputs with metadata insertion. TVP5158 and TVP5157 integrate 4-Ch audio ADCs to reduce the BOM cost for surveillance market. Multiple TVP5158 devices can be cascade connected to support up to 8-Ch Video or 16-Ch audio processing.

Noise reduction and auto contrast functions improve the video quality under low light condition which is very critical for surveillance products.

The TVP5158, TVP5157, and TVP5156 can be programmed by using a single I<sup>2</sup>C serial interface. I<sup>2</sup>C commands can be sent to one or more decoder cores simultaneously, reducing the amount of I<sup>2</sup>C activity necessary to configure each core. This is especially useful for fast downloading modified firmware to the decoder cores.

TVP5158, TVP5157, and TVP5156 use 1.1-V, 1.8-V, and 3.3-V power supplies for the analog/digital core and I/O. These devices are available in a 128-pin TQFP package.

**Table 1-1. Device Options**

Device Name	4-Ch Audio ADC	Line-Interleaved Modes
TVP5156	No	No
TVP5157	Yes	No
TVP5158	Yes	Yes

## 1.4 Related Products

- TVP5154A
- TVP5150AM1
- TVP5146M2
- TVP5147M1

## 1.5 Trademarks

DaVinci, PowerPAD are trademarks of Texas Instruments.

Macrovision is a trademark of Macrovision Corporation.

Other trademarks are the property of their respective owners.

## 1.6 Document Conventions

Throughout this data manual, several conventions are used to convey information. These conventions are as follows:

- To identify a binary number or field, a lower case b follows the numbers. For example: 000b is a 3-bit binary field.
- To identify a hexadecimal number or field, a lower case h follows the numbers. For example: 8AFh is a 12-bit hexadecimal field.
- All other numbers that appear in this document that do not have either a b or h following the number are assumed to be decimal format.
- If the signal or terminal name has a bar above the name (for example, RESETB), then this indicates the logical NOT function. When asserted, this signal is a logic low, 0, or 0b.
- RSVD indicates that the referenced item is reserved.

## 1.7 Ordering Information

T <sub>A</sub>	PACKAGED DEVICES <sup>(1) (2)</sup> TQFP 128-Pin PowerPAD™ Package	PACKAGE OPTION
0°C to 70°C	TVP5156PNP	Tray
	TVP5156PNPR	Tape and reel
	TVP5157PNP	Tray
	TVP5157PNPR	Tape and reel
	TVP5158PNP	Tray
	TVP5158PNPR	Tape and reel
-40°C to 85°C	TVP5158IPNP	Tray
	TVP5158IPNPR	Tape and reel
	TVP5158IPNPQ1 <sup>(3)</sup>	Tray
	TVP5158IPNPRQ1 <sup>(3)</sup>	Tape and reel

(1) For the most current package and ordering information, see the Package Option Addendum at the end of this document, or see the TI web site at [www.ti.com](http://www.ti.com).

(2) Package drawings, thermal data, and symbolization are available at [www.ti.com/packaging](http://www.ti.com/packaging).

(3) AEC-Q100 Rev G certified

### 1.8 Functional Block Diagram

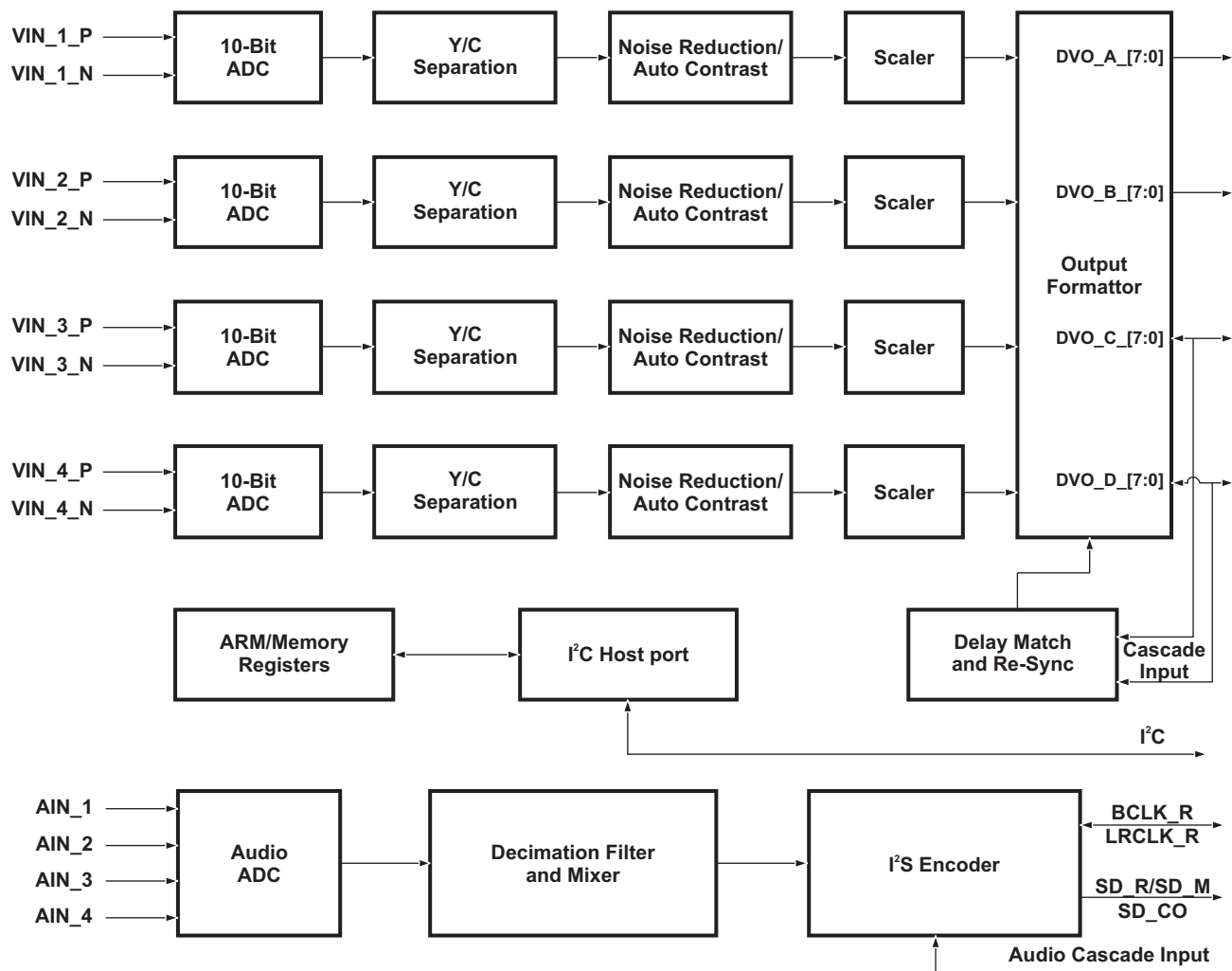
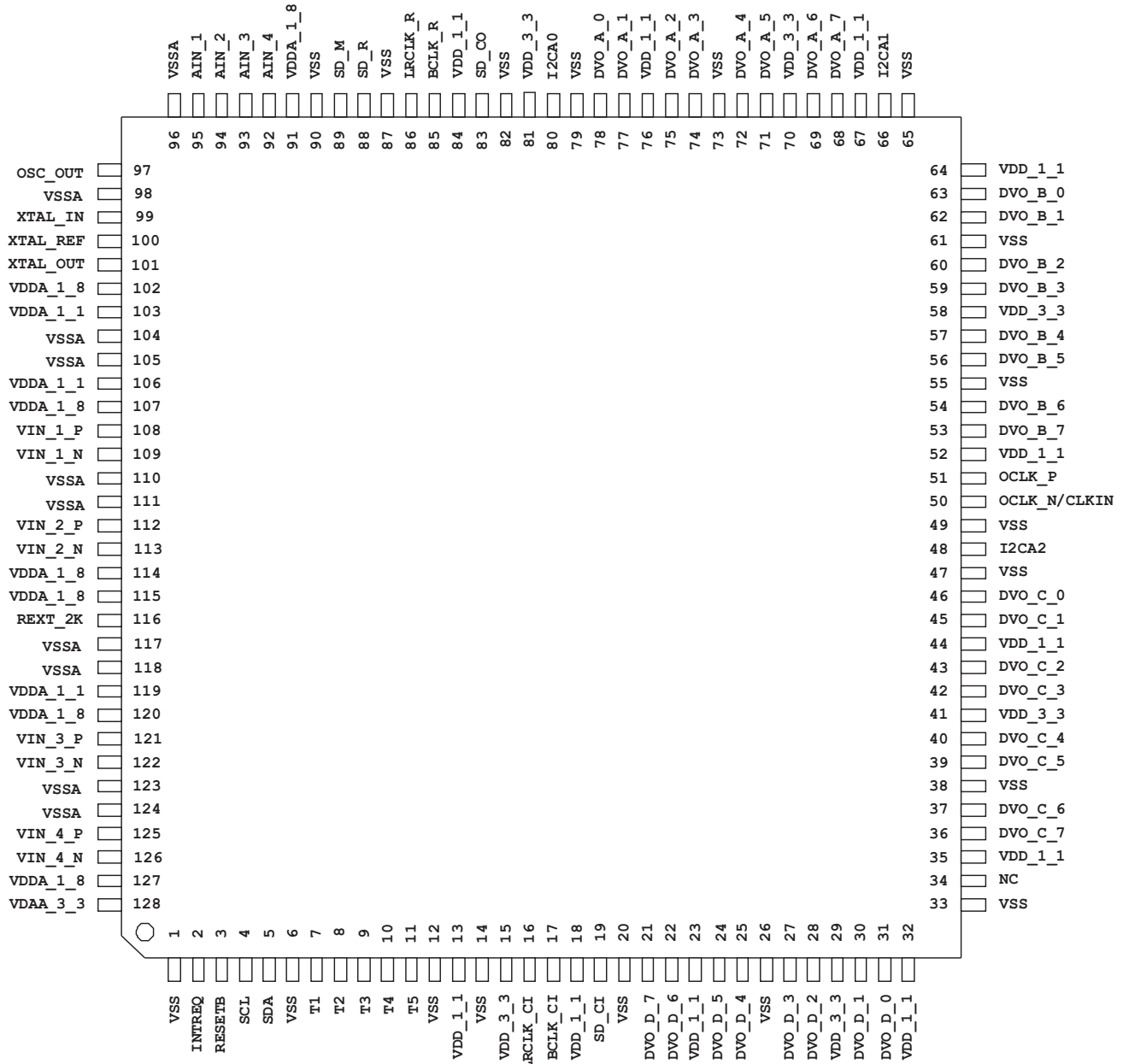

Figure 1-1. Functional Block Diagram

## 2 Terminal Assignments

### 2.1 Pinout

128-PIN TQFP PACKAGE  
(TOP VIEW)



**Table 2-1. Terminal Functions**

TERMINAL		I/O	DESCRIPTION
NAME	NO.		
<b>Analog Section</b>			
VIN_1_P	108	I	Analog video input for ADC channel 1.
VIN_1_N	109	I	Common-mode reference input for ADC channel 1.
VIN_2_P	112	I	Analog video input for ADC channel 2.
VIN_2_N	113	I	Common-mode reference input for ADC channel 2.
VIN_3_P	121	I	Analog video input for ADC channel 3.
VIN_3_N	122	I	Common-mode reference input for ADC channel 3.
VIN_4_P	125	I	Analog video input for ADC channel 4.
VIN_4_N	126	I	Common-mode reference input for ADC channels.
REXT_2K	116	I	External resistor for AFE bias generator. Connect external 1.8kΩ resistor to ground.
AIN_1	95	I	Analog audio input for channel 1 (No Connect for TVP5156 Only)
AIN_2	94	I	Analog audio input for channel 2 (No Connect for TVP5156 Only)
AIN_3	93	I	Analog audio input for channel 3 (No Connect for TVP5156 Only)
AIN_4	92	I	Analog audio input for channel 4 (No Connect for TVP5156 Only)
XTAL_IN	99	I	External clock reference input. It may be connected to external oscillator with 1.8-V compatible clock signal or 27.0-MHz crystal oscillator.
XTAL_REF	100	G	Crystal reference. Connected to analog ground internally.
XTAL_OUT	101	O	External clock reference output. Not connected if XTAL_IN is driven by an external single-ended oscillator.
<b>Analog Power</b>			
VDDA_1_1	103, 106, 119	P	1.1-V analog supply
VDDA_1_8	91, 102, 107, 114, 115, 120, 127	P	1.8-V analog supply
VDDA_3_3	128	P	3.3-V analog supply for all 4 video channels
VSSA	96, 98, 104, 105, 110, 111, 117, 118, 123, 124	G	Analog ground
<b>Digital Power</b>			
VSS	1, 6, 12, 14, 20, 26, 33, 38, 47, 49, 55, 61, 65, 73, 79, 82, 87, 90	G	Digital ground
VDD_1_1	13, 18, 23, 32, 35, 44, 52, 64, 67, 76, 84	P	Digital core supply. Connect to 1.1-V digital supply.
VDD_3_3	15, 29, 41, 58, 70, 81	P	Digital I/O supply. Connect to 3.3-V digital supply.
<b>Digital Section</b>			
INTREQ	2	O	Interrupt request. Interrupt signal to host processor.
RESETB	3	I	Reset. An active low signal that controls the reset state.
SCL	4	I/O	I <sup>2</sup> C serial clock (open drain)
SDA	5	I/O	I <sup>2</sup> C serial data (open drain)
OSC_OUT	97	O	Buffered crystal oscillator output. 1.8-V compatible.
OCLK_P	51	O	Output data clock+. All four digital video output ports are synchronized to this clock.
OCLK_N/CLKIN	50	I/O	Output data clock- for 2-Ch time-multiplexed mode or data clock input for 8-Ch video cascade mode
DVO_A [7:0]	68, 69, 71, 72, 74, 75, 77, 78	O	Digital video output data bus.

**Table 2-1. Terminal Functions (continued)**

TERMINAL		I/O	DESCRIPTION
NAME	NO.		
DVO_B_[7:0]	53, 54, 56, 57, 59, 60, 62, 63	O	Digital video output data bus.
DVO_C_[7:0]	36, 37, 39, 40, 42, 43, 45, 46	I/O	Digital video output data bus. In cascade mode, all pins operate as input from another TVP5158 device.
DVO_D_[7:0]	21, 22, 24, 25, 27, 28, 30, 31	I/O	Digital video output data bus. In cascade mode, all pins operate as input from another TVP5158 device.
I2CA0	80	I	I <sup>2</sup> C slave address bit 0
I2CA1	66	I	I <sup>2</sup> C slave address bit 1
I2CA2	48	I	I <sup>2</sup> C slave address bit 2
<b>Digital Audio Section (Not supported on TVP5156)</b>			
BCLK_R	85	I/O	I <sup>2</sup> S bit clock for recording. Also known as I <sup>2</sup> S serial clock (SCK). Supports master and slave modes.
LRCLK_R	86	I/O	I <sup>2</sup> S left/right clock for recording. Also known as I <sup>2</sup> S word select (WS). Supports master and slave modes.
SD_R	88	O	I <sup>2</sup> S serial data output for recording.
SD_M	89	O	I <sup>2</sup> S serial data output for mixed audio or recording.
SD_CO	83	O	Audio serial data output for cascade mode
LRCLK_CI	16	I	I <sup>2</sup> S left/right clock input for cascade mode. Also known as I <sup>2</sup> S word select (WS).
BCLK_CI	17	I	I <sup>2</sup> S bit clock input for cascade mode. Also known as I <sup>2</sup> S serial clock (SCK).
SD_CI	19	I	Audio serial data input for cascade mode.
<b>No Connect Pins</b>			
T1, T2, T3, T4, T5, NC	7, 8, 9, 10, 11, 34	NC	For normal operation, no connect

### 3 Functional Description

#### 3.1 Analog Video Processing and A/D Converters

Each video decoder accepts one composite video input and performs video clamping, anti-aliasing filtering, video amplification, A/D conversion, and gain and offset adjustments to center the digitized video signal. Figure 3-1 shows the video analog processing and ADC block diagram.

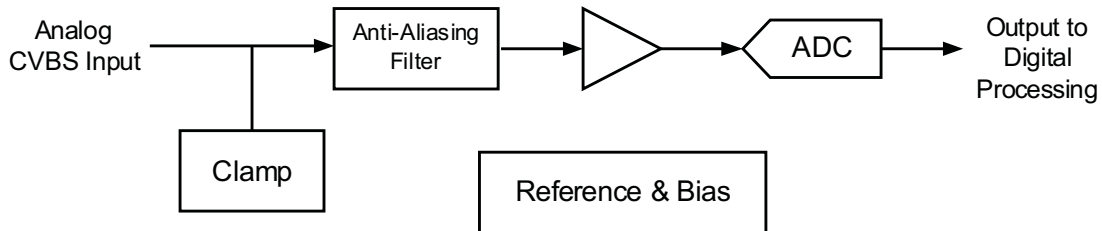

Figure 3-1. Video Analog Processing and ADC Block Diagram

##### 3.1.1 Analog Video Input

Supports NTSC (J, M, 4.43) and PAL (B, D, G, H, I, M, N, Nc, 60) video standards. Each video decoder channel supports a composite video input with a pseudo-differential pin which improves the noise immunity and analog performance.

Each video decoder input should be ac-coupled through a 0.1- $\mu$ F capacitor. The nominal parallel termination resistor before the input to the device is 75  $\Omega$ .

Each video decoder integrates an anti-aliasing filter to provide good stop-band rejection on the analog video input signal. Figure 3-2 shows the frequency response of the anti-aliasing filter.

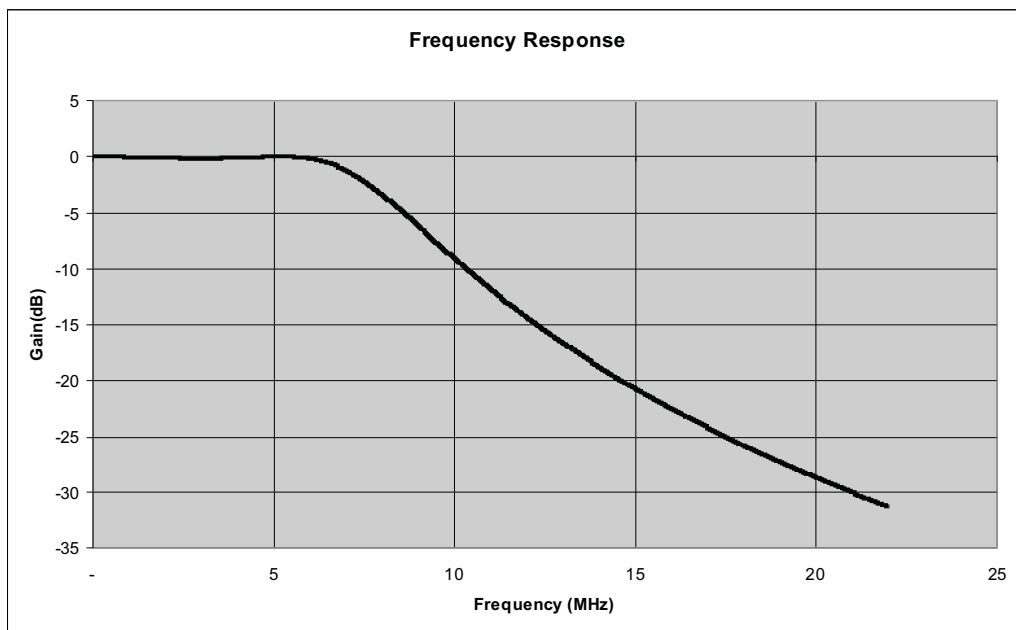

Figure 3-2. Anti-Aliasing Filter Frequency Response

### 3.1.2 Analog Video Input Clamping

An internal clamping circuit provides dc restoration for all four analog composite video inputs. The dc restoration circuit (sync-tip clamp) restores sync-tip level of the ac-coupled composite video signal to a fixed dc level near the bottom of the A/D converter range.

### 3.1.3 A/D Converter

All ADCs have a resolution of 10 bits and can operate at 27 MSPS. Each A/D channel receives a clock from the on-chip phase-locked loop (PLL) at a nominal frequency of 27 MHz. All ADC reference voltages are generated internally.

## 3.2 Digital Video Processing

Digital Video Processing block receives digitized video signals from the ADCs and performs composite processing and YCbCr signal enhancements. The digital data output can be programmed to two formats: ITU-R BT.656 8-bit 4:2:2 with embedded syncs or 16-bit 4:2:2 with embedded syncs. The circuit also detects pseudo-sync pulses, AGC pulses, and color striping in Macrovision-encoded copy-protected material.

### 3.2.1 2x Decimation Filter

All input signals are over-sampled by a factor of 2 (by 27-MHz clock). The A/D outputs initially pass through decimation filters that reduce the data rate to 1x the pixel rate. The decimation filter is a half-band filter. Over-sampling and decimation filtering can effectively increase the overall signal-to-noise ratio by 3 dB.

### 3.2.2 Automatic Gain Control

The automatic gain control (AGC) can be enabled and can adjust the signal amplitude controlled by 14-bit digital gain stage after the ADC. The AGC algorithms can use up to four amplitude references: sync height, color burst amplitude, composite peak, and luma peak.

The specific amplitude references being used by the AGC algorithms can be controlled using the AGC white peak processing register located at subaddress 2Dh. The gain increment speed and gain increment delay can be controlled using the AGC increment speed register located at subaddress 29h and the AGC increment delay register located at subaddress 2Ah. The gain decrement speed and gain decrement delay can be controlled using the AGC decrement speed register located at subaddress 2Bh and the AGC decrement delay register located at subaddress 2Ch.

### 3.2.3 Composite Processor

This Composite Processor circuit receives a digitized composite signal from the ADCs and performs sync and Y/C separation, chroma demodulation for PAL/NTSC, and YUV signal enhancements. The slice levels of the sync separator are adaptive. The slice levels continually adapt to changes in the back-porch and sync-tip levels. The 10-bit composite video is multiplied by the sub carrier signals in the quadrature demodulator to generate U and V color difference signals. The U and V signals are then sent to low-pass filters to achieve the desired bandwidth. An adaptive 5-line comb filter separates UV from Y based on the unique property of color phase shifts from line to line. The chroma is re-modulated through a quadrature modulator and subtracted from line-delayed composite video to generate luma. This form of Y/C separation is completely complementary, thus there is no loss of information. However, in some applications, it is desirable to limit the U/V bandwidth to avoid crosstalk. In that case, notch filters can be turned on. To accommodate some viewing preferences, a peaking filter is also available in the luma path. Contrast, brightness, sharpness, hue, and saturation controls are programmable through the I<sup>2</sup>C host port. [Figure 3-3](#) shows the block diagram of Composite Processor.



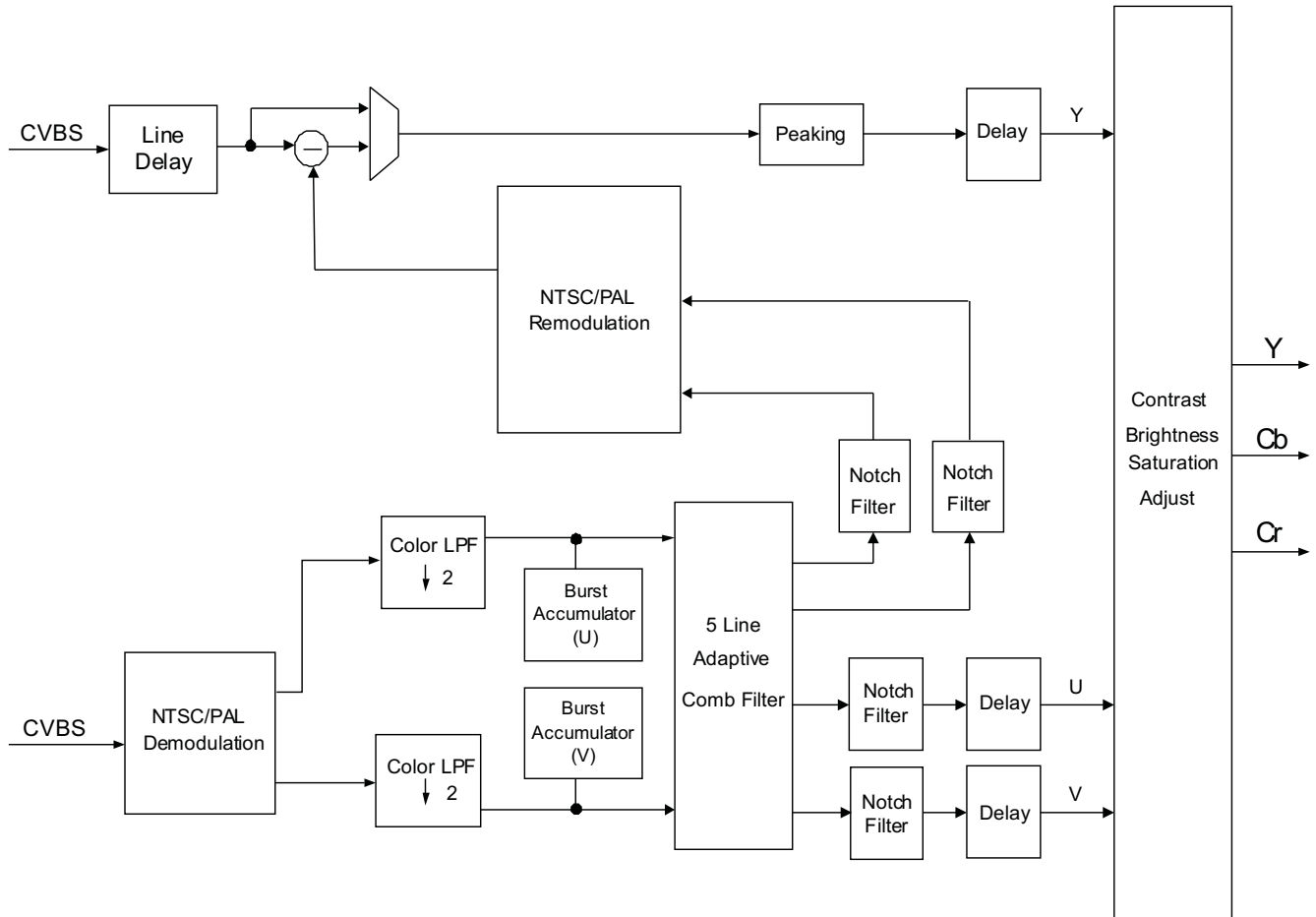

Figure 3-3. Composite Processor Block Diagram

### 3.2.3.1 Color Low-Pass Filter

High filter bandwidth preserves sharp color transitions and produces crisp color boundaries. However, for nonstandard video sources that have asymmetrical U and V side bands, it is desirable to limit the filter bandwidth to avoid UV crosstalk. The color low-pass filter bandwidth is programmable to enable one of the three notch filters. [Figure 3-4](#) and [Figure 3-5](#) represent the frequency responses of the wideband color low-pass filters.

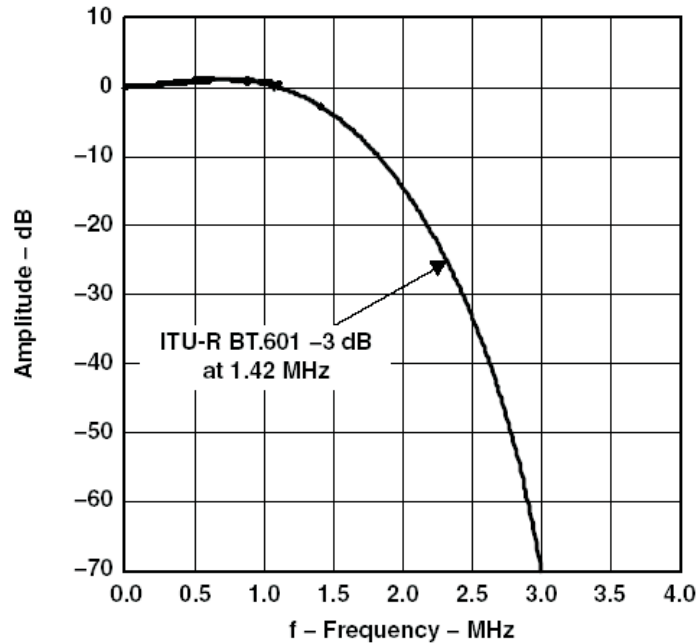

Figure 3-4. Color Low-Pass Filter Frequency Response

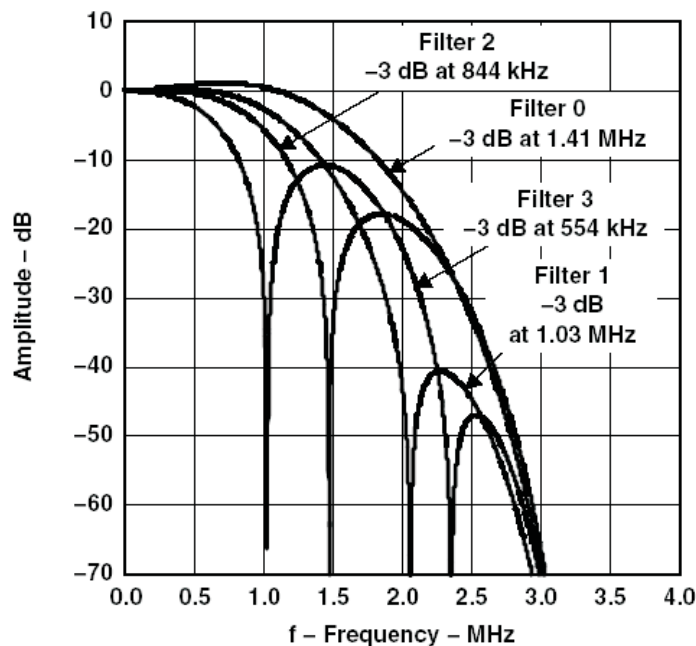

Figure 3-5. Color Low-Pass Filter with Filter Characteristics, NTSC/PAL ITU-R BT.601 Sampling

### 3.2.3.2 Y/C Separation

Y/C separation can be done using adaptive 5-line (5-H delay) comb filters or a chroma trap filter. The comb filter can be selectively bypassed in the luma or chroma path. If the comb filter is bypassed in the luma path, then chroma trap filters are used which are shown in [Figure 3-6](#) and [Figure 3-7](#). The TI patented adaptive comb filter algorithm reduces artifacts such as hanging dots at color boundaries. It detects and properly handles false colors in high-frequency luminance images such as a multiburst pattern or circle pattern.

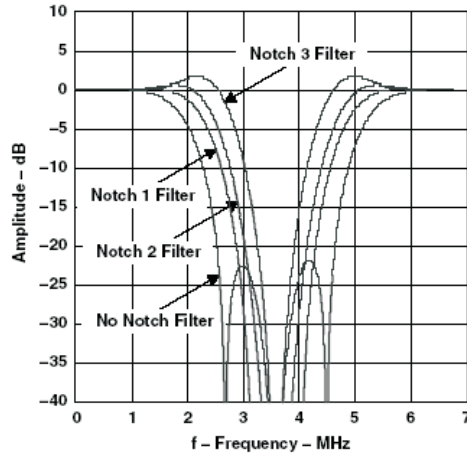

Figure 3-6. Chroma Trap Filter Frequency Response, NTSC ITU-R BT.601 Sampling

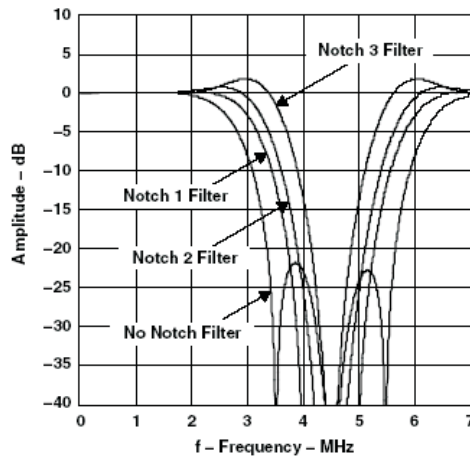

Figure 3-7. Chroma Trap Filter Frequency Response, PAL ITU-R BT.601 Sampling

### 3.2.4 Luminance Processing

The digitized composite video signal passes through either a luminance comb filter or a chroma trap filter, either of which removes chrominance information from the composite signal to generate a luminance signal. The luminance signal is then fed into the input of a peaking circuit. Figure 3-8 shows the basic functions of the luminance data path. A peaking filter (edge enhancer) amplifies high-frequency components of the luminance signal. Figure 3-9 shows the characteristics of the peaking filter at four different gain settings that are user-programmable via the I<sup>2</sup>C interface.

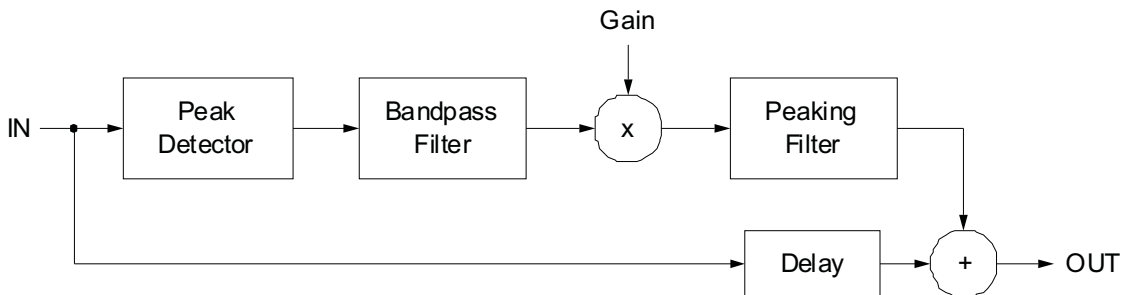

Figure 3-8. Luminance Edge-Enhancer Peaking Block Diagram

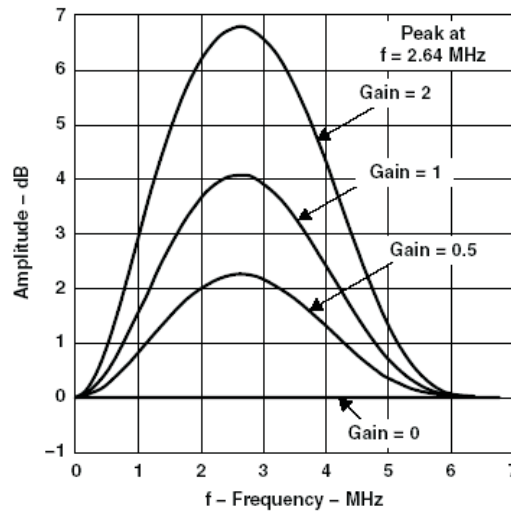

Figure 3-9. Peaking Filter Response, NTSC/PAL ITU-R BT.601 Sampling

### 3.3 AVID Cropping

AVID or active video cropping provides a means to decrease the amount of video data output. This is accomplished by horizontally blanking a number of AVID pulses and by vertically blanking a number of lines per frame. Horizontal cropping can be enabled/disabled using bit-6 of address B1h. When line cropping is enabled, active video is reduced from 720 to 704 pixels for unscaled video and from 360 to 352 pixels for down-scaled video.

When line cropping is enabled, the TVP5158 crops an equal amount from both the start and end of active video. Register 8Ch can be used to delay both the start and end of active video. It allows selecting which 704 pixels out of 720 are actually being used for active video when line cropping is enabled.

### 3.4 Embedded Syncs

Standards with embedded syncs insert SAV and EAV codes into the data stream at the beginning and end of horizontal blanking. These codes contain the V and F bits which also define vertical timing. F and V change on EAV. Table 3-1 gives the format of the SAV and EAV codes.

H equals 1 always indicates EAV. H equals 0 always indicates SAV. The alignment of V and F to the line and field counter varies depending on the standard. Please refer to ITU-R BT.656 for more information on embedded syncs.

The P bits are protection bits:

$$P3 = V \text{ xor } H$$

$$P2 = F \text{ xor } H$$

$$P1 = F \text{ xor } V$$

$$P0 = F \text{ xor } V \text{ xor } H$$

Table 3-1. EAV and SAV Sequence

	8-BIT DATA							
	D7 (MSB)	D6	D5	D4	D3	D2	D1	D0
Preamble	1	1	1	1	1	1	1	1
Preamble	0	0	0	0	0	0	0	0
Preamble	0	0	0	0	0	0	0	0
Status word	1	F	V	H	P3	P2	P1	P0

### 3.5 Scaler

Each video decoder has an independent horizontal and vertical scaler, which supports D1 to half-D1 or CIF conversion. [Table 3-2](#) gives the details of video resolution including un-cropped and cropped. [Table 3-3](#) shows the video resolutions converted by the scaler.

**Table 3-2. Standard Video Resolutions**

Format	Uncropped		Cropped	
	NTSC	PAL	NTSC	PAL
D1	720 x 480	720 x 576	704 x 480	704 x 576
Half-D1	360 x 480	360 x 576	352 x 480	352 x 576
CIF	360 x 240	360 x 288	352 x 240	352 x 288

**Table 3-3. Video Resolutions Converted by the Scaler**

Scaling Ratio	Format	Horizontal Scaling	Vertical Scaling	Total Pixel	Active Output Resolution
D1	NTSC	1:1	1:1	858 x 525	720 x 480
	PAL	1:1	1:1	864 x 625	720 x 576
D1 to Half-D1	NTSC	2:1	1:1	429 x 525	360 x 480
	PAL	2:1	1:1	432 x 625	360 x 576
D1 to CIF	NTSC	2:1	2:1	429 x 262	360 x 240
	PAL	2:1	2:1	432 x 312	360 x 288

### 3.6 Noise Reduction

A video sequence shot under low light condition, which is typical of video surveillance applications, can contain lots of noise. Human eyes are very sensitive to oscillating signals, the visual quality degenerates significantly even when the noise level is small.

Each video decoder uses a TI proprietary spatial filter to reduce video noise. For each frame of image, the video noise filter (VNF) produces an estimate of the Y/U/V noise. Based on the noise estimates, the firmware adjusts the threshold for Y/U/V filtering. The filtered video shows improved video quality and lower compression bit-rate. The firmware can also utilize the Y/U/V noise estimates to make decisions to disable color if the video noise is determined to be too high. This "color killer" decision bit can be used to control another module that implements the color killing function.

The Noise Reduction can be controlled using I<sup>2</sup>C registers from 5Ch to 5Fh. This module can also be set to bypass mode by I<sup>2</sup>C register 5Dh (Bit 0).

### 3.7 Auto Contrast

The Auto Contrast (AC) module can adjust the picture brightness automatically or manually (user programmable) for better image quality. The goal of AC processing is to make the dark area brighter and high-light area dimmer. This makes it possible for the viewer to see details hidden in the shadows. It also prevents loss of details in the washed-out high light area. The AC processing is mostly for video surveillance applications.

For each frame of image, the auto contrast module collects the statistics of its Y (luminance) values. The AC algorithm implemented in the firmware processes the statistics and generates a look-up table (LUT). This LUT is used to map each incoming pixel Y value to an output pixel Y value for the next frame of image. The LUT is updated during the blanking period between two frames.

The Auto Contrast Mode can be controlled by using I<sup>2</sup>C registers 0Fh. This module can also be set to disable mode by I<sup>2</sup>C register 0Fh (Bit 1:0).

### 3.8 Output Formatter

The output formatter is responsible for generating the output digital video stream. [Table 3-4](#) provides a summary of line frequencies, data rates, and pixel counts for different input standards. TVP5158 supports non-interleaved output mode, pixel-interleaved output mode and line-interleaved output mode. The non-interleaved mode is similar to the TVP5154A device, except that a single fixed clock output is used. In the interleaved modes, the video output data from multiple decoder channels are multiplexed together and then output to a single 8-bit or 16-bit port. The video output data from selected channels can be interleaved on a pixel or line basis.

**Table 3-4. Summary of Line Frequencies, Data Rates and Pixel Counts for Different Standards**

Standards (ITU-R BT.601)	Pixels per Line	Active Pixels per Line	Lines per Frame	Pixel Frequency (MHz)	Color Subcarrier Frequency (MHz)	Horizontal Line Rate (kHz)
NTSC-J, M	858	720	525	13.5	3.579545	15.73426
NTSC-4.43	858	720	525	13.5	4.43361875	15.73426
PAL-M	858	720	525	13.5	3.57561149	15.73426
PAL-60	858	720	525	13.5	4.43361875	15.73426
PAL-B, D, G, H, I	864	720	625	13.5	4.43361875	15.625
PAL-N	864	720	625	13.5	4.43361875	15.625
PAL-Nc	864	720	625	13.5	3.58205625	15.625

#### 3.8.1 Non-Interleaved Mode

In the non-interleaved mode, the YCbCr digital output is programmed as 8-bit ITU-R BT.656 parallel interface standard. Depending on which output mode is selected, the output for each channel can be unscaled data or scaled data. Also each video output port can be selected to output the video data from any 1 of 4 video decoders. [Table 3-5](#) shows the detailed information about non-interleaved mode.

**Table 3-5. Output Ports Configuration for Non-Interleaved Mode**

Video Output Format	Cascade Stage	I <sup>2</sup> C Address: B0h	OCLK (MHz)	Port A	Port B	Port C	Port D
1-Ch D1	n/a	00h	27	Any 1 of 4 Ch	Any 1 of 4 Ch	Any 1 of 4 Ch	Any 1 of 4 Ch
1-Ch Half-D1	n/a	02h	27	Any 1 of 4 Ch	Any 1 of 4 Ch	Any 1 of 4 Ch	Any 1 of 4 Ch
1-Ch CIF	n/a	03h	27	Any 1 of 4 Ch	Any 1 of 4 Ch	Any 1 of 4 Ch	Any 1 of 4 Ch

#### 3.8.2 Pixel-Interleaved Mode

Each video decoder supports multiplexing two or four channels ITU-R BT.656 format data together on a pixel basis. The output from each video decoder channel is still ITU-R BT.656 format. After the processing in output formatter, two or four channels video data has been interleaved together by strictly one pixel from each channel.

The pixel-interleaved mode is dedicated for the backend chip which has limited video input ports. [Table 3-6](#) gives the output port configuration for pixel-interleaved mode.

**Table 3-6. Output Ports Configuration for Pixel-Interleaved Mode**

Video Output Format	Cascade Stage	I <sup>2</sup> C Address: B0h	OCLK (MHz)	Port A	Port B	Port C	Port D
2-Ch D1	n/a	50h	54	Any 2 of 4 Ch	Any 2 of 4 Ch	Hi-Z	Hi-Z
4-Ch D1	n/a	60h	108	All 4 Ch	Hi-Z	Hi-Z	Hi-Z
4-Ch Half-D1	n/a	62h	54	All 4 Ch	Hi-Z	Hi-Z	Hi-Z
4-Ch CIF	n/a	63h	54	All 4 Ch	Hi-Z	Hi-Z	Hi-Z

**3.8.2.1 2-Ch Pixel-Interleaved Mode**

In 2-Ch pixel-interleaved mode, the video output data with D1 resolution from two video channels is multiplexed pixel by pixel at 54 MHz. The output ports DVO\_A and DVO\_B are used in this mode. The output clocks OCLK\_P and OCLK\_N are synchronized with each channel so that the backend chip can de-multiplex each video channel data easily. The video output from each channel is compatible with ITU-R BT.656 format. Figure 3-10 shows the timing diagram for 2-Ch pixel-interleaved mode.

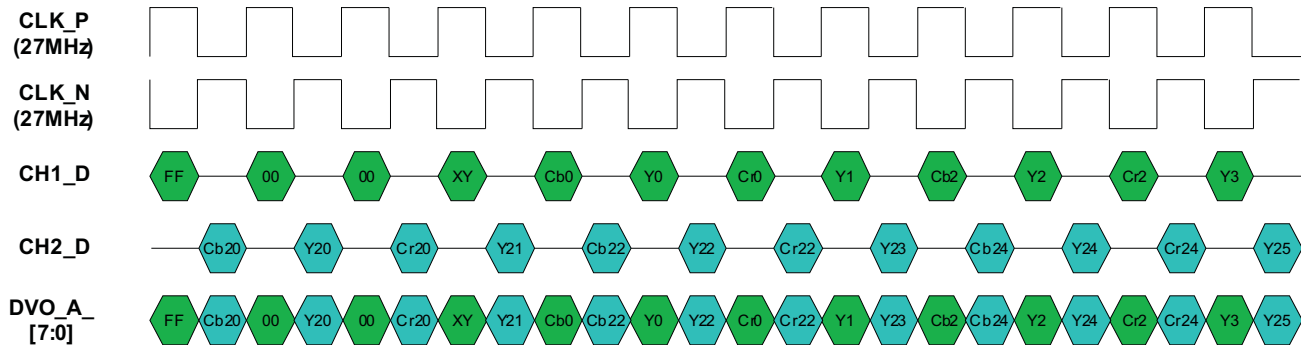

**Figure 3-10. 2-Ch Pixel-Interleaved Mode Timing Diagram**

**3.8.2.2 4-Ch Pixel-Interleaved Mode**

In 4-Ch pixel-interleaved mode, the video output data with D1 resolution from four video channels is multiplexed pixel by pixel at 108 MHz. The output DVO\_A is used in this mode. The output clock OCLK\_P is synchronized with all four channels data. Each channel video data is compatible with ITU-R BT.656 format. Figure 3-11 shows the timing diagram for 4-Ch pixel-interleaved mode.

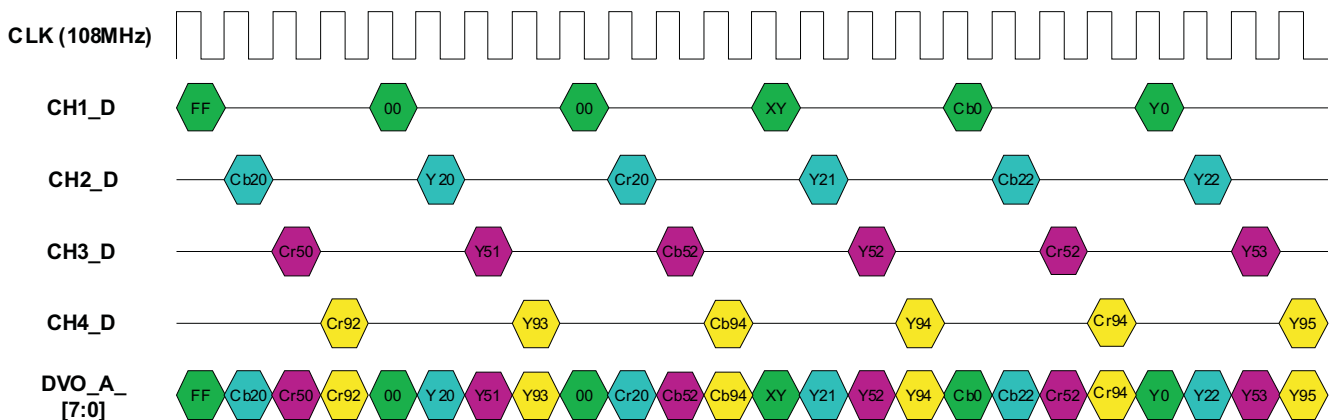

**Figure 3-11. 4-Ch Pixel-Interleaved Mode Timing Diagram**

In 4-Ch pixel-interleaved mode, TVP5158 also supports Half-D1 and CIF format data multiplexed at 54 MHz. The output DVO\_A is used in this mode. The output clock OCLK\_P is synchronized with all four channels data.

### 3.8.2.3 Metadata Insertion for Non-Interleave Mode and Pixel-Interleaved Mode

In non-interleaved mode and pixel-interleaved mode, the video detection status (VDET) has also been inserted in MSB of SAV/EAV control byte. [Table 3-7](#) shows VDET status insertion in SAV/EAV codes.

**Table 3-7. VDET Status Insertion in SAV/EAV Codes**

CONDITION			FVH VALUE			SAV/EAV CODE SEQUENCE				
FIELD	V TIME	H TIME	F	V	H	1st	2nd	3rd	4th	
									VDET = 1	VDET = 0
1	Active	SAV	0	0	0	FFh	00h	00h	80h	00h
1	Active	EAV	0	0	1	FFh	00h	00h	9Dh	1Dh
1	Blank	SAV	0	1	0	FFh	00h	00h	ABh	2Bh
1	Blank	EAV	0	1	1	FFh	00h	00h	B6h	36h
2	Active	SAV	1	0	0	FFh	00h	00h	C7h	47h
2	Active	EAV	1	0	1	FFh	00h	00h	DAh	5Ah
2	Blank	SAV	1	1	0	FFh	00h	00h	ECh	6Ch
2	Blank	EAV	1	1	1	FFh	00h	00h	F1h	71h

In the pixel-interleaved mode, Channel ID is inserted in the horizontal blanking code as [Table 3-8](#). The backend chip can easily identify the video data from which video decoder channel by inserted Channel ID.

**Table 3-8. Channel ID Insertion in Horizontal Blanking Code**

CHANNEL	H BLANKING CODE WITH CHANNEL ID		
	Y	Cb	Cr
Ch1	10h	80h	80h
Ch2	11h	81h	81h
Ch3	12h	82h	82h
Ch4	13h	83h	83h

In the pixel-interleaved mode, Channel ID can also be inserted in 4 LSBs of SAV/EAV control byte replacing protection bits as [Table 3-9](#).

**Table 3-9. Channel ID Insertion in SAV/EAV Code Sequence**

CONDITION			FVH VALUE			SAV/EAV CODE SEQUENCE						
FIELD	V TIME	H TIME	F	V	H	1st	2nd	3rd	4th			
									Ch1	Ch2	Ch3	Ch4
1	Active	SAV	0	0	0	FFh	00h	00h	80h	81h	82h	83h
1	Active	EAV	0	0	1	FFh	00h	00h	90h	91h	92h	93h
1	Blank	SAV	0	1	0	FFh	00h	00h	A0h	A1h	A2h	A3h
1	Blank	EAV	0	1	1	FFh	00h	00h	B0h	B1h	B2h	B3h
2	Active	SAV	1	0	0	FFh	00h	00h	C0h	C1h	C2h	C3h
2	Active	EAV	1	0	1	FFh	00h	00h	D0h	D1h	D2h	D3h
2	Blank	SAV	1	1	0	FFh	00h	00h	E0h	E1h	E2h	E3h
2	Blank	EAV	1	1	1	FFh	00h	00h	F0h	F1h	F2h	F3h



### 3.8.3 Line-Interleaved Mode Support (TVP5158 only)

The TVP5158 supports 2-Ch, 4-Ch, and 8-Ch line-interleaved modes. In the line-interleaved mode, the video channels are multiplexed together on a line-by-line basis. Compared to the pixel-interleaved mode, the line-interleaved mode significantly reduces the code complexity and MIPS consumption of the backend processor. The 8-Ch modes require connecting two TVP5158 devices together using a video cascade interface (see [Section 3.8.3.3](#)). The TVP5158 also supports different image resolutions (for example, D1, Half-D1, and CIF) in the line-interleaved mode. All supported line-interleaved modes are shown in [Table 3-10](#).

**Table 3-10. Output Ports Configuration for Line-Interleaved Mode**

Video Output Format	Cascade Stage	I <sup>2</sup> C Address: B0h	OCLK (MHz)	Port A	Port B	Port C	Port D
2-Ch D1	n/a	90h	54	Any 2 of 4 Ch	Any 2 of 4 Ch	Hi-Z	Hi-Z
2-Ch Half-D1	n/a	92h	27	Any 2 of 4 Ch	Any 2 of 4 Ch	Hi-Z	Hi-Z
3-Ch D1	n/a	80h	81/108	Any 3 of 4 Ch	Hi-Z	Hi-Z	Hi-Z
4-Ch D1	n/a	A0h	108	All 4 Ch	Hi-Z	Hi-Z	Hi-Z
4-Ch Half-D1	n/a	A2h	54	All 4 Ch	Hi-Z	Hi-Z	Hi-Z
4-Ch CIF	n/a	A3h	27	All 4 Ch	Hi-Z	Hi-Z	Hi-Z
4-Ch D1 (16-bit)	n/a	A8h	54	All 4 Ch (Y data)	All 4 Ch (C data)	Hi-Z	Hi-Z
4-Ch Half-D1 (16-bit)	n/a	AAh	27	All 4 Ch (Y data)	All 4 Ch (C data)	Hi-Z	Hi-Z
6-Ch Half-D1	1st	82h	81/108	6-Ch Half-D1 Output	Hi-Z	Hi-Z	2-Ch Half-D1 Input
	2nd	86h	27	2-Ch Half-D1 Output	Hi-Z	Hi-Z	Hi-Z
8-Ch Half-D1	1st	B2h	108	8-Ch Half-D1 Output	Hi-Z	Hi-Z	4-Ch Half-D1 Input
	2nd	B6h	54	4-Ch Half-D1 Output	Hi-Z	Hi-Z	Hi-Z
8-Ch CIF	1st	B3h	54	8-Ch CIF Output	Hi-Z	Hi-Z	4-Ch CIF Input
	2nd	B7h	27	4-Ch CIF Output	Hi-Z	Hi-Z	Hi-Z
4-Ch Half-D1 + 1-Ch D1	n/a	E2h	81/108	4 Ch Half-D1 + Any 1 of 4 D1	Hi-Z	Hi-Z	Hi-Z
4-Ch CIF + 1-Ch D1	n/a	E3h	54	4-Ch CIF + Any 1 of 4 D1	Hi-Z	Hi-Z	Hi-Z
6-Ch Half-D1 + 1-Ch D1	1st	C2h	108	6-Ch Half-D1 + Any 1 of 8 D1	Hi-Z	1-Ch D1 Input	2-Ch Half-D1 Input
	2nd	C6h	27	2-Ch Half-D1 Output	1-Ch D1 Output	Hi-Z	Hi-Z
8-Ch CIF + 1-Ch D1	1st	F3h	81/108	8-Ch CIF + Any 1 of 8 D1	Hi-Z	1-Ch D1 Input	4-Ch CIF Input
	2nd	F7h	27	4-Ch CIF Output	1-Ch D1 Output	Hi-Z	Hi-Z

#### 3.8.3.1 2-Ch Line-Interleaved Mode

TVP5158 supports 2-Ch line-interleaved mode at 54 MHz. The video output data with D1 resolution from any two video channels is multiplexed together on a line basis. The output ports DVO\_A and DVO\_B are used in this mode. The output clock OCLK\_P is synchronized with both output ports.

### 3.8.3.2 4-Ch Line-Interleaved Mode

In 4-Ch line-interleaved mode, the video output data from all 4 channels is multiplexed together on a line basis. The output resolution of video data can be D1, Half-D1 or CIF. For D1 and Half-D1 output resolutions, the video output port can be configured to support 8-bit BT.656 or 16-Bit YCbCr 4:2:2 data with embedded sync. Port DVO\_A is used for 8-bit output. Ports DVO\_A and DVO\_B are used for 16-Bit output. The output clock OCLK\_P is synchronized with all four output ports.

TVP5158 supports multiplexing 4-Ch CIF and 1-Ch D1 data together and then output through DVO\_A at 54 MHz. 1-Ch D1 can be from any one of 4 video channels. In typical surveillance applications, CIF resolution is used for recording and D1 resolution is used for video preview.

TVP5158 also supports multiplexing 4-Ch Half-D1 and 1-Ch D1 data together and then output through DVO\_A at 108 MHz. The backend chip can use Half-D1 to generate CIF format by dropped one field.

Please note that the line-interleaved mode does NOT strictly output one line from each decoder channel sequentially. The order of multiplexed the video line data is based on the availability of video output data from each decoder channel. Therefore, it is possible to output two consecutive lines from the same decoder channel or to skip one decoder channel output.

### 3.8.3.3 8-Ch Line-Interleaved Mode

Two TVP5158 devices can be cascade connected and work as single 8-Ch video decoder. In cascade mode, the port DVO\_C and DVO\_D of master TVP5158 (first stage) can be configured as the video input interface. The DVO\_A and DVO\_B of master TVP5158 are configured as the output interface for two devices. This mode is dedicated for the backend chip with extremely limited input ports.

In the video cascade mode, the open-drain interrupt request (INTREQ) outputs from the first and second stages can be combined using a wired-OR connection.

Typical applications with cascade mode show in the following diagrams.

[Figure 3-12](#) shows the Cascade Connection for 16-Ch CIF Recoding and Multi-Ch CIF Preview.

[Figure 3-13](#) shows the Cascade Connection for 16-Ch CIF Recoding and Multi-Ch Half-D1 Preview.

[Figure 3-14](#) shows the Cascade Connection for 16-Ch CIF Recoding and 2-Ch D1/Multi-Ch CIF Preview.

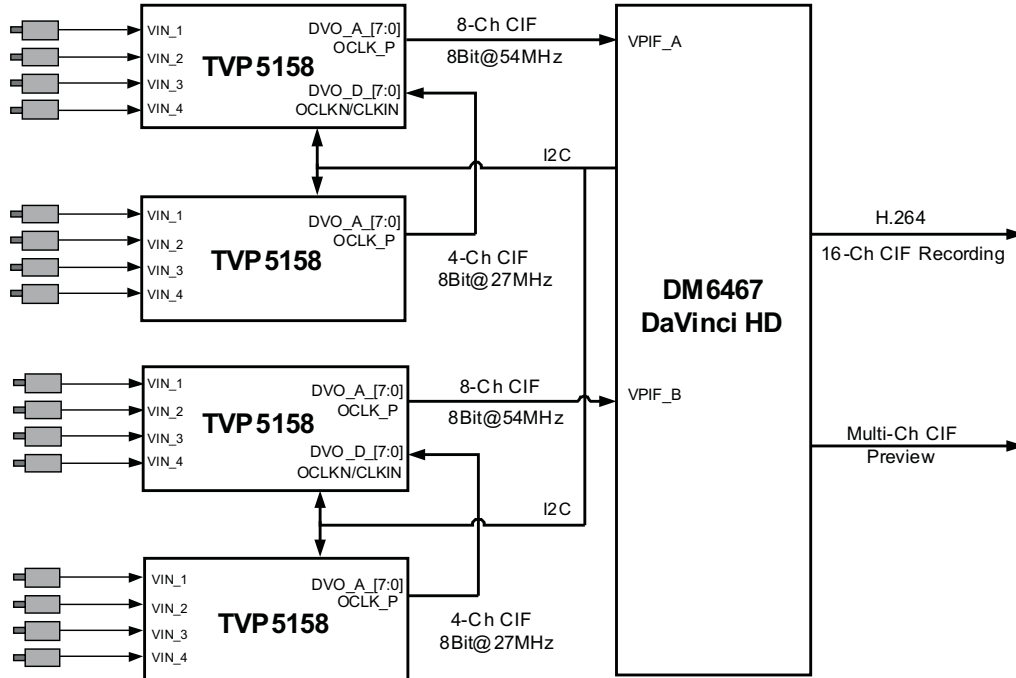

Figure 3-12. Cascade Connection for 16-Ch CIF Recoding and Multi-Ch CIF Preview

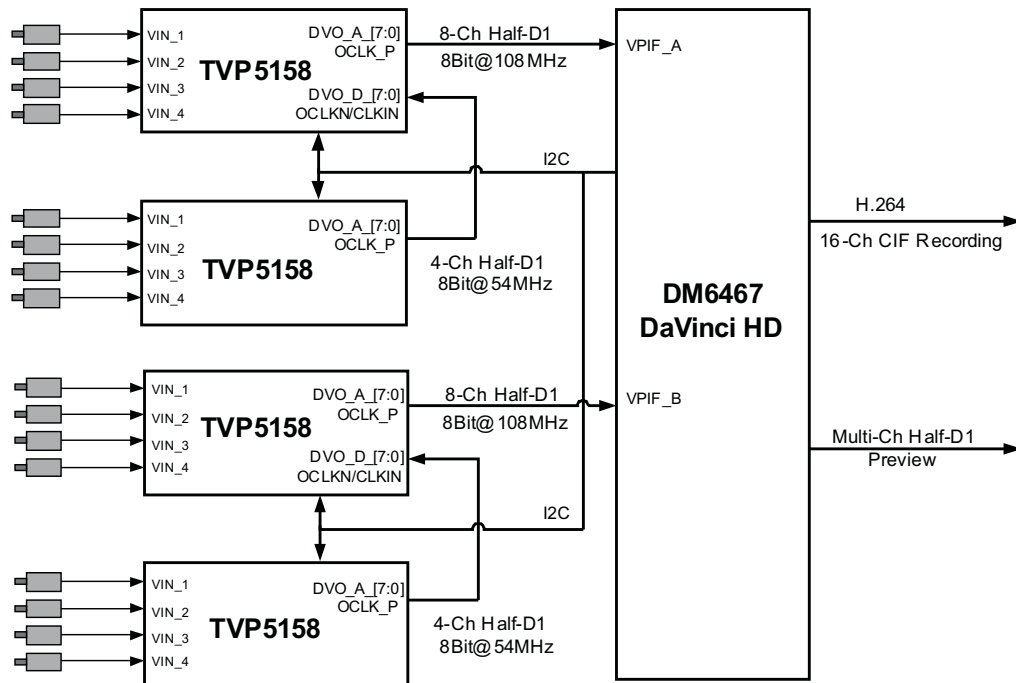

Figure 3-13. Cascade Connection for 16-Ch CIF Recoding and Multi-Ch Half-D1 Preview

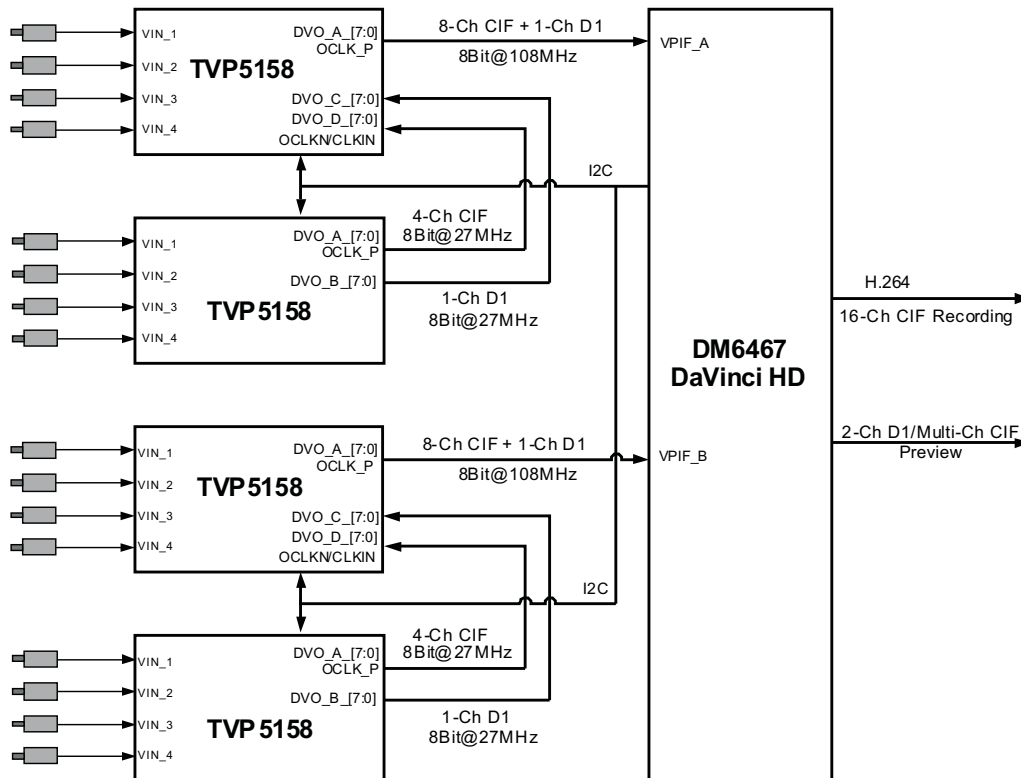

Figure 3-14. Cascade Connection for 16-Ch CIF Recoding and 2-Ch D1/Multi-Ch CIF Preview

### 3.8.3.4 Hybrid Modes

The TVP5158 also supports multiplexing both scaled and unscaled data streams in the line-interleaved mode. In these hybrid modes (4-Ch Half-D1 + 1-Ch D1, 4-Ch CIF + 1-Ch D1, and 8-Ch CIF + 1-Ch D1), the D1 line is split into two equal-length half lines and then multiplexed with the other CIF lines. Therefore, all video data is actually multiplexed by CIF line length. In these hybrid modes, the line cropping mode affects both the scaled and unscaled data streams. The line cropping mode is controlled by bit 6 of I<sup>2</sup>C register B1h.

### 3.8.3.5 Metadata Insertion for Line-Interleaved Mode

In the line-interleaved mode, the video data is rearranged on a line-by-line basis. There can be no guaranteed output line order, because all analog video inputs are not synchronized. To be compatible with general backend BT.656 decoder, the video data is encapsulated on TVP5158 output so that all input data is preserved and output data is understandable to a BT.656 decoder.

To prevent confusion over image line count and vertical blanking appearing haphazardly, SAV/EAV codes have FID and V data stripped and replaced with FID = V = 0. Because vertical blanking in the input is being masked out, artificial vertical sync is inserted every encapsulated frame (a.k.a., super frame). Thus, to the unaware BT.656 decoder, the stream appears to be progressive data with two lines of vertical blanking. The default super-frame format and timing for each line-interleaved output format is shown in [Table 3-11](#).

Table 3-11. Default Super-Frame Format and Timing

Video Output Formats	OCLK (MHz)	EAV (bytes)	EAV2SAV (bytes)		SAV (bytes)	SAV2EAV (bytes)		SF HSIZE (bytes)	SF VSIZE (bytes)
			1	0		1	0		
<b>Cropping Enable</b>	n/a	n/a	1	0	n/a	1	0	n/a	n/a
2-Ch D1	54	4	280	248	4	1416	1448	1704	1052
2-Ch Half-D1	27	4	128	112	4	712	728	848	1052
3-Ch D1 <sup>(1)</sup>	108	4	848	816	4	1416	1448	2272	1577
	81	4	280	248	4	1416	1448	1704	1577
4-Ch D1	108	4	280	248	4	1416	1448	1704	2102
4-Ch Half-D1	54	4	128	112	4	712	728	848	2102
4-Ch CIF	27	4	128	112	4	712	728	848	1054
4-Ch D1 (16 bit)	54	4	136	120	4	708	724	852	2102
4-Ch Half-D1 (16 bit)	27	4	60	52	4	356	364	424	2102
6-Ch Half-D1 <sup>(1)</sup>	108	4	416	400	4	712	728	1136	3152
	81	4	128	112	4	712	728	848	3152
8-Ch Half-D1	108	4	128	112	4	712	728	848	4095
8-Ch CIF	54	4	128	112	4	712	728	848	2106
6-Ch Half-D1 + 1-Ch D1	108	4	128	112	4	712	728	848	4095
4-Ch Half-D1 + 1-Ch D1 <sup>(1)</sup>	108	4	416	400	4	712	728	1136	3152
	81	4	128	112	4	712	728	848	3152
4-Ch CIF + 1-Ch D1	54	4	128	112	4	712	728	848	2104
8-Ch CIF + 1-Ch D1 <sup>(1)</sup>	108	4	416	400	4	712	728	1136	3156
	81	4	128	112	4	712	728	848	3156

(1) The output clock frequency for these output formats can be selected using bit 6 of I<sup>2</sup>C register B2h. The default clock frequency is 108 MHz.

4-Byte Start Code (SC3:SC0) is inserted immediately after SAV code for encapsulated frame. Figure 3-15 and Figure 3-16 show the start code details.

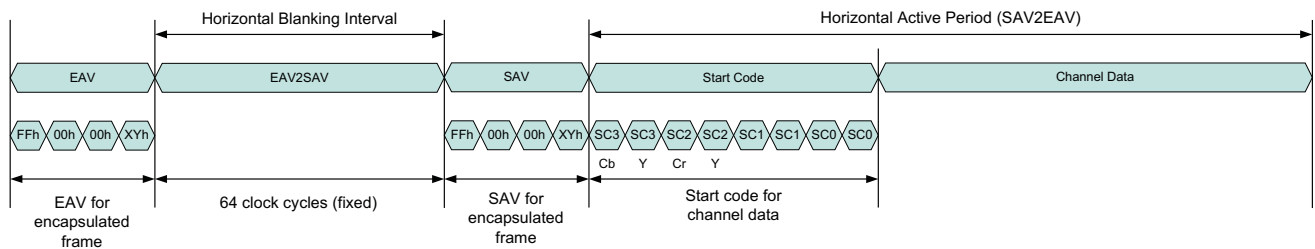

Figure 3-15. Start Code in 8-Bit BT.656 Interface

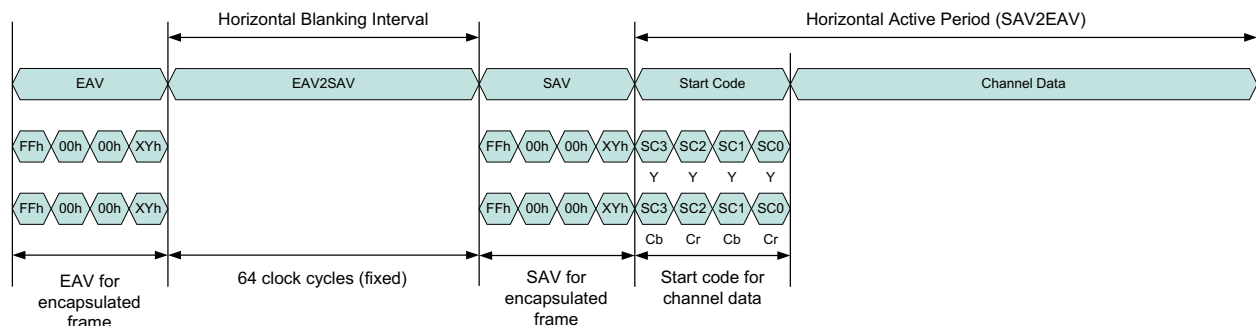

Figure 3-16. Start Code in 16-Bit YCbCr 4:2:2 Interface

Table 3-12 and Table 3-13 show the bit assignment and field definition of 4-Byte start code for Active Video Line.

**Table 3-12. Bit Assignment of 4-Byte Start Code for Active Video Line**

BYTE	7	6	5	4	3	2	1	0
SC[3]	1	BOP	EOP	RSVD		VCS_ID	CH_ID[1:0]	
SC[2]	0	BOL	EOL	VDET	RSVD		LN_ID[8:7]	
SC[1]	~LD_ID[6]	LN_ID[6:0]						
SC[0]	1	F	V	H	P3	P2	P1	P0

**Table 3-13. Bit Field Definition of 4-Byte Start Code for Active Video Line**

BIT	NAME	FUNCTION
31	1	Always set to 1.
30	BOP	Active-high beginning of period flag. Set high for first line of both active video and vertical blanking interval. In split-line mode, the BOP bit is the same for both halves of the same line. 0: Not BOP 1: BOP
29	EOP	Active-high end of period flag. Set high for last line of both active video and vertical blanking interval. In split-line mode, the EOP bit is the same for both halves of the same line. 0: Not EOP 1: EOP
[28:27]	RSVD	Reserved
26	VCS_ID	Video cascade stage ID. Set to 0 for normal operation. In cascade mode, the back-end device (for example, TMS320DM6467) interfaces to the first stage. 0: First stage (channels 1 to 4) 1: Second stage (channels 5 to 8)
[25:24]	CH_ID[1:0]	2-bit Channel ID. Video decoder channel number. 00: Channel 1 01: Channel 2 10: Channel 3 11: Channel 4
23	0	Always set to 0.
22	BOL	Active-high beginning of line flag. Used in split-line mode which may be required for hybrid formats (e.g. 1-Ch D1 + 8-Ch CIF). Set high when the current encapsulated line of channel data includes the beginning of a video line. 0: BOL not included (2nd half of split line) 1: BOL included (1st half of split line or full line)
21	EOL	Active-high end of line flag. Used in split-line mode which may be required for hybrid formats (e.g. 1-Ch D1 + 8-Ch CIF). Set high when the current line of channel data includes the end of a video line. 0: EOL not included (1st half of split line) 1: EOL included (2nd half of split line or full line)
20	VDET	Active-high video detection status 0: Video not detected 1: Video detected
[19:18]	RSVD	Reserved
[17:16]	LN_ID[8:7]	Two MSBs of 9-bit Line ID, active video line number. Line counter resets to 000h at beginning of active video (that is, resets once per field). During the vertical blanking interval, the line counter may either continue counting or hold the terminal count determined at the end of active video.
15	~LN_ID[6]	Always set to the complement of bit 14 (LN_ID[6]).
[14:8]	LN_ID[6:0]	Seven LSBs of 9-bit Line ID, active video line number. Line counter resets to 000h at beginning of active video (that is, resets once per field). During the vertical blanking interval, the line counter may either continue counting or hold the terminal count determined at the end of active video.

**Table 3-13. Bit Field Definition of 4-Byte Start Code for Active Video Line (continued)**

BIT	NAME	FUNCTION
7	1	Always set to 1.
6	F	F-bit 0: First field of frame 1: Second field of frame
5	V	V-bit 0: when not in vertical blanking 1: during vertical blanking
4	H	H-bit. Always set to 0. 0: SAV 1: EAV (never used)
3	P3	P3 = V XOR H, Protection bits used for error detection/correction
2	P2	P2 = F XOR H, Protection bits used for error detection/correction
1	P1	P1 = F XOR V, Protection bits used for error detection/correction
0	P0	P0 = F XOR V XOR H, Protection bits used for error detection/correction

---

**NOTE**

For line-interleaved output mode, if none of video decoder channels has the data ready at a given time, TVP5158 outputs the dummy line until any one of video decoder channels is ready to output a line. The backend chip needs to keep only the active video line and ignore the dummy line.

---

The start code of the dummy line is different with active video line. [Table 3-14](#) shows the bit assignment and field definition of 4-Byte start code for the Dummy Line.

**Table 3-14. Bit Assignment of 4-Byte Start Code for the Dummy Line**

BYTE	7	6	5	4	3	2	1	0
SC[3]	0	0	0	0	0	0	0	1
SC[2]	0	0	0	0	0	0	0	1
SC[1]	0	0	0	0	0	0	0	1
SC[0]	0	0	0	0	0	0	0	1

---

**NOTE**

The Dummy Line can be distinguished from active video line by looking at the MSB of byte SC[0].

---

### 3.9 Audio Sub-System (TVP5157 and TVP5158 Only)

The audio sub-system integrates a 4-Ch audio analog-to-digital converter, digital processing, and I<sup>2</sup>S encoder. TVP5158 audio sub-system supports 4-Ch mono analog audio input and standard/multiple I<sup>2</sup>S output. TVP5158 also supports audio cascade connection up to four devices cascade connected for 16-Ch audio input.

#### 3.9.1 Features

- Four mono analog audio input channels
  - Requires external passive attenuator to support 2.828-V<sub>pp</sub> analog audio input

- Programmable Gain Amplifier (PGA)
  - Gain range: -12 ~ 0 dB, Gain Step: 1.5 dB
- Integrated Anti-Aliasing Filter (AAF)
- 10-Bit Analog-to-Digital Converter
- Integrates Audio High-pass filter to eliminate low frequency hum
- Digital serial audio interface
  - 16-Bit Linear PCM, 8-Bit A-Law and 8-Bit  $\mu$ -Law Data
  - I<sup>2</sup>S or DSP Format
  - Master and Slave mode operation
  - Up to 16 slots TDM output
  - 64 f<sub>s</sub> or 256 f<sub>s</sub> system clock
- Sampling Rate : 16 kHz, 8 kHz
- Audio Cascade connection
  - Up to 4 cascaded devices
  - I<sup>2</sup>S format
  - 256 f<sub>s</sub> system clock
- Audio Mixing Output
  - Audio ADC has one register to set mix ratio
  - The Mixing output pin SD\_M can also be used for recording. Combined with the recording output pin SD\_R, two I<sup>2</sup>S bit-streams can be output simultaneously.

**3.9.2 Audio Sub-System Functional Diagram**

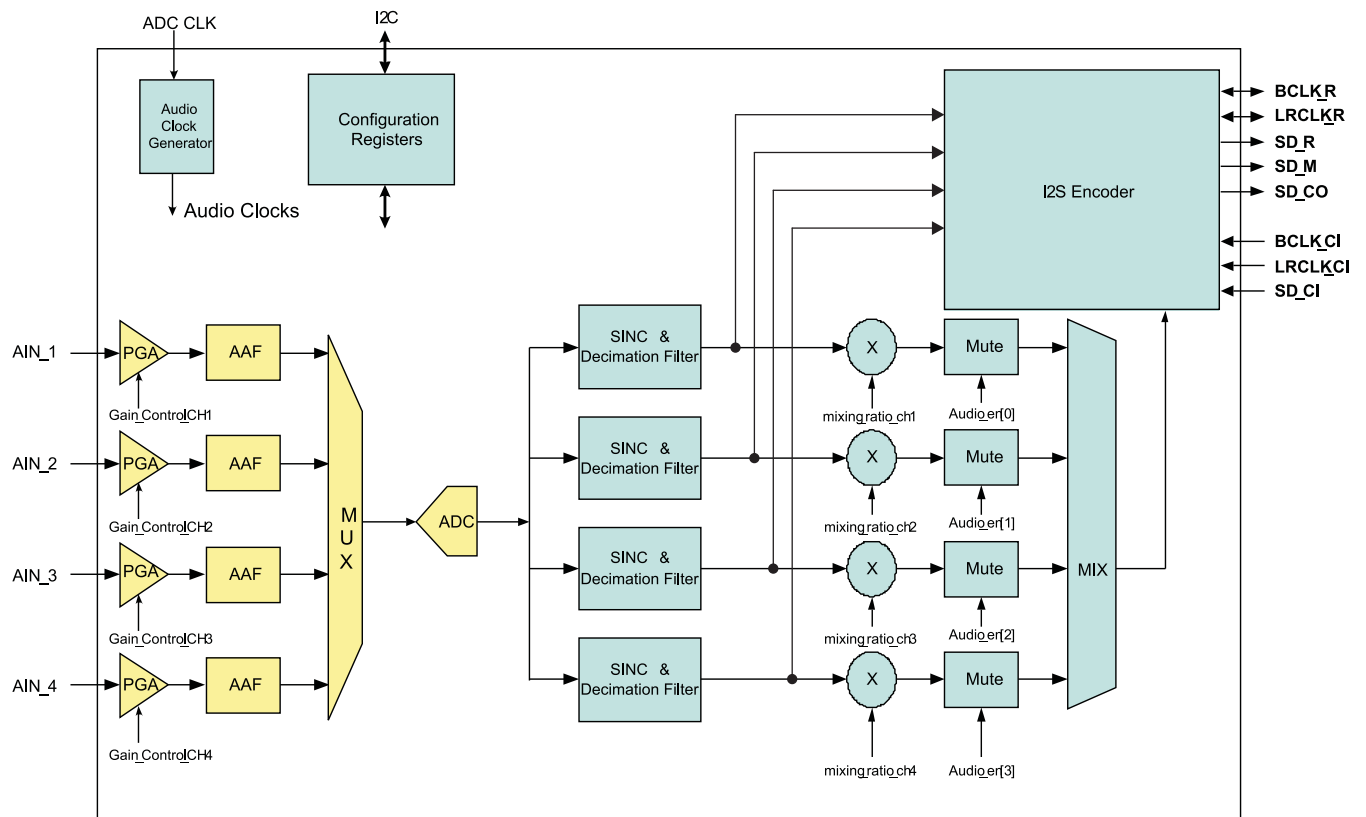

**Figure 3-17. Audio Sub-System Functional Diagram**



### 3.9.3 Serial Audio Interface

The timing for the TVP5158 serial audio interface is shown in Figure 3-18. The TVP5158 audio data output (SD\_R) and frame sync pulse (LRCLK\_R) are aligned with the falling edge of the bit clock (BCLK). The TVP5158 audio data is delayed one BCLK cycles from the falling edge of the frame sync pulse. In the DSP mode, the TVP5158 frame sync pulse is high for only one BCLK cycle.

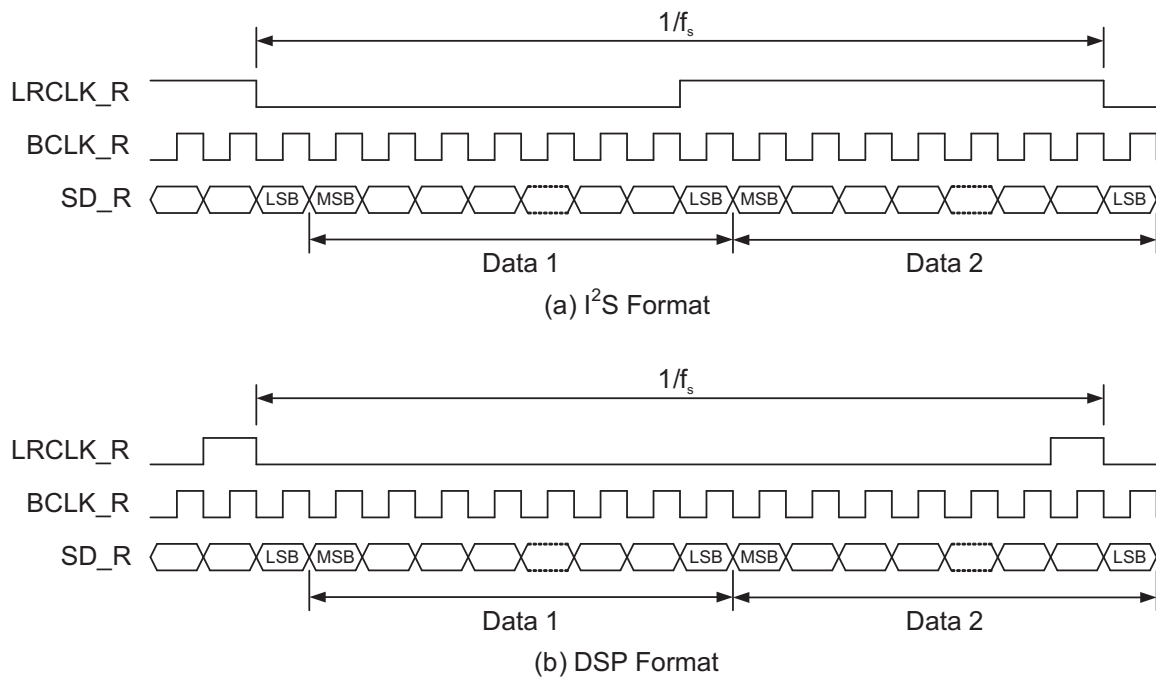
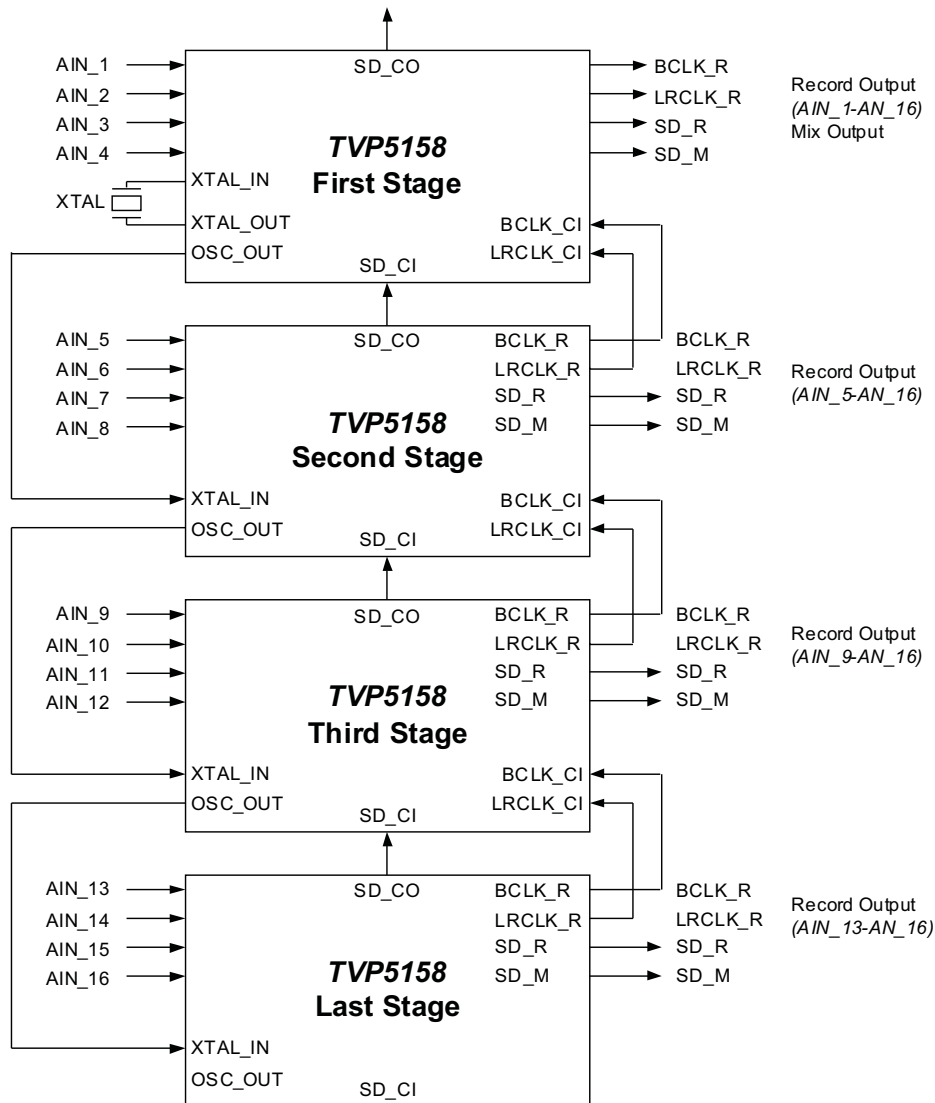

Figure 3-18. Serial Audio Interface Timing Diagram

### 3.9.4 Analog Audio Input Clamping

An internal clamping circuit provides mid-level clamping of all four analog audio inputs to a dc level of approximately 0.625 V.

### 3.9.5 Audio Cascade Connection



**Figure 3-19. Audio Cascade Connection**

TVP5158 supports up to four devices cascaded together for audio cascade connection. The I<sup>2</sup>S output of master TVP5158 (1st stage) combines all audio channel data from cascaded TVP5158 devices.

#### Key Features of Audio Cascade Connection

- 16-Bit linear PCM data
- I<sup>2</sup>S format
- Bit Clock: 256 f<sub>s</sub>
- All cascade inputs are always in slave mode
- Second to fourth stage serial audio outputs are always in master mode
- First stage serial audio output can be in either master or slave mode
- Common clock source for all cascaded devices is required

The Serial Audio Output Channel Assignment shown on [Table 3-15](#).

**Table 3-15. Serial Audio Output Channel Assignment**

I <sup>2</sup> S			LRCLK_R Left								LRCLK_R Right								
tdm_ch	tdm_out_pin		Slot 1	Slot 2	Slot 3	Slot 4	Slot 5	Slot 6	Slot 7	Slot 8	Slot 9	Slot 10	Slot 11	Slot 12	Slot 13	Slot 14	Slot 15	Slot 16	
0 (2 channel)	0	SD_R	AIN_1								AIN_2								
		SD_M																	
	1	SD_R	AIN_1																
		SD_M	AIN_2																
1 (4 channel)	0	SD_R	AIN_1	AIN_3							AIN_2	AIN_4							
		SD_M																	
	1	SD_R	AIN_1									AIN_2							
		SD_M	AIN_3									AIN_4							
2 (8 channel)	0	SD_R	AIN_1	AIN_3	AIN_5	AIN_7					AIN_2	AIN_4	AIN_6	AIN_8					
		SD_M																	
	1	SD_R	AIN_1	AIN_5								AIN_2	AIN_6						
		SD_M	AIN_3	AIN_7								AIN_4	AIN_8						
3 (12 channel)	0	SD_R	AIN_1	AIN_3	AIN_5	AIN_7	AIN_9	AIN_11				AIN_2	AIN_4	AIN_6	AIN_8	AIN_10	AIN_12		
		SD_M																	
	1	SD_R	AIN_1	AIN_5	AIN_9							AIN_2	AIN_6	AIN_10					
		SD_M	AIN_3	AIN_7	AIN_11							AIN_4	AIN_8	AIN_12					
4 (16 channel)	0	SD_R	AIN_1	AIN_3	AIN_5	AIN_7	AIN_9	AIN_11	AIN_13	AIN_15		AIN_2	AIN_4	AIN_6	AIN_8	AIN_10	AIN_12	AIN_14	AIN_16
		SD_M																	
	1	SD_R	AIN_1	AIN_5	AIN_9	AIN_13						AIN_2	AIN_6	AIN_10	AIN_14				
		SD_M	AIN_3	AIN_7	AIN_11	AIN_15						AIN_4	AIN_8	AIN_12	AIN_16				
<b>DSP Format</b>																			
tdm_ch	tdm_out_pin		Slot 1	Slot 2	Slot 3	Slot 4	Slot 5	Slot 6	Slot 7	Slot 8	Slot 9	Slot 10	Slot 11	Slot 12	Slot 13	Slot 14	Slot 15	Slot 16	
0 (2 channel)	0	SD_R	AIN_1	AIN_2															
		SD_M																	
	1	SD_R	AIN_1																
		SD_M	AIN_2																
1 (4 channel)	0	SD_R	AIN_1	AIN_3	AIN_2	AIN_4													
		SD_M																	
	1	SD_R	AIN_1	AIN_2															
		SD_M	AIN_3	AIN_4															
2 (8 channel)	0	SD_R	AIN_1	AIN_3	AIN_5	AIN_7	AIN_2	AIN_4	AIN_6	AIN_8									
		SD_M																	
	1	SD_R	AIN_1	AIN_5	AIN_2	AIN_6													
		SD_M	AIN_3	AIN_7	AIN_4	AIN_8													
3 (12 channel)	0	SD_R	AIN_1	AIN_3	AIN_5	AIN_7	AIN_9	AIN_11	AIN_2	AIN_4	AIN_6	AIN_8	AIN_10	AIN_12					
		SD_M																	
	1	SD_R	AIN_1	AIN_5	AIN_9	AIN_2	AIN_6	AIN_10											
		SD_M	AIN_3	AIN_7	AIN_11	AIN_4	AIN_8	AIN_12											
4 (16 channel)	0	SD_R	AIN_1	AIN_3	AIN_5	AIN_7	AIN_9	AIN_11	AIN_13	AIN_15		AIN_2	AIN_4	AIN_6	AIN_8	AIN_10	AIN_12	AIN_14	AIN_16
		SD_M																	
	1	SD_R	AIN_1	AIN_5	AIN_9	AIN_13	AIN_2	AIN_6	AIN_10	AIN_14									
		SD_M	AIN_3	AIN_7	AIN_11	AIN_15	AIN_4	AIN_8	AIN_12	AIN_16									

### 3.10 I<sup>2</sup>C Host Interface

The I<sup>2</sup>C standard consists of two signals, serial input/output data line (SDA) and input/output clock line (SCL), which carry information between the devices connected to the bus. The input pins I2CA0, I2CA1 and I2CA2 are used to select the slave address to which the device responds. Although the I<sup>2</sup>C system can be multi-mastered, the TVP5158 decoder functions as a slave device only.

Both SDA and SCL must be connected to IOVDD via pullup resistors. When the bus is free, both lines are high. The slave address select terminals (I2CA0, I2CA1 and I2CA2) enable the use of up to eight devices on the same I<sup>2</sup>C bus. At the trailing edge of reset, the status of the I2CA0, I2CA1 and I2CA2 lines are sampled to determine the device address used. [Table 3-16](#) summarizes the terminal functions of the I<sup>2</sup>C host interface. [Table 3-17](#) shows the device address selection options.

**Table 3-16. I<sup>2</sup>C Terminal Description**

SIGNAL	TYPE	DESCRIPTION
I2CA0	I	Slave address selection
I2CA1	I	Slave address selection
I2CA2	I	Slave address selection
SCL	I/O (open drain)	Input/output clock line
SDA	I/O (open drain)	Input/output data line

**Table 3-17. I<sup>2</sup>C Host Interface Device Addresses**

A6	A5	A4	A3	A2(I2CA2)	A1(I2CA1)	A0 (I2CA0)	R/W	HEX
1	0	1	1	0	0	0	1/0	B1/B0
1	0	1	1	0	0	1	1/0	B3/B2
1	0	1	1	0	1	0	1/0	B5/B4
1	0	1	1	0	1	1	1/0	B7/B6
1	0	1	1	1	0	0	1/0	B9/B8
1	0	1	1	1	0	1	1/0	BB/BA
1	0	1	1	1	1	0	1/0	BD/BC
1	0	1	1	1	1	1	1/0	BF/BE

Data transfer rate on the bus is up to 400 kbit/s. The number of devices connected to the bus is dependent on the bus capacitance limit of 400 pF. The data on the SDA line must be stable during the high period of the SCL except for start and stop conditions. The high or low state of the data line can only change with the clock signal on the SCL line being low. A high-to-low transition on the SDA line while the SCL is high indicates an I<sup>2</sup>C start condition. A low-to-high transition on the SDA line while the SCL is high indicates an I<sup>2</sup>C stop condition.

Every byte placed on the SDA must be 8 bits long. The number of bytes which can be transferred is unrestricted. Each byte must be followed by an acknowledge bit. The acknowledge-related clock pulse is generated by the I<sup>2</sup>C master.

To simplify programming of each of the 4 decoder channels a single I<sup>2</sup>C write transaction can be transmitted to any one or more of the 4 cores in parallel. This reduces the time required to download firmware or to configure the device when all channels are to be configured in the same manner. It also enables the addresses for all registers to be common across all decoders.

I<sup>2</sup>C subaddress FEh contains 4 bits with each bit corresponding to one of the decoder cores. If a decoder write enable bit is set, then I<sup>2</sup>C write transactions are sent to the corresponding decoder core. For multi-byte I<sup>2</sup>C write transactions, there are options to auto-increment the subaddress or to auto-increment through the selected decoders or both.

I<sup>2</sup>C subaddress FFh contains 4 bits with each bit corresponding to one of the decoder cores. If a decoder read enable bit is set, then I<sup>2</sup>C read transactions are sent to the corresponding decoder core.

If more than one decoder is enabled for reads, then the lowest numbered decoder that is enabled responds to the read transaction. For multi-byte I<sup>2</sup>C read transactions, there are options to auto-increment the subaddress or to auto-increment through the selected decoders or both.

### 3.10.1 I<sup>2</sup>C Write Operation

Data transfers occur utilizing the following formats.

An I<sup>2</sup>C master initiates a write operation to the decoder by generating a start condition (S) followed by the decoder I<sup>2</sup>C address (as shown below), in MSB first bit order, followed by a 0 to indicate a write cycle. After receiving an acknowledge from the decoder, the master presents the subaddress of the register, or the first of a block of registers it wants to write, followed by one or more bytes of data, MSB first. The decoder acknowledges each byte after completion of each transfer. The I<sup>2</sup>C master terminates the write operation by generating a stop condition (P).

<b>Step 1</b>	<b>0</b>							
I <sup>2</sup> C Start (master)	S							
<b>Step 2</b>	<b>7</b>	<b>6</b>	<b>5</b>	<b>4</b>	<b>3</b>	<b>2</b>	<b>1</b>	<b>0</b>
I <sup>2</sup> C General address (master)	1	0	1	1	1	0	X	0
<b>Step 3</b>	<b>9</b>							
I <sup>2</sup> C Acknowledge (slave)	A							
<b>Step 4</b>	<b>7</b>	<b>6</b>	<b>5</b>	<b>4</b>	<b>3</b>	<b>2</b>	<b>1</b>	<b>0</b>
I <sup>2</sup> C Write register address (master)	Addr	Addr	Addr	Addr	Addr	Addr	Addr	Addr
<b>Step 5</b>	<b>9</b>							
I <sup>2</sup> C Acknowledge (slave)	A							
<b>Step 6<sup>(1)</sup></b>	<b>7</b>	<b>6</b>	<b>5</b>	<b>4</b>	<b>3</b>	<b>2</b>	<b>1</b>	<b>0</b>
I <sup>2</sup> C Write data (master)	Data	Data	Data	Data	Data	Data	Data	Data
<b>Step 7<sup>(1)</sup></b>	<b>9</b>							
I <sup>2</sup> C Acknowledge (slave)	A							
<b>Step 8</b>	<b>0</b>							
I <sup>2</sup> C Stop (master)	P							

(1) Repeat steps 6 and 7 until all data have been written.

### 3.10.2 I<sup>2</sup>C Read Operation

The read operation consists of two phases. The first phase is the address phase. In this phase, an I<sup>2</sup>C master initiates a write operation to the decoder by generating a start condition (S) followed by the decoder slave address, in MSB first bit order, followed by a 0 to indicate a write cycle. After receiving acknowledge from the decoder, the master presents the subaddress of the register or the first of a block of registers it wants to read. After the cycle is acknowledged, the master has the option of generating a stop condition or not.

In the data phase, an I<sup>2</sup>C master initiates a read operation to the decoder by generating a start condition followed by the decoder I<sup>2</sup>C slave address (as shown below for a read operation), in MSB first bit order, followed by a 1 to indicate a read cycle. After an acknowledge from the decoder, the I<sup>2</sup>C master receives one or more bytes of data from the decoder. The I<sup>2</sup>C master acknowledges the transfer at the end of each byte. After the last data byte has been transferred from the decoder, the master generates a not acknowledge followed by a stop.

**Read Phase 1**

<b>Step 1</b>	<b>0</b>								
I <sup>2</sup> C Start (master)	S								
<b>Step 2</b>	<b>7</b>	<b>6</b>	<b>5</b>	<b>4</b>	<b>3</b>	<b>2</b>	<b>1</b>	<b>0</b>	
I <sup>2</sup> C General address (master)	1	0	1	1	X	X	X	0	
<b>Step 3</b>	<b>9</b>								
I <sup>2</sup> C Acknowledge (slave)	A								
<b>Step 4</b>	<b>7</b>	<b>6</b>	<b>5</b>	<b>4</b>	<b>3</b>	<b>2</b>	<b>1</b>	<b>0</b>	
I <sup>2</sup> C Read register address (master)	Addr	Addr	Addr	Addr	Addr	Addr	Addr	Addr	
<b>Step 5</b>	<b>9</b>								
I <sup>2</sup> C Acknowledge (slave)	A								
<b>Step 6<sup>(1)</sup></b>	<b>0</b>								
I <sup>2</sup> C Stop (master)	P								

(1) Step 6 is optional.

**Read Phase 2**

<b>Step 7</b>	<b>0</b>								
I <sup>2</sup> C Start (master)	S								
<b>Step 8</b>	<b>7</b>	<b>6</b>	<b>5</b>	<b>4</b>	<b>3</b>	<b>2</b>	<b>1</b>	<b>0</b>	
I <sup>2</sup> C General address (master)	1	0	1	1	X	X	X	1	
<b>Step 9</b>	<b>9</b>								
I <sup>2</sup> C Acknowledge (slave)	A								
<b>Step 10<sup>(1)</sup></b>	<b>7</b>	<b>6</b>	<b>5</b>	<b>4</b>	<b>3</b>	<b>2</b>	<b>1</b>	<b>0</b>	
I <sup>2</sup> C Read data (slave)	Data	Data	Data	Data	Data	Data	Data	Data	
<b>Step 11<sup>(1)</sup></b>	<b>9</b>								
I <sup>2</sup> C Not Acknowledge (master)	$\bar{A}$								
<b>Step 12</b>	<b>0</b>								
I <sup>2</sup> C Stop (master)	P								

(1) Repeat steps 10 and 11 for all bytes read. Master does not acknowledge the last read data received.

### 3.10.3 VBUS Access

The TVP5158 video decoder has additional internal registers accessible through an indirect access to an internal 24-bit address wide VBUS. Figure 3-20 shows the VBUS registers access.

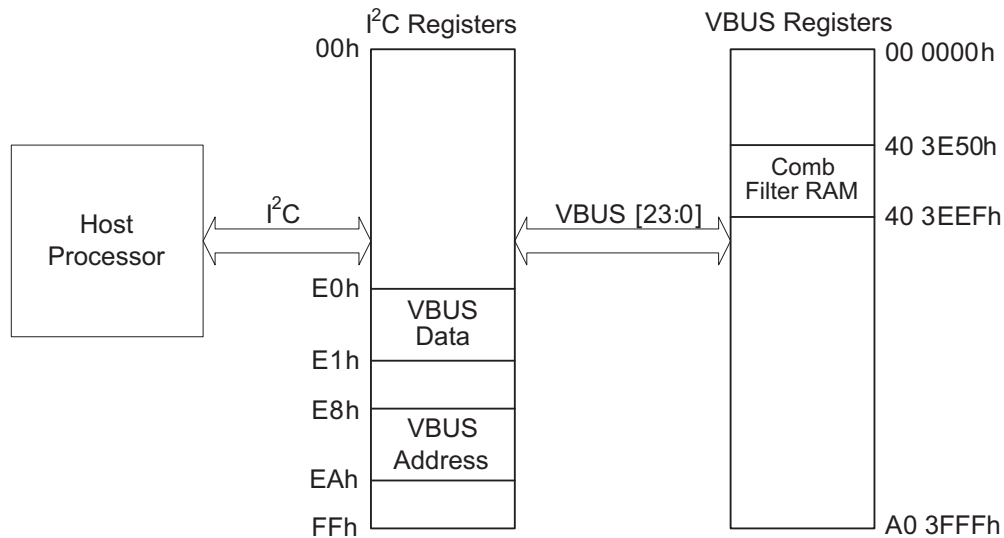

Figure 3-20. VBUS Access

#### VBUS Write

##### Single Byte

S	B8	ACK	E8	ACK	VA0	ACK	VA1	ACK	VA2	ACK	P
---	----	-----	----	-----	-----	-----	-----	-----	-----	-----	---

S	B8	ACK	E0	ACK	Send Data	ACK	P
---	----	-----	----	-----	-----------	-----	---

##### Multiple Bytes

S	B8	ACK	E8	ACK	VA0	ACK	VA1	ACK	VA2	ACK	P
---	----	-----	----	-----	-----	-----	-----	-----	-----	-----	---

S	B8	ACK	E1	ACK	Send Data	ACK	...	Send Data	ACK	P
---	----	-----	----	-----	-----------	-----	-----	-----------	-----	---

#### VBUS Read

##### Single Byte

S	B8	ACK	E8	ACK	VA0	ACK	VA1	ACK	VA2	ACK	P
---	----	-----	----	-----	-----	-----	-----	-----	-----	-----	---

S	B8	ACK	E0	ACK	S	B9	ACK	Read Data	NAK	P
---	----	-----	----	-----	---	----	-----	-----------	-----	---

##### Multiple Bytes

S	B8	ACK	E8	ACK	VA0	ACK	VA1	ACK	VA2	ACK	P
---	----	-----	----	-----	-----	-----	-----	-----	-----	-----	---

S	B8	ACK	E1	ACK	S	B9	ACK	Read Data	MACK	...	Read Data	NAK	P
---	----	-----	----	-----	---	----	-----	-----------	------	-----	-----------	-----	---

NOTE: Examples use default I<sup>2</sup>C address

ACK: Acknowledge generated by the slave

MACK: Acknowledge generated by the master

NAK: No Acknowledge generated by the master

### 3.11 Clock Circuits

An analog clock multiplier PLL is used to generate a system clock from an external 27-MHz crystal (fundamental resonant frequency) or external clock reference input. A crystal can be connected across terminals 99 (XTAL\_IN) and 101 (XTAL\_OUT), or a 1.8-V external clock input can be connected to terminal 99. Four horizontal PLLs generate the line-locked sample clock for each video decoder core from the system clock. Four color PLLs generate the color subcarrier frequency for each video decoder core from the corresponding line-locked clock. Four vertical PLLs generate the field/frame sync for each video decoder core. A frequency synthesizer generates the 32.768-MHz audio oversampling clock for each analog audio input from the system clock.

Figure 3-21 shows the reference clock configurations. For the example crystal circuit shown, the external capacitors must have the following relationship:

$$C_{L1} = C_{L2} = 2C_L - C_{STRAY}$$

Where,

$C_{STRAY}$  is the terminal capacitance with respect to ground

$C_L$  is the crystal load capacitance specified by the crystal manufacturer

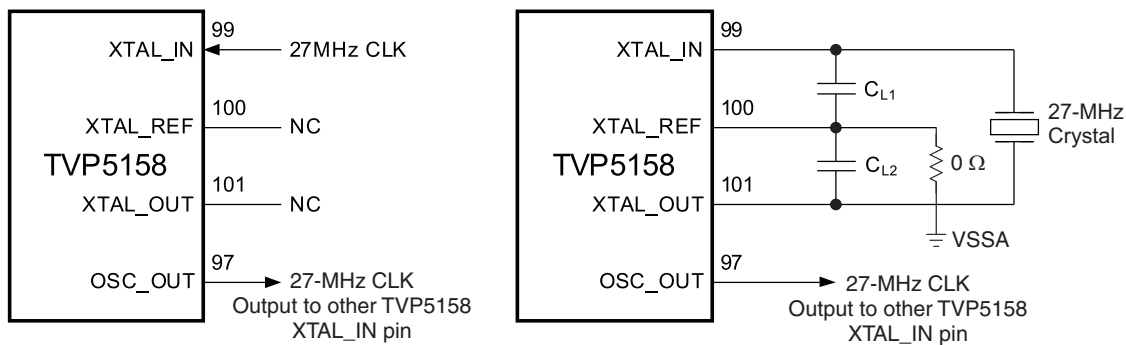

Figure 3-21. Clock and Crystal Connectivity



### 3.12 Reset Mode

Terminal 3 (RESETB) is active low signal to hold the decoder into reset. [Table 3-18](#) shows the configuration of reset mode. [Table 3-19](#) describes the status of the decoder signals during and immediately after reset. [Figure 3-22](#) shows the reset timing.

After power-up, the device is in an unknown state until properly reset. An active-low reset, Reset B, of greater than or equal to 20 ms is required following active and stable supply ramp-up. To avoid potential I<sup>2</sup>C issues, keep SCL and SDA inactive (high) for at least 260 μs after reset goes high. There are no power sequencing requirements except that all power supplies should become active and stable within 500 ms of each other.

**Table 3-18. Reset Mode**

RESETB	CONFIGURATION
0	Resets the decoder
1	Normal operation

**Table 3-19. Reset Sequence**

SIGNAL NAME	DURING RESET	RESET COMPLETED
DVO_A_[7:0], DVO_B_[7:0], DVO_C_[7:0], DVO_D_[7:0], OCLK_P, OCLK_N, INTREQ, I2CA[2:0], BCLK_R, LRCLK_R, SD_R, SD_M, SD_CO	Input	High-impedance
RESETB, SDA, SCL, LRCLK_CI, BCLK_CI, SD_CI, XTAL_IN	Input	Input
XTAL_OUT, OSC_OUT	Output	Output

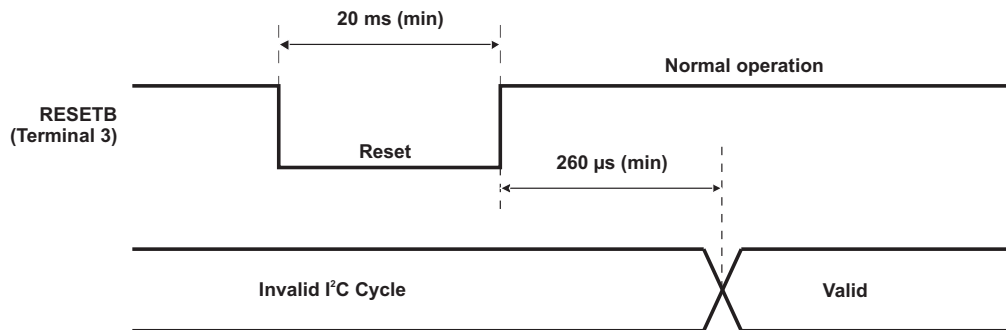

**Figure 3-22. Reset Timing**

## 4 Internal Control Registers

### 4.1 Overview

The decoder is initialized and controlled by a set of internal registers which set all device operating parameters. Communication between the external controller and the decoder is through I<sup>2</sup>C. Table 4-1 shows the summary of these registers. The reserved registers must not be written. Reserved bits in the defined registers must be written with 0s, unless otherwise noted. The detailed programming information of each register is described in the following sections.

I<sup>2</sup>C register FEh controls which of the four decoders will receive I<sup>2</sup>C commands. I<sup>2</sup>C register FFh controls which decoder core responds to I<sup>2</sup>C reads. Note that for a read operation, it is necessary to perform a write first to set the desired subaddress for reading.

Compared to previous video decoder, TVP5154A, the TVP5158, TVP5157, and TVP5156 add decoder auto increment and address auto increment bits control. If decoder auto increment bit is set, the next read/write is from/to the next decoder that is enabled. If address auto-increment bit is set, the address increments after all the decoders enabled read/writes are completed. The detail of I<sup>2</sup>C registers FEh and FFh is shown in their register section.

**Table 4-1. Registers Summary**

REGISTER NAME	I <sup>2</sup> C SUBADDRESS	DEFAULT	R/W <sup>(1)</sup>
Status 1	00h		R
Status 2	01h		R
Color Subcarrier Phase Status	02h		R
Reserved	03h		
ROM Version	04h		R
RAM Version MSB	05h		R
RAM Version LSB	06h		R
Reserved	07h		
Chip ID MSB	08h	51h	R
Chip ID LSB	09h	58h	R
Reserved	0Ah - 0Bh		
Video Standard Status	0Ch		R
Video Standard Select	0Dh	00h	R/W
CVBS Autoswitch Mask	0Eh	03h	R/W
Auto Contrast Mode	0Fh	03h	R/W
Luminance Brightness	10h	80h	R/W
Luminance Contrast	11h	80h	R/W
Brightness and Contrast Range Extender	12h	00h	R/W
Chrominance Saturation	13h	80h	R/W
Chrominance Hue	14h	00h	R/W
Reserved	15h		
Color Killer	16h	10h	R/W
Reserved	17h		
Luminance Processing Control 1	18h	40h	R/W
Luminance Processing Control 2	19h	00h	R/W
Power Control	1Ah	00h	R/W
Chrominance Processing Control 1	1Bh	00h	R/W
Chrominance Processing Control 2	1Ch	0Ch	R/W

(1) R = Read only, W = Write only, R/W = Read and write

**Table 4-1. Registers Summary (continued)**

REGISTER NAME	I <sup>2</sup> C SUBADDRESS	DEFAULT	R/W <sup>(1)</sup>
Reserved	1Dh - 1Fh		
AGC Gain Status 1	20h		R
AGC Gain Status 2	21h		R
Reserved	22h		
Back-End AGC Status	23h		R
Status Request	24h	00h	R/W
AFE Gain Control	25h	F5h	R/W
Luma ALC Freeze Upper Threshold	26h	00h	R/W
Chroma ALC Freeze Upper Threshold	27h	00h	R/W
Reserved	28h		
AGC Increment Speed	29h	06h	R/W
AGC Increment Delay	2Ah	1Eh	R/W
AGC Decrement Speed	2Bh	04h	R/W
AGC Decrement Delay	2Ch	00h	R/W
AGC White Peak Processing	2Dh	F2h	R/W
Back-End AGC Control	2Eh	08h	R/W
Reserved	2Fh - 33h		
AFE Fine Gain	34h - 35h	086Ah	R/W
Reserved	36h - 47h		
AVID Start Pixel LSBs	48h	7Ah/84h	R/W
AVID Start Pixel MSBs	49h	00h/00h	R/W
AVID Pixel Width	4Ah - 4Bh	02D0h/02D0h	R/W
Reserved	4Ch - 5Bh		
NR_Max_Noise	5Ch	28h	R/W
NR_Control	5Dh	09h	R/W
NR_Noise_Filter	5Eh - 5Fh	0330h	R/W
Operation Mode Control	60h	00h	R/W
Color PLL Speed Control	61h	09h	R/W
Reserved	62h - 7Bh		
Sync Height Low Threshold	7Ch	02h	R/W
Sync Height High Threshold	7Dh	08h	R/W
Reserved	7Eh - 80h	03h	R/W
Clear Lost Lock Detect	81h	00h	R/W
Reserved	82h - 84h		
V-Sync Filter Shift	85h	03h	R/W
Reserved	86h		
656 Version/F Bit Control	87h	00h	R/W
F- and V-Bit Decode Control	88h	00h	R/W
F- and V-Bit Control	89h	16h	R/W
Reserved	8Ah - 8Bh		
Output Timing Delay	8Ch	00h	R/W
Reserved	8Dh - 8Fh		
Auto Contrast User Table Index	8Fh	04h	R/W
Blue Screen Y Control	90h	10h	R/W
Blue Screen Cb Control	91h	80h	R/W
Blue Screen Cr Control	92h	80h	R/W
Blue Screen LSB Control	93h	00h	R/W

**Table 4-1. Registers Summary (continued)**

REGISTER NAME	I <sup>2</sup> C SUBADDRESS	DEFAULT	R/W <sup>(1)</sup>
Noise Measurement LSB	94h		R
Noise Measurement MSB	95h		R
Weak Signal High Threshold	96h	60h	R/W
Weak Signal Low Threshold	97h	50h	R/W
Reserved	98h - 9Dh		
NR_Y_T0	9Eh	0Ah	R/W
NR_U_T0	9Fh	BCh	R/W
NR_V_T0	A0h	BCh	R/W
Reserved	A1h		
Vertical Line Count Status	A2h - A3h		R
Reserved	A4h - A7H		
Output Formatter Control 1 (write to all four decoder cores)	A8h	44h	R/W
Output Formatter Control 2 (write to all four decoder cores)	A9h	40h	R/W
Reserved	AAh - ACh		
Interrupt Control	ADh	00h	R/W
Embedded Sync Offset Control 1 (write to all four decoder cores)	A Eh	01h	R/W
Embedded Sync Offset Control 2 (write to all four decoder cores)	A Fh	00h	R/W
AVD Output Control 1	B0h	00h	R/W
AVD Output Control 2	B1h	10h	R/W
OFM Mode Control	B2h	20h	R/W
OFM Channel Select 1	B3h	E4h	R/W
OFM Channel Select 2	B4h	E4h	R/W
OFM Channel Select 3	B5h	00h	R/W
OFM Super-Frame Size LSBs	B6h	1Bh	R/W
OFM Super-Frame Size MSBs	B7h	04h	R/W
OFM H-Blank Duration LSBs	B8h	40h	R/W
OFM H-Blank Duration MSBs	B9h	00h	R/W
Misc Ofm Control	BAh	00h	R/W
Reserved	BBh - BFh	00h	R/W
Audio Sample Rate Control	C0h	00h	R/W
Analog Audio Gain Control 1	C1h	88h	R/W
Analog Audio Gain Control 2	C2h	88h	R/W
Audio Mode Control	C3h	C9h	R/W
Audio Mixer Select	C4h	01h	R/W
Audio Mute Control	C5h	00h	R/W
Audio Mixing Ratio Control 1	C6h	00h	R/W
Audio Mixing Ratio Control 2	C7h	00h	R/W
Audio Cascade Mode Control	C8h	00h	R/W
Reserved	C9h	A5h	R/W
Reserved	CAh	FFh	R/W
Reserved	CBh	7Eh	R/W
Reserved	CCh	01h	R/W
Reserved	CDh - CFh		
Super-frame EAV2SAV duration status LSBs	D0h		R
Super-frame EAV2SAV duration status MSBs	D1h		R
Super-frame SAV2EAV duration status LSBs	D2h		R
Super-frame SAV2EAV duration status MSBs	D3h		R

**Table 4-1. Registers Summary (continued)**

REGISTER NAME	I <sup>2</sup> C SUBADDRESS	DEFAULT	R/W <sup>(1)</sup>
Reserved	D4h - DFh		
VBUS Data Access With No VBUS Address Increment	E0h		R/W
VBUS Data Access With VBUS Address Increment	E1h		R/W
Reserved	E2h - E7h		
VBUS Address Access	E8h - EAh	00 0000h	R/W
Reserved	EBh - F1h		R/W
Interrupt Status	F2h		R
Reserved	F3h		
Interrupt Mask	F4h	00h	R/W
Reserved	F5h		
Interrupt Clear	F6h	00h	R/W
Decoder Write Enable	FEh	0Fh	R/W
Decoder Read Enable	FFh	01h	R/W

## 4.2 Register Definitions

**Table 4-2. Status 1**

**Subaddress**      00h  
**Default**          Read only

7	6	5	4	3	2	1	0
Reserved	Line-alternating status	Field rate status	Lost lock detect	Color subcarrier lock status	Vertical sync lock status	Horizontal sync lock status	TV/VCR status

**Line-alternating status**

- 0 Non line alternating
- 1 Line alternating

**Field rate status**

- 0 60 Hz
- 1 50 Hz

**Lost lock detect**

- 0 No lost lock since this bit was last cleared
- 1 Lost lock since this bit was last cleared

**Color subcarrier lock status**

- 0 Color subcarrier is not locked
- 1 Color subcarrier is locked

**Vertical sync lock status**

- 0 Vertical sync is not locked
- 1 Vertical sync is locked

**Horizontal sync lock status**

- 0 Horizontal sync is not locked
- 1 Horizontal sync is locked

**TV/VCR status**

- 0 TV
- 1 VCR

**Table 4-3. Status 2**

**Subaddress**        01h  
**Default**            Read only

7	6	5	4	3	2	1	0
Signal present	Weak signal detection	PAL switch polarity	Field sequence status	Color killed	Macrovision detection [2:0]		

**Signal present**

0     Signal is not present  
1     Signal is present

**Weak signal detection**

0     No weak signal  
1     Weak signal mode

**PAL switch polarity**

0     PAL switch is zero  
1     PAL switch is one

**Field sequence status**

0     Even field  
1     Odd field

**Color killed**

0     Color killer is not active  
1     Color killer is active

**Macrovision detection [2:0]**

000   No copy protection  
001   AGC pulses/pseudo syncs present (Type 1)  
010   2-line colorstripe only present  
011   AGC pulses/pseudo syncs and 2-line colorstripe present (Type 2)  
100   Reserved  
101   Reserved  
110   4-line colorstripe only present  
111   AGC pulses/pseudo syncs and 4-line colorstripe present (Type 3)

**Table 4-4. Color Subcarrier Phase Status**

**Subaddress**        02h  
**Default**            Read only

7	6	5	4	3	2	1	0
Color subcarrier phase [7:0]							

This register shows the color subcarrier phase.

**Table 4-5. ROM Version**

**Subaddress**        04h  
**Default**            Read only

7	6	5	4	3	2	1	0
ROM version [7:0]							

**ROM Version [7:0]**

ROM revision number = 02h for PG 1.1

**Table 4-6. RAM Version MSB**

**Subaddress**        05h  
**Default**            Read only

7	6	5	4	3	2	1	0
RAM version MSB [7:0]							

RAM version MSB [7:0]

This register identifies the MSB of the RAM code revision number.

**Table 4-7. RAM Version LSB**

**Subaddress**        06h  
**Default**            Read only

7	6	5	4	3	2	1	0
RAM version LSB [7:0]							

RAM version LSB [7:0]

This register identifies the LSB of the RAM code revision number.

Example:

Patch Release = v02.01.22

ROM Version = 02h

RAM Version MSB = 01h

RAM Version LSB = 22h

**Table 4-8. Chip ID MSB**

**Subaddress**        08h  
**Default**            Read only

7	6	5	4	3	2	1	0
Chip ID MSB [7:0]							

Chip ID MSB[7:0]

This register identifies the MSB of device ID. Value = 51h

**Table 4-9. Chip ID LSB**

**Subaddress**        09h  
**Default**            Read only

7	6	5	4	3	2	1	0
Chip ID LSB [7:0]							

Chip ID LSB [7:0]

This register identifies the LSB of device ID. This value equals 58h for TVP5158, 57h for TVP5157, and 56h for TVP5156.

**Table 4-10. Video Standard Status**

**Subaddress**        0Ch  
**Default**            Read only

7	6	5	4	3	2	1	0
Autoswitch	Reserved				Video standard [2:0]		

This register contains information about the detected video standard that the device is currently operating. When in autoswitch mode, this register can be tested to determine which video standard as has been detected. See subaddress: 0Dh.

**Autoswitch Mode**

- 0     Single standard set
- 1     Autoswitch mode enabled

**Video Standard [2:0]**

- 00h   Reserved
- 01h   (M, J) NTSC
- 02h   (B, D, G, H, I, N) PAL
- 03h   (M) PAL
- 04h   (Combination-N) PAL
- 05h   NTSC 4.43
- 06h   Reserved
- 07h   PAL 60

**Table 4-11. Video Standard Select**

**Subaddress**        0Dh  
**Default**            00h

7	6	5	4	3	2	1	0
Reserved					CVBS Standard [2:0]		

The user can force the device to operate in a particular video standard mode by writing the appropriate value into this register. Changing these bits causes some register settings to be reset to their defaults. See subaddress: 0Ch.

**CVBS Standard [2:0]**

- 00h   CVBS Autoswitch mode (default)
- 01h   (M, J) NTSC
- 02h   (B, D, G, H, I, N) PAL
- 03h   (M) PAL
- 04h   (Combination-N) PAL
- 05h   NTSC 4.43
- 06h   Reserved
- 07h   PAL 60



**Table 4-12. CVBS Autoswitch Mask**

**Subaddress** 0Eh  
**Default** 03h

7	6	5	4	3	2	1	0
Reserved	PAL 60	Reserved	NTSC 4.43	(Nc) PAL	(M) PAL	PAL	(M, J) NTSC

**Autoswitch mode mask**

Limits the video formats between which autoswitch is possible.

PAL 60	0	Autoswitch does not include PAL 60 (default)
	1	Autoswitch includes PAL 60
NTSC 4.43	0	Autoswitch does not include NTSC 4.43 (default)
	1	Autoswitch includes NTSC 4.43
(Nc) PAL	0	Autoswitch does not include (Nc) PAL (default)
	1	Autoswitch includes (Nc) PAL
(M) PAL	0	Autoswitch does not include (M) PAL (default)
	1	Autoswitch includes (M) PAL
PAL	0	Reserved
	1	Autoswitch includes (B, D, G, H, I, N) PAL (default)
(M, J) NTSC	0	Reserved
	1	Autoswitch includes (M, J) NTSC (default)

**Table 4-13. Auto Contrast Mode**

**Subaddress** 0Fh  
**Default** 03h

7	6	5	4	3	2	1	0
Reserved						Auto Contrast Mode [1:0]	

**Auto Contrast Mode [1:0]**

00h	Enabled
01h	Reserved
02h	User Mode
03h	Disabled (default)

**Table 4-14. Luminance Brightness**

**Subaddress** 10h  
**Default** 80h

7	6	5	4	3	2	1	0
Brightness [7:0]							

**Brightness [7:0]**

This register works for the luminance. See subaddress 12h.

0000 0000	0 (dark)
1000 0000	128 (default)
1111 1111	255 (bright)

The output black level relative to the nominal black level (64 out of 1024) as a function of the Brightness[7:0] setting is as follows:

$$\text{Black Level} = \text{nominal\_black\_level} + (M_B + 1) \times (\text{Brightness}[7:0] - 128)$$

Where  $M_B$  is the brightness multiplier setting in the Brightness and Contrast Range Extender register at I<sup>2</sup>C subaddress 12h.

**Table 4-15. Luminance Contrast**

**Subaddress** 11h  
**Default** 80h

7	6	5	4	3	2	1	0
Contrast [7:0]							

**Contrast [7:0]**

This register works for the luminance. See subaddress 12h.

0000 0000 0 (minimum contrast)

1000 0000 128 (default)

1111 1111 255 (maximum contrast)

The total luminance gain relative to the nominal luminance gain as a function of the Contrast [7:0] setting is as follows:

$$\text{Luminance Gain} = (\text{nominal\_luminance\_gain}) \times [\text{Contrast}[7:0] / 64 / (2^{M_C} + M_C - 1)]$$

Where  $M_C$  is the contrast multiplier setting in the Brightness and Contrast Range Extender register at I<sup>2</sup>C subaddress 12h.

**Table 4-16. Brightness and Contrast Range Extender**

**Subaddress** 12h  
**Default** 00h

7	6	5	4	3	2	1	0
Reserved			Contrast multiplier	Brightness multiplier [3:0]			

**Contrast multiplier [4] ( $M_C$ )**

Increases the contrast control range.

0 2x contrast control range (default), Gain =  $n/64 - 1$  where  $n$  is the contrast control and  $64 \leq n \leq 255$

1 Normal contrast control range, Gain =  $n/128$  where  $n$  is the contrast control and  $0 \leq n \leq 255$

**Brightness multiplier [3:0] ( $M_B$ )**

Increases the brightness control range from 1x to 16x.

0h 1x (default)

1h 2x

3h 4x

7h 8x

Fh 16x

NOTE: The brightness multiplier should be set to 3h for 8-bit outputs.

**Table 4-17. Chrominance Saturation**

**Subaddress** 13h  
**Default** 80h

7	6	5	4	3	2	1	0
Saturation [7:0]							

**Saturation [7:0]**

This register works for the chrominance.

0000 0000 0 (no color)

1000 0000 128 (default)

1111 1111 255 (maximum)

The total chrominance gain relative to the nominal chrominance gain as a function of the Saturation [7:0] setting is as follows:

$$\text{Chrominance Gain} = (\text{nominal\_chrominance\_gain}) \times (\text{Saturation}[7:0] / 128)$$

**Table 4-18. Chrominance Hue**

**Subaddress** 14h  
**Default** 80h

7	6	5	4	3	2	1	0
Hue [7:0]							

Saturation [7:0]

This register works for the chrominance.

0000 0000 -180°

1000 0000 0° (default)

1111 1111 +180°

**Table 4-19. Color Killer**

**Subaddress** 16h  
**Default** 10h

7	6	5	4	3	2	1	0
Reserved	Automatic color killer		Color killer threshold [4:0]				

Automatic color killer

00 Automatic mode (default)

01 Reserved

10 Color killer enabled, The UV terminals are forced to a zero color state.

11 Color killer disabled

Color killer threshold [4:0]:

Controls the upper and lower color killer hysteresis thresholds.

	NTSC-M,J <sup>(1)(2)</sup>		PAL-B,D,G,H,I,M,N <sup>(1)(2)</sup>	
	Lower Threshold	Upper Threshold	Lower Threshold	Upper Threshold
0 0000	1.0%	1.4%	0.8%	1.2%
0 1000	3.0%	4.3%	2.4%	3.5%
1 0000	5.0%	7.2%	4.0%	5.8%
1 1000	7.0%	10.0%	5.6%	8.0%
1 1111	8.8%	12.6%	7.0%	10.0%

(1) Expressed as a percent of the nominal color burst amplitude (measured after front-end AGC).

(2) For proper color killer operation, the color PLL must be locked to the color burst frequency.

**Table 4-20. Luminance Processing Control 1**

**Subaddress** 18h  
**Default** 40h

7	6	5	4	3	2	1	0
NTSC_Ped	Reserved			Luminance signal delay [2:0]			

**NTSC\_Ped**

Specifies whether NTSC composite video inputs are compliant with NTSC-M or NTSC-J.

- 0 NTSC-M (714/286 ratio, w/ pedestal) - default
- 1 NTSC-J (714/286 ratio, w/o pedestal)

**Luminance signal delay [2:0]**

Luminance signal delays respect to chroma signal in 1x pixel clock increments.

- 011 3 pixel clocks delay
- 010 2 pixel clocks delay
- 001 1 pixel clocks delay
- 000 0 pixel clocks delay (default)
- 111 -1 pixel clocks delay
- 110 -2 pixel clocks delay
- 101 -3 pixel clocks delay
- 100 0 pixel clocks delay

**Table 4-21. Luminance Processing Control 2**

**Subaddress** 19h  
**Default** 00h

7	6	5	4	3	2	1	0
Luma filter select [1:0]		Reserved		Peaking gain [1:0]		Trap filter select [1:0]	

**Luma filter selected [1:0]**

- 00 Luminance adaptive comb enable (default)
- 01 Luminance adaptive comb disable (trap filter selected)
- 10 Luma comb/trap filter bypassed
- 11 Reserved

**Peaking gain [1:0]**

- 00 0 (default)
- 01 0.5
- 10 1
- 11 2

**Trap filter select [1:0]**

Selects one of the four trap filters to produce the luminance signal by removing the chrominance signal from the composite video signal. The stop band of the chroma trap filter is centered at the chroma subcarrier frequency with the stop-band bandwidth controlled by the two control bits.

**Trap filter stop-band bandwidth (MHz)**

Filter select [1:0]	NTSC ITU-R BT.601	PAL ITU-R BT.601
00 = (default)	1.2129	1.2129
01	0.8701	0.8701
10	0.7183	0.7383
11	0.5010	0.5010

**Table 4-22. Power Control**

**Subaddress**      1Ah  
**Default**          00h

7	6	5	4	3	2	1	0
Pwd_ach4	Pwd_ach3	Pwd_ach2	Pwd_ach1	Pwd_vpll	Pwd_ref	Pwd_ofm_clk	Pwd_video

**Pwd\_ach4**

Power down audio channel 4, active high

0 Normal operation (default)

1 Audio channel 4 power down

**Pwd\_ach3**

Power down audio channel 3, active high

0 Normal operation (default)

1 Audio channel 3 power down

**Pwd\_ach2**

Power down audio channel 2, active high

0 Normal operation (default)

1 Audio channel 2 power down

**Pwd\_ach1**

Power down audio channel 1, active high

0 Normal operation (default)

1 Audio channel 1 power down

**Pwd\_vpll**

Power down video PLL, active high

0 Normal operation (default)

1 Video PLL power down

**Pwd\_ref**

Power down bandgap reference, active high

0 Normal operation (default)

1 Bandgap reference power down

**Pwd\_ofm\_clk**

Power down OFM clock, active high

0 Normal operation (default)

1 OFM clock power down

**Pwd\_video**

Power down video channel corresponding to current decoder core, active high

0 Normal operation (default)

1 Power down video channel corresponding to current decoder core

**Table 4-23. Chrominance Processing Control 1**

**Subaddress**      1Bh  
**Default**          00h

7	6	5	4	3	2	1	0
Reserved			Color PLL reset	Chroma adaptive comb enable	Reserved	Automatic color gain control [1:0]	

**Color PLL reset**

- 0      Color subcarrier PLL not reset (default)
- 1      Color subcarrier PLL reset

**Chrominance adaptive comb enable**

This bit is effective on composite video only.

- 0      Enabled (default)
- 1      Disabled

**Automatic color gain control (ACGC) [1:0]**

- 00     ACGC enabled (default)
- 01     Reserved
- 10     ACGC disabled, ACGC set to the nominal value
- 11     ACGC frozen to the previously set value

**Table 4-24. Chrominance Processing Control 2**

**Subaddress**      1Ch  
**Default**          0Ch

7	6	5	4	3	2	1	0
Reserved				PAL compensation	WCF	Chrominance filter select [1:0]	

**PAL compensation**

This bit is not effective to NTSC mode.

- 0      Disabled
- 1      Enabled (default)

**Wideband chroma LPF filter (WCF)**

- 0      Disabled
- 1      Enabled (default)

**Chrominance filter select [1:0]**

This register trades chroma bandwidth for less false color.

- 00     Disabled (default)
- 01     Notch 1
- 10     Notch 2
- 11     Notch 3

**Table 4-25. AGC Gain Status**

**Subaddress** 20h-21h  
**Default** Read Only

Subaddress	7	6	5	4	3	2	1	0
20h	Fine Gain [7:0]							
21h	Reserved			Fine Gain [13:8]				

These AGC gain status registers are updated automatically when the AGC is enabled; in manual gain control mode these register values are not updated.

Because this register is a multi-byte register, it is necessary to "capture" the setting into the register to ensure that the value is not updated between reading the lower and upper bytes. To cause this register to "capture" the current settings bit 0 of I<sup>2</sup>C register 24h (Status Request) should be set to a 1. After the internal processor has updated this register, bit 0 of register 24h is cleared, indicating that both bytes of the AGC gain status register have been updated and can be read. Either byte may be read first, because no further update occurs until bit 0 of 24h is set to 1 again.

**Table 4-26. Back-End AGC Status**

**Subaddress** 23h  
**Default** Read Only

7	6	5	4	3	2	1	0
Gain [7:0]							

Current back-end AGC ratio = Gain/128.

**Table 4-27. Status Request**

**Subaddress** 24h  
**Default** 00h

7	6	5	4	3	2	1	0
Reserved							Capture

Capture

Setting a 1 in this register causes the inter processor to capture the current settings of the AGC status, noise measurement, and the vertical line count registers. Because this capture is not immediate, it is necessary to check for completion of the capture by reading the "capture" bit repeatedly after setting it and waiting for it to be cleared by the internal processor. After the "capture" bit is 0, the AGC status, noise measurement, and vertical line counters (20h/21h, 94h/95h, and A2h/A3h) have been updated, and can be safely read in any order.

**Table 4-28. AFE Gain Control**

**Subaddress** 25h  
**Default** F5h

7	6	5	4	3	2	1	0
Reserved					ALC	Reserved	AGC

Reserved

For future compatibility, all reserved bits must be set to logic 1.

ALC

Active-high automatic level control (ALC) enable

0 ALC disabled (manual level control)

1 ALC enabled (default)

AGC

Active-high automatic gain control (AGC) enable

0 AGC disabled (manual gain control)

1 AGC enabled (default)

**Table 4-29. Luma ALC Freeze Upper Threshold**

**Subaddress**      26h  
**Default**          00h

7	6	5	4	3	2	1	0
Luma ALC freeze [7:0]							

Upper hysteresis threshold for luma ALC freeze function. The lower hysteresis threshold for the ALC freeze function is fixed at 1 count out of 4096. Setting the upper threshold to 00h (default condition) disables the ALC freeze function.

**Table 4-30. Chroma ALC Freeze Upper Threshold**

**Subaddress**      27h  
**Default**          00h

7	6	5	4	3	2	1	0
Chroma ALC freeze [7:0]							

Upper hysteresis threshold for chroma ALC freeze function. The lower hysteresis threshold for the ALC freeze function is fixed at 1 count out of 4096. Setting the upper threshold to 00h (default condition) disables the ALC freeze function. Recommend a setting of 02h or greater when enabled.

**Table 4-31. AGC Increment Speed**

**Subaddress**      29h  
**Default**          06h

7	6	5	4	3	2	1	0
Reserved				AGC increment speed [3:0]			

AGC increment speed

Controls the filter coefficient of the first-order, recursive automatic gain control (AGC) algorithm whenever incrementing the gain.

000	0 (fastest)
110	6 (default)
111	7 (slowest)

**Table 4-32. AGC Increment Delay**

**Subaddress**      2Ah  
**Default**          1Eh

7	6	5	4	3	2	1	0
AGC increment delay [7:0]							

AGC increment delay [7:0]

Number of frames to delay gain increments. Also see AGC decrement delay at subaddress 2Ch.

00000000	0
00011110	30 frames (default)
11111111	255 frames



**Table 4-33. AGC Decrement Speed**

**Subaddress**      2Bh  
**Default**          04h

7	6	5	4	3	2	1	0
Reserved					AGC decrement speed [2:0]		

**AGC decrement speed**

Controls the filter coefficient of the first-order recursive automatic gain control (AGC) algorithm when decrementing the gain.  
NOTE: This register affects the decrement speed only when the amplitude reference used by the AGC is either the composite peak or the luma peak.

Also see AGC increment speed at subaddress 29h.

111    7 (slowest)  
110    6 (default)  
000    0 (fastest)

**Table 4-34. AGC Decrement Delay**

**Subaddress**      2Ch  
**Default**          00h

7	6	5	4	3	2	1	0
AGC decrement delay [7:0]							

**AGC decrement delay [7:0]**

Number of frames to delay gain decrements.

NOTE: This register affects the decrement delay only when the amplitude reference used by the AGC is either the composite peak or the luma peak.

Also see AGC increment delay at subaddress 2Ah.

111    0  
110    30 (default)  
000    255

**Table 4-35. AGC White Peak Processing**

**Subaddress**        2Dh  
**Default**            F2h

7	6	5	4	3	2	1	0
Luma peak A	Reserved	Color burst A	Sync height A	Luma peak B	Composite peak	Color burst B	Sync height B

If all four bits of the lower nibble are set to logic 1 (that is, no amplitude reference selected), then the front-end analog and digital gains are automatically set to nominal values.

If all four bits of the upper nibble are set to logic 1 (that is, no amplitude reference selected), then the back-end gain is set automatically to unity. If the input sync height is greater than 100% and the AGC-adjusted output video amplitude becomes less than 100%, then the back-end scale factor attempts to increase the contrast in the back-end to restore the video amplitude to 100%.

**Luma peak A**

Use of the luma peak as a video amplitude reference for the back-end feed-forward type AGC algorithm

0      Enabled (default)  
 1      Disabled

**Color burst A**

Use of the color burst amplitude as a video amplitude reference for the back-end

0      Enabled (default)  
 1      Disabled

**Sync height A**

Use of the sync-height as a video amplitude reference for the back-end feed-forward type AGC algorithm

0      Enabled (default)  
 1      Disabled

**Luma peak B**

Use of the luma peak as a video amplitude reference for front-end feedback type AGC algorithm

0      Enabled (default)  
 1      Disabled

**Composite peak**

Use of the composite peak as a video amplitude reference for front-end feedback type AGC algorithm

0      Enabled (default)  
 1      Disabled

**Color burst B**

Use of the color burst amplitude as a video amplitude reference for front-end feedback type AGC algorithm

0      Enabled (default)  
 1      Disabled

**Sync height B**

Use of the sync-height as a video amplitude reference for front-end feedback type AGC algorithm

0      Enabled (default)  
 1      Disabled

**Table 4-36. Back-End AGC Control**

**Subaddress**      2Eh  
**Default**          08h

7	6	5	4	3	2	1	0
Reserved				1	Peak	Color	Sync

This register allows disabling the back-end AGC when the front-end AGC uses specific amplitude references (sync-height, color burst or composite peak) to decrement the front-end gain. For example, writing 09h to this register disables the back-end AGC whenever the front-end AGC uses the sync-height to decrement the front-end gain.

**Peak**

Disables back-end AGC when the front-end AGC uses the composite peak as an amplitude reference.

0      Enabled (default)  
1      Disabled

**Color**

Disables back-end AGC when the front-end AGC uses the color burst as an amplitude reference.

0      Enabled (default)  
1      Disabled

**Sync**

Disables back-end AGC when the front-end AGC uses the sync height as an amplitude reference.

0      Enabled (default)  
1      Disabled

**Table 4-37. AFE Fine Gain**

**Subaddress**      34h-35h  
**Default**          086Ah

Subaddress	7	6	5	4	3	2	1	0
34h	FGAIN [7:0]							
35h	Reserved		FGAIN [13:8]					

**FGAIN [13:0]**

This fine gain applies to CVBS. Fine Gain =  $(1/2048) \times \text{FGAIN}$  where  $0 \leq \text{FGAIN} \leq 16383$ . This register works only in manual gain control mode. When AGC is active, writing to any value is ignored.

00 0000 0000 0000 to 00 0011 1111 1111	Reserved
00 0100 0000 0000	0.5
00 1000 0000 0000	1
00 1000 0110 1010	1.052 (default)
00 1100 0000 0000	1.5
11 1111 1111 1111	7.9995

**Table 4-38. AVID Start Pixel**

**Subaddress** 48h-49h  
**Default** 007Ah/0084h

Subaddress	7	6	5	4	3	2	1	0
48h	AVID start [7:0]							
49h	Reserved			AVID active	Reserved		AVID start [9:8]	

**AVID start [9:0]**

AVID start pixel number, this is a absolute pixel location from HS start pixel 0.

The TVP5158 updates the AVID start only when the AVID start MSB byte is written to. AVID start pixel register also controls the position of SAV code. If these registers are modified, then the TVP5158 retains the values for each video standard until the device is reset. The values for a particular video standard should be set by forcing the TVP5158 to the desired video standard first using register 0Dh then setting this register. This should be repeated for each video standard where the default values need to be changed.

**AVID active**

0 AVID out active in VBLK (default)  
 1 AVID out inactive in VBLK

**Table 4-39. AVID Pixel Width**

**Subaddress** 4Ah-4Bh  
**Default** 02D0h

Subaddress	7	6	5	4	3	2	1	0
4Ah	AVID Width [7:0]							
4Bh	Reserved						AVID Width [9:8]	

**AVID Width [9:0]**

AVID pixel width. The number of pixels width of active video must be an even number. This is an absolute pixel location from HS start pixel 0.

The TVP5158 updates the AVID pixel width only when the AVID pixel width MSB byte is written to. AVID Pixel Width register also controls the position of EAV code. If these registers are modified, then the TVP5158 retains the values for each video standard until the device is reset. The values for a particular video standard should be set by forcing the TVP5158 to the desired video standard first using register 0Dh then setting this register. This should be repeated for each video standard where the default values need to be changed.

**Table 4-40. Noise Reduction Max Noise**

**Subaddress** 5Ch  
**Default** 28h

7	6	5	4	3	2	1	0
Reserved	NR_Max_Noise [6:0]						

**NR\_Max\_Noise [6:0]**

User-defined maximum noise level  
 0010 1000 40 (default)

**Table 4-41. Noise Reduction Control**

**Subaddress** 5Dh  
**Default** 09h

7	6	5	4	3	2	1	0
Reserved			NR_Color_Killer_En	Block_Width_UV	Block_Width_Y	Test_Bypass	NR_Bypass

**NR\_Color\_Killer\_En**

Noise reduction color killer enabled

0 Disabled (default)  
1 Enabled

**Block\_Width\_UV**

Number of UV pixel values which the algorithm uses to generate the noise average.

0 128 pixels  
1 256 pixels (default)

**Block\_Width\_Y**

Number of Y pixel values which the algorithm uses to generate the noise average.

0 256 pixels (default)  
1 512 pixels

**Test\_Bypass**

Test mode bypass. This test bypass mode bypasses the Noise Reduction module completely via hard wires and has zero delay for processing.

0 Bypass disabled (default)  
1 Bypass enabled

**NR\_Bypass**

Noise reduction module bypass. The noise reduction module has a bypass capability which enables it to pass through the incoming data during the output active video period, while matching the delay in operation mode.

0 Bypass disabled  
1 Bypass enabled (default)

**Table 4-42. Noise Reduction Noise Filter Beta**

**Subaddress** 5Eh-5Fh  
**Default** 0330h

Subaddress	7	6	5	4	3	2	1	0
5Eh	NR_NoiseFilter [7:0]							
5Fh	Reserved						NR_NoiseFilter [9:8]	

**NR\_NoiseFilter [9:0]**

Noise reduction noise filter setting

0000 0011 0011 0000 816 (default)

**Table 4-43. Operation Mode Control**

**Subaddress**        60h  
**Default**            00h

7	6	5	4	3	2	1	0
V-PLL free run	Reserved	H-PLL Response Time		V-bit control	Freeze C-PLL	Reserved	

V-PLL free run mode

- 0     Disabled (default)
- 1     Enabled

H-PLL Response Time

When in the Normal mode, the horizontal PLL (H-PLL) response time is set to its slowest setting. This mode improves noise immunity and provides a more stable output line frequency for standard TV signal sources (for example, TV tuners, DVD players, video surveillance cameras, etc.).

When in the Fast mode, the H-PLL response time is set to its fastest setting. This mode enables the H-PLL to respond more quickly to large variations in the horizontal timing (for example, VCR head switching intervals). This mode is recommended for VCRs and also cameras locked to the AC power-line frequency.

When in the Adaptive mode, the H-PLL response time is automatically adjusted based on the measured horizontal phase error. In this mode, the H-PLL response time typically approaches its slowest setting for most standard TV signal sources and approaches its fastest setting for most VCR signal sources.

- 00    Adaptive (default)
- 01    Reserved
- 10    Fast
- 11    Normal

V-bit control mode

- 0     Vertical blanking interval remains constant as total number of lines per frame varies (default)
- 1     Active video interval remains constant as total number of lines per frame varies

Freeze C-PLL

- 0     Normal operation (default)
- 1     Freeze color PLL

**Table 4-44. Color PLL Speed Control**

**Subaddress**        61h  
**Default**            09h

7	6	5	4	3	2	1	0
Reserved				CPLL speed [3:0]			

CPLL speed [3:0]

Color PLL speed control

- 0000 to 1000     Reserved
- 1001     9: Faster (default)
- 1010     10
- 1011     11: Slower
- 1100 to 1111     Reserved

**Table 4-45. Sync Height Low Threshold**

**Subaddress** 7Ch  
**Default** 02h

7	6	5	4	3	2	1	0
VSync upper thres [7:0]							

Lower hysteresis threshold for vertical sync-height detection (value/32×target sync height).

**Table 4-46. Sync Height High Threshold**

**Subaddress** 7Dh  
**Default** 08h

7	6	5	4	3	2	1	0
VSync upper thres [7:0]							

Upper hysteresis threshold for vertical sync-height detection (value/32×target sync height).

**Table 4-47. Clear Lost Lock Detect**

**Subaddress** 81h  
**Default** 00h

7	6	5	4	3	2	1	0
Reserved							Clear lost lock detect

Clear lost lock detect

Clear bit 4 (lost lock detect) in the status 1 register at subaddress 00h

0 No effect (default)

1 Clears bit 4 in the status 1 register (00h)

**Table 4-48. VSYNC Filter Shift**

**Subaddress** 85h  
**Default** 03h

7	6	5	4	3	2	1	0
Reserved						VSYNC filter shift [1:0]	

VSYNC filter shift [1:0]

Used for adaptation of VPLL time constant

00 0 (fast)

01 1

10 2

11 3 (slow)

**Table 4-49. 656 Version/F-bit Control**

**Subaddress**        87h  
**Default**            00h

7	6	5	4	3	2	1	0
Reserved						656 version	F-control

**656 version**

- 0    Timing confirms to ITU-R BT.656-4 specifications (default)
- 1    Timing confirms to ITU-R BT.656-3 specifications

**F-control**

- 0    Odd field causes 0 → 1 transition in F-bit when in TVP5146 F/V mode (see register 88h)
- 1    Even field causes 0 → 1 transition in F-bit when in TVP5146 F/V mode (see register 88h)



**Table 4-50. F-Bit and V-Bit Decode Control**

**Subaddress**        88h  
**Default**            03h

7	6	5	4	3	2	1	0
Reserved			VPLL	Adaptive	Reserved	F-Mode [1:0]	

**VPLL**

VPLL time constant control

0      VPLL adapts time constants to input signal

1      VPLL time constants fixed

**Adaptive**

0      Enable F and V bit adaptation to detected lines per frame

1      Disable F and V bit adaptation to detected lines per frame

**F-Mode [1:0]**

F-bit control mode

00     Auto: If lines per frame is standard decode F and V bits as per 656 standard from line count else decode F bit from VSYNC input and set V bit = 0

01     Decode F and V from input syncs

10     Reserved

11     Always decode F and V bits from line count (TVP5146 compatible)

This register is used in conjunction with register 89h as shown:

Reg 88h		Reg 89h		Mode	Standard LPF		Non-standard LPF	
Bit 1	Bit 0	Bit 3	Bit 2		F	V	F	V
0	0	0	0	Reserved	Reserved	Reserved	Reserved	Reserved
0	0	0	1	TVP5158	656	656	Toggle	Switch9
0	0	1	0	TVP5158	656	656	Pulse	0
0	0	1	1	Reserved	Reserved	Reserved	Reserved	Reserved
0	1	0	0	Reserved	Reserved	Reserved	Reserved	Reserved
0	1	0	1		656	656	Toggle	Switch9
0	1	1	0		656	656	Pulse	0
0	1	1	1	Reserved	Reserved	Reserved	Reserved	Reserved
1	0	0	0	Reserved	Reserved	Reserved	Reserved	Reserved
1	0	0	1	Reserved	Reserved	Reserved	Reserved	Reserved
1	0	1	0	Reserved	Reserved	Reserved	Reserved	Reserved
1	0	1	1	Reserved	Reserved	Reserved	Reserved	Reserved
1	1	0	0	TVP5146	656	656	Even = 1 Odd = toggle	Switch
1	1	0	1	TVP5146	656	656	Toggle	Switch
1	1	1	0	TVP5146	656	656	Pulse	Switch
1	1	1	1	Reserved	Reserved	Reserved	Reserved	Reserved

656      ITU-R BT.656 standard

Toggle    Toggles from field to field

Pulse     Pulses low for 1 line prior to field transition

Switch    V bit switches high before the F bit transition and low after the F bit transition

Switch9   V bit switches high 1 line prior to F bit transition, then low after 9 lines

Reserved   Not used

**Table 4-51. F-Bit and V-Bit Control**

**Subaddress**        89h  
**Default**            16h

7	6	5	4	3	2	1	0
Rabbit	Reserved		Fast lock	F and V [1:0]		Phase Det	HPLL

**Rabbit**

Enable "rabbit ear"

0     Disabled (default)

1     Enabled

**Fast lock**

Enable fast lock where vertical PLL is reset and a 2 second timer is initialized when vertical lock is lost; during timeout the detected input VS is output.

0     Disabled

1     Enabled (default)

**F and V [1:0]**

F and V control bits are only enabled for F-bit control mode 01 and 10 (see register 88h)

F and V	Lines Per Frame	F Bit	V Bit
00	Standard	ITU-R BT.656	ITU-R BT.656
	Non standard-even	Forced to 1	Switch at field boundary
	Non standard-odd	Toggles	Switch at field boundary
01 (default)	Standard	ITU-R BT.656	ITU-R BT.656
	Non standard	Toggles	Switch at field boundary
10	Standard	ITU-R BT.656	ITU-R BT.656
	Non standard	Pulsed mode	Switch at field boundary
11	Reserved		

**Phase Det**

Enable integral-window phase detector

0     Disabled

1     Enabled (default)

**HPLL**

Enable horizontal PLL to free run

0     Disabled (default)

1     Enabled

**Table 4-52. Output Timing Delay**

**Subaddress**        8Ch  
**Default**            00h

7	6	5	4	3	2	1	0
Output timing delay [7:0]							

**Output timing delay [7:0]**

Adjusts delay for AVID start and stop.

0000 1111     +15 pixel delay

0000 0001     +1 pixel delay

0000 0000     0 pixel delay (default)

1111 1111     -1 pixel delay

1111 0000     -16 pixel delay

**Table 4-53. Auto Contrast User Table Index**

**Subaddress**      8Fh  
**Default**         04h

7	6	5	4	3	2	1	0
Reserved	AC_User_Mode_Table [2:0]			Reserved			

AC\_User\_Mode\_Table [2:0]

User table selection for auto contrast user mode when the register 0Fh sets to 02h.

000	Brighter 1
001	Brighter 2
010	Brighter 3 (Brightest)
011	Darker 1
100	Darker 2
101	Darker 3 (Darkest)
110 to 111	Reserved

**Table 4-54. Blue Screen Y Control**

**Subaddress**      90h  
**Default**         10h

7	6	5	4	3	2	1	0
Y value [9:2]							

The Y value of the color screen output when enabled by bit 2 or 3 of the Output Formatter 2 register is programmable using a 10-bit value. The 8 MSBs, bits [9:2], are represented in this register. The remaining two LSB are found in the Blue Screen LSB register. The default color screen output is black.

The following table shows the values for registers 90h, 91h, 92h and 93h for several different screen colors.

Screen Color	Reg 90h	Reg 91h	Reg 92h	Reg 93h
Black (default)	10h	80h	80h	00h
Blue	29h	F0h	6Eh	00h
Green	91h	36h	22h	00h
Cyan	AAh	A6h	10h	00h
Red	51h	5Ah	F0h	00h
Magenta	6Ah	CAh	DEh	00h
Yellow	D2h	10h	92h	00h
White	EBh	80h	80h	00h

NOTE: The blue screen output mode can be enabled or disabled using bits 3:2 of I<sup>2</sup>C register A9h.

**Table 4-55. Blue Screen Cb Control**

**Subaddress**      91h  
**Default**         80h

7	6	5	4	3	2	1	0
Cb value [9:2]							

The Cb value of the color screen output when enabled by bit 2 or 3 of the Output Formatter 2 register is programmable using a 10-bit value. The 8 MSBs, bits [9:2], are represented in this register. The remaining two LSB are found in the Blue screen LSB register. The default color screen output is black. See [Table 4-54](#) for example colors.

**Table 4-56. Blue Screen Cr Control**

**Subaddress** 92h  
**Default** 80h

7	6	5	4	3	2	1	0
Cr value [9:2]							

The Cr value of the color screen output when enabled by bit 2 or 3 of the Output Formatter 2 register is programmable using a 10-bit value. The 8 MSBs, bits[9:2], are represented in this register. The remaining two LSB are found in the Blue Screen LSB register. The default color screen output is black. See [Table 4-54](#) for example colors.

**Table 4-57. Blue Screen LSB Control**

**Subaddress** 93h  
**Default** 00h

7	6	5	4	3	2	1	0
Reserved		Y value LSB [1:0]		Cb value LSB [1:0]		Cr value LSB [1:0]	

The two LSBs for the Blue screen Y, Cb, and Cr values are represented in this register. See [Table 4-54](#) for example colors.

**Table 4-58. Noise Measurement**

**Subaddress** 94h-95h  
**Default** Read Only

Subaddress	7	6	5	4	3	2	1	0
94h	Noise Measurement [7:0]							
95h	Noise Measurement [15:8]							

Noise measurement [15:0]

Used by the weak signal detection algorithm.

Because this register is a double-byte register, it is necessary to "capture" the setting into the register to ensure that the value is not updated between reading the lower and upper bytes. To cause this register to "capture" the current settings bit 0 of I<sup>2</sup>C register 24h (status request) should be set to a 1. After the internal processor has updated this register, bit 0 of register 24h is cleared, indicating that both bytes of the noise measurement register have been updated and can be read. Either byte may be read first, because no further update occurs until bit 0 of 24h is set to 1 again.

**Table 4-59. Weak Signal High Threshold**

**Subaddress** 96h  
**Default** 60h

7	6	5	4	3	2	1	0
Level [7:0]							

This register controls the upper threshold of the noise measurement used to determine whether the input signal should be considered a weak signal.

**Table 4-60. Weak Signal Low Threshold**

**Subaddress** 97h  
**Default** 50h

7	6	5	4	3	2	1	0
Level [7:0]							

This register controls the lower threshold of the noise measurement used to determine whether the input signal should be considered a weak signal.

**Table 4-61. Noise Reduction Y/U/V T0**

<b>Subaddress</b>	9Eh	9Fh	A0h					
<b>Default</b>	0Ah	BCh	BCh					
Subaddress	7	6	5	4	3	2	1	0
9Eh	Noise Reduction Y T0 [7:0]							
9Fh	Noise Reduction U T0 [7:0]							
A0h	Noise Reduction V T0 [7:0]							

These registers control how much noise filtering is done for Y/U/V channels. The higher the value is, the more noise filtering at the expense of video details.

**Table 4-62. Vertical Line Count Status**

**Subaddress** A2h-A3h  
**Default** Read Only

Subaddress	7	6	5	4	3	2	1	0
A2h	Vertical line [7:0]							
A3h	Reserved						Vertical line [9:8]	

This status register is only updated when a status request is initiated via bit 0 of subaddress 24h.

Vertical line [9:0] represent the detected a total number of lines from the previous frame. This can be used with nonstandard video signals such as a VCR in trick mode to synchronize downstream video circuitry.

NOTE: This register is not double buffered.

Because this register is a double-byte register, it is necessary to "capture" the setting into the register to ensure that the value is not updated between reading the lower and upper bytes. To cause this register to "capture" the current settings bit 0 of I<sup>2</sup>C register 24h (Status Request) should be set to a 1. After the internal processor has updated this register, bit 0 of register 24h is cleared, indicating that both bytes of the vertical line count register have been updated and can be read. Either byte may be read first, because no further update occurs until bit 0 of 24h is set to 1 again.

**Table 4-63. Output Formatter Control 1**

**Subaddress** A8h  
**Default** 44h

7	6	5	4	3	2	1	0
Reserved	YCbCr code range	CbCr range	Reserved				

This register should be written to all four video decoder cores.

YCbCr output code range

- 0 ITU-R BT.601 coding range (Y ranges from 16 to 235. Cb and Cr range from 16 to 240.)
- 1 Extended coding range (Y, Cb and Cr range from 1 to 254.) (default)

CbCr range format

- 0 Offset binary code (2's complement + 512) (default)
- 1 Straight binary code (2's complement)

**Table 4-64. Output Formatter Control 2**

**Subaddress**      A9h  
**Default**          40h

7	6	5	4	3	2	1	0
Reserved				Blue screen output [1:0]		Reserved	

This register should be written to all four video decoder cores.

**Blue screen output [1:0]**

Fully programmable color of "blue screen" to support clean input/channel switching. When enabled, in case of lost lock, or when forced, the TVP5158 waits until the end of the current frame, then switches the output data to a programmable color. Once displaying the "blue screen", the inputs can be switched without causing snow or noise to be displayed on the digital output data. Once the inputs have settled the "blue screen" can be disabled, where the TVP5158 then waits until the end of the current video frame before re-enabling the video stream data to the output ports.

00	Normal operation (default)
01	Blue screen out when TVP5158 detects lost lock
10	Force Blue screen out
11	Reserved

**Table 4-65. Interrupt Control**

**Subaddress**      ADh  
**Default**          00h

7	6	5	4	3	2	1	0
Int_Pol	Int_Type	Reserved					

**Int\_Pol**

Interrupt polarity

0	Active low (default)
1	Active high (do not use with open-drain output)

NOTE: Active-high output should be used only when push-pull output type is selected (Int\_Type = 1).

**Int\_Type**

Interrupt output type

0	Open-drain output (default)
1	Push-pull output

NOTE: An external pullup resistor is required when open drain output is selected (Int Type = 0).

**Table 4-66. Embedded Sync Offset Control 1**

**Subaddress**      AEh  
**Default**          01h

7	6	5	4	3	2	1	0
Offset [7:0]							

**Offset [7:0]**

This register allows the line position of the embedded F and V bit signals to be offset from the 656 standard positions. This register is only applicable to input video signals with a standard number of lines per frame.

01111111	+127 lines
⋮	
00000001	+1 line (default)
00000000	0 line
11111111	-1 line
⋮	
10000000	-128 lines

**Table 4-67. Embedded Sync Offset Control 2**

<b>Subaddress</b>	AFh						
<b>Default</b>	00h						
7	6	5	4	3	2	1	0
Offset [7:0]							

**Offset [7:0]**

This register allows the line relationship between the embedded F and V bit signals to be offset from the 656 standard positions, and moves F relative to V. This register is only applicable to input video signals with a standard number of lines per frame.

0000 0010	+2 lines (maximum setting for NTSC and PAL)
⋮	
0000 0001	+1 line
0000 0000	0 line
1111 1111	-1 line
⋮	
1111 0001	-15 lines (minimum setting for NTSC)
⋮	
1110 1011	-21 lines (minimum setting for PAL)

**Table 4-68. AVD Output Control 1**

**Subaddress**        B0h  
**Default**            00h

7	6	5	4	3	2	1	0
Interleave_mode		Channel_Mux_Number		Output_type	VCS_ID	Video_Res_Sel	

This register should be written to all four video decoder cores.

**Interleave\_mode**

Interleave mode for multi-channel formats

- 00 Non-interleaved (a.k.a. 1-Ch mode) – (default)
- 01 Pixel-interleaved mode (2-Ch and 4-Ch only)
- 10 Line-interleaved mode
- 11 Line-interleaved, hybrid mode (adds 1-Ch D1 to selected 4-Ch Half-D1, 4-Ch CIF or 8-Ch CIF format)

**Channel\_Mux\_Number**

Number of time-multiplexed channels

- 00 1-Ch (reserved)
- 01 2-Ch
- 10 4-Ch (or 4-Ch Half-D1 or CIF + 1-Ch D1 for line-interleaved, hybrid mode)  
8-Ch cascade (format depends on VCS\_ID, line-interleaved mode only)
  - Line-interleaved mode
    - 1st stage: 8-Ch Half-D1 or 8-Ch CIF (video port A)
    - 2nd stage: 4-Ch Half-D1 or 4-Ch CIF (video port A)
  - Line-interleaved, hybrid mode
    - 1st stage: 8-Ch CIF + 1-Ch D1 (video port A)
    - 2nd stage: 4-Ch CIF (video port A) and 1-Ch D1 (video port B)
- 11

**Output\_type**

Output interface type

- 0 8-bit ITU-R BT.656 interface (default)
- 1 16-bit ITU-R BT.601 interface (4-Ch D1 and 4-Ch Half-D1 line-interleaved modes only)

**VCS\_ID**

Video cascade stage ID. Set to 0 for normal operation. For line-interleaved mode only.

- 0 1st stage (channels 1 to 4) (default)
- 1 2nd stage (channels 5 to 8)

**Video\_Res\_Sel**

Video resolution select. Effects multi-channel OFM only.

- 00 D1 (default)
- 01 Reserved
- 10 Half-D1
- 11 CIF



**Table 4-69. AVD Output Control 2**

**Subaddress**      B1h  
**Default**          10h

7	6	5	4	3	2	1	0
LLC_En	Line_Crop_En	Quan_Ctrl		Line_ID_Ctrl	Chan_ID_SAVEAV_En	Chan_ID_Blank_En	Video_Det_SAVEAV_En

This register should be written to all four video decoder cores.

**LLC\_En**

Line-locked clock enable, active high. For non-interleaved mode only. For use with Port A only. For D1 resolution only.

0 Line-locked clock disabled (default)

1 Line-locked clock enabled

**Line\_Crop\_En**

AVD line cropping enable, active high. Effects both scaled and unscaled AVD outputs.

0 Cropping disabled (unscaled: 720 pixels/line, down-scaled: 360 pixels/line) – (default)

1 Cropping enabled (unscaled: 704 pixels/line, down-scaled: 352 pixels/line)

**Quan\_Ctrl**

10-bit to 8-bit quantization control. Dithering algorithm based on truncation error from previous pixel.

00 Enable simple truncation

01 Enable dithering (default)

10 Enable simple rounding

11 Reserved

**Line\_ID\_Ctrl**

Line ID control. For line-interleaved mode only.

0 Line ID continues counting through the vertical blanking interval - (default)

1 Line ID holds the terminal count from the end of active video through the vertical blanking interval

**Chan\_ID\_SAVEAV\_En**

Channel ID inserted in SAV/EAV codes enable, active high. For pixel-interleaved mode only. Always disabled for non-interleaved and line-interleaved modes.

0 Disabled (default)

1 Enabled

**Chan\_ID\_Blank\_En**

Channel ID inserted in blanking level enable, active high. For pixel-interleaved mode only. Always disabled for non-interleaved and line-interleaved modes.

0 Disabled (default)

1 Enabled

**Video\_Det\_SAVEAV\_En**

Video detection status inserted in SAV/EAV codes enable, active high. For non-interleaved and pixel-interleaved modes. Always enabled for line-interleaved mode.

0 VDET insertion disabled (default)

1 VDET insertion enabled

**Table 4-70. OFM Mode Control**

**Subaddress**        B2h  
**Default**            20h

7	6	5	4	3	2	1	0
Video_Port_B_En	Out_CLK_Freq_Ctl	OSC_OUT_En	Out_CLK_Pol_Sel	Out_CLK_Freq_Sel	Out_CLK_P_En	Out_CLK_N_En	Video_Port_En

This register only needs to be written to video decoder core 0.

**Video\_Port\_B\_En**

Video port B output enable for 6-Ch Half-D1 (2nd stage), active high

0      Video Port B disabled (default)

1      Video Port B enabled

**Out\_CLK\_Freq\_Ctl**

Output clock frequency control for 4-Ch Half-D1 + 1-Ch D1 and 8-Ch CIF + 1-Ch D1 line-interleaved, hybrid output formats only. Affects both OCLK\_P and OCLK\_N.

0      108 MHz (default)

1      81 MHz

**OSC\_OUT\_En**

Oscillator output enable, active high

0      OSC\_OUT disabled

1      OSC\_OUT enabled (default)

**Out\_CLK\_Pol\_Sel**

Output clock polarity select. Affects both OCLK\_P and OCLK\_N.

0      Non-inverted (default)

1      Inverted

**Out\_CLK\_Freq\_Sel**

Output clock frequency select for 2-ch pixel-interleaved mode only. Affects both OCLK\_P and OCLK\_N.

0      54 MHz (default)

1      27 MHz

**Out\_CLK\_P\_En**

Output data clock+ (OCLK\_P) enable, active high

0      OCLK\_P disabled (default)

1      OCLK\_P enabled

**Out\_CLK\_N\_En**

Output data clock- (OCLK\_N) enable, active high

0      OCLK\_N disabled (default)

1      OCLK\_N enabled (for 2-Ch mode only)

**Video\_Port\_En**

Video port output enable, active high

0      All four video ports disabled (default)

1      All video ports required for selected output format enabled

**Table 4-71. OFM Channel Select 1**

**Subaddress**            B3h  
**Default**                E4h

7	6	5	4	3	2	1	0
Chan_Sel_Port_D		Chan_Sel_Port_C		Chan_Sel_Port_B		Chan_Sel_Port_A	

This register only needs to be written to video decoder core 0. OFM channel select by video port in 1-Ch mode.

**Chan\_Sel\_Port\_D**

Channel select for port D

00 Ch 1  
01 Ch 2  
10 Ch 3  
11 Ch 4 (default)

**Chan\_Sel\_Port\_C**

Channel select for port C

00 Ch 1  
01 Ch 2  
10 Ch 3 (default)  
11 Ch 4

**Chan\_Sel\_Port\_B**

Channel select for port B

00 Ch 1  
01 Ch 2 (default)  
10 Ch 3  
11 Ch 4

**Chan\_Sel\_Port\_A**

Channel select for port A

00 Ch 1 (default)  
01 Ch 2  
10 Ch 3  
11 Ch 4

NOTE: Each video port must be set to a different channel.

**Table 4-72. OFM Channel Select 2**

**Subaddress**        B4h  
**Default**            E4h

7	6	5	4	3	2	1	0
2nd_Chan_Sel_Port_B		1st_Chan_Sel_Port_B		2nd_Chan_Sel_Port_A		1st_Chan_Sel_Port_A	

This register only needs to be written to video decoder core 0. OFM channel select by video port in 2-Ch mode.

**2nd\_Chan\_Sel\_Port\_B**

Second channel select for port B

- 00 Ch 1
- 01 Ch 2
- 10 Ch 3
- 11 Ch 4 (default)

**1st\_Chan\_Sel\_Port\_B**

First channel select for port B

- 00 Ch 1
- 01 Ch 2
- 10 Ch 3 (default)
- 11 Ch 4

**2nd\_Chan\_Sel\_Port\_A**

Second channel select for port A

- 00 Ch 1
- 01 Ch 2 (default)
- 10 Ch 3
- 11 Ch 4

**1st\_Chan\_Sel\_Port\_A**

First channel select for port A

- 00 Ch 1 (default)
- 01 Ch 2
- 10 Ch 3
- 11 Ch 4

NOTE: Each video port must be set to a different channel.

**Table 4-73. OFM Channel Select 3**

**Subaddress**        B5h  
**Default**            00h

7	6	5	4	3	2	1	0
Reserved					Hybrid_Chan_Sel [2:0]		

This register only needs to be written to video decoder core 0.

**Hybrid\_Chan\_Sel [2:0]**

OFM channel select for 1-Ch D1 channel in video cascade mode and hybrid format mode.

- 000 Ch 1 (default)
- 001 Ch 2
- 010 Ch 3
- 011 Ch 4
- 100 Cascade input from Port C (for video cascade 1st stage only)
- 101 Reserved
- 110 Reserved
- 111 Reserved

**Table 4-74. OFM Super-Frame Size**

**Subaddress** B6h-B7h  
**Default** 041Bh

Subaddress	7	6	5	4	3	2	1	0
B6h	Super_Frame_Size [7:0]							
B7h	Reserved		Ctrl_Mode [1:0]		Super_Frame_Size [11:8]			

These registers write to decoder core 0 only.

Ctrl\_Mode [1:0]

Super-frame size control mode

- 00 Super-frame size based on 525-line standard (default)
- 01 Super-frame size based on 625-line standard
- 10 Reserved
- 11 Super-frame size based on manual setting (see subaddress B6h/B7h)

Super\_Frame\_Size [11:0]

Total number of lines per super-frame. For line-interleaved mode only.

- 0100 0001 1011 1051 (default)

NOTE: Has no effect on port B in the video cascade interface.

**Table 4-75. OFM EAV2SAV Duration**

**Subaddress** B8h-B9h  
**Default** 0040h

Subaddress	7	6	5	4	3	2	1	0
B8h	OFM_EAV2SAV_Duration [7:0]							
B9h	Horizontal_Freq_Tol			EAV2SAV_Duration_Mode	Reserved		OFM_EAV2SAV_Duration [9:8]	

These registers only need to be written to video decoder core 0.

Horizontal\_Freq\_Tol

Nominal horizontal frequency tolerance (%). Only has an affect when bit 4 is set to 0.

- 000 0.5% (longest EAV2SAV duration) (default)
- 001 1.0%
- 010 1.5%
- 011 2.0%
- 100 2.5%
- 101 3.0%
- 110 3.5%
- 111 4.0% (shortest EAV2SAV duration)

EAV2SAV\_Duration\_Mode

EAV2SAV duration control mode.

- 0 EAV2SAV duration automatically controlled
- 1 EAV2SAV duration based on manual setting (see subaddress B8h/B9h)

OFM\_EAV2SAV\_Duration [9:0]

EAV2SAV duration in OCLK\_P clock cycles. For non-interleaved and line-interleaved modes.

- 00 0100 0000 64 (default)

---

**NOTE**

See result of automatic EAV2SAV duration algorithm at status registers D0h-D1h.

---

**Table 4-76. Misc OFM Control**

**Subaddress**      BAh  
**Default**          00h

7	6	5	4	3	2	1	0
Reserved							OFM_Soft_Reset

**OFM\_Soft\_Reset**

Soft reset for OFM logic.

NOTE: This bit is automatically cleared by firmware when the reset is completed.

- 0      Normal operation (default)
- 1      Reset output formatter logic

NOTE: In cascade mode, the OFM reset of the 1st stage should be asserted after the OCLK\_N output of the 2nd stage is enabled.

**Table 4-77. Audio Sample Rate Control**

**Subaddress**      C0h  
**Default**          00h

7	6	5	4	3	2	1	0
Reserved				Aud_SamRate_Set[2:0]			Reserved

**Aud\_SamRate\_Set[2:0]**

Audio sample rate control bits

- 000    16 kHz (default)
- 001    8 kHz
- 010    22.05 kHz
- 011    11.025 kHz
- 100    24 kHz
- 101    12 kHz
- 110    Reserved
- 111    Reserved

**Table 4-78. Analog Audio Gain Control 1**

<b>Subaddress</b>	C1h							
<b>Default</b>	88h							
	7	6	5	4	3	2	1	0
	Audio_Gain_Ctrl_CH2				Audio_Gain_Ctrl_CH1			

**Audio\_Gain\_Ctrl\_CH2**

Analog audio gain control for audio Ch 2. See values below.

**Audio\_Gain\_Ctrl\_CH1**

Analog audio gain control for audio Ch 1

0000	-12.0 dB
0001	-10.5 dB
0010	-9 dB
0011	-7.5 dB
0100	-6 dB
0101	-4.5 dB
0110	-3 dB
0111	-1.5 dB
1000	0 dB (default)
1001	Reserved
1010	Reserved
1011	Reserved
1100	Reserved
1101	Reserved
1110	Reserved
1111	Reserved

**Table 4-79. Analog Audio Gain Control 2**

**Subaddress** C2h  
**Default** 88h

7	6	5	4	3	2	1	0
Audio_Gain_Ctrl_CH4				Audio_Gain_Ctrl_CH3			

**Audio\_Gain\_Ctrl\_CH4**

Analog audio gain control for audio Ch 4. See values below.

**Audio\_Gain\_Ctrl\_CH3**

Analog audio gain control for audio Ch 3

- 0000 -12.0 dB
- 0001 -10.5 dB
- 0010 -9 dB
- 0011 -7.5 dB
- 0100 -6 dB
- 0101 -4.5 dB
- 0110 -3 dB
- 0111 -1.5 dB
- 1000 0 dB (default)
- 1001 Reserved
- 1010 Reserved
- 1011 Reserved
- 1100 Reserved
- 1101 Reserved
- 1110 Reserved
- 1111 Reserved



**Table 4-80. Audio Mode Control**

**Subaddress** C3h  
**Default** C9h

7	6	5	4	3	2	1	0
SD_M_En	SD_R_En	I2S_Mode	Serial_IF_Format	BCLK_R_Freq	Audio_Data_Format		TDM_Pin_Sel

**SD\_M\_En**

SD\_M output enable, active high

0 SD\_M output disabled

1 SD\_M output enabled (default)

**SD\_R\_En**

SD\_R output enable, active high.

0 SD\_R output disabled

1 SD\_R output enabled (default)

**I2S\_Mode**

 Audio serial I<sup>2</sup>S interface mode

0 Slave mode (default)

1 Master mode

**Serial\_IF\_Format**

Audio serial interface format

 0 I<sup>2</sup>S justified mode (default)

1 DSP justified mode

**BCLK\_R\_Freq**

Audio serial interface BCLK\_R clock frequency

 0 256 f<sub>s</sub>

 1 64 f<sub>s</sub> (stand alone operation only) (default)

**Audio\_Data\_Format**

Audio serial interface data format

00 16-bit PCM (default)

 01 8-bit  $\mu$ -Law

10 8-bit A-Law

11 Reserved

**TDM\_Pin\_Sel**

TDM output pin select

0 SD\_R only

1 SD\_R and SD\_M (default)

**Table 4-81. Audio Mixer Select**

**Subaddress** C4h  
**Default** 01h

7	6	5	4	3	2	1	0
Audio_Mixer_Sel [4:0]					TDM_Chan_Number [2:0]		

Audio\_Mixer\_Sel [4:0]

Audio mixer output select

- 00000 Mix channel (default)
- 00001 Ch 1
- 00010 Ch 2
- 00011 Ch 3
- 00100 Ch 4
- 00101 Ch 5
- 00110 Ch 6
- 00111 Ch 7
- 01000 Ch 8
- 01001 Ch 9
- 01010 Ch 10
- 01011 Ch 11
- 01100 Ch 12
- 01101 Ch 13
- 01110 Ch 14
- 01111 Ch 15
- 10000 Ch 16
- 10001
- to Reserved
- 11111

TDM\_Chan\_Number [2:0]

Number of Audio channels to TDM

- 000 2 channels
- 001 4 channels (default)
- 010 8 channels
- 011 12 channels
- 100 16 channels
- 101 Reserved
- 110 Reserved
- 111 Reserved

**Table 4-82. Audio Mute Control**

**Subaddress** C5h  
**Default** 00h

7	6	5	4	3	2	1	0
Reserved				Ch4_Mute	Ch3_Mute	Ch2_Mute	Ch1_Mute

**Ch4\_Mute**

Ch 4 Audio mute enable, active high. Affects the audio mixer output (SD\_M) only (see [Figure 3-17](#)).

0 Disabled (default)  
1 Enabled

**Ch3\_Mute**

Ch 3 Audio mute enable, active high. Affects the audio mixer output (SD\_M) only (see [Figure 3-17](#)).

0 Disabled (default)  
1 Enabled

**Ch2\_Mute**

Ch 2 Audio mute enable, active high. Affects the audio mixer output (SD\_M) only (see [Figure 3-17](#)).

0 Disabled (default)  
1 Enabled

**Ch1\_Mute**

Ch 1 Audio mute enable, active high. Affects the audio mixer output (SD\_M) only (see [Figure 3-17](#)).

0 Disabled (default)  
1 Enabled

**Table 4-83. Analog Mixing Ratio Control 1**

**Subaddress** C6h  
**Default** 00h

7	6	5	4	3	2	1	0
Audio_Mixing_Ratio_CH2				Audio_Mixing_Ratio_CH1			

**Audio\_Mixing\_Ratio\_CH2**

Audio mixing ratio for audio channel 2. See values below.

**Audio\_Mixing\_Ratio\_CH1**

Audio mixing ratio for audio channel 1

0000 0.25 (default)  
0001 0.31  
0010 0.38  
0011 0.44  
0100 0.5  
0101 0.63  
0110 0.75  
0111 0.88  
1000 1.00  
1001 1.25  
1010 1.5  
1011 1.75  
1100 2.00  
1101 2.25  
1110 2.5  
1111 2.75

**Table 4-84. Analog Mixing Ratio Control 2**

**Subaddress** C7h  
**Default** 00h

7	6	5	4	3	2	1	0
Audio_Mixing_Ratio_CH4				Audio_Mixing_Ratio_CH3			

**Audio\_Mixing\_Ratio\_CH4**

Audio mixing ratio for audio channel 4. See values below.

**Audio\_Mixing\_Ratio\_CH3**

Audio mixing ratio for audio channel 3

0000	0.25 (default)
0001	0.31
0010	0.38
0011	0.44
0100	0.5
0101	0.63
0110	0.75
0111	0.88
1000	1.00
1001	1.25
1010	1.5
1011	1.75
1100	2.00
1101	2.25
1110	2.5
1111	2.75

**Table 4-85. Audio Cascade Mode Control**

**Subaddress** C8h  
**Default** 00h

7	6	5	4	3	2	1	0
Reserved						Audio_Cas_Mode_Ctrl	

**Audio\_Cas\_Mode\_Ctrl**

Audio Cascade Mode control which is cascade stage ID. Set to 00 for standalone operation.

00	First stage (channels 1 to 4) (default)
01	Second stage (channels 5 to 8)
10	Third stage (channels 9 to 12)
11	Fourth stage (channels 13 to 16)

**Table 4-86. Super-Frame EAV2SAV Duration Status**

**Subaddress** D0h-D1h  
**Default** Read Only

Subaddress	7	6	5	4	3	2	1	0
D0h	EAV2SAV [7:0]							
D1h	Reserved						EAV2SAV [9:8]	

**EAV2SAV [9:0]**

Super-frame EAV2SAV duration (bytes). For line-interleaved mode only.

**Table 4-87. Super-Frame SAV2EAV Duration Status**

**Subaddress** D2h-D3h  
**Default** Read Only

Subaddress	7	6	5	4	3	2	1	0
D2h	SAV2EAV [7:0]							
D3h	Reserved					EAV2SAV [10:8]		

SAV2EAV [10:0]

Super-frame SAV2EAV duration (bytes). For line-interleaved mode only.

**Table 4-88. VBUS Data Access With No VBUS Address Increment**

**Subaddress** E0h  
**Default** 00h

7	6	5	4	3	2	1	0
VBUS data [7:0]							

VBUS data [7:0]

VBUS data register for VBUS single-byte read/write transaction

**Table 4-89. VBUS Data Access With VBUS Address Increment**

**Subaddress** E1h  
**Default** 00h

7	6	5	4	3	2	1	0
VBUS data [7:0]							

VBUS data [7:0]

VBUS data register for VBUS multi-byte read/write transaction. VBUS address is auto-incremented after each data byte read/write.

**Table 4-90. VBUS Address Access**

**Subaddress** E8h E9h EAh  
**Default** 00h 00h 00h

Subaddress	7	6	5	4	3	2	1	0
E8h	VBUS address [7:0]							
E9h	VBUS address [15:8]							
EAh	VBUS address [23:16]							

VBUS access address [23:0]

VBUS is a 24-bit wide internal bus. The user needs to program the 24-bit address of the internal register to be accessed via host port indirect access mode.

**Table 4-91. Interrupt Status**

**Subaddress**            F2h  
**Default**                Read Only

7	6	5	4	3	2	1	0
Reserved		Sig_Present	Weak_Sig	V_Lock	Macrovision	Vid_Std	Reserved

The host interrupt status register represents the interrupt status after applying mask bits. Therefore, the status bits are the result of a logical AND between the raw status and mask bits. The external interrupt pin is derived from this register as an OR function of all non-masked interrupts in this register.

Reading data from the corresponding register does not clear the status flags automatically. These flags are reset using the corresponding bits in the interrupt clear register.

**Sig\_Present**

Signal present change interrupt. This interrupt is asserted whenever there is a change in the signal present status (bit 7 of register 01h).

0     Not available  
1     Available

**Weak\_Sig**

Weak signal change interrupt. This interrupt is asserted whenever there is a change in the weak signal status (bit 6 of register 01h).

0     Not available  
1     Available

**V\_Lock**

Vertical lock change interrupt. This interrupt is asserted whenever there is a change in the vertical lock status (bit 2 of register 00h).

0     Not available  
1     Available

**Macrovision**

Macrovision change interrupt. This interrupt is asserted whenever there is a change in the Macrovision detection status (bits 2:0 of register 01h).

0     Not available  
1     Available

**Vid\_Std**

Video standard change interrupt. This interrupt is asserted whenever there is a change in the detected video standard (bits 2:0 of register 0Ch).

0     Not available  
1     Available

**Table 4-92. Interrupt Mask**

**Subaddress** F4h  
**Default** 00h

7	6	5	4	3	2	1	0
Reserved		Sig_Present	Weak_Sig	V_Lock	Macrovision	Vid_Std	Reserved

The host interrupt mask register can be used by the external processor to mask unnecessary interrupt sources for the interrupt status register bits, and for the external interrupt pin. The external interrupt is generated from all non-masked interrupt flags.

**Sig\_Present**

Signal present change interrupt mask

0 Interrupt disabled (default)

1 Interrupt enabled

**Weak\_Sig**

Weak signal change interrupt mask

0 Interrupt disabled (default)

1 Interrupt enabled

**V\_Lock**

Vertical lock change interrupt mask

0 Interrupt disabled (default)

1 Interrupt enabled

**Macrovision**

Macrovision change interrupt mask

0 Interrupt disabled (default)

1 Interrupt enabled

**Vid\_Std**

Video standard change interrupt mask

0 Interrupt disabled (default)

1 Interrupt enabled

**Table 4-93. Interrupt Clear**

**Subaddress** F6h  
**Default** 00h

7	6	5	4	3	2	1	0
Reserved		Sig_Present	Weak_Sig	V_Lock	Macrovision	Vid_Std	Reserved

The host interrupt clear register is used by the external processor to clear the interrupt status bits in the host interrupt status register. When no non-masked interrupts remain set in the register, the external interrupt pin also becomes inactive.

**Sig\_Present**

Signal present change interrupt clear

- 0 No effect (default)
- 1 Clear interrupt bit

**Weak\_Sig**

Weak signal change interrupt clear

- 0 No effect (default)
- 1 Clear interrupt bit

**V\_Lock**

Vertical lock change interrupt clear

- 0 No effect (default)
- 1 Clear interrupt bit

**Macrovision**

Macrovision change interrupt clear

- 0 No effect (default)
- 1 Clear interrupt bit

**Vid\_Std**

Video standard change interrupt clear

- 0 No effect (default)
- 1 Clear interrupt bit

**Table 4-94. Decoder Write Enable**

**Subaddress** FEh  
**Default** 0Fh

7	6	5	4	3	2	1	0
Reserved		Addr Auto Incr	Decoder Auto Incr	Decoder 4	Decoder 3	Decoder 2	Decoder 1

This register controls which of the four decoder cores receives I<sup>2</sup>C write transactions. A 1 in the corresponding Decoder bit enables the decoder to receive write commands. Any combination of decoders can be configured to receive write commands, allowing all four decoders to be programmed concurrently.

The following table shows how the address auto-increment and decoder auto-increment functions operate when a multi-byte I<sup>2</sup>C write transaction occurs. For this example, decoders 2, 3 and 4 are enabled for writes, the subaddress is 0xA0 and 8 bytes of data are written.

Decoder Auto Incr	0		0		1		1	
	0		1		0		1	
Addr Auto Incr	Dec	Addr	Dec	Addr	Dec	Addr	Dec	Addr
1st	2,3,4	A0	2,3,4	A0	2	A0	2	A0
2nd	2,3,4	A0	2,3,4	A1	3	A0	3	A0
3rd	2,3,4	A0	2,3,4	A2	4	A0	4	A0
4th	2,3,4	A0	2,3,4	A3	2	A0	2	A1
5th	2,3,4	A0	2,3,4	A4	3	A0	3	A1
6th	2,3,4	A0	2,3,4	A5	4	A0	4	A1
7th	2,3,4	A0	2,3,4	A6	2	A0	2	A2
8th	2,3,4	A0	2,3,4	A7	3	A0	3	A2



**Table 4-95. Decoder Read Enable**

**Subaddress** FFh  
**Default** 01h

7	6	5	4	3	2	1	0
Reserved		Addr Auto Incr	Decoder Auto Incr	Decoder 4	Decoder 3	Decoder 2	Decoder 1

This register controls which of the four decoder cores responds to I<sup>2</sup>C read transactions. A 1 in the corresponding bit position enables the decoder to respond to read commands. A 1 in Decoder Auto Increment reads the next byte from the next enabled decoder. If Decoder Auto Increment is 0 and more than one decoder is enabled for reading, then only the lowest numbered decoder responds. A 1 in Address Auto Increment causes the subaddress to increment after read(s) of the current subaddress are completed.

The following table shows how the address auto-increment and decoder auto-increment functions operate when a multi-byte I<sup>2</sup>C read transaction occurs. For this example, decoders 2, 3 and 4 are enabled for reads, the subaddress is 0xA0, and 8 bytes of data are read.

Decoder Auto Incr	0		0		1		1	
	0		1		0		1	
Addr Auto Incr	Dec	Addr	Dec	Addr	Dec	Addr	Dec	Addr
1st	2	A0	2	A0	2	A0	2	A0
2nd	2	A0	2	A1	3	A0	3	A0
3rd	2	A0	2	A2	4	A0	4	A0
4th	2	A0	2	A3	2	A0	2	A1
5th	2	A0	2	A4	3	A0	3	A1
6th	2	A0	2	A5	4	A0	4	A1
7th	2	A0	2	A6	2	A0	2	A2
8th	2	A0	2	A7	3	A0	3	A2

## 5 Electrical Specifications

### 5.1 Absolute Maximum Ratings<sup>(1)</sup>

over operating free-air temperature range (unless otherwise noted)

V <sub>DD</sub>	Supply voltage range	VDD_3_3 to VSS_3_3		0.5 V to 4.0 V	
		VDD_1_1 to VSS_1_1		-0.2 V to 1.2 V	
		VDDA_3_3 to VSSA_3_3		-0.3 V to 3.6 V	
		VDDA_1_8 to VSSA_1_8		-0.2 V to 2.0 V	
		VDDA_1_1 to VSSA_1_1		-0.2 V to 1.2 V	
V <sub>I</sub>	Digital input voltage range	V <sub>I</sub> to DGND		-0.5 V to 4.5 V	
V <sub>O</sub>	Digital output voltage range	V <sub>O</sub> to DGND		-0.5 V to 4.5 V	
	Analog video input voltage range	A <sub>IN</sub> to AGND		-0.2 V to 2.5 V	
	Analog audio input voltage range	A <sub>IN</sub> to AGND		-0.2 V to 2.0 V	
T <sub>A</sub>	Operating free-air temperature range	Commercial range		0°C to 70°C	
		Industrial range		-40°C to 85°C	
T <sub>stg</sub>	Storage temperature range			-65°C to 150°C	
V <sub>ESD</sub>	ESD stress voltage <sup>(2)</sup>	Human-body model (HBM)	JEDEC <sup>(3)</sup>	All pins	>500 V
				Excluding VSSA, VDD1_1, XTAL_REF pins	>1000 V
			AEC-Q100 <sup>(4)</sup>	All pins	>500 V
				Excluding VSSA, VDD1_1, XTAL_REF pins	>1000 V
		Charged-device model (CDM)	JEDEC <sup>(5)</sup>	All pins	>250 V
				Excluding VSSA, VDD1_1, XTAL_REF pins	>500 V
AEC-Q100 <sup>(6)</sup>	All pins	>400 V			

(1) Stresses beyond those listed under *absolute maximum ratings* may cause permanent damage to the device. These are stress ratings only, and functional operation of the device at these or any other conditions beyond those indicated under *recommended operating conditions* is not implied. Exposure to absolute-maximum-rated conditions for extended periods may affect device reliability.

(2) Electrostatic discharge (ESD) to measure device sensitivity/immunity to damage caused by electrostatic discharges into the device.

(3) Level listed is the passing level per ANSI/ESDA/JEDEC JS-001-2010. JEDEC document JEP155 states that 500V HBM allows safe manufacturing with a standard ESD control process, and manufacturing with less than 500V HBM is possible if necessary precautions are taken. Pins listed as 1000V may actually have higher performance.

(4) Tested per AEC Q100-002 rev D

(5) Level listed is the passing level per EIA-JEDEC JESD22-C101E. JEDEC document JEP157 states that 250V CDM allows safe manufacturing with a standard ESD control process. Pins listed s 250V may actually have higher performance.

(6) Tested per AEC Q100-011 rev B

## 5.2 Recommended Operating Conditions

		MIN	NOM	MAX	UNIT
VDD_3_3	Supply voltage, digital	3	3.3	3.6	V
VDD_1_1	Supply voltage, digital	1	1.1	1.2	V
VDDA_3_3	Supply voltage, analog	3	3.3	3.6	V
VDDA_1_8	Supply voltage, analog	1.65	1.8	1.95	V
VDDA_1_1	Supply voltage, analog	1	1.1	1.2	V
V <sub>I(pp)</sub>	Analog video input voltage (ac-coupling necessary) <sup>(1)</sup>		1.2		V
V <sub>I(pp)</sub>	Analog audio input voltage (ac-coupling necessary)		0.8		V
V <sub>IH</sub>	Input voltage high, digital <sup>(2) (3)</sup>	0.7 VDD_3_3			V
V <sub>IL</sub>	Input voltage low, digital <sup>(4) (3)</sup>		0.3 VDD_3_3		V
I <sub>OH</sub>	Output current: DVO outputs/OCLK_N <sup>(3)</sup>	V <sub>OUT</sub> = 2.4 V	-4		mA
I <sub>OL</sub>	Output current: DVO outputs/OCLK_N <sup>(3)</sup>	V <sub>OUT</sub> = 0.4 V	4		mA
I <sub>OH</sub>	Output current, OCLK_P <sup>(3)</sup>	V <sub>OUT</sub> = 2.4 V	-8		mA
I <sub>OL</sub>	Output current, OCLK_P <sup>(3)</sup>	V <sub>OUT</sub> = 0.4 V	8		mA
T <sub>A</sub>	Operating free-air temperature	Commercial	0	70	°C
		Industrial	-40	85	°C

(1) Specified based on a typical 100% Color Bar Signal

(2) Exception: 0.7 VDDA\_1\_8 for XTAL\_IN terminal

(3) Specified by design

(4) Exception: 0.3 VDDA\_1\_8 for XTAL\_IN terminal

## 5.3 Reference Clock Specifications

	MIN	NOM	MAX	UNIT
Frequency		27		MHz
Frequency tolerance <sup>(1)</sup>	-50		50	ppm

(1) This number is the required specification for the external crystal/oscillator and is not tested.

## 5.4 Electrical Characteristics

### 5.5 DC Electrical Characteristics

For minimum/maximum values: VDD\_1\_1 = 1.0 V to 1.2 V, VDD\_3\_3 = 3.0 V to 3.6 V, VDDA\_1\_1 = 1.0 V to 1.2 V, VDDA\_1\_8 = 1.65 V to 1.95 V, VDDA\_3\_3 = 3.0 V to 3.6 V

For typical values ( $T_A = 25^\circ\text{C}$ ): VDD\_1\_1 = 1.1 V, VDD\_3\_3 = 3.3 V, VDDA\_1\_1 = 1.1 V, VDDA\_1\_8 = 1.8 V, VDDA\_3\_3 = 3.3 V<sup>(1)</sup>

PARAMETER		TEST CONDITIONS	MIN	TYP	MAX	UNIT
I <sub>DD(33D)</sub>	3.3-V I/O digital supply current	2-Ch D1 mode at 54 MHz		33		mA
		4-Ch D1 mode at 108 MHz		41		mA
I <sub>DD(11D)</sub>	1.1-V core digital supply current	2-Ch D1 mode at 54 MHz		143		mA
		4-Ch D1 mode at 108 MHz		156		mA
I <sub>DD(33A)</sub>	3.3-V analog supply current	2-Ch D1 mode at 54 MHz		4.5		mA
		4-Ch D1 mode at 108 MHz		4.5		mA
I <sub>DD(18A)</sub>	1.8-V analog supply current	2-Ch D1 mode at 54 MHz		172		mA
		4-Ch D1 mode at 108 MHz		168		mA
I <sub>DD(11A)</sub>	1.1-V analog supply current	2-Ch D1 mode at 54 MHz		14		mA
		4-Ch D1 mode at 108 MHz		17		mA
P <sub>TOT</sub>	Total power dissipation, normal operation	2-Ch D1 mode at 54 MHz		606		mW
		4-Ch D1 mode at 108 MHz		643		mW
P <sub>APWD</sub>	Power dissipation with audio powered down	4-Ch D1 mode at 108 MHz		619		mW
P <sub>DOWN</sub>	Total power dissipation with power down (I <sup>2</sup> C register 1Ah set to FFh)			90		mW
I <sub>ikg</sub>	Input leakage current				20	μA
C <sub>I</sub>	Input capacitance <sup>(2)</sup>				8	pF
V <sub>OH</sub>	Output voltage high	I <sub>OH</sub> = -4 mA	0.8 VDD_3_3			V
V <sub>OL</sub>	Output voltage low	I <sub>OL</sub> = 4 mA			0.2 VDD_3_3	V

(1) Typical current measurements made with 4-Ch D1 video output at 108 MHz with 4-Ch audio.

(2) Specified by design

## 5.6 Video A/D Converters Electrical Characteristics

ADC sample rate = 27 MSPS for video Ch 1, Ch 2, Ch 3, Ch 4

PARAMETER	TEST CONDITIONS	MIN	TYP	MAX	UNIT	
Video ADC conversion rate			27		MHz	
$Z_i$	Input impedance, analog video inputs <sup>(1)</sup>	200			k $\Omega$	
$C_i$	Input capacitance, analog video inputs <sup>(1)</sup>			10	pF	
$V_{i(PP)}$	Full-scale input range of ADC <sup>(2)</sup>	$C_{coupling} = 0.1 \mu F$		1.4	V	
G	Nominal analog video gain <sup>(1)</sup>		-2.9		dB	
DNL	Absolute differential non-linearity <sup>(3)</sup>	AFE only		0.75	1	LSB
INL	Absolute integral non-linearity	AFE only		1	2.5	LSB
FR	Frequency response	Multiburst (60 IRE)		-0.9		dB
XTALK	Input crosstalk <sup>(1)</sup>	1 MHz		-50		dB
SNR	Signal-to-noise ratio (all channels) <sup>(4)</sup>	$f_{in} = 1 \text{ MHz}, 1.0 \text{ V}_{pp}$		54		dB
NS	Noise spectrum	Luma ramp (100 kHz to full, tilt null)		-51		dB
DP	Differential phase	Modulated ramp		0.5		deg
DG	Differential gain	Modulated ramp		$\pm 1.5$		%

(1) Specified by design

(2) Full range video

(3) No missing codes

(4) Based on 10-bit internal ADC test mode

## 5.7 Audio A/D Converters Electrical Characteristics

ADC sample rate = 32.768 MSPS for audio Ch 1, Ch 2, Ch 3, Ch 4

PARAMETER	TEST CONDITIONS	MIN	TYP	MAX	UNIT	
Audio ADC conversion rate	$f_S = 16 \text{ kHz}$		32.768		MHz	
$Z_i$	Input impedance, analog audio inputs <sup>(1)</sup>	20			k $\Omega$	
$C_i$	Input capacitance, analog audio inputs <sup>(1)</sup>			10	pF	
$V_{i(PP)}$	Full-scale input voltage range of ADC	$C_{coupling} = 2.2 \mu F, 0\text{-dB PGA gain}$		1	V	
DNL	Absolute differential non-linearity <sup>(2)</sup>	AFE only		0.75	1	LSB
INL	Absolute integral non-linearity	AFE only		1	2.5	LSB
XTALK	Crosstalk between any two channels			-50		dB
SNR	Signal-to-noise ratio (all channels)	$f_S = 16 \text{ kHz}, V_{IN} = -60 \text{ dB}, 1 \text{ kHz}$		56		dB
	System clock frequency per channel			$512 f_S$	Hz	

(1) Specified by design

(2) No missing codes

### 5.8 Video Output Clock and Data Timing

10-pF load for 27 MHz and 54 MHz, 6-pF load for 108 MHz

NO.	PARAMETER	TEST CONDITIONS	MIN	TYP	MAX	UNIT
	Duty cycle, OCLK_P/OCLK_N	≤50%, OCLK_P/OCLK_N = 108 MHz	44	50	55	%
t3	Fall time, OCLK_P/OCLK_N	90% to 10%, OCLK_P/OCLK_N = 27 MHz			1.4	ns
		90% to 10%, OCLK_P/OCLK_N = 108 MHz			1.15	ns
t4	Rise time, OCLK_P/OCLK_N	10% to 90%, OCLK_P/OCLK_N = 27 MHz			1.4	ns
		10% to 90%, OCLK_P/OCLK_N = 108 MHz			1.15	ns
t1	Fall time, Data	90% to 10%, Data = 27 MHz			3.4	ns
		90% to 10%, Data = 108 MHz			2.9	
t2	Rise time, Data	10% to 90%, Data = 27 MHz			4.2	ns
		10% to 90%, Data = 108 MHz			3.4	
t5	Propagation delay from falling edge of OCLK_P/OCLK_N	50%, OCLK_P/OCLK_N = 27 MHz	1.9		4.86	ns
		50%, OCLK_P/OCLK_N = 108 MHz	0.22		1.5	ns

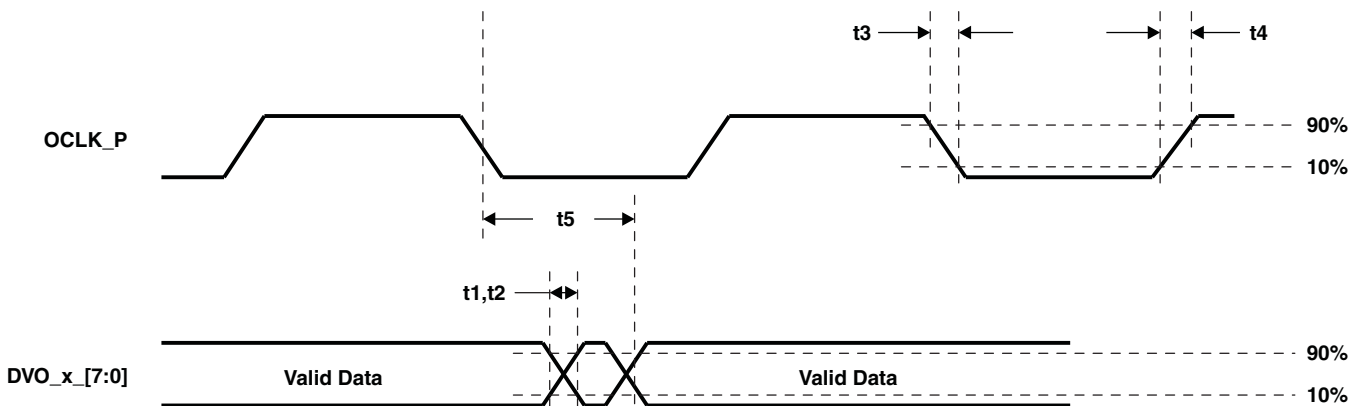

Figure 5-1. Video Output Clock and Data Timing

#### 5.8.1 Video Input Clock and Data Timing

**NOTE**

Video Cascade Modes: Timing is ensured by design at 27/54MHz input frequency with input trace delays < 2 ns.

### 5.9 I<sup>2</sup>C Host Port Timing<sup>(1)</sup>

NO.	PARAMETER	MIN	TYP	MAX	UNIT
t1	Bus free time between STOP and START	1.3			μs
t2	Data Hold time	0		0.9	μs
t3	Data Setup time	100			ns
t4	Setup time for a (repeated) START condition	0.6			μs
t5	Setup time for a STOP condition	0.6			ns
t6	Hold time (repeated) START condition	0.6			μs
t7	Rise time SDA and SCL signal			250	ns
t8	Fall time SDA and SCL signal			250	ns
C <sub>b</sub>	Capacitive load for each bus line			400	pF
f <sub>I2C</sub>	I <sup>2</sup> C clock frequency			400	kHz

(1) Specified by design

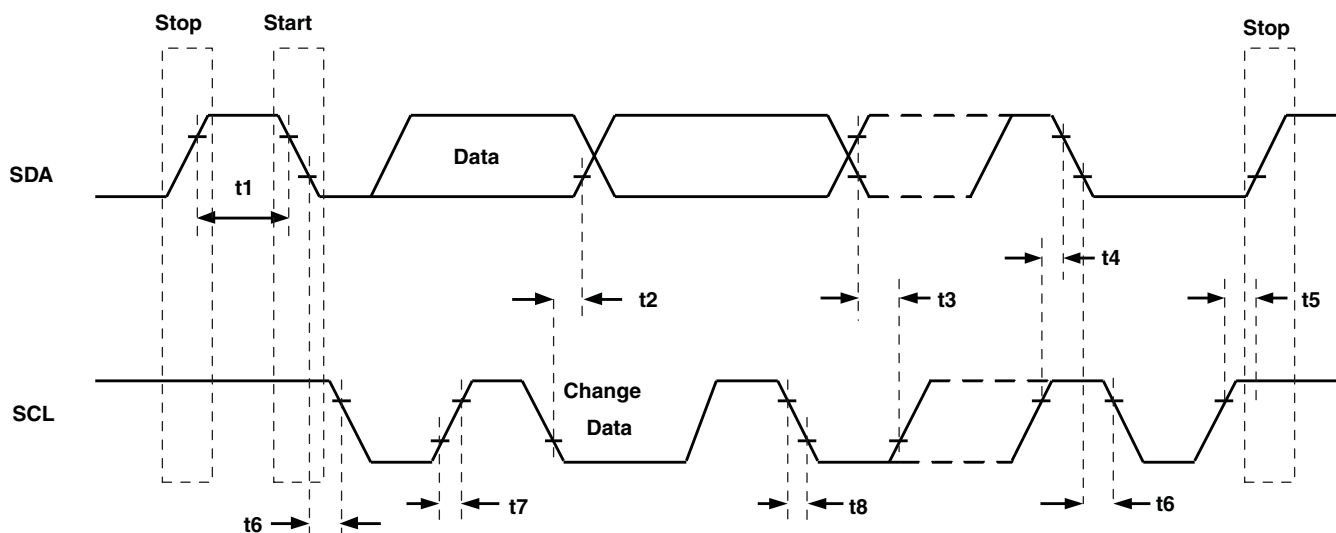

Figure 5-2. I<sup>2</sup>C Host Port Timing

### 5.9.1 I<sup>2</sup>S Port Timing

#### NOTE

Philips I<sup>2</sup>S bus compliant (specified by design) – See the Philips I<sup>2</sup>S bus specification

### 5.10 Miscellaneous Timings

PARAMETER		MIN	TYP	MAX	UNIT
t <sub>RESET</sub>	RESETB Signal Low Time for valid reset	20			ms
t <sub>valid</sub>	I <sup>2</sup> C valid time, Initialization time after reset until I <sup>2</sup> C ready	260			μs

### 5.11 Power Dissipation Ratings

PARAMETER		TEST CONDITIONS <sup>(1)</sup>	MIN	TYP	MAX	UNIT
θ <sub>JA</sub>	Junction-to-ambient thermal resistance, still air	Thermal PAD soldered to 4-layer High-K PCB		17.17		°C/W
θ <sub>JC</sub>	Junction-to-case thermal resistance, still air	Thermal PAD soldered to 4-layer High-K PCB		0.12		°C/W
T <sub>J</sub> (max)	Maximum junction temperature for reliable operation				105	°C

(1) Exposed thermal pad must be soldered to JEDEC High-K PCB with adequate ground plane (see [Section 6.5](#)).



## 6 Application Information

### 6.1 4-Ch D1 Applications

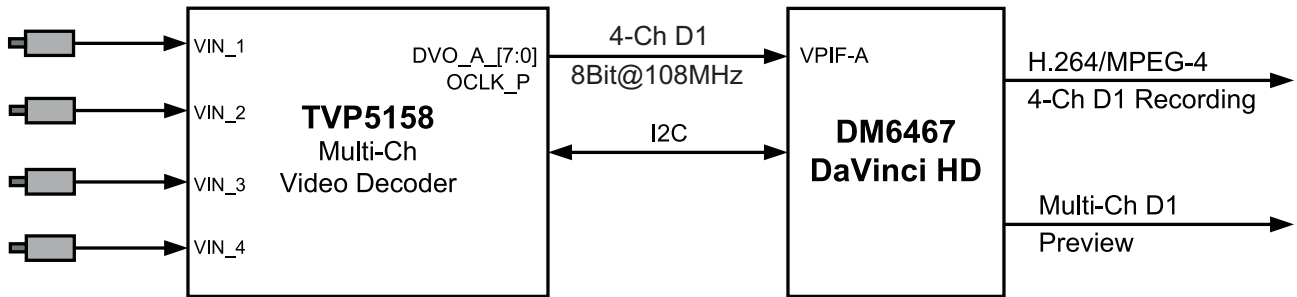

Figure 6-1. 4-Ch D1 Application (Single BT.656 Interface)

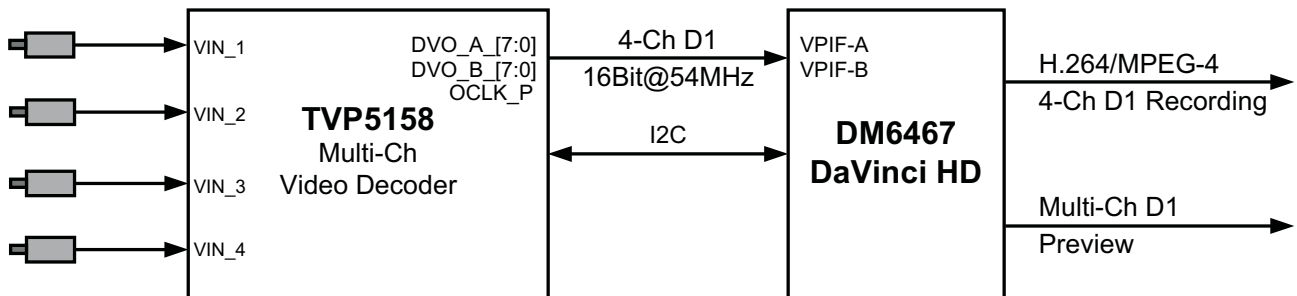

Figure 6-2. 4-Ch D1 Application (16-Bit YCbCr 4:2:2 Interface)

### 6.2 8-Ch CIF Applications

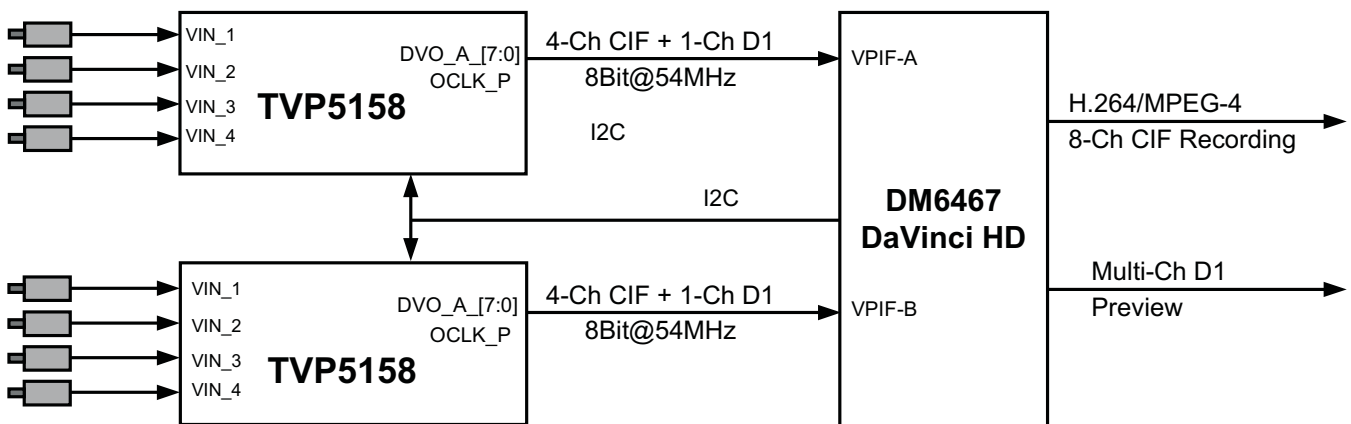
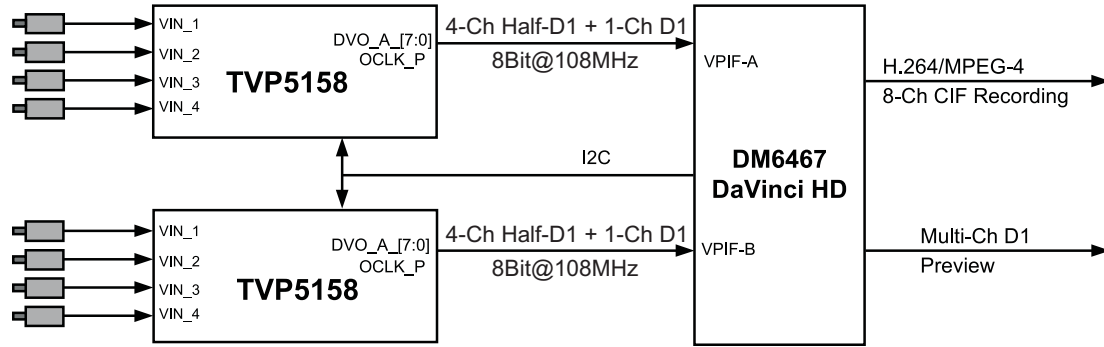

Figure 6-3. 8-Ch CIF Real Time Encoding and Multi-Ch D1 Preview Application



NOTE: The backend DSP drops one field of Half-D1 to get CIF format video

**Figure 6-4. 8-Ch CIF Real Time Encoding and Multi-Ch D1 Preview Application**

### 6.3 16-Ch CIF Applications

See [Section 3.8.3.3](#) for the details of 16-Ch CIF applications.

### 6.4 Application Circuit Examples

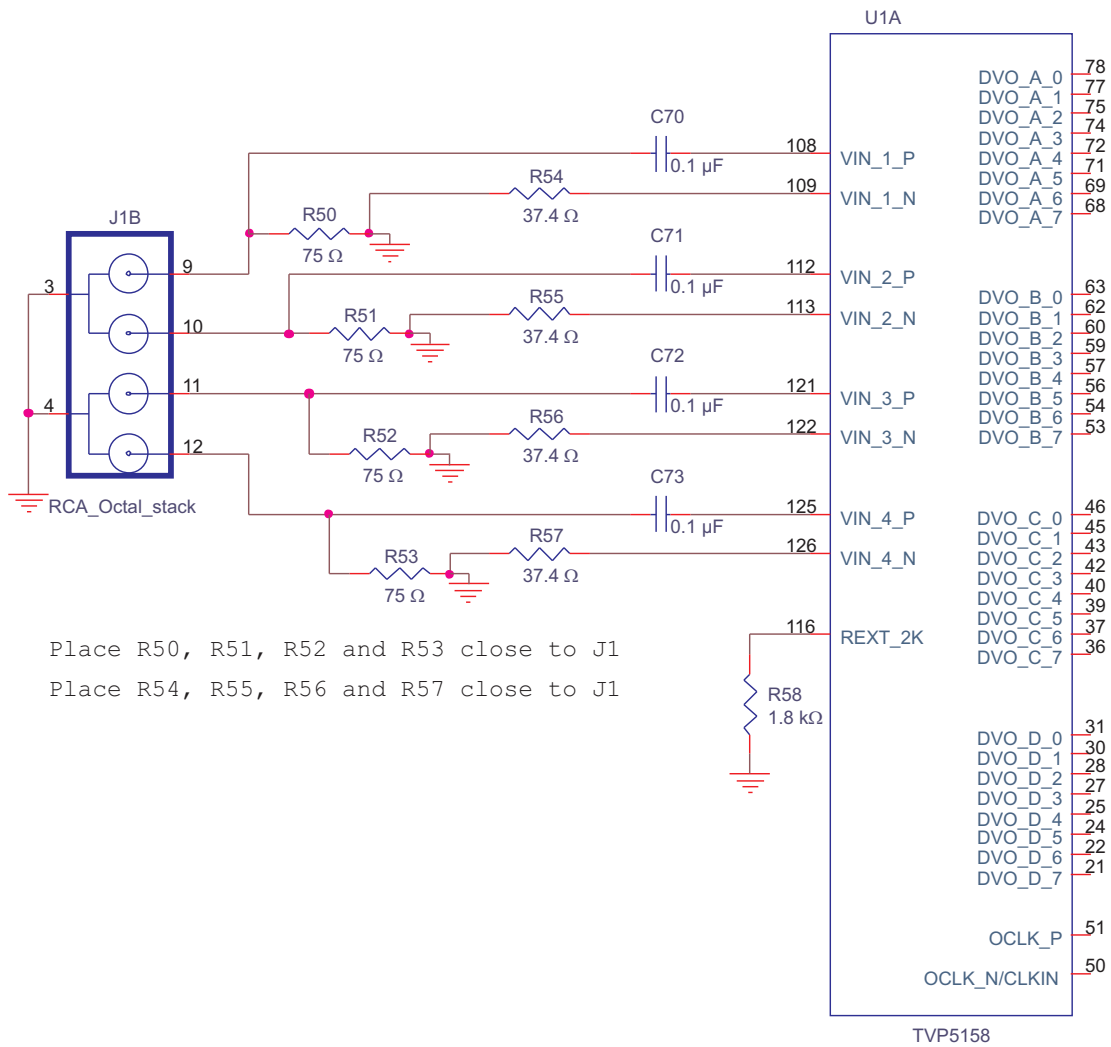

NOTE: System level ESD protection is not included in above application circuit but is recommended.

**Figure 6-5. Video Input Connectivity**

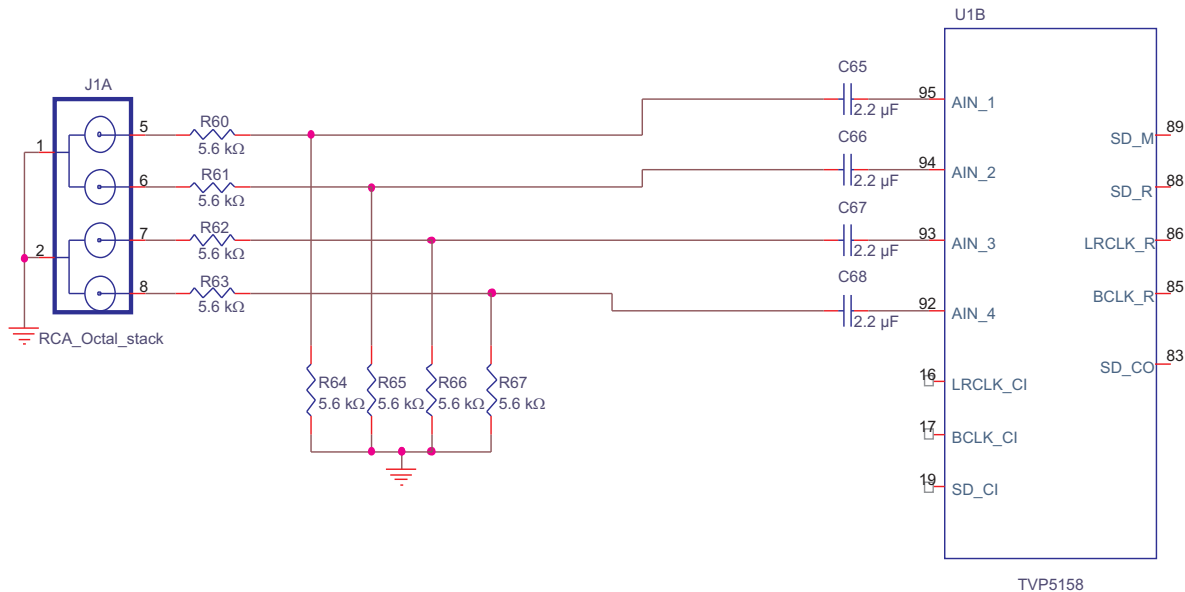

NOTE: System level ESD protection is not included in above application circuit but is recommended.

NOTE: Resistor divider may vary dependent on expected max input audio levels. Desired analog audio input levels should not exceed 1Vpp.

**Figure 6-6. Audio Input Connectivity**

## 6.5 Designing with PowerPAD™ Devices

The TVP5158 device is housed in a high-performance, thermally enhanced, 128-terminal PowerPAD package. Use of the PowerPAD package does not require any special considerations except to note that the thermal pad, which is an exposed die pad on the bottom of the device, is a metallic thermal and electrical conductor. Therefore, if not implementing the PowerPAD PCB features, the use of solder masks (or other assembly techniques) can be required to prevent any inadvertent shorting by the exposed thermal pad of connection etches or vias under the package. The recommended option, however, is not to run any etches or signal vias under the device, but to have only a grounded thermal land as in the following explanation. Although the actual size of the exposed die pad may vary, the minimum size required for the keep-out area for the 128-terminal PFP PowerPAD package is 9mm x 9mm.

It is recommended that there be a thermal land, which is an area of solder-tinned-copper, underneath the PowerPAD package. The thermal land varies in size, depending on the PowerPAD package being used, the PCB construction, and the amount of heat that needs to be removed. In addition, the thermal land may or may not contain numerous thermal vias depending on PCB construction.

Other requirements for using thermal lands and thermal vias are detailed in the TI application note *PowerPAD Thermally Enhanced Package* application report ([SLMA002](#)).

For the TVP5158 device, this thermal land must be grounded to the low-impedance ground plane of the device. This improves not only thermal performance but also the electrical grounding of the device. It is also recommended that the device ground terminal landing pads be connected directly to the grounded thermal land. The land size should be as large as possible without shorting device signal terminals. The thermal land can be soldered to the exposed thermal pad using standard reflow soldering techniques.

While the thermal land can be electrically floated and configured to remove heat to an external heat sink, it is recommended that the thermal land be connected to the low-impedance ground plane for the device. More information can be obtained from the TI application note PHY Layout ([SLLA020](#)).

## Revision History

NOTE: Page numbers for previous revisions may differ from page numbers in the current version.

REVISION	COMMENTS
SLES243	Initial release
SLES243A	<p><a href="#">Table 2-1</a>, XTAL_REF description change.</p> <p><a href="#">Figure 3-21</a>, 0-Ω resistor added inline between XTAL_REF pin and VSSA.</p>
SLES243B	<p>YUV references changed to YCbCr.</p> <p><a href="#">Section 1</a>, Trademarks added.</p> <p><a href="#">Table 2-1</a>, XTAL_IN, XTAL_REF, and XTAL_OUT terminal descriptions moved to Analog Section.</p> <p><a href="#">Section 3.1.2</a>, Analog Video Input Clamping description changed.</p> <p><a href="#">Section 3.9.4</a>, Analog Audio Input Clamping description added.</p> <p><a href="#">Section 3.11</a>, Clock Circuit description changed.</p>
SLES243C	<p><a href="#">Section 1.5</a>, Trademarks added.</p> <p><a href="#">Section 1.6</a>, Document Conventions added.</p> <p><a href="#">Section 1.7</a>, Package options added.</p> <p><a href="#">Section 3.9.3</a>, Serial Audio Interface added.</p> <p><a href="#">Figure 3-18</a>, Serial Audio Interface Timing Diagram added.</p> <p><a href="#">Table 4-14</a>, Luminance Brightness description modified.</p> <p><a href="#">Table 4-15</a>, Luminance Contrast description modified.</p> <p><a href="#">Table 4-16</a>, Brightness and Contrast Range Extender register added.</p> <p><a href="#">Table 4-17</a>, Chrominance Saturation description modified.</p> <p><a href="#">Table 4-65</a>, Interrupt Control register added.</p> <p>Minor editorial changes throughout.</p>
SLES243D	<p>AEC-Q100 qualification added.</p> <p><a href="#">Section 3.8.3.3</a>, Added comment about INTREQ outputs in video cascade mode</p> <p><a href="#">Section 3.10.3</a>, Added VBUS access information.</p> <p><a href="#">Table 4-1</a>, Added VBUS data and address registers.</p> <p><a href="#">Table 4-89</a>, Added VBUS data register description.</p> <p><a href="#">Table 4-90</a>, Added VBUS address register description.</p> <p><a href="#">Table 3-5</a>, Added output format settings for I<sup>2</sup>C address B0h.</p> <p><a href="#">Table 3-6</a>, Added output format settings for I<sup>2</sup>C address B0h.</p> <p><a href="#">Table 3-10</a>, Combined original <a href="#">Table 3-11</a> with <a href="#">Table 3-10</a>.</p> <p><a href="#">Table 3-10</a>, Added output format settings for I<sup>2</sup>C address B0h.</p> <p><a href="#">Section 3.8.3.4</a>, Added Hybrid Mode section.</p> <p><a href="#">Table 3-11</a>, Added default super-frame output format table.</p> <p><a href="#">Figure 3-15</a>, Made minor editorial changes.</p> <p><a href="#">Figure 3-16</a>, Made minor editorial changes.</p> <p><a href="#">Table 4-1</a>, Added super-frame EAV2SAV and SAV2EAV duration status (D0h-D3h)</p> <p><a href="#">Table 4-43</a>, Modified TV/VCR mode detection description.</p> <p><a href="#">Table 4-19</a>, Modified definition for color killer threshold control.</p> <p><a href="#">Table 4-43</a>, Deleted obsolete stable sync control bits.</p> <p><a href="#">Table 4-50</a>, Changed the default value for I<sup>2</sup>C address 88h from 00h to 03h.</p> <p><a href="#">Table 4-86</a>, Added super-frame EAV2SAV duration status (subaddress: D0h-D1h)</p> <p><a href="#">Table 4-87</a>, Added super-frame SAV2EAV duration status (subaddress: D2h-D3h)</p> <p><a href="#">Section 5.11</a>, Modified package thermal specifications.</p> <p>Minor editorial changes throughout</p>

REVISION	COMMENTS
SLES243E	<p><a href="#">Table 4-1</a>, Added RAM version MSB and LSB registers (subaddress: 05h-06h).</p> <p><a href="#">Table 4-6</a>, Added RAM version MSB register (subaddress: 05h).</p> <p><a href="#">Table 4-7</a>, Added RAM version LSB register (subaddress: 06h).</p> <p><a href="#">Section 5.1</a>, Updated <math>V_{ESD}</math> limits.</p>
SLES243F	<p><a href="#">Table 3-11</a>, Super-frame format and timing information modified.</p> <p><a href="#">Table 3-10</a>, 6-Ch Half-D1, 6-Ch Half-D1 + 1-Ch D1 and 3-Ch D1 formats added</p> <p><a href="#">Table 3-12</a>, Added BOP and EOP bits.</p> <p><a href="#">Table 3-13</a>, Added definitions for BOP and EOP bits.</p> <p><a href="#">Table 4-1</a>, Changed default setting for I<sup>2</sup>C register AEh from 00h to 01h.</p> <p><a href="#">Table 4-1</a>, Corrected register name for I<sup>2</sup>C register 06h.</p> <p><a href="#">Table 4-43</a>, Definitions for bits 7 and 3 of I<sup>2</sup>C register 60h added.</p> <p><a href="#">Table 4-52</a>, Output timing delay control range modified.</p> <p><a href="#">Table 4-54</a>, Register settings for several different screen colors provided.</p> <p><a href="#">Table 4-63</a>, YCbCr output code range modified.</p> <p><a href="#">Table 4-67</a>, Embedded sync offset control range modified.</p> <p><a href="#">Table 4-69</a>, Definition for bit 7 of I<sup>2</sup>C register B1h modified.</p> <p><a href="#">Table 4-70</a>, Definition for bit 7 of I<sup>2</sup>C register B2h added.</p> <p><a href="#">Table 4-75</a>, Definition for bits 7:5 of I<sup>2</sup>C register B9h added.</p> <p><a href="#">Table 4-77</a>, 11.025kHz, 12kHz, 22.05kHz and 24kHz audio sample rates added.</p> <p><a href="#">Table 4-82</a>, Definition for bits 3:0 of I<sup>2</sup>C register C5h modified.</p> <p><a href="#">Table 4-91</a>, Definition for bits 5:0 of I<sup>2</sup>C register F2h modified.</p> <p><a href="#">Table 4-92</a>, Definition for bits 5:0 of I<sup>2</sup>C register F4h modified.</p> <p><a href="#">Table 4-93</a>, Definition for bits 5:0 of I<sup>2</sup>C register F6h modified.</p>
SLES243G	<p><a href="#">Section 3.6</a>, Changed I2C addresses shown for Noise Reduction registers</p>

**PACKAGING INFORMATION**

Orderable Device	Status (1)	Package Type	Package Drawing	Pins	Package Qty	Eco Plan (2)	Lead finish/ Ball material (6)	MSL Peak Temp (3)	Op Temp (°C)	Device Marking (4/5)	Samples
TVP5157PNPR	LIFEBUY	HTQFP	PNP	128	1000	RoHS & Green	NIPDAU	Level-3-260C-168 HR	0 to 70	TVP5157	
TVP5158IPNP	ACTIVE	HTQFP	PNP	128	90	RoHS & Green	NIPDAU	Level-3-260C-168 HR	-40 to 85	TVP5158I	Samples
TVP5158IPNPR	ACTIVE	HTQFP	PNP	128	1000	RoHS & Green	NIPDAU	Level-3-260C-168 HR	-40 to 85	TVP5158I	Samples
TVP5158PNP	ACTIVE	HTQFP	PNP	128	90	RoHS & Green	NIPDAU	Level-3-260C-168 HR	0 to 70	TVP5158	Samples
TVP5158PNPR	ACTIVE	HTQFP	PNP	128	1000	RoHS & Green	NIPDAU	Level-3-260C-168 HR	0 to 70	TVP5158	Samples

(1) The marketing status values are defined as follows:

**ACTIVE:** Product device recommended for new designs.

**LIFEBUY:** TI has announced that the device will be discontinued, and a lifetime-buy period is in effect.

**NRND:** Not recommended for new designs. Device is in production to support existing customers, but TI does not recommend using this part in a new design.

**PREVIEW:** Device has been announced but is not in production. Samples may or may not be available.

**OBSELETE:** TI has discontinued the production of the device.

(2) **RoHS:** TI defines "RoHS" to mean semiconductor products that are compliant with the current EU RoHS requirements for all 10 RoHS substances, including the requirement that RoHS substance do not exceed 0.1% by weight in homogeneous materials. Where designed to be soldered at high temperatures, "RoHS" products are suitable for use in specified lead-free processes. TI may reference these types of products as "Pb-Free".

**RoHS Exempt:** TI defines "RoHS Exempt" to mean products that contain lead but are compliant with EU RoHS pursuant to a specific EU RoHS exemption.

**Green:** TI defines "Green" to mean the content of Chlorine (Cl) and Bromine (Br) based flame retardants meet JS709B low halogen requirements of <=1000ppm threshold. Antimony trioxide based flame retardants must also meet the <=1000ppm threshold requirement.

(3) MSL, Peak Temp. - The Moisture Sensitivity Level rating according to the JEDEC industry standard classifications, and peak solder temperature.

(4) There may be additional marking, which relates to the logo, the lot trace code information, or the environmental category on the device.

(5) Multiple Device Markings will be inside parentheses. Only one Device Marking contained in parentheses and separated by a "~" will appear on a device. If a line is indented then it is a continuation of the previous line and the two combined represent the entire Device Marking for that device.

(6) Lead finish/Ball material - Orderable Devices may have multiple material finish options. Finish options are separated by a vertical ruled line. Lead finish/Ball material values may wrap to two lines if the finish value exceeds the maximum column width.

**Important Information and Disclaimer:**The information provided on this page represents TI's knowledge and belief as of the date that it is provided. TI bases its knowledge and belief on information provided by third parties, and makes no representation or warranty as to the accuracy of such information. Efforts are underway to better integrate information from third parties. TI has taken and

continues to take reasonable steps to provide representative and accurate information but may not have conducted destructive testing or chemical analysis on incoming materials and chemicals. TI and TI suppliers consider certain information to be proprietary, and thus CAS numbers and other limited information may not be available for release.

In no event shall TI's liability arising out of such information exceed the total purchase price of the TI part(s) at issue in this document sold by TI to Customer on an annual basis.



## TAPE AND REEL INFORMATION



### QUADRANT ASSIGNMENTS FOR PIN 1 ORIENTATION IN TAPE



\*All dimensions are nominal

Device	Package Type	Package Drawing	Pins	SPQ	Reel Diameter (mm)	Reel Width W1 (mm)	A0 (mm)	B0 (mm)	K0 (mm)	P1 (mm)	W (mm)	Pin1 Quadrant
TVP5157PNPR	HTQFP	PNP	128	1000	330.0	24.4	17.0	17.0	1.5	20.0	24.0	Q1
TVP5158IPNPR	HTQFP	PNP	128	1000	330.0	24.4	17.0	17.0	1.5	20.0	24.0	Q1
TVP5158PNPR	HTQFP	PNP	128	1000	330.0	24.4	17.0	17.0	1.5	20.0	24.0	Q1

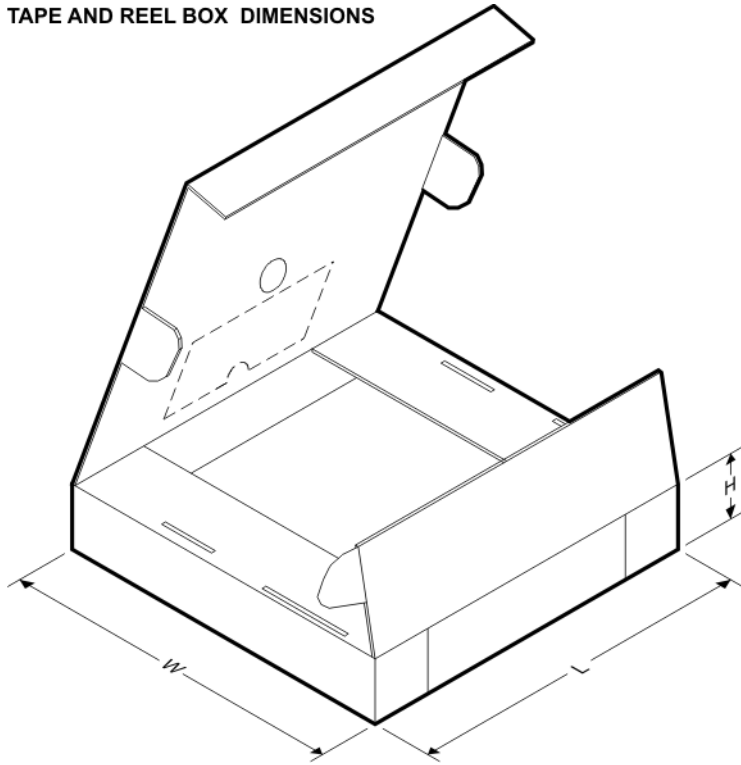
**TAPE AND REEL BOX DIMENSIONS**

\*All dimensions are nominal

Device	Package Type	Package Drawing	Pins	SPQ	Length (mm)	Width (mm)	Height (mm)
TVP5157PNPR	HTQFP	PNP	128	1000	367.0	367.0	55.0
TVP5158IPNPR	HTQFP	PNP	128	1000	367.0	367.0	55.0
TVP5158PNPR	HTQFP	PNP	128	1000	367.0	367.0	55.0

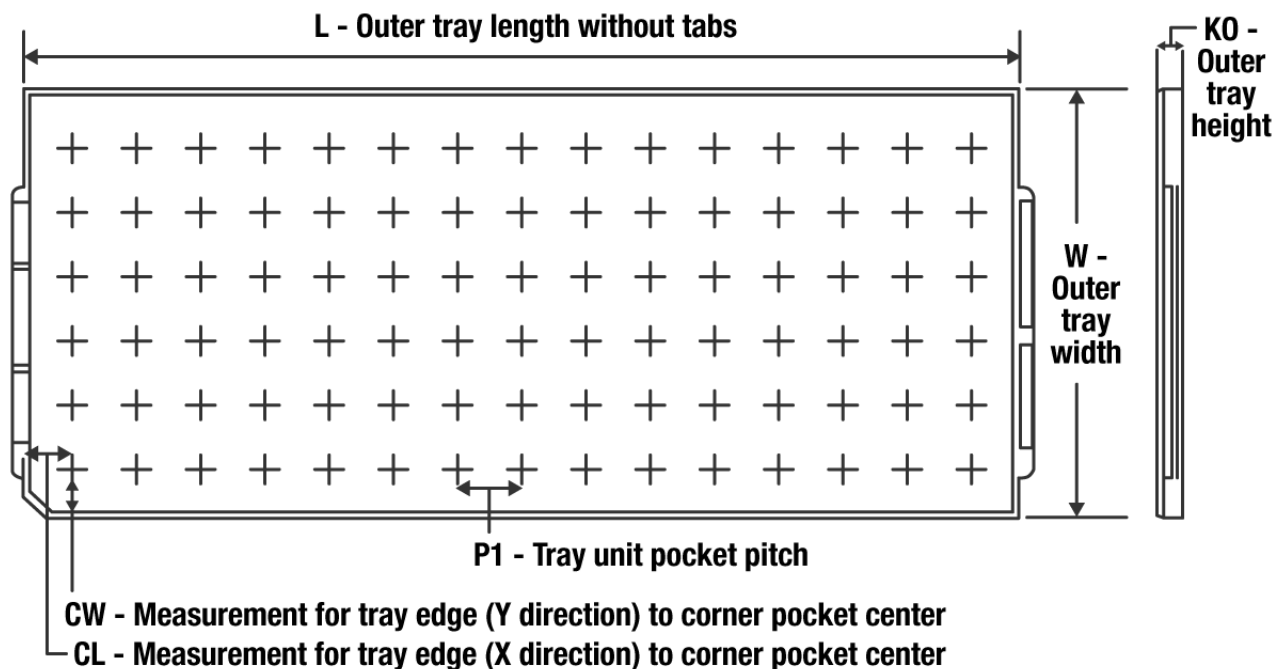
**TRAY**

Chamfer on Tray corner indicates Pin 1 orientation of packed units.

\*All dimensions are nominal

Device	Package Name	Package Type	Pins	SPQ	Unit array matrix	Max temperature (°C)	L (mm)	W (mm)	K0 (µm)	P1 (mm)	CL (mm)	CW (mm)
TVP5158IPNP	PNP	HTQFP	128	90	6 X 15	150	315	135.9	7620	15.4	20.3	21
TVP5158PNP	PNP	HTQFP	128	90	6 X 15	150	315	135.9	7620	15.4	20.3	21

# MECHANICAL DATA

PNP (S-PQFP-G128)

PowerPAD™ PLASTIC QUAD FLATPACK

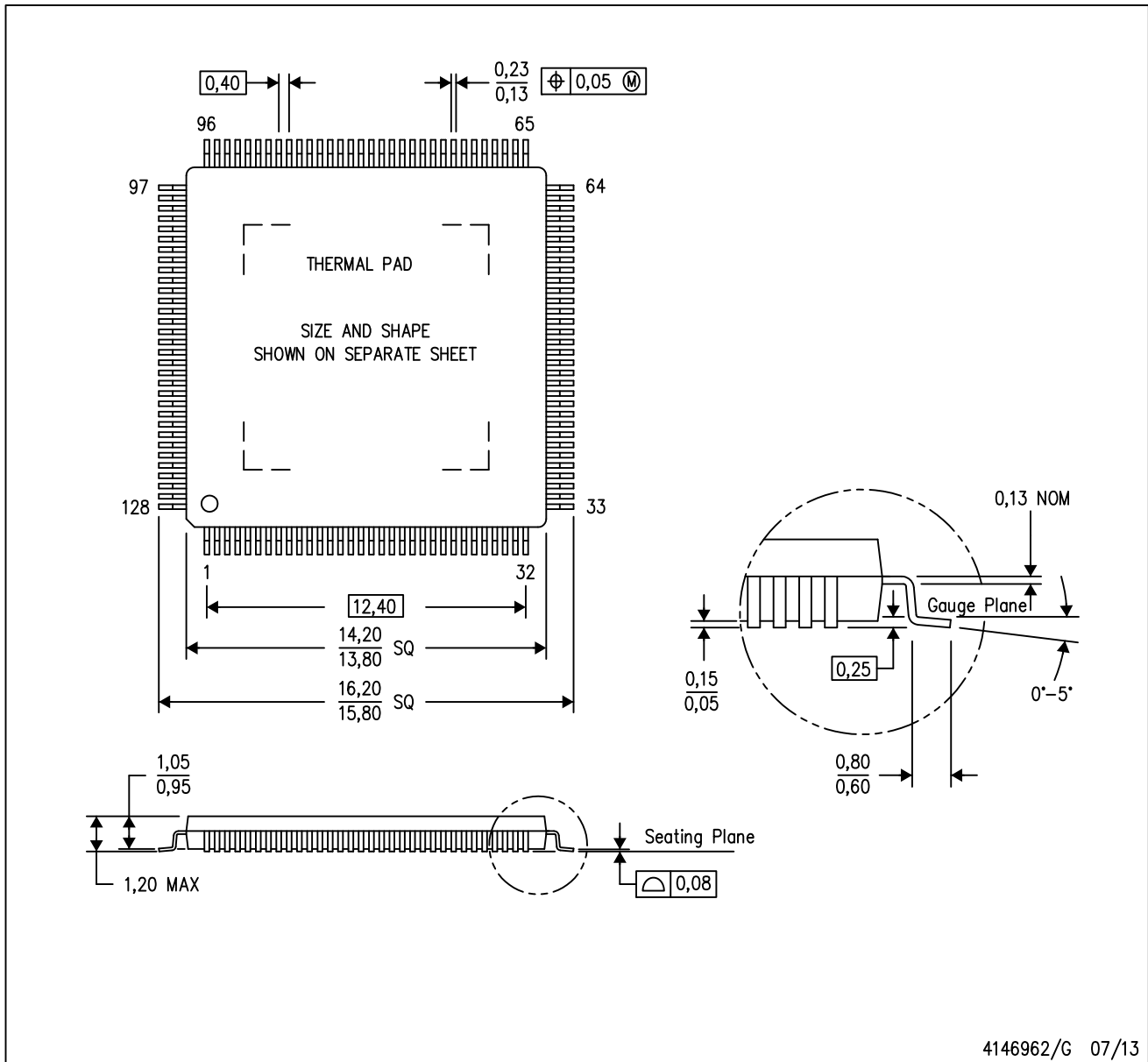

- NOTES:
- All linear dimensions are in millimeters.
  - This drawing is subject to change without notice.
  - Body dimensions do not include mold flash or protrusion
  - This package is designed to be soldered to a thermal pad on the board. Refer to Technical Brief, PowerPad Thermally Enhanced Package, Texas Instruments Literature No. SLMA002 for information regarding recommended board layout. This document is available at [www.ti.com](http://www.ti.com) <<http://www.ti.com>>.
  - See the additional figure in the Product Data Sheet for details regarding the exposed thermal pad features and dimensions.

PowerPAD is a trademark of Texas Instruments.

## THERMAL PAD MECHANICAL DATA

PNP (S-PQFP-G128)

PowerPAD™ PLASTIC QUAD FLATPACK

### THERMAL INFORMATION

This PowerPAD™ package incorporates an exposed thermal pad that is designed to be attached to a printed circuit board (PCB). The thermal pad must be soldered directly to the PCB. After soldering, the PCB can be used as a heatsink. In addition, through the use of thermal vias, the thermal pad can be attached directly to the appropriate copper plane shown in the electrical schematic for the device, or alternatively, can be attached to a special heatsink structure designed into the PCB. This design optimizes the heat transfer from the integrated circuit (IC).

For additional information on the PowerPAD package and how to take advantage of its heat dissipating abilities, refer to Technical Brief, PowerPAD Thermally Enhanced Package, Texas Instruments Literature No. SLMA002 and Application Brief, PowerPAD Made Easy, Texas Instruments Literature No. SLMA004. Both documents are available at [www.ti.com](http://www.ti.com).

The exposed thermal pad dimensions for this package are shown in the following illustration.

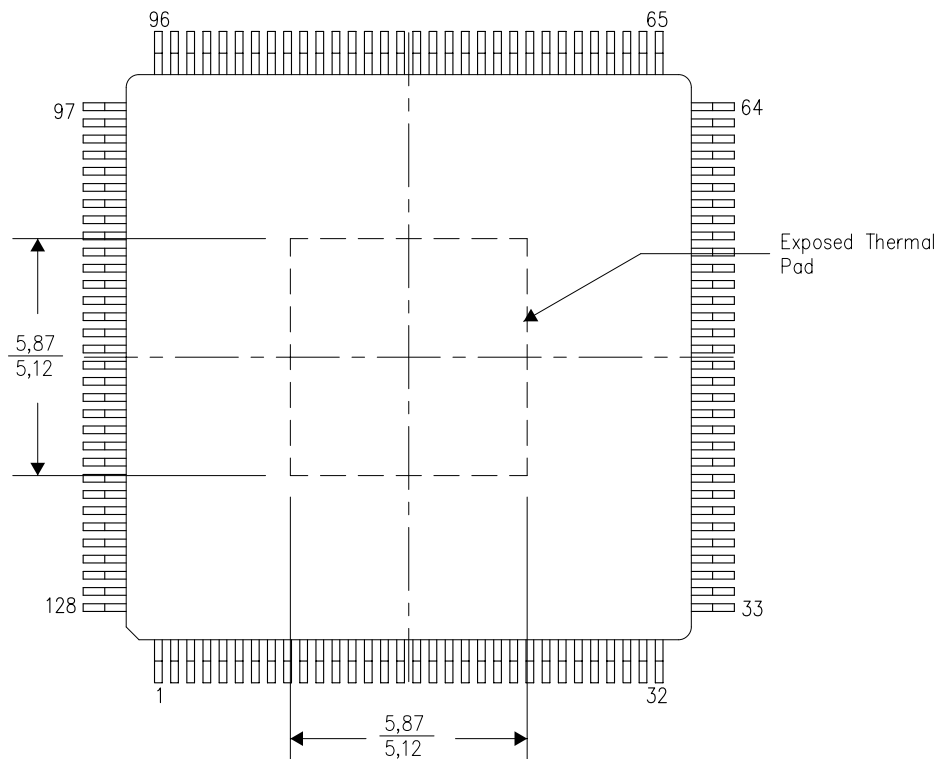

Exposed Thermal Pad Dimensions

4206232-12/L 10/11

NOTE: All linear dimensions are in millimeters

PowerPAD is a trademark of Texas Instruments

## IMPORTANT NOTICE AND DISCLAIMER

TI PROVIDES TECHNICAL AND RELIABILITY DATA (INCLUDING DATA SHEETS), DESIGN RESOURCES (INCLUDING REFERENCE DESIGNS), APPLICATION OR OTHER DESIGN ADVICE, WEB TOOLS, SAFETY INFORMATION, AND OTHER RESOURCES "AS IS" AND WITH ALL FAULTS, AND DISCLAIMS ALL WARRANTIES, EXPRESS AND IMPLIED, INCLUDING WITHOUT LIMITATION ANY IMPLIED WARRANTIES OF MERCHANTABILITY, FITNESS FOR A PARTICULAR PURPOSE OR NON-INFRINGEMENT OF THIRD PARTY INTELLECTUAL PROPERTY RIGHTS.

These resources are intended for skilled developers designing with TI products. You are solely responsible for (1) selecting the appropriate TI products for your application, (2) designing, validating and testing your application, and (3) ensuring your application meets applicable standards, and any other safety, security, regulatory or other requirements.

These resources are subject to change without notice. TI grants you permission to use these resources only for development of an application that uses the TI products described in the resource. Other reproduction and display of these resources is prohibited. No license is granted to any other TI intellectual property right or to any third party intellectual property right. TI disclaims responsibility for, and you will fully indemnify TI and its representatives against, any claims, damages, costs, losses, and liabilities arising out of your use of these resources.

TI's products are provided subject to [TI's Terms of Sale](#) or other applicable terms available either on [ti.com](https://www.ti.com) or provided in conjunction with such TI products. TI's provision of these resources does not expand or otherwise alter TI's applicable warranties or warranty disclaimers for TI products.

TI objects to and rejects any additional or different terms you may have proposed.

Mailing Address: Texas Instruments, Post Office Box 655303, Dallas, Texas 75265  
Copyright © 2024, Texas Instruments Incorporated