

# LM2576xx シリーズ SIMPLE SWITCHER<sup>®</sup>、電力コンバータ 3A 降圧型電圧レギュレータ

## 1 特長

- 利用可能な新製品:
  - LMR51430 4.5~36V、3A、500kHz および 1.1MHz 同期整流コンバータ
  - LM76003 3.5~60V、3.5A、300kHz~2.2MHz 同期整流コンバータ
- 市場投入の迅速化:
  - TLVM13630 3~36V、3A、200kHz~2.2MHz 電源モジュール
- 3.3V、5V、12V、15V、および可変出力のバージョン
- 可変出力電圧バージョンの出力電圧範囲は 1.23V~37V (HV バージョンは最大 57V)、入力と負荷の全条件で許容誤差は  $\pm 4\%$  以内
- 3A の出力電流を規定
- 広い入力電圧範囲: 最大 40V (HV バージョンは最大 60V)
- 必要な外付け部品はわずか 4 個
- 52kHz 固定周波数の内部発振器
- TTL シャットダウン機能、低消費電力のスタンバイ・モード
- 高効率
- 容易に入手可能な標準インダクタを使用
- WEBENCH<sup>®</sup> Power Designer により、LM76003 を使用するカスタム設計を作成

## 2 アプリケーション

- モーター・ドライブ
- 商用ネットワークとサーバーの PSU (電源)
- 家電製品
- 試験および計測機器

## 3 概要

LM2576 シリーズのレギュレータは、モノリシックな IC で、降圧型 (バック) スイッチング・レギュレータのすべてのアクティブ機能を提供し、優れたラインおよび負荷レギュレーションで 3A の負荷を駆動できます。3.3V、5V、12V、15V の固定出力電圧版と可変出力版があります。

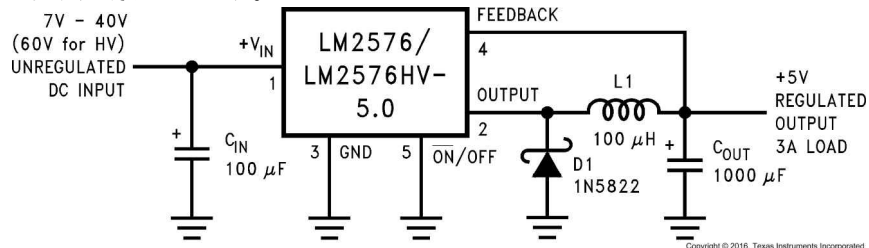

固定出力電圧バージョンの代表的なアプリケーションの図

これらのレギュレータは、必要な外部部品の数が最小限で、簡単に使用でき、フォールト保護と固定周波数発振器が内蔵されています。

LM2576 シリーズは、一般的な 3 端子のリニア・レギュレータを置き換えることができる高効率な製品です。これらの製品により、ヒート・シンクのサイズが大幅に減少し、条件によってはヒート・シンクが不要になります。

LM2576 とともに使用するため最適化された標準シリーズのインダクタがいくつかの製造元から入手可能です。このため、スイッチング電源の設計が大幅に簡素化されます。

その他の特長として、指定された入力電圧および出力負荷の条件において出力電圧の許容誤差が  $\pm 4\%$ 、発振器の周波数の許容誤差が  $\pm 10\%$  であることが挙げられます。外部シャットダウンが搭載されており、スタンバイ電流は  $50\mu\text{A}$  (標準値) です。出力スイッチにはサイクル単位の電流制限と、障害状態における完全な保護を行うためのサーマル・シャットダウンが含まれています。

LM76003 は、外付けコンポーネントがほとんど不要であり、EMI と熱性能のために簡単かつ最適に PCB をレイアウトできるようにピン配置が設計されています。仕様を比較するには、[デバイス比較表](#)を参照してください。

### パッケージ情報

部品番号	パッケージ <sup>(1)</sup>	本体サイズ (公称)
LM2576	KC (TO-220, 5)	10.16mm × 8.51mm
LM2576HV	KTT (DDPAK/ TO-263, 5)	10.16mm × 8.42mm

(1) 利用可能なパッケージについては、このデータシートの末尾にある注文情報を参照してください。

### 製品情報

部品番号	最大電源電圧 <sup>(1)</sup>
LM2576	40V
LM2576HV	60V

(1) [デバイス比較表](#)を参照してください。



## Table of Contents

<b>1 特長</b> .....	1	7.1 Overview.....	12
<b>2 アプリケーション</b> .....	1	7.2 Functional Block Diagram.....	12
<b>3 概要</b> .....	1	7.3 Feature Description.....	12
<b>4 Revision History</b> .....	2	7.4 Device Functional Modes.....	14
<b>5 Pin Configuration and Functions</b> .....	3	<b>8 Application and Implementation</b> .....	16
<b>6 Specifications</b> .....	4	8.1 Application Information.....	16
6.1 Absolute Maximum Ratings.....	4	8.2 Typical Applications.....	20
6.2 ESD Ratings.....	4	8.3 Power Supply Recommendations.....	26
6.3 Recommended Operating Conditions.....	4	8.4 Layout.....	26
6.4 Thermal Information.....	4	<b>9 Device and Documentation Support</b> .....	29
6.5 Electrical Characteristics: 3.3 V.....	5	9.1 Device Support.....	29
6.6 Electrical Characteristics: 5 V.....	5	9.2 Documentation Support.....	30
6.7 Electrical Characteristics: 12 V.....	5	9.3 サポート・リソース.....	30
6.8 Electrical Characteristics: 15 V.....	6	9.4 ドキュメントの更新通知を受け取る方法.....	30
6.9 Electrical Characteristics: Adjustable Output Voltage.....	6	9.5 Trademarks.....	30
6.10 Electrical Characteristics: All Output Voltage Versions.....	6	9.6 静電気放電に関する注意事項.....	31
6.11 Typical Characteristics.....	8	9.7 用語集.....	31
<b>7 Detailed Description</b> .....	12	<b>10 Mechanical, Packaging, and Orderable Information</b> .....	31

## 4 Revision History

資料番号末尾の英字は改訂を表しています。その改訂履歴は英語版に準じています。

<b>Changes from Revision F (May 2021) to Revision G (March 2023)</b>	<b>Page</b>
• LMR51430 および TLVM13630 製品フォルダの情報を追加.....	1
• 商標の情報を更新.....	1
• デバイス情報表のフォーマットを更新.....	1
• Updated trademark information.....	16
<b>Changes from Revision E (June 2020) to Revision F (May 2021)</b>	<b>Page</b>
• LM76003 の販売促進のための情報を追加.....	1
• 文書全体にわたって表、図、相互参照の採番方法を更新.....	1
<b>Changes from Revision D (January 2016) to Revision E (June 2020)</b>	<b>Page</b>
• LMR33630 に関する情報を追加.....	1
<b>Changes from Revision C (April 2013) to Revision D (January 2016)</b>	<b>Page</b>
• 「ESD 定格」表、「機能説明」セクション、「デバイスの機能モード」セクション、「アプリケーションと実装」セクション、「電源に関する推奨事項」セクション、「レイアウト」セクション、「デバイスおよびドキュメントのサポート」セクション、「メカニカル、パッケージ、および注文情報」セクションを追加.....	1
• Moved the thermal resistance data from the <i>Electrical Characteristics: All Output Voltage Versions</i> table to the <i>Thermal Information</i> table.....	4
<b>Changes from Revision B (April 2013) to Revision C (April 2013)</b>	<b>Page</b>
• Changed layout of National Data Sheet to TI format.....	3

## 5 Pin Configuration and Functions

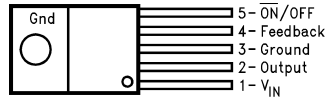

☒ 5-1. KC Package 5-Pin TO-220 Top View

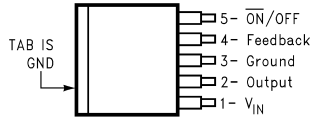

Side View

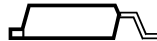

☒ 5-2. KTT Package 5-PIN DDPAK/TO-263 Top View

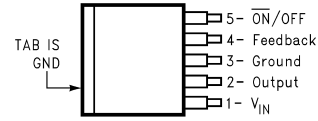

Side View

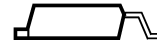

☒ 5-3. DDPAK/TO-263 (S) Package 5-Lead Surface-Mount Package Top View

表 5-1. Pin Functions

PIN		I/O <sup>(1)</sup>	DESCRIPTION
NO.	NAME		
1	V <sub>IN</sub>	I	Supply input pin to collector pin of high-side transistor. Connect to power supply and input bypass capacitors C <sub>IN</sub> . Path from V <sub>IN</sub> pin to high frequency bypass C <sub>IN</sub> and GND must be as short as possible.
2	OUTPUT	O	Emitter pin of the power transistor. This is a switching node. Attached this pin to an inductor and the cathode of the external diode.
3	GROUND	—	Ground pin. Path to C <sub>IN</sub> must be as short as possible.
4	FEEDBACK	I	Feedback sense input pin. Connect to the midpoint of feedback divider to set V <sub>OUT</sub> for ADJ version or connect this pin directly to the output capacitor for a fixed output version.
5	ON/OFF	I	Enable input to the voltage regulator. High = OFF and low = ON. Connect to GND to enable the voltage regulator. Do not leave this pin float.
—	TAB	—	Connected to GND. Attached to heatsink for thermal relief for TO-220 package or put a copper plane connected to this pin as a thermal relief for DDPAK package.

(1) I = INPUT, O = OUTPUT

## 6 Specifications

### 6.1 Absolute Maximum Ratings

over the recommended operating junction temperature range of -40°C to 125°C (unless otherwise noted)<sup>(1) (2)</sup>

		MIN	MAX	UNIT
Maximum supply voltage	LM2576		45	V
	LM2576HV		63	
ON /OFF pin input voltage		$-0.3V \leq V \leq +V_{IN}$		V
Output voltage to ground	(Steady-state)	-1		V
Power dissipation		Internally Limited		
Maximum junction temperature, T <sub>J</sub>			150	°C
Storage temperature, T <sub>stg</sub>		-65	150	°C

- (1) Stresses beyond those listed under *Absolute Maximum Ratings* may cause permanent damage to the device. These are stress ratings only, which do not imply functional operation of the device at these or any other conditions beyond those indicated under *Recommended Operating Conditions*. Exposure to absolute-maximum-rated conditions for extended periods may affect device reliability.
- (2) If Military/Aerospace specified devices are required, please contact the TI Sales Office/ Distributors for availability and specifications.

### 6.2 ESD Ratings

			VALUE	UNIT
V <sub>(ESD)</sub>	Electrostatic discharge	Human-body model (HBM), per ANSI/ESDA/JEDEC JS-001 <sup>(1)</sup>	±2000	V

- (1) JEDEC document JEP155 states that 500-V HBM allows safe manufacturing with a standard ESD control process.

### 6.3 Recommended Operating Conditions

over the recommended operating junction temperature range of -40°C to 125°C (unless otherwise noted)

		MIN	MAX	UNIT
Temperature	LM2576, LM2576HV	-40	125	°C
Supply voltage	LM2576		40	V
	LM2576HV		60	

### 6.4 Thermal Information

THERMAL METRIC <sup>(1) (2) (3)</sup>		LM2576, LM2576HV		UNIT
		KTT (TO-263)	KC (TO-220)	
		5 PINS	5 PINS	
R <sub>θJA</sub>	Junction-to-ambient thermal resistance	42.6	32.4	°C/W
R <sub>θJC(top)</sub>	Junction-to-case (top) thermal resistance	43.3	41.2	°C/W
R <sub>θJB</sub>	Junction-to-board thermal resistance	22.4	17.6	°C/W
Ψ <sub>JT</sub>	Junction-to-top characterization parameter	10.7	7.8	°C/W
Ψ <sub>JB</sub>	Junction-to-board characterization parameter	21.3	17	°C/W
R <sub>θJC(bot)</sub>	Junction-to-case (bottom) thermal resistance	0.4	0.4	°C/W

- (1) For more information about traditional and new thermal metrics, see the *Semiconductor and IC Package Thermal Metrics* application report, [SPRA953](#) and the *Using New Thermal Metrics* applications report, [SBVA025](#).
- (2) The package thermal impedance is calculated in accordance with JESD 51-7
- (3) Thermal Resistances were simulated on a 4-layer, JEDEC board.

## 6.5 Electrical Characteristics: 3.3 V

Specifications are for  $T_J = 25^\circ\text{C}$  (unless otherwise noted).

PARAMETER		TEST CONDITIONS		MIN	TYP	MAX	UNIT
<b>SYSTEM PARAMETERS TEST CIRCUIT</b> <a href="#">8-3</a> and <a href="#">8-9</a> <sup>(1)</sup>							
$V_{OUT}$	Output Voltage	$V_{IN} = 12\text{ V}$ , $I_{LOAD} = 0.5\text{ A}$ Circuit of <a href="#">8-3</a> and <a href="#">8-9</a>		3.234	3.3	3.366	V
	Output Voltage: LM2576	$6\text{ V} \leq V_{IN} \leq 40\text{ V}$ , $0.5\text{ A} \leq I_{LOAD} \leq 3\text{ A}$ Circuit of <a href="#">8-3</a> and <a href="#">8-9</a>	$T_J = 25^\circ\text{C}$ Applies over full operating temperature range	3.168	3.3	3.432	V
	Output Voltage: LM2576HV	$6\text{ V} \leq V_{IN} \leq 60\text{ V}$ , $0.5\text{ A} \leq I_{LOAD} \leq 3\text{ A}$ Circuit of <a href="#">8-3</a> and <a href="#">8-9</a>	$T_J = 25^\circ\text{C}$ Applies over full operating temperature range	3.168	3.3	3.45	
$\eta$	Efficiency	$V_{IN} = 12\text{ V}$ , $I_{LOAD} = 3\text{ A}$		75%			

(1) External components such as the catch diode, inductor, input and output capacitors can affect switching regulator system performance. When the LM2576/LM2576HV is used as shown in [8-3](#) and [8-9](#), system performance is as shown in [セクション 6.10](#).

## 6.6 Electrical Characteristics: 5 V

Specifications are for  $T_J = 25^\circ\text{C}$  for the [8-3](#) and [8-9](#) (unless otherwise noted).

PARAMETER		TEST CONDITIONS		MIN	TYP	MAX	UNIT
<b>SYSTEM PARAMETERS TEST CIRCUIT</b> <a href="#">8-3</a> and <a href="#">8-9</a> <sup>(1)</sup>							
$V_{OUT}$	Output Voltage	$V_{IN} = 12\text{ V}$ , $I_{LOAD} = 0.5\text{ A}$ Circuit of <a href="#">8-3</a> and <a href="#">8-9</a>		4.9	5	5.1	V
$V_{OUT}$	Output Voltage LM2576	$0.5\text{ A} \leq I_{LOAD} \leq 3\text{ A}$ , $8\text{ V} \leq V_{IN} \leq 40\text{ V}$ Circuit of <a href="#">8-3</a> and <a href="#">8-9</a>	$T_J = 25^\circ\text{C}$	4.8	5	5.2	V
			Applies over full operating temperature range	4.75		5.25	
$V_{OUT}$	Output Voltage LM2576HV	$0.5\text{ A} \leq I_{LOAD} \leq 3\text{ A}$ , $8\text{ V} \leq V_{IN} \leq 60\text{ V}$ Circuit of <a href="#">8-3</a> and <a href="#">8-9</a>	$T_J = 25^\circ\text{C}$	4.8	5	4.75	V
			Applies over full operating temperature range	5.225		5.275	
$\eta$	Efficiency	$V_{IN} = 12\text{ V}$ , $I_{LOAD} = 3\text{ A}$		77%			

(1) External components such as the catch diode, inductor, input and output capacitors can affect switching regulator system performance. When the LM2576/LM2576HV is used as shown in [8-3](#) and [8-9](#), system performance is as shown in [セクション 6.10](#).

## 6.7 Electrical Characteristics: 12 V

Specifications are for  $T_J = 25^\circ\text{C}$  (unless otherwise noted).

PARAMETER		TEST CONDITIONS		MIN	TYP	MAX	UNIT
<b>SYSTEM PARAMETERS TEST CIRCUIT</b> <a href="#">8-3</a> and <a href="#">8-9</a> <sup>(1)</sup>							
$V_{OUT}$	Output Voltage	$V_{IN} = 25\text{ V}$ , $I_{LOAD} = 0.5\text{ A}$ Circuit of <a href="#">8-3</a> and <a href="#">8-9</a>		11.76	12	12.24	V
$V_{OUT}$	Output Voltage LM2576	$0.5\text{ A} \leq I_{LOAD} \leq 3\text{ A}$ , $15\text{ V} \leq V_{IN} \leq 40\text{ V}$ Circuit of <a href="#">8-3</a> and <a href="#">8-9</a> and	$T_J = 25^\circ\text{C}$	11.52	12	12.48	V
			Applies over full operating temperature range	11.4		12.6	
$V_{OUT}$	Output Voltage LM2576HV	$0.5\text{ A} \leq I_{LOAD} \leq 3\text{ A}$ , $15\text{ V} \leq V_{IN} \leq 60\text{ V}$ Circuit of <a href="#">8-3</a> and <a href="#">8-9</a>	$T_J = 25^\circ\text{C}$	11.52	12	12.54	V
			Applies over full operating temperature range	11.4		12.66	

**LM2576, LM2576HV**

JAJ5782G – JUNE 1999 – REVISED MARCH 2023

 Specifications are for  $T_J = 25^\circ\text{C}$  (unless otherwise noted).

PARAMETER	TEST CONDITIONS	MIN	TYP	MAX	UNIT
$\eta$ Efficiency	$V_{IN} = 15\text{ V}$ , $I_{LOAD} = 3\text{ A}$		88%		

- (1) External components such as the catch diode, inductor, input and output capacitors can affect switching regulator system performance. When the LM2576/LM2576HV is used as shown in [Figure 8-3](#) and [Figure 8-9](#), system performance is as shown in [Section 6.10](#).

## 6.8 Electrical Characteristics: 15 V

over operating free-air temperature range (unless otherwise noted).

PARAMETER	TEST CONDITIONS	MIN	TYP	MAX	UNIT
<b>SYSTEM PARAMETERS TEST CIRCUIT</b> <a href="#">Figure 8-3</a> and <a href="#">Figure 8-9</a> <sup>(1)</sup>					
$V_{OUT}$ Output Voltage	$V_{IN} = 25\text{ V}$ , $I_{LOAD} = 0.5\text{ A}$ Circuit of <a href="#">Figure 8-3</a> and <a href="#">Figure 8-9</a>	14.7	15	15.3	V
$V_{OUT}$ Output Voltage LM2576	$0.5\text{ A} \leq I_{LOAD} \leq 3\text{ A}$ , $18\text{ V} \leq V_{IN} \leq 40\text{ V}$ Circuit of <a href="#">Figure 8-3</a> and <a href="#">Figure 8-9</a>	$T_J = 25^\circ\text{C}$ Applies over full operating temperature range	14.4 14.25	15 15.75	V
$V_{OUT}$ Output Voltage LM2576HV	$0.5\text{ A} \leq I_{LOAD} \leq 3\text{ A}$ , $18\text{ V} \leq V_{IN} \leq 60\text{ V}$ Circuit of <a href="#">Figure 8-3</a> and <a href="#">Figure 8-9</a>	$T_J = 25^\circ\text{C}$ Applies over full operating temperature range	14.4 15.68	15 15.83	V
$\eta$ Efficiency	$V_{IN} = 18\text{ V}$ , $I_{LOAD} = 3\text{ A}$		88%		

- (1) External components such as the catch diode, inductor, input and output capacitors can affect switching regulator system performance. When the LM2576/LM2576HV is used as shown in [Figure 8-3](#) and [Figure 8-9](#), system performance is as shown in [Section 6.10](#).

## 6.9 Electrical Characteristics: Adjustable Output Voltage

over operating free-air temperature range (unless otherwise noted).

PARAMETER	TEST CONDITIONS	MIN	TYP	MAX	UNIT
<b>SYSTEM PARAMETERS TEST CIRCUIT</b> <a href="#">Figure 8-3</a> and <a href="#">Figure 8-9</a> <sup>(1)</sup>					
$V_{OUT}$ Feedback voltage	$V_{IN} = 12\text{ V}$ , $I_{LOAD} = 0.5\text{ A}$ $V_{OUT} = 5\text{ V}$ , Circuit of <a href="#">Figure 8-3</a> and <a href="#">Figure 8-9</a>	1.217	1.23	1.243	V
$V_{OUT}$ Feedback Voltage LM2576	$0.5\text{ A} \leq I_{LOAD} \leq 3\text{ A}$ , $8\text{ V} \leq V_{IN} \leq 40\text{ V}$ $V_{OUT} = 5\text{ V}$ , Circuit of <a href="#">Figure 8-3</a> and <a href="#">Figure 8-9</a>	$T_J = 25^\circ\text{C}$ Applies over full operating temperature range	1.193 1.18	1.23 1.28	V
$V_{OUT}$ Feedback Voltage LM2576HV	$0.5\text{ A} \leq I_{LOAD} \leq 3\text{ A}$ , $8\text{ V} \leq V_{IN} \leq 60\text{ V}$ $V_{OUT} = 5\text{ V}$ , Circuit of <a href="#">Figure 8-3</a> and <a href="#">Figure 8-9</a>	$T_J = 25^\circ\text{C}$ Applies over full operating temperature range	1.193 1.18	1.23 1.286	V
$\eta$ Efficiency	$V_{IN} = 12\text{ V}$ , $I_{LOAD} = 3\text{ A}$ , $V_{OUT} = 5\text{ V}$		77%		



- (1) External components such as the catch diode, inductor, input and output capacitors can affect switching regulator system performance. When the LM2576/LM2576HV is used as shown in [Figure 8-3](#) and [Figure 8-9](#), system performance is as shown in [Section 6.10](#).



## 6.10 Electrical Characteristics: All Output Voltage Versions

over operating free-air temperature range (unless otherwise noted)

PARAMETER	TEST CONDITIONS	MIN	TYP <sup>(1)</sup>	MAX	UNIT
<b>SYSTEM PARAMETERS TEST CIRCUIT</b> <a href="#">Figure 8-3</a> and <a href="#">Figure 8-9</a> <sup>(2)</sup>					
$I_b$ Feedback Bias Current	$V_{OUT} = 5\text{ V}$ (Adjustable Version Only)	$T_J = 25^\circ\text{C}$ Applies over full operating temperature range	100 500	50	nA

over operating free-air temperature range (unless otherwise noted)

PARAMETER		TEST CONDITIONS		MIN	TYP <sup>(1)</sup>	MAX	UNIT
f <sub>O</sub>	Oscillator Frequency <sup>(7)</sup>	T <sub>J</sub> = 25°C		47	52	58	kHz
		Applies over full operating temperature range		42		63	
V <sub>SAT</sub>	Saturation Voltage	I <sub>OUT</sub> = 3 A <sup>(3)</sup>	T <sub>J</sub> = 25°C		1.4	1.8	V
			Applies over full operating temperature range			2	
DC	Max Duty Cycle (ON) <sup>(4)</sup>			93%	98%		
I <sub>CL</sub>	Current Limit <sup>(3) (7)</sup>	T <sub>J</sub> = 25°C		4.2	5.8	6.9	A
		Applies over full operating temperature range		3.5		7.5	
I <sub>L</sub>	Output Leakage Current	Output = 0 V Output = -1 V Output = -1 V <sup>(5) (6)</sup>		2	7.5	30	mA
I <sub>Q</sub>	Quiescent Current <sup>(5)</sup>				5	10	mA
I <sub>STBY</sub>	Standby Quiescent Current	ON /OFF Pin = 5 V (OFF)			50	200	μA
<b>ON /OFF CONTROL TEST CIRCUIT</b>  <b>8-3</b> and  <b>8-9</b>							
V <sub>IH</sub>	ON /OFF Pin Logic Input Level	V <sub>OUT</sub> = 0 V	T <sub>J</sub> = 25°C	2.2	1.4		V
			Applies over full operating temperature range		2.4		
V <sub>IL</sub>	ON /OFF Pin Logic Input Level	V <sub>OUT</sub> = Nominal Output Voltage	T <sub>J</sub> = 25°C		1.2	1	V
			Applies over full operating temperature range			0.8	
I <sub>IH</sub>	ON /OFF Pin Input Current	ON /OFF Pin = 5 V (OFF)			12	30	μA
I <sub>IL</sub>	ON /OFF Pin Input Current	ON /OFF Pin = 0 V (ON)			0	10	μA

- (1) All limits specified at room temperature (25°C) unless otherwise noted. All room temperature limits are 100% production tested. All limits at temperature extremes are specified through correlation using standard Statistical Quality Control (SQC) methods.
- (2) External components such as the catch diode, inductor, input and output capacitors can affect switching regulator system performance. When the LM2576/LM2576HV is used as shown in  **8-3** and  **8-9**, system performance is as shown in [セクション 6.10](#).
- (3) Output pin sourcing current. No diode, inductor or capacitor connected to output.
- (4) Feedback pin removed from output and connected to 0V.
- (5) Feedback pin removed from output and connected to +12 V for the Adjustable, 3.3-V, and 5-V versions, and +25 V for the 12-V and 15-V versions, to force the output transistor OFF.
- (6) V<sub>IN</sub> = 40 V (60 V for high voltage version).
- (7) The oscillator frequency reduces to approximately 11 kHz in the event of an output short or an overload which causes the regulated output voltage to drop approximately 40% from the nominal output voltage. This self protection feature lowers the average power dissipation of the IC by lowering the minimum duty cycle from 5% down to approximately 2%.

## 6.11 Typical Characteristics

(Circuit of  8-3 and  8-9)

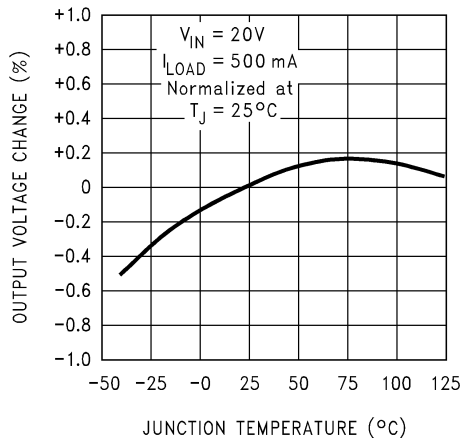

 **6-1. Normalized Output Voltage**

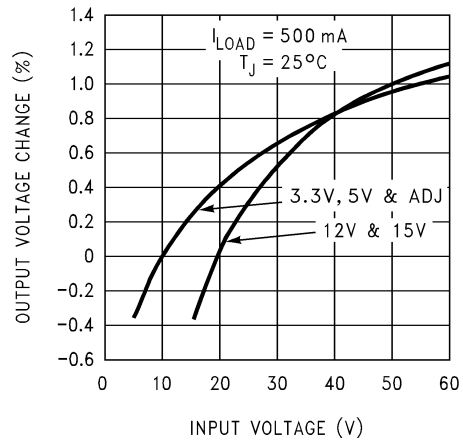

 **6-2. Line Regulation**

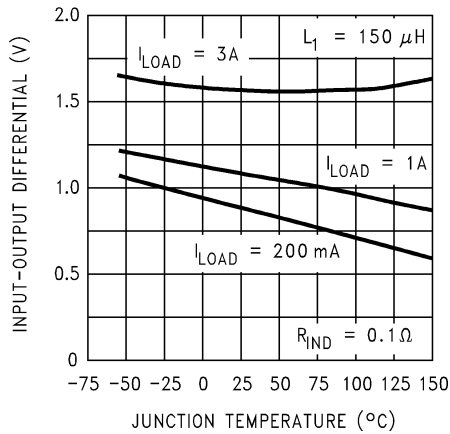

 **6-3. Dropout Voltage**

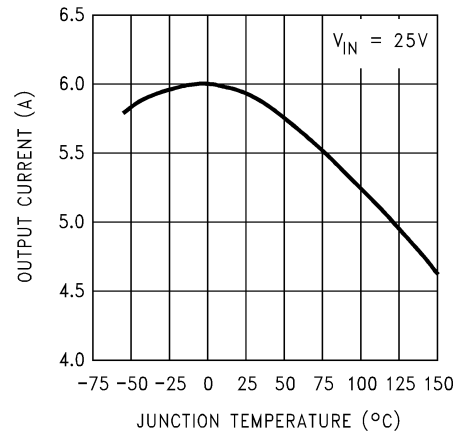

 **6-4. Current Limit**

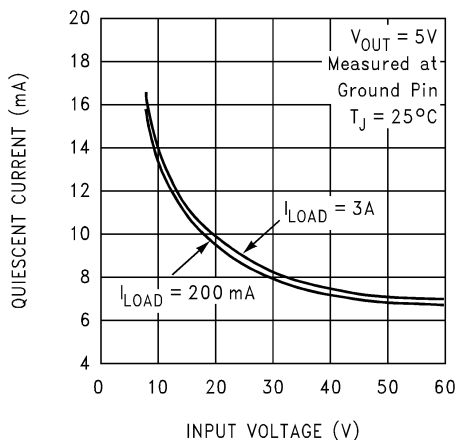

 **6-5. Quiescent Current**

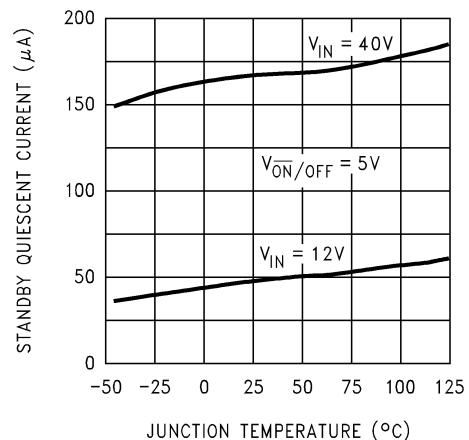

 **6-6. Standby Quiescent Current**



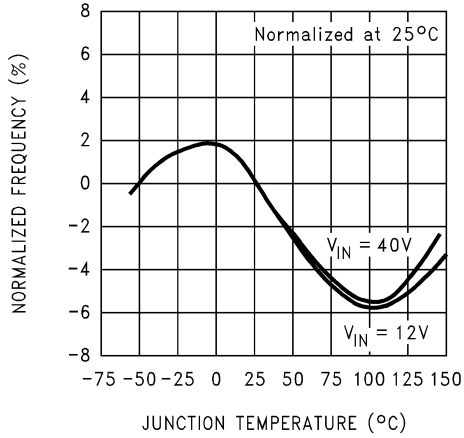

6-7. Oscillator Frequency

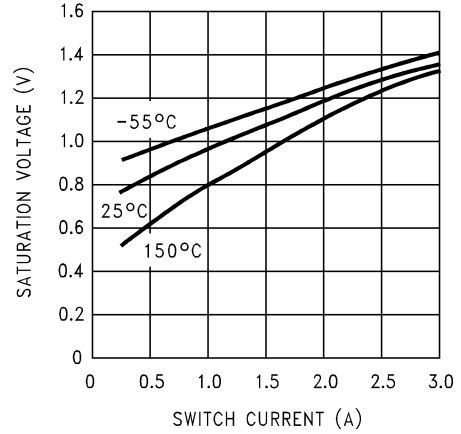

6-8. Switch Saturation Voltage

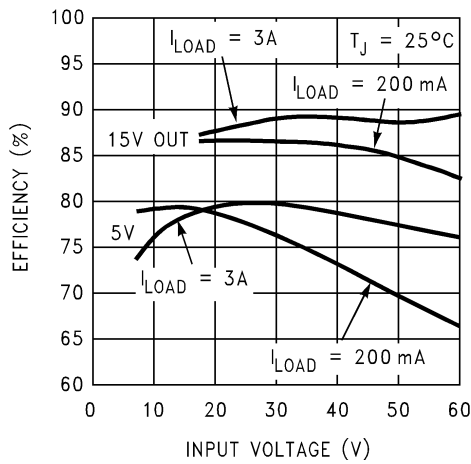

6-9. Efficiency

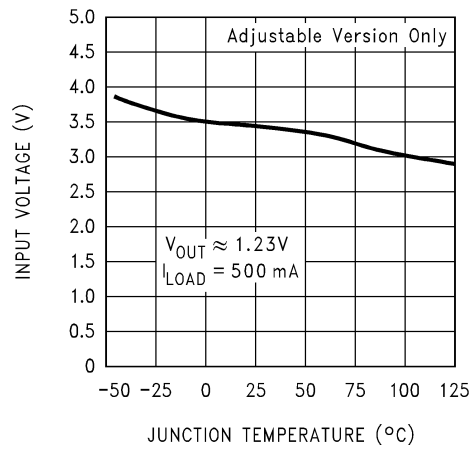

6-10. Minimum Operating Voltage

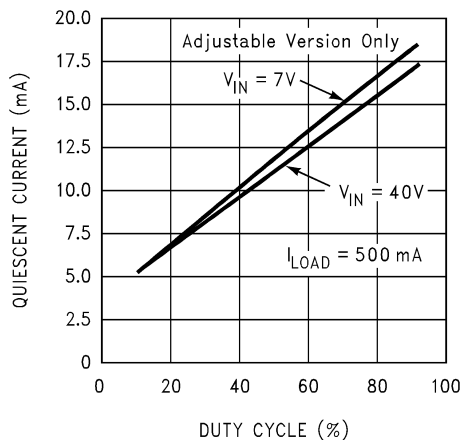

6-11. Quiescent Current vs Duty Cycle

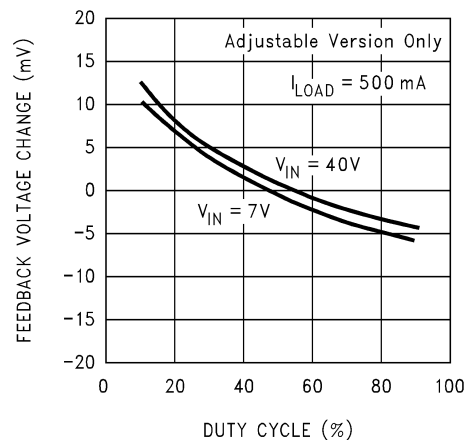

6-12. Feedback Voltage vs Duty Cycle

**LM2576, LM2576HV**

JAJS782G – JUNE 1999 – REVISED MARCH 2023

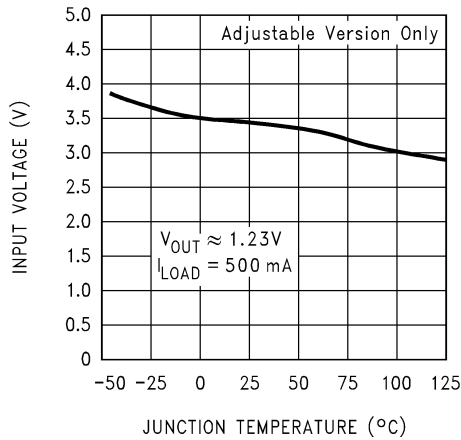

**6-13. Minimum Operating Voltage**

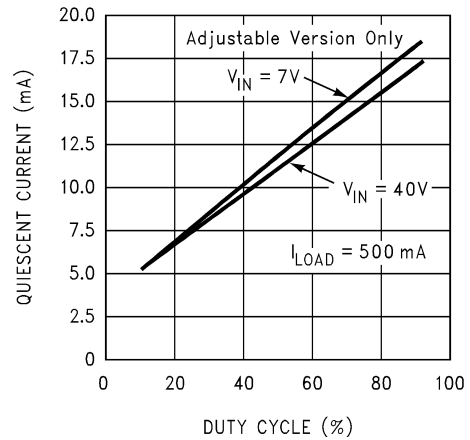

**6-14. Quiescent Current vs Duty Cycle**

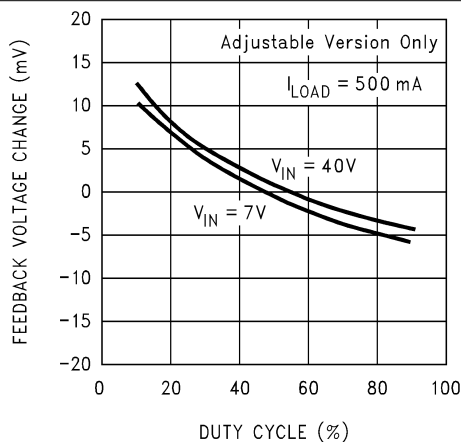

**6-15. Feedback Voltage vs Duty Cycle**

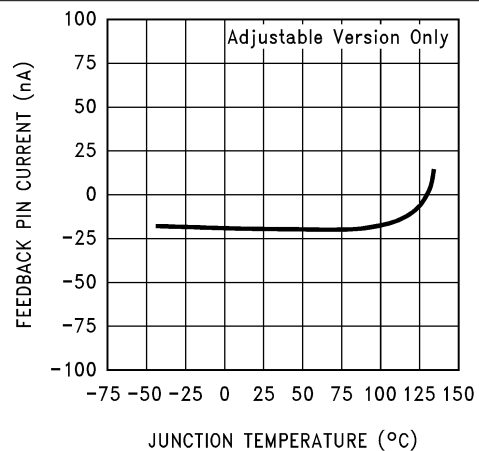

**6-16. Feedback Pin Current**

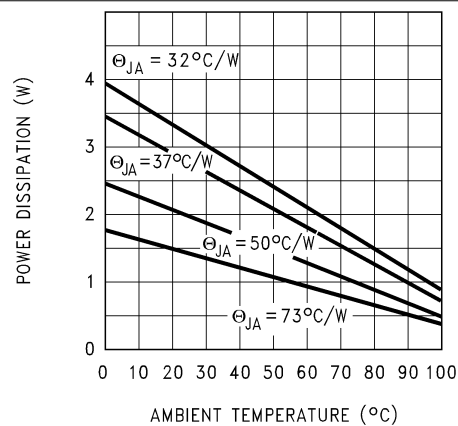

If the DDPAK/TO-263 package is used, the thermal resistance can be reduced by increasing the PCB copper area thermally connected to the package. Using 0.5 square inches of copper area,  $\theta_{JA}$  is 50°C/W, with 1 square inch of copper area,  $\theta_{JA}$  is 37°C/W, and with 1.6 or more square inches of copper area,  $\theta_{JA}$  is 32°C/W.

**6-17. Maximum Power Dissipation (DDPAK/TO-263)**

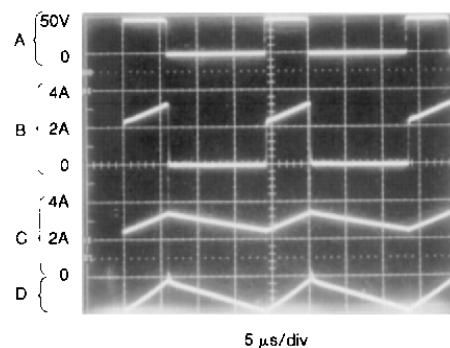

$V_{OUT} = 15\text{ V}$  A: Output Pin Voltage, 50 V/div B: Output Pin Current, 2 A/div C: Inductor Current, 2 A/div D: Output Ripple Voltage, 50 mV/div, AC-Coupled  
**Horizontal Time Base: 5 µs/div**

**6-18. Switching Waveforms**

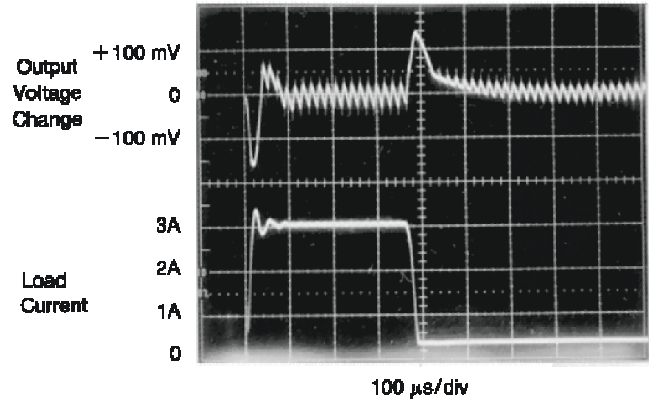

☒ 6-19. Load Transient Response

## 7 Detailed Description

### 7.1 Overview

The LM2576 SIMPLE SWITCHER® power converter regulator is an easy-to-use, non-synchronous step-down DC-DC converter with a wide input voltage range from 40 V to up to 60 V for a HV version. It is capable of delivering up to 3-A DC load current with excellent line and load regulation. These devices are available in fixed output voltages of 3.3 V, 5 V, 12 V, 15 V, and an adjustable output version. The family requires few external components, and the pin arrangement was designed for simple, optimum PCB layout.

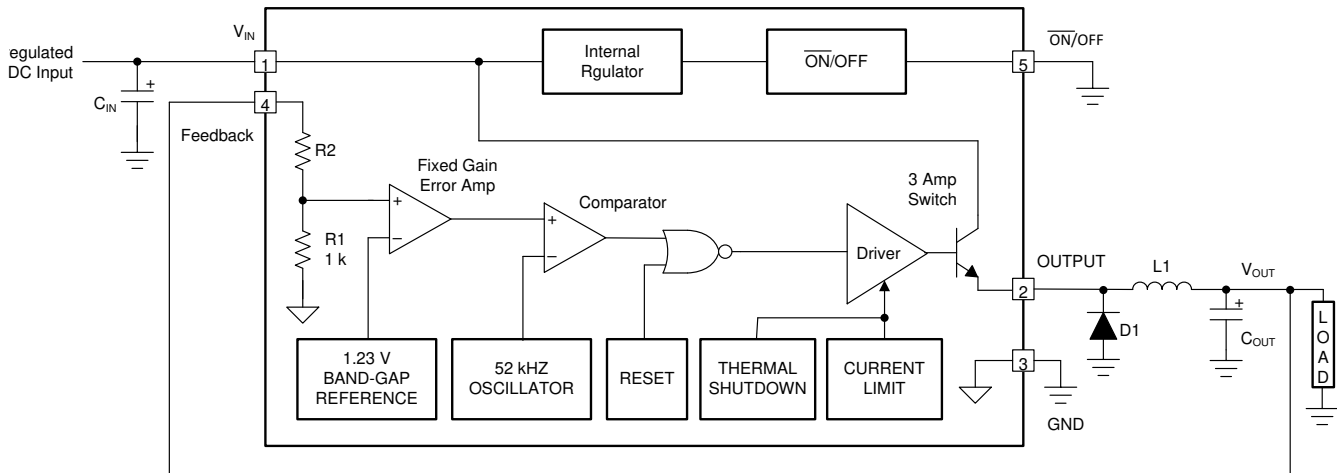

### 7.2 Functional Block Diagram



3.3 V R2 = 1.7 k 5 V, R2 = 3.1 k 12 V, R2 = 8.84 k 15 V, R2 = 11.3 k For ADJ. Version R1 = Open, R2 = 0 Ω Patent Pending

### 7.3 Feature Description

#### 7.3.1 Undervoltage Lockout

In some applications it is desirable to keep the regulator off until the input voltage reaches a certain threshold.  7-1 shows an undervoltage lockout circuit that accomplishes this task, while  7-2 shows the same circuit applied to a buck-boost configuration. These circuits keep the regulator off until the input voltage reaches a predetermined level.

$$V_{TH} \approx V_{Z1} + 2V_{BE}(Q1) \tag{1}$$

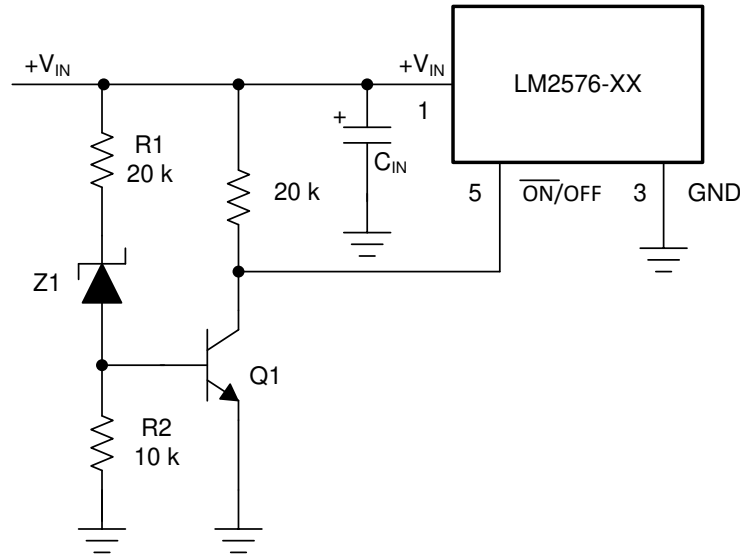

Complete circuit not shown.

**7-1. Undervoltage Lockout for Buck Circuit**

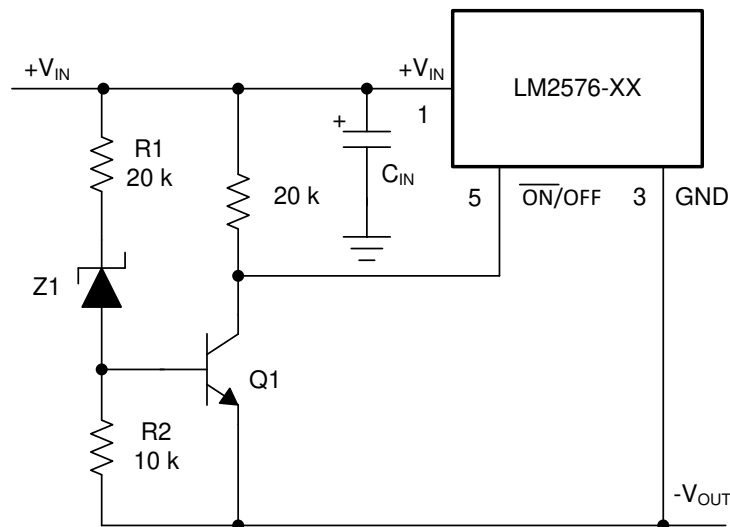

Complete circuit not shown (see [7-1](#)).

**7-2. Undervoltage Lockout for Buck-Boost Circuit**

### 7.3.2 Delayed Start-Up

The  $\overline{\text{ON}}/\text{OFF}$  pin can be used to provide a delayed start-up feature as shown in [7-3](#). With an input voltage of 20 V and for the part values shown, the circuit provides approximately 10 ms of delay time before the circuit begins switching. Increasing the RC time constant can provide longer delay times. But excessively large RC time constants can cause problems with input voltages that are high in 60-Hz or 120-Hz ripple, by coupling the ripple into the  $\overline{\text{ON}}/\text{OFF}$  pin.

### 7.3.3 Adjustable Output, Low-Ripple Power Supply

[7-4](#) shows a 3-A power supply that features an adjustable output voltage. An additional LC filter that reduces the output ripple by a factor of 10 or more is included in this circuit.

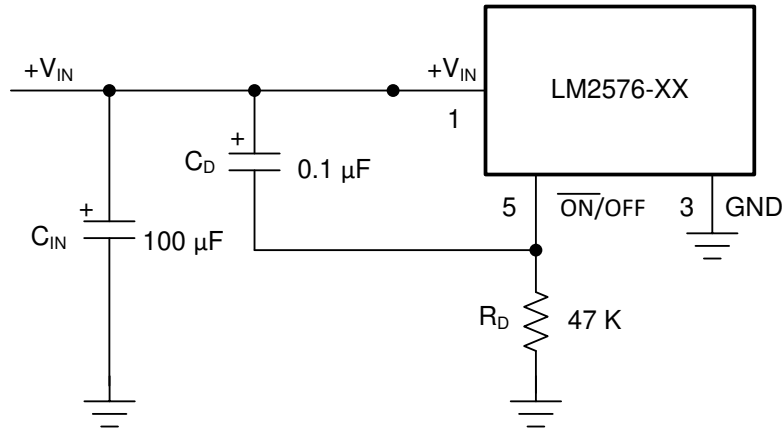

Complete circuit not shown.

图 7-3. Delayed Start-Up



图 7-4. 1.2-V to 55-V Adjustable 3-A Power Supply With Low Output Ripple

## 7.4 Device Functional Modes

### 7.4.1 Shutdown Mode

The  $\overline{\text{ON/OFF}}$  pin provides electrical ON and OFF control for the LM2576. When the voltage of this pin is higher than 1.4 V, the device is in shutdown mode. The typical standby current in this mode is 50  $\mu\text{A}$ .

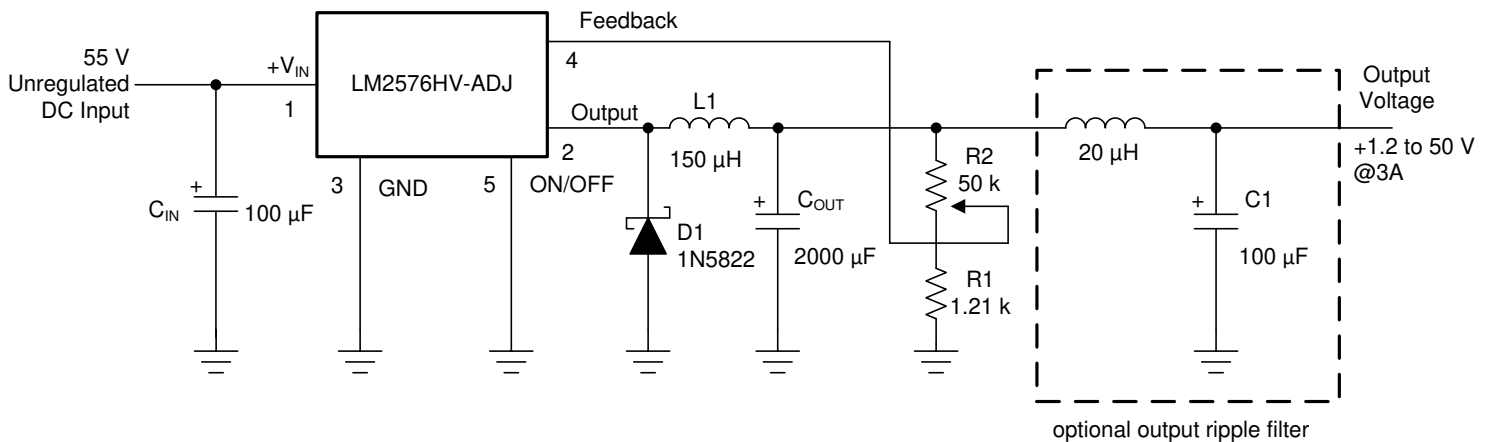
### 7.4.2 Active Mode

When the voltage of the  $\overline{\text{ON/OFF}}$  pin is below 1.2 V, the device starts switching, and the output voltage rises until it reaches the normal regulation voltage.

### 7.4.3 Current Limit

The LM2576 device has current limiting to prevent the switch current from exceeding safe values during an accidental overload on the output. This current limit value can be found in [セクション 6.10](#) under the heading of  $I_{\text{CL}}$ .

The LM2576 uses cycle-by-cycle peak current limit for overload protection. This helps to prevent damage to the device and external components. The regulator operates in current limit mode whenever the inductor current exceeds the value of  $I_{\text{CL}}$  given in [セクション 6.10](#). This occurs if the load current is greater than 3 A, or the converter is starting up. Keep in mind that the maximum available load current depends on the input voltage, output voltage, and inductor value. The regulator also incorporates short-circuit protection to prevent inductor current run-away. When the voltage on the FB pin (ADJ) falls below about 0.58 V the switching frequency is

dropped to about 11 kHz. This allows the inductor current to ramp down sufficiently during the switch OFF-time to prevent saturation.

## 8 Application and Implementation

注

Information in the following applications sections is not part of the TI component specification, and TI does not warrant its accuracy or completeness. TI's customers are responsible for determining suitability of components for their purposes, as well as validating and testing their design implementation to confirm system functionality.

### 8.1 Application Information

#### 8.1.1 Input Capacitor (C<sub>IN</sub>)

To maintain stability, the regulator input pin must be bypassed with at least a 100-μF electrolytic capacitor. The capacitor leads must be kept short, and placed near the regulator.

If the operating temperature range includes temperatures below –25°C, the input capacitor value can need to be larger. With most electrolytic capacitors, the capacitance value decreases and the ESR increases with lower temperatures and age. Paralleling a ceramic or solid tantalum capacitor increases the regulator stability at cold temperatures. For maximum capacitor operating lifetime, the RMS ripple current rating of the capacitor must be greater than:

$$1.2\left(\frac{t_{\text{ON}}}{T}\right)(I_{\text{LOAD}}) \quad (2)$$

Where for a buck regulator:

$$\frac{t_{\text{ON}}}{T} = \frac{V_{\text{OUT}}}{V_{\text{IN}}} \quad (3)$$

Where for a buck-boost regulator:

$$\frac{t_{\text{ON}}}{T} = \frac{|V_{\text{OUT}}|}{|V_{\text{OUT}}| + V_{\text{IN}}} \quad (4)$$

#### 8.1.2 Inductor Selection

All switching regulators have two basic modes of operation: continuous and discontinuous. The difference between the two types relates to the inductor current, whether it is flowing continuously, or if it drops to zero for a period of time in the normal switching cycle. Each mode has distinctively different operating characteristics, which can affect the regulator performance and requirements.

The LM2576 (or any of the SIMPLE SWITCHER power converter family) can be used for both continuous and discontinuous modes of operation.

The inductor value selection guides in [☒ 8-4](#) through [☒ 8-8](#) are designed for buck regulator designs of the continuous inductor current type. When using inductor values shown in the inductor selection guide, the peak-to-peak inductor ripple current is approximately 20% to 30% of the maximum DC current. With relatively heavy load currents, the circuit operates in the continuous mode (inductor current always flowing), but under light load conditions, the circuit is forced to the discontinuous mode (inductor current falls to zero for a period of time). This discontinuous mode of operation is perfectly acceptable. For light loads (less than approximately 300 mA), it can be desirable to operate the regulator in the discontinuous mode, primarily because of the lower inductor values required for the discontinuous mode.

The selection guide chooses inductor values suitable for continuous mode operation, but if the inductor value chosen is prohibitively high, the designer must investigate the possibility of discontinuous operation.

Inductors are available in different styles such as pot core, toroid, E-frame, bobbin core, and so on, as well as different core materials, such as ferrites and powdered iron. The bobbin core is the least expensive type, and consists of wire wrapped on a ferrite rod core. This type of construction makes for an inexpensive inductor;



however, because the magnetic flux is not completely contained within the core, the bobbin core generates more electromagnetic interference (EMI). This EMI can cause problems in sensitive circuits, or can give incorrect scope readings because of induced voltages in the scope probe.

The inductors listed in the selection chart include ferrite pot core construction for AIE, powdered iron toroid for Pulse Engineering, and ferrite bobbin core for Renco.

An inductor must not operate beyond its maximum-rated current because it can saturate. When an inductor begins to saturate, the inductance decreases rapidly, and the inductor begins to look mainly resistive (the DC resistance of the winding), causing the switch current to rise very rapidly. Different inductor types have different saturation characteristics, and this must be considered when selecting an inductor.

The inductor manufacturer's data sheets include current and energy limits to avoid inductor saturation.

### 8.1.3 Inductor Ripple Current

When the switcher is operating in the continuous mode, the inductor current waveform ranges from a triangular to a sawtooth type of waveform (depending on the input voltage). For a given input voltage and output voltage, the peak-to-peak amplitude of this inductor current waveform remains constant. As the load current rises or falls, the entire sawtooth current waveform also rises or falls. The average DC value of this waveform is equal to the DC load current (in the buck regulator configuration).

If the load current drops to a low enough level, the bottom of the sawtooth current waveform reaches zero, and the switcher changes to a discontinuous mode of operation. This is a perfectly acceptable mode of operation. Any buck switching regulator (no matter how large the inductor value is) is forced to run discontinuous if the load current is light enough.

### 8.1.4 Output Capacitor

An output capacitor is required to filter the output voltage and is needed for loop stability. The capacitor must be placed near the LM2576 using short PCB traces. Standard aluminum electrolytics are usually adequate, but TI recommends low ESR types for low output ripple voltage and good stability. The ESR of a capacitor depends on many factors, including: the value, the voltage rating, physical size, and the type of construction. In general, low value or low voltage (less than 12 V) electrolytic capacitors usually have higher ESR numbers.

The amount of output ripple voltage is primarily a function of the ESR (Equivalent Series Resistance) of the output capacitor and the amplitude of the inductor ripple current ( $\Delta I_{IND}$ ). See [セクション 8.1.3](#).

The lower capacitor values (220  $\mu$ F to 1000  $\mu$ F) allows typically 50 mV to 150 mV of output ripple voltage, while larger-value capacitors reduces the ripple to approximately 20 mV to 50 mV.

$$\text{Output Ripple Voltage} = (\Delta I_{IND}) (\text{ESR of } C_{OUT}) \quad (5)$$

To further reduce the output ripple voltage, several standard electrolytic capacitors can be paralleled, or a higher-grade capacitor can be used. Such capacitors are often called *high-frequency*, *low-inductance*, or *low-ESR*. These reduces the output ripple to 10 mV or 20 mV. However, when operating in the continuous mode, reducing the ESR below 0.03  $\Omega$  can cause instability in the regulator.

Tantalum capacitors can have a very low ESR, and must be carefully evaluated if it is the only output capacitor. Because of their good low temperature characteristics, a tantalum can be used in parallel with aluminum electrolytics, with the tantalum making up 10% or 20% of the total capacitance.

The ripple current rating of the capacitor at 52 kHz must be at least 50% higher than the peak-to-peak inductor ripple current.

### 8.1.5 Catch Diode

Buck regulators require a diode to provide a return path for the inductor current when the switch is off. This diode must be placed close to the LM2576 using short leads and short printed-circuit traces.

Because of their fast switching speed and low forward voltage drop, Schottky diodes provide the best efficiency, especially in low output voltage switching regulators (less than 5 V). Fast-recovery, high-efficiency, or ultra-fast

recovery diodes are also suitable, but some types with an abrupt turnoff characteristic can cause instability and EMI problems. A fast-recovery diode with soft recovery characteristics is a better choice. Standard 60-Hz diodes (for example, 1N4001 or 1N5400, and so on) are also *not suitable*. See [表 8-3](#) for Schottky and *soft* fast-recovery diode selection guide.

### 8.1.6 Output Voltage Ripple and Transients

The output voltage of a switching power supply contains a sawtooth ripple voltage at the switcher frequency, typically about 1% of the output voltage, and can also contain short voltage spikes at the peaks of the sawtooth waveform.

The output ripple voltage is due mainly to the inductor sawtooth ripple current multiplied by the ESR of the output capacitor (see [セクション 8.1.2](#)).

The voltage spikes are present because of the fast switching action of the output switch, and the parasitic inductance of the output filter capacitor. To minimize these voltage spikes, special low inductance capacitors can be used, and their lead lengths must be kept short. Wiring inductance, stray capacitance, as well as the scope probe used to evaluate these transients, all contribute to the amplitude of these spikes.

An additional small LC filter (20  $\mu\text{H}$  and 100  $\mu\text{F}$ ) can be added to the output (as shown in [図 7-4](#)) to further reduce the amount of output ripple and transients. A 10  $\times$  reduction in output ripple voltage and transients is possible with this filter.

### 8.1.7 Feedback Connection

The LM2576 (fixed voltage versions) feedback pin must be wired to the output voltage point of the switching power supply. When using the adjustable version, physically locate both output voltage programming resistors near the LM2576 to avoid picking up unwanted noise. Avoid using resistors greater than 100 k $\Omega$  because of the increased chance of noise pickup.

### 8.1.8 $\overline{\text{ON}}$ /OFF INPUT

For normal operation, the  $\overline{\text{ON}}$  /OFF pin must be grounded or driven with a low-level TTL voltage (typically below 1.6 V). To put the regulator into standby mode, drive this pin with a high-level TTL or CMOS signal. The  $\overline{\text{ON}}$  /OFF pin can be safely pulled up to  $+V_{\text{IN}}$  without a resistor in series with it. The  $\overline{\text{ON}}$  /OFF pin must not be left open.

### 8.1.9 Inverting Regulator

[図 8-1](#) shows a LM2576-12 in a buck-boost configuration to generate a negative 12-V output from a positive input voltage. This circuit bootstraps the ground pin of the regulator to the negative output voltage, then by grounding the feedback pin, the regulator senses the inverted output voltage and regulates it to  $-12\text{ V}$ .

For an input voltage of 12 V or more, the maximum available output current in this configuration is approximately 700 mA. At lighter loads, the minimum input voltage required drops to approximately 4.7 V.

The switch currents in this buck-boost configuration are higher than in the standard buck-mode design, thus lowering the available output current. Also, the start-up input current of the buck-boost converter is higher than the standard buck-mode regulator, and this can overload an input power source with a current limit less than 5 A. Using a delayed turn-on or an undervoltage lockout circuit (described in [セクション 8.1.10](#)) can allow the input voltage to rise to a high enough level before the switcher can be allowed to turn on.

Because of the structural differences between the buck and the buck-boost regulator topologies, the buck regulator design procedure section can not be used to select the inductor or the output capacitor. The recommended range of inductor values for the buck-boost design is between 68  $\mu\text{H}$  and 220  $\mu\text{H}$ , and the output capacitor values must be larger than what is normally required for buck designs. Low input voltages or high output currents require a large value output capacitor (in the thousands of micro Farads).

The peak inductor current, which is the same as the peak switch current, can be calculated in [式 6](#):

$$I_p \approx \left( \frac{I_{LOAD}(V_{IN} + |V_{OUT}|)}{V_{IN}} + \frac{V_{IN}|V_{OUT}|}{V_{IN} + |V_{OUT}|} \right) \left( \frac{1}{2L_1 f_{OSC}} \right) \quad (6)$$

where  $f_{osc} = 52 \text{ kHz}$

Under normal continuous inductor current operating conditions, the minimum  $V_{IN}$  represents the worst case. Select an inductor that is rated for the peak current anticipated.

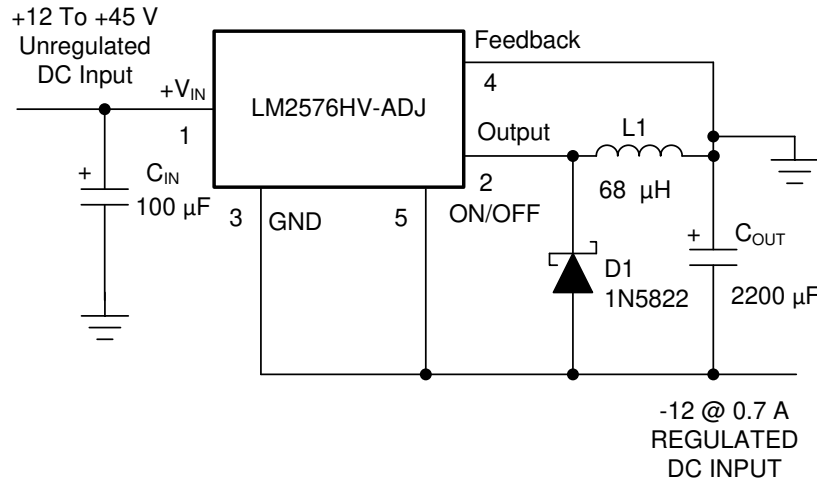

**8-1. Inverting Buck-Boost Develops -12 V**

Also, the maximum voltage appearing across the regulator is the absolute sum of the input and output voltage. For a -12-V output, the maximum input voltage for the LM2576 is +28 V, or +48 V for the LM2576HV.

### 8.1.10 Negative Boost Regulator

Another variation on the buck-boost topology is the negative boost configuration. The circuit in 8-2 accepts an input voltage ranging from -5 V to -12 V and provides a regulated -12-V output. Input voltages greater than -12 V causes the output to rise above -12 V, but does not damage the regulator.

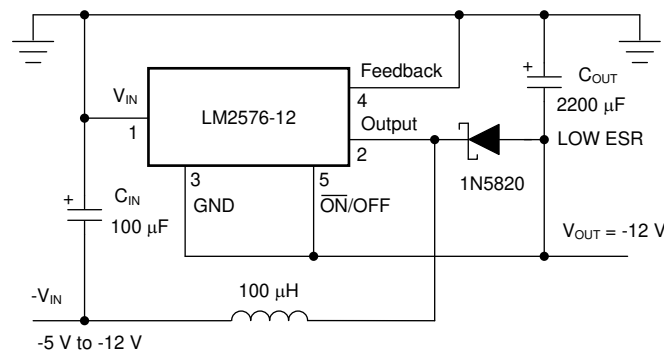

Typical Load Current 400 mA for  $V_{IN} = -5.2 \text{ V}$  750 mA for  $V_{IN} = -7 \text{ V}$  Heat sink can be required.

**8-2. Negative Boost**

Because of the boosting function of this type of regulator, the switch current is relatively high, especially at low input voltages. Output load current limitations are a result of the maximum current rating of the switch. Also, boost regulators can not provide current-limiting load protection in the event of a shorted load, so some other means (such as a fuse) can be necessary.

## 8.2 Typical Applications

### 8.2.1 Fixed Output Voltage Version

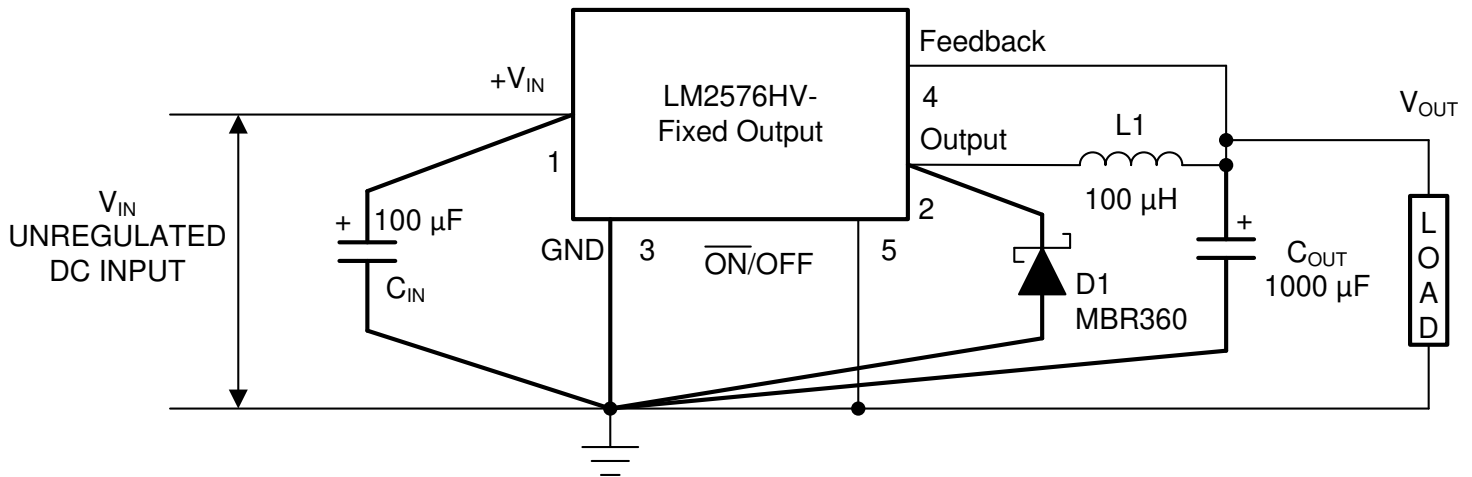

$C_{IN}$  — 100- $\mu$ F, 75-V, Aluminum Electrolytic  $C_{OUT}$  — 1000- $\mu$ F, 25-V, Aluminum Electrolytic  $D_1$  — Schottky, MBR360  $L_1$  — 100  $\mu$ H, Pulse Eng. PE-92108  $R_1$  — 2 k, 0.1%  $R_2$  — 6.12 k, 0.1%

图 8-3. Fixed Output Voltage Versions

#### 8.2.1.1 Design Requirements

表 8-1 lists the design parameters of this example.

表 8-1. Design Parameters

DESIGN PARAMETER	EXAMPLE VALUE
Regulated Output Voltage (3.3 V, 5 V, 12 V, or 15 V), $V_{OUT}$	5 V
Maximum Input Voltage, $V_{IN}(\text{Max})$	15 V
Maximum Load Current, $I_{LOAD}(\text{Max})$	3 A

#### 8.2.1.2 Detailed Design Procedure

##### 8.2.1.2.1 Custom Design with WEBENCH® Tools

[Click here](#) to create a custom design using the WEBENCH Power Designer.

1. Start by entering your  $V_{IN}$ ,  $V_{OUT}$  and  $I_{OUT}$  requirements.
2. Optimize your design for key parameters like efficiency, footprint and cost using the optimizer dial and compare this design with other possible solutions from Texas Instruments.
3. WEBENCH Power Designer provides you with a customized schematic along with a list of materials with real time pricing and component availability.
4. In most cases, you will also be able to:
  - Run electrical simulations to see important waveforms and circuit performance,
  - Run thermal simulations to understand the thermal performance of your board,
  - Export your customized schematic and layout into popular CAD formats,
  - Print PDF reports for the design, and share your design with colleagues.

##### 8.2.1.2.2 Inductor Selection (L1)

1. Select the correct Inductor value selection guide from 图 8-4, 图 8-5, 图 8-6, or 图 8-7. (Output voltages of 3.3 V, 5 V, 12 V or 15 V respectively). For other output voltages, see the design procedure for the adjustable version. Use the selection guide shown in 图 8-5.

- From the inductor value selection guide, identify the inductance region intersected by  $V_{IN}(\text{Max})$  and  $I_{LOAD}(\text{Max})$ , and note the inductor code for that region. From the selection guide, the inductance area intersected by the 15-V line and 3-A line is L100.
- Identify the inductor value from the inductor code, and select an appropriate inductor from the table shown in [Figure 8-4](#). Part numbers are listed for three inductor manufacturers. The inductor chosen must be rated for operation at the LM2576 switching frequency (52 kHz) and for a current rating of  $1.15 \times I_{LOAD}$ . For additional inductor information, see [Section 8.1.2](#). Inductor value required is 100  $\mu\text{H}$  from the table in [Figure 8-4](#). Choose AIE 415-0930, Pulse Engineering PE92108, or Renco RL2444.

#### 8.2.1.2.3 Output Capacitor Selection ( $C_{OUT}$ )

- The value of the output capacitor together with the inductor defines the dominant pole-pair of the switching regulator loop. For stable operation and an acceptable output ripple voltage, (approximately 1% of the output voltage) TI recommends a value between 100  $\mu\text{F}$  and 470  $\mu\text{F}$ . We choose  $C_{OUT} = 680\text{-}\mu\text{F}$  to 2000- $\mu\text{F}$  standard aluminum electrolytic.
- The voltage rating of the capacitor must be at least 1.5 times greater than the output voltage. For a 5-V regulator, a rating of at least 8 V is appropriate, and TI recommends a 10-V or 15-V rating. Capacitor voltage rating = 20 V. Higher voltage electrolytic capacitors generally have lower ESR numbers, and for this reason it can be necessary to select a capacitor rated for a higher voltage than can normally be needed.

#### 8.2.1.2.4 Catch Diode Selection ( $D1$ )

- The catch-diode current rating must be at least 1.2 times greater than the maximum load current. Also, if the power supply design must withstand a continuous output short, the diode must have a current rating equal to the maximum current limit of the LM2576. The most stressful condition for this diode is an overload or shorted output condition. For this example, a 3-A current rating is adequate.
- The reverse voltage rating of the diode must be at least 1.25 times the maximum input voltage. Use a 20-V 1N5823 or SR302 Schottky diode, or any of the suggested fast-recovery diodes shown in [Table 8-3](#).

#### 8.2.1.2.5 Input Capacitor ( $C_{IN}$ )

An aluminum or tantalum electrolytic bypass capacitor located close to the regulator is needed for stable operation. A 100- $\mu\text{F}$ , 25-V aluminum electrolytic capacitor located near the input and ground pins provides sufficient bypassing.

### 8.2.1.3 Application Curves



图 8-4. LM2576(HV)-3.3



图 8-5. LM2576(HV)-5.0

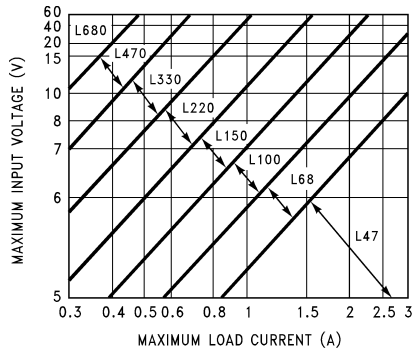

图 8-6. LM2576(HV)-12

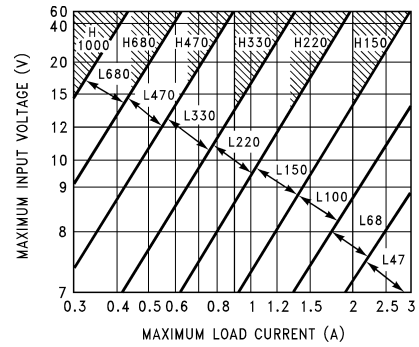

图 8-7. LM2576(HV)-15

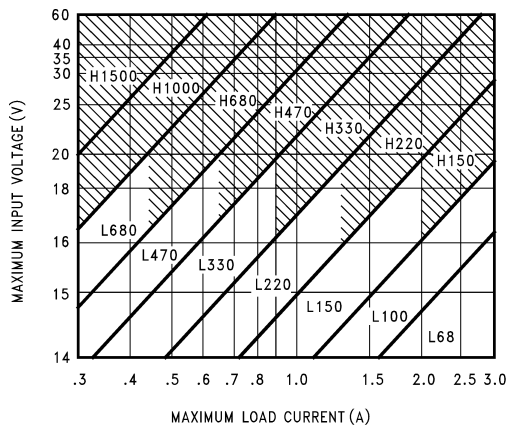

图 8-8. LM2576(HV)-ADJ

## 8.2.2 Adjusted Output Voltage Version

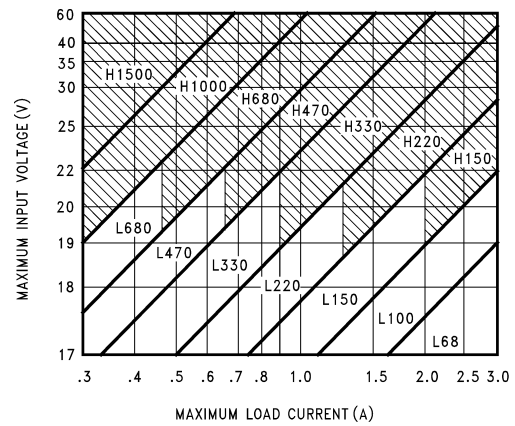

$$V_{OUT} = V_{REF} \left( 1 + \frac{R_2}{R_1} \right)$$

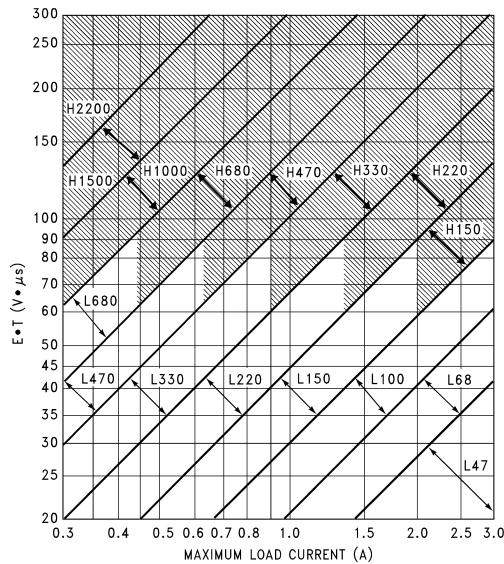
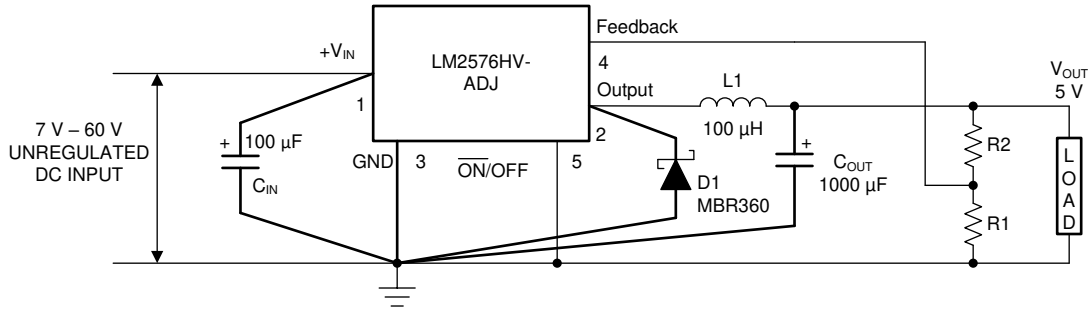
$$R_2 = R_1 \left( \frac{V_{OUT}}{V_{REF}} - 1 \right) \text{ where } V_{REF} = 1.23 \text{ V, } R_1 \text{ between } 1 \text{ k and } 5 \text{ k}$$

图 8-9. Adjustable Output Voltage Version

### 8.2.2.1 Design Requirements

表 8-2 lists the design parameters of this example.

表 8-2. Design Parameters

DESIGN PARAMETER	EXAMPLE VALUE
Regulated Output Voltage, $V_{OUT}$	10 V
Maximum Input Voltage, $V_{IN}(\text{Max})$	25 V
Maximum Load Current, $I_{LOAD}(\text{Max})$	3 A
Switching Frequency, F	Fixed at 52 kHz

### 8.2.2.2 Detailed Design Procedure

#### 8.2.2.2.1 Programming Output Voltage

Select  $R_1$  and  $R_2$ , as shown in 图 8-9.

Use 式 7 to select the appropriate resistor values.

$$V_{OUT} = V_{REF} \left( 1 + \frac{R_2}{R_1} \right) \text{ where } V_{REF} = 1.23 \text{ V} \quad (7)$$

$R_1$  can be between 1k and 5k. (For best temperature coefficient and stability with time, use 1% metal film resistors)

$$R_2 = R_1 \left( \frac{V_{OUT}}{V_{REF}} - 1 \right) = 1 \text{ k}\Omega \left( \frac{10 \text{ V}}{1.23 \text{ V}} - 1 \right) \text{ Select } R_1 = 1 \text{ K}\Omega \quad (8)$$

$R_2 = 1 \text{ k} (8.13 - 1) = 7.13 \text{ k}$ , closest 1% value is 7.15 k

#### 8.2.2.2.2 Inductor Selection (L1)

1. Calculate the inductor Volt • microsecond constant,  $E \cdot T$  ( $V \cdot \mu s$ ), from 式 9:

$$E \times T = (V_{IN} - V_{OUT}) \frac{V_{OUT}}{V_{IN}} \times \frac{1000}{F(\text{in kHz})} (V \times \mu s) \quad (9)$$

Calculate  $E \cdot T$  ( $V \cdot \mu s$ )

$$E \times T = (25 - 10) \times \frac{10}{25} \times \frac{1000}{52} = 115 \text{ V} \times \mu\text{s} \quad (10)$$

- Use the  $E \cdot T$  value from the previous formula and match it with the  $E \cdot T$  number on the vertical axis of the Inductor value selection guide shown in [Figure 8-8](#).

$$E \cdot T = 115 \text{ V} \cdot \mu\text{s}$$

- On the horizontal axis, select the maximum load current.

$$I_{\text{LOAD(Max)}} = 3 \text{ A}$$

- Identify the inductance region intersected by the  $E \cdot T$  value and the maximum load current value, and note the inductor code for that region.

$$\text{Inductance Region} = \text{H150}$$

- Identify the inductor value from the inductor code, and select an appropriate inductor from the table shown in [Table 8-4](#). Part numbers are listed for three inductor manufacturers. The inductor chosen must be rated for operation at the LM2576 switching frequency (52 kHz) and for a current rating of  $1.15 \times I_{\text{LOAD}}$ . For additional inductor information, see [Section 8.1.2](#).

$$\text{Inductor Value} = 150 \mu\text{H}$$

Choose from *AIE part #415-0936*, *Pulse Engineering part #PE-531115*, or *Renco part #RL2445*.

#### 8.2.2.2.3 Output Capacitor Selection ( $C_{\text{OUT}}$ )

- The value of the output capacitor together with the inductor defines the dominant pole-pair of the switching regulator loop. For stable operation, the capacitor must satisfy [Equation 8-1](#):

$$C_{\text{OUT}} \geq 13,300 \frac{V_{\text{IN(Max)}}}{V_{\text{OUT}} \times L (\mu\text{H})} (\mu\text{F})$$

[Equation 8-1](#) yields capacitor values between 10  $\mu\text{F}$  and 2200  $\mu\text{F}$  that satisfies the loop requirements for stable operation. But to achieve an acceptable output ripple voltage, (approximately 1% of the output voltage) and transient response, the output capacitor can need to be several times larger than [Equation 8-1](#) yields.

$$C_{\text{OUT}} \geq 13,300 \frac{25}{10 \times 150} = 22.2 \mu\text{F}$$

However, for acceptable output ripple voltage select

$$C_{\text{OUT}} \geq 680 \mu\text{F}$$

$$C_{\text{OUT}} = 680\text{-}\mu\text{F} \text{ electrolytic capacitor}$$

- The capacitor voltage rating must be at least 1.5 times greater than the output voltage. For a 10-V regulator, TI recommends a rating of at least 15 V or more. Higher voltage electrolytic capacitors generally have lower ESR numbers, and for this reason it can be necessary to select a capacitor rated for a higher voltage than can normally be needed.

#### 8.2.2.2.4 Catch Diode Selection (D1)

- The catch-diode current rating must be at least 1.2 times greater than the maximum load current. Also, if the power supply design must withstand a continuous output short, the diode must have a current rating equal to the maximum current limit of the LM2576. The most stressful condition for this diode is an overload or shorted output. See [Table 8-3](#). For this example, a 3.3-A current rating is adequate.
- The reverse voltage rating of the diode must be at least 1.25 times the maximum input voltage. Use a 30-V 31DQ03 Schottky diode, or any of the suggested fast-recovery diodes in [Table 8-3](#).



### 8.2.2.2.5 Input Capacitor (C<sub>IN</sub>)

An aluminum or tantalum electrolytic bypass capacitor located close to the regulator is needed for stable operation. A 100- $\mu$ F aluminum electrolytic capacitor located near the input and ground pins provides sufficient bypassing.

**表 8-3. Diode Selection Guide**

V <sub>R</sub>	SCHOTTKY		FAST RECOVERY	
	3 A	4 A to 6 A	3 A	4 A to 6 A
20 V	1N5820 MBR320P SR302	1N5823	The following diodes are all rated to 100-V 31DF1 HER302	The following diodes are all rated to 100-V 50WF10 MUR410 HER602
30 V	1N5821 MBR330 31DQ03 SR303	50WQ03 1N5824		
40 V	1N5822 MBR340 31DQ04 SR304	MBR340 50WQ04 1N5825		
50 V	MBR350 31DQ05 SR305	50WQ05		
60 V	MBR360 DQ06 SR306	50WR06 50SQ060		

**表 8-4. Inductor Selection by Manufacturer's Part Number**

INDUCTOR CODE	INDUCTOR VALUE	SCHOTT <sup>(1)</sup>	PULSE ENG. <sup>(2)</sup>	RENCO <sup>(3)</sup>
L47	47 $\mu$ H	671 26980	PE-53112	RL2442
L68	68 $\mu$ H	671 26990	PE-92114	RL2443
L100	100 $\mu$ H	671 27000	PE-92108	RL2444
L150	150 $\mu$ H	671 27010	PE-53113	RL1954
L220	220 $\mu$ H	671 27020	PE-52626	RL1953
L330	330 $\mu$ H	671 27030	PE-52627	RL1952
L470	470 $\mu$ H	671 27040	PE-53114	RL1951
L680	680 $\mu$ H	671 27050	PE-52629	RL1950
H150	150 $\mu$ H	671 27060	PE-53115	RL2445
H220	220 $\mu$ H	671 27070	PE-53116	RL2446
H330	330 $\mu$ H	671 27080	PE-53117	RL2447
H470	470 $\mu$ H	671 27090	PE-53118	RL1961
H680	680 $\mu$ H	671 27100	PE-53119	RL1960
H1000	1000 $\mu$ H	671 27110	PE-53120	RL1959
H1500	1500 $\mu$ H	671 27120	PE-53121	RL1958
H2200	2200 $\mu$ H	671 27130	PE-53122	RL2448

- (1) Schott Corporation, (612) 475-1173, 1000 Parkers Lake Road, Wayzata, MN 55391.
- (2) Pulse Engineering, (619) 674-8100, P.O. Box 12235, San Diego, CA 92112.
- (3) Renco Electronics Incorporated, (516) 586-5566, 60 Jeffryn Blvd. East, Deer Park, NY 11729.

### 8.3 Power Supply Recommendations

As in any switching regulator, layout is very important. Rapidly switching currents associated with wiring inductance generate voltage transients which can cause problems. For minimal inductance and ground loops, the length of the leads indicated by heavy lines must be kept as short as possible. Single-point grounding (as indicated) or ground plane construction must be used for best results. When using the adjustable version, physically locate the programming resistors near the regulator, to keep the sensitive feedback wiring short.

### 8.4 Layout

#### 8.4.1 Layout Guidelines

Board layout is critical for the proper operation of switching power supplies. First, the ground plane area must be sufficient for thermal dissipation purposes. Second, appropriate guidelines must be followed to reduce the effects of switching noise. Switch mode converters are very fast switching devices. In such cases, the rapid increase of input current combined with the parasitic trace inductance generates unwanted  $L di/dt$  noise spikes. The magnitude of this noise tends to increase as the output current increases. This noise can turn into electromagnetic interference (EMI) and can also cause problems in device performance. Therefore, take care in layout to minimize the effect of this switching noise. The most important layout rule is to keep the AC current loops as small as possible. [Figure 8-10](#) shows the current flow in a buck converter. The top schematic shows a dotted line which represents the current flow during the top-switch ON-state. The middle schematic shows the current flow during the top-switch OFF-state. The bottom schematic shows the currents referred to as AC currents. These AC currents are the most critical because they are changing in a very short time period. The dotted lines of the bottom schematic are the traces to keep as short and wide as possible. This also yields a small loop area reducing the loop inductance. To avoid functional problems due to layout, review the PCB layout example. Best results are achieved if the placement of the LM2576 device, the bypass capacitor, the Schottky diode, RFBB, RFBT, and the inductor are placed as shown in [Figure 8-11](#). TI also recommends using 2-oz copper boards or heavier to help thermal dissipation and to reduce the parasitic inductances of board traces. See [AN-1229 SIMPLE SWITCHER® PCB Layout Guidelines](#) application report for more information.

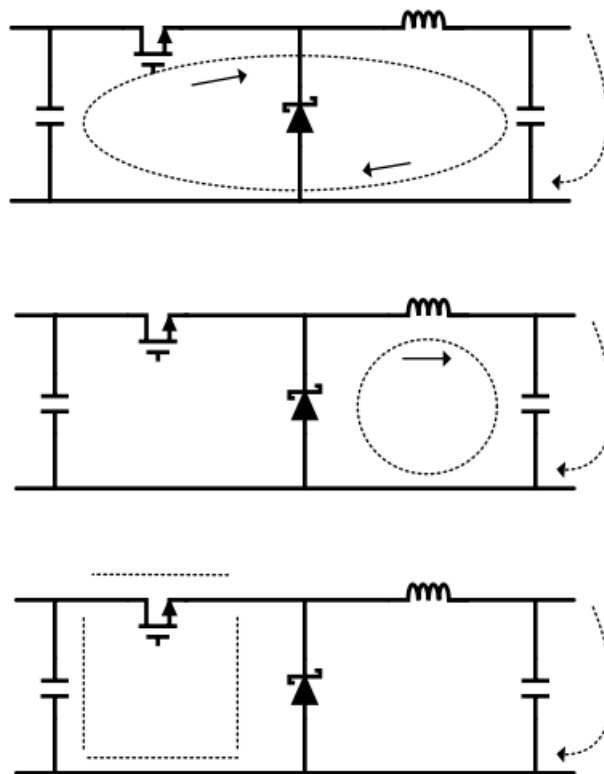

**Figure 8-10. Current Flow in Buck Application**

## 8.4.2 Layout Example



图 8-11. LM2576xx Layout Example

## 8.4.3 Grounding

To maintain output voltage stability, the power ground connections must be low-impedance (see 图 8-3 and 图 8-9). For the 5-lead TO-220 and DDPACK/TO-263 style package, both the tab and pin 3 are ground and either connection can be used, as they are both part of the same copper lead frame.

## 8.4.4 Heat Sink and Thermal Considerations

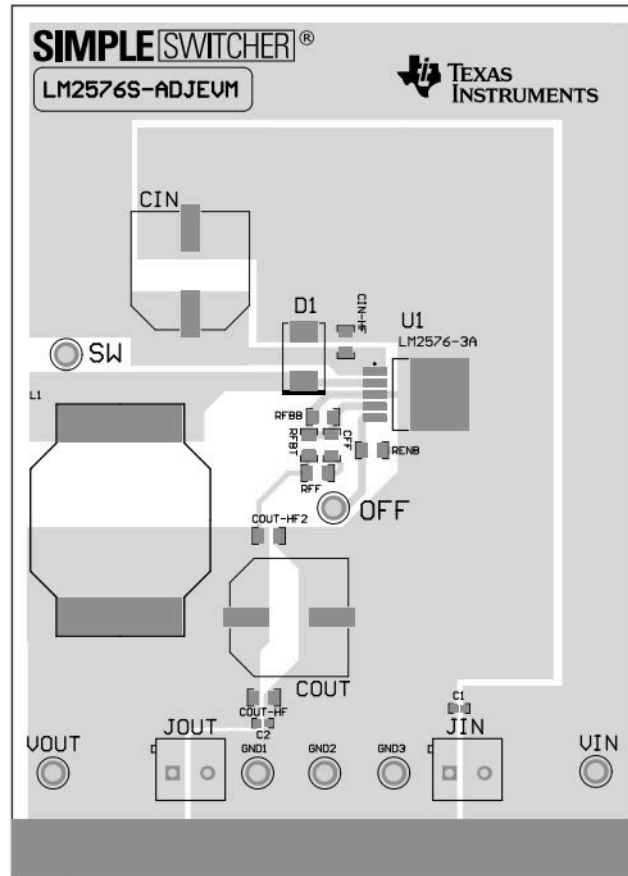
In many cases, only a small heat sink is required to keep the LM2576 junction temperature within the allowed operating range. For each application, to determine whether or not a heat sink is required, the following must be identified:

1. Maximum ambient temperature (in the application).
2. Maximum regulator power dissipation (in application).
3. Maximum allowed junction temperature (125°C for the LM2576). For a safe, conservative design, a temperature approximately 15°C cooler than the maximum temperatures must be selected.
4. LM2576 package thermal resistances  $\theta_{JA}$  and  $\theta_{JC}$ .

Total power dissipated by the LM2576 can be estimated in 式 11:

$$P_D = (V_{IN})(I_Q) + (V_O/V_{IN})(I_{LOAD})(V_{SAT}) \quad (11)$$

where

- $I_Q$  (quiescent current) and  $V_{SAT}$  can be found in セクション 6.11 shown previously,

- $V_{IN}$  is the applied minimum input voltage,  $V_O$  is the regulated output voltage,
- and  $I_{LOAD}$  is the load current.

The dynamic losses during turnon and turnoff are negligible if a Schottky type catch diode is used.

When no heat sink is used, the junction temperature rise can be determined by 式 12:

$$\Delta T_J = (P_D) (\theta_{JA}) \quad (12)$$

To arrive at the actual operating junction temperature, add the junction temperature rise to the maximum ambient temperature.

$$T_J = \Delta T_J + T_A \quad (13)$$

If the actual operating junction temperature is greater than the selected safe operating junction temperature determined in step 3, then a heat sink is required.

When using a heat sink, the junction temperature rise can be determined by 式 13:

$$\Delta T_J = (P_D) (\theta_{JC} + \theta_{interface} + \theta_{Heat\ sink}) \quad (14)$$

The operating junction temperature is:

$$T_J = T_A + \Delta T_J \quad (15)$$

As in 式 15, if the actual operating junction temperature is greater than the selected safe operating junction temperature, then a larger heat sink is required (one that has a lower thermal resistance).

## 9 Device and Documentation Support

### 9.1 Device Support

#### 9.1.1 Device Nomenclature

##### 9.1.1.1 Definition of Terms

<b>BUCK REGULATOR</b>	A switching regulator topology in which a higher voltage is converted to a lower voltage. Also known as a step-down switching regulator.
<b>BUCK-BOOST REGULATOR</b>	A switching regulator topology in which a positive voltage is converted to a negative voltage without a transformer.
<b>DUTY CYCLE (D)</b>	Ratio of the output switch on-time to the oscillator period. For buck regulator: $D = \frac{t_{ON}}{T} = \frac{V_{OUT}}{V_{IN}} \quad (16)$ <p>For buck-boost regulator:</p> $D = \frac{t_{ON}}{T} = \frac{ V_{OUT} }{ V_{OUT}  + V_{IN}} \quad (17)$
<b>CATCH DIODE OR CURRENT STEERING DIODE</b>	The diode which provides a return path for the load current when the LM2576 switch is OFF.
<b>EFFICIENCY (<math>\eta</math>)</b>	The proportion of input power actually delivered to the load. $\eta = \frac{P_{OUT}}{P_{IN}} = \frac{P_{OUT}}{P_{OUT} + P_{LOSS}} \quad (18)$
<b>CAPACITOR EQUIVALENT SERIES RESISTANCE (ESR)</b>	The purely resistive component of a real capacitor impedance (see <a href="#">Figure 9-1</a> ). It causes power loss resulting in capacitor heating, which directly affects the capacitor operating lifetime. When used as a switching regulator output filter, higher ESR values result in higher output ripple voltages.
	
<b>Figure 9-1. Simple Model of a Real Capacitor</b>	
	Most standard aluminum electrolytic capacitors in the 100 $\mu$ F–1000 $\mu$ F range have 0.5 $\Omega$ to 0.1 $\Omega$ ESR. Higher-grade capacitors (low-ESR, high-frequency, or low-inductance) in the 100 $\mu$ F to 1000 $\mu$ F range generally have ESR of less than 0.15 $\Omega$ .
<b>EQUIVALENT SERIES INDUCTANCE (ESL)</b>	The pure inductance component of a capacitor (see <a href="#">Figure 9-1</a> ). The amount of inductance is determined to a large extent on the capacitor construction. In a buck regulator, this unwanted inductance causes voltage spikes to appear on the output.
<b>OUTPUT RIPPLE VOLTAGE</b>	The AC component of the switching regulator output voltage. It is usually dominated by the output capacitor ESR multiplied by the inductor ripple current ( $\Delta I_{IND}$ ). The peak-to-peak value of this sawtooth ripple current can be determined by reading <a href="#">Section 8.1.3</a> .
<b>CAPACITOR RIPPLE CURRENT</b>	RMS value of the maximum allowable alternating current at which a capacitor can be operated continuously at a specified temperature.
<b>STANDBY QUIESCENT CURRENT (<math>I_{STBY}</math>)</b>	Supply current required by the LM2576 when in the standby mode ( $\overline{ON}$ /OFF pin is driven to TTL-high voltage, thus turning the output switch OFF).

<b>INDUCTOR RIPPLE CURRENT (<math>\Delta I_{IND}</math>)</b>	The peak-to-peak value of the inductor current waveform, typically a sawtooth waveform when the regulator is operating in the continuous mode (vs. discontinuous mode).
<b>CONTINUOUS/ DISCONTINUOUS MODE OPERATION</b>	Relates to the inductor current. In the continuous mode, the inductor current is always flowing and never drops to zero, vs. the discontinuous mode, where the inductor current drops to zero for a period of time in the normal switching cycle.
<b>INDUCTOR SATURATION</b>	The condition which exists when an inductor cannot hold any more magnetic flux. When an inductor saturates, the inductor appears less inductive and the resistive component dominates. Inductor current is then limited only by the DC resistance of the wire and the available source current.
<b>OPERATING VOLT MICROSECOND CONSTANT (<math>E \cdot T_{op}</math>)</b>	The product (in Volt $\cdot\mu$ s) of the voltage applied to the inductor and the time the voltage is applied. This $E \cdot T_{op}$ constant is a measure of the energy handling capability of an inductor and is dependent upon the type of core, the core area, the number of turns, and the duty cycle.

## 9.1.2 Development Support

### 9.1.2.1 Custom Design with WEBENCH® Tools

[Click here](#) to create a custom design using the WEBENCH Power Designer.

1. Start by entering your  $V_{IN}$ ,  $V_{OUT}$  and  $I_{OUT}$  requirements.
2. Optimize your design for key parameters like efficiency, footprint and cost using the optimizer dial and compare this design with other possible solutions from Texas Instruments.
3. WEBENCH Power Designer provides you with a customized schematic along with a list of materials with real time pricing and component availability.
4. In most cases, you will also be able to:
  - Run electrical simulations to see important waveforms and circuit performance,
  - Run thermal simulations to understand the thermal performance of your board,
  - Export your customized schematic and layout into popular CAD formats,
  - Print PDF reports for the design, and share your design with colleagues.

## 9.2 Documentation Support

### 9.2.1 Related Documentation

For related documentation, see the following:

[AN-1229 SIMPLE SWITCHER® PCB Layout Guidelines application report](#)

## 9.3 サポート・リソース

TI E2E™ サポート・フォーラムは、エンジニアが検証済みの回答と設計に関するヒントをエキスパートから迅速かつ直接得ることができる場所です。既存の回答を検索したり、独自の質問をしたりすることで、設計に必要な支援を迅速に得ることができます。

リンクされているコンテンツは、該当する貢献者により、現状のまま提供されるものです。これらは TI の仕様を構成するものではなく、必ずしも TI の見解を反映したものではありません。TI の[使用条件](#)を参照してください。

## 9.4 ドキュメントの更新通知を受け取る方法

ドキュメントの更新についての通知を受け取るには、[ti.com](#) のデバイス製品フォルダを開いてください。「更新の通知を受け取る」をクリックして登録すると、変更されたすべての製品情報に関するダイジェストを毎週受け取れます。変更の詳細については、修正されたドキュメントに含まれている改訂履歴をご覧ください。

## 9.5 Trademarks

TI E2E™ is a trademark of Texas Instruments.

SIMPLE SWITCHER® and WEBENCH® are registered trademarks of Texas Instruments.

すべての商標は、それぞれの所有者に帰属します。

## 9.6 静電気放電に関する注意事項



この IC は、ESD によって破損する可能性があります。テキサス・インスツルメンツは、IC を取り扱う際には常に適切な注意を払うことを推奨します。正しい取り扱いおよび設置手順に従わない場合、デバイスを破損するおそれがあります。

ESD による破損は、わずかな性能低下からデバイスの完全な故障まで多岐にわたります。精密な IC の場合、パラメータがわずかに変化するだけで公表されている仕様から外れる可能性があるため、破損が発生しやすくなっています。

## 9.7 用語集

[テキサス・インスツルメンツ用語集](#) この用語集には、用語や略語の一覧および定義が記載されています。

## 10 Mechanical, Packaging, and Orderable Information

The following pages include mechanical, packaging, and orderable information. This information is the most current data available for the designated devices. This data is subject to change without notice and revision of this document. For browser-based versions of this data sheet, refer to the left-hand navigation.

**PACKAGING INFORMATION**

Orderable Device	Status (1)	Package Type	Package Drawing	Pins	Package Qty	Eco Plan (2)	Lead finish/ Ball material (6)	MSL Peak Temp (3)	Op Temp (°C)	Device Marking (4/5)	Samples
LM2576HVS-12	LIFEBUY	DDPAK/ TO-263	KTT	5	45	Non-RoHS & Green	Call TI	Level-3-235C-168 HR	-40 to 125	LM2576 HVS-12 P+	
LM2576HVS-12/NOPB	ACTIVE	DDPAK/ TO-263	KTT	5	45	RoHS-Exempt & Green	SN	Level-3-245C-168 HR	-40 to 125	LM2576 HVS-12 P+	Samples
LM2576HVS-3.3/NOPB	ACTIVE	DDPAK/ TO-263	KTT	5	45	RoHS-Exempt & Green	SN	Level-3-245C-168 HR	-40 to 125	LM2576 HVS-3.3 P+	Samples
LM2576HVS-5.0	LIFEBUY	DDPAK/ TO-263	KTT	5	45	Non-RoHS & Green	Call TI	Level-3-235C-168 HR	-40 to 125	LM2576 HVS-5.0 P+	
LM2576HVS-5.0/NOPB	ACTIVE	DDPAK/ TO-263	KTT	5	45	RoHS-Exempt & Green	SN	Level-3-245C-168 HR	-40 to 125	LM2576 HVS-5.0 P+	Samples
LM2576HVS-ADJ	LIFEBUY	DDPAK/ TO-263	KTT	5	45	Non-RoHS & Green	Call TI	Level-3-235C-168 HR	-40 to 125	LM2576 HVS-ADJ P+	
LM2576HVS-ADJ/NOPB	ACTIVE	DDPAK/ TO-263	KTT	5	45	RoHS-Exempt & Green	SN	Level-3-245C-168 HR	-40 to 125	LM2576 HVS-ADJ P+	Samples
LM2576HVSX-12	LIFEBUY	DDPAK/ TO-263	KTT	5	500	Non-RoHS & Green	Call TI	Level-3-235C-168 HR	-40 to 125	LM2576 HVS-12 P+	
LM2576HVSX-12/NOPB	ACTIVE	DDPAK/ TO-263	KTT	5	500	RoHS-Exempt & Green	SN	Level-3-245C-168 HR	-40 to 125	LM2576 HVS-12 P+	Samples
LM2576HVSX-3.3/NOPB	ACTIVE	DDPAK/ TO-263	KTT	5	500	RoHS-Exempt & Green	SN	Level-3-245C-168 HR	-40 to 125	LM2576 HVS-3.3 P+	Samples
LM2576HVSX-5.0	LIFEBUY	DDPAK/ TO-263	KTT	5	500	Non-RoHS & Green	Call TI	Level-3-235C-168 HR	-40 to 125	LM2576 HVS-5.0 P+	
LM2576HVSX-5.0/NOPB	ACTIVE	DDPAK/ TO-263	KTT	5	500	RoHS-Exempt & Green	SN	Level-3-245C-168 HR	-40 to 125	LM2576 HVS-5.0 P+	Samples
LM2576HVSX-ADJ	LIFEBUY	DDPAK/ TO-263	KTT	5	500	Non-RoHS & Green	Call TI	Level-3-235C-168 HR	-40 to 125	LM2576 HVS-ADJ P+	
LM2576HVSX-ADJ/NOPB	ACTIVE	DDPAK/ TO-263	KTT	5	500	RoHS-Exempt & Green	SN	Level-3-245C-168 HR	-40 to 125	LM2576 HVS-ADJ P+	Samples
LM2576HVT-12	LIFEBUY	TO-220	KC	5	45	Non-RoHS & Green	Call TI	Level-1-NA-UNLIM	-40 to 125	LM2576HVT -12 P+	
LM2576HVT-12/LF03	ACTIVE	TO-220	NDH	5	45	RoHS & Green	SN	Level-1-NA-UNLIM		LM2576HVT -12 P+	Samples
LM2576HVT-12/NOPB	ACTIVE	TO-220	KC	5	45	RoHS & Green	SN	Level-1-NA-UNLIM	-40 to 125	LM2576HVT	Samples



Orderable Device	Status (1)	Package Type	Package Drawing	Pins	Package Qty	Eco Plan (2)	Lead finish/ Ball material (6)	MSL Peak Temp (3)	Op Temp (°C)	Device Marking (4/5)	Samples
										-12 P+	
LM2576HVT-15/LB03	LIFEBUY	TO-220	NDH	5	45	Non-RoHS & Green	Call TI	Level-1-NA-UNLIM		LM2576HVT -15 P+	
LM2576HVT-15/LF03	ACTIVE	TO-220	NDH	5	45	RoHS & Green	SN	Level-1-NA-UNLIM		LM2576HVT -15 P+	<a href="#">Samples</a>
LM2576HVT-15/NOPB	ACTIVE	TO-220	KC	5	45	RoHS & Green	SN	Level-1-NA-UNLIM	-40 to 125	LM2576HVT -15 P+	<a href="#">Samples</a>
LM2576HVT-5.0	LIFEBUY	TO-220	KC	5	45	Non-RoHS & Green	Call TI	Level-1-NA-UNLIM	-40 to 125	LM2576HVT -5.0 P+	
LM2576HVT-5.0/LB03	LIFEBUY	TO-220	NDH	5	45	Non-RoHS & Green	Call TI	Level-1-NA-UNLIM		LM2576HVT -5.0 P+	
LM2576HVT-5.0/LF02	ACTIVE	TO-220	NEB	5	45	RoHS & Green	SN	Level-1-NA-UNLIM		LM2576HVT -5.0 P+	<a href="#">Samples</a>
LM2576HVT-5.0/LF03	ACTIVE	TO-220	NDH	5	45	RoHS & Green	SN	Level-1-NA-UNLIM		LM2576HVT -5.0 P+	<a href="#">Samples</a>
LM2576HVT-5.0/NOPB	ACTIVE	TO-220	KC	5	45	RoHS & Green	SN	Level-1-NA-UNLIM	-40 to 125	LM2576HVT -5.0 P+	<a href="#">Samples</a>
LM2576HVT-ADJ	LIFEBUY	TO-220	KC	5	45	Non-RoHS & Green	Call TI	Level-1-NA-UNLIM	-40 to 125	LM2576HVT -ADJ P+	
LM2576HVT-ADJ/LB03	LIFEBUY	TO-220	NDH	5	45	Non-RoHS & Green	Call TI	Level-1-NA-UNLIM		LM2576HVT -ADJ P+	
LM2576HVT-ADJ/LF03	ACTIVE	TO-220	NDH	5	45	RoHS & Green	SN	Level-1-NA-UNLIM		LM2576HVT -ADJ P+	<a href="#">Samples</a>
LM2576HVT-ADJ/NOPB	ACTIVE	TO-220	KC	5	45	RoHS & Green	SN	Level-1-NA-UNLIM	-40 to 125	LM2576HVT -ADJ P+	<a href="#">Samples</a>
LM2576S-12	LIFEBUY	DDPAK/ TO-263	KTT	5	45	Non-RoHS & Green	Call TI	Level-3-235C-168 HR	-40 to 125	LM2576S -12 P+	
LM2576S-12/NOPB	ACTIVE	DDPAK/ TO-263	KTT	5	45	RoHS-Exempt & Green	SN	Level-3-245C-168 HR	-40 to 125	LM2576S -12 P+	<a href="#">Samples</a>
LM2576S-3.3/NOPB	ACTIVE	DDPAK/ TO-263	KTT	5	45	RoHS-Exempt & Green	SN	Level-3-245C-168 HR	-40 to 125	LM2576S -3.3 P+	<a href="#">Samples</a>
LM2576S-5.0	LIFEBUY	DDPAK/ TO-263	KTT	5	45	Non-RoHS & Green	Call TI	Level-3-235C-168 HR	-40 to 125	LM2576S -5.0 P+	
LM2576S-5.0/NOPB	ACTIVE	DDPAK/ TO-263	KTT	5	45	RoHS-Exempt & Green	SN	Level-3-245C-168 HR	-40 to 125	LM2576S -5.0 P+	<a href="#">Samples</a>

Orderable Device	Status (1)	Package Type	Package Drawing	Pins	Package Qty	Eco Plan (2)	Lead finish/ Ball material (6)	MSL Peak Temp (3)	Op Temp (°C)	Device Marking (4/5)	Samples
LM2576S-ADJ/NOPB	ACTIVE	DDPAK/ TO-263	KTT	5	45	RoHS-Exempt & Green	SN	Level-3-245C-168 HR	-40 to 125	LM2576S -ADJ P+	<a href="#">Samples</a>
LM2576SX-3.3/NOPB	ACTIVE	DDPAK/ TO-263	KTT	5	500	RoHS-Exempt & Green	SN	Level-3-245C-168 HR	-40 to 125	LM2576S -3.3 P+	<a href="#">Samples</a>
LM2576SX-5.0/NOPB	ACTIVE	DDPAK/ TO-263	KTT	5	500	RoHS-Exempt & Green	SN	Level-3-245C-168 HR	-40 to 125	LM2576S -5.0 P+	<a href="#">Samples</a>
LM2576SX-ADJ/NOPB	ACTIVE	DDPAK/ TO-263	KTT	5	500	RoHS-Exempt & Green	SN	Level-3-245C-168 HR	-40 to 125	LM2576S -ADJ P+	<a href="#">Samples</a>
LM2576T-12	LIFEBUY	TO-220	KC	5	45	Non-RoHS & Green	Call TI	Level-1-NA-UNLIM	-40 to 125	LM2576T -12 P+	
LM2576T-12/LB03	LIFEBUY	TO-220	NDH	5	45	Non-RoHS & Green	Call TI	Level-1-NA-UNLIM		LM2576T -12 P+	
LM2576T-12/LF03	ACTIVE	TO-220	NDH	5	45	RoHS & Green	SN	Level-1-NA-UNLIM		LM2576T -12 P+	<a href="#">Samples</a>
LM2576T-12/NOPB	ACTIVE	TO-220	KC	5	45	RoHS & Green	SN	Level-1-NA-UNLIM	-40 to 125	LM2576T -12 P+	<a href="#">Samples</a>
LM2576T-15/LF03	ACTIVE	TO-220	NDH	5	45	RoHS & Green	SN	Level-1-NA-UNLIM		LM2576T -15 P+	<a href="#">Samples</a>
LM2576T-15/NOPB	ACTIVE	TO-220	KC	5	45	RoHS & Green	SN	Level-1-NA-UNLIM	-40 to 125	LM2576T -15 P+	<a href="#">Samples</a>
LM2576T-3.3/LF03	ACTIVE	TO-220	NDH	5	45	RoHS & Green	SN	Level-1-NA-UNLIM		LM2576T -3.3 P+	<a href="#">Samples</a>
LM2576T-3.3/NOPB	ACTIVE	TO-220	KC	5	45	RoHS & Green	SN	Level-1-NA-UNLIM	-40 to 125	LM2576T -3.3 P+	<a href="#">Samples</a>
LM2576T-5.0	LIFEBUY	TO-220	KC	5	45	Non-RoHS & Green	Call TI	Level-1-NA-UNLIM	-40 to 125	LM2576T -5.0 P+	
LM2576T-5.0/LB03	LIFEBUY	TO-220	NDH	5	45	Non-RoHS & Green	Call TI	Level-1-NA-UNLIM		LM2576T -5.0 P+	
LM2576T-5.0/LF02	ACTIVE	TO-220	NEB	5	45	RoHS & Green	SN	Level-1-NA-UNLIM		LM2576T -5.0 P+	<a href="#">Samples</a>
LM2576T-5.0/LF03	ACTIVE	TO-220	NDH	5	45	RoHS & Green	SN	Level-1-NA-UNLIM		LM2576T -5.0 P+	<a href="#">Samples</a>
LM2576T-5.0/NOPB	ACTIVE	TO-220	KC	5	45	RoHS & Green	SN	Level-1-NA-UNLIM	-40 to 125	LM2576T -5.0 P+	<a href="#">Samples</a>

Orderable Device	Status (1)	Package Type	Package Drawing	Pins	Package Qty	Eco Plan (2)	Lead finish/ Ball material (6)	MSL Peak Temp (3)	Op Temp (°C)	Device Marking (4/5)	Samples
LM2576T-ADJ	LIFEBUY	TO-220	KC	5	45	Non-RoHS & Green	Call TI	Level-1-NA-UNLIM	-40 to 125	LM2576T -ADJ P+	
LM2576T-ADJ/LB03	LIFEBUY	TO-220	NDH	5	45	Non-RoHS & Green	Call TI	Level-1-NA-UNLIM		LM2576T -ADJ P+	
LM2576T-ADJ/LF02	ACTIVE	TO-220	NEB	5	45	RoHS & Green	SN	Level-1-NA-UNLIM		LM2576T -ADJ P+	Samples
LM2576T-ADJ/LF03	ACTIVE	TO-220	NDH	5	45	RoHS & Green	SN	Level-1-NA-UNLIM		LM2576T -ADJ P+	Samples
LM2576T-ADJ/NOPB	ACTIVE	TO-220	KC	5	45	RoHS & Green	SN	Level-1-NA-UNLIM	-40 to 125	LM2576T -ADJ P+	Samples

(1) The marketing status values are defined as follows:

**ACTIVE:** Product device recommended for new designs.

**LIFEBUY:** TI has announced that the device will be discontinued, and a lifetime-buy period is in effect.

**NRND:** Not recommended for new designs. Device is in production to support existing customers, but TI does not recommend using this part in a new design.

**PREVIEW:** Device has been announced but is not in production. Samples may or may not be available.

**OBSELETE:** TI has discontinued the production of the device.

(2) **RoHS:** TI defines "RoHS" to mean semiconductor products that are compliant with the current EU RoHS requirements for all 10 RoHS substances, including the requirement that RoHS substance do not exceed 0.1% by weight in homogeneous materials. Where designed to be soldered at high temperatures, "RoHS" products are suitable for use in specified lead-free processes. TI may reference these types of products as "Pb-Free".

**RoHS Exempt:** TI defines "RoHS Exempt" to mean products that contain lead but are compliant with EU RoHS pursuant to a specific EU RoHS exemption.

**Green:** TI defines "Green" to mean the content of Chlorine (Cl) and Bromine (Br) based flame retardants meet JS709B low halogen requirements of <=1000ppm threshold. Antimony trioxide based flame retardants must also meet the <=1000ppm threshold requirement.

(3) MSL, Peak Temp. - The Moisture Sensitivity Level rating according to the JEDEC industry standard classifications, and peak solder temperature.

(4) There may be additional marking, which relates to the logo, the lot trace code information, or the environmental category on the device.

(5) Multiple Device Markings will be inside parentheses. Only one Device Marking contained in parentheses and separated by a "~" will appear on a device. If a line is indented then it is a continuation of the previous line and the two combined represent the entire Device Marking for that device.

(6) Lead finish/Ball material - Orderable Devices may have multiple material finish options. Finish options are separated by a vertical ruled line. Lead finish/Ball material values may wrap to two lines if the finish value exceeds the maximum column width.

**Important Information and Disclaimer:** The information provided on this page represents TI's knowledge and belief as of the date that it is provided. TI bases its knowledge and belief on information provided by third parties, and makes no representation or warranty as to the accuracy of such information. Efforts are underway to better integrate information from third parties. TI has taken and continues to take reasonable steps to provide representative and accurate information but may not have conducted destructive testing or chemical analysis on incoming materials and chemicals. TI and TI suppliers consider certain information to be proprietary, and thus CAS numbers and other limited information may not be available for release.

In no event shall TI's liability arising out of such information exceed the total purchase price of the TI part(s) at issue in this document sold by TI to Customer on an annual basis.

**TAPE AND REEL INFORMATION**

**QUADRANT ASSIGNMENTS FOR PIN 1 ORIENTATION IN TAPE**

\*All dimensions are nominal

Device	Package Type	Package Drawing	Pins	SPQ	Reel Diameter (mm)	Reel Width W1 (mm)	A0 (mm)	B0 (mm)	K0 (mm)	P1 (mm)	W (mm)	Pin1 Quadrant
LM2576HVSX-12	DDPAK/ TO-263	KTT	5	500	330.0	24.4	10.75	14.85	5.0	16.0	24.0	Q2
LM2576HVSX-12/NOPB	DDPAK/ TO-263	KTT	5	500	330.0	24.4	10.75	14.85	5.0	16.0	24.0	Q2
LM2576HVSX-3.3/NOPB	DDPAK/ TO-263	KTT	5	500	330.0	24.4	10.75	14.85	5.0	16.0	24.0	Q2
LM2576HVSX-5.0	DDPAK/ TO-263	KTT	5	500	330.0	24.4	10.75	14.85	5.0	16.0	24.0	Q2
LM2576HVSX-5.0/NOPB	DDPAK/ TO-263	KTT	5	500	330.0	24.4	10.75	14.85	5.0	16.0	24.0	Q2
LM2576HVSX-ADJ	DDPAK/ TO-263	KTT	5	500	330.0	24.4	10.75	14.85	5.0	16.0	24.0	Q2
LM2576HVSX-ADJ/NOPB	DDPAK/ TO-263	KTT	5	500	330.0	24.4	10.75	14.85	5.0	16.0	24.0	Q2
LM2576SX-3.3/NOPB	DDPAK/ TO-263	KTT	5	500	330.0	24.4	10.75	14.85	5.0	16.0	24.0	Q2
LM2576SX-5.0/NOPB	DDPAK/ TO-263	KTT	5	500	330.0	24.4	10.75	14.85	5.0	16.0	24.0	Q2

Device	Package Type	Package Drawing	Pins	SPQ	Reel Diameter (mm)	Reel Width W1 (mm)	A0 (mm)	B0 (mm)	K0 (mm)	P1 (mm)	W (mm)	Pin1 Quadrant
LM2576SX-ADJ/NOPB	DDPAK/ TO-263	KTT	5	500	330.0	24.4	10.75	14.85	5.0	16.0	24.0	Q2

**TAPE AND REEL BOX DIMENSIONS**

\*All dimensions are nominal

Device	Package Type	Package Drawing	Pins	SPQ	Length (mm)	Width (mm)	Height (mm)
LM2576HVSX-12	DDPAK/TO-263	KTT	5	500	356.0	356.0	45.0
LM2576HVSX-12/NOPB	DDPAK/TO-263	KTT	5	500	356.0	356.0	45.0
LM2576HVSX-3.3/NOPB	DDPAK/TO-263	KTT	5	500	356.0	356.0	45.0
LM2576HVSX-5.0	DDPAK/TO-263	KTT	5	500	356.0	356.0	45.0
LM2576HVSX-5.0/NOPB	DDPAK/TO-263	KTT	5	500	356.0	356.0	45.0
LM2576HVSX-ADJ	DDPAK/TO-263	KTT	5	500	356.0	356.0	45.0
LM2576HVSX-ADJ/NOPB	DDPAK/TO-263	KTT	5	500	356.0	356.0	45.0
LM2576SX-3.3/NOPB	DDPAK/TO-263	KTT	5	500	356.0	356.0	45.0
LM2576SX-5.0/NOPB	DDPAK/TO-263	KTT	5	500	356.0	356.0	45.0
LM2576SX-ADJ/NOPB	DDPAK/TO-263	KTT	5	500	356.0	356.0	45.0

**TUBE**



\*All dimensions are nominal

Device	Package Name	Package Type	Pins	SPQ	L (mm)	W (mm)	T (μm)	B (mm)
LM2576HVS-12	KTT	TO-263	5	45	502	25	8204.2	9.19
LM2576HVS-12	KTT	TO-263	5	45	502	25	8204.2	9.19
LM2576HVS-12/NOPB	KTT	TO-263	5	45	502	25	8204.2	9.19
LM2576HVS-3.3/NOPB	KTT	TO-263	5	45	502	25	8204.2	9.19
LM2576HVS-5.0	KTT	TO-263	5	45	502	25	8204.2	9.19
LM2576HVS-5.0	KTT	TO-263	5	45	502	25	8204.2	9.19
LM2576HVS-5.0/NOPB	KTT	TO-263	5	45	502	25	8204.2	9.19
LM2576HVS-ADJ	KTT	TO-263	5	45	502	25	8204.2	9.19
LM2576HVS-ADJ	KTT	TO-263	5	45	502	25	8204.2	9.19
LM2576HVS-ADJ/NOPB	KTT	TO-263	5	45	502	25	8204.2	9.19
LM2576HVT-12	KC	TO-220	5	45	502	33	6985	4.06
LM2576HVT-12	KC	TO-220	5	45	502	33	6985	4.06
LM2576HVT-12/LF03	NDH	TO-220	5	45	502	30	30048.2	10.74
LM2576HVT-12/NOPB	KC	TO-220	5	45	502	33	6985	4.06
LM2576HVT-15/LB03	NDH	TO-220	5	45	502	30	30048.2	10.74
LM2576HVT-15/LB03	NDH	TO-220	5	45	502	30	30048.2	10.74
LM2576HVT-15/LF03	NDH	TO-220	5	45	502	30	30048.2	10.74
LM2576HVT-15/NOPB	KC	TO-220	5	45	502	33	6985	4.06
LM2576HVT-5.0	KC	TO-220	5	45	502	33	6985	4.06
LM2576HVT-5.0	KC	TO-220	5	45	502	33	6985	4.06
LM2576HVT-5.0/LB03	NDH	TO-220	5	45	502	30	30048.2	10.74
LM2576HVT-5.0/LB03	NDH	TO-220	5	45	502	30	30048.2	10.74
LM2576HVT-5.0/LF02	NEB	TO-220	5	45	502	30	30048.2	10.74
LM2576HVT-5.0/LF03	NDH	TO-220	5	45	502	30	30048.2	10.74
LM2576HVT-5.0/NOPB	KC	TO-220	5	45	502	33	6985	4.06
LM2576HVT-ADJ	KC	TO-220	5	45	502	33	6985	4.06
LM2576HVT-ADJ	KC	TO-220	5	45	502	33	6985	4.06
LM2576HVT-ADJ/LB03	NDH	TO-220	5	45	502	30	30048.2	10.74
LM2576HVT-ADJ/LB03	NDH	TO-220	5	45	502	30	30048.2	10.74

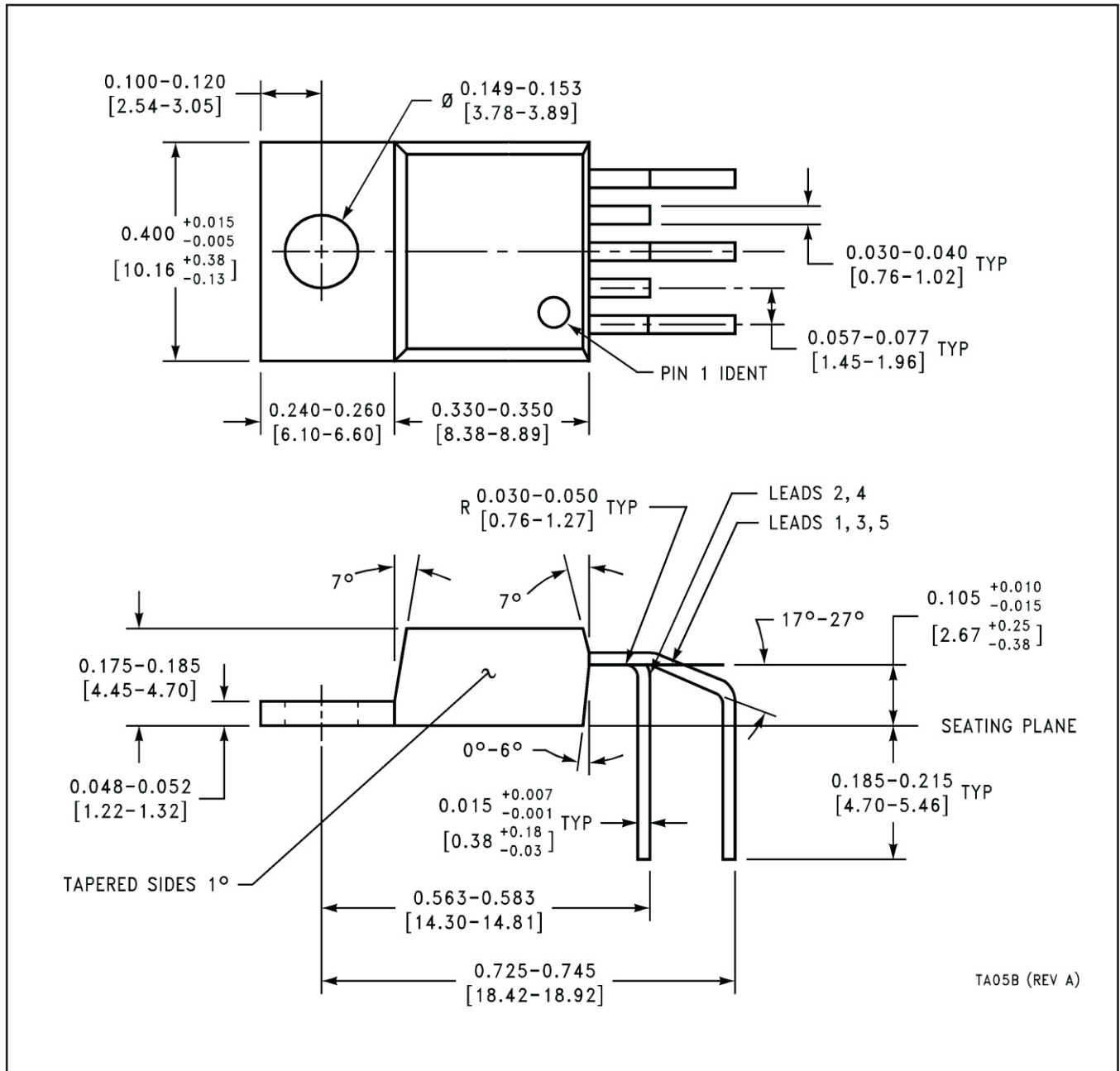

Device	Package Name	Package Type	Pins	SPQ	L (mm)	W (mm)	T (µm)	B (mm)
LM2576HVT-ADJ/LF03	NDH	TO-220	5	45	502	30	30048.2	10.74
LM2576HVT-ADJ/NOPB	KC	TO-220	5	45	502	33	6985	4.06
LM2576S-12	KTT	TO-263	5	45	502	25	8204.2	9.19
LM2576S-12	KTT	TO-263	5	45	502	25	8204.2	9.19
LM2576S-12/NOPB	KTT	TO-263	5	45	502	25	8204.2	9.19
LM2576S-3.3/NOPB	KTT	TO-263	5	45	502	25	8204.2	9.19
LM2576S-5.0	KTT	TO-263	5	45	502	25	8204.2	9.19
LM2576S-5.0	KTT	TO-263	5	45	502	25	8204.2	9.19
LM2576S-5.0/NOPB	KTT	TO-263	5	45	502	25	8204.2	9.19
LM2576S-ADJ/NOPB	KTT	TO-263	5	45	502	25	8204.2	9.19
LM2576T-12	KC	TO-220	5	45	502	33	6985	4.06
LM2576T-12	KC	TO-220	5	45	502	33	6985	4.06
LM2576T-12/LB03	NDH	TO-220	5	45	502	30	30048.2	10.74
LM2576T-12/LB03	NDH	TO-220	5	45	502	30	30048.2	10.74
LM2576T-12/LF03	NDH	TO-220	5	45	502	30	30048.2	10.74
LM2576T-12/NOPB	KC	TO-220	5	45	502	33	6985	4.06
LM2576T-15/LF03	NDH	TO-220	5	45	502	30	30048.2	10.74
LM2576T-15/NOPB	KC	TO-220	5	45	502	33	6985	4.06
LM2576T-3.3/LF03	NDH	TO-220	5	45	502	30	30048.2	10.74
LM2576T-3.3/NOPB	KC	TO-220	5	45	502	33	6985	4.06
LM2576T-5.0	KC	TO-220	5	45	502	33	6985	4.06
LM2576T-5.0	KC	TO-220	5	45	502	33	6985	4.06
LM2576T-5.0/LB03	NDH	TO-220	5	45	502	30	30048.2	10.74
LM2576T-5.0/LB03	NDH	TO-220	5	45	502	30	30048.2	10.74
LM2576T-5.0/LF02	NEB	TO-220	5	45	502	30	30048.2	10.74
LM2576T-5.0/LF03	NDH	TO-220	5	45	502	30	30048.2	10.74
LM2576T-5.0/NOPB	KC	TO-220	5	45	502	33	6985	4.06
LM2576T-ADJ	KC	TO-220	5	45	502	33	6985	4.06
LM2576T-ADJ	KC	TO-220	5	45	502	33	6985	4.06
LM2576T-ADJ/LB03	NDH	TO-220	5	45	502	30	30048.2	10.74
LM2576T-ADJ/LB03	NDH	TO-220	5	45	502	30	30048.2	10.74
LM2576T-ADJ/LF02	NEB	TO-220	5	45	502	30	30048.2	10.74
LM2576T-ADJ/LF03	NDH	TO-220	5	45	502	30	30048.2	10.74
LM2576T-ADJ/NOPB	KC	TO-220	5	45	502	33	6985	4.06

NEB0005B



# KC0005A



# PACKAGE OUTLINE

TO-220 - 16.51 mm max height

TO-220

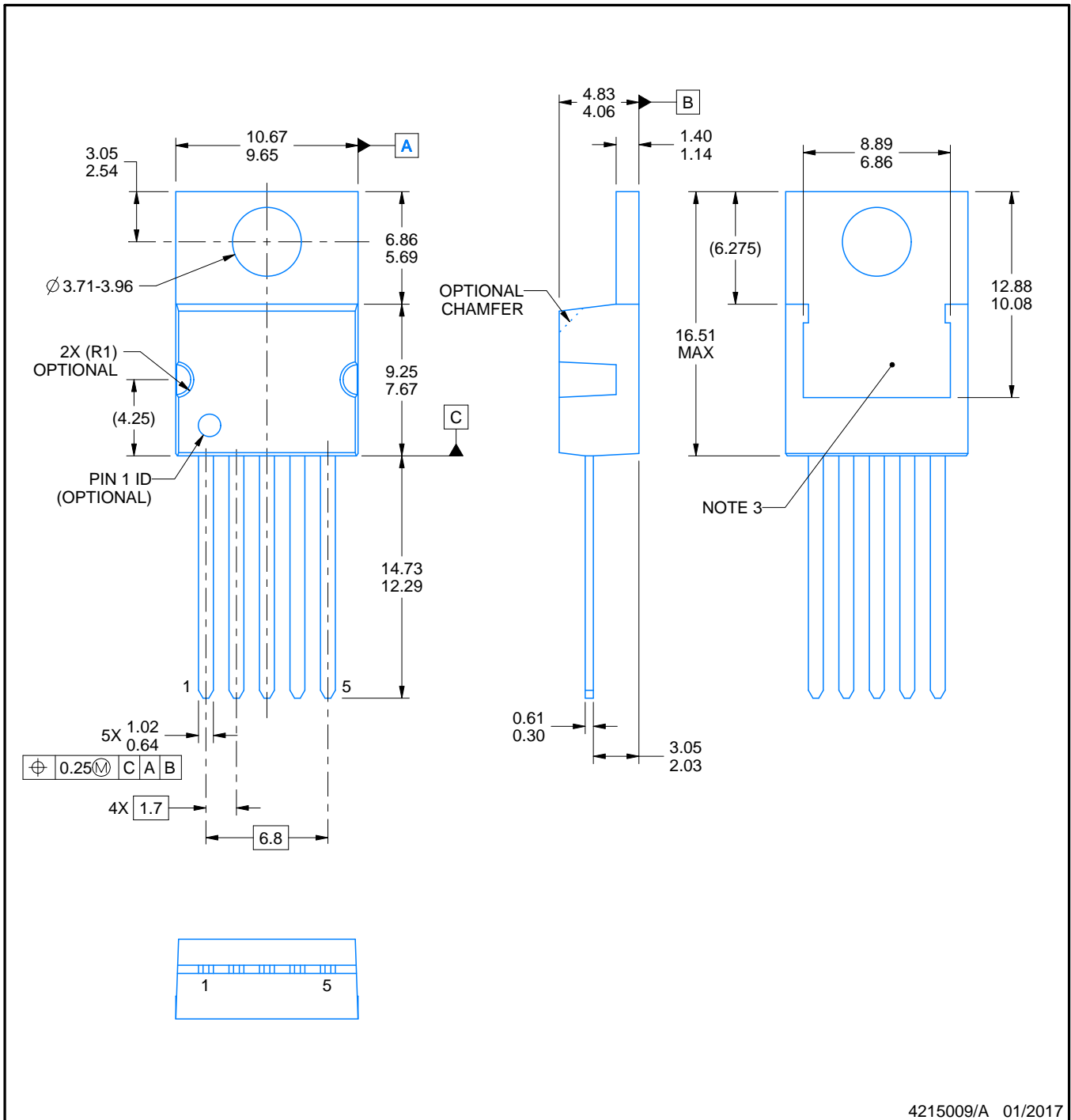

NOTES:

1. All controlling linear dimensions are in inches. Dimensions in brackets are in millimeters. Any dimension in brackets or parenthesis are for reference only. Dimensioning and tolerancing per ASME Y14.5M.
2. This drawing is subject to change without notice.
3. Shape may vary per different assembly sites.

# EXAMPLE BOARD LAYOUT

KC0005A

TO-220 - 16.51 mm max height

TO-220

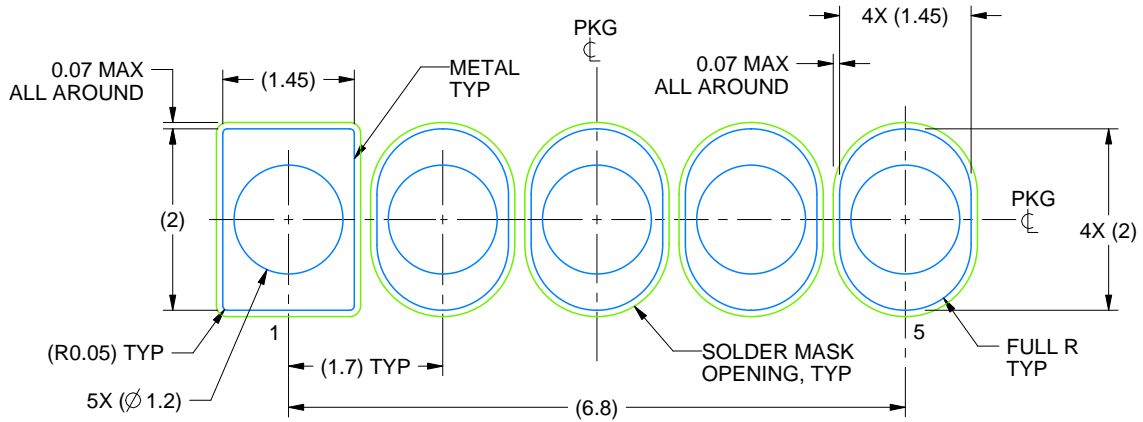

LAND PATTERN  
NON-SOLDER MASK DEFINED  
SCALE:12X

4215009/A 01/2017

NDH0005D

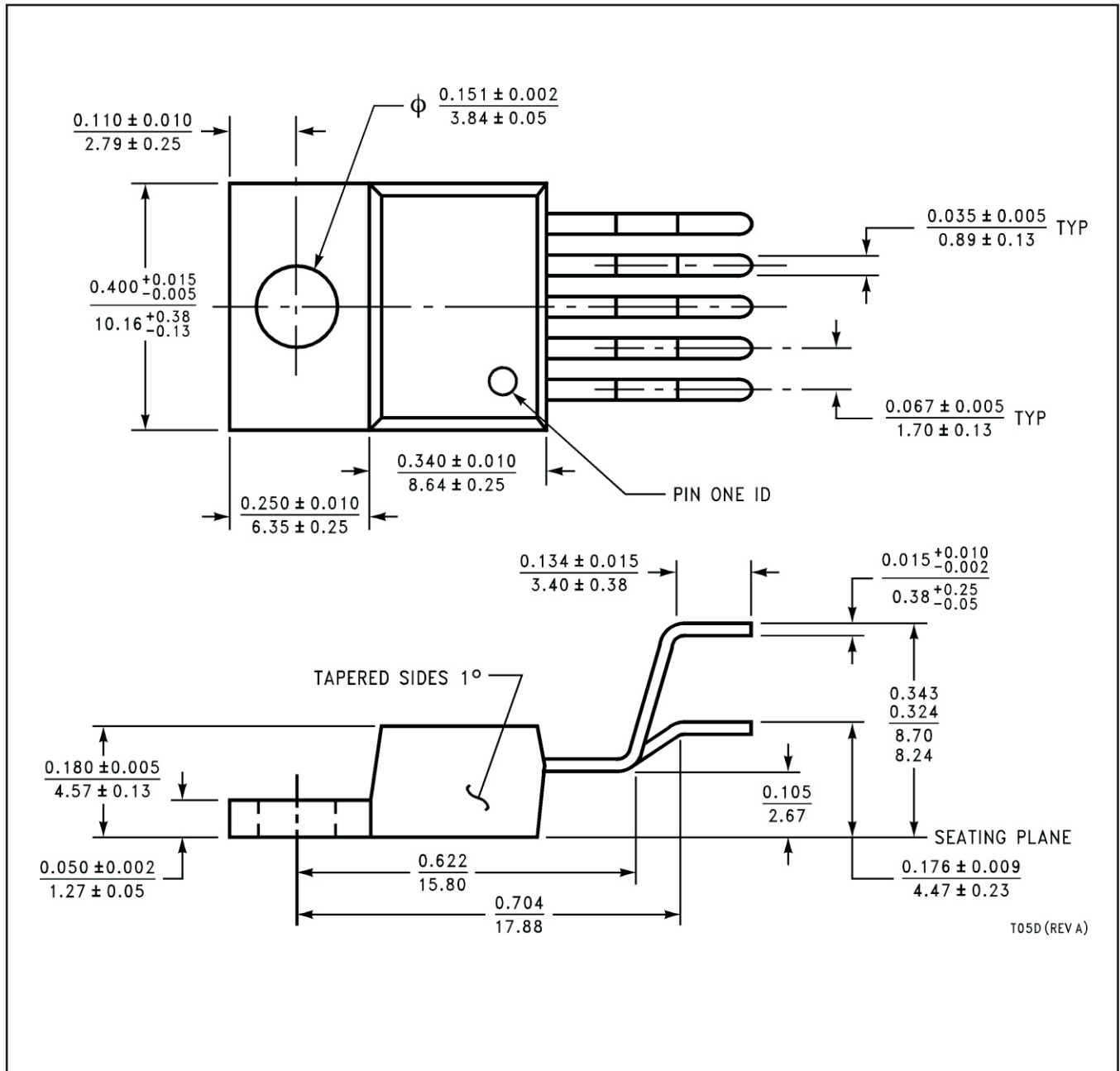

T05D (REV A)

KTT (R-PSFM-G5)

PLASTIC FLANGE-MOUNT PACKAGE



- NOTES:
- A. All linear dimensions are in millimeters.
  - B. This drawing is subject to change without notice.
  - C. Body dimensions do not include mold flash or protrusion. Mold flash or protrusion not to exceed 0.005 (0,13) per side.
- △ Falls within JEDEC TO-263 variation BA, except minimum lead thickness, maximum seating height, and minimum body length.

## 重要なお知らせと免責事項

TI は、技術データと信頼性データ (データシートを含みます)、設計リソース (リファレンス・デザインを含みます)、アプリケーションや設計に関する各種アドバイス、Web ツール、安全性情報、その他のリソースを、欠陥が存在する可能性のある「現状のまま」提供しており、商品性および特定目的に対する適合性の黙示保証、第三者の知的財産権の非侵害保証を含むいかなる保証も、明示的または黙示的にかかわらず拒否します。

これらのリソースは、TI 製品を使用する設計の経験を積んだ開発者への提供を意図したものです。(1) お客様のアプリケーションに適した TI 製品の選定、(2) お客様のアプリケーションの設計、検証、試験、(3) お客様のアプリケーションに該当する各種規格や、その他のあらゆる安全性、セキュリティ、規制、または他の要件への確実な適合に関する責任を、お客様のみが単独で負うものとし、

上記の各種リソースは、予告なく変更される可能性があります。これらのリソースは、リソースで説明されている TI 製品を使用するアプリケーションの開発の目的でのみ、TI はその使用をお客様に許諾します。これらのリソースに関して、他の目的で複製することや掲載することは禁止されています。TI や第三者の知的財産権のライセンスが付与されている訳ではありません。お客様は、これらのリソースを自身で使用した結果発生するあらゆる申し立て、損害、費用、損失、責任について、TI およびその代理人を完全に補償するものとし、TI は一切の責任を拒否します。

TI の製品は、[TI の販売条件](#)、または [ti.com](#) やかかる TI 製品の関連資料などのいずれかを通じて提供する適用可能な条項の下で提供されています。TI がこれらのリソースを提供することは、適用される TI の保証または他の保証の放棄の拡大や変更を意味するものではありません。

お客様がいかなる追加条項または代替条項を提案した場合でも、TI はそれらに異議を唱え、拒否します。

郵送先住所 : Texas Instruments, Post Office Box 655303, Dallas, Texas 75265  
Copyright © 2024, Texas Instruments Incorporated