

LM386 低電圧オーディオ・パワー・アンプ

1 特長

- ・ バッテリでの動作
- ・ 必要な外付け部品が最小限
- ・ 広い電源電圧範囲: 4V~12V または 5V~18V
- ・ 低い静止電流消費: 4mA
- ・ 20~200 の電圧ゲイン
- ・ 入力はグラウンドが基準
- ・ 出力静止電圧の自己センタリング
- ・ 低歪: 0.2% ($A_V = 20$, $V_S = 6V$, $R_L = 8\Omega$, $P_O = 125mW$, $f = 1kHz$)
- ・ 8ピンの MSOP パッケージで供給

2 アプリケーション

- ・ AM/FM ラジオのアンプ
- ・ 携帯テープ・プレーヤのアンプ
- ・ インターコム
- ・ テレビ用サウンド・システム
- ・ ライン・ドライバ
- ・ 超音波ドライバ
- ・ 小型サーボ・ドライバ
- ・ パワー・コンバータ

3 概要

LM386M-1 および LM386MX-1 は、低電圧の消費者向けアプリケーションで使用するよう設計されたパワー・アンプです。外付け部品数を減らすため、ゲインは内部的に 20 に設定されていますが、ピン 1 と 8 との間に外付け抵抗とコンデンサを追加すると、20~200 の任意の値にゲインを増大できます。

入力はグラウンドを基準とし、出力は自動的に電源電圧の半分にバイアスされます。静止時の消費電力は 6V 電源での動作時にわずか 24mW であるため、LM386M-1 および LM386MX-1 はバッテリーでの動作に適しています。

製品情報(1)

部品番号	パッケージ	本体サイズ (公称)
LM386N-1	PDIP (8)	9.60mm × 6.35mm
LM386N-3	PDIP (8)	9.60mm × 6.35mm
LM386N-4	PDIP (8)	9.60mm × 6.35mm
LM386M-1	SOIC (8)	4.90mm × 3.90mm
LM386MX-1	SOIC (8)	4.90mm × 3.90mm
LM386MMX-1	VSSOP (8)	3.00mm × 3.00mm

(1) 利用可能なすべてのパッケージについては、データシートの末尾にある注文情報を参照してください。

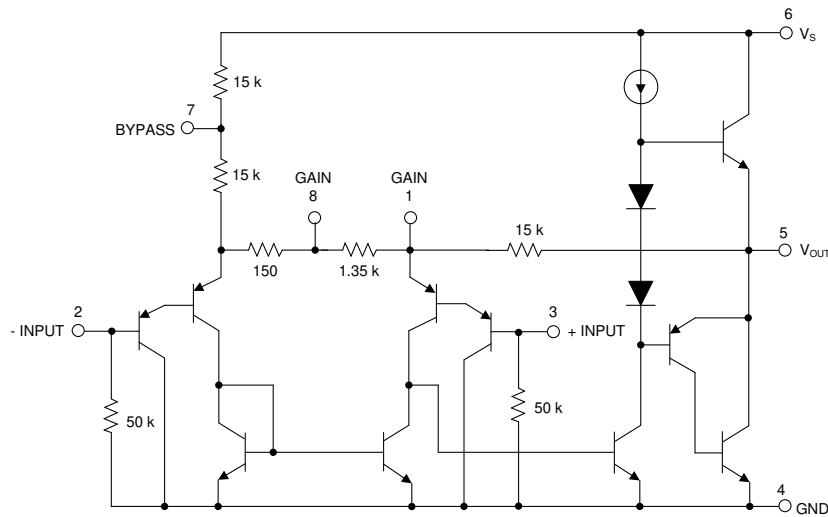

回路図



Table of Contents

1 特長.....	1	8.3 Feature Description.....	9
2 アプリケーション.....	1	8.4 Device Functional Modes.....	9
3 概要.....	1	9 Application and Implementation.....	10
4 Revision History.....	2	9.1 Application Information.....	10
5 Pin Configuration and Functions.....	3	9.2 Typical Application.....	10
6 Specifications.....	4	10 Power Supply Recommendations.....	17
6.1 Absolute Maximum Ratings.....	4	11 Layout.....	18
6.2 ESD Ratings.....	4	11.1 Layout Guidelines.....	18
6.3 Recommended Operating Conditions.....	4	11.2 Layout Examples.....	18
6.4 Thermal Information.....	4	12 Device and Documentation Support.....	20
6.5 Electrical Characteristics.....	5	12.1 Device Support.....	20
6.6 Typical Characteristics.....	6	12.2 Documentation Support.....	20
7 Parameter Measurement Information.....	8	12.3 Receiving Notification of Documentation Updates.....	20
8 Detailed Description.....	9	12.4 Community Resources.....	20
8.1 Overview.....	9	12.5 Trademarks.....	20
8.2 Functional Block Diagram.....	9		

4 Revision History

資料番号末尾の英字は改訂を表しています。その改訂履歴は英語版に準じています。

Changes from Revision C (May 2017) to Revision D (August 2023)	Page
• Updated Typical Output Power Spec.....	5

Changes from Revision B (March 2017) to Revision C (May 2017)	Page
• データシートのタイトルでデバイス LM386M-1/LM386MX-1 を LM386 に変更.....	1
• ドキュメント全体にわたって表、図、相互参照の採番方法を更新.....	1
• Changed From: LM386N-4 To: Speaker Impedance in the <i>Recommended Operating Conditions</i> table.....	4
• Changed From: 5 Ω to 12 Ω To: 5 V to 12 V for Supply Voltage in 表 9-1	10
• Changed kW To: kΩ in the <i>Gain Control</i> section.....	10
• Changed kW To: kΩ in the <i>Input Biasing</i> section.....	11
• Changed 図 9-2	11
• Changed From: 5 Ω to 12 Ω To: 5 V to 12 V for Supply Voltage in 表 9-2	12
• Changed 図 9-4	12
• Changed From: 5 Ω to 12 Ω To: 5 V to 12 V for Supply Voltage in 表 9-3	13
• Changed 図 9-6	13
• Changed From: 5 Ω to 12 Ω To: 5 V to 12 V for Supply Voltage in 表 9-4	14
• Changed 図 9-8	14
• Changed From: 5 Ω to 12 Ω To: 5 V to 12 V for Supply Voltage in 表 9-5	15
• Changed From: 5 Ω to 12 Ω To: 5 V to 12 V for Supply Voltage in 表 9-6	16
• Changed 図 9-12	16
• Changed From: 5 Ω to 12 Ω To: 5 V to 12 V for Supply Voltage in 表 9-7	17
• Changed 図 9-14	17

Changes from Revision A (May 2004) to Revision B (March 2017)	Page
• LM386MX-1 デバイスをデータシートに追加.....	1
• 「製品情報」、「アプリケーションと実装」、「電源に関する推奨事項」、「レイアウト」、「デバイスおよびドキュメントのサポート」の各セクションを追加.....	1
• Inserted Functional Block Diagram.....	9

5 Pin Configuration and Functions



图 5-1. D Package 8-Pin MSOP Top View

表 5-1. Pin Functions

PIN		TYPE ⁽¹⁾	DESCRIPTION
NAME	NO.		
GAIN	1	–	Gain setting pin
–INPUT	2	I	Inverting input
+INPUT	3	I	Noninverting input
GND	4	P	Ground reference
V _{OUT}	5	O	Output
V _S	6	P	Power supply voltage
BYPASS	7	O	Bypass decoupling path
GAIN	8	–	Gain setting pin

(1) I = Input, O = Output, P = Power

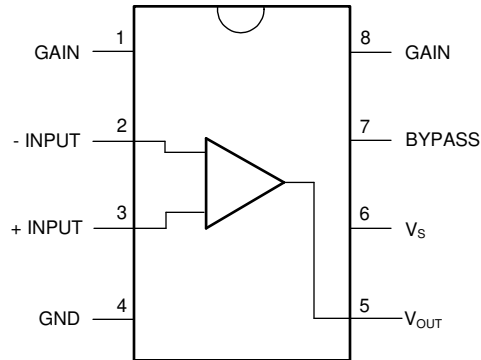
6 Specifications

6.1 Absolute Maximum Ratings

over operating free-air temperature range (unless otherwise noted)⁽¹⁾

		MIN	MAX	UNIT
Supply Voltage, V_{CC}	LM386N-1/-3, LM386M-1		15	V
	LM386N-4		22	
Package Dissipation	LM386N		1.25	W
	LM386M		0.73	
	LM386MM-1		0.595	
Input Voltage, V_I		-0.4	0.4	V
Storage temperature, T_{stg}		-65	150	°C

- (1) Stresses beyond those listed under *Absolute Maximum Ratings* may cause permanent damage to the device. These are stress ratings only, which do not imply functional operation of the device at these or any other conditions beyond those indicated under *Recommended Operating Conditions*. Exposure to absolute-maximum-rated conditions for extended periods may affect device reliability.

6.2 ESD Ratings

		VALUE	UNIT
$V_{(ESD)}$ Electrostatic discharge	Human-body model (HBM), per ANSI/ESDA/JEDEC JS-001 ⁽¹⁾	±1000	V
	Charged-device model (CDM), per JEDEC specification JESD22-C101 ⁽²⁾	±1000	

- (1) JEDEC document JEP155 states that 500-V HBM allows safe manufacturing with a standard ESD control process.
 (2) JEDEC document JEP157 states that 250-V CDM allows safe manufacturing with a standard ESD control process.

6.3 Recommended Operating Conditions

over operating free-air temperature range (unless otherwise noted)

		MIN	NOM	MAX	UNIT
V_{CC}	Supply Voltage	4		12	V
	LM386N-4	5		18	V
	Speaker Impedance	4			Ω
V_I	Analog input voltage	-0.4		0.4	V
TA	Operating free-air temperature	0		70	°C

6.4 Thermal Information

THERMAL METRIC ⁽¹⁾		LM386	LM386	LM386	UNIT
		D (SOIC)	DGK (VSSOP)	P (PDIP)	
		8	8	8	
$R_{\theta JA}$	Junction-to-ambient thermal resistance	115.7	169.3	53.4	°C/W
$R_{\theta JC(top)}$	Junction-to-case (top) thermal resistance	59.7	73.1	42.1	°C/W
$R_{\theta JB}$	Junction-to-board thermal resistance	56.2	100.2	30.6	°C/W
Ψ_{JT}	Junction-to-top characterization parameter	12.4	9.2	19.0	°C/W
Ψ_{JB}	Junction-to-board characterization parameter	55.6	99.1	50.5	°C/W

- (1) For more information about traditional and new thermal metrics, see the [Semiconductor and IC Package Thermal Metrics](#) application report.

6.5 Electrical Characteristics

over operating free-air temperature range (unless otherwise noted)

PARAMETER		TEST CONDITIONS	MIN	TYP	MAX	UNIT
V _S	Operating Supply Voltage	LM386N-1, -3, LM386M-1, LM386MM-1	4		12	V
		LM386N-4	5		18	
I _Q	Quiescent Current	V _S = 6 V, V _{IN} = 0		4	8	mA
P _{OUT}	Output Power	V _S = 6 V, R _L = 8 Ω, THD = 10% (LM386N-1, LM386M-1, LM386MM-1)	250	325		mW
		V _S = 9 V, R _L = 8 Ω, THD = 10% (LM386N-3)	500	700		
		V _S = 16 V, R _L = 32 Ω, THD = 10% (LM386N-4)	700	1000		
A _V	Voltage Gain	V _S = 6 V, f = 1 kHz		26		dB
		10 μF from Pin 1 to 8		46		
BW	Bandwidth	V _S = 6 V, Pins 1 and 8 Open		300		kHz
THD	Total Harmonic Distortion	V _S = 6 V, R _L = 8 Ω, P _{OUT} = 125 mW f = 1 kHz, Pins 1 and 8 Open		0.2%		
PSRR	Power Supply Rejection Ratio	V _S = 6 V, f = 1 kHz, CBYPASS = 10 μF Pins 1 and 8 Open, Referred to Output		50		dB
R _{IN}	Input Resistance			50		kΩ
I _{BIAS}	Input Bias Current	V _S = 6 V, Pins 2 and 3 Open		250		nA

6.6 Typical Characteristics



图 6-1. Supply Current vs Supply Voltage



图 6-2. Power Supply Rejection vs Frequency

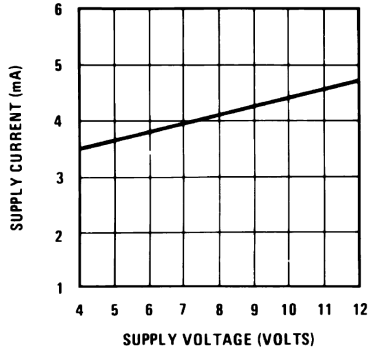

图 6-3. Output Voltage vs Supply Voltage

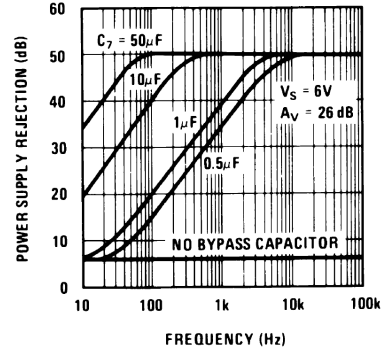

图 6-4. Voltage Gain vs Frequency

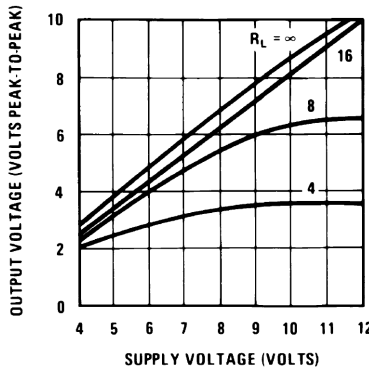

图 6-5. Total Harmonic Distortion vs Frequency

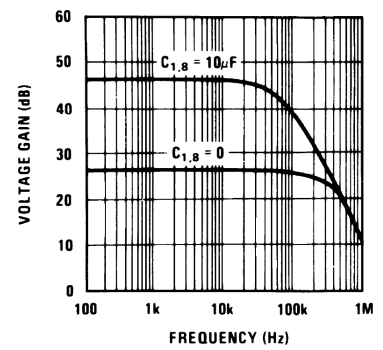

图 6-6. Total Harmonic Distortion vs Power Out

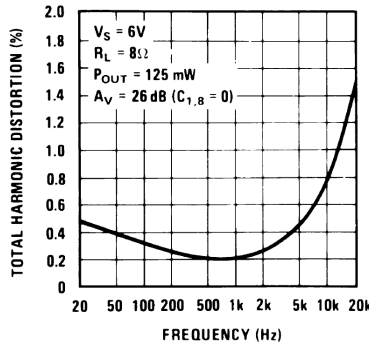

图 6-7. Device Dissipation vs Output Power

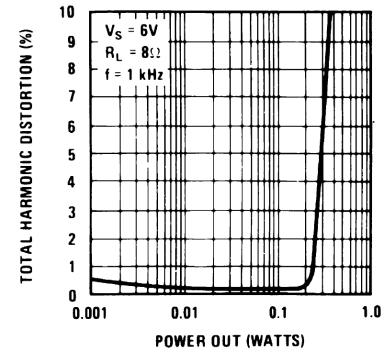

图 6-8. Device Dissipation vs Output Power

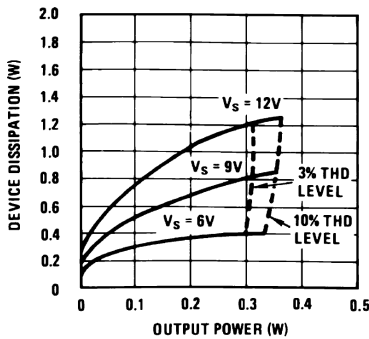

6-9. Device Dissipation vs Output Power

7 Parameter Measurement Information

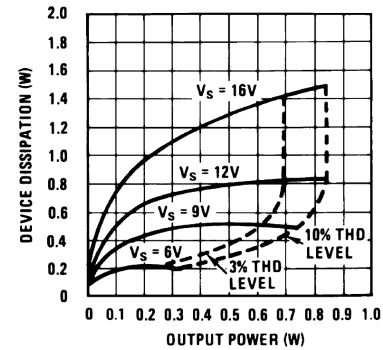
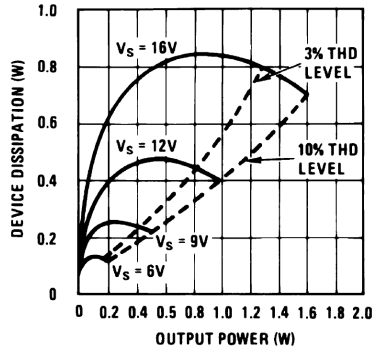
All parameters are measured according to the conditions described in the [セクション 6](#) section.

8 Detailed Description

8.1 Overview

The LM386 is a mono low voltage amplifier that can be used in a variety of applications. It can drive loads from 4 Ω to 32 Ω . The gain is internally set to 20 but it can be modified from 20 to 200 by placing a resistor and capacitor between pins 1 and 8. This device comes in three different 8-pin packages as PDIP, SOIC and VSSOP to fit in different applications.

8.2 Functional Block Diagram

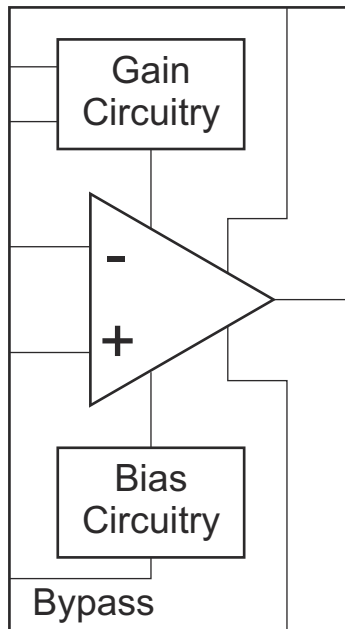

8.3 Feature Description

There is an internal 1.35-K Ω resistor that sets the gain of this device to 20. The gain can be modified from 20 to 200. Detailed information about gain setting can be found in the [セクション 9.2.2.2](#) section.

8.4 Device Functional Modes

As this is an Op Amp it can be used in different configurations to fit in several applications. The internal gain setting resistor allows the LM386 to be used in a very low part count system. In addition a series resistor can be placed between pins 1 and 5 to modify the gain and frequency response for specific applications.

9 Application and Implementation

注

Information in the following applications sections is not part of the TI component specification, and TI does not warrant its accuracy or completeness. TI's customers are responsible for determining suitability of components for their purposes. Customers should validate and test their design implementation to confirm system functionality.

9.1 Application Information

Below are shown different setups that show how the LM386 can be implemented in a variety of applications.

9.2 Typical Application

9.2.1 LM386 with Gain = 20

Figure 9-1 shows the minimum part count application that can be implemented using LM386. Its gain is internally set to 20.

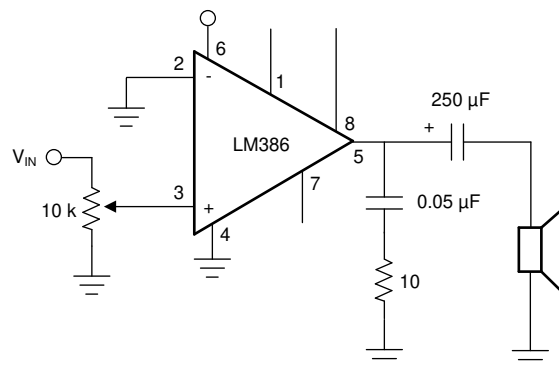

Copyright © 2017, Texas Instruments Incorporated

Figure 9-1. LM386 with Gain = 20

9.2.1.1 Design Requirements

Table 9-1. Design Parameters

DESIGN PARAMETER	EXAMPLE VALUE
Load Impedance	4 Ω to 32 Ω
Supply Voltage	5 V to 12 V

9.2.1.2 Detailed Design Procedure

9.2.1.2.1 Gain Control

To make the LM386 a more versatile amplifier, two pins (1 and 8) are provided for gain control. With pins 1 and 8 open the 1.35-kΩ resistor sets the gain at 20 (26 dB). If a capacitor is put from pin 1 to 8, bypassing the 1.35-kΩ resistor, the gain will go up to 200 (46 dB). If a resistor is placed in series with the capacitor, the gain can be set to any value from 20 to 200. Gain control can also be done by capacitively coupling a resistor (or FET) from pin 1 to ground.

Additional external components can be placed in parallel with the internal feedback resistors to tailor the gain and frequency response for individual applications. For example, we can compensate poor speaker bass response by frequency shaping the feedback path. This is done with a series RC from pin 1 to 5 (paralleling the internal

15-kΩ resistor). For 6 dB effective bass boost: $R \approx 15 \text{ k}\Omega$, the lowest value for good stable operation is $R = 10 \text{ k}\Omega$ if pin 8 is open. If pins 1 and 8 are bypassed then R as low as 2 kΩ can be used. This restriction is because the amplifier is only compensated for closed-loop gains greater than 9.

9.2.1.2.2 Input Biasing

The schematic shows that both inputs are biased to ground with a 50 kΩ resistor. The base current of the input transistors is about 250 nA, so the inputs are at about 12.5 mV when left open. If the dc source resistance driving the LM386 is higher than 250 kΩ it will contribute very little additional offset (about 2.5 mV at the input, 50 mV at the output). If the dc source resistance is less than 10 kΩ, then shorting the unused input to ground will keep the offset low (about 2.5 mV at the input, 50 mV at the output). For dc source resistances between these values we can eliminate excess offset by putting a resistor from the unused input to ground, equal in value to the dc source resistance. Of course all offset problems are eliminated if the input is capacitively coupled.

When using the LM386 with higher gains (bypassing the 1.35 kΩ resistor between pins 1 and 8) it is necessary to bypass the unused input, preventing degradation of gain and possible instabilities. This is done with a 0.1 μF capacitor or a short to ground depending on the dc source resistance on the driven input.

9.2.1.3 Application Curve

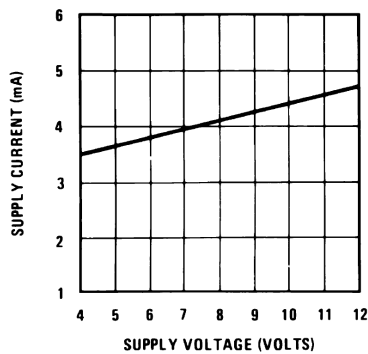

9-2. Supply Current vs Supply Voltage

9.2.2 LM386 with Gain = 200

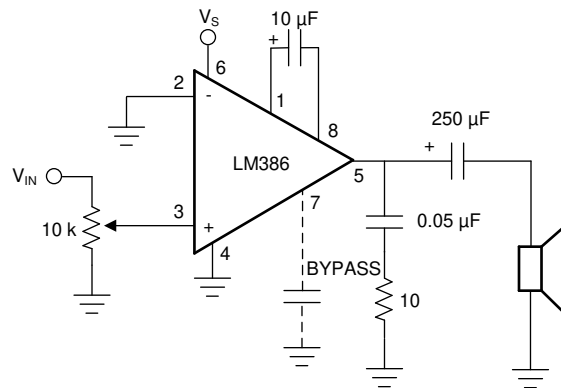

Copyright © 2017, Texas Instruments Incorporated

図 9-3. LM386 with Gain = 200

9.2.2.1 Design Requirements

表 9-2. Design Parameters

DESIGN PARAMETER	EXAMPLE VALUE
Load Impedance	4 Ω to 32 Ω
Supply Voltage	5 V to 12 V

9.2.2.2 Detailed Design Procedure

The Detailed Design Procedure can be found in the [セクション 9.2.1.2](#) section.

9.2.2.3 Application Curve



図 9-4. Supply Current vs Supply Voltage

9.2.3 LM386 with Gain = 50

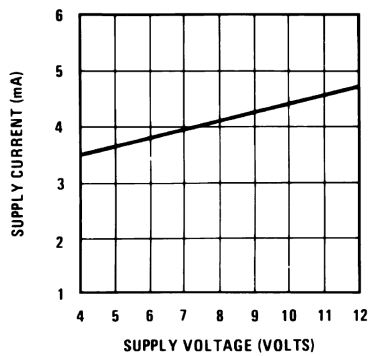
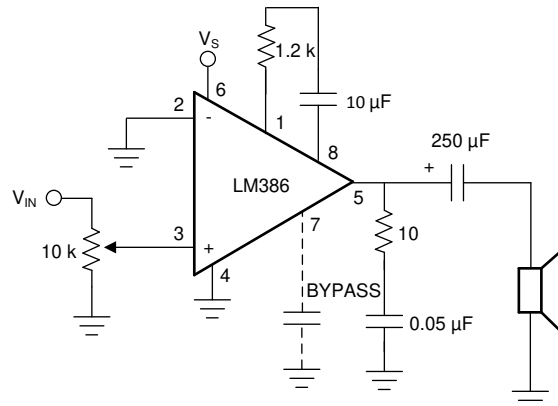

Copyright © 2017, Texas Instruments Incorporated

図 9-5. LM386 with Gain = 50

9.2.3.1 Design Requirements

表 9-3. Design Parameters

DESIGN PARAMETER	EXAMPLE VALUE
Load Impedance	4 Ω to 32 Ω
Supply Voltage	5 V to 12 V

9.2.3.2 Detailed Design Procedure

The Detailed Design Procedure can be found in the [セクション 9.2.1.2](#) section.

9.2.3.3 Application Curve



図 9-6. Supply Current vs Supply Voltage

9.2.4 Low Distortion Power Wienbridge Oscillator

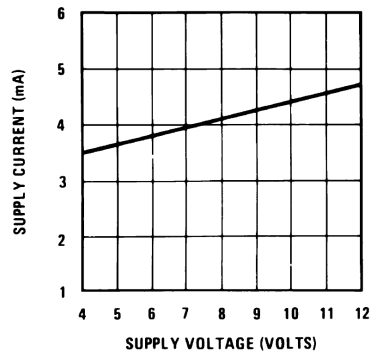

図 9-7. Low Distortion Power Wienbridge Oscillator

9.2.4.1 Design Requirements

表 9-4. Design Parameters

DESIGN PARAMETER	EXAMPLE VALUE
Load Impedance	4 Ω to 32 Ω
Supply Voltage	5 V to 12 V

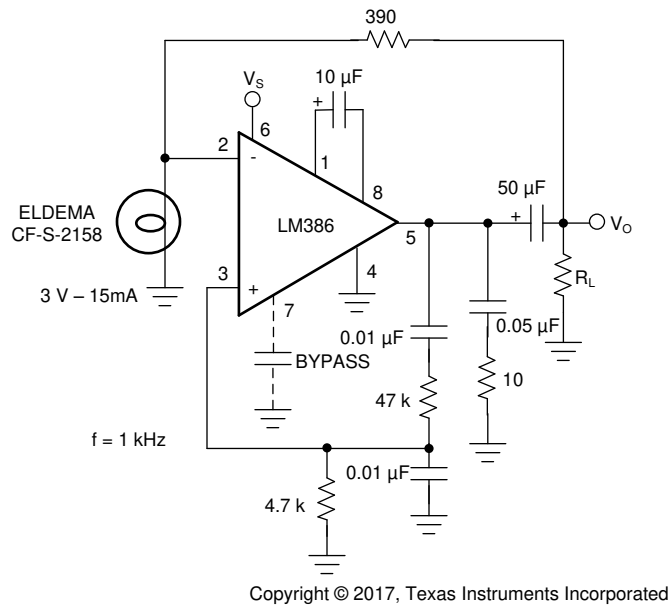
9.2.4.2 Detailed Design Procedure

The Detailed Design Procedure can be found in the [セクション 9.2.1.2](#) section.

9.2.4.3 Application Curve



図 9-8. Supply Current vs Supply Voltage

9.2.5 LM386 with Bass Boost

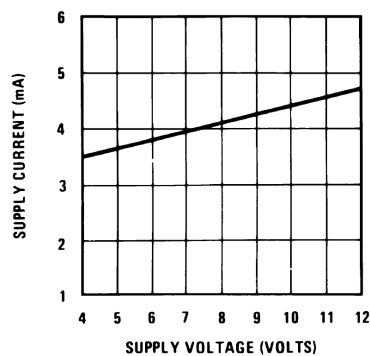
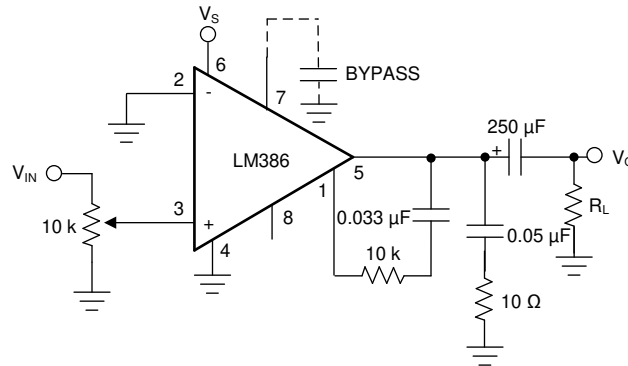

Copyright © 2017, Texas Instruments Incorporated

図 9-9. LM386 with Bass Boost

9.2.5.1 Design Requirements

表 9-5. Design Parameters

DESIGN PARAMETER	EXAMPLE VALUE
Load Impedance	4 Ω to 32 Ω
Supply Voltage	5 V to 12 V

9.2.5.2 Detailed Design Procedure

The Detailed Design Procedure can be found in the [セクション 9.2.1.2](#) section.

9.2.5.3 Application Curve



図 9-10. Voltage Gain vs Frequency

9.2.6 Square Wave Oscillator

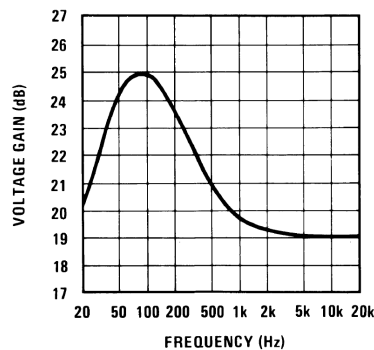
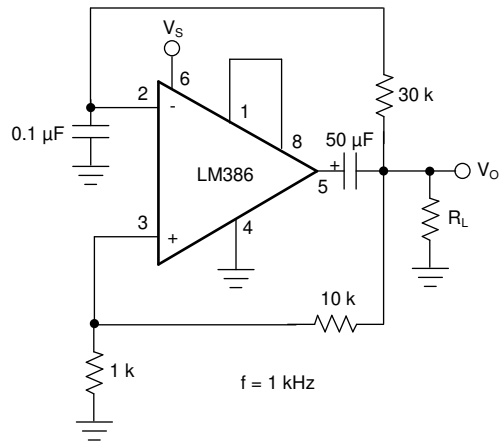

Copyright © 2017, Texas Instruments Incorporated

図 9-11. Square Wave Oscillator

表 9-6. Design Parameters

DESIGN PARAMETER	EXAMPLE VALUE
Load Impedance	4 Ω to 32 Ω
Supply Voltage	5 V to 12 V

9.2.6.1 Detailed Design Procedure

The Detailed Design Procedure can be found in the [セクション 9.2.1.2](#) section.

9.2.6.2 Application Curve



図 9-12. Supply Current vs Supply Voltage

9.2.7 AM Radio Power Amplifier

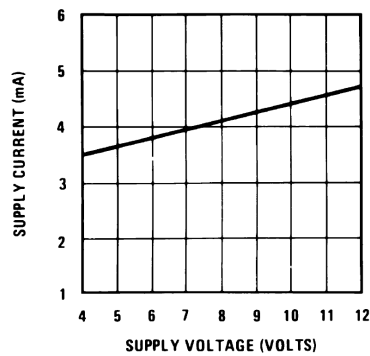
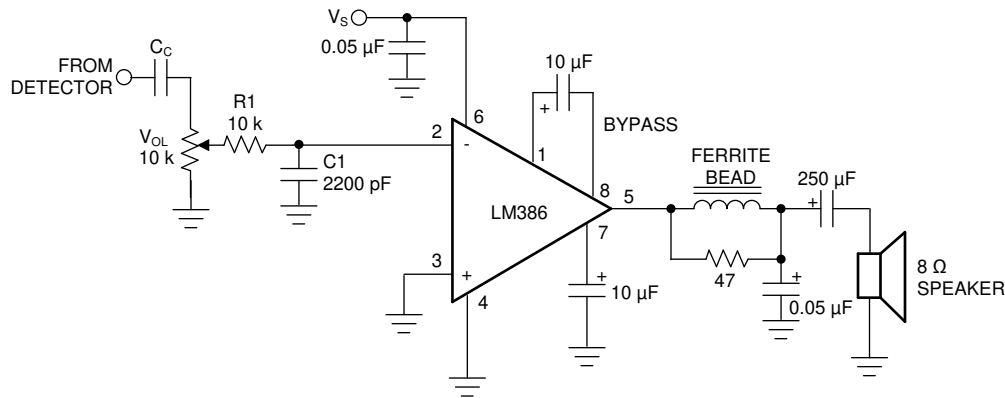

Copyright © 2017, Texas Instruments Incorporated

☒ 9-13. AM Radio Power Amplifier

9.2.7.1 Design Requirements

表 9-7. Design Parameters

DESIGN PARAMETER	EXAMPLE VALUE
Load Impedance	4 Ω to 32 Ω
Supply Voltage	5 V to 12 V

9.2.7.2 Detailed Design Procedure

The Detailed Design Procedure can be found in the [セクション 9.2.1.2](#) section.

9.2.7.3 Application Curve

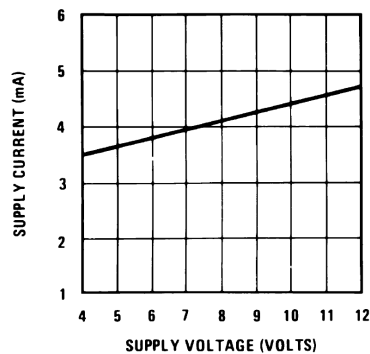

☒ 9-14. Supply Current vs Supply Voltage

10 Power Supply Recommendations

The LM386 is specified for operation up to 12 V or 18 V. The power supply should be well regulated and the voltage must be within the specified values. It is recommended to place a capacitor to GND close to the LM386 power supply pin.

11 Layout

11.1 Layout Guidelines

Place all required components as close as possible to the device. Use short traces for the output to the speaker connection. Route the analog traces far from the digital signal traces and avoid crossing them.

11.2 Layout Examples

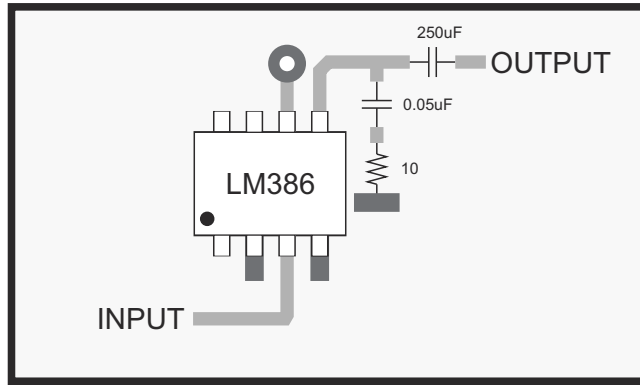

 11-1. Layout Example for Minimum Parts Gain = 20 dB on PDIP package

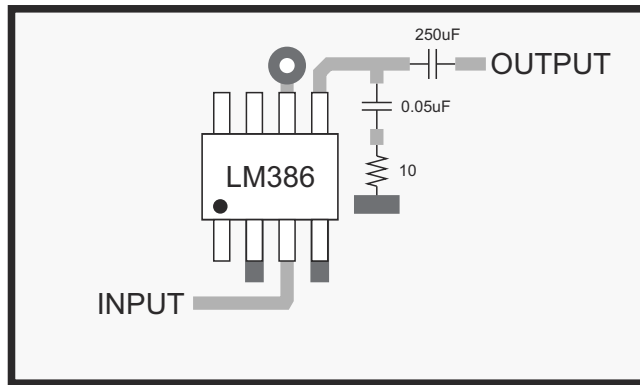

 11-2. Layout Example for Minimum Parts Gain = 20 dB on SOIC package

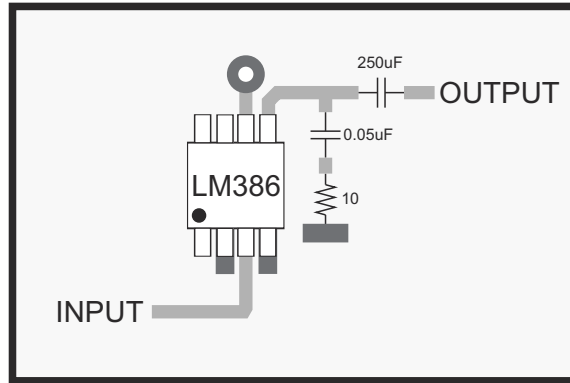

-  Connection to ground plane
-  Connection to power 5V
-  Top layer traces
-  Top layer ground plane

☒ 11-3. Layout Example for Minimum Parts Gain = 20 dB on VSSOP package

12 Device and Documentation Support

12.1 Device Support

12.1.1 Development Support

12.2 Documentation Support

12.3 Receiving Notification of Documentation Updates

To receive notification of documentation updates — go to the product folder for your device on ti.com. In the upper right-hand corner, click the *Alert me* button to register and receive a weekly digest of product information that has changed (if any). For change details, check the revision history of any revised document.

12.4 Community Resources

12.5 Trademarks

すべての商標は、それぞれの所有者に帰属します。

Mechanical, Packaging, and Orderable Information

The following pages include mechanical, packaging, and orderable information. This information is the most current data available for the designated devices. This data is subject to change without notice and revision of this document. For browser-based versions of this data sheet, refer to the left-hand navigation.

PACKAGING INFORMATION

Orderable Device	Status (1)	Package Type	Package Drawing	Pins	Package Qty	Eco Plan (2)	Lead finish/ Ball material (6)	MSL Peak Temp (3)	Op Temp (°C)	Device Marking (4/5)	Samples
LM386M-1/NOPB	ACTIVE	SOIC	D	8	95	RoHS & Green	SN	Level-1-260C-UNLIM	0 to 70	LM386 M-1	Samples
LM386MMX-1/NOPB	ACTIVE	VSSOP	DGK	8	3500	RoHS & Green	SN	Level-1-260C-UNLIM	0 to 70	Z86	Samples
LM386MX-1/NOPB	ACTIVE	SOIC	D	8	2500	RoHS & Green	SN	Level-1-260C-UNLIM	0 to 70	LM386 M-1	Samples
LM386N-1/NOPB	ACTIVE	PDIP	P	8	40	RoHS & Green	NIPDAU	Level-1-NA-UNLIM	0 to 70	LM 386N-1	Samples
LM386N-3/NOPB	ACTIVE	PDIP	P	8	40	RoHS & Green	NIPDAU	Level-1-NA-UNLIM	0 to 70	LM 386N-3	Samples
LM386N-4/NOPB	ACTIVE	PDIP	P	8	40	RoHS & Green	NIPDAU	Level-1-NA-UNLIM	0 to 70	LM 386N-4	Samples

(1) The marketing status values are defined as follows:

ACTIVE: Product device recommended for new designs.

LIFEBUY: TI has announced that the device will be discontinued, and a lifetime-buy period is in effect.

NRND: Not recommended for new designs. Device is in production to support existing customers, but TI does not recommend using this part in a new design.

PREVIEW: Device has been announced but is not in production. Samples may or may not be available.

OBSELETE: TI has discontinued the production of the device.

(2) **RoHS:** TI defines "RoHS" to mean semiconductor products that are compliant with the current EU RoHS requirements for all 10 RoHS substances, including the requirement that RoHS substance do not exceed 0.1% by weight in homogeneous materials. Where designed to be soldered at high temperatures, "RoHS" products are suitable for use in specified lead-free processes. TI may reference these types of products as "Pb-Free".

RoHS Exempt: TI defines "RoHS Exempt" to mean products that contain lead but are compliant with EU RoHS pursuant to a specific EU RoHS exemption.

Green: TI defines "Green" to mean the content of Chlorine (Cl) and Bromine (Br) based flame retardants meet JS709B low halogen requirements of <=1000ppm threshold. Antimony trioxide based flame retardants must also meet the <=1000ppm threshold requirement.

(3) MSL, Peak Temp. - The Moisture Sensitivity Level rating according to the JEDEC industry standard classifications, and peak solder temperature.

(4) There may be additional marking, which relates to the logo, the lot trace code information, or the environmental category on the device.

(5) Multiple Device Markings will be inside parentheses. Only one Device Marking contained in parentheses and separated by a "~" will appear on a device. If a line is indented then it is a continuation of the previous line and the two combined represent the entire Device Marking for that device.

⁽⁶⁾ Lead finish/Ball material - Orderable Devices may have multiple material finish options. Finish options are separated by a vertical ruled line. Lead finish/Ball material values may wrap to two lines if the finish value exceeds the maximum column width.

Important Information and Disclaimer:The information provided on this page represents TI's knowledge and belief as of the date that it is provided. TI bases its knowledge and belief on information provided by third parties, and makes no representation or warranty as to the accuracy of such information. Efforts are underway to better integrate information from third parties. TI has taken and continues to take reasonable steps to provide representative and accurate information but may not have conducted destructive testing or chemical analysis on incoming materials and chemicals. TI and TI suppliers consider certain information to be proprietary, and thus CAS numbers and other limited information may not be available for release.

In no event shall TI's liability arising out of such information exceed the total purchase price of the TI part(s) at issue in this document sold by TI to Customer on an annual basis.

TAPE AND REEL INFORMATION

QUADRANT ASSIGNMENTS FOR PIN 1 ORIENTATION IN TAPE

*All dimensions are nominal

Device	Package Type	Package Drawing	Pins	SPQ	Reel Diameter (mm)	Reel Width W1 (mm)	A0 (mm)	B0 (mm)	K0 (mm)	P1 (mm)	W (mm)	Pin1 Quadrant
LM386MMX-1/NOPB	VSSOP	DGK	8	3500	330.0	12.4	5.3	3.4	1.4	8.0	12.0	Q1
LM386MX-1/NOPB	SOIC	D	8	2500	330.0	12.4	6.5	5.4	2.0	8.0	12.0	Q1

TAPE AND REEL BOX DIMENSIONS

*All dimensions are nominal

Device	Package Type	Package Drawing	Pins	SPQ	Length (mm)	Width (mm)	Height (mm)
LM386MMX-1/NOPB	VSSOP	DGK	8	3500	367.0	367.0	35.0
LM386MX-1/NOPB	SOIC	D	8	2500	367.0	367.0	35.0

TUBE

*All dimensions are nominal

Device	Package Name	Package Type	Pins	SPQ	L (mm)	W (mm)	T (μm)	B (mm)
LM386M-1/NOPB	D	SOIC	8	95	495	8	4064	3.05
LM386N-1/NOPB	P	PDIP	8	40	502	14	11938	4.32
LM386N-3/NOPB	P	PDIP	8	40	502	14	11938	4.32
LM386N-4/NOPB	P	PDIP	8	40	502	14	11938	4.32



D0008A

PACKAGE OUTLINE

SOIC - 1.75 mm max height

SMALL OUTLINE INTEGRATED CIRCUIT



4214825/C 02/2019

NOTES:

- Linear dimensions are in inches [millimeters]. Dimensions in parenthesis are for reference only. Controlling dimensions are in inches. Dimensioning and tolerancing per ASME Y14.5M.
- This drawing is subject to change without notice.
- This dimension does not include mold flash, protrusions, or gate burrs. Mold flash, protrusions, or gate burrs shall not exceed $.006$ [0.15] per side.
- This dimension does not include interlead flash.
- Reference JEDEC registration MS-012, variation AA.

EXAMPLE BOARD LAYOUT

D0008A

SOIC - 1.75 mm max height

SMALL OUTLINE INTEGRATED CIRCUIT



LAND PATTERN EXAMPLE
 EXPOSED METAL SHOWN
 SCALE:8X



SOLDER MASK DETAILS

4214825/C 02/2019

NOTES: (continued)

- 6. Publication IPC-7351 may have alternate designs.
- 7. Solder mask tolerances between and around signal pads can vary based on board fabrication site.

EXAMPLE STENCIL DESIGN

D0008A

SOIC - 1.75 mm max height

SMALL OUTLINE INTEGRATED CIRCUIT



SOLDER PASTE EXAMPLE
BASED ON .005 INCH [0.125 MM] THICK STENCIL
SCALE:8X

4214825/C 02/2019

NOTES: (continued)

8. Laser cutting apertures with trapezoidal walls and rounded corners may offer better paste release. IPC-7525 may have alternate design recommendations.
9. Board assembly site may have different recommendations for stencil design.

P (R-PDIP-T8)

PLASTIC DUAL-IN-LINE PACKAGE

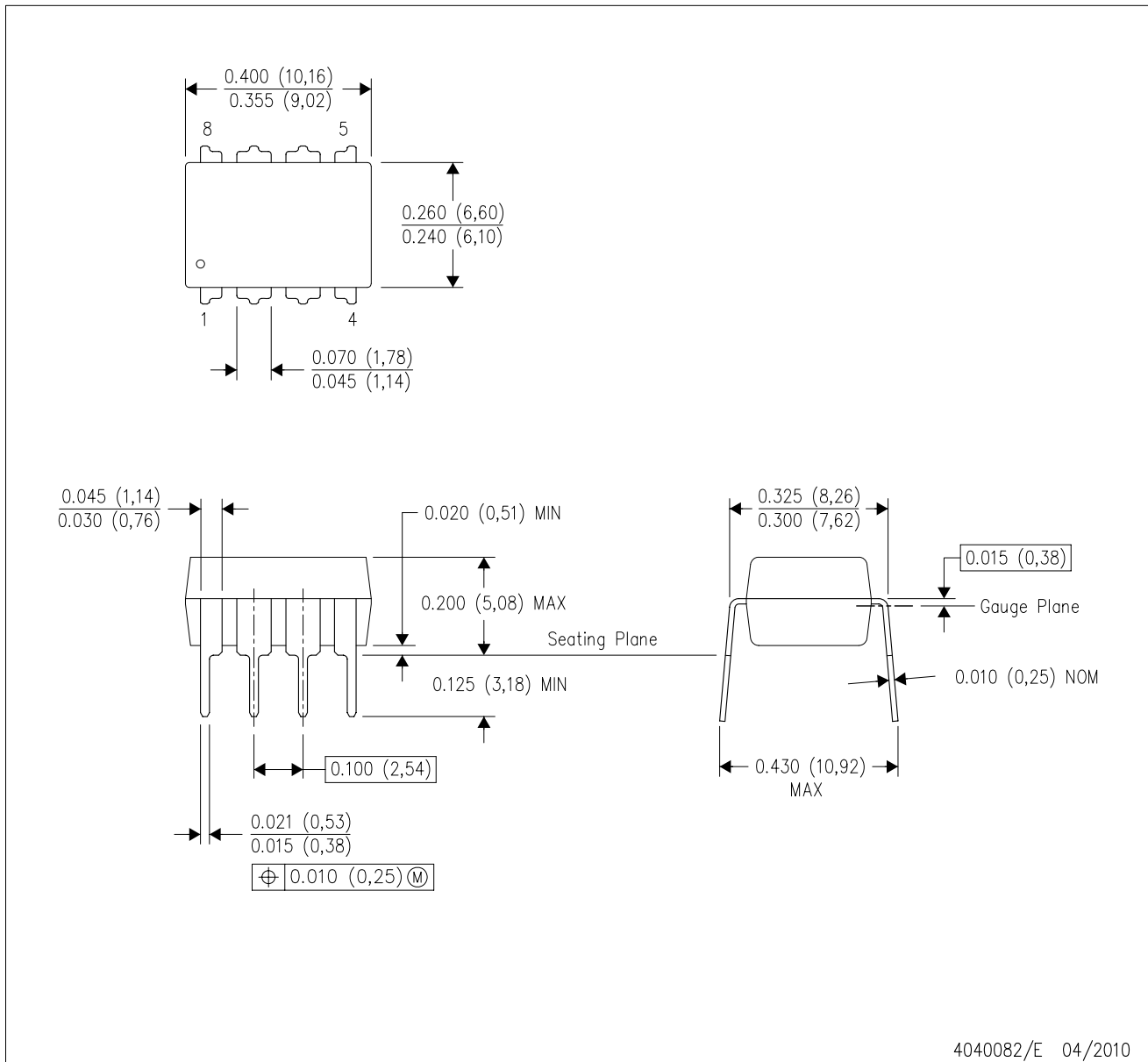

4040082/E 04/2010

- NOTES:
- A. All linear dimensions are in inches (millimeters).
 - B. This drawing is subject to change without notice.
 - C. Falls within JEDEC MS-001 variation BA.

DGK0008A



PACKAGE OUTLINE

VSSOP - 1.1 mm max height

SMALL OUTLINE PACKAGE



4214862/A 04/2023

NOTES:

PowerPAD is a trademark of Texas Instruments.

1. All linear dimensions are in millimeters. Any dimensions in parenthesis are for reference only. Dimensioning and tolerancing per ASME Y14.5M.
2. This drawing is subject to change without notice.
3. This dimension does not include mold flash, protrusions, or gate burrs. Mold flash, protrusions, or gate burrs shall not exceed 0.15 mm per side.
4. This dimension does not include interlead flash. Interlead flash shall not exceed 0.25 mm per side.
5. Reference JEDEC registration MO-187.

EXAMPLE BOARD LAYOUT

DGK0008A

™ VSSOP - 1.1 mm max height

SMALL OUTLINE PACKAGE



LAND PATTERN EXAMPLE
EXPOSED METAL SHOWN
SCALE: 15X



SOLDER MASK DETAILS

4214862/A 04/2023

NOTES: (continued)

6. Publication IPC-7351 may have alternate designs.
7. Solder mask tolerances between and around signal pads can vary based on board fabrication site.
8. Vias are optional depending on application, refer to device data sheet. If any vias are implemented, refer to their locations shown on this view. It is recommended that vias under paste be filled, plugged or tented.
9. Size of metal pad may vary due to creepage requirement.

EXAMPLE STENCIL DESIGN

DGK0008A

TM VSSOP - 1.1 mm max height

SMALL OUTLINE PACKAGE



SOLDER PASTE EXAMPLE
SCALE: 15X

4214862/A 04/2023

NOTES: (continued)

11. Laser cutting apertures with trapezoidal walls and rounded corners may offer better paste release. IPC-7525 may have alternate design recommendations.
12. Board assembly site may have different recommendations for stencil design.

重要なお知らせと免責事項

TI は、技術データと信頼性データ(データシートを含みます)、設計リソース(リファレンス・デザインを含みます)、アプリケーションや設計に関する各種アドバイス、Web ツール、安全性情報、その他のリソースを、欠陥が存在する可能性のある「現状のまま」提供しており、商品性および特定目的に対する適合性の黙示保証、第三者の知的財産権の非侵害保証を含むいかなる保証も、明示的または黙示的にかかわらず拒否します。

これらのリソースは、TI 製品を使用する設計の経験を積んだ開発者への提供を意図したものです。(1) お客様のアプリケーションに適した TI 製品の選定、(2) お客様のアプリケーションの設計、検証、試験、(3) お客様のアプリケーションに該当する各種規格や、その他のあらゆる安全性、セキュリティ、規制、または他の要件への確実な適合に関する責任を、お客様のみが単独で負うものとし、

上記の各種リソースは、予告なく変更される可能性があります。これらのリソースは、リソースで説明されている TI 製品を使用するアプリケーションの開発の目的でのみ、TI はその使用をお客様に許諾します。これらのリソースに関して、他の目的で複製することや掲載することは禁止されています。TI や第三者の知的財産権のライセンスが付与されている訳ではありません。お客様は、これらのリソースを自身で使用した結果発生するあらゆる申し立て、損害、費用、損失、責任について、TI およびその代理人を完全に補償するものとし、TI は一切の責任を拒否します。

TI の製品は、[TI の販売条件](#)、または [ti.com](#) やかかる TI 製品の関連資料などのいずれかを通じて提供する適用可能な条項の下で提供されています。TI がこれらのリソースを提供することは、適用される TI の保証または他の保証の放棄の拡大や変更を意味するものではありません。

お客様がいかなる追加条項または代替条項を提案した場合でも、TI はそれらに異議を唱え、拒否します。

郵送先住所 : Texas Instruments, Post Office Box 655303, Dallas, Texas 75265
Copyright © 2024, Texas Instruments Incorporated