

LM5017 100V、600mA、コンスタント・オンタイム方式同期整流降圧 / Fly-Buck[™] レギュレータ

1 特長

- 7.5V～100V の広い入力電圧範囲
- 100V のハイサイドおよびローサイド・スイッチを内蔵
- ショットキー不要
- コンスタント・オンタイム制御
- ループ補償が不要
- 超高速の過渡応答
- ほぼ一定の動作周波数
- インテリジェントなピーク電流制限
- 出力電圧を 1.225V 以上で調整可能
- 2% の高精度帰還基準電圧
- 周波数を最大 1MHz まで調整可能
- 調整可能な低電圧誤動作防止 (UVLO)
- リモート・シャットダウン
- サーマル・シャットダウン
- パッケージ:
 - WSON-8
 - SO PowerPAD[™]-8
- WEBENCH[®] Power Designer** を使用してカスタム・レギュレータ設計を作成

2 アプリケーション

- 産業用プログラマブル・ロジック・コントローラ (PLC)
- スマート電力メータ
- テレコムの 1 次側 / 2 次側バイアス
- 低消費電力の絶縁 DC/DC (Fly-Buck[™])

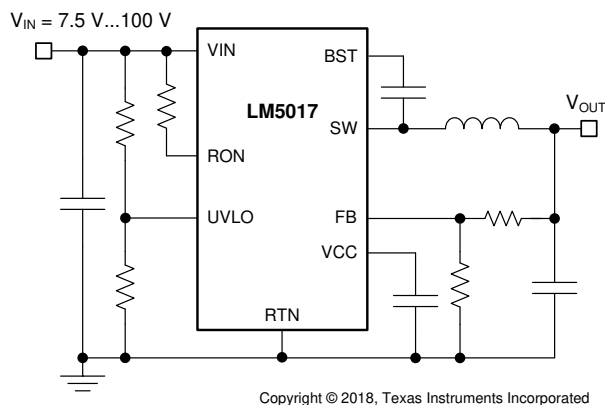

代表的な同期整流降圧アプリケーション回路

3 説明

LM5017 は 100V、600mA の同期整流降圧型レギュレータで、ハイサイドとローサイドの MOSFET が内蔵されています。LM5017 に採用されているコンスタント・オンタイム (COT) 制御方式はループ補償が必要なく、過渡応答が非常に優れており、非常に高い降圧率を実現できます。オンタイムは入力電圧に反比例して変化し、入力電圧範囲の全体にわたって、周波数はほぼ一定に維持されます。高電圧のスタートアップ・レギュレータにより、IC の内部動作および内蔵ゲート・ドライバ用にバイアス電力が供給されます。

ピーク電流制限回路により、過負荷状態から保護します。低電圧誤動作防止 (UVLO) 回路は、入力低電圧スレッシュホールドとヒステリシスを別々にプログラム可能です。その他の保護機能として、サーマル・シャットダウンとバイアス電源低電圧誤動作防止 (V_{CC} UVLO) が搭載されています。

LM5017 は、WSON-8 および HSOP PowerPAD-8 プラスタック・パッケージで供給されます。

製品情報

部品番号	パッケージ ⁽¹⁾	本体サイズ (公称)
LM5017	SO PowerPAD (8)	4.89mm × 3.90mm
	WSON (8)	4.00mm × 4.00mm

- (1) 利用可能なすべてのパッケージについては、このデータシートの末尾にある注文情報を参照してください。

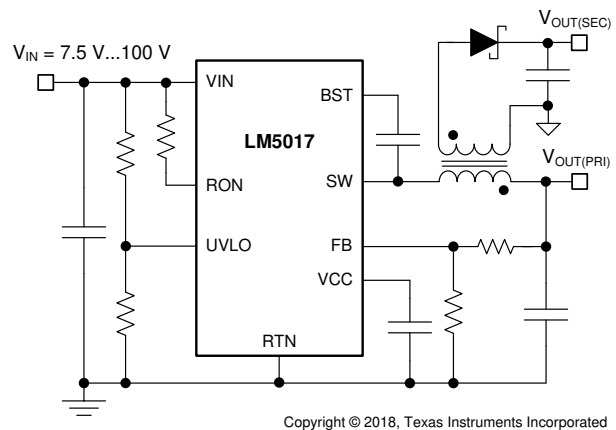

代表的な Fly-Buck アプリケーション回路



Table of Contents

1 特長	1	8 Application and Implementation	15
2 アプリケーション	1	8.1 Application Information.....	15
3 説明	1	8.2 Typical Application.....	15
4 Revision History	2	9 Power Supply Recommendations	25
5 Pin Configuration and Functions	3	10 Layout	26
6 Specifications	4	10.1 Layout Guidelines.....	26
6.1 Absolute Maximum Ratings.....	4	10.2 Layout Example.....	26
6.2 ESD Ratings.....	4	11 Device and Documentation Support	27
6.3 Recommended Operating Conditions.....	4	11.1 Device Support.....	27
6.4 Thermal Information.....	4	11.2 Documentation Support.....	27
6.5 Electrical Characteristics.....	5	11.3 Receiving Notification of Documentation Updates..	28
6.6 Timing Requirements.....	5	11.4 サポート・リソース.....	28
6.7 Typical Characteristics.....	7	11.5 Trademarks.....	28
7 Detailed Description	9	11.6 Electrostatic Discharge Caution.....	28
7.1 Overview.....	9	11.7 Glossary.....	28
7.2 Functional Block Diagram.....	9	12 Mechanical, Packaging, and Orderable Information	29
7.3 Feature Description.....	10		
7.4 Device Functional Modes.....	14		

4 Revision History

資料番号末尾の英字は改訂を表しています。その改訂履歴は英語版に準じています。

Changes from Revision J (November 2017) to Revision K (August 2021)	Page
• タイトルに「同期 Fly-Buck」を追加.....	1
• 文書全体にわたって表、図、相互参照の採番方法を更新.....	1
• 「アプリケーション」の箇条書きを更新、ハイパーリンクを追加.....	1
• Changed <i>Overview</i>	9
• Changed <i>Functional Block Diagram</i>	9
• Changed <i>Power Supply Recommendations</i>	25
• Updated <i>Related Documentation</i>	27

Changes from Revision I (October 2015) to Revision J (November 2017)	Page
• Deleted the lead temperature from the <i>Absolute Maximum Ratings</i> table.....	4

5 Pin Configuration and Functions



图 5-1. DDA Package 8-Pin SO PowerPAD Top View



图 5-2. NGU Package 8-Pin WSON With Exposed Thermal Pad Top View

表 5-1. Pin Functions

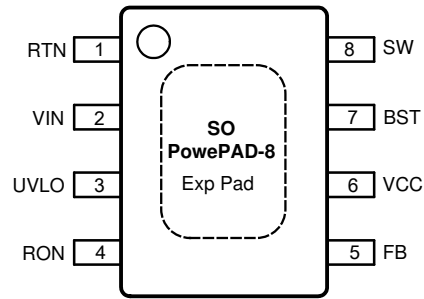
PIN		I/O	DESCRIPTION	APPLICATION INFORMATION
NO.	NAME			
1	RTN	—	Ground	Ground connection of the integrated circuit.
2	VIN	P	Input voltage	Operating input range is 7.5 V to 100 V.
3	UVLO	I	Undervoltage comparator input	Resistor divider from VIN to UVLO to GND programs the undervoltage detection threshold. An internal current source is enabled when UVLO is above 1.225 V to provide hysteresis. When UVLO pin is pulled below 0.66 V externally, the regulator is in shutdown mode.
4	RON	I	On-time control	A resistor between this pin and VIN sets the buck switch on-time as a function of VIN. Minimum recommended on-time is 100 ns at maximum input voltage.
5	FB	I	Feedback	This pin is connected to the inverting input of the internal regulation comparator. The regulation level is 1.225 V.
6	VCC	O	Output from the internal high-voltage series pass regulator. Regulated at 7.6 V.	The internal VCC regulator provides bias supply for the gate drivers and other internal circuitry. A 1-μF decoupling capacitor is recommended.
7	BST	I	Bootstrap capacitor	An external capacitor is required between the BST and SW pins (0.01-μF ceramic). The BST capacitor is charged by the VCC regulator through an internal diode when SW is low.
8	SW	P	Switching node	Power switching node. Connect to the output inductor and bootstrap capacitor.
	EP	—	Exposed Pad	Exposed pad must be connected to the RTN pin. Solder to the system ground plane on application board for reduced thermal resistance.

6 Specifications

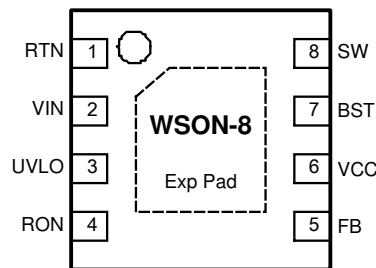
6.1 Absolute Maximum Ratings

See (1)

	MIN	MAX	UNIT
VIN, UVLO to RTN	-0.3	100	V
SW to RTN	-1.5	V _{IN} + 0.3	V
SW to RTN (100-ns transient)	-5	V _{IN} + 0.3	V
BST to VCC		100	V
BST to SW		13	V
RON to RTN	-0.3	100	V
VCC to RTN	-0.3	13	V
FB to RTN	-0.3	5	V
Maximum Junction Temperature ⁽²⁾		150	°C
Storage temperature, T _{stg}	-55	150	°C

- (1) *Absolute Maximum Ratings* are limits beyond which damage to the device may occur. [セクション 6.3](#) are conditions under which operation of the device is intended to be functional. For ensured specifications and test conditions, see the [セクション 6.5](#). The RTN pin is the GND reference electrically connected to the substrate.
- (2) High junction temperatures degrade operating lifetimes. Operating lifetime is de-rated for junction temperatures greater than 125°C.

6.2 ESD Ratings

		VALUE	UNIT
V _(ESD) Electrostatic discharge	Human-body model (HBM), per ANSI/ESDA/JEDEC JS-001 ⁽¹⁾	±2000	V
	Charged-device model (CDM), per JEDEC specification JESD22-C101 ⁽²⁾	±750	

- (1) JEDEC document JEP155 states that 500-V HBM allows safe manufacturing with a standard ESD control process.
- (2) JEDEC document JEP157 states that 250-V CDM allows safe manufacturing with a standard ESD control process.

6.3 Recommended Operating Conditions

Over operating free-air temperature range (unless otherwise noted)⁽¹⁾

	MIN	MAX	UNIT
V _{IN} Voltage ⁽¹⁾	7.5	100	V
Operating Junction Temperature ⁽²⁾	-40	125	°C

- (1) *Recommended Operating Conditions* are conditions under the device is intended to be functional. For specifications and test conditions, see [セクション 6.5](#).
- (2) High junction temperatures degrade operating lifetimes. Operating lifetime is de-rated for junction temperatures greater than 125°C.

6.4 Thermal Information

THERMAL METRIC ⁽¹⁾	LM5017		UNIT
	NGU (WSO)	DDA (SO PowerPAD™)	
	8 PINS	8 PINS	
R _{θJA} Junction-to-ambient thermal resistance	41.3	41.1	°C/W
R _{θJCb} Junction-to-case (bottom) thermal resistance	3.2	2.4	°C/W
Ψ _{JB} Junction-to-board thermal characteristic parameter	19.2	24.4	°C/W
R _{θJB} Junction-to-board thermal resistance	19.1	30.6	°C/W
R _{θJCTop} Junction-to-case (top) thermal resistance	34.7	37.3	°C/W
Ψ _{JT} Junction-to-top thermal characteristic parameter	0.3	6.7	°C/W

- (1) For more information about traditional and new thermal metrics, see the [Semiconductor and IC Package Thermal Metrics application report](#).

6.5 Electrical Characteristics

Typical values correspond to $T_J = 25^\circ\text{C}$. Minimum and maximum limits apply over -40°C to 125°C junction temperature range, unless otherwise stated. $V_{IN} = 48\text{ V}$, unless otherwise stated. See⁽¹⁾

PARAMETER		TEST CONDITIONS	MIN	TYP	MAX	UNIT
V_{CC} SUPPLY						
V _{CC}	VCC regulator output	$V_{IN} = 48\text{ V}$, $I_{CC} = 20\text{ mA}$	6.25	7.6	8.55	V
I _{LIM-VCC}	VCC current limit	$V_{IN} = 48\text{ V}$ ⁽²⁾	26			mA
V _{CC-UV}	VCC undervoltage lockout voltage (V_{VCC} increasing)	$-40^\circ\text{C} \leq T_J \leq 125^\circ\text{C}$	4.15	4.5	4.9	V
V _{CC-UV-HYS}	VCC undervoltage hysteresis			300		mV
V _{CC-LDO}	V _{IN} – VCC dropout voltage	$V_{IN} = 9\text{ V}$, $I_{CC} = 20\text{ mA}$		2.3		V
I _{OP}	I _{IN} operating current	Non-switching, $V_{FB} = 3\text{ V}$		1.75		mA
I _{SHD}	I _{IN} shutdown current	$V_{UVLO} = 0\text{ V}$		50	225	μA
SWITCH CHARACTERISTICS						
R _{DS(ON)1}	Buck switch R _{DS(on)}	$I_{TEST} = 200\text{ mA}$, $V_{BST} - V_{SW} = 7\text{ V}$		0.8	1.8	Ω
R _{DS(ON)2}	Synchronous switch R _{DS(on)}	$I_{TEST} = 200\text{ mA}$		0.45	1	Ω
BST _{UV}	Gate drive UVLO	$V_{BST} - V_{SW}$ rising	2.4	3	3.6	V
BST _{UV-HYS}	Gate drive UVLO hysteresis			260		mV
CURRENT LIMIT						
I _{LIM-HS}	Current limit threshold	$-40^\circ\text{C} \leq T_J \leq 125^\circ\text{C}$	0.7	1.02	1.3	A
t _{RES}	Current limit response time	Time to switch off		150		ns
t _{OFF1}	OFF-time generator (test 1)	$V_{FB} = 0.1\text{ V}$, $V_{IN} = 48\text{ V}$		12		μs
t _{OFF2}	OFF-time generator (test 2)	$V_{FB} = 1\text{ V}$, $V_{IN} = 48\text{ V}$		2.5		μs
REGULATION AND OVERVOLTAGE COMPARATORS						
V _{FB}	FB regulation level	Internal reference trip point for switch ON	1.2	1.225	1.25	V
V _{FB-OV}	FB overvoltage threshold	Trip point for switch OFF		1.62		V
I _{FB-BIAS}	FB bias current			60		nA
UNDERVOLTAGE SENSING FUNCTION						
V _{UVLO-TH}	UVLO threshold	Voltage at UVLO rising	1.19	1.225	1.26	V
I _{UVLO-HYS}	UVLO hysteresis input current	$V_{UVLO} = 2.5\text{ V}$	-10	-20	-29	μA
V _{SD-TH}	Remote shutdown threshold	Voltage at UVLO falling	0.32	0.66		V
V _{SD-HYS}	Remote shutdown hysteresis			110		mV
THERMAL SHUTDOWN						
T _{SD}	Thermal shutdown temperature			165		°C
T _{SD-HYS}	Thermal shutdown hysteresis			20		°C

- (1) All hot and cold limits are specified by correlating the electrical characteristics to process and temperature variations and applying statistical process control.
- (2) VCC provides self bias for the internal gate drive and control circuits. Device thermal limitations limit external loading.

6.6 Timing Requirements

Typical values correspond to $T_J = 25^\circ\text{C}$. Minimum and maximum limits apply over -40°C to 125°C junction temperature range unless otherwise stated. $V_{IN} = 48\text{ V}$ unless otherwise stated.

			MIN	NOM	MAX	UNIT
ON-TIME GENERATOR						
t _{ON1}	t _{ON} test 1	$V_{IN} = 32\text{ V}$, $R_{ON} = 100\text{ k}\Omega$	270	350	460	ns
t _{ON2}	t _{ON} test 2	$V_{IN} = 48\text{ V}$, $R_{ON} = 100\text{ k}\Omega$	188	250	336	ns
t _{ON3}	t _{ON} test 3	$V_{IN} = 75\text{ V}$, $R_{ON} = 250\text{ k}\Omega$	250	370	500	ns
t _{ON4}	t _{ON} test 4	$V_{IN} = 10\text{ V}$, $R_{ON} = 250\text{ k}\Omega$	1880	3200	4425	ns

LM5017

JAJSBG6K – JANUARY 2012 – REVISED AUGUST 2021

Typical values correspond to $T_J = 25^\circ\text{C}$. Minimum and maximum limits apply over -40°C to 125°C junction temperature range unless otherwise stated. $V_{IN} = 48\text{ V}$ unless otherwise stated.

			MIN	NOM	MAX	UNIT
MINIMUM OFF-TIME						
$t_{\text{OFF}(\text{min})}$	Minimum off-timer	$V_{\text{FB}} = 0\text{ V}$		144		ns

6.7 Typical Characteristics

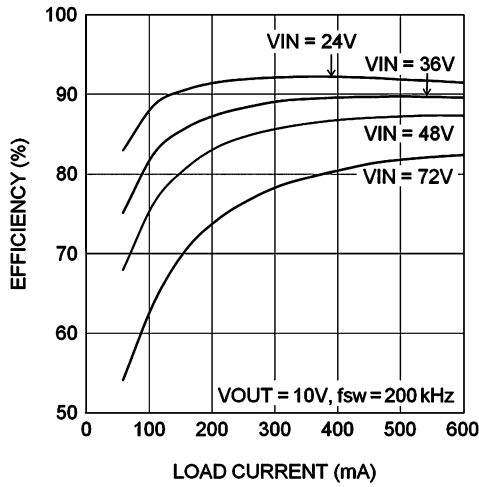

6-1. Efficiency at 200 kHz, 10 V

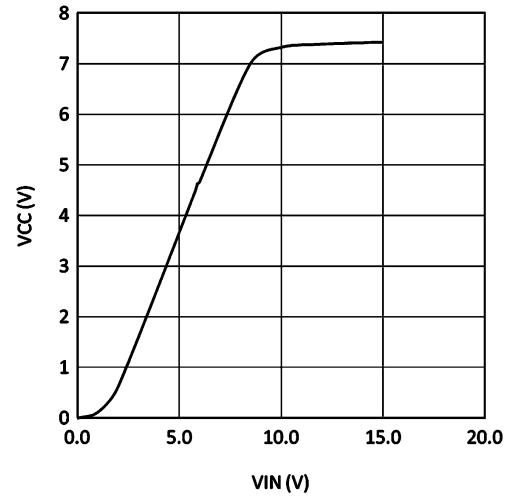

6-2. V_{CC} vs V_{IN}

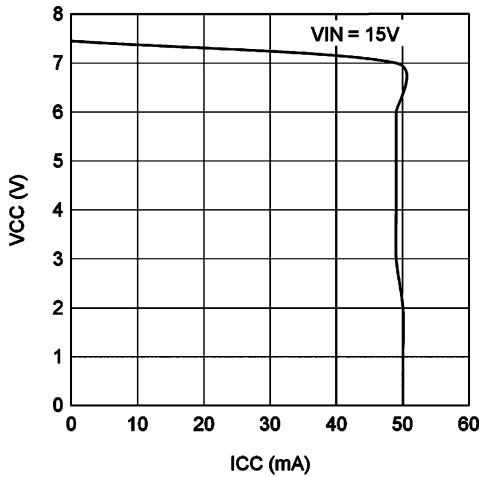

6-3. V_{CC} vs I_{CC}

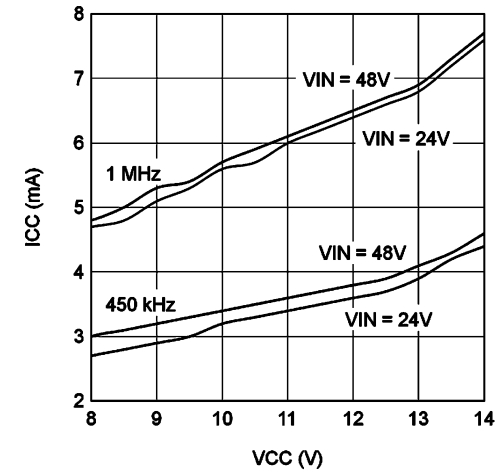

6-4. I_{CC} vs External V_{CC}

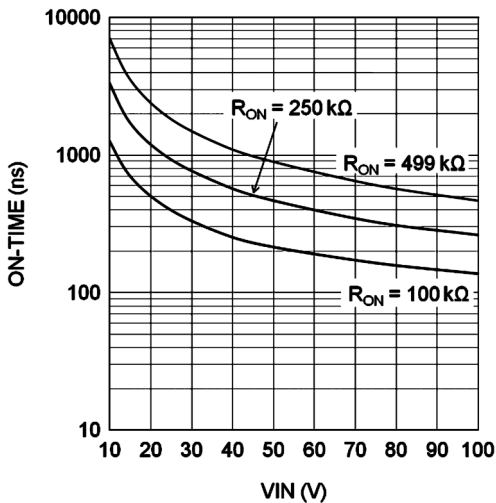

6-5. T_{ON} vs V_{IN} and R_{ON}

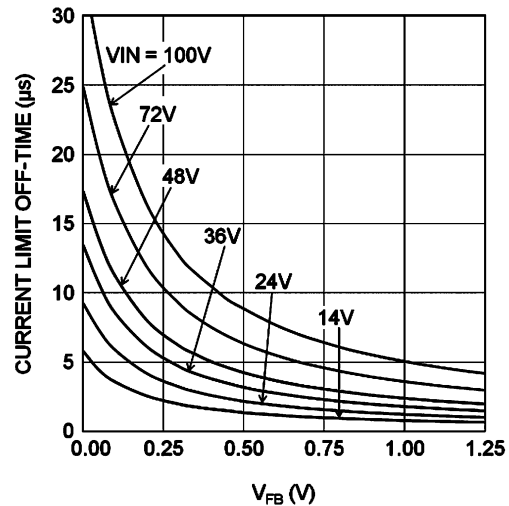

6-6. T_{OFF} (I_{LIM}) vs V_{FB} and V_{IN}

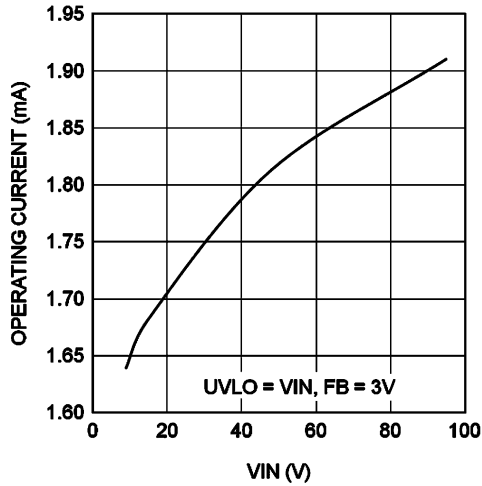

6-7. I_{IN} vs V_{IN} (Operating, Non-Switching)

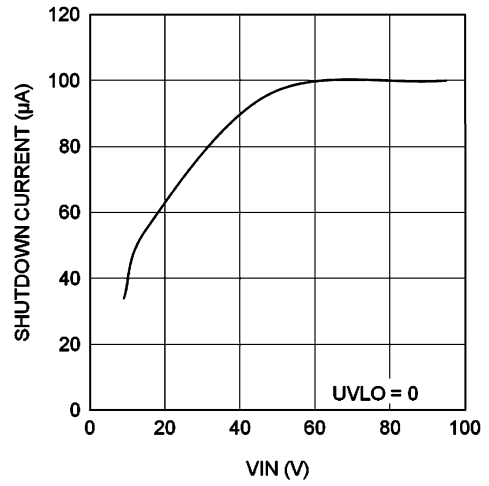

6-8. I_{IN} vs V_{IN} (Shutdown)

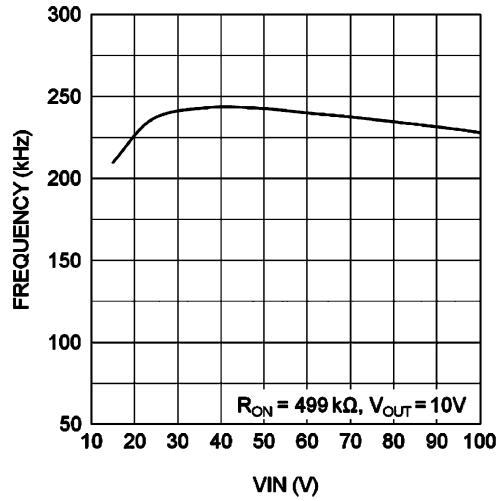

6-9. Switching Frequency vs V_{IN}

7 Detailed Description

7.1 Overview

The LM5017 step-down synchronous switching converter features all the functions needed to implement a low-cost, efficient buck regulator capable of supplying 600 mA to the load. This high-voltage regulator contains 100-V N-channel buck and synchronous rectifier switches and is available in 8-pin thermally-enhanced WSON and SO packages with pin pitches of 0.8 mm and 1.27 mm, respectively. The regulator operation is based on an adaptive constant on-time control architecture where the on-time is inversely proportional to input voltage V_{IN} . This feature maintains a relatively constant operating frequency with load and input voltage variations. A constant on-time switching regulator requires no loop compensation resulting in fast load transient response.

The LM5017 can be applied in numerous end equipment systems requiring efficient step-down regulation from higher input voltages. This regulator is well-suited for 24-V industrial systems as well as 48-V communications and PoE voltage ranges. The LM5017 integrates an undervoltage lockout (UVLO) circuit to prevent faulty operation of the device at low input voltages and features intelligent current limit and thermal shutdown to protect the device during overload or short circuit. Peak current limit detection circuit is implemented with a forced off-time during current limiting that is inversely proportional to V_{OUT} and directly proportional to V_{IN} . Varying the current limit off-time with V_{OUT} and V_{IN} ensures short-circuit protection with minimal current limit foldback. Additional protection features include thermal shutdown with automatic recovery, VCC and gate drive UVLO, minimum forced off-time, and remote shutdown.

7.2 Functional Block Diagram

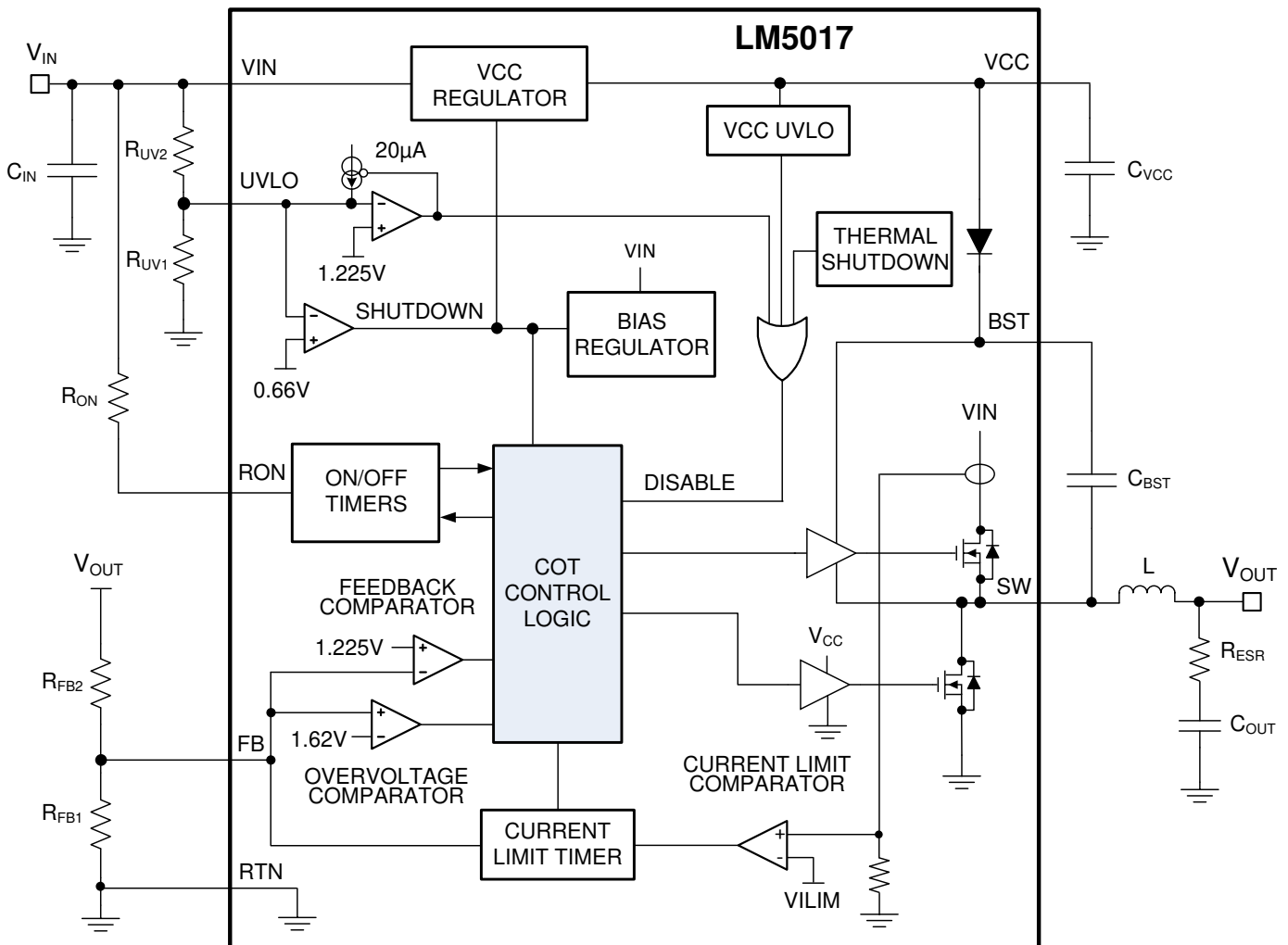

7.3 Feature Description

7.3.1 Control Overview

The LM5017 buck regulator employs a control principle based on a comparator and a one-shot on-timer, with the output voltage feedback (FB) compared to an internal reference (1.225 V). If the FB voltage is below the reference the internal buck switch is turned on for the one-shot timer period, which is a function of the input voltage and the programming resistor (R_{ON}). Following the on-time the switch remains off until the FB voltage falls below the reference, but never before the minimum off-time forced by the minimum off-time one-shot timer. When the FB pin voltage falls below the reference and the minimum off-time one-shot period expires, the buck switch is turned on for another on-time one-shot period. This will continue until regulation is achieved and the FB voltage is approximately equal to 1.225 V (typ).

In a synchronous buck converter, the low-side (sync) FET is on when the high-side (buck) FET is off. The inductor current ramps up when the high-side switch is on and ramps down when the high-side switch is 'off'. There is no diode emulation feature in this IC, and therefore, the inductor current may ramp in the negative direction at light load. This causes the converter to operate in continuous conduction mode (CCM) regardless of the output loading. The operating frequency remains relatively constant with load and line variations. Calculate the operating frequency as shown in 式 1.

$$f_{sw} = \frac{V_{OUT}}{K \times R_{ON}} \quad (1)$$

where

- $K = 9 \times 10^{-11}$

The output voltage (V_{OUT}) is set by two external resistors (R_{FB1} , R_{FB2}). The regulated output voltage is calculated as shown in 式 2.

$$V_{OUT} = 1.225V \times \frac{R_{FB2} + R_{FB1}}{R_{FB1}} \quad (2)$$

This regulator regulates the output voltage based on ripple voltage at the feedback input, requiring a minimum amount of ESR for the output capacitor (C_{OUT}). A minimum of 25 mV of ripple voltage at the feedback pin (FB) is required for the LM5017. In cases where the capacitor ESR is too small, additional series resistance may be required (R_C in 图 7-1).

For applications where lower output voltage ripple is required the output can be taken directly from a low ESR output capacitor, as shown in 图 7-1. However, R_C slightly degrades the load regulation.



图 7-1. Low Ripple Output Configuration

7.3.2 V_{CC} Regulator

The LM5017 device contains an internal high-voltage linear regulator with a nominal output of 7.6 V. The input pin (V_{IN}) can be connected directly to the line voltages up to 100 V. The V_{CC} regulator is internally current limited to 30 mA. The regulator sources current into the external capacitor at V_{CC} . This regulator supplies current to internal circuit blocks including the synchronous MOSFET driver and the logic circuits. When the voltage on the V_{CC} pin reaches the undervoltage lockout (V_{CC} UVLO) threshold of 4.5 V, the IC is enabled.

An internal diode connected from V_{CC} to the BST pin replenishes the charge in the gate drive bootstrap capacitor when SW pin is low.

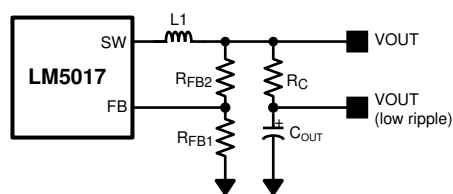
At high input voltages, the power dissipated in the high voltage regulator is significant and can limit the overall achievable output power. As an example, with the input at 48 V and switching at high frequency, the V_{CC} regulator may supply up to 7 mA of current resulting in $48\text{ V} \times 7\text{ mA} = 336\text{ mW}$ of power dissipation. If the V_{CC} voltage is driven externally by an alternate voltage source between 8.55 V and 13 V, the internal regulator is disabled. This reduces the power dissipation in the IC.

7.3.3 Regulation Comparator

The feedback voltage at FB is compared to an internal 1.225 V reference. In normal operation, when the output voltage is in regulation, an on-time period is initiated when the voltage at FB falls below 1.225 V. The high side switch will stay on for the on-time, causing the FB voltage to rise above 1.225 V. After the on-time period, the high side switch will stay off until the FB voltage again falls below 1.225 V. During start-up, the FB voltage will be below 1.225 V at the end of each on-time, causing the high side switch to turn on immediately after the minimum forced off-time of 144 ns. The high side switch can be turned off before the on-time is over if the peak current in the inductor reaches the current limit threshold.

7.3.4 Overvoltage Comparator

The feedback voltage at FB is compared to an internal 1.62 V reference. If the voltage at FB rises above 1.62 V the on-time pulse is immediately terminated. This condition can occur if the input voltage and/or the output load changes suddenly. The high side switch will not turn on again until the voltage at FB falls below 1.225 V.

7.3.5 On-Time Generator

The on-time for the LM5017 device is determined by the R_{ON} resistor and is inversely proportional to the input voltage (V_{IN}), resulting in a nearly constant frequency as V_{IN} is varied over the operating range. The on-time for the LM5017 can be calculated using 式 3.

$$T_{ON} = \frac{10^{-10} \times R_{ON}}{V_{IN}} \quad (3)$$

See 图 6-5. R_{ON} should be selected for a minimum on-time (at maximum V_{IN}) greater than 100 ns for proper operation. This requirement limits the maximum switching frequency for high V_{IN} .

7.3.6 Current Limit

The LM5017 device contains an intelligent current limit off-timer. If the current in the buck switch exceeds 1.02 A, the present cycle is immediately terminated, and a non-resetable off-timer is initiated. The length of the off-time is controlled by the FB voltage and the input voltage V_{IN} . As an example, when $FB = 0\text{ V}$ and $V_{IN} = 48\text{ V}$, the off-time is set to 16 μs . This condition occurs when the output is shorted and during the initial part of start-up. This V_{IN} dependent off-time ensures safe short circuit operation up to the maximum input voltage of 100 V.

In cases of overload where the FB voltage is above zero volts (not a short circuit) the current limit off-time is reduced. Reducing the off-time during less severe overloads reduces the amount of foldback, recovery time, and start-up time. The off-time is calculated from 式 4.

$$T_{OFF(ILIM)} = \frac{0.07 \times V_{IN}}{V_{FB} + 0.2\text{ V}} \mu\text{s} \quad (4)$$

The current limit protection feature is peak limited. The maximum average output current will be less than the peak.

7.3.7 N-Channel Buck Switch and Driver

The LM5017 device integrates an N-Channel Buck switch and associated floating high voltage gate driver. The gate driver circuit works in conjunction with an external bootstrap capacitor and an internal high voltage diode. A 0.01 μF ceramic capacitor connected between the BST pin and the SW pin provides the voltage to the driver during the on-time. During each off-time, the SW pin is at approximately 0 V, and the bootstrap capacitor charges from V_{CC} through the internal diode. The minimum off-timer, set to 144 ns, ensures a minimum time each cycle to recharge the bootstrap capacitor.

7.3.8 Synchronous Rectifier

The LM5017 provides an internal synchronous N-Channel MOSFET rectifier. This MOSFET provides a path for the inductor current to flow when the high-side MOSFET is turned off.

The synchronous rectifier has no diode emulation mode, and is designed to keep the regulator in continuous conduction mode even with light loads which would otherwise result in discontinuous operation.

7.3.9 Undervoltage Detector

The LM5017 device contains a dual level undervoltage lockout (UVLO) circuit. A summary of threshold voltages and operational states is provided in [セクション 7.4](#). When the UVLO pin voltage is below 0.66 V, the regulator is in a low current shutdown mode. When the UVLO pin voltage is greater than 0.66V but less than 1.225 V, the regulator is in standby mode. In standby mode the V_{CC} bias regulator is active while the regulator output is disabled. When the V_{CC} pin exceeds the V_{CC} undervoltage threshold and the UVLO pin voltage is greater than 1.225 V, normal operation begins. An external set-point voltage divider from V_{IN} to GND can be used to set the minimum operating voltage of the regulator.

UVLO hysteresis is accomplished with an internal 20- μ A current source that is switched on or off into the impedance of the set-point divider. When the UVLO threshold is exceeded, the current source is activated to quickly raise the voltage at the UVLO pin. The hysteresis is equal to the value of this current times the resistance R_{UV2} .

If the UVLO pin is connected directly to the V_{IN} pin, the regulator will begin operation once the V_{CC} undervoltage is satisfied.



图 7-2. UVLO Resistor Setting

7.3.10 Thermal Protection

The LM5017 device should be operated so the junction temperature does not exceed 150°C during normal operation. An internal Thermal Shutdown circuit is provided to protect the LM5017 in the event of a higher than normal junction temperature. When activated, typically at 165°C, the regulator is forced into a low power reset state, disabling the buck switch and the V_{CC} regulator. This feature prevents catastrophic failures from accidental device overheating. When the junction temperature falls below 145°C (typical hysteresis = 20°C), the V_{CC} regulator is enabled, and normal operation is resumed.

7.3.11 Ripple Configuration

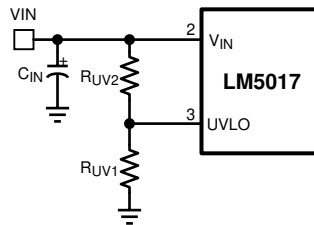
LM5017 uses Constant-On-Time (COT) control in which the on-time is terminated by an on-timer and the off-time is terminated by the feedback voltage (V_{FB}) falling below the reference voltage (V_{REF}). Therefore, for stable operation, the feedback voltage must decrease monotonically, in phase with the inductor current during the off-time. Furthermore, this change in feedback voltage (V_{FB}) during off-time must be larger than any noise component present at the feedback node.

表 7-1 shows three different methods for generating appropriate voltage ripple at the feedback node. Type 1 and Type 2 ripple circuits couple the ripple at the output of the converter to the feedback node (FB). The output voltage ripple has two components:

1. Capacitive ripple caused by the inductor current ripple charging/discharging the output capacitor.
2. Resistive ripple caused by the inductor current ripple flowing through the ESR of the output capacitor.

The capacitive ripple is not in phase with the inductor current. As a result, the capacitive ripple does not decrease monotonically during the off-time. The resistive ripple is in phase with the inductor current and

decreases monotonically during the off-time. The resistive ripple must exceed the capacitive ripple at the output node (V_{OUT}) for stable operation. If this condition is not satisfied unstable switching behavior is observed in COT converters, with multiple on-time bursts in close succession followed by a long off-time.

Type 3 ripple method uses R_r and C_r and the switch node (SW) voltage to generate a triangular ramp. This triangular ramp is ac coupled using C_{ac} to the feedback node (FB). Since this circuit does not use the output voltage ripple, it is ideally suited for applications where low output voltage ripple is required. For more information on each ripple generation method, refer to the [AN-1481 Controlling Output Ripple and Achieving ESR Independence in Constant On-Time \(COT\) Regulator Designs](#) application report.

表 7-1. Ripple Configuration

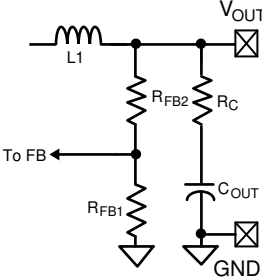
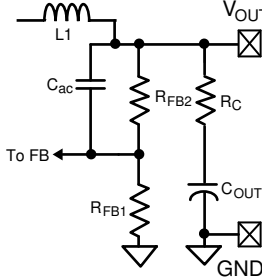
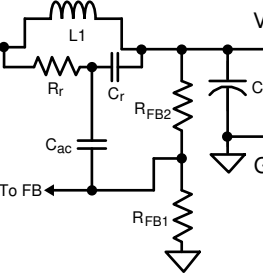
TYPE 1 LOWEST COST CONFIGURATION	TYPE 2 REDUCED RIPPLE CONFIGURATION	TYPE 3 MINIMUM RIPPLE CONFIGURATION
		
$R_C \geq \frac{25 \text{ mV}}{\Delta I_{L(\text{MIN})}} \times \frac{V_{OUT}}{V_{REF}} \quad (5)$	$C \geq \frac{5}{f_{sw} (R_{FB2} R_{FB1})}$ $R_C \geq \frac{25 \text{ mV}}{\Delta I_{L(\text{MIN})}} \quad (6)$	$R_r C_r \leq \frac{(V_{IN(\text{MIN})} - V_{OUT}) \times T_{ON}}{25 \text{ mV}} \quad (7)$ <p style="text-align: center;"> $C_r = 3300 \text{ pF}$ $C_{ac} = 100 \text{ nF}$ </p>

7.3.12 Soft-Start

A soft-start feature can be implemented with the LM5017 using an external circuit. As shown in [Figure 7-3](#), the soft-start circuit consists of one capacitor, C_1 , two resistors, R_1 and R_2 , and a diode, D . During the initial start-up, the VCC voltage is established prior to the V_{OUT} voltage. Capacitor C_1 is discharged and D is thereby forward biased to pull up the FB voltage. The FB voltage exceeds the reference voltage (1.225 V) and switching is therefore disabled. As capacitor C_1 charges, the voltage at node B gradually decreases and switching commences. V_{OUT} will gradually rise to maintain the FB voltage at the reference voltage. Once the voltage at node B is less than a diode drop above FB voltage, the soft-start is finished and D is reverse biased.

During the initial part of the start-up, the FB voltage can be approximated as follows. Please note that the effect of R_1 has been ignored to simplify the calculation shown in [Equation 8](#).

$$V_{FB} = (V_{CC} - V_D) \times \frac{R_{FB1} \times R_{FB2}}{R_2 \times (R_{FB1} + R_{FB2}) + R_{FB1} \times R_{FB2}} \quad (8)$$

C_1 is charged after the first start up. Diode D_1 is optional and can be added to discharge C_1 when the input voltage experiences a momentary drop to initialize the soft-start sequence.

To achieve the desired soft-start, the following design guidance is recommended:

(1) R_2 is selected so that V_{FB} is higher than 1.225 V for a V_{CC} of 4.5 V, but is lower than 5 V when V_{CC} is 8.55 V. If an external V_{CC} is used, V_{FB} should not exceed 5 V at maximum V_{CC} .

(2) C_1 is selected to achieve the desired start-up time that can be determined from 式 9.

$$t_S = C_1 \times \left(R_2 + \frac{R_{FB1} \times R_{FB2}}{R_{FB1} + R_{FB2}} \right) \quad (9)$$

(3) R_1 is used to maintain the node B voltage at zero after the soft-start is finished. A value larger than the feedback resistor divider is preferred. Note that the effect of R_1 is ignored in the previous equations.

Based on the schematic shown in 图 8-1, selecting $C_1 = 1 \mu\text{F}$, $R_2 = 1 \text{ k}\Omega$, $R_1 = 30 \text{ k}\Omega$ results in a soft-start time of about 2 ms.



图 7-3. Soft-Start Circuit

7.4 Device Functional Modes

表 7-2. UVLO Modes

UVLO	V_{CC} Regulator	MODE	DESCRIPTION
< 0.66 V	Disabled	Shutdown	V_{CC} regulator disabled. Switching disabled.
0.66 V – 1.225 V	Enabled	Standby	V_{CC} regulator enabled. Switching disabled.
> 1.225 V	$V_{CC} < 4.5 \text{ V}$	Standby	V_{CC} regulator enabled. Switching disabled.
	$V_{CC} > 4.5 \text{ V}$	Operating	V_{CC} enabled. Switching enabled.

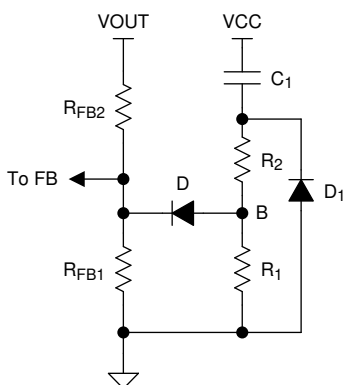
8 Application and Implementation

Note

Information in the following applications sections is not part of the TI component specification, and TI does not warrant its accuracy or completeness. TI's customers are responsible for determining suitability of components for their purposes, as well as validating and testing their design implementation to confirm system functionality.

8.1 Application Information

The LM5017 device is step-down DC-DC converter. The device is typically used to convert a higher DC voltage to a lower DC voltage with a maximum available output current of 650 mA. Use the following design procedure to select component values for the LM5017 device. Alternately, use the WEBENCH® software to generate a complete design. The WEBENCH software uses an iterative design procedure and accesses a comprehensive database of components when generating a design. This section presents a simplified discussion of the design process.

8.2 Typical Application

8.2.1 Application Circuit: 12.5-V to 95-V Input and 10-V, 600-mA Output Buck Converter

The application schematic of a buck supply is shown in [Figure 8-1](#). For output voltage (V_{OUT}) more than one diode drop above the maximum regulation threshold of V_{CC} (8.55 V, see [Section 6.5](#)), the V_{CC} pin can be connected to V_{OUT} through a diode (D2), as shown in [Figure 8-1](#), for higher efficiency and lower power dissipation in the IC.

The design example below uses equations from the [Section 7.3](#) with component names provided. Corresponding component designators from [Figure 8-1](#) are also provided for each selected value.

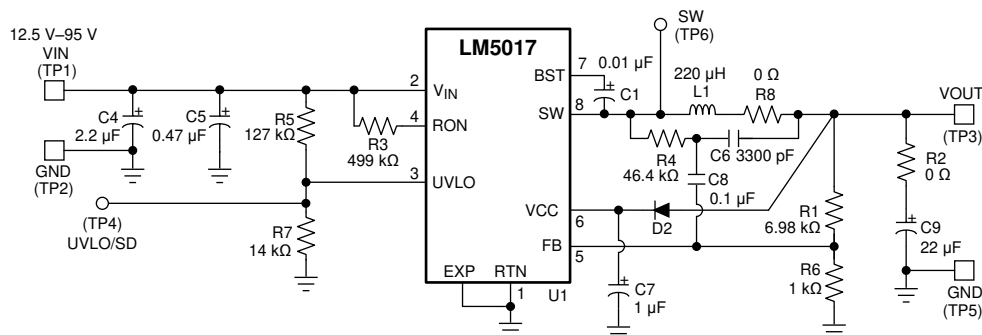

Figure 8-1. Final Schematic for 12.5-V to 95-V Input, and 10-V, 600-mA Output Buck Converter

8.2.1.1 Design Requirements

Selection of external components is illustrated through a design example. The design example specifications are shown in [Table 8-1](#).

Table 8-1. Buck Converter Design Specifications

DESIGN PARAMETERS	VALUE
Input voltage range	12.5 V to 95 V
Output voltage	10 V
Maximum Load current	600 mA
Switching Frequency	≈ 225 kHz

8.2.1.2 Detailed Design Procedure

8.2.1.2.1 Custom Design with WEBENCH Tools

[Click here](#) to create a custom design using the WEBENCH® Power Designer.

1. Start by entering your V_{IN} , V_{OUT} and I_{OUT} requirements.
2. Optimize your design for key parameters like efficiency, footprint and cost using the optimizer dial and compare this design with other possible solutions from Texas Instruments.
3. WEBENCH Power Designer provides you with a customized schematic along with a list of materials with real time pricing and component availability.
4. In most cases, you will also be able to:
 - Run electrical simulations to see important waveforms and circuit performance,
 - Run thermal simulations to understand the thermal performance of your board,
 - Export your customized schematic and layout into popular CAD formats,
 - Print PDF reports for the design, and share your design with colleagues.

8.2.1.2.2 R_{FB1} , R_{FB2}

$V_{OUT} = V_{FB} \times (R_{FB2}/R_{FB1} + 1)$, and because $V_{FB} = 1.225$ V, the ratio of R_{FB2} to R_{FB1} calculates as 7 : 1. Standard values are chosen with $R_{FB2} = R1 = 6.98$ k Ω and $R_{FB1} = R6 = 1$ k Ω . Other values could be used as long as the 7 : 1 ratio is maintained.

8.2.1.2.3 Frequency Selection

At the minimum input voltage, the maximum switching frequency of LM5017 is restricted by the forced minimum off-time ($T_{OFF(MIN)}$) as given by 式 10.

$$f_{SW(MAX)} = \frac{1 - D_{MAX}}{T_{OFF(MIN)}} = \frac{1 - 10/12.5}{200 \text{ ns}} = 1 \text{ MHz} \quad (10)$$

Similarly, at maximum input voltage, the maximum switching frequency of LM5017 is restricted by the minimum T_{ON} as given by 式 11.

$$f_{SW(MAX)} = \frac{D_{MIN}}{T_{ON(MIN)}} = \frac{10/95}{100 \text{ ns}} = 1.05 \text{ MHz} \quad (11)$$

Resistor R_{ON} sets the nominal switching frequency based on 式 12.

$$f_{SW} = \frac{V_{OUT}}{K \times R_{ON}} \quad (12)$$

where

- $K = 9 \times 10^{-11}$

Operation at high switching frequency results in lower efficiency while providing the smallest solution. For this example a conservative 225 kHz was selected, resulting in $R_{ON} = 493$ k Ω . A standard value for $R_{ON} = R3 = 499$ k Ω is selected.

8.2.1.2.4 Inductor Selection

The minimum inductance is selected to limit the output ripple to 15 to 40 percent of the maximum load current. In addition, the peak inductor current at maximum load should be smaller than the minimum current limit as given in セクション 6.5 table.

The inductor current ripple is given by 式 13.

$$\Delta I_L = \frac{V_{IN} - V_{OUT}}{L1 \times f_{SW}} \times \frac{V_{OUT}}{V_{IN}} \quad (13)$$

The maximum ripple is observed at maximum input voltage. Substituting $V_{IN} = 95$ V and $\Delta I_L = 40$ percent $\times I_{OUT(max)}$ results in $L1 = 198$ μ H. The next higher standard value of 220 μ H is chosen. The peak-to-peak minimum and maximum inductor current ripple are 40 mA and 181 mA at the minimum and maximum input voltages respectively. The peak inductor and switch current is given by 式 14.

$$I_{L1}(\text{peak}) = I_{OUT} + \frac{\Delta I_{L(\text{MAX})}}{2} = 690 \text{ mA} \quad (14)$$

690 mA is less than the minimum current limit threshold of 0.7 A. The selected inductor should be able to withstand the maximum current limit of 1.3 A during startup and overload conditions without saturating.

8.2.1.2.5 Output Capacitor

The output capacitor is selected to minimize the capacitive ripple across it. The maximum ripple is observed at maximum input voltage and is given by:

$$C_{OUT} = \frac{\Delta I_L}{8 \times f_{sw} \times \Delta V_{\text{ripple}}} \quad (15)$$

where

- ΔV_{ripple} is the voltage ripple across the capacitor.

Assuming $V_{IN} = 95 \text{ V}$ and substituting $\Delta V_{\text{ripple}} = 10 \text{ mV}$ gives $C_{OUT} = 10.1 \text{ }\mu\text{F}$. A 22- μF standard value is selected for $C_{OUT} = C9$. An X5R or X7R type capacitor with a voltage rating 16 V or higher should be selected.

8.2.1.2.6 Type III Ripple Circuit

Type III ripple circuit as described in [セクション 7.3.11](#) is chosen for this example. For a constant on-time converter to be stable, the injected in-phase ripple should be larger than the capacitive ripple on C_{OUT} .

Using the type III ripple circuit equation, the target ripple will be greater than the capacitive ripple generated at the primary-side output if the following condition is satisfied:

$$C_r = C6 = 3300 \text{ pF}$$

$$C_{ac} = C8 = 100 \text{ nF}$$

$$R_r \leq \frac{(V_{IN(\text{MIN})} - V_{OUT}) \times T_{ON(VINMIN)}}{(25 \text{ mV} \times C_r)} \quad (16)$$

For T_{ON} , refer to [式 3](#).

Ripple resistor R_r is calculated to be 57.6 k Ω . This value provides the minimum ripple for stable operation. A smaller resistance should be selected to allow for variations in T_{ON} , C_{OUT} , and other components. $R_r = R4 = 46.4 \text{ k}\Omega$ is selected for this example application.

8.2.1.2.7 V_{CC} and Bootstrap Capacitors

The V_{CC} capacitor provides charge to bootstrap capacitor as well as internal circuitry and low side gate driver. The Bootstrap capacitor provides charge to high side gate driver. The recommended value for $C_{VCC} = C7 = 1 \text{ }\mu\text{F}$. A good value for $C_{BST} = C1 = 0.01 \text{ }\mu\text{F}$.

8.2.1.2.8 Input Capacitor

Input capacitor should be large enough to limit the input voltage ripple as shown in [式 17](#).

$$C_{IN} \geq \frac{I_{OUT(\text{MAX})}}{4 \times f_{sw} \times \Delta V_{IN}} \quad (17)$$

Choosing a $\Delta V_{IN} = 0.5 \text{ V}$ gives a minimum $C_{IN} = 1.3 \text{ }\mu\text{F}$. A standard value of 2.2 μF is selected for $C_{IN} = C4$. The input capacitor should be rated for the maximum input voltage under all conditions. A 100-V, X7R dielectric should be selected for this design.

The input capacitor should be placed directly across V_{IN} and RTN (pin 1 and 2) of the IC. If it is not possible to place all of the input capacitor close to the IC, a 0.47- μF capacitor should be placed near the IC to provide a bypass path for the high frequency component of the switching current.

8.2.1.2.9 UVLO Resistors

The UVLO resistors R_{FB1} and R_{FB2} set the UVLO threshold and hysteresis according to the relationship shown in 式 18 and 式 19.

$$V_{IN}(HYS) = I_{HYS} \times R_{UV2} \quad (18)$$

where

- $I_{HYS} = 20 \mu A$

$$V_{IN}(UVLO, rising) = 1.225 V \times \left(\frac{R_{UV2}}{R_{UV1}} + 1 \right) \quad (19)$$

Setting UVLO hysteresis of 2.5 V and UVLO rising threshold of 12 V results in $R_{UV1} = 14.53 \text{ k}\Omega$ and $R_{UV2} = 125 \text{ k}\Omega$. Selecting standard values of $R_{UV1} = R7 = 14 \text{ k}\Omega$ and $R_{UV2} = R5 = 127 \text{ k}\Omega$ results in UVLO threshold and hysteresis of 12.4 V and 2.5 V respectively.

8.2.1.3 Application Curves

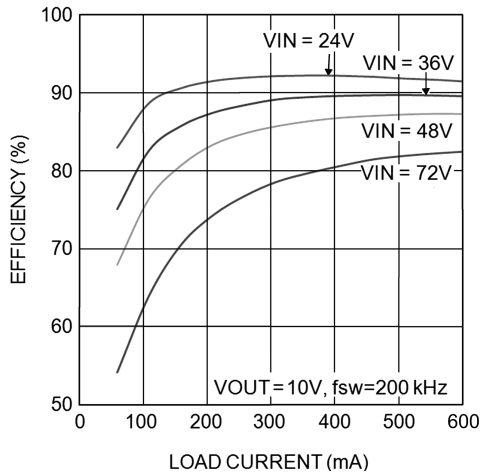

8-2. Efficiency vs Load Current

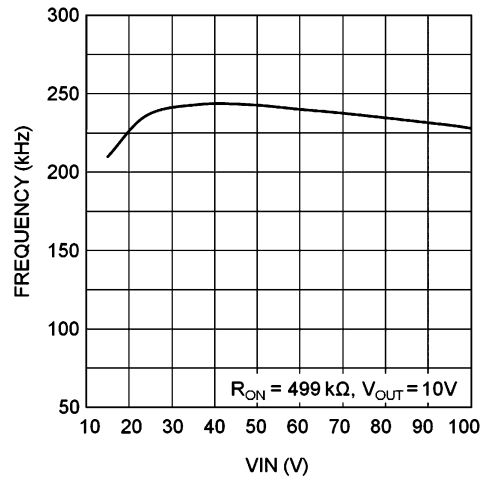

8-3. Frequency vs Input Voltage

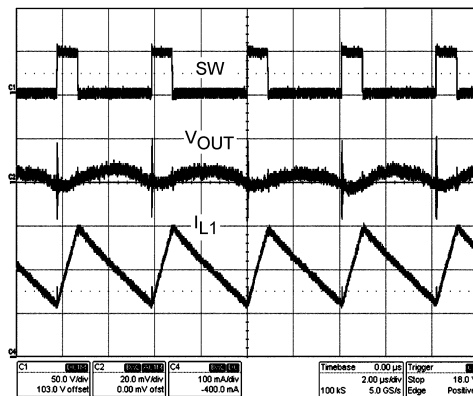

8-4. Typical Switching Waveform ($V_{IN} = 48\text{ V}$, $I_{OUT} = 200\text{ mA}$)

8.2.2 Isolated DC/DC Converter Using LM5017

An isolated supply using the LM5017 is shown in 8-5. Inductor (L) in a typical buck circuit is replaced with a coupled inductor (X1). A diode (D1) is used to rectify the voltage on a secondary output. The nominal voltage at the secondary output (V_{OUT2}) is given by 式 20.

$$V_{OUT2} = V_{OUT1} \times \frac{N_S}{N_P} - V_F \quad (20)$$

where

- V_F is the forward voltage drop of D1
- N_P and N_S are the number of turns on the primary and secondary of coupled inductor X1.

For output voltage (V_{OUT1}) more than one diode drop above the maximum V_{CC} (8.55 V), the V_{CC} pin can be diode connected to V_{OUT1} for higher efficiency and low dissipation in the IC. For a complete isolated bias design with LM5017, refer to the [AN-2204 LM5017 Isolated Supply Evaluation Board application report](#).



图 8-5. Typical Isolated Application Schematic

8.2.2.1 Design Requirements

DESIGN PARAMETERS	VALUE
Input Voltage Range	20 V – 100 V
Primary Output Voltage	10 V
Secondary (Isolated) Output Voltage	9.5 V
Maximum Load Current (Primary + Secondary)	300 mA
Maximum Power Output	3 W
Nominal Switching Frequency	750 kHz

8.2.2.2 Detailed Design Procedure

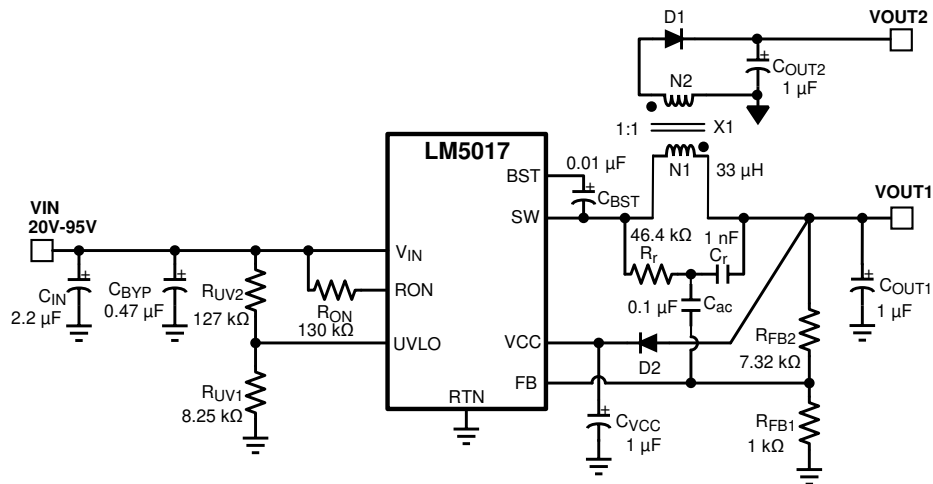
8.2.2.2.1 Transformer Turns Ratio

The transformer turns ratio is selected based on the ratio of the primary output voltage to the secondary (isolated) output voltage. In this design example, the two outputs are nearly equal and a 1 : 1 turns ratio transformer is selected. Therefore, $N2 / N1 = 1$.

If the secondary (isolated) output voltage is significantly higher or lower than the primary output voltage, a turns ratio less than or greater than 1 is recommended. The primary output voltage is normally selected based on the input voltage range such that the duty cycle of the converter does not exceed 50% at the minimum input voltage. This condition is satisfied if $V_{OUT1} < V_{IN_MIN} / 2$.

8.2.2.2.2 Total I_{OUT}

Calculate the total primary-referred load current by multiplying the isolated output loads by the turns ratio of the transformer as shown in 式 21.

$$I_{OUT(MAX)} = I_{OUT1} + I_{OUT2} \times \frac{N2}{N1} = 0.3 \text{ A} \quad (21)$$

8.2.2.2.3 R_{FB1} , R_{FB2}

The feedback resistors are selected to set the primary output voltage. The selected value for R_{FB1} is 1 kΩ. R_{FB2} can be calculated using the following equations to set V_{OUT1} to the specified value of 10 V. A standard resistor value of 7.32 kΩ is selected for R_{FB2} .

$$V_{OUT1} = 1.225 \text{ V} \times \left(1 + \frac{R_{FB2}}{R_{FB1}} \right) \quad (22)$$

$$\rightarrow R_{FB2} = \left(\frac{V_{OUT1}}{1.225} - 1 \right) \times R_{FB1} = 7.16 \text{ k}\Omega \quad (23)$$

8.2.2.2.4 Frequency Selection

Calculate the value of R_{ON} to achieve the desired switching frequency using 式 24.

$$f_{SW} = \frac{V_{OUT1}}{K \times R_{ON}} \quad (24)$$

where

- $K = 9 \times 10^{-11}$

For V_{OUT1} of 10 V and f_{SW} of 750 kHz, the calculated value of R_{ON} is 148 k Ω . A lower value of 130 k Ω is selected for this design to allow for second-order effects at high switching frequency that are not included in 式 24.

8.2.2.2.5 Transformer Selection

A coupled inductor or a flyback-type transformer is required for this topology. Energy is transferred from primary to secondary when the low-side synchronous switch of the buck converter is conducting.

The maximum inductor primary ripple current that can be tolerated without exceeding the buck switch peak current limit threshold (0.7 A minimum) is given by 式 25.

$$\Delta I_{L1} = \left(0.7 - I_{OUT1} - I_{OUT2} \times \frac{N2}{N1} \right) \times 2 = 0.8 \text{ A} \quad (25)$$

Using the maximum peak-to-peak inductor ripple current ΔI_{L1} from 式 25, the minimum inductor value is given by 式 26.

$$L1 = \frac{V_{IN(MAX)} - V_{OUT}}{\Delta I_{L1} \times f_{SW}} \times \frac{V_{OUT}}{V_{IN(MAX)}} = 14.9 \mu\text{H} \quad (26)$$

A higher value of 33 μH is selected to insure the high-side switch current does not exceed the minimum peak current limit threshold. With this inductance, the inductor current ripple is $\Delta I_{L1} = 0.36 \text{ A}$ at the maximum V_{IN} .

8.2.2.2.6 Primary Output Capacitor

In a conventional buck converter the output ripple voltage is calculated as shown in 式 27.

$$\Delta V_{OUT} = \frac{\Delta I_{L1}}{8 \times f \times C_{OUT1}} \quad (27)$$

To limit the primary output ripple voltage ΔV_{OUT1} to approximately 50 mV, an output capacitor C_{OUT1} of 1.2 μF would be required for a conventional buck.

☒ 8-6 shows the primary winding current waveform (I_{L1}) of a Fly-Buck™ converter. The reflected secondary winding current adds to the primary winding current during the buck switch off-time. Because of this increased current, the output voltage ripple is not the same as in conventional buck converter. The output capacitor value calculated in 式 27 should be used as the starting point. Optimization of output capacitance over the entire line and load range must be done experimentally. If the majority of the load current is drawn from the secondary isolated output, a better approximation of the primary output voltage ripple is given by 式 28.

$$\Delta V_{OUT1} = \frac{\left(I_{OUT2} \times \frac{N2}{N1} \right) \times T_{ON(MAX)}}{C_{OUT1}} \approx 67 \text{ mV} \quad (28)$$



图 8-6. Current Waveforms for C_{OUT1} Ripple Calculation

A standard 1- μ F, 25 V capacitor is selected for this design. If lower output voltage ripple is required, a higher value should be selected for C_{OUT1} and/or C_{OUT2} .

8.2.2.2.7 Secondary Output Capacitor

A simplified waveform for secondary output current (I_{OUT2}) is shown in 图 8-7.

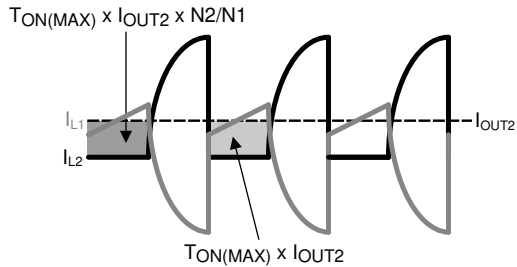

图 8-7. Secondary Current Waveforms for C_{OUT2} Ripple Calculation

The secondary output current (I_{OUT2}) is sourced by C_{OUT2} during on-time of the buck switch, T_{ON} . Ignoring the current transition times in the secondary winding, the secondary output capacitor ripple voltage can be calculated using 式 29.

$$\Delta V_{OUT2} = \frac{I_{OUT2} \times T_{ON(MAX)}}{C_{OUT2}} \quad (29)$$

For a 1 : 1 transformer turns ratio, the primary and secondary voltage ripple equations are identical. Therefore, C_{OUT2} is chosen to be equal to C_{OUT1} (1 μ F) to achieve comparable ripple voltages on primary and secondary outputs.

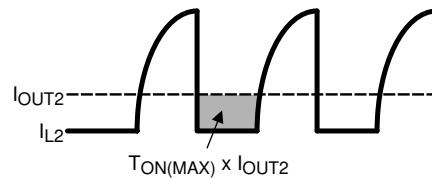
If lower output voltage ripple is required, a higher value should be selected for C_{OUT1} and/or C_{OUT2} .

8.2.2.2.8 Type III Feedback Ripple Circuit

Type III ripple circuit as described in セクション 7.3.11 is required for the Fly-Buck topology. Type I and Type II ripple circuits use series resistance and the triangular inductor ripple current to generate ripple at V_{OUT} and the FB pin. The primary ripple current of a Fly-Buck is the combination of primary and reflected secondary currents as illustrated in 图 8-6. In the Fly-Buck topology, Type I and Type II ripple circuits suffer from large jitter as the reflected load current affects the feedback ripple.



图 8-8. Type III Ripple Circuit

Selecting the Type III ripple components using the equations from [セクション 7.3.11](#) will ensure that the FB pin ripple is be greater than the capacitive ripple from the primary output capacitor C_{OUT1}. The feedback ripple component values are chosen as shown in [式 30](#).

$$\begin{aligned} C_r &= 1000 \text{ pF} \\ C_{ac} &= 0.1 \text{ } \mu\text{F} \\ R_f C_r &\leq \frac{(V_{IN(MIN)} - V_{OUT}) \times T_{ON}}{50 \text{ mV}} \end{aligned} \tag{30}$$

The calculated value for R_f is 66 kΩ. This value provides the minimum ripple for stable operation. A smaller resistance should be selected to allow for variations in T_{ON}, C_{OUT1} and other components. For this design, R_f value of 46.4 kΩ is selected.

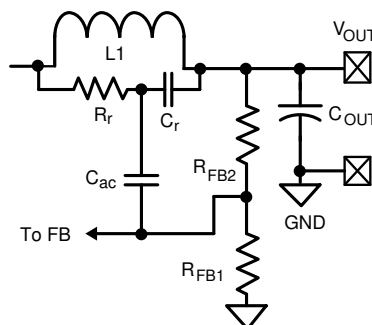
8.2.2.2.9 Secondary Diode

The reverse voltage across secondary-rectifier diode D1 when the high-side buck switch is off can be calculated using [式 31](#).

$$V_{D1} = \frac{N2}{N1} V_{IN} \tag{31}$$

For a V_{IN_MAX} of 95 V and the 1:1 turns ratio of this design, a 100 V Schottky is selected.

8.2.2.2.10 V_{CC} and Bootstrap Capacitor

A 1-μF capacitor of 16 V or higher rating is recommended for the V_{CC} regulator bypass capacitor. A good value for the BST pin bootstrap capacitor is 0.01-μF with a 16 V or higher rating.

8.2.2.2.11 Input Capacitor

The input capacitor is typically a combination of a smaller bypass capacitor located near the regulator IC and a larger bulk capacitor. The total input capacitance should be large enough to limit the input voltage ripple to a desired amplitude. For input ripple voltage ΔV_{IN}, C_{IN} can be calculated using [式 32](#).

$$C_{IN} \geq \frac{I_{OUT(MAX)}}{4 \times f \times \Delta V_{IN}} \tag{32}$$

Choosing a ΔV_{IN} of 0.5 V gives a minimum C_{IN} of 0.2 μF. A standard value of 0.47 μF is selected for C_{BYP} in this design. A bulk capacitor of higher value reduces voltage spikes due to parasitic inductance between the power source to the converter. A standard value of 2.2 μF is selected for C_{IN} in this design. The voltage ratings of the two input capacitors should be greater than the maximum input voltage under all conditions.

8.2.2.2.12 UVLO Resistors

UVLO resistors R_{UV1} and R_{UV2} set the undervoltage lockout threshold and hysteresis according to [式 33](#) and [式 34](#).

$$V_{IN(HYS)} = I_{HYS} \times R_{UV2} \tag{33}$$

where

- I_{HYS} = 20 μA, typical.

$$V_{IN(UVLO, \text{ rising})} = 1.225V \times \left(\frac{R_{UV2}}{R_{UV1}} + 1 \right) \tag{34}$$

For a UVLO hysteresis of 2.5 V and UVLO rising threshold of 20 V, [式 33](#) and [式 34](#) require R_{UV1} of 8.25 kΩ and R_{UV2} of 127 kΩ and these values are selected for this design example.

LM5017

JAJSBG6K – JANUARY 2012 – REVISED AUGUST 2021

8.2.2.2.13 V_{CC} Diode

Diode D2 is an optional diode connected between V_{OUT1} and the V_{CC} regulator output pin. When V_{OUT1} is more than one diode drop greater than the V_{CC} voltage, the V_{CC} bias current is supplied from V_{OUT1}. This results in reduced power losses in the internal V_{CC} regulator which improves converter efficiency. V_{OUT1} must be set to a voltage at least one diode drop higher than 8.55 V (the maximum V_{CC} voltage) if D2 is used to supply bias current.

8.2.2.3 Application Curves

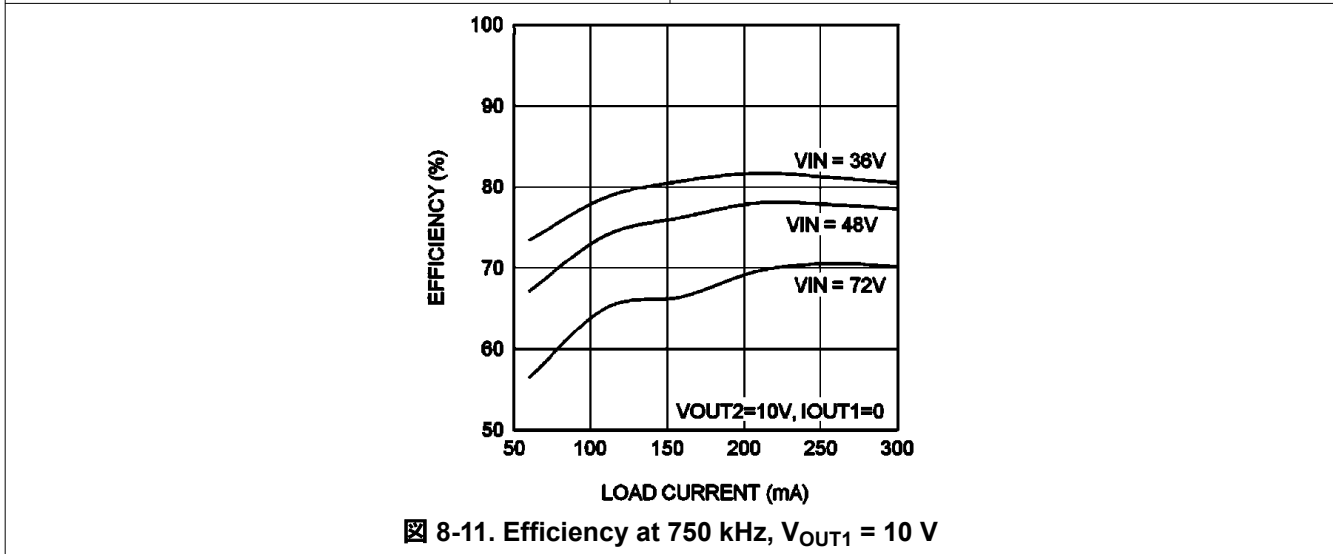
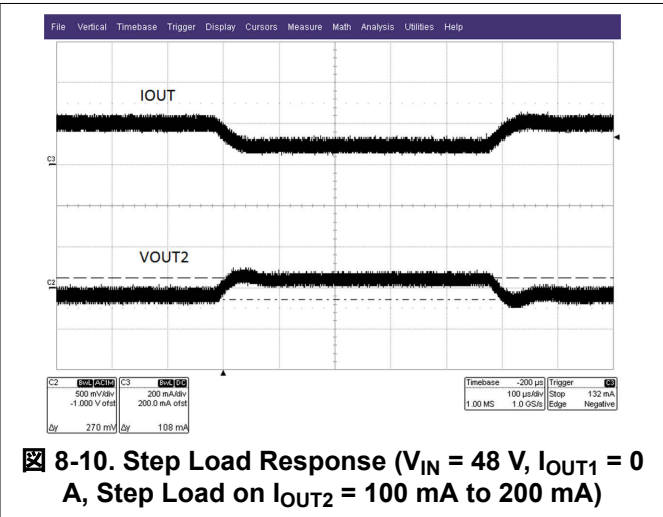
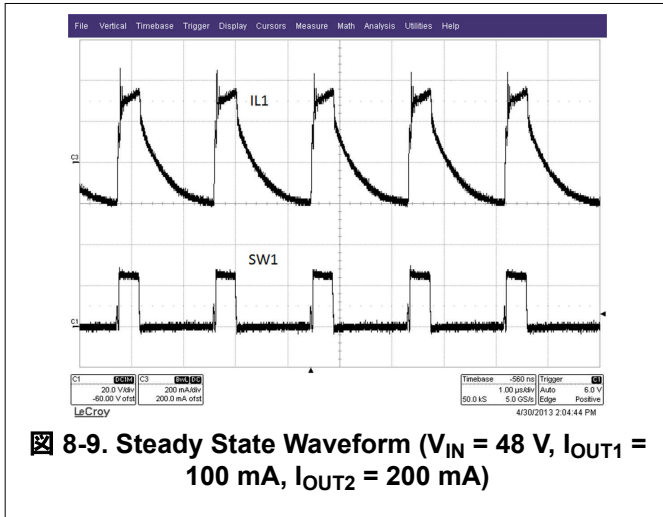

9 Power Supply Recommendations

The LM5017 DC/DC converter is designed to operate from a wide input voltage range of 7.5 V to 100 V. The characteristics of the input supply must be compatible with the [セクション 6.1](#) and [セクション 6.3](#) tables. In addition, the input supply must be capable of delivering the required input current to the fully-loaded regulator. Estimate the average input current with [式 35](#).

$$I_{IN} = \frac{P_{OUT}}{V_{IN} \cdot \eta} \quad (35)$$

where

- η is the efficiency

If the regulator is connected to an input supply through long wires or PCB traces with a large impedance, take special care to achieve stable performance. The parasitic inductance and resistance of the input cables may have an adverse affect on converter operation, particularly during operation at low input voltage. The parasitic inductance in combination with the low-ESR ceramic input capacitors form an underdamped resonant circuit. This circuit can cause overvoltage transients at V_{IN} each time the input supply is cycled on and off. The parasitic resistance causes the input voltage to dip during a load transient. The best way to solve such issues is to reduce the distance from the input supply to the regulator and use an aluminum or tantalum input capacitor in parallel with the ceramics. The moderate ESR of the electrolytic capacitors helps to damp the input resonant circuit and reduce any voltage overshoots. A capacitance in the range of 4.7 μF to 22 μF is usually sufficient to provide input parallel damping and helps to hold the input voltage steady during large load transients.

An EMI input filter is often used in front of the regulator that, unless carefully designed, can lead to instability as well as some of the effects mentioned above. The application report [Simple Success with Conducted EMI for DC-DC Converters](#) (SNVA489) provides helpful suggestions when designing an input filter for any switching regulator.

10 Layout

10.1 Layout Guidelines

A proper layout is essential for optimum performance of the circuit. In particular, the following guidelines should be observed:

1. C_{IN} : The loop consisting of input capacitor (C_{IN}), V_{IN} pin, and RTN pin carries switching currents. Therefore, the input capacitor should be placed close to the IC, directly across V_{IN} and RTN pins and the connections to these two pins should be direct to minimize the loop area. In general it is not possible to accommodate all of input capacitance near the IC. A good practice is to use a 0.1- μ F or 0.47- μ F capacitor directly across the V_{IN} and RTN pins close to the IC, and the remaining bulk capacitor as close as possible (see [Figure 10-1](#)).
2. C_{VCC} and C_{BST} : The V_{CC} and bootstrap (BST) bypass capacitors supply switching currents to the high and low side gate drivers. These two capacitors should also be placed as close to the IC as possible, and the connecting trace length and loop area should be minimized (see [Figure 10-1](#)).
3. The Feedback trace carries the output voltage information and a small ripple component that is necessary for proper operation of LM5017. Therefore, care should be taken while routing the feedback trace to avoid coupling any noise to this pin. In particular, feedback trace should not run close to magnetic components, or parallel to any other switching trace.
4. SW trace: The SW node switches rapidly between V_{IN} and GND every cycle and is therefore a possible source of noise. The SW node area should be minimized. In particular, the SW node should not be inadvertently connected to a copper plane or pour.

10.2 Layout Example

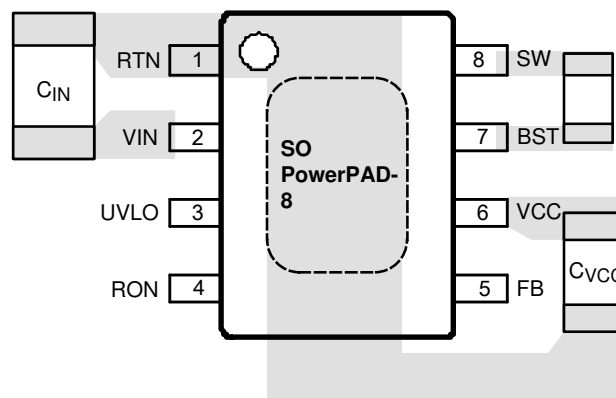

Figure 10-1. Placement of Bypass Capacitors

11 Device and Documentation Support

11.1 Device Support

11.1.1 Third-Party Products Disclaimer

TI'S PUBLICATION OF INFORMATION REGARDING THIRD-PARTY PRODUCTS OR SERVICES DOES NOT CONSTITUTE AN ENDORSEMENT REGARDING THE SUITABILITY OF SUCH PRODUCTS OR SERVICES OR A WARRANTY, REPRESENTATION OR ENDORSEMENT OF SUCH PRODUCTS OR SERVICES, EITHER ALONE OR IN COMBINATION WITH ANY TI PRODUCT OR SERVICE.

11.1.2 Development Support

For development support, see the following:

- [LM5017 Buck Converter Quick-start Calculator](#)
- [Fly-Buck Converter Quick-start Calculator](#)
- [LM5017 PSPICE Transient Model](#)
- [LM5017 TINA-TI Transient Spice Model](#)
- [LM5017 TINA-TI Transient Reference Design](#)
- For TI's reference design library, visit [TI Reference Designs](#)
- For TI's WEBENCH Design Environment, visit the [WEBENCH® Design Center](#).
- To view a related device of this product, see the [LM5018](#) 100-V, 300-mA synchronous buck converter.
- Power House Blogs:
 - [Fly-Buck: Frequently Asked Questions \(FAQs\)](#)
 - [Lower EMI and Quiet Switching With the Fly-Buck Topology](#)
 - [Fly-Buck Converter PCB Layout Tips](#)
 - [When is Fly-Buck the Right Choice for Your Isolated Power Needs?](#)
 - [How to Design for EMC and Isolation With Fly-Buck Converters](#)
 - [Create a Fly-Buck Converter in WEBENCH® Power Designer](#)

11.1.2.1 Custom Design With WEBENCH® Tools

[Click here](#) to create a custom design using the LM5017 device with the WEBENCH® Power Designer.

1. Start by entering the input voltage (V_{IN}), output voltage (V_{OUT}), and output current (I_{OUT}) requirements.
2. Optimize the design for key parameters such as efficiency, footprint, and cost using the optimizer dial.
3. Compare the generated design with other possible solutions from Texas Instruments.

The WEBENCH Power Designer provides a customized schematic along with a list of materials with real-time pricing and component availability.

In most cases, these actions are available:

- Run electrical simulations to see important waveforms and circuit performance
- Run thermal simulations to understand board thermal performance
- Export customized schematic and layout into popular CAD formats
- Print PDF reports for the design, and share the design with colleagues

Get more information about WEBENCH tools at www.ti.com/WEBENCH.

11.2 Documentation Support

11.2.1 Related Documentation

For related documentation, see the following:

- [AN-2200 LM5017 Evaluation Board](#) (SNVA612)
- [AN-2204 LM5017 Isolated Supply Evaluation Board](#) (SNVA611)
- [AN-2292 Designing an Isolated Buck \(Fly-Buck\) Converter](#) (SNVA674)
- [AN-1481 Controlling Output Ripple & Achieving ESR Independence in Constant ON-Time Regulator Designs](#) (SNVA166)
- TI Reference Designs:
 - [Dual Channel-to-Channel Isolated Universal Analog Input Module for PLC Reference Design](#) (TIDUBI1)

- [High Voltage Stepper Driver Reference Design \(TIDUCR6\)](#)
- [Reference Design for Voltage, Current & Temp Monitoring for Solar Module Level Power Electronics \(TIDUCM3\)](#)
- [High Resolution, Fast Startup Analog Front End for Air Circuit Breaker Reference Design \(TIDUB80\)](#)
- [Signal Processing Front End for Electronic Trip Units Used in ACBs/MCCBs reference design \(TIDUA09\)](#)
- [Ultra-Small 1W, 12V-36V Iso Power Supply for Analog Prog Logic Controller Modules Reference Design \(TIDU855\)](#)
- [16-Bit Analog Output Module Reference Design for Programmable Logic Controllers \(PLCs\) \(TIDU189\)](#)
- [2.5W Bipolar Isolated Fly-Buck Ultra-Compact Reference Design \(TIDUCA3\)](#)
- [Class 3 Isolated Fly-Buck Power Module for PoE Application Reference Design \(TIDU779\)](#)
- [Wide-Input Isolated IGBT Gate-Drive Fly-Buck Power Supply for Three-Phase Inverters \(TIDU670\)](#)
- [Isolated RS-485 to Wi-Fi Bridge with 24 VAC Power Reference Design \(TIDUA49\)](#)
- [Dual-Output Isolated Fly-Buck Reference Design With an Ultra-Small Coupled Inductor \(TIDUC31\)](#)
- [Small Footprint Isolated DC/DC Converter for Analog Input Module Reference Design \(TIDUBR7\)](#)
- [Leakage Current Measurement Reference Design for Determining Insulation Resistance \(TIDU873\)](#)
- [Thermal Protection Reference Design of IGBT Modules for HEV/EV Traction Inverters \(TIDUBJ2\)](#)
- White Papers:
 - [Designing Isolated Rails on the Fly With Fly-Buck Converters](#)
 - [Valuing Wide \$V_{IN}\$, Low-EMI Synchronous Buck Circuits for Cost-Effective, Demanding Applications](#)
 - [An Overview of Conducted EMI Specifications for Power Supplies](#)
 - [An Overview of Radiated EMI Specifications for Power Supplies](#)
- [AN-2162: Simple Success with Conducted EMI from DC-DC Converters \(SNVA489\)](#)
- [Using New Thermal Metrics \(SBVA025\)](#)
- [Semiconductor and IC Package Thermal Metrics \(SPRA953\)](#)

11.3 Receiving Notification of Documentation Updates

To receive notification of documentation updates, navigate to the device product folder on ti.com. Click on [Subscribe to updates](#) to register and receive a weekly digest of any product information that has changed. For change details, review the revision history included in any revised document.

11.4 サポート・リソース

TI E2E™ サポート・フォーラムは、エンジニアが検証済みの回答と設計に関するヒントをエキスパートから迅速かつ直接得ることができる場所です。既存の回答を検索したり、独自の質問をしたりすることで、設計に必要な支援を迅速に得ることができます。

リンクされているコンテンツは、該当する貢献者により、現状のまま提供されるものです。これらは TI の仕様を構成するものではなく、必ずしも TI の見解を反映したものではありません。TI の [使用条件](#) を参照してください。

11.5 Trademarks

PowerPAD™ and are trademarks of Texas Instruments.

Fly-Buck™ and TI E2E™ are trademarks of Texas Instruments.

WEBENCH® are registered trademarks of Texas Instruments.

すべての商標は、それぞれの所有者に帰属します。

11.6 Electrostatic Discharge Caution



This integrated circuit can be damaged by ESD. Texas Instruments recommends that all integrated circuits be handled with appropriate precautions. Failure to observe proper handling and installation procedures can cause damage.

ESD damage can range from subtle performance degradation to complete device failure. Precision integrated circuits may be more susceptible to damage because very small parametric changes could cause the device not to meet its published specifications.

11.7 Glossary

[TI Glossary](#) This glossary lists and explains terms, acronyms, and definitions.

12 Mechanical, Packaging, and Orderable Information

The following pages include mechanical, packaging, and orderable information. This information is the most current data available for the designated devices. This data is subject to change without notice and revision of this document. For browser-based versions of this data sheet, refer to the left-hand navigation.

PACKAGING INFORMATION

Orderable Device	Status (1)	Package Type	Package Drawing	Pins	Package Qty	Eco Plan (2)	Lead finish/ Ball material (6)	MSL Peak Temp (3)	Op Temp (°C)	Device Marking (4/5)	Samples
LM5017MR/NOPB	ACTIVE	SO PowerPAD	DDA	8	95	RoHS & Green	NIPDAU SN	Level-3-260C-168 HR	-40 to 125	L5017 MR	Samples
LM5017MRE/NOPB	ACTIVE	SO PowerPAD	DDA	8	250	RoHS & Green	NIPDAU SN	Level-3-260C-168 HR	-40 to 125	L5017 MR	Samples
LM5017MRX/NOPB	ACTIVE	SO PowerPAD	DDA	8	2500	RoHS & Green	NIPDAU SN	Level-3-260C-168 HR	-40 to 125	L5017 MR	Samples
LM5017SD/NOPB	ACTIVE	WSON	NGU	8	1000	RoHS & Green	SN	Level-1-260C-UNLIM	-40 to 125	L5017	Samples
LM5017SDE/NOPB	ACTIVE	WSON	NGU	8	250	RoHS & Green	SN	Level-1-260C-UNLIM	-40 to 125	L5017	Samples
LM5017SDX/NOPB	ACTIVE	WSON	NGU	8	4500	RoHS & Green	SN	Level-1-260C-UNLIM	-40 to 125	L5017	Samples

(1) The marketing status values are defined as follows:

ACTIVE: Product device recommended for new designs.

LIFEBUY: TI has announced that the device will be discontinued, and a lifetime-buy period is in effect.

NRND: Not recommended for new designs. Device is in production to support existing customers, but TI does not recommend using this part in a new design.

PREVIEW: Device has been announced but is not in production. Samples may or may not be available.

OBSOLETE: TI has discontinued the production of the device.

(2) **RoHS:** TI defines "RoHS" to mean semiconductor products that are compliant with the current EU RoHS requirements for all 10 RoHS substances, including the requirement that RoHS substance do not exceed 0.1% by weight in homogeneous materials. Where designed to be soldered at high temperatures, "RoHS" products are suitable for use in specified lead-free processes. TI may reference these types of products as "Pb-Free".

RoHS Exempt: TI defines "RoHS Exempt" to mean products that contain lead but are compliant with EU RoHS pursuant to a specific EU RoHS exemption.

Green: TI defines "Green" to mean the content of Chlorine (Cl) and Bromine (Br) based flame retardants meet JS709B low halogen requirements of <=1000ppm threshold. Antimony trioxide based flame retardants must also meet the <=1000ppm threshold requirement.

(3) MSL, Peak Temp. - The Moisture Sensitivity Level rating according to the JEDEC industry standard classifications, and peak solder temperature.

(4) There may be additional marking, which relates to the logo, the lot trace code information, or the environmental category on the device.

(5) Multiple Device Markings will be inside parentheses. Only one Device Marking contained in parentheses and separated by a "~" will appear on a device. If a line is indented then it is a continuation of the previous line and the two combined represent the entire Device Marking for that device.

⁽⁶⁾ Lead finish/Ball material - Orderable Devices may have multiple material finish options. Finish options are separated by a vertical ruled line. Lead finish/Ball material values may wrap to two lines if the finish value exceeds the maximum column width.

Important Information and Disclaimer:The information provided on this page represents TI's knowledge and belief as of the date that it is provided. TI bases its knowledge and belief on information provided by third parties, and makes no representation or warranty as to the accuracy of such information. Efforts are underway to better integrate information from third parties. TI has taken and continues to take reasonable steps to provide representative and accurate information but may not have conducted destructive testing or chemical analysis on incoming materials and chemicals. TI and TI suppliers consider certain information to be proprietary, and thus CAS numbers and other limited information may not be available for release.

In no event shall TI's liability arising out of such information exceed the total purchase price of the TI part(s) at issue in this document sold by TI to Customer on an annual basis.

TAPE AND REEL INFORMATION

QUADRANT ASSIGNMENTS FOR PIN 1 ORIENTATION IN TAPE

*All dimensions are nominal

Device	Package Type	Package Drawing	Pins	SPQ	Reel Diameter (mm)	Reel Width W1 (mm)	A0 (mm)	B0 (mm)	K0 (mm)	P1 (mm)	W (mm)	Pin1 Quadrant
LM5017MRE/NOPB	SO PowerPAD	DDA	8	250	330.0	12.5	6.4	5.2	2.1	8.0	12.0	Q1
LM5017MRE/NOPB	SO PowerPAD	DDA	8	250	178.0	12.4	6.5	5.4	2.0	8.0	12.0	Q1
LM5017MRX/NOPB	SO PowerPAD	DDA	8	2500	330.0	12.5	6.4	5.2	2.1	8.0	12.0	Q1
LM5017MRX/NOPB	SO PowerPAD	DDA	8	2500	330.0	12.4	6.5	5.4	2.0	8.0	12.0	Q1
LM5017SD/NOPB	WSON	NGU	8	1000	178.0	12.4	4.3	4.3	1.3	8.0	12.0	Q1
LM5017SDX/NOPB	WSON	NGU	8	4500	330.0	12.4	4.3	4.3	1.3	8.0	12.0	Q1

TAPE AND REEL BOX DIMENSIONS

*All dimensions are nominal

Device	Package Type	Package Drawing	Pins	SPQ	Length (mm)	Width (mm)	Height (mm)
LM5017MRE/NOPB	SO PowerPAD	DDA	8	250	340.5	338.1	20.6
LM5017MRE/NOPB	SO PowerPAD	DDA	8	250	208.0	191.0	35.0
LM5017MRX/NOPB	SO PowerPAD	DDA	8	2500	340.5	338.1	20.6
LM5017MRX/NOPB	SO PowerPAD	DDA	8	2500	356.0	356.0	36.0
LM5017SD/NOPB	WSON	NGU	8	1000	208.0	191.0	35.0
LM5017SDX/NOPB	WSON	NGU	8	4500	367.0	367.0	35.0

TUBE

*All dimensions are nominal

Device	Package Name	Package Type	Pins	SPQ	L (mm)	W (mm)	T (μm)	B (mm)
LM5017MR/NOPB	DDA	HSOIC	8	95	495	8	4064	3.05
LM5017MR/NOPB	DDA	HSOIC	8	95	507.79	8	630	4.32

DDA0008B



PACKAGE OUTLINE

PowerPAD™ SOIC - 1.7 mm max height

PLASTIC SMALL OUTLINE

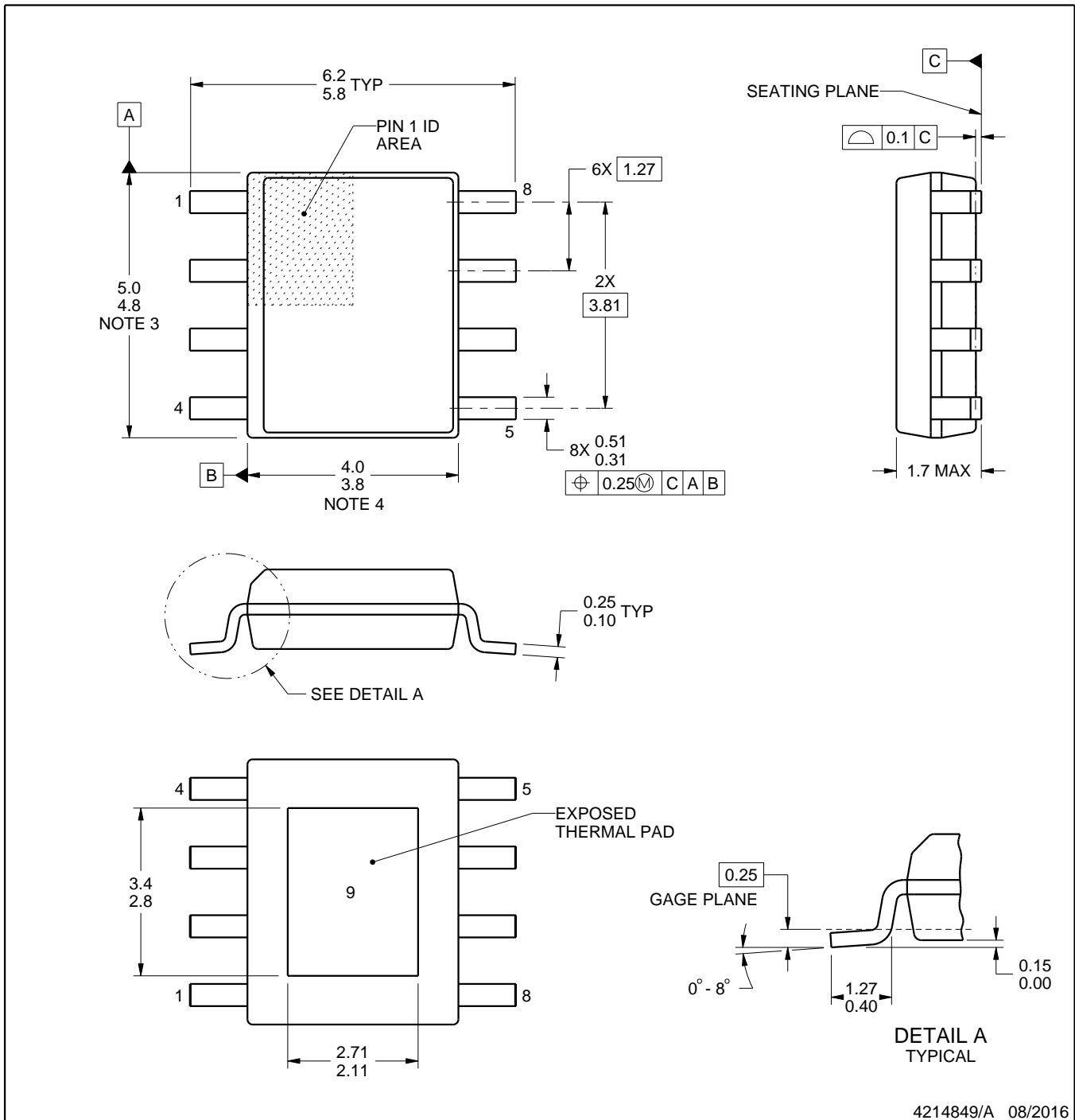

4214849/A 08/2016

PowerPAD is a trademark of Texas Instruments.

NOTES:

1. All linear dimensions are in millimeters. Any dimensions in parenthesis are for reference only. Dimensioning and tolerancing per ASME Y14.5M.
2. This drawing is subject to change without notice.
3. This dimension does not include mold flash, protrusions, or gate burrs. Mold flash, protrusions, or gate burrs shall not exceed 0.15 mm per side.
4. This dimension does not include interlead flash. Interlead flash shall not exceed 0.25 mm per side.
5. Reference JEDEC registration MS-012.

EXAMPLE BOARD LAYOUT

DDA0008B

PowerPAD™ SOIC - 1.7 mm max height

PLASTIC SMALL OUTLINE

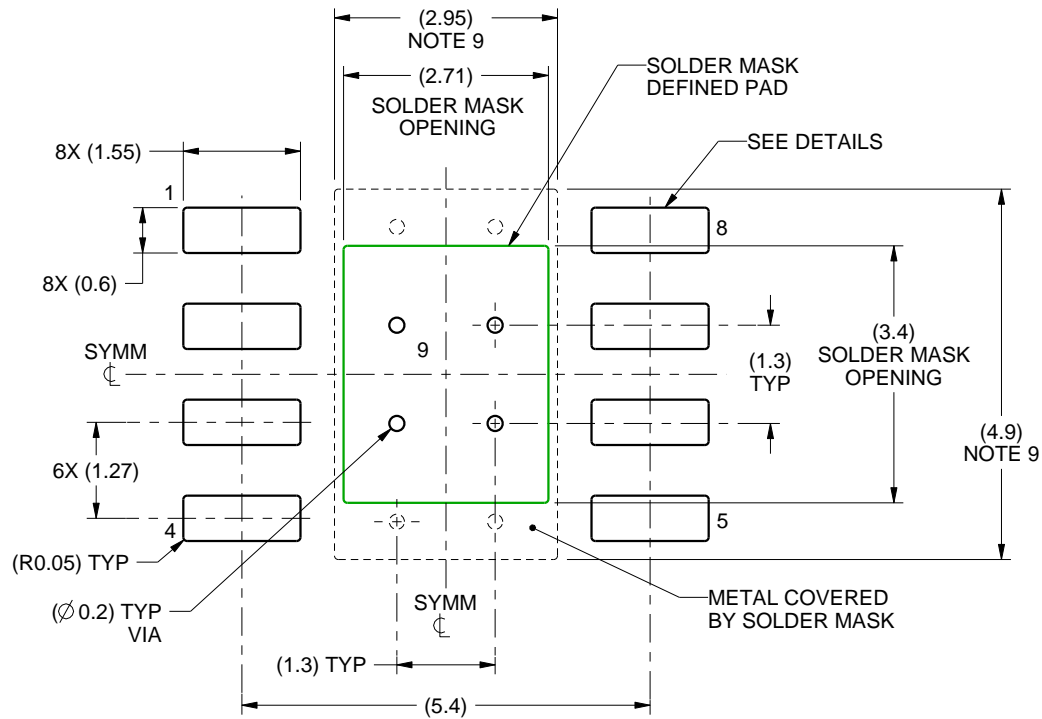

LAND PATTERN EXAMPLE
SCALE:10X

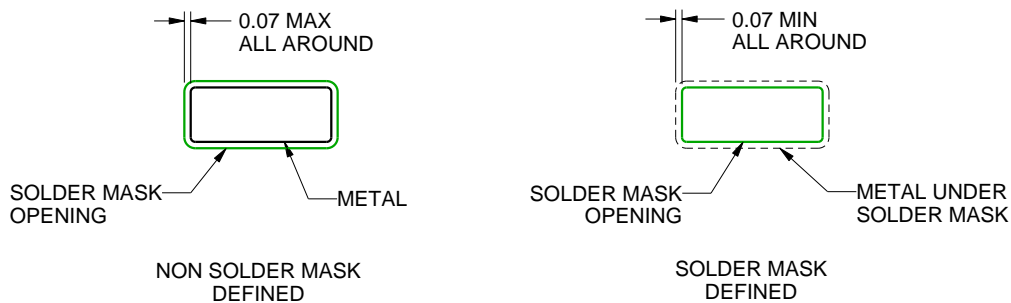

SOLDER MASK DETAILS
PADS 1-8

4214849/A 08/2016

NOTES: (continued)

6. Publication IPC-7351 may have alternate designs.
7. Solder mask tolerances between and around signal pads can vary based on board fabrication site.
8. This package is designed to be soldered to a thermal pad on the board. For more information, see Texas Instruments literature numbers SLMA002 (www.ti.com/lit/slma002) and SLMA004 (www.ti.com/lit/slma004).
9. Size of metal pad may vary due to creepage requirement.
10. Vias are optional depending on application, refer to device data sheet. If any vias are implemented, refer to their locations shown on this view. It is recommended that vias under paste be filled, plugged or tented.

EXAMPLE STENCIL DESIGN

DDA0008B

PowerPAD™ SOIC - 1.7 mm max height

PLASTIC SMALL OUTLINE



SOLDER PASTE EXAMPLE
EXPOSED PAD
100% PRINTED SOLDER COVERAGE BY AREA
SCALE:10X

STENCIL THICKNESS	SOLDER STENCIL OPENING
0.1	3.03 X 3.80
0.125	2.71 X 3.40 (SHOWN)
0.150	2.47 X 3.10
0.175	2.29 X 2.87

4214849/A 08/2016

NOTES: (continued)

11. Laser cutting apertures with trapezoidal walls and rounded corners may offer better paste release. IPC-7525 may have alternate design recommendations.
12. Board assembly site may have different recommendations for stencil design.

EXAMPLE BOARD LAYOUT

NGU0008B

WSON - 0.8 mm max height

PLASTIC SMALL OUTLINE - NO LEAD

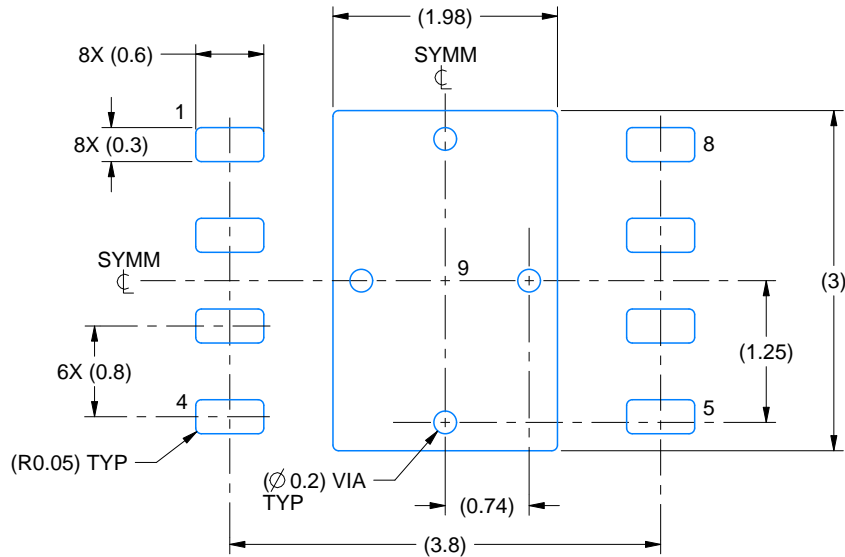

LAND PATTERN EXAMPLE
EXPOSED METAL SHOWN
SCALE:15X

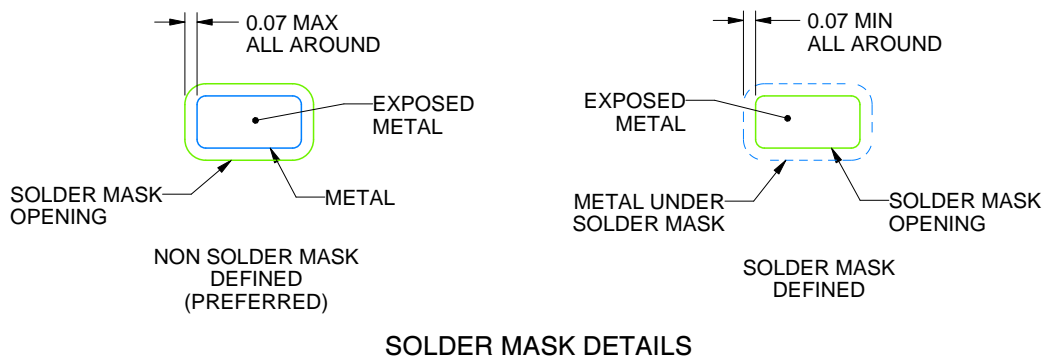

SOLDER MASK DETAILS

4214936/A 12/2023

NOTES: (continued)

4. This package is designed to be soldered to a thermal pad on the board. For more information, see Texas Instruments literature number SLUA271 (www.ti.com/lit/slua271).
5. Vias are optional depending on application, refer to device data sheet. If any vias are implemented, refer to their locations shown on this view. It is recommended that vias under paste be filled, plugged or tented.

EXAMPLE STENCIL DESIGN

NGU0008B

WSON - 0.8 mm max height

PLASTIC SMALL OUTLINE - NO LEAD

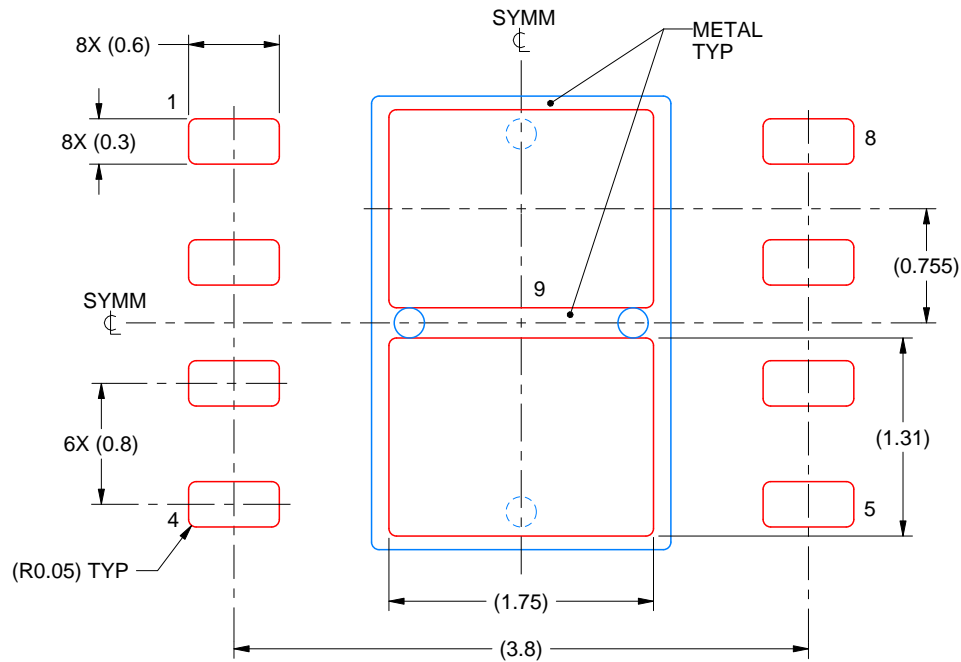

SOLDER PASTE EXAMPLE
BASED ON 0.125 mm THICK STENCIL

EXPOSED PAD 9:
77% PRINTED SOLDER COVERAGE BY AREA UNDER PACKAGE
SCALE:20X

4214936/A 12/2023

NOTES: (continued)

6. Laser cutting apertures with trapezoidal walls and rounded corners may offer better paste release. IPC-7525 may have alternate design recommendations.

重要なお知らせと免責事項

TI は、技術データと信頼性データ(データシートを含みます)、設計リソース(リファレンス・デザインを含みます)、アプリケーションや設計に関する各種アドバイス、Web ツール、安全性情報、その他のリソースを、欠陥が存在する可能性のある「現状のまま」提供しており、商品性および特定目的に対する適合性の黙示保証、第三者の知的財産権の非侵害保証を含むいかなる保証も、明示的または黙示的にかかわらず拒否します。

これらのリソースは、TI 製品を使用する設計の経験を積んだ開発者への提供を意図したものです。(1) お客様のアプリケーションに適した TI 製品の選定、(2) お客様のアプリケーションの設計、検証、試験、(3) お客様のアプリケーションに該当する各種規格や、その他のあらゆる安全性、セキュリティ、規制、または他の要件への確実な適合に関する責任を、お客様のみが単独で負うものとし、

上記の各種リソースは、予告なく変更される可能性があります。これらのリソースは、リソースで説明されている TI 製品を使用するアプリケーションの開発の目的でのみ、TI はその使用をお客様に許諾します。これらのリソースに関して、他の目的で複製することや掲載することは禁止されています。TI や第三者の知的財産権のライセンスが付与されている訳ではありません。お客様は、これらのリソースを自身で使用した結果発生するあらゆる申し立て、損害、費用、損失、責任について、TI およびその代理人を完全に補償するものとし、TI は一切の責任を拒否します。

TI の製品は、[TI の販売条件](#)、または [ti.com](#) やかかる TI 製品の関連資料などのいずれかを通じて提供する適用可能な条項の下で提供されています。TI がこれらのリソースを提供することは、適用される TI の保証または他の保証の放棄の拡大や変更を意味するものではありません。

お客様がいかなる追加条項または代替条項を提案した場合でも、TI はそれらに異議を唱え、拒否します。

郵送先住所 : Texas Instruments, Post Office Box 655303, Dallas, Texas 75265
Copyright © 2024, Texas Instruments Incorporated