

OPAx892 2GHz、10V/V ゲイン安定、0.95nV/ $\sqrt{\text{Hz}}$ 、超低 THD オペアンプ

1 特長

- 0.95nV/ $\sqrt{\text{Hz}}$ の非常に低い電圧ノイズ
- 高速度:
 - ゲイン帯域幅積: 2GHz
 - スルー レート: 700V/ μs
 - 30ns のセトリング タイム (0.1%)
- 10V/V 以上のゲインで安定
- 出力駆動、 $I_O = 200\text{mA}$ (標準値)
- 非常に低い歪み:
 - THD = -78dBc ($f = 1\text{MHz}$, $R_L = 150\Omega$)
 - THD+N = -114dBc ($f = 1\text{kHz}$, $\text{BW} = 80\text{kHz}$)
- 広範な電源:
 - $V_{CC} = \pm 4.5\text{V} \sim \pm 18\text{V}$
- OPA892 のオフセット ヌルピン

2 アプリケーション

- 超音波スキャナ
- ソース メジャー ユニット (SMU)
- 電力品質メータ
- 超音波スキャナ
- ベクトル信号トランシーバ (VST)
- 業務用オーディオ ミキサまたは制御卓
- 業務用マイク/ワイヤレス システム
- 業務用スピーカ システム
- 業務用オーディオ アンプ
- サウンドバー
- ターンテーブル
- 業務用ビデオ カメラ
- ギターおよびその他楽器用アンプ
- データ アクイジション (DAQ)

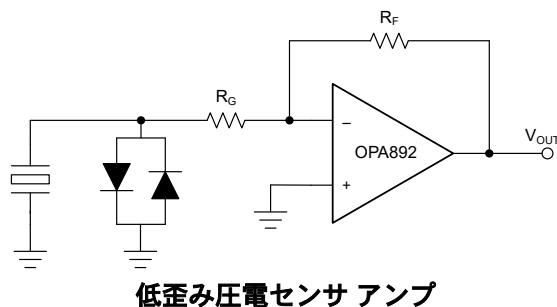

3 概要

OPA892 および OPA2892 (OPAx892) は電圧ノイズが非常に低い高速電圧帰還アンプで、通信やイメージングなど低い電圧ノイズが要求されるアプリケーションに最適です。シングルアンプの OPA892 とデュアルアンプの OPA2892 は AC 性能が非常に優れており、10V/V のゲインで 290MHz の帯域幅、700V/ μs のスルーレート、30ns のセトリング タイム (0.1%) を実現します。OPAx892 は、10 以上および -9 以下のゲインで安定しています。これらのアンプには、200mA の大きな駆動能力があり、アンプごとに 7.5mA の電流しか消費しません。f = 1MHz において全高調波歪み (THD) が -68dBc である OPAx892 は、低歪みを必要とするアプリケーション用に設計されています。広い出力電圧範囲にわたって低歪みを維持するため、OPAx892 はイメージング、ソナー、オーディオなどの広いダイナミックレンジのアプリケーションに有用です。

製品情報

| 部品番号 | アンプ | パッケージ (1) | パッケージ サイズ (2) |
|---------|-----|-----------------|---------------|
| OPA892 | 1 | D (SOIC, 8) | 4.9mm × 6mm |
| OPA2892 | 2 | DGN (HVSSOP, 8) | 3mm × 4.9mm |

- 詳細については、[セクション 10](#) を参照してください。
- パッケージ サイズ (長さ × 幅) は公称値であり、該当する場合はピンも含まれます。

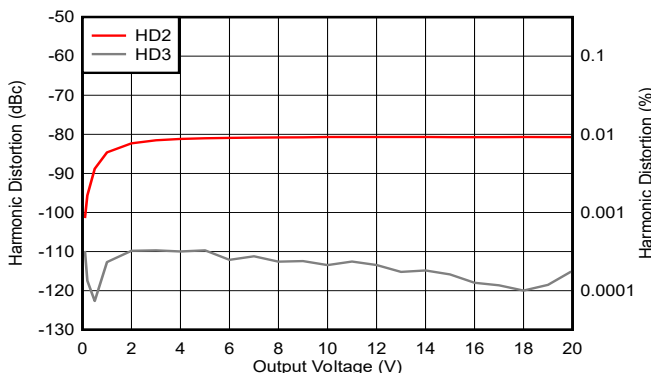

高調波歪みと ピーク ツー ピークの出力電圧との関係



Table of Contents

| | | | |
|--|-----------|--|-----------|
| 1 特長 | 1 | 7 Application and Implementation | 16 |
| 2 アプリケーション | 1 | 7.1 Application Information..... | 16 |
| 3 概要 | 1 | 7.2 Typical Application..... | 17 |
| 4 Pin Configuration and Functions | 3 | 7.3 Power Supply Recommendations..... | 19 |
| 5 Specifications | 4 | 7.4 Layout..... | 19 |
| 5.1 Absolute Maximum Ratings..... | 4 | 8 Device and Documentation Support | 23 |
| 5.2 ESD Ratings..... | 4 | 8.1 Documentation Support..... | 23 |
| 5.3 Recommended Operating Conditions..... | 4 | 8.2 ドキュメントの更新通知を受け取る方法..... | 23 |
| 5.4 Thermal Information..... | 4 | 8.3 サポート・リソース..... | 23 |
| 5.5 Electrical Characteristics..... | 5 | 8.4 Trademarks..... | 23 |
| 5.6 Typical Characteristics..... | 7 | 8.5 静電気放電に関する注意事項..... | 23 |
| 6 Detailed Description | 14 | 8.6 用語集..... | 23 |
| 6.1 Overview..... | 14 | 9 Revision History | 23 |
| 6.2 Functional Block Diagram..... | 14 | 10 Mechanical, Packaging, and Orderable Information | 24 |
| 6.3 Feature Description..... | 15 | | |
| 6.4 Device Functional Modes..... | 15 | | |

4 Pin Configuration and Functions



図 4-1. OPA892: D Package, 8-Pin SOIC (Top View)

表 4-1. Pin Functions: OPA892

| PIN | | TYPE | DESCRIPTION |
|------|------|--------|-----------------------|
| NAME | NO. | | |
| IN- | 2 | Input | Inverting input |
| IN+ | 3 | Input | Noninverting input |
| NC | 5 | — | No connection |
| NULL | 1, 8 | Input | Voltage offset adjust |
| OUT | 6 | Output | Output of amplifier |
| VCC- | 4 | — | Negative power supply |
| VCC+ | 7 | — | Positive power supply |

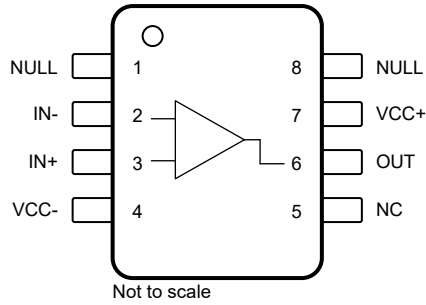

図 4-2. OPA2892: DGN Package, 8-pin HVSSOP (Top View)

表 4-2. Pin Functions: OPA2892

| PIN | | TYPE | DESCRIPTION |
|-------------|-----|--------|--|
| NAME | NO. | | |
| 1IN- | 2 | Input | Channel 1 inverting input |
| 1IN+ | 3 | Input | Channel 1 noninverting input |
| 1OUT | 1 | Output | Channel 1 output |
| 2IN- | 6 | Input | Channel 2 inverting input |
| 2IN+ | 5 | Input | Channel 2 noninverting input |
| 2OUT | 7 | Output | Channel 2 output |
| VCC- | 4 | — | Negative power supply |
| VCC+ | 8 | — | Positive power supply |
| Thermal pad | | — | Thermal pad. DGN (HVSSOP) package only. For best thermal performance, connect pad to large copper plane. Thermal pad can be connected to any pin on the device, or any other potential on the board if voltage on thermal pad remains between VCC+ and VCC-. |

5 Specifications

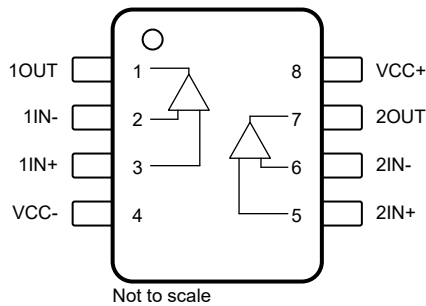
5.1 Absolute Maximum Ratings

over operating free-air temperature range (unless otherwise noted)⁽¹⁾

| | | MIN | MAX | UNIT |
|------------------|---|--|------------------|------|
| V _{CC} | Supply voltage, V _{CC+} – V _{CC-} | | 37 | V |
| V _I | Input voltage | | ±V _{CC} | V |
| I _O | Output current ⁽²⁾ | | 240 | mA |
| V _{IO} | Differential input voltage | | ±1.5 | V |
| I _{IN} | Continuous input current | | 10 | mA |
| T _J | Junction temperature | Any condition | 150 | °C |
| | | Continuous operation, long-term reliability ⁽³⁾ | 125 | |
| T _{stg} | Storage temperature | –65 | 150 | °C |

- (1) Operation outside the *Absolute Maximum Ratings* may cause permanent device damage. *Absolute Maximum Ratings* do not imply functional operation of the device at these or any other conditions beyond those listed under *Recommended Operating Conditions*. If used outside the *Recommended Operating Conditions* but within the *Absolute Maximum Ratings*, the device may not be fully functional, and this may affect device reliability, functionality, performance, and shorten the device lifetime.
- (2) When continuously operating at any output current, do not exceed the maximum junction temperature. Keep the output current less than the absolute maximum rating regardless of time interval.
- (3) The maximum junction temperature for continuous operation is limited by package constraints. Operation greater than this temperature can result in reduced reliability, lifetime of the device, or both.

5.2 ESD Ratings

| | | | VALUE | UNIT |
|--------------------|-------------------------|---|-------|------|
| V _(ESD) | Electrostatic discharge | Human body model (HBM), per ANSI/ESDA/JEDEC JS-001, all pins ⁽¹⁾ | ±4000 | V |
| | | Charged device model (CDM), per ANSI/ESDA/JEDEC JS-002, all pins ⁽²⁾ | ±1500 | |

- (1) JEDEC document JEP155 states that 500-V HBM allows safe manufacturing with a standard ESD control process.
- (2) JEDEC document JEP157 states that 250-V CDM allows safe manufacturing with a standard ESD control process.

5.3 Recommended Operating Conditions

over operating free-air temperature range (unless otherwise noted)

| | | | MIN | NOM | MAX | UNIT |
|-----------------|--------------------------------|---------------|------|-----|-----|------|
| V _{CC} | Supply voltage | Dual-supply | ±4.5 | ±15 | ±18 | V |
| | | Single-supply | 9 | 30 | 36 | |
| T _A | Operating free-air temperature | | –40 | 25 | 85 | °C |

5.4 Thermal Information

| THERMAL METRIC ⁽¹⁾ | | OPA892 | OPA2892 | UNIT |
|-------------------------------|--|----------|--------------|------|
| | | D (SOIC) | DGN (HVSSOP) | |
| | | 8 PINS | 8 PINS | |
| R _{θJA} | Junction-to-ambient thermal resistance | 124.5 | 52 | °C/W |
| R _{θJC(top)} | Junction-to-case (top) thermal resistance | 65.0 | 75.2 | °C/W |
| R _{θJB} | Junction-to-board thermal resistance | 72.2 | 24.5 | °C/W |
| Ψ _{JT} | Junction-to-top characterization parameter | 13.6 | 4 | °C/W |
| Ψ _{JB} | Junction-to-board characterization parameter | 71.4 | 24.5 | °C/W |
| R _{θJC(bot)} | Junction-to-case (bottom) thermal resistance | N/A | 9.1 | °C/W |

- (1) For information about traditional and new thermal metrics, see the [Semiconductor and IC Package Thermal Metrics](#) application report.

5.5 Electrical Characteristics

at $T_A = 25^\circ\text{C}$, $V_{CC} = \pm 15\text{ V}$, and $R_L = 150\ \Omega$ (unless otherwise noted)

| PARAMETER | | TEST CONDITIONS | | MIN | TYP | MAX | UNIT | |
|---|--|--|---|--------------------------|---------|-----|------------------------|--|
| DYNAMIC PERFORMANCE | | | | | | | | |
| BW | Small-signal bandwidth (-3 dB) | Gain = 10 | $V_{CC} = \pm 15\text{ V}$ | | 290 | | MHz | |
| | | | $V_{CC} = \pm 5\text{ V}$ | | 250 | | | |
| | | Gain = 20 | $V_{CC} = \pm 15\text{ V}$ | | 110 | | | |
| | | | $V_{CC} = \pm 5\text{ V}$ | | 100 | | | |
| | Bandwidth for 0.1-dB flatness | Gain = 10 | $V_{CC} = \pm 15\text{ V}$ | | 17 | | | |
| | | | $V_{CC} = \pm 5\text{ V}$ | | 17 | | | |
| Full power bandwidth ⁽¹⁾ | | $V_{O(PP)} = 20\text{ V}$, $V_{CC} = \pm 15\text{ V}$ | | | 11.1 | | | |
| | | $V_{O(PP)} = 5\text{ V}$, $V_{CC} = \pm 5\text{ V}$ | | | 31.8 | | | |
| SR | Slew rate ⁽²⁾ | Gain = 10 | $V_{CC} = \pm 15\text{ V}$, 20-V step | | 700 | | V/ μs | |
| | | | $V_{CC} = \pm 5\text{ V}$, 5-V step | | 500 | | | |
| t_s | Settling time to 0.1% | Gain = -10 | $V_{CC} = \pm 15\text{ V}$, 5-V step | | 22 | | ns | |
| | | | $V_{CC} = \pm 5\text{ V}$, 2-V step | | 22 | | | |
| | Settling time to 0.01% | Gain = -10 | $V_{CC} = \pm 15\text{ V}$, 5-V step | | 160 | | | |
| | | | $V_{CC} = \pm 5\text{ V}$, 2-V step | | 160 | | | |
| AUDIO PERFORMANCE | | | | | | | | |
| THD+N | Total harmonic distortion + noise | Gain = 10, $f = 1\text{ kHz}$, BW = 80 kHz | $V_{CC} = \pm 15\text{ V}$, $R_L = 600\ \Omega$, $V_O = 3\text{ V}_{RMS}$ | | -114 | | dB | |
| | | | | | 0.0002 | | % | |
| | | | $V_{CC} = \pm 15\text{ V}$, $R_L = 2\text{ k}\Omega$, $V_O = 3\text{ V}_{RMS}$ | | -114 | | dB | |
| | | | | | 0.0002 | | % | |
| | | | $V_{CC} = \pm 5\text{ V}$, $R_L = 600\ \Omega$, $V_O = 1\text{ V}_{RMS}$ | | -106 | | dB | |
| | | | | | 0.0005 | | % | |
| IMD | Intermodulation distortion | Gain = 10, SMPTE/DIN two-tone, 4:1 (60 Hz and 7 kHz) | $V_{CC} = \pm 15\text{ V}$, $V_O = 3\text{ V}_{RMS}$, $R_L = 600\ \Omega$ | | -109 | | dB | |
| | | | | | 0.00036 | | % | |
| | | | $V_{CC} = \pm 15\text{ V}$, $V_O = 3\text{ V}_{RMS}$, $R_L = 2\text{ k}\Omega$ | | -109 | | dB | |
| | | | | | 0.00036 | | % | |
| | | | $V_{CC} = \pm 5\text{ V}$, $V_O = 1\text{ V}_{RMS}$, $R_L = 600\ \Omega$ | | -105 | | dB | |
| | | | | | 0.00056 | | % | |
| | | | $V_{CC} = \pm 5\text{ V}$, $V_O = 1\text{ V}_{RMS}$, $R_L = 2\text{ k}\Omega$ | | -105 | | dB | |
| | | | | | 0.00056 | | % | |
| NOISE AND DISTORTION PERFORMANCE | | | | | | | | |
| THD | Total harmonic distortion | $V_{O(PP)} = 2\text{ V}$, $f = 1\text{ MHz}$, gain = 10, $V_{CC} = \pm 15\text{ V}$ | $R_L = 1\text{ k}\Omega$ | | -78 | | dBc | |
| | | | | | -86 | | | |
| | | | $V_{O(PP)} = 2\text{ V}$, $f = 1\text{ MHz}$, gain = 10, $V_{CC} = \pm 5\text{ V}$ | $R_L = 1\text{ k}\Omega$ | | -77 | | |
| | | | | | | -85 | | |
| V_n | Input voltage noise | $V_{CC} = \pm 5\text{ V}$ or $\pm 15\text{ V}$, $f > 10\text{ kHz}$ | | | 0.95 | | nV/ $\sqrt{\text{Hz}}$ | |
| I_n | Input current noise | $V_{CC} = \pm 5\text{ V}$ or $\pm 15\text{ V}$, $f > 10\text{ kHz}$ | | | 2.3 | | pA/ $\sqrt{\text{Hz}}$ | |
| X_T | Channel-to-channel crosstalk (OPA2892 only) | $V_{CC} = \pm 5\text{ V}$ or $\pm 15\text{ V}$, $f = 1\text{ MHz}$ | | | -54 | | dBc | |

5.5 Electrical Characteristics (続き)

at $T_A = 25^\circ\text{C}$, $V_{CC} = \pm 15\text{ V}$, and $R_L = 150\ \Omega$ (unless otherwise noted)

| PARAMETER | | TEST CONDITIONS | | MIN | TYP | MAX | UNIT |
|-------------------------------|----------------------------------|--|----------------------------|------------|------------|-----|------------------------------|
| DC PERFORMANCE | | | | | | | |
| | Open-loop gain | $V_{CC} = \pm 15\text{ V}$, $V_O = \pm 10\text{ V}$, $R_L = 1\text{ k}\Omega$ | $T_A = 25^\circ\text{C}$ | 93 | 100 | | dB |
| | | | $T_A = \text{full range}$ | 92 | | | dB |
| | | $V_{CC} = \pm 5\text{ V}$, $V_O = \pm 2.5\text{ V}$, $R_L = 1\text{ k}\Omega$ | $T_A = 25^\circ\text{C}$ | 92 | 98 | | dB |
| | | | $T_A = \text{full range}$ | 91 | | | dB |
| V_{OS} | Input offset voltage | $V_{CC} = \pm 5\text{ V}$ or $\pm 15\text{ V}$, $T_A = 25^\circ\text{C}$ | | | 0.2 | 1 | mV |
| | Offset voltage drift | $V_{CC} = \pm 5\text{ V}$ or $\pm 15\text{ V}$, $T_A = \text{full range}$ | | | 1 | | $\mu\text{V}/^\circ\text{C}$ |
| I_{IB} | Input bias current | $V_{CC} = \pm 5\text{ V}$ or $\pm 15\text{ V}$ | $T_A = 25^\circ\text{C}$ | | 9 | 20 | μA |
| | | | $T_A = \text{full range}$ | | | 33 | μA |
| I_{OS} | Input offset current | $V_{CC} = \pm 5\text{ V}$ or $\pm 15\text{ V}$ | $T_A = 25^\circ\text{C}$ | | 30 | 250 | nA |
| | | | $T_A = \text{full range}$ | | | 400 | nA |
| | Input offset current drift | $V_{CC} = \pm 5\text{ V}$ or $\pm 15\text{ V}$, $T_A = \text{full range}$ | | | 0.2 | | $\text{nA}/^\circ\text{C}$ |
| INPUT CHARACTERISTICS | | | | | | | |
| V_{ICR} | Common-mode input voltage | $V_{CC} = \pm 15\text{ V}$ | | ± 13.8 | ± 14.3 | | V |
| | | $V_{CC} = \pm 5\text{ V}$ | | ± 3.8 | ± 4.3 | | |
| CMRR | Common-mode rejection ratio | $V_{CC} = \pm 15\text{ V}$, $V_{ICR} = \pm 12\text{ V}$ | $T_A = 25^\circ\text{C}$ | 85 | 104 | | dB |
| | | | $T_A = \text{full range}$ | 80 | | | |
| | | $V_{CC} = \pm 5\text{ V}$, $V_{ICR} = \pm 2.5\text{ V}$ | $T_A = 25^\circ\text{C}$ | 90 | 106 | | |
| | | | $T_A = \text{full range}$ | 85 | | | |
| | Input impedance | Common-mode | | 10 1.2 | | | $\text{M}\Omega$ pF |
| | | Differential-mode | | 6 1.8 | | | $\text{k}\Omega$ pF |
| OUTPUT CHARACTERISTICS | | | | | | | |
| V_O | Output voltage swing | $V_{CC} = \pm 15\text{ V}$, $R_L = 250\ \Omega$ | | ± 12 | ± 12.9 | | V |
| | | $V_{CC} = \pm 5\text{ V}$, $R_L = 150\ \Omega$ | | ± 3 | ± 3.5 | | |
| | | $V_{CC} = \pm 15\text{ V}$, $R_L = 1\text{ k}\Omega$ | | ± 13 | ± 13.6 | | |
| | | $V_{CC} = \pm 5\text{ V}$, $R_L = 1\text{ k}\Omega$ | | ± 3.4 | ± 3.8 | | |
| I_O | Output current | $R_L = 10\ \Omega$ | $V_{CC} = \pm 15\text{ V}$ | 160 | 200 | | mA |
| | | | $V_{CC} = \pm 5\text{ V}$ | 120 | 160 | | |
| R_O | Output resistance ⁽³⁾ | Open-loop | | | 8 | | Ω |
| POWER SUPPLY | | | | | | | |
| I_{CC} | Supply current (per amplifier) | $V_{CC} = \pm 15\text{ V}$ | $T_A = 25^\circ\text{C}$ | | 7.5 | 10 | mA |
| | | | $T_A = \text{full range}$ | | | 11 | |
| | | $V_{CC} = \pm 5\text{ V}$ | $T_A = 25^\circ\text{C}$ | | 9 | | |
| | | | $T_A = \text{full range}$ | | 6.5 | 10 | |
| PSRR | Power-supply rejection ratio | $V_{CC} = \pm 5\text{ V}$ or $\pm 15\text{ V}$ | $T_A = 25^\circ\text{C}$ | 90 | 105 | | dB |
| | | | $T_A = \text{full range}$ | 85 | | | |

(1) Full-power bandwidth = slew rate / $[\pi V_{O(P-P)}]$.

(2) Slew rate is measured from an output level range of 25% to 75%.

(3) Keep junction temperature less than the absolute maximum rating when the output is heavily loaded or shorted; see also [セクション 5.1](#).

5.6 Typical Characteristics

at $T_A = 25^\circ\text{C}$, $V_{CC} = \pm 15\text{ V}$, gain = +10 V/V, $R_L = 150\ \Omega$, and $R_F = 220\ \Omega$ (unless otherwise noted)

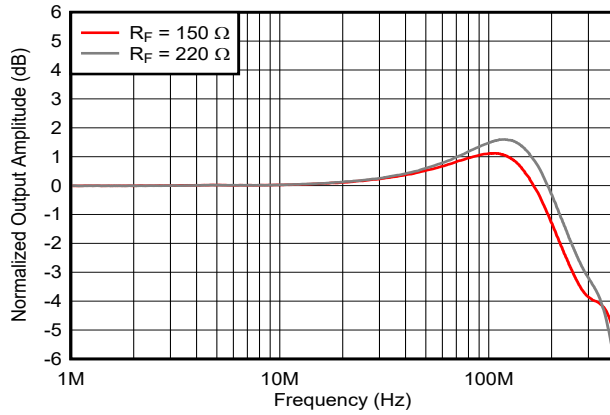

Figure 5-1. Frequency Response vs Feedback Resistance

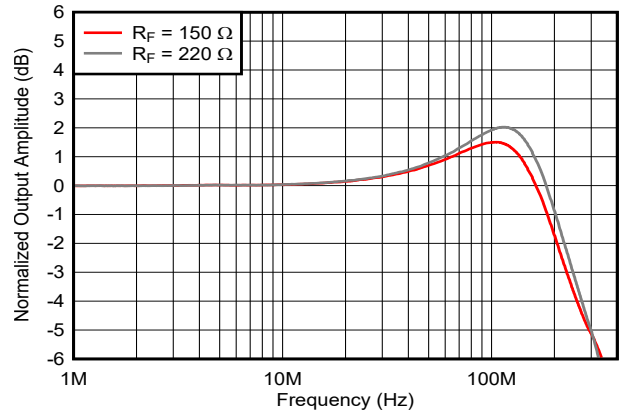

Figure 5-2. Frequency Response vs Feedback Resistance

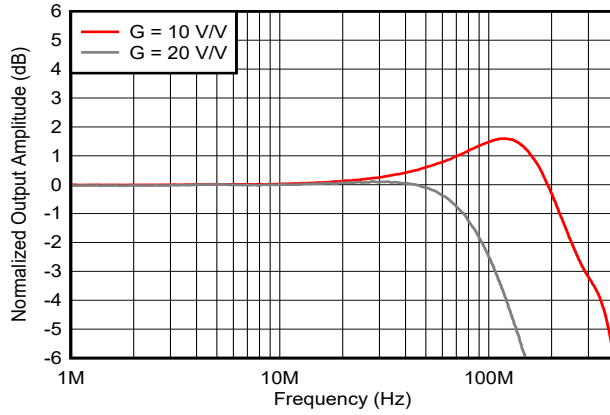

Figure 5-3. Frequency Response vs Gain

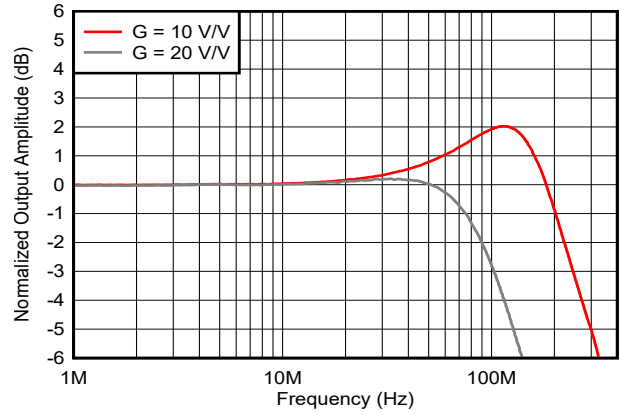

Figure 5-4. Frequency Response vs Gain

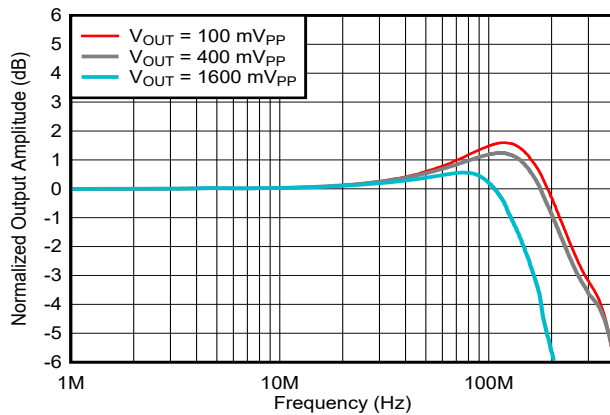

Figure 5-5. Large-signal Frequency Response

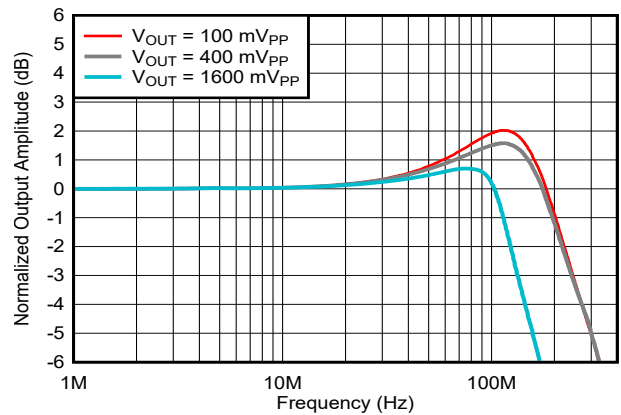
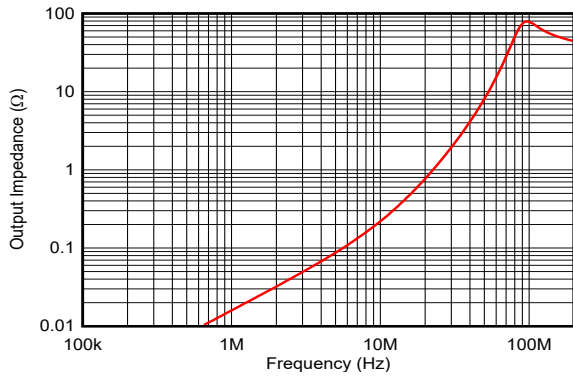

Figure 5-6. Large-signal Frequency Response

5.6 Typical Characteristics (continued)

at $T_A = 25^\circ\text{C}$, $V_{CC} = \pm 15\text{ V}$, gain = +10 V/V, $R_L = 150\ \Omega$, and $R_F = 220\ \Omega$ (unless otherwise noted)



5-7. Closed-loop Output Impedance

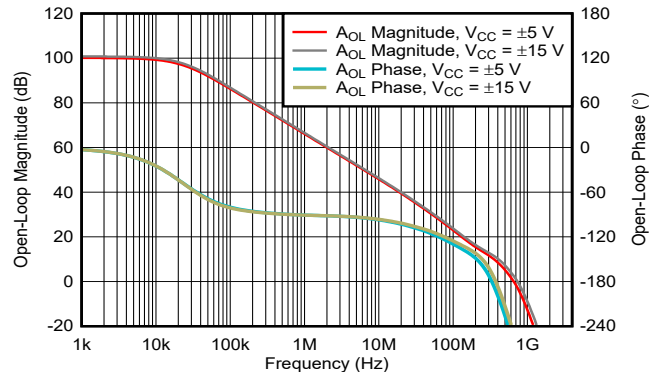

5-8. Open-loop Gain and Phase Response

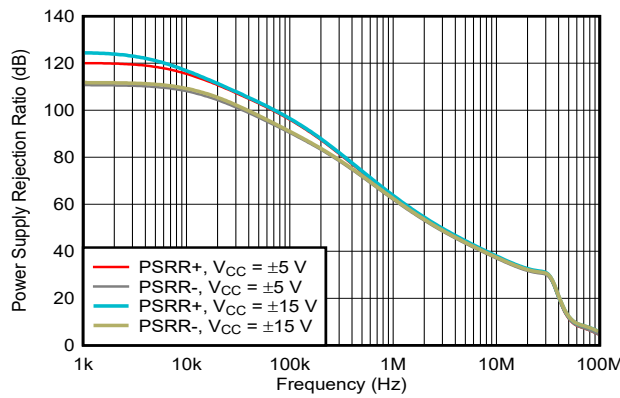

5-9. Power-Supply Rejection Ratio vs Frequency

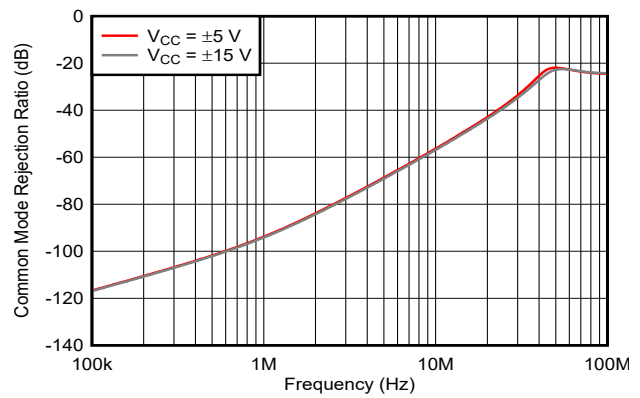

5-10. Common-mode Rejection Ratio vs Frequency

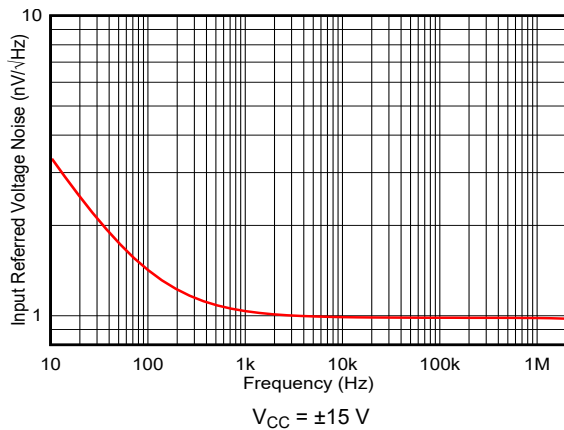

5-11. Input-referred Voltage Noise vs Frequency

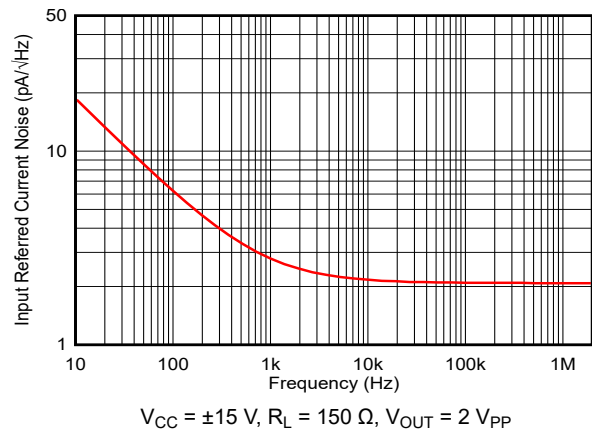

5-12. Input-referred Current Noise vs Frequency

5.6 Typical Characteristics (continued)

at $T_A = 25^\circ\text{C}$, $V_{CC} = \pm 15\text{ V}$, gain = +10 V/V, $R_L = 150\ \Omega$, and $R_F = 220\ \Omega$ (unless otherwise noted)

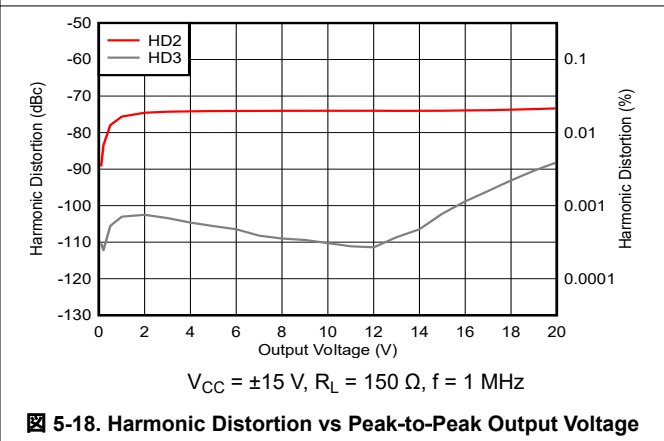
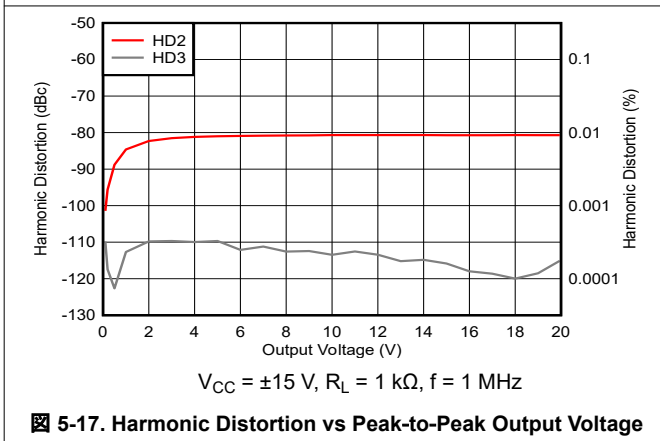
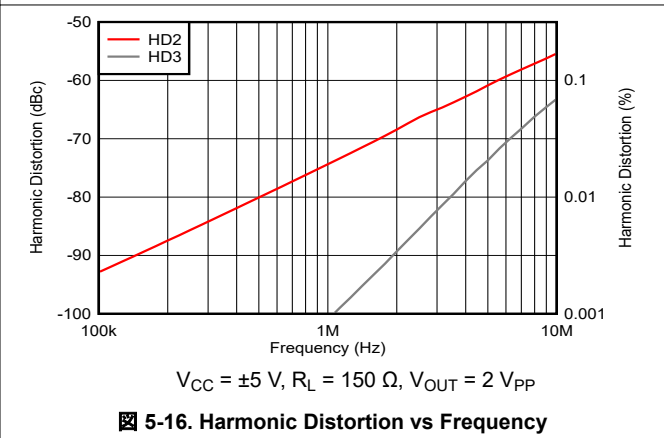
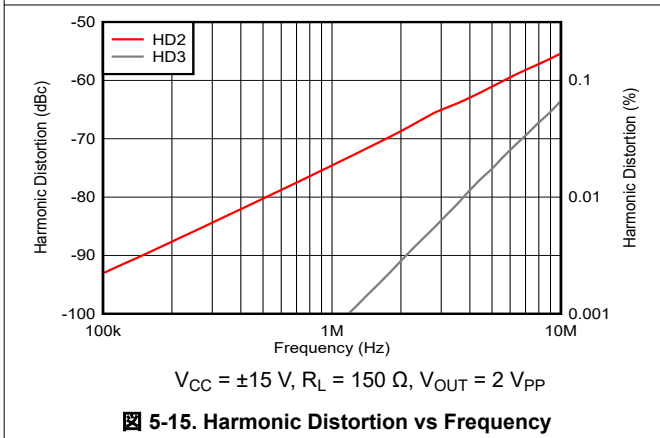
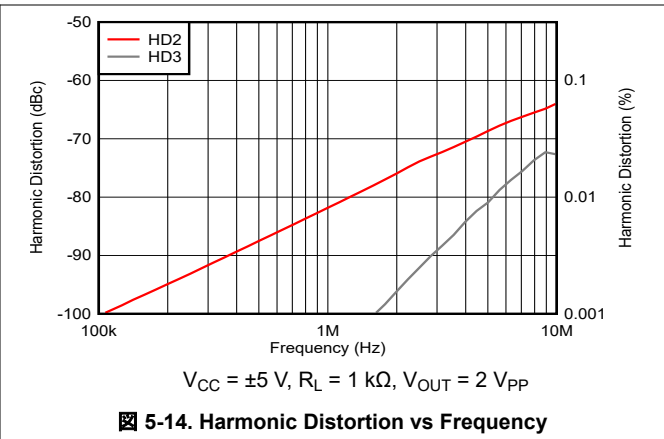
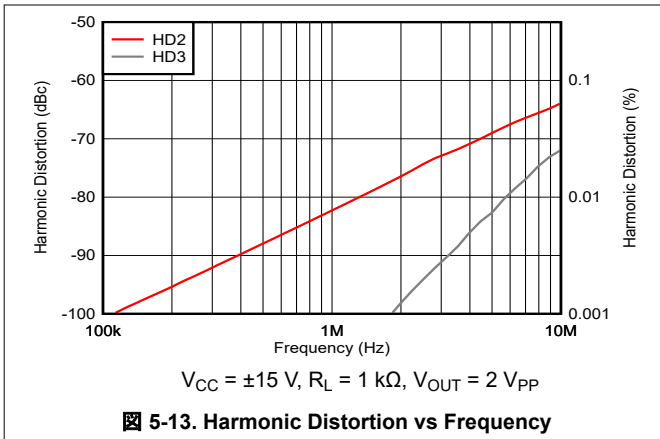

5.6 Typical Characteristics (continued)

at $T_A = 25^\circ\text{C}$, $V_{CC} = \pm 15\text{ V}$, gain = +10 V/V, $R_L = 150\ \Omega$, and $R_F = 220\ \Omega$ (unless otherwise noted)

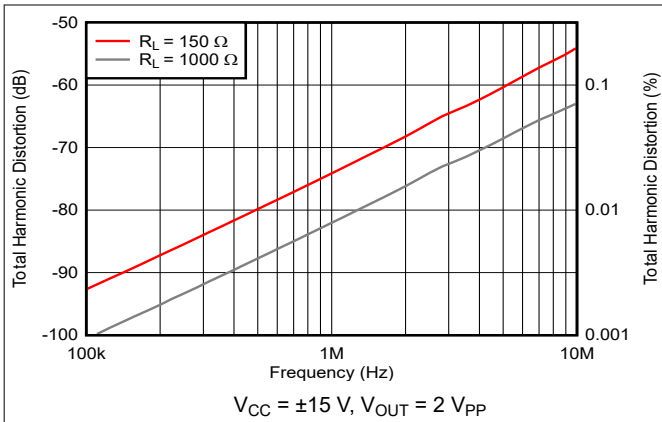

5-19. Total Harmonic Distortion vs Frequency

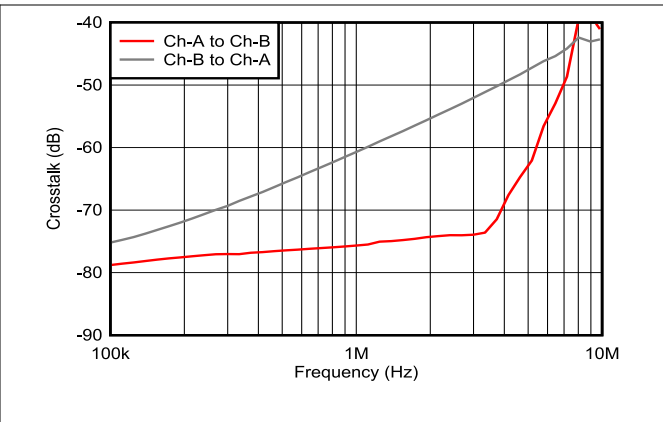

5-20. OPA2892 Crosstalk vs Frequency

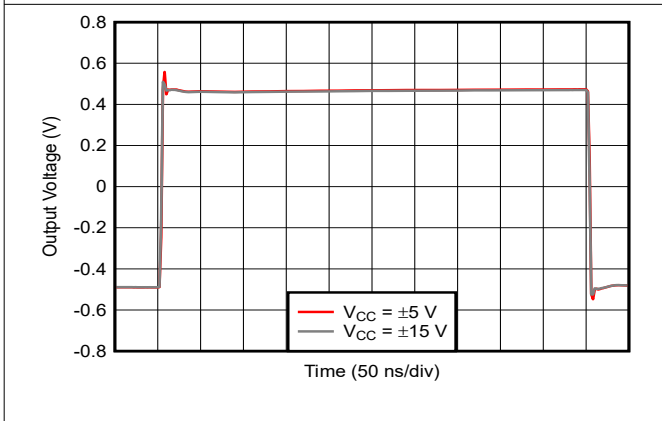

5-21. 1-V Step Response

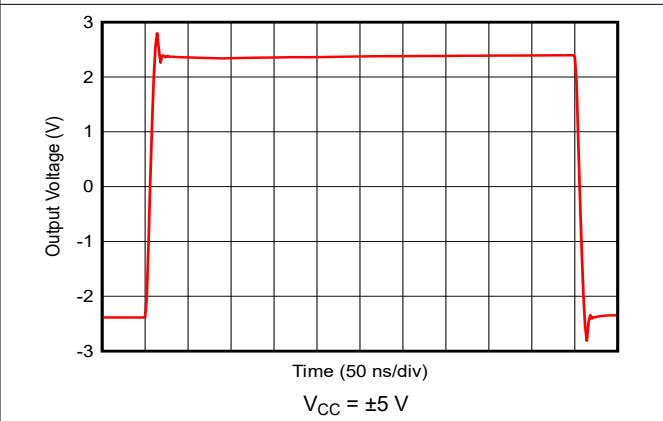

5-22. 5-V Step Response

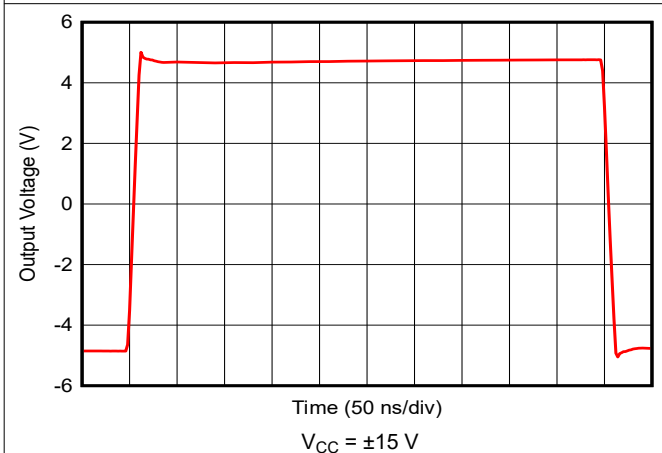

5-23. 10-V Step Response

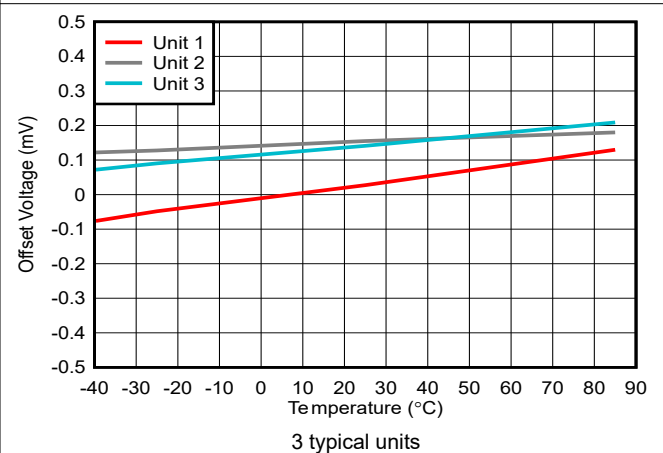

5-24. Input Offset Voltage vs Ambient Temperature

5.6 Typical Characteristics (continued)

at $T_A = 25^\circ\text{C}$, $V_{CC} = \pm 15\text{ V}$, gain = +10 V/V, $R_L = 150\ \Omega$, and $R_F = 220\ \Omega$ (unless otherwise noted)

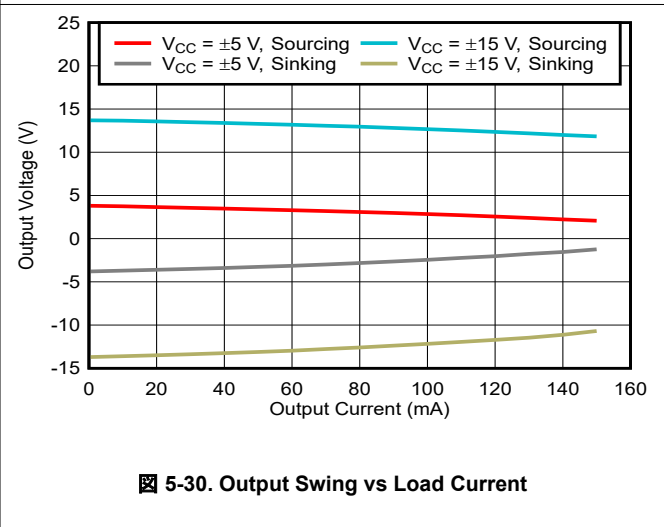
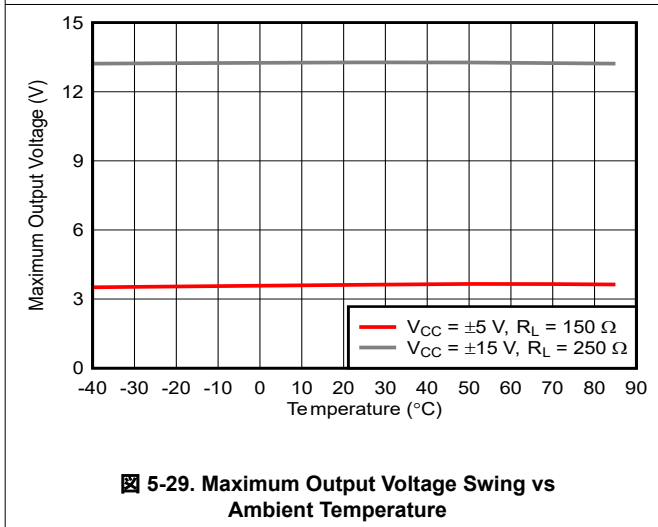
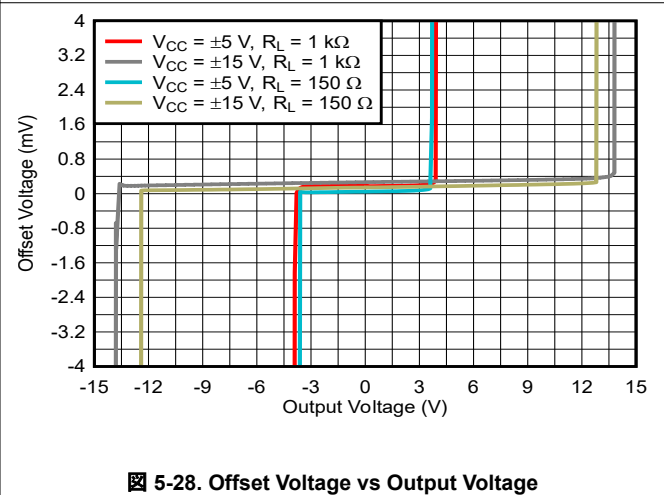
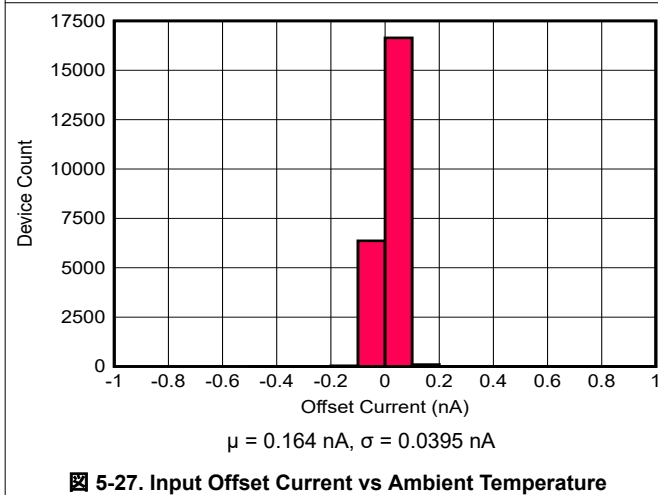
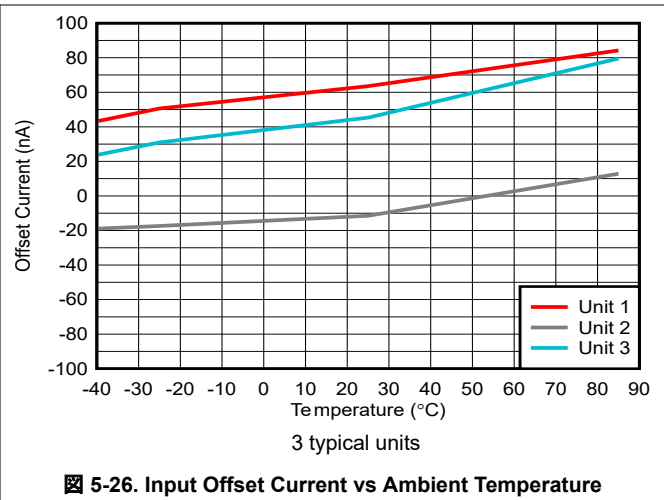
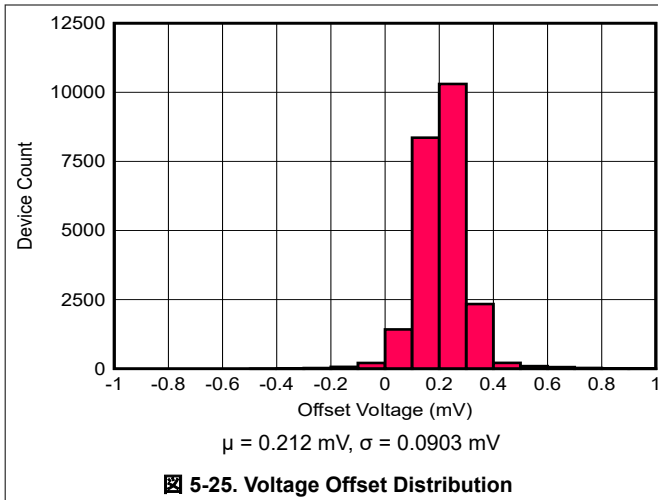

5.6 Typical Characteristics (continued)

at $T_A = 25^\circ\text{C}$, $V_{CC} = \pm 15\text{ V}$, gain = +10 V/V, $R_L = 150\ \Omega$, and $R_F = 220\ \Omega$ (unless otherwise noted)



图 5-31. Supply Current vs Ambient Temperature



图 5-32. THD+N vs Frequency

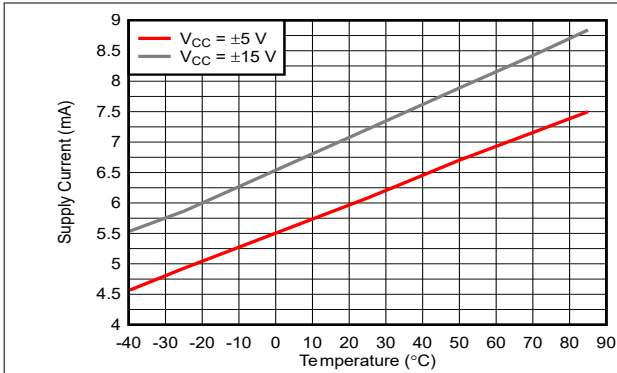

图 5-33. THD+N Ratio vs Output Amplitude

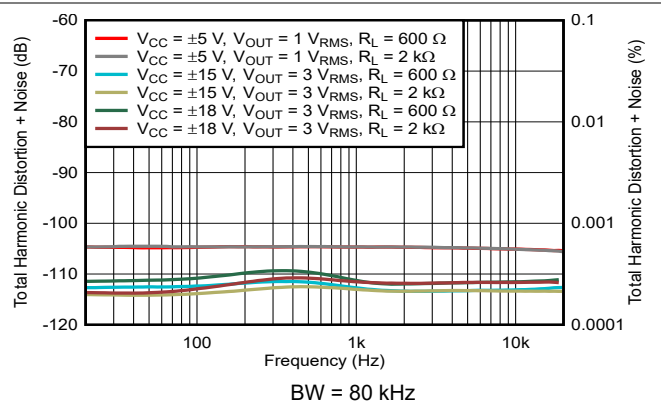

图 5-34. Intermodulation Distortion vs Amplitude

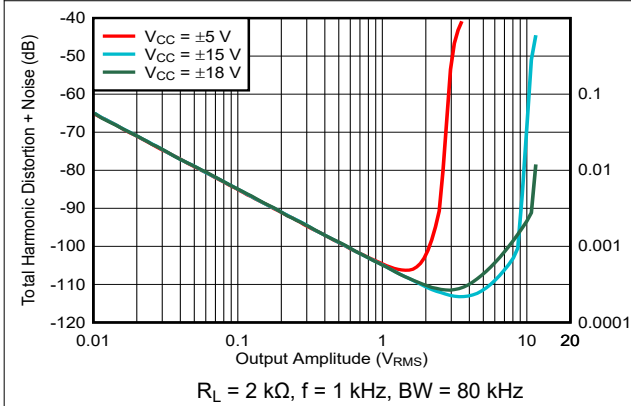

图 5-35. Distortion Harmonics vs Frequency

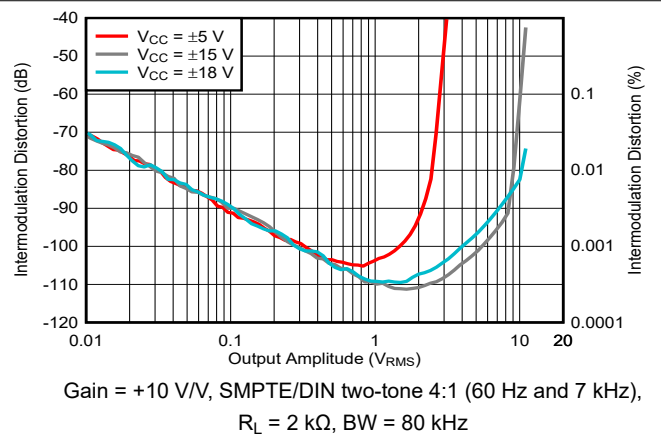

图 5-36. Distortion Harmonics vs Frequency

5.6 Typical Characteristics (continued)

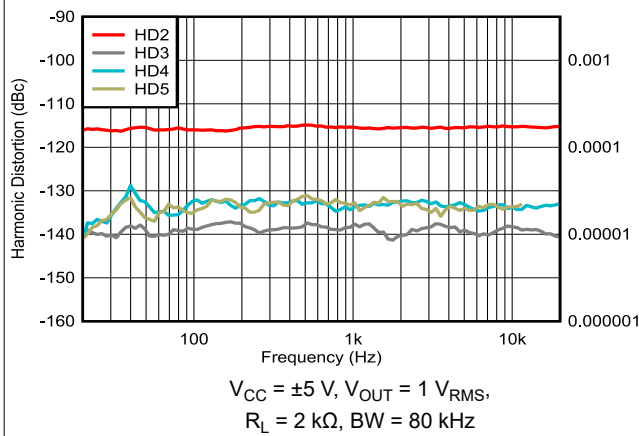
at $T_A = 25^\circ\text{C}$, $V_{CC} = \pm 15\text{ V}$, gain = +10 V/V, $R_L = 150\ \Omega$, and $R_F = 220\ \Omega$ (unless otherwise noted)

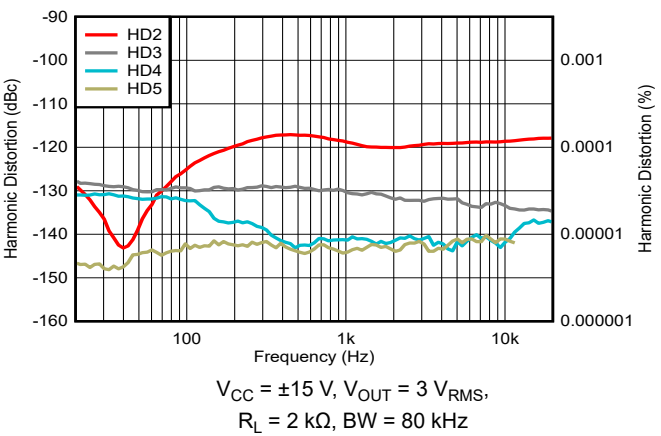
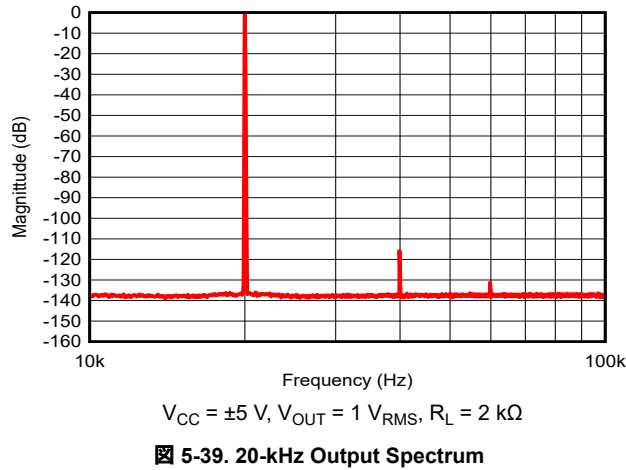
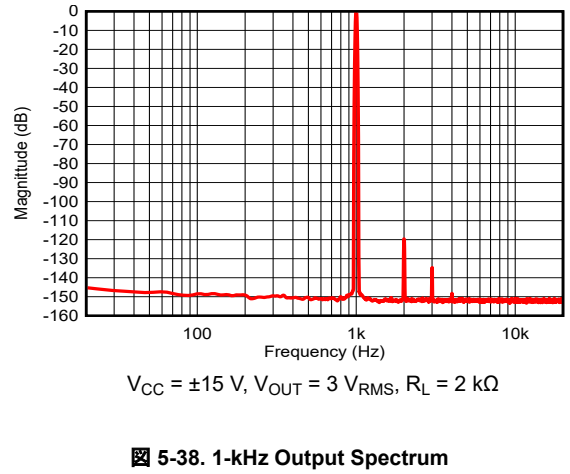
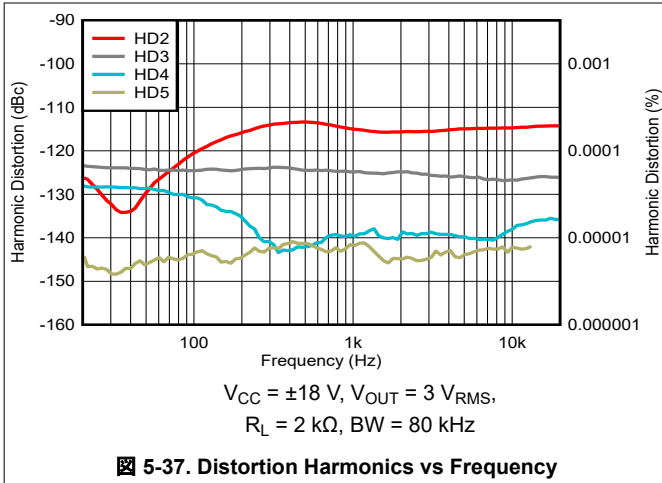

6 Detailed Description

6.1 Overview

The OPAx892 are high-speed operational amplifiers configured in a decompensated voltage-feedback architecture. The OPAx892 are stable with gain configurations of 10 V/V or greater. These amplifiers are built using a greater than 30-V, complementary, bipolar process with NPN and PNP transistors possessing an f_T of several GHz. This configuration results in exceptionally high-performance amplifiers with wide bandwidth, high slew rate, fast settling time, and low distortion.

6.2 Functional Block Diagram



图 6-1. OPA892: Single Channel



图 6-2. OPA2892: Dual Channel

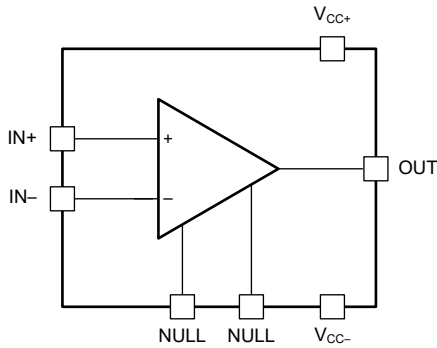

图 6-3. OPA892 Simplified Schematic

6.3 Feature Description

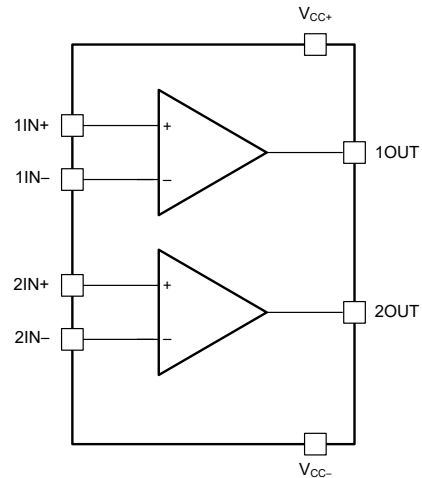
6.3.1 Offset Nulling

The OPAx892 have a very low input offset voltage for high-speed amplifiers. However, if additional correction is required, an offset nulling function is provided on the OPA892. To adjust the input offset voltage, place a potentiometer between pin 1 and pin 8 of the device, and tie the wiper to the negative supply. [Figure 6-4](#) shows this feature.

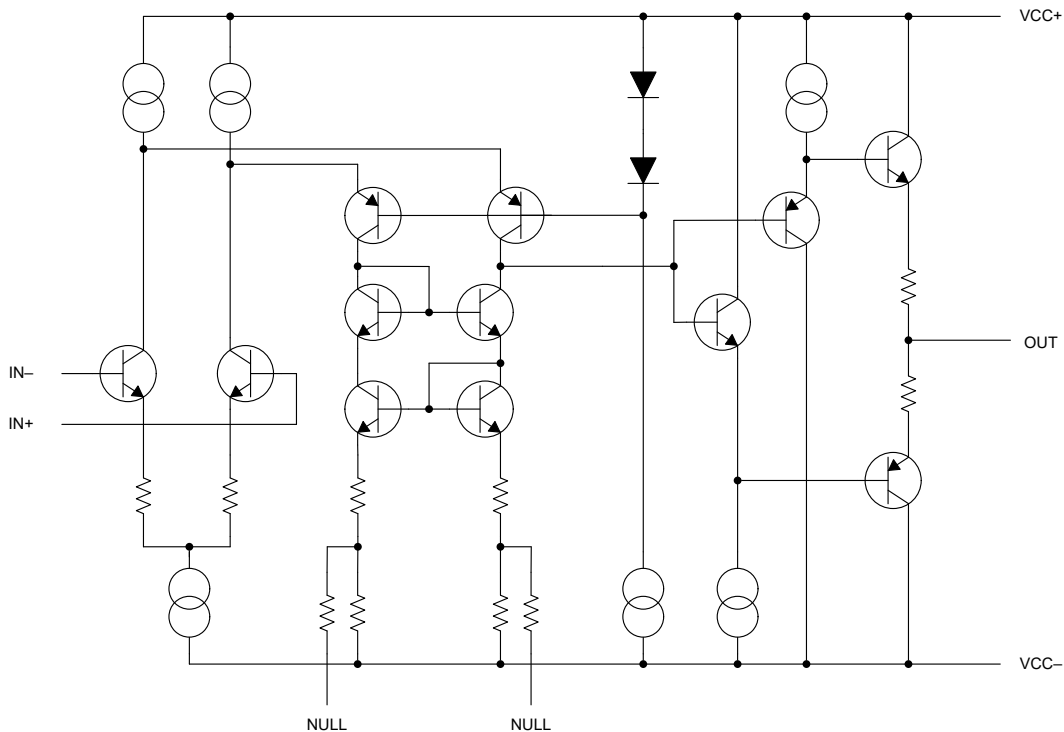
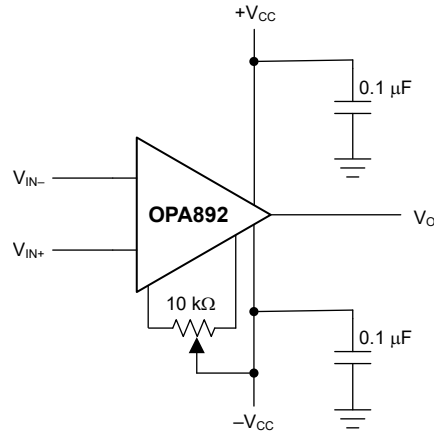

Figure 6-4. Offset Nulling Schematic

6.4 Device Functional Modes

The OPAx892 family has a single functional mode and can be used with both single-supply or split power-supply configurations. The power-supply voltage must be greater than 9 V (± 4.5 V) and less than 36 V (± 18 V).

7 Application and Implementation

注

Information in the following applications sections is not part of the TI component specification, and TI does not warrant its accuracy or completeness. TI's customers are responsible for determining suitability of components for their purposes, as well as validating and testing their design implementation to confirm system functionality.

7.1 Application Information

7.1.1 Driving a Capacitive Load

The OPAx892 are internally compensated to maximize bandwidth and slew-rate performance. To maintain stability, take additional precautions when driving capacitive loads with a high-performance amplifier. As a result of the internal compensation, significant capacitive loading directly on the output node decreases the device phase margin, and potentially lead to high-frequency ringing or oscillations. Therefore, for capacitive loads greater than 10 pF, place an isolation resistor in series with the output of the amplifier. [Figure 7-1](#) shows this configuration. For most applications, a minimum resistance of 20 Ω is recommended. In 75-Ω transmission systems, setting the series resistor value to 75 Ω is a beneficial choice because this value isolates any capacitance loading and provides source impedance matching.

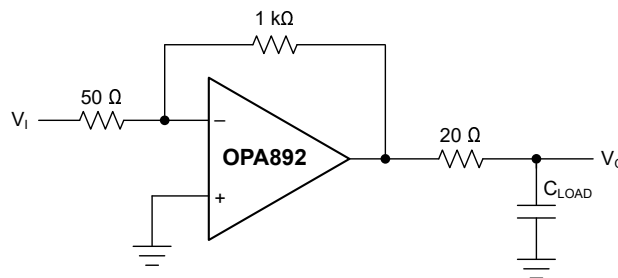

Figure 7-1. Driving a Capacitive Load

7.1.2 General Configuration

When receiving low-level signals, limiting the bandwidth of the incoming signals into the system is often required. [Figure 7-2](#) shows how the simplest way to accomplish this limiting is to place an RC filter at the noninverting pin of the amplifier.

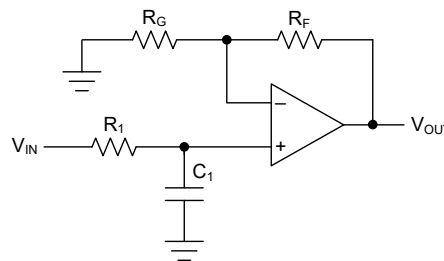

Figure 7-2. Single-Pole Low-Pass Filter

$$\frac{V_{OUT}}{V_{IN}} = \left(1 + \frac{R_F}{R_G}\right) \times \left(\frac{1}{1 + sR_1C_1}\right) \quad (1)$$

7.2 Typical Application

One important characteristic of the OPAx892 amplifier is the decompensated architecture. By pushing out the dominate pole to a higher frequency using this common technique, the amplifier is no longer stable in lower gain configurations. The minimum stable gain for the OPAx892 is specified to be 10 V/V. When a lower gain is needed in a preamp or buffer application, a related product to be considered is the [OPA891](#). Because the [OPA891](#) is not decompensated, the gain-bandwidth product is approximately an order of magnitude lower than the OPAx892. Both of these amplifiers have similar noise performance, but the best bandwidth and distortion performance comes from using the correct amplifier depending on the gain needs of the application.

When applications require gain of 10 V/V or larger, choose the OPAx892 to obtain a low value of harmonic distortion and THD+N. [Figure 7-3](#) shows a where in the analog signal chain this type of amplification can be required. Often found in applications such as ultrasound, audio, and sonar, a preamp is used near the input sensor to boost the signal to a more practical level with an emphasis on keeping noise and distortion as small as possible. Later in the signal chain, significantly more gain can be required to provide for other required functions such as analog filtering, mixing, splitting, or just the need to match the signal level to a following device. An amplifier such as the OPAx892 maintains the fidelity of the signal by providing the needed gain with significantly impacting distortion over a wide bandwidth and output swing. [Figure 7-4](#) shows the amplifier design example. The amplification stage provides an additional 10 V/V of gain to the analog signal chain.

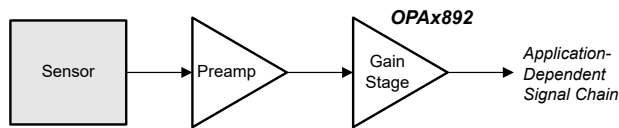

Figure 7-3. Gain Stage in an Analog-Front-End Block Diagram

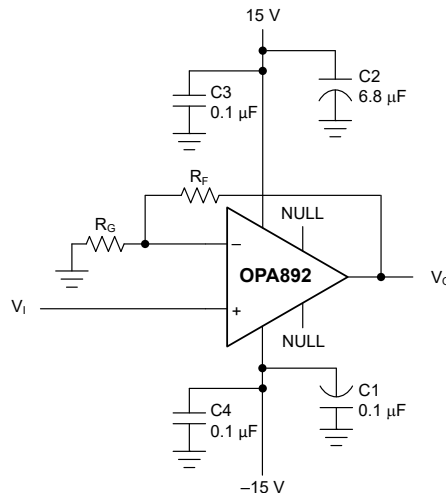

Figure 7-4. Noninverting Gain Configuration

7.2.1 Design Requirements

The objective is to design a 10 V/V amplifier to be for a mid-stage amplifier that minimizes the THD of the signal over the output range shown in [Table 7-1](#).

Table 7-1. Design Parameters

| PARAMETER | VALUE |
|----------------------|---------|
| Supply voltage | ±15 V |
| Voltage gain | +10 V/V |
| Small-signal peaking | < 2 dB |
| Load resistance | 1 kΩ |

7.2.2 Detailed Design Procedure

As detailed by [Figure 7-4](#), the example design is a common non-inverting op-amp configuration. In this design example, the split ± 15 V supplies are bypassed by a pair of capacitors as discussed in [Section 7.4.1](#). Although not explicitly shown, an optional resistor equal to $R_F \parallel R_G$ can be added from the noninverting input to ground to keep the inputs balanced to help mitigate input bias current impact.

Set the gain to 10 V/V by the proper selection of the two resistors using [Equation 2](#). In this example, set the ratio of the resistance to 9 to obtain the design goal of a gain of 10. There exists a second degree of freedom that allows the absolute value to be somewhat arbitrary while maintaining the specified ratio of resistor values. Increasing feedback resistance leads to an increase in the amount of overshoot in the small-signal frequency response (see [Figure 5-1](#)). In the time domain, the impact shows up as an increase in ringing and settling time for step-function input signals. If the resistances are very small, power dissipation effects increase.

$$\text{gain} = \frac{V_O}{V_I} = 1 + \frac{R_F}{R_G} \quad (2)$$

The best practice is to choose the resistors to be in of moderate values to avoid the detrimental effects at both extremes. Choosing $R_F = 220 \Omega$ is a good compromise in between these two extremes. Using [Equation 2](#), the corresponding gain resistor is found to be 24Ω . The amount of small-signal peaking is a modest 1.5 dB (see [Figure 5-1](#)), which meets the design goal.

A unique feature of this amplifier family is the output stage has been designed to drive a substantial amount of output current. This choice allows for the OPAx892 to maintain significant bandwidth even with very large input signals. [Figure 7-5](#) shows the modest reduction of bandwidth, even for output signals as large as $20 V_{PP}$. The time domain impact of this feature is a more precise amplification (that is, lower distortion) even for large dynamic range input signals.

Using the amplifier designed in this section, [Figure 7-6](#) shows the measured components of THD down to the 5th harmonic. The figure shows that the 2nd harmonic dictates the THD performance, with the 4th harmonic being the next highest component. Other amplifiers can produce low distortion at lower input levels but distortion rapidly rises as the output amplitude rises. [Figure 5-17](#) shows the harmonic distortion stays approximately constant, even at large values of output amplitude, making the OPAx892 a solid choice for large amplitude applications where distortion and noise are critical considerations.

7.2.3 Application Curves

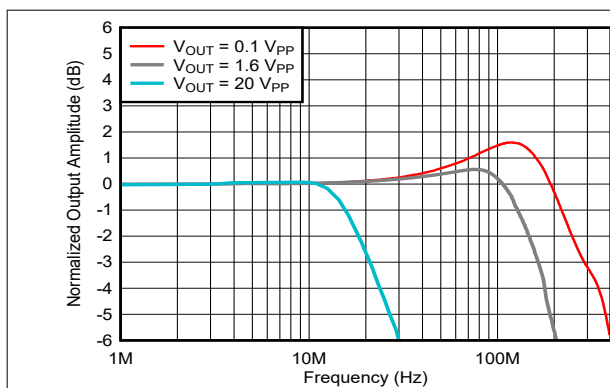

Figure 7-5. Very Large-Signal Frequency Response

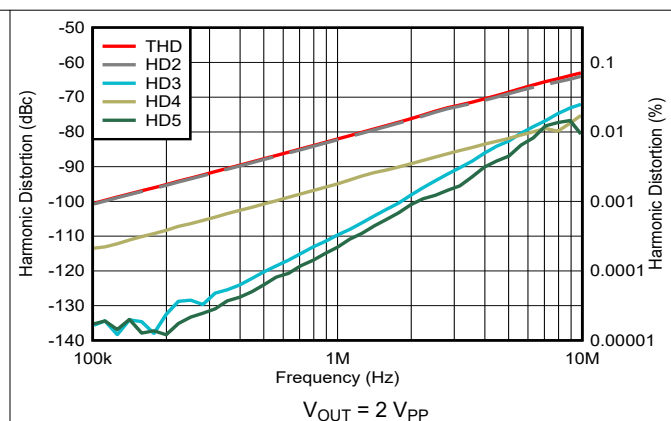

Figure 7-6. Harmonic Distortion Components vs Frequency

7.3 Power Supply Recommendations

The OPAx892 devices are designed to operate on power supplies ranging from ± 4.5 V to ± 16 V (single-ended supplies of 9 V to 32 V). Use a power-supply accuracy of 5% or better. When operated on a board with high-speed digital signals, provide isolation between digital signal noise and the analog input pins. The OPAx892 are connected to the positive power supply (V_{CC+}) through pin 7 and pin 8, respectively. Both devices use pin 4 for the negative power supply (V_{CC-}). Decouple each supply pin to GND as close to the device as possible.

7.4 Layout

7.4.1 Layout Guidelines

To achieve the levels of high-frequency performance of the OPAx892, follow proper printed-circuit board (PCB), high-frequency design techniques. The following is a general set of guidelines. In addition, a OPAx892 evaluation board is available to use as a guide for layout or for evaluating the device performance.

- **Ground planes**—ensure that the ground plane used on the board provides all components with a low-inductive ground connection. However, in the areas of the amplifier inputs and output, the ground plane can be removed to minimize stray capacitance.
- **Proper power-supply decoupling**—use a 6.8- μ F tantalum capacitor in parallel with a 0.1- μ F ceramic capacitor on each supply pin. Sharing the tantalum capacitor among several amplifiers is possible depending on the application, but always use a 0.1- μ F ceramic capacitor on the supply pin of every amplifier. In addition, place the 0.1- μ F capacitor as close as possible to the supply pin. As this distance increases, the inductance in the connecting trace makes the capacitor less effective. Strive for distances of less than 0.1 inch (2.54 mm) between the device power pins and the ceramic capacitors.
- **Short trace runs or compact part placements**—optimized high-frequency performance is achieved when stray series inductance has been minimized. To realize this, make the circuit layout as compact as possible, thereby minimizing the length of all trace runs. Pay particular attention to the inputs of the amplifier, keeping the trace lengths as short as possible. This layout helps to minimize stray capacitance at the input of the amplifier.

7.4.1.1 General PowerPAD™ Integrated Circuit Package Design Considerations

The OPAx892 is available in a thermally-enhanced DGN package, which is a member of the PowerPAD™ integrated circuit package family. [Figure 7-7 a](#) and [Figure 7-7 b](#) show that this package is constructed using a downset leadframe upon which the die is mounted. [Figure 7-7 c](#) that this arrangement results in the leadframe being exposed as a thermal pad on the underside of the package. Because this thermal pad has direct thermal contact with the die, excellent thermal performance can be achieved by providing a good thermal path away from the thermal pad.

The PowerPAD integrated circuit package allows for both assembly and thermal management in one manufacturing operation. During the surface-mount solder operation (when the leads are being soldered), the thermal pad can also be soldered to a copper area underneath the package. Through the use of thermal paths within this copper area, heat can be conducted away from the package into either a ground plane or other heat dissipating device.

The PowerPAD integrated circuit package represents a breakthrough in combining the small area and ease of assembly of the surface mount with the previously awkward mechanical methods of heat sinking.

More complete details of the PowerPAD integrated circuit package installation process and thermal management techniques are found in [PowerPAD Thermally-Enhanced Package](#). This document is found on the TI website (www.ti.com) by searching on the keyword PowerPAD. The document can also be ordered through your local TI sales office; refer to SLMA002 when ordering.

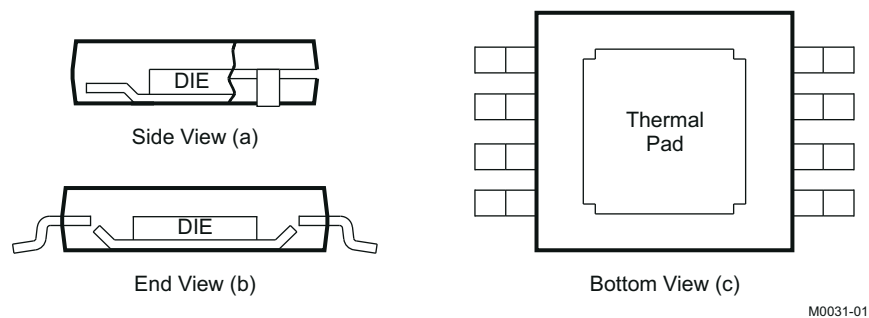

NOTE: The thermal pad (PowerPAD integrated circuit package) is electrically isolated from all other pins and can be connected to any potential from V_{CC-} to V_{CC+} . Typically, the thermal pad is connected to the ground plane because this plane tends to physically be the largest and is able to dissipate the most amount of heat.

Figure 7-7. Views of Thermally-Enhanced DGN Package

7.4.2 Layout Example

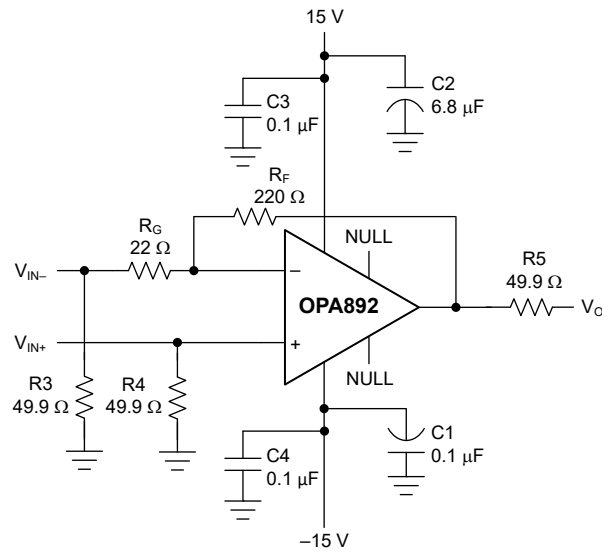

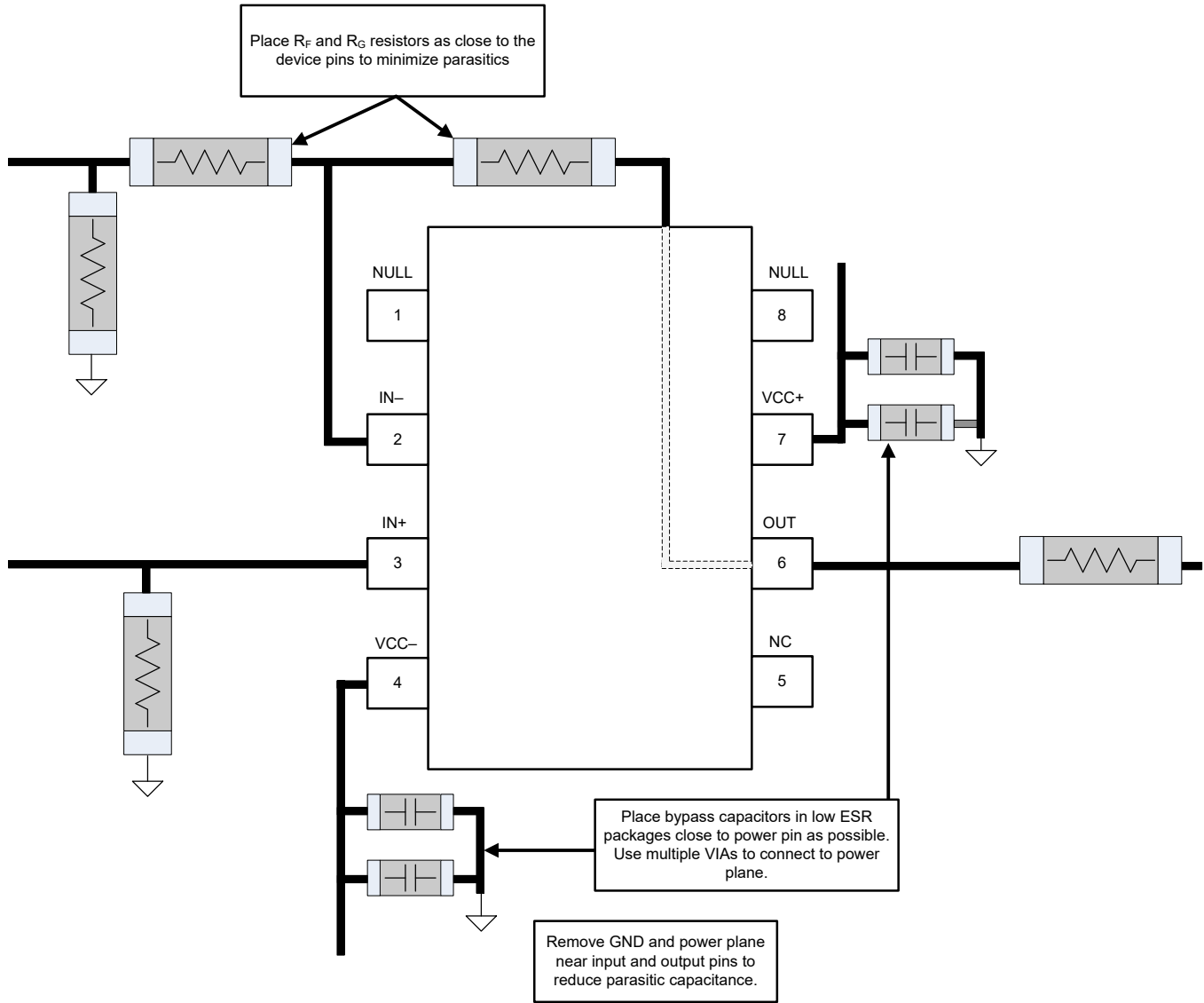

☒ 7-8. Layout Recommendations

8 Device and Documentation Support

TI offers an extensive line of development tools. Tools and software to evaluate the performance of the device, generate code, and develop solutions are listed below.

8.1 Documentation Support

8.1.1 Related Documentation

For related documentation, see the following:

- Texas Instruments, [Noise Analysis in Operational Amplifier Circuits application report](#)
- Texas Instruments, [PowerPAD Thermally Enhanced Package application report](#)
- Texas Instruments, [Single op-amp evaluation module for SO-8 package users guide](#)
- Texas Instruments, [Dual op-amp evaluation module for SO-8 package users guide](#)
- Texas Instruments, [Dual op amp evaluation module for MSOP-8 package users guide](#)

8.2 ドキュメントの更新通知を受け取る方法

ドキュメントの更新についての通知を受け取るには、www.tij.co.jp のデバイス製品フォルダを開いてください。[通知] をクリックして登録すると、変更されたすべての製品情報に関するダイジェストを毎週受け取ることができます。変更の詳細については、改訂されたドキュメントに含まれている改訂履歴をご覧ください。

8.3 サポート・リソース

テキサス・インスツルメンツ E2E™ サポート・フォーラムは、エンジニアが検証済みの回答と設計に関するヒントをエキスパートから迅速かつ直接得ることができる場所です。既存の回答を検索したり、独自の質問をしたりすることで、設計に必要な支援を迅速に得ることができます。

リンクされているコンテンツは、各寄稿者により「現状のまま」提供されるものです。これらはテキサス・インスツルメンツの仕様を構成するものではなく、必ずしもテキサス・インスツルメンツの見解を反映したものではありません。テキサス・インスツルメンツの[使用条件](#)を参照してください。

8.4 Trademarks

PowerPAD™ and テキサス・インスツルメンツ E2E™ are trademarks of Texas Instruments.

すべての商標は、それぞれの所有者に帰属します。

8.5 静電気放電に関する注意事項



この IC は、ESD によって破損する可能性があります。テキサス・インスツルメンツは、IC を取り扱う際には常に適切な注意を払うことを推奨します。正しい取り扱いおよび設置手順に従わない場合、デバイスを破損するおそれがあります。

ESD による破損は、わずかな性能低下からデバイスの完全な故障まで多岐にわたります。精密な IC の場合、パラメータがわずかに変化するだけで公表されている仕様から外れる可能性があるため、破損が発生しやすくなっています。

8.6 用語集

[テキサス・インスツルメンツ用語集](#) この用語集には、用語や略語の一覧および定義が記載されています。

9 Revision History

資料番号末尾の英字は改訂を表しています。その改訂履歴は英語版に準じています。

| Changes from Revision * (November 2023) to Revision A (July 2024) | Page |
|--|------|
| • OPA2892 のステータスを「事前情報」から「量産データ」(アクティブ)に変更..... | 1 |
| • Added thermal pad information to Table 4-2, <i>Pin Functions: OPA2892</i> | 3 |
| • Added missing unit for Supply current in <i>Electrical Characteristics</i> | 5 |
| • Added Figure 5-20, <i>OPA2892 Crosstalk vs Frequency</i> | 7 |

10 Mechanical, Packaging, and Orderable Information

The following pages include mechanical, packaging, and orderable information. This information is the most current data available for the designated devices. This data is subject to change without notice and revision of this document. For browser-based versions of this data sheet, refer to the left-hand navigation.

重要なお知らせと免責事項

テキサス・インスツルメンツは、技術データと信頼性データ (データシートを含みます)、設計リソース (リファレンス デザインを含みます)、アプリケーションや設計に関する各種アドバイス、Web ツール、安全性情報、その他のリソースを、欠陥が存在する可能性のある「現状のまま」提供しており、商品性および特定目的に対する適合性の黙示保証、第三者の知的財産権の非侵害保証を含むいかなる保証も、明示的または黙示的にかかわらず拒否します。

これらのリソースは、テキサス・インスツルメンツ製品を使用する設計の経験を積んだ開発者への提供を意図したものです。(1) お客様のアプリケーションに適した テキサス・インスツルメンツ製品の選定、(2) お客様のアプリケーションの設計、検証、試験、(3) お客様のアプリケーションに該当する各種規格や、その他のあらゆる安全性、セキュリティ、規制、または他の要件への確実な適合に関する責任を、お客様のみが単独で負うものとします。

上記の各種リソースは、予告なく変更される可能性があります。これらのリソースは、リソースで説明されている テキサス・インスツルメンツ製品を使用するアプリケーションの開発の目的でのみ、テキサス・インスツルメンツはその使用をお客様に許諾します。これらのリソースに関して、他の目的で複製することや掲載することは禁止されています。テキサス・インスツルメンツや第三者の知的財産権のライセンスが付与されている訳ではありません。お客様は、これらのリソースを自身で使用した結果発生するあらゆる申し立て、損害、費用、損失、責任について、テキサス・インスツルメンツおよびその代理人を完全に補償するものとし、テキサス・インスツルメンツは一切の責任を拒否します。

テキサス・インスツルメンツの製品は、[テキサス・インスツルメンツの販売条件](#)、または [ti.com](https://www.ti.com) やかかる テキサス・インスツルメンツ製品の関連資料などのいずれかを通じて提供する適用可能な条項の下で提供されています。テキサス・インスツルメンツがこれらのリソースを提供することは、適用されるテキサス・インスツルメンツの保証または他の保証の放棄の拡大や変更を意味するものではありません。

お客様がいかなる追加条項または代替条項を提案した場合でも、テキサス・インスツルメンツはそれらに異議を唱え、拒否します。

郵送先住所: Texas Instruments, Post Office Box 655303, Dallas, Texas 75265

Copyright © 2024, Texas Instruments Incorporated

PACKAGING INFORMATION

| Orderable Device | Status (1) | Package Type | Package Drawing | Pins | Package Qty | Eco Plan (2) | Lead finish/ Ball material (6) | MSL Peak Temp (3) | Op Temp (°C) | Device Marking (4/5) | Samples |
|------------------|---------------|--------------|-----------------|------|-------------|-----------------|--------------------------------------|----------------------|--------------|-------------------------|-------------------------|
| OPA2892DGNR | ACTIVE | HVSSOP | DGN | 8 | 3000 | RoHS & Green | NIPDAU | Level-2-260C-1 YEAR | -40 to 85 | 2892 | Samples |
| OPA892DR | ACTIVE | SOIC | D | 8 | 3000 | RoHS & Green | NIPDAU | Level-1-260C-UNLIM | -40 to 85 | O892 | Samples |

(1) The marketing status values are defined as follows:

ACTIVE: Product device recommended for new designs.

LIFEBUY: TI has announced that the device will be discontinued, and a lifetime-buy period is in effect.

NRND: Not recommended for new designs. Device is in production to support existing customers, but TI does not recommend using this part in a new design.

PREVIEW: Device has been announced but is not in production. Samples may or may not be available.

OBSOLETE: TI has discontinued the production of the device.

(2) **RoHS:** TI defines "RoHS" to mean semiconductor products that are compliant with the current EU RoHS requirements for all 10 RoHS substances, including the requirement that RoHS substance do not exceed 0.1% by weight in homogeneous materials. Where designed to be soldered at high temperatures, "RoHS" products are suitable for use in specified lead-free processes. TI may reference these types of products as "Pb-Free".

RoHS Exempt: TI defines "RoHS Exempt" to mean products that contain lead but are compliant with EU RoHS pursuant to a specific EU RoHS exemption.

Green: TI defines "Green" to mean the content of Chlorine (Cl) and Bromine (Br) based flame retardants meet JS709B low halogen requirements of <=1000ppm threshold. Antimony trioxide based flame retardants must also meet the <=1000ppm threshold requirement.

(3) MSL, Peak Temp. - The Moisture Sensitivity Level rating according to the JEDEC industry standard classifications, and peak solder temperature.

(4) There may be additional marking, which relates to the logo, the lot trace code information, or the environmental category on the device.

(5) Multiple Device Markings will be inside parentheses. Only one Device Marking contained in parentheses and separated by a "~" will appear on a device. If a line is indented then it is a continuation of the previous line and the two combined represent the entire Device Marking for that device.

(6) Lead finish/Ball material - Orderable Devices may have multiple material finish options. Finish options are separated by a vertical ruled line. Lead finish/Ball material values may wrap to two lines if the finish value exceeds the maximum column width.

Important Information and Disclaimer:The information provided on this page represents TI's knowledge and belief as of the date that it is provided. TI bases its knowledge and belief on information provided by third parties, and makes no representation or warranty as to the accuracy of such information. Efforts are underway to better integrate information from third parties. TI has taken and continues to take reasonable steps to provide representative and accurate information but may not have conducted destructive testing or chemical analysis on incoming materials and chemicals. TI and TI suppliers consider certain information to be proprietary, and thus CAS numbers and other limited information may not be available for release.

In no event shall TI's liability arising out of such information exceed the total purchase price of the TI part(s) at issue in this document sold by TI to Customer on an annual basis.

TAPE AND REEL INFORMATION

QUADRANT ASSIGNMENTS FOR PIN 1 ORIENTATION IN TAPE

*All dimensions are nominal

| Device | Package Type | Package Drawing | Pins | SPQ | Reel Diameter (mm) | Reel Width W1 (mm) | A0 (mm) | B0 (mm) | K0 (mm) | P1 (mm) | W (mm) | Pin1 Quadrant |
|-------------|--------------|-----------------|------|------|--------------------|--------------------|---------|---------|---------|---------|--------|---------------|
| OPA2892DGNR | HVSSOP | DGN | 8 | 3000 | 330.0 | 12.4 | 5.3 | 3.4 | 1.4 | 8.0 | 12.0 | Q1 |
| OPA892DR | SOIC | D | 8 | 3000 | 330.0 | 12.4 | 6.4 | 5.2 | 2.1 | 8.0 | 12.0 | Q1 |

TAPE AND REEL BOX DIMENSIONS

*All dimensions are nominal

| Device | Package Type | Package Drawing | Pins | SPQ | Length (mm) | Width (mm) | Height (mm) |
|-------------|--------------|-----------------|------|------|-------------|------------|-------------|
| OPA2892DGNR | HVSSOP | DGN | 8 | 3000 | 353.0 | 353.0 | 32.0 |
| OPA892DR | SOIC | D | 8 | 3000 | 356.0 | 356.0 | 35.0 |

GENERIC PACKAGE VIEW

DGN 8

PowerPAD VSSOP - 1.1 mm max height

3 x 3, 0.65 mm pitch

SMALL OUTLINE PACKAGE

This image is a representation of the package family, actual package may vary.
Refer to the product data sheet for package details.

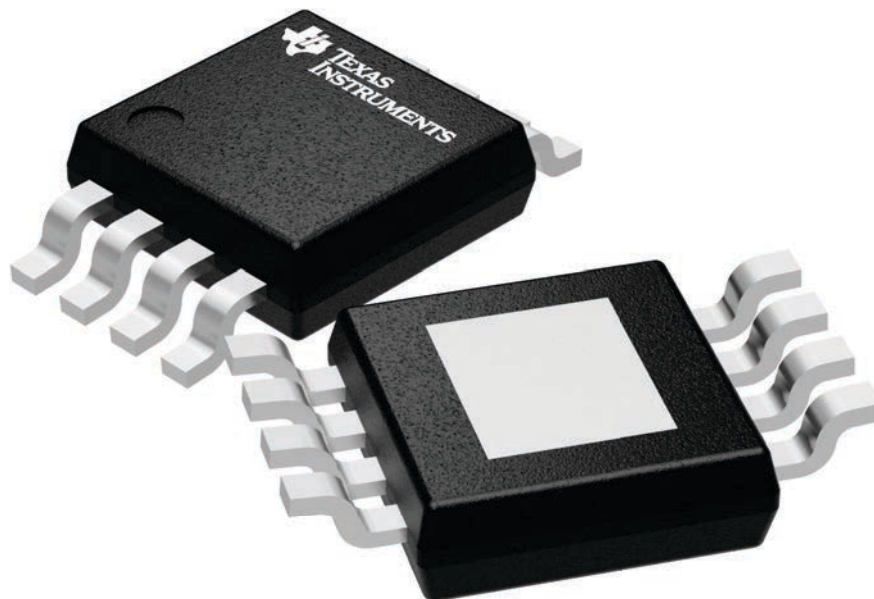

4225482/A

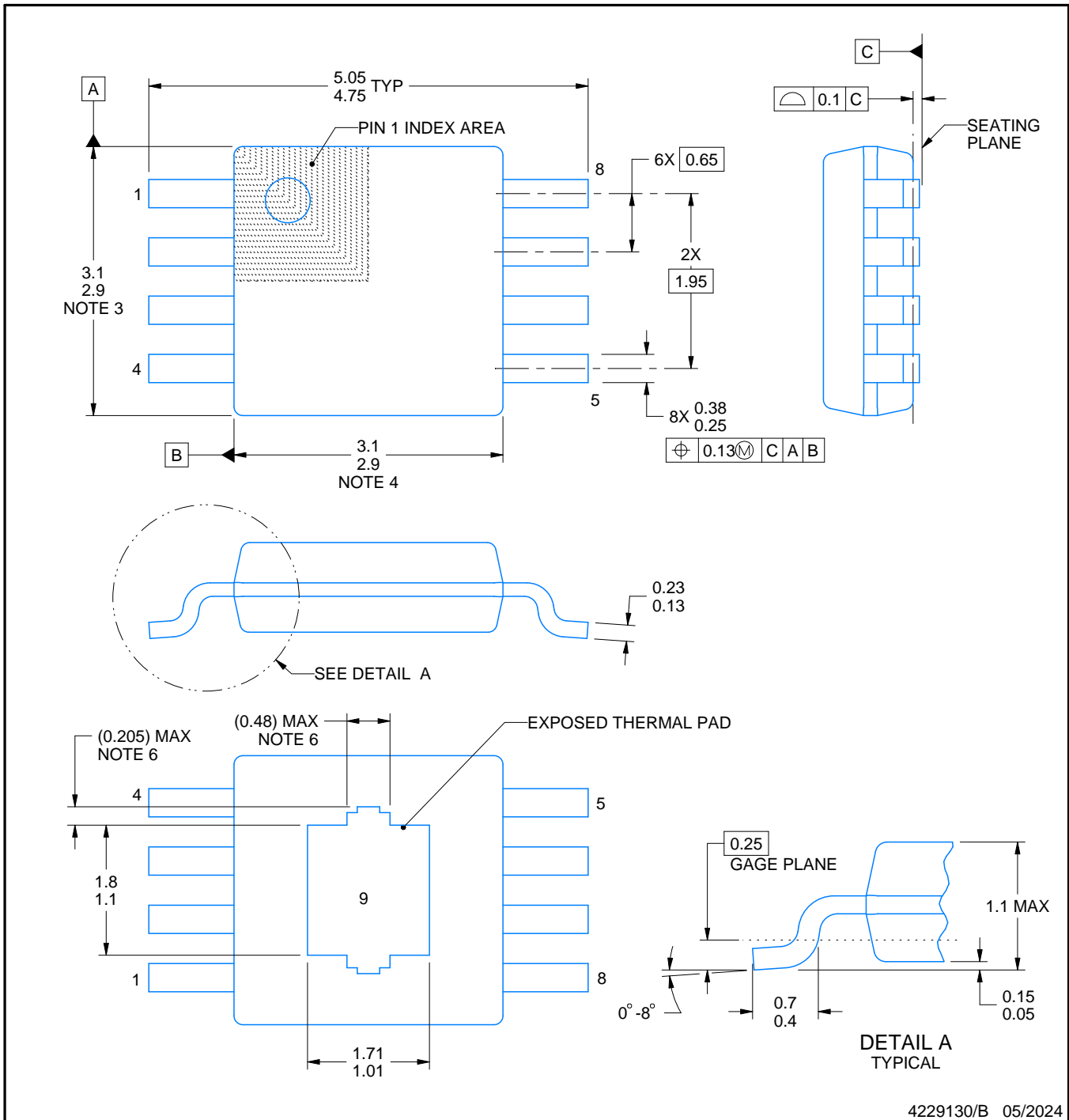
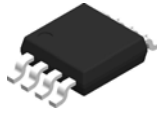

4229130/B 05/2024

NOTES:

PowerPAD is a trademark of Texas Instruments.

1. All linear dimensions are in millimeters. Any dimensions in parenthesis are for reference only. Dimensioning and tolerancing per ASME Y14.5M.
2. This drawing is subject to change without notice.
3. This dimension does not include mold flash, protrusions, or gate burrs. Mold flash, protrusions, or gate burrs shall not exceed 0.15 mm per side.
4. This dimension does not include interlead flash. Interlead flash shall not exceed 0.25 mm per side.
5. Reference JEDEC registration MO-187.
6. Features may differ or may not be present.

EXAMPLE BOARD LAYOUT

DGN0008H

PowerPAD™ VSSOP - 1.1 mm max height

SMALL OUTLINE PACKAGE

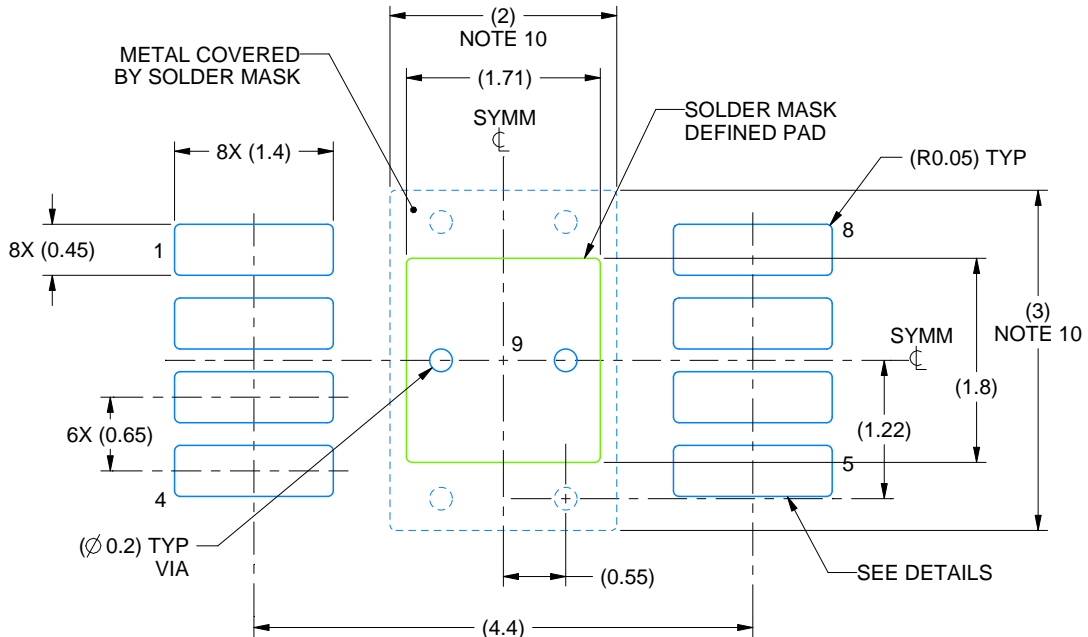

LAND PATTERN EXAMPLE
EXPOSED METAL SHOWN
SCALE: 15X

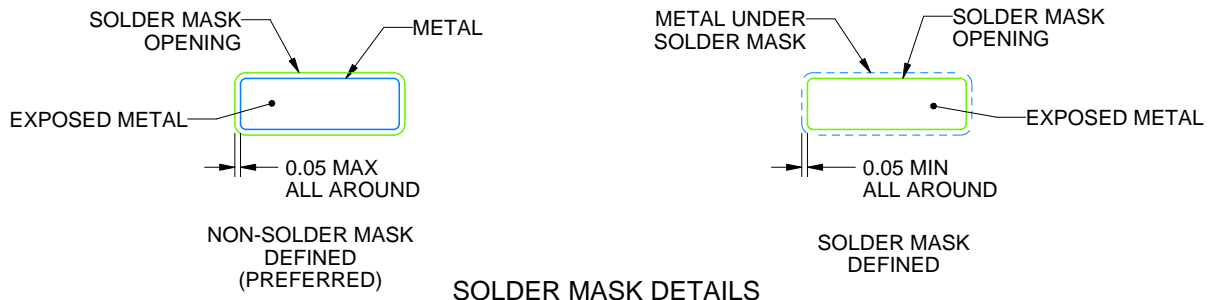

SOLDER MASK DETAILS

4229130/B 05/2024

NOTES: (continued)

7. Publication IPC-7351 may have alternate designs.
8. Solder mask tolerances between and around signal pads can vary based on board fabrication site.
9. Vias are optional depending on application, refer to device data sheet. If any vias are implemented, refer to their locations shown on this view. It is recommended that vias under paste be filled, plugged or tented.
10. Size of metal pad may vary due to creepage requirement.

EXAMPLE STENCIL DESIGN

DGN0008H

PowerPAD™ VSSOP - 1.1 mm max height

SMALL OUTLINE PACKAGE

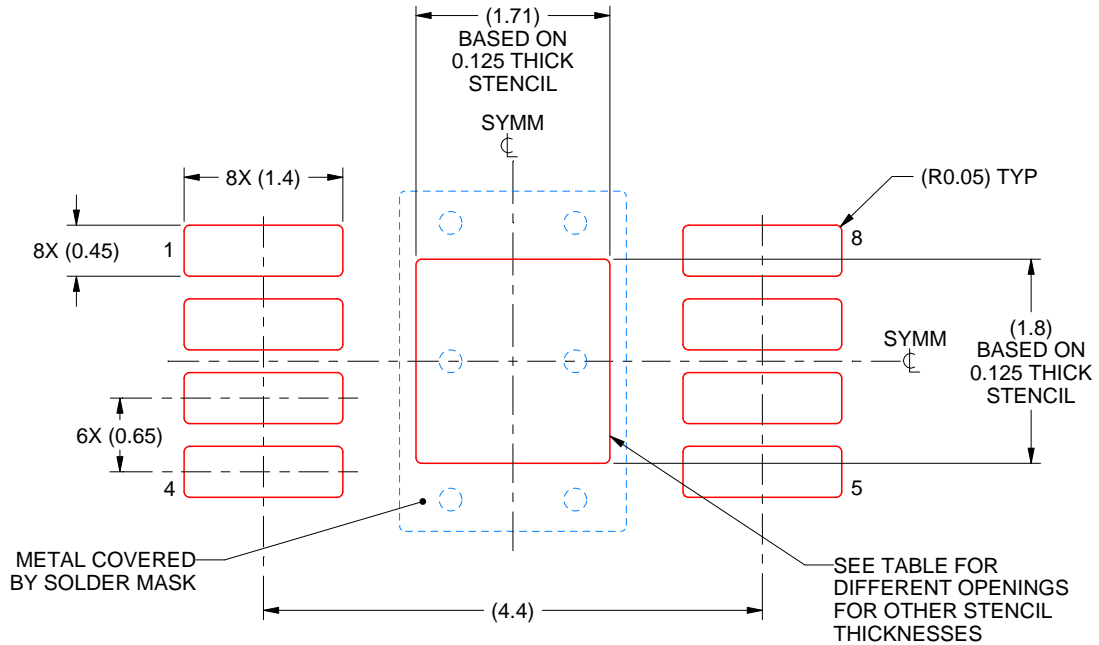

SOLDER PASTE EXAMPLE
 EXPOSED PAD 9:
 100% PRINTED SOLDER COVERAGE BY AREA
 SCALE: 15X

| STENCIL THICKNESS | SOLDER STENCIL OPENING |
|-------------------|------------------------|
| 0.1 | 1.91 X 2.01 |
| 0.125 | 1.71 X 1.80 (SHOWN) |
| 0.15 | 1.56 X 1.64 |
| 0.175 | 1.45 X 1.52 |

4229130/B 05/2024

NOTES: (continued)

11. Laser cutting apertures with trapezoidal walls and rounded corners may offer better paste release. IPC-7525 may have alternate design recommendations.
12. Board assembly site may have different recommendations for stencil design.



D0008A

PACKAGE OUTLINE

SOIC - 1.75 mm max height

SMALL OUTLINE INTEGRATED CIRCUIT



4214825/C 02/2019

NOTES:

1. Linear dimensions are in inches [millimeters]. Dimensions in parenthesis are for reference only. Controlling dimensions are in inches. Dimensioning and tolerancing per ASME Y14.5M.
2. This drawing is subject to change without notice.
3. This dimension does not include mold flash, protrusions, or gate burrs. Mold flash, protrusions, or gate burrs shall not exceed $.006$ [0.15] per side.
4. This dimension does not include interlead flash.
5. Reference JEDEC registration MS-012, variation AA.

EXAMPLE BOARD LAYOUT

D0008A

SOIC - 1.75 mm max height

SMALL OUTLINE INTEGRATED CIRCUIT



LAND PATTERN EXAMPLE
 EXPOSED METAL SHOWN
 SCALE:8X



SOLDER MASK DETAILS

4214825/C 02/2019

NOTES: (continued)

- 6. Publication IPC-7351 may have alternate designs.
- 7. Solder mask tolerances between and around signal pads can vary based on board fabrication site.

EXAMPLE STENCIL DESIGN

D0008A

SOIC - 1.75 mm max height

SMALL OUTLINE INTEGRATED CIRCUIT

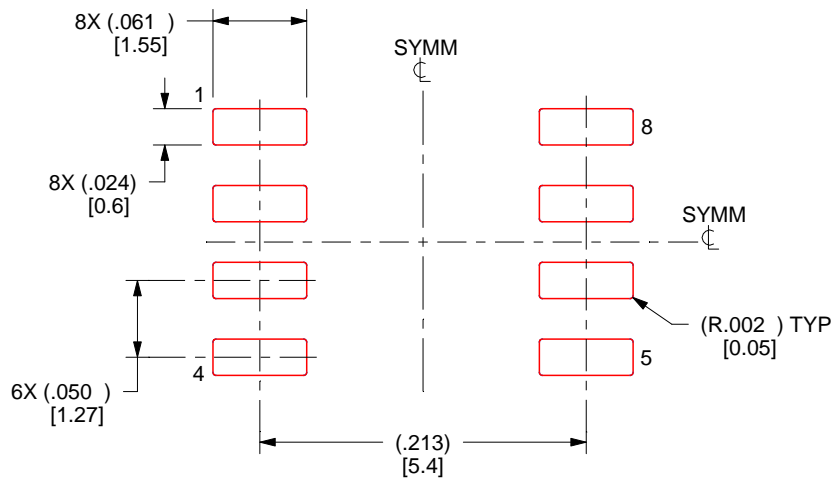

SOLDER PASTE EXAMPLE
BASED ON .005 INCH [0.125 MM] THICK STENCIL
SCALE:8X

4214825/C 02/2019

NOTES: (continued)

8. Laser cutting apertures with trapezoidal walls and rounded corners may offer better paste release. IPC-7525 may have alternate design recommendations.
9. Board assembly site may have different recommendations for stencil design.

重要なお知らせと免責事項

TI は、技術データと信頼性データ(データシートを含みます)、設計リソース(リファレンス・デザインを含みます)、アプリケーションや設計に関する各種アドバイス、Web ツール、安全性情報、その他のリソースを、欠陥が存在する可能性のある「現状のまま」提供しており、商品性および特定目的に対する適合性の黙示保証、第三者の知的財産権の非侵害保証を含むいかなる保証も、明示的または黙示的にかかわらず拒否します。

これらのリソースは、TI 製品を使用する設計の経験を積んだ開発者への提供を意図したものです。(1) お客様のアプリケーションに適した TI 製品の選定、(2) お客様のアプリケーションの設計、検証、試験、(3) お客様のアプリケーションに該当する各種規格や、その他のあらゆる安全性、セキュリティ、規制、または他の要件への確実な適合に関する責任を、お客様のみが単独で負うものとします。

上記の各種リソースは、予告なく変更される可能性があります。これらのリソースは、リソースで説明されている TI 製品を使用するアプリケーションの開発の目的でのみ、TI はその使用をお客様に許諾します。これらのリソースに関して、他の目的で複製することや掲載することは禁止されています。TI や第三者の知的財産権のライセンスが付与されている訳ではありません。お客様は、これらのリソースを自身で使用した結果発生するあらゆる申し立て、損害、費用、損失、責任について、TI およびその代理人を完全に補償するものとし、TI は一切の責任を拒否します。

TI の製品は、[TI の販売条件](#)、または [ti.com](#) やかかる TI 製品の関連資料などのいずれかを通じて提供する適用可能な条項の下で提供されています。TI がこれらのリソースを提供することは、適用される TI の保証または他の保証の放棄の拡大や変更を意味するものではありません。

お客様がいかなる追加条項または代替条項を提案した場合でも、TI はそれらに異議を唱え、拒否します。

郵送先住所 : Texas Instruments, Post Office Box 655303, Dallas, Texas 75265
Copyright © 2024, Texas Instruments Incorporated