

# TMP110 低コスト システム向け、超小型、 $\pm 1.0^{\circ}\text{C}$ 精度、 $I^2\text{C}$ デジタル温度センサ

## 1 特長

- 超小型、リードレス X2SON-5 パッケージ
  - パッケージ サイズ:  $0.8 \times 0.8 \times 0.4\text{mm}$
- 広い動作範囲
  - V+ 動作範囲:  $1.14\text{V} \sim 5.5\text{V}$
  - 温度範囲:  $-40^{\circ}\text{C} \sim 125^{\circ}\text{C}$
- 動作温度全域で精度を確保
  - $-40^{\circ}\text{C} \sim 125^{\circ}\text{C}$ で  $\pm 1.0^{\circ}\text{C}$  (最大値)
- 12 ビット分解能:  $0.0625^{\circ}\text{C}$  (LSB)
- 柔軟なデジタル インターフェイス
  - $I^2\text{C}$  バスおよび SMBus 互換
  - I3C 混在バス上での共存に対応
- ピン配置とソフトウェアの互換性があるアップグレード
  - $\pm 0.5^{\circ}\text{C} \rightarrow$  **TMP112** (X2SON パッケージ)
- 低い電源電流
  - アクティブ電流:  $55\mu\text{A}$  (標準値)
  - シャットダウン電流:  $0.15\mu\text{A}$  (標準値)
  - 平均電流 (1Hz 時):  $3.2\mu\text{A}$  (標準値)
- 業界標準とソフトウェア互換
  - TMP102**, **TMP112**
- 2 種類のピン配置を選択可能
  - ALERT ピン: **TMP110D0**, **TMP110D1**, **TMP110D2**, **TMP110D3**
  - アドレスピン: **TMP110D**
- GUI ベースの C コード ジェネレータ

## 2 アプリケーション

- ビル オートメーション
  - 物体検出
  - ビデオドアベル
  - HVAC: ワイヤレス環境センサ
- ファクトリ オートメーション & 制御
  - マシンビジョン カメラ
  - 産業用 PC: シングル ボード コンピュータ
  - CPU (PLC コントローラ)
- コールド チェーン
- データ センター & エンタープライズ コンピューティング
  - ソリッド ステートドライブ (SSD)
  - ラック サーバー向けマザーボード
- パーソナル エレクトロニクス
  - PC & ノート PC、タブレット
  - デジタル スチル カメラ & デジタル ビデオ カメラ
  - 拡張現実 (AR) メガネ

– スマートスピーカー

## 3 概要

TMP110 は、超小型 ( $0.64\text{mm}^2$ ) 5 ピン パッケージの  $I^2\text{C}$  互換デジタル温度センサです。その小型低背パッケージは、DSBGA パッケージでは適さないような容積に制約のあるシステムに最適化されています。同等サイズの DSBGA パッケージとは異なり、TMP110 は、アドレスピンと ALERT ピンのどちらとしても使用できる第 5 のピンを持っているため、センサの数を拡張することにも、重要な熱イベントを監視することにも柔軟に対応できます。

TMP110 は、温度分解能  $0.0625^{\circ}\text{C}$  の内蔵 12 ビット A/D コンバータ (ADC) により、動作温度の全域で  $\pm 1.0^{\circ}\text{C}$  の精度を達成しています。

TMP110 は最小  $1.14\text{V}$  の電源電圧で動作するように設計されています。平均電流、シャットダウン電流はそれぞれ  $3.2\mu\text{A}$  (1Hz 時)、 $0.15\mu\text{A}$  と小さいため、オンデマンドの温度変換が可能であり、バッテリー寿命を最大化できます。また、各種産業用アプリケーション向けに、電源電圧を最大  $5.5\text{V}$  まで上げることができます。

### パッケージ情報

部品番号	パッケージ <sup>1</sup>	パッケージ サイズ <sup>2</sup>
TMP110	X2SON (5)	$0.8\text{mm} \times 0.8\text{mm}$

- 詳細については、[セクション 12](#) を参照してください。
- パッケージ サイズ (長さ  $\times$  幅) は公称値であり、該当する場合はピンも含まれます。



図 3-1. 概略回路図



## Table of Contents

<b>1 特長</b> .....	1	8.1 Temp_Result Register (address = 00h) [reset = xxxxh].....	23
<b>2 アプリケーション</b> .....	1	8.2 Configuration Register (address = 01h) [reset = 60A0h].....	24
<b>3 概要</b> .....	1	8.3 TLow_Limit Register (address = 02h) [reset = 4B00h].....	25
<b>4 Related Products</b> .....	3	8.4 THigh_Limit Register (address = 03h) [reset = 5000h].....	26
<b>5 Pin Configuration and Functions</b> .....	3	<b>9 Application and Implementation</b> .....	27
<b>6 Specifications</b> .....	4	9.1 Application Information.....	27
6.1 Absolute Maximum Ratings.....	4	9.2 Equal I <sup>2</sup> C Pullup and Supply Application.....	27
6.2 ESD Ratings.....	4	9.3 Layout.....	29
6.3 Recommended Operating Conditions.....	4	<b>10 Device and Documentation Support</b> .....	31
6.4 Thermal Information.....	4	10.1 Documentation Support.....	31
6.5 Electrical Characteristics.....	5	10.2 ドキュメントの更新通知を受け取る方法.....	31
6.6 I <sup>2</sup> C Interface Timing.....	7	10.3 サポート・リソース.....	31
6.7 Timing Diagrams.....	7	10.4 Trademarks.....	31
6.8 Typical Characteristics.....	8	10.5 静電気放電に関する注意事項.....	31
<b>7 Detailed Description</b> .....	11	10.6 用語集.....	31
7.1 Overview.....	11	<b>11 Revision History</b> .....	31
7.2 Functional Block Diagram.....	11	<b>12 メカニカル、パッケージ、および注文情報</b> .....	32
7.3 Feature Description.....	11		
7.4 Device Functional Modes.....	16		
7.5 Programming.....	17		
<b>8 Register Map</b> .....	22		

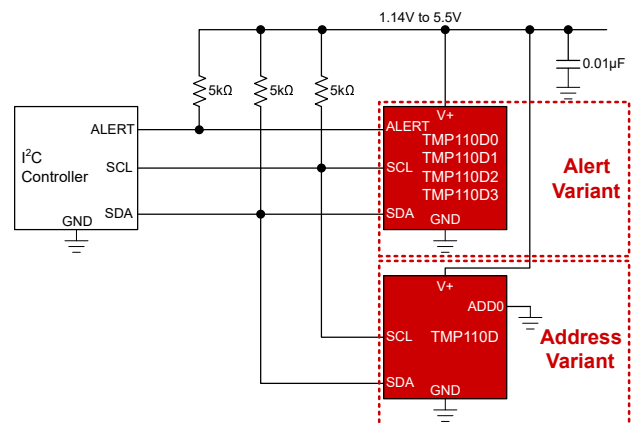
## 4 Related Products

Pin-to-pin and software compatible options are available.

表 4-1. Related Temperature Sensors

DEVICE	BEST ACCURACY (MAXIMUM)	SOFTWARE COMPATIBLE	ADDRESS/ALERT PIN FUNCTIONALITY	PACKAGE OPTIONS
TMP102	2.0 °C	Yes	Address + Alert	DRL (6-pin SOT563) (1.6mm × 1.6mm)
TMP110	1.0 °C	Yes	Separate (Address & Alert)	DPW (5-pin X2SON) (0.8mm × 0.8mm)
TMP112	0.5 °C	Yes	Address + Alert (DRL)	DRL (6-pin SOT563) (1.6mm × 1.6mm)
			Separate (Address & Alert) (DPW)	DPW (5-pin X2SON) (0.8mm × 0.8mm)

## 5 Pin Configuration and Functions



図 5-1. DPW Package  
5-Pin X2SON  
Address variant  
(Top View)



図 5-2. DPW Package  
5-Pin X2SON  
Alert variant  
(Top View)

表 5-1. Pin Functions

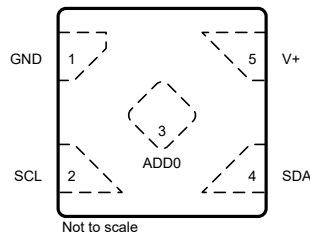
NAME	PIN		TYPE <sup>(1)</sup>	DESCRIPTION
	NO.	NO.		
GND	1	1	—	Ground <b>Pin-1 has curved edges.</b>
SCL	2	2	I	Serial clock
ADD0 (TMP110D)	3	—	I	Address select. Connect to GND, SCL, SDA or V+. <b>Only for Address variant.</b>
ALERT (TMP110D0, TMP110D1, TMP110D2, TMP110D3)	—	3	O	Overtemperature alert <sup>(2)</sup> . Open-drain output; requires a pullup resistor. <b>Only for Alert variant.</b> <b>Note:</b> Connecting to GND if Alert pin is not used is preferred.
SDA	4	4	I/O	Serial data input. Open-drain output; requires a pullup resistor.
V+	5	5	I	Supply voltage

(1) I = Input, O = Output, I/O = Input or Output.

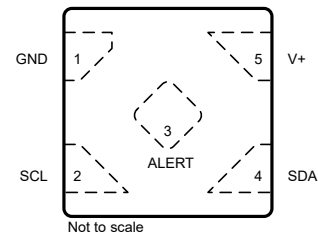
(2) For more information see [セクション 7.3.3](#)

## 6 Specifications

### 6.1 Absolute Maximum Ratings

Over free-air temperature range unless otherwise noted<sup>(1)</sup>

		MIN	MAX	UNIT
Supply voltage	V+	-0.3	6	V
Input/Output voltage	SCL, SDA, ADD0, ALERT	-0.3	6	V
Output current			±10	mA
Operating temperature, T <sub>A</sub>		-40	125	°C
Junction temperature, T <sub>J</sub>			150	°C
Storage temperature, T <sub>stg</sub>		-55	150	°C

- (1) Operation outside the *Absolute Maximum Ratings* may cause permanent device damage. *Absolute Maximum Ratings* do not imply functional operation of the device at these or any other conditions beyond those listed under *Recommended Operating Conditions*. If used outside the *Recommended Operating Conditions* but within the *Absolute Maximum Ratings*, the device may not be fully functional, and this may affect device reliability, functionality, performance, and shorten the device lifetime.

### 6.2 ESD Ratings

			VALUE	UNIT
V <sub>(ESD)</sub>	Electrostatic discharge	Human-body model (HBM), per ANSI/ESDA/JEDEC JS-001 <sup>(1)</sup>	±2000	V
		Charged-device model (CDM), per JEDEC specification JESD22-C101 <sup>(2)</sup>	±1000	

- (1) JEDEC document JEP155 states that 500V HBM allows safe manufacturing with a standard ESD control process.  
(2) JEDEC document JEP157 states that 250V CDM allows safe manufacturing with a standard ESD control process.

### 6.3 Recommended Operating Conditions

		MIN	NOM	MAX	UNIT
V+	Supply voltage	1.14	3.3	5.5	V
V <sub>I/O</sub>	SCL, SDA, ADD0, ALERT	0		5.5	V
I <sub>OL</sub>	SDA, ALERT	0		3	mA
T <sub>A</sub>	Operating ambient temperature	-40		125	°C

### 6.4 Thermal Information

THERMAL METRIC <sup>(1)</sup>		TMP110	UNIT
		DPW	
		5-pins	
R <sub>θJA</sub>	Junction-to-ambient thermal resistance	230	°C/W
R <sub>θJC(top)</sub>	Junction-to-case (top) thermal resistance	194	°C/W
R <sub>θJB</sub>	Junction-to-board thermal resistance	158.4	°C/W
Ψ <sub>JT</sub>	Junction-to-top characterization parameter	20	°C/W
Ψ <sub>JB</sub>	Junction-to-board characterization parameter	158.3	°C/W
R <sub>θJC(bot)</sub>	Junction-to-case (bottom) thermal resistance	108.4	°C/W
M <sub>T</sub>	Thermal Mass	0.46	mJ/°C

- (1) For more information about traditional and new thermal metrics, see the [Semiconductor and IC Package Thermal Metrics application note](#).

## 6.5 Electrical Characteristics

Over free-air temperature range and  $V+ = 1.14V$  to  $5.5V$  (unless otherwise noted); Typical specifications are at  $T_A = 25^\circ C$  and  $V+ = 3.3V$  (unless otherwise noted)

PARAMETER		TEST CONDITIONS		MIN	TYP	MAX	UNIT
<b>TEMPERATURE SENSOR</b>							
$T_{ERR}$	Accuracy (temperature error)	$-40^\circ C$ to $125^\circ C$	$1.14V \leq V+ \leq 1.4V$			$\pm 2.0$	$^\circ C$
			$1.4V < V+ \leq 5.5V$			$\pm 1.0$	$^\circ C$
PSR	DC power supply rejection	$V+ \geq 1.4V$			0.02		$^\circ C/V$
$T_{RES}$	Temperature resolution				12		Bits
					62.5		$m^\circ C$
$T_{REPEAT}$	Repeatability <sup>(1)</sup>	$V+ = 3.3V$ 3 sigma distribution			$\pm 1$		LSB
$T_{LTD}$	Long-term stability and drift	1000 hours at $125^\circ C$ <sup>(2)</sup>			$\pm 1$		LSB
$t_{RESP\_L}$	Response time (Stirred Liquid)	2-layer FR4 PCB 1.5748 mm thickness	$\tau = 63\%$ for step response from $25^\circ C$ to $75^\circ C$		1.45		s
$T_{HYST}$	Temperature cycling and hysteresis <sup>(3)</sup>				0.0625		$^\circ C$
$t_{ACT}$	Active conversion time	$V+ \geq 1.4V$			10.25	11.25	ms
		$V+ < 1.4V$			10.5	12	
$t_{VAR}$	Timing variation of all device settings	$V+ \geq 1.4V$		-10		10	%
		$V+ < 1.4V$		-15		15	
<b>DIGITAL INPUT/OUTPUT</b>							
$C_{IN}$	Input capacitance				3		pF
$V_{IH}$	Input logic high	$V+ < 1.4V$		$0.8 \times V+$			V
		$1.4V \leq V+$		$0.7 \times V+$			V
$V_{IL}$	Input logic low	$V+ < 1.4V$		-0.3		$0.2 \times V+$	V
		$1.4V \leq V+$		-0.3		$0.3 \times V+$	V
$V_{HYST}$	Hysteresis				0.1		V
$I_{IN}$	Input current					$\pm 0.1$	$\mu A$
$V_{OL}$	Output logic	$V+ \geq 1.4V$	$I_{OL} = -3mA$		0.13	0.4	V
		$V+ < 1.4V$	$I_{OL} = -0.75mA$			0.2	V
<b>POWER SUPPLY</b>							
$I_{DD\_ACTI}$ $I_{VE}$	Supply current during active conversion	Active Conversion, serial bus idle			55	90	$\mu A$
$I_{DD\_AVG}$	Average current consumption	Continous conversion mode 1Hz conversion period	Serial bus idle		3.2		$\mu A$
			SCL = 1MHz		13.5		
$I_{DD\_SB}$	Standby current <sup>(4)</sup>	Continous conversion mode Serial bus idle			2.6	5	$\mu A$
$I_{DD\_SD}$	Shutdown current	$T_A = +25^\circ C$ , Serial bus inactive			0.15	0.35	$\mu A$
		$T_A = -40^\circ C$ to $125^\circ C$				1.5	
		Serial bus active, SCL frequency = 400kHz			5.5		
		Serial bus active, SCL frequency = 1MHz			13		
$V_{POR}$	Power-on reset threshold voltage	Supply rising			1.02	1.06	V
	Brownout detect	Supply falling		0.94	0.97		V
$t_{INIT}$	Power-on reset time				0.5		ms

## 6.5 Electrical Characteristics (続き)

Over free-air temperature range and  $V+ = 1.14V$  to  $5.5V$  (unless otherwise noted); Typical specifications are at  $T_A = 25^\circ C$  and  $V+ = 3.3V$  (unless otherwise noted)

PARAMETER		TEST CONDITIONS	MIN	TYP	MAX	UNIT
$t_{RESET}$	Reset Time	General Call Reset		0.1		ms

- (1) Repeatability is the ability to reproduce a reading when the measured temperature is applied consecutively, under the same conditions.
- (2) Long term stability is determined using accelerated operational life testing at a junction temperature of  $150^\circ C$ .
- (3) Hysteresis is defined as the ability to reproduce a temperature reading as the temperature varies from room  $\rightarrow$  hot  $\rightarrow$  room  $\rightarrow$  cold  $\rightarrow$  room. The temperatures used for this test are  $-40^\circ C$ ,  $25^\circ C$ , and  $125^\circ C$ .
- (4) Quiescent current between periods

## 6.6 I<sup>2</sup>C Interface Timing

minimum and maximum specifications are over –40°C to 125°C and V+ = 1.14V to 5.5V (unless otherwise noted)<sup>(1)</sup>

		FAST MODE		FAST MODE PLUS		UNIT
		MIN	MAX	MIN	MAX	
f <sub>(SCL)</sub>	SCL operating frequency	1	400	1	1000	kHz
t <sub>(BUF)</sub>	Bus-free time between STOP and START conditions	0.6		0.5		μs
t <sub>(SUSTA)</sub>	Repeated START condition setup time	0.6		0.26		μs
t <sub>(HDSTA)</sub>	Hold time after repeated START condition. After this period, the first clock is generated.	0.6		0.26		μs
t <sub>(SUSTO)</sub>	STOP condition setup time	0.6		0.26		μs
t <sub>(HDDAT)</sub>	Data hold time <sup>(2)</sup>	100	900	12	150	ns
t <sub>(SUDAT)</sub>	Data setup time	100		50		ns
t <sub>(LOW)</sub>	SCL clock low period	1.3		0.5		μs
t <sub>(HIGH)</sub>	SCL clock high period	0.6		0.26		μs
t <sub>(VDAT)</sub>	Data valid time (data response time) <sup>(3)</sup>		0.9		0.45	μs
t <sub>R</sub>	SDA, SCL rise time		300		120	ns
t <sub>F</sub>	SDA, SCL fall time		300	20 x (V+ / 5.5V)	120	ns
t <sub>timeout</sub>	Timeout (SCL = GND or SDA = GND)	30		30		ms
t <sub>LPF</sub>	Glitch suppression filter	50		50		ns

- (1) The controller and device have the same V+ value. Values are based on statistical analysis of samples tested during initial release.
- (2) The maximum t<sub>(HDDAT)</sub> can be 0.9μs for fast mode, and is less than the maximum t<sub>(VDAT)</sub> by a transition time.
- (3) t<sub>(VDAT)</sub> = time for data signal from SCL LOW to SDA output (HIGH to LOW, depending on which is worse).



図 6-1. Two-Wire Timing Diagram

## 6.8 Typical Characteristics

at  $T_A = 25^\circ\text{C}$  and  $V_+ = 3.3\text{V}$  (unless otherwise noted)

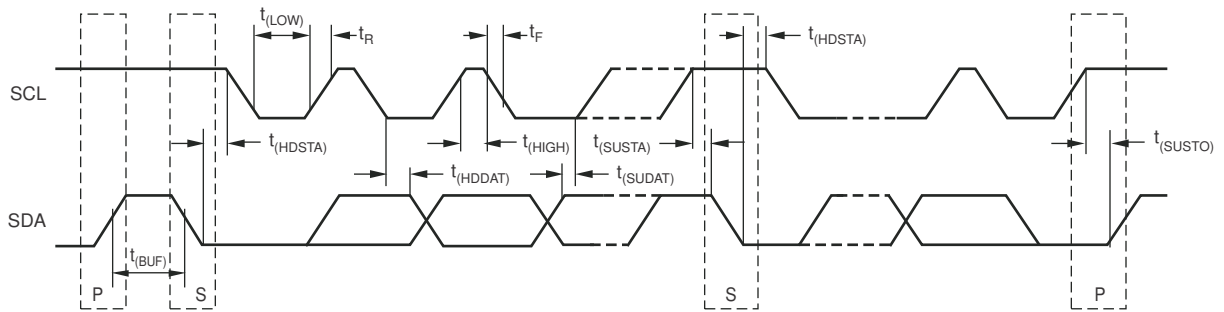
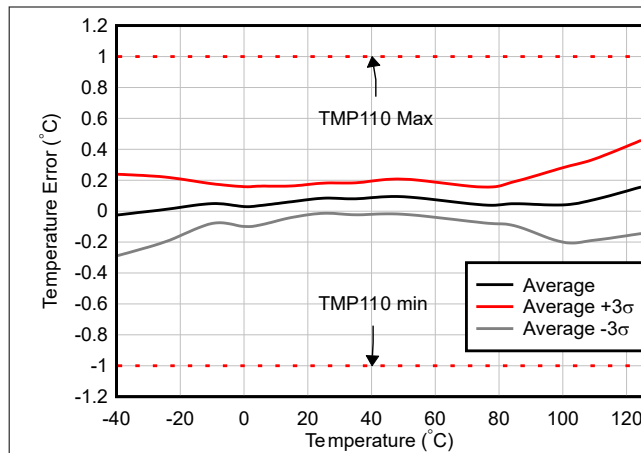

Figure 6-2. Temperature Error vs Temperature

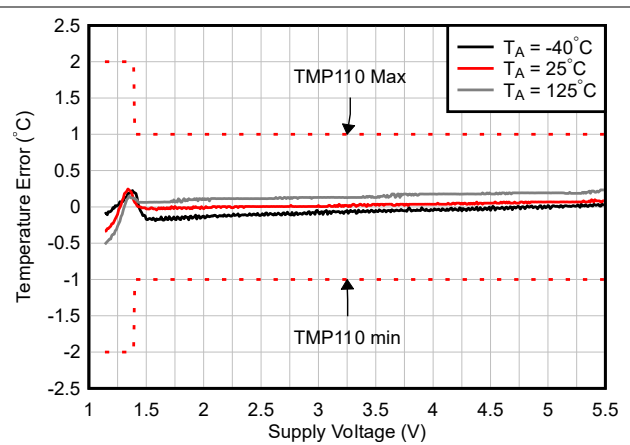

Figure 6-3. Temperature Error vs Supply Voltage

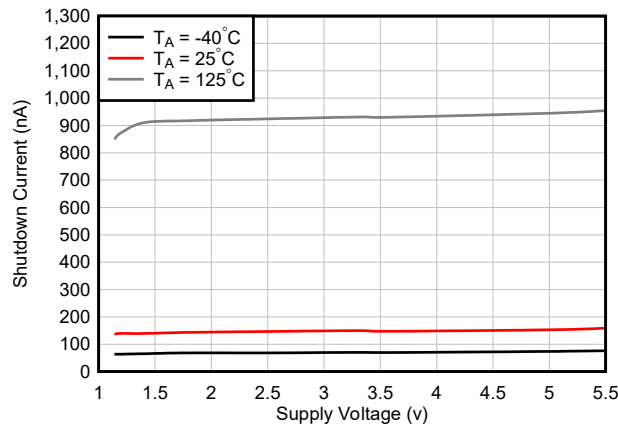
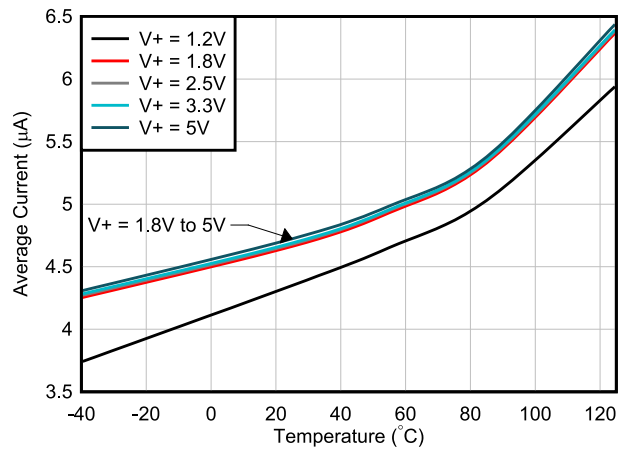

Figure 6-4. Shutdown Current vs Supply Voltage



Four conversions per second (continuous conversion mode)

Figure 6-5. Average Quiescent Current vs Temperature

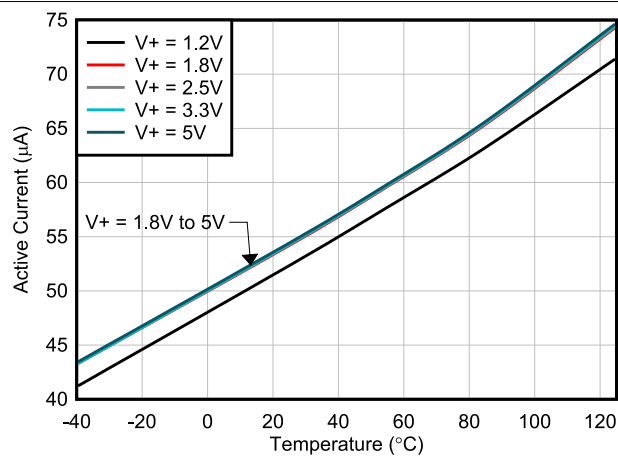

Figure 6-6. Active Conversion Current vs Temperature

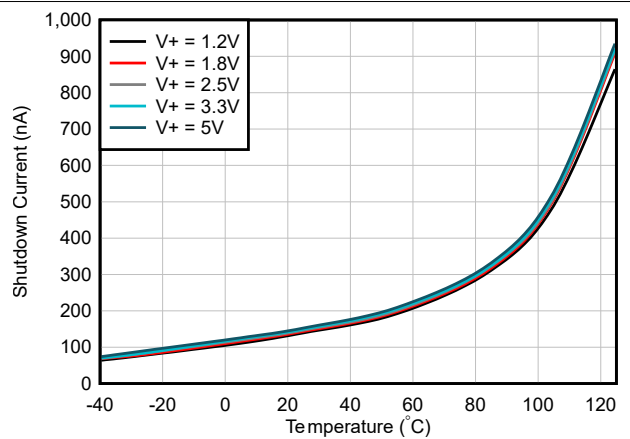

Figure 6-7. Shutdown Current vs Temperature



## 6.8 Typical Characteristics (continued)

at  $T_A = 25^\circ\text{C}$  and  $V_+ = 3.3\text{V}$  (unless otherwise noted)

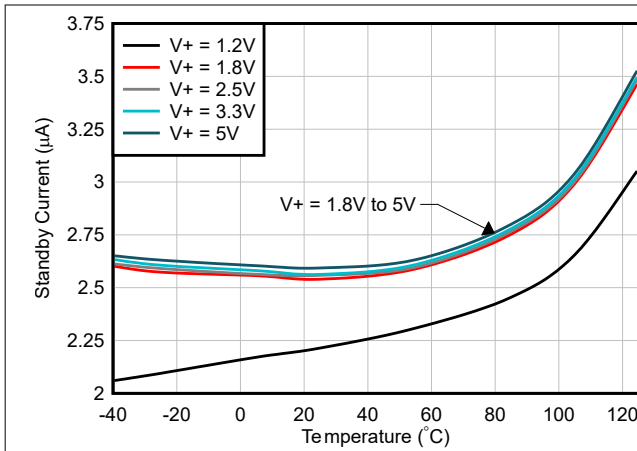

Figure 6-8. Standby Current vs Temperature

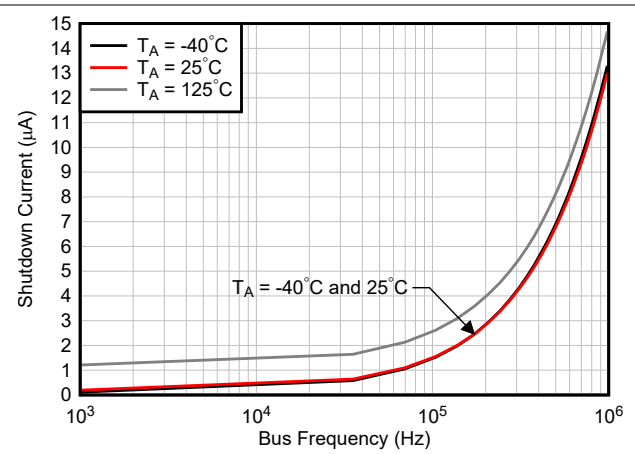

Figure 6-9. Shutdown Current vs Bus Frequency (Temperature at 3.3V Supply)

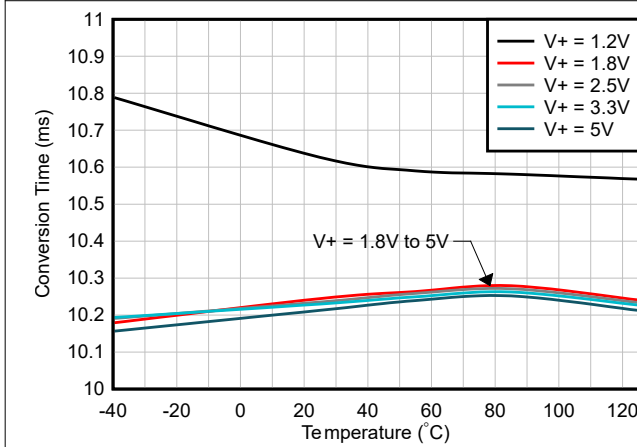

Figure 6-10. Conversion Time vs Temperature

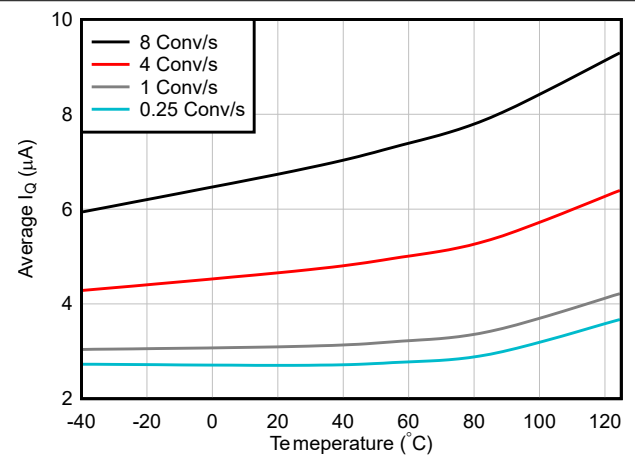

Figure 6-11. Average Supply Current vs Conversion Rate

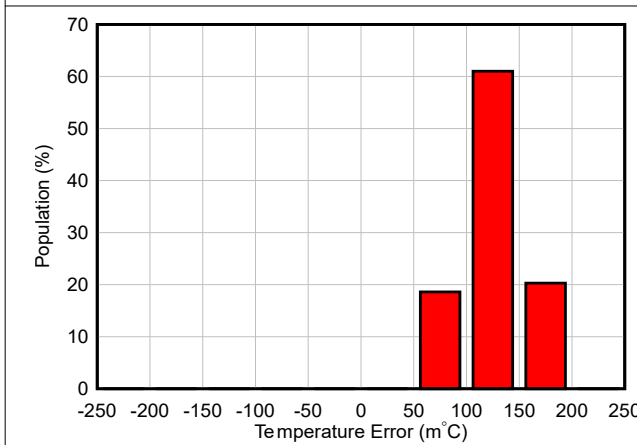

Figure 6-12. Temperature Error at  $25^\circ\text{C}$

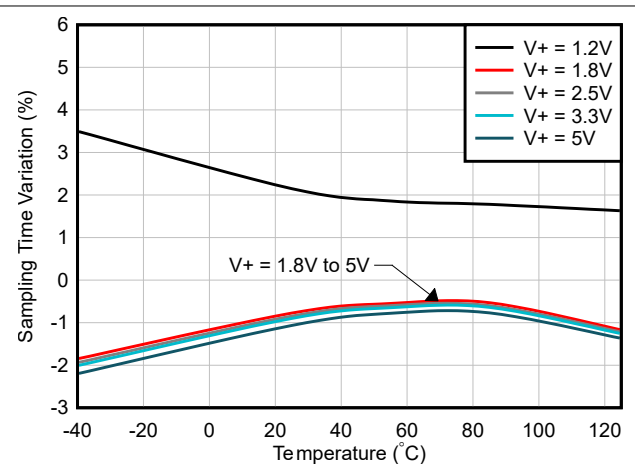
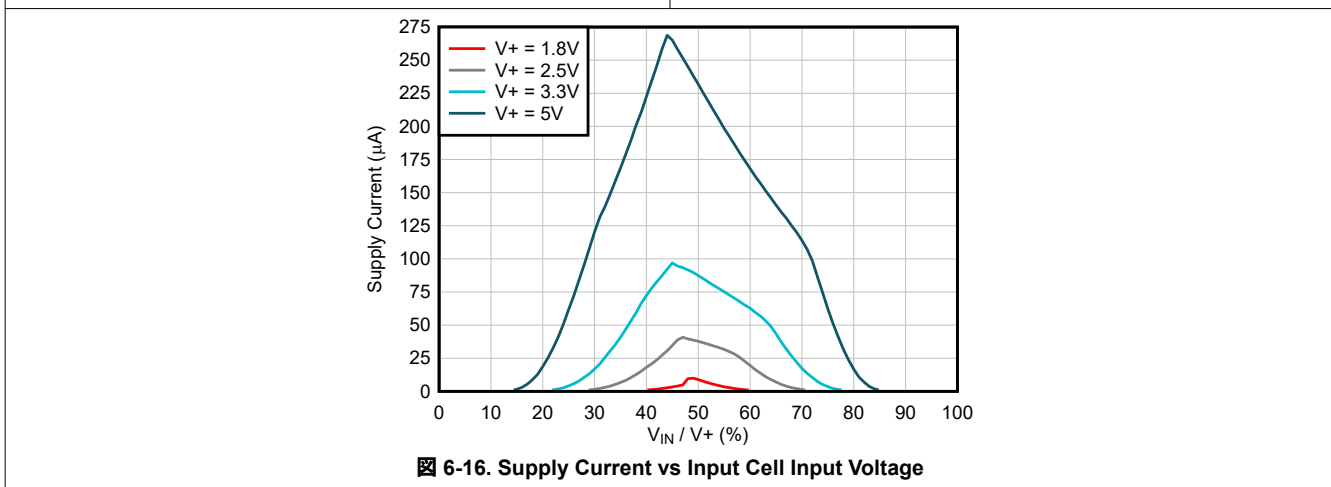
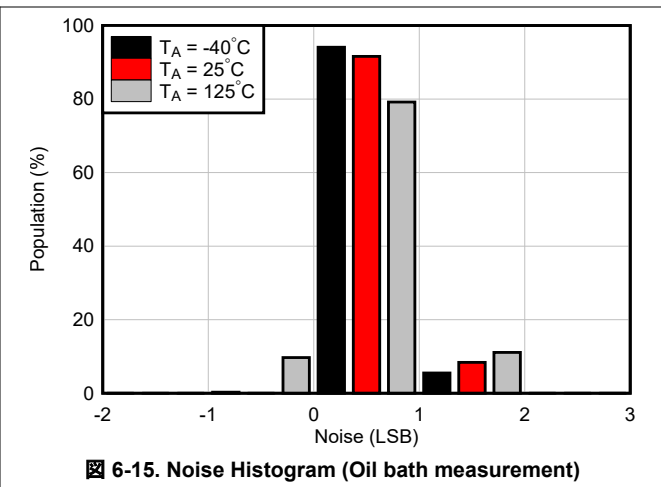
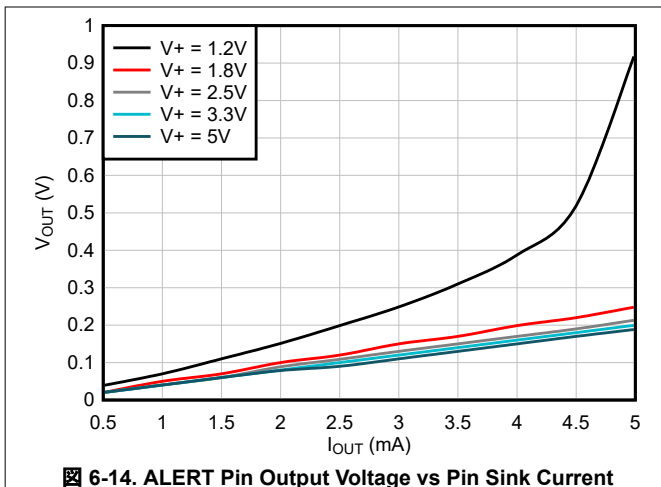

Figure 6-13. Sampling Time vs Temperature

### 6.8 Typical Characteristics (continued)

at  $T_A = 25^\circ\text{C}$  and  $V_+ = 3.3\text{V}$  (unless otherwise noted)



## 7 Detailed Description

### 7.1 Overview

The TMP110 is a digital output temperature sensor that comes factory calibrated for accuracy. The device features a two-wire, SMBus and I<sup>2</sup>C compatible interface with two modes of operation: continuous conversion mode and one-shot conversion mode, designed for thermal management and thermal protection applications. The TMP110 also includes an alert status register with individual high and low thresholds. Depending on the application requirement the 5<sup>th</sup> pin is either a device address input pin for multiple devices on the same bus or an open-drain alert output pin for thermal switch application.

### 7.2 Functional Block Diagram

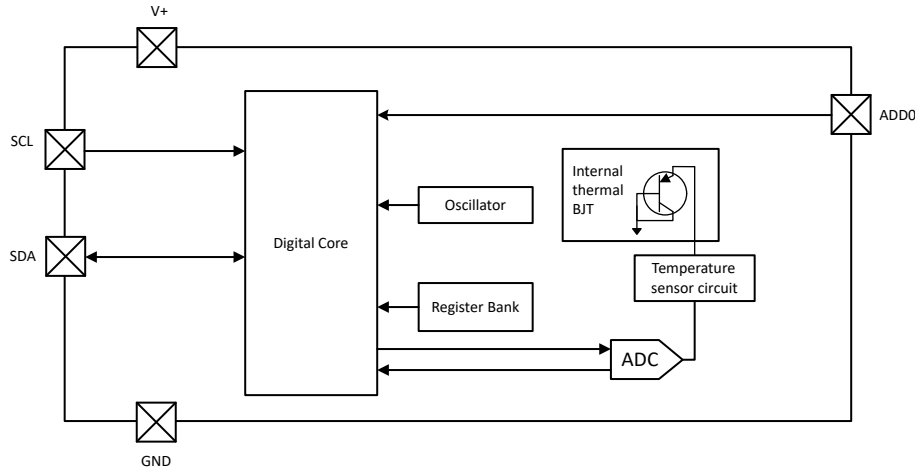

☒ 7-1. Address Variant

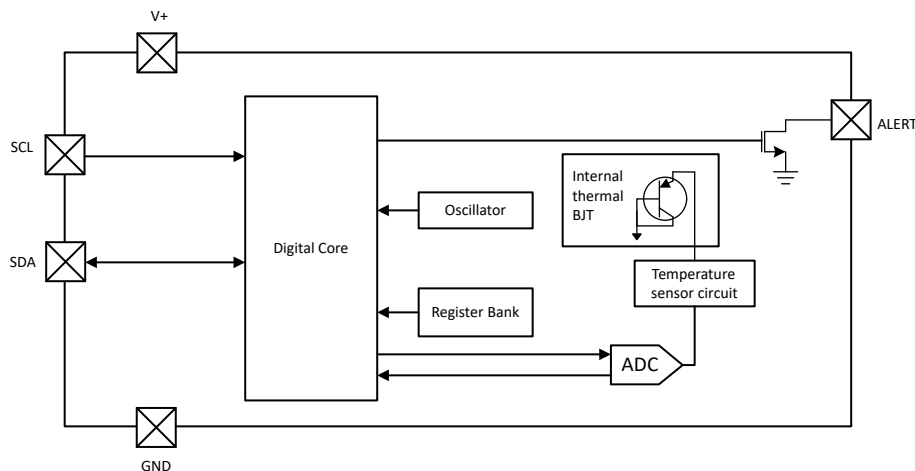

☒ 7-2. Alert Variant

### 7.3 Feature Description

#### 7.3.1 Digital Temperature Output

The digital output from each temperature measurement is stored in the read-only temperature register. The temperature register of the TMP110 device is configured as a 12-bit, read-only register (configuration register EM bit = 0), or as a 13-bit, read-only register (configuration register EM bit = 1) that stores the output of the most

recent conversion. Note that the EM bit defaults to 0 (12-bit format). As this value limits the highest temperature digital code, the device output is as shown in 表 7-1.

**表 7-1. 12/13-Bit Temperature Data Guidelines**

EM Bit	Temperature Bit Length	Q Notation	LSB (°C)	Range (+)
0	12	4	0.0625	127.93475
1	13	4	0.0625	256

Two bytes must be read to obtain data. Byte 1 is the most significant byte (MSB), followed by byte 2, the least significant byte (LSB). The first 12 bits (13 bits in extended mode) are used to indicate temperature. The least significant byte does not have to be read if that information is not needed. The data format for temperature is summarized in 表 7-2 and 表 7-3. One LSB equals 0.0625°C. Negative numbers are represented in binary two's-complement format. Following power-up or reset, the temperature register reads 0°C until the first conversion is complete. Bit D0 of byte 2 indicates normal mode (EM bit = 0) or extended mode (EM bit = 1), and can be used to distinguish between the two temperature register data formats. The unused bits in the temperature register always read 0.

**表 7-2. 12-Bit Temperature Data Format**

TEMPERATURE (°C)	DIGITAL OUTPUT (BINARY)	HEX
>127.9375	0111 1111 1111	7FF
127.9375	0111 1111 1111	7FF
100	0110 0100 0000	640
80	0101 0000 0000	500
75	0100 1011 0000	4B0
50	0011 0010 0000	320
25	0001 1001 0000	190
0.25	0000 0000 0100	004
0.0625	0000 0000 0001	001
0	0000 0000 0000	000
-0.0625	1111 1111 1111	FFF
-0.25	1111 1111 1100	FFC
-25	1110 0111 0000	E70
-55	1100 1001 0000	C90

表 7-2 does not list all temperatures. Use the following rules to obtain the digital data format for a given temperature or the temperature for a given digital data format.

To convert positive temperatures to a digital data format:

1. Divide the temperature by the resolution
2. Convert the result to binary code with a 12-bit, left-justified format, and MSB = 0 to denote a positive sign.

Example:  $(50^{\circ}\text{C}) / (0.0625^{\circ}\text{C} / \text{LSB}) = 800 = 320\text{h} = 0011\ 0010\ 0000$

To convert a positive digital data format to temperature:

1. Convert the 12-bit, left-justified binary temperature result, with the MSB = 0 to denote a positive sign, to a decimal number.
2. Multiply the decimal number by the resolution to obtain the positive temperature.

Example:  $0011\ 0010\ 0000 = 320\text{h} = 800 \times (0.0625^{\circ}\text{C} / \text{LSB}) = 50^{\circ}\text{C}$

To convert negative temperatures to a digital data format:

1. Divide the absolute value of the temperature by the resolution, and convert the result to binary code with a 12-bit, left-justified format.
2. Generate the twos complement of the result by complementing the binary number and adding one. Denote a negative number with MSB = 1.

Example:  $(|-25^{\circ}\text{C}|) / (0.0625^{\circ}\text{C} / \text{LSB}) = 400 = 190\text{h} = 0001\ 1001\ 0000$

Two's complement format:  $1110\ 0110\ 1111 + 1 = 1110\ 0111\ 0000$

To convert a negative digital data format to temperature:

1. Generate the twos complement of the 12-bit, left-justified binary number of the temperature result (with MSB = 1, denoting negative temperature result) by complementing the binary number and adding one. This represents the binary number of the absolute value of the temperature.
2. Convert to decimal number and multiply by the resolution to get the absolute temperature, then multiply by -1 for the negative sign.

Example:  $1110\ 0111\ 0000$  has twos complement of  $0001\ 1001\ 0000 = 0001\ 1000\ 1111 + 1$

Convert to temperature:  $0001\ 1001\ 0000 = 190\text{h} = 400$ ;  $400 \times (0.0625^{\circ}\text{C} / \text{LSB}) = 25^{\circ}\text{C} = (|-25^{\circ}\text{C}|); (|-25^{\circ}\text{C}|) \times (-1) = -25^{\circ}\text{C}$

**表 7-3. 13-Bit Temperature Data Format**

TEMPERATURE (°C)	DIGITAL OUTPUT (BINARY)	HEX
150	0 1001 0110 0000	0960
128	0 1000 0000 0000	0800
127.9375	0 0111 1111 1111	07FF
100	0 0110 0100 0000	0640
80	0 0101 0000 0000	0500
75	0 0100 1011 0000	04B0
50	0 0011 0010 0000	0320
25	0 0001 1001 0000	0190
0.25	0 0000 0000 0100	0004
0.0625	0 0000 0000 0001	0001
0	0 0000 0000 0000	0000
-0.0625	1 1111 1111 1111	1FFF
-0.25	1 1111 1111 1100	1FFC
-25	1 1110 0111 0000	1E70
-55	1 1100 1001 0000	1C90

### 7.3.2 Decoding Temperature Data

The TMP110 temperature registers use a 12-bit format. The 12 bits are aligned to the left side, or most significant side, of the 16-bit word. The four unused bits are on the right side, or least significant side. For this reason, a shift is needed to discard the extra bits. 2's Complement is employed to describe negative temperatures. C code can easily convert the 2's Complement data when the data is typecast into the correct signed data type. Q notation describes the number of bits which represent a fractional result. 4 bits of fractional data, known as Q4, offers 0.0625°C resolution.

**表 7-4. 12-Bit Q4 Encoding Parameters**

PARAMETER	VALUE
Bits	12
Q	4
Resolution	0.0625

表 7-4. 12-Bit Q4 Encoding Parameters (続き)

PARAMETER	VALUE
Range (+)	127.9375
Range (-)	-128
25°C	0x0190

表 7-5. 12-Bit Q4 Bit Values in °C

	15	14	13	12	11	10	9	8	7	6	5	4	3	2	1	0
Sign	64	32	16	8	4	2	1	0.5	0.25	0.125	0.0625	-	-	-	-	-
-128	64	32	16	8	4	2	1	1/2	1/4	1/8	1/16	-	-	-	-	-
-2 <sup>7</sup>	2 <sup>6</sup>	2 <sup>5</sup>	2 <sup>4</sup>	2 <sup>3</sup>	2 <sup>2</sup>	2 <sup>1</sup>	2 <sup>0</sup>	2 <sup>-1</sup>	2 <sup>-2</sup>	2 <sup>-3</sup>	2 <sup>-4</sup>	-	-	-	-	-

```

/* 12-bit format will have 4 bits discarded by right shift
q4 is 0.062500 resolution
the following bytes represent 24.5C */
uint8_t byte1 = 0x18;
uint8_t byte2 = 0x80;
float f = (((int8_t) byte1 << 8 | byte2) >> 4) * 0.0625f;
int mC = (((int8_t) byte1 << 8 | byte2) >> 4) * 1000 >> 4;
int C = (int8_t) byte1;
    
```

Similarly, in extended mode, the temperature register is extended to a 13-bit format with the same resolution (Q4). This changes the range and effective bits but the resolution remains the same. For this reason, the bit shift also changes. Encoding and C code examples for extended mode are shown below.

表 7-6. 13-Bit Q4 Encoding Parameters

PARAMETER	VALUE
Bits	13
Q	4
Resolution	0.0625
Range (+)	255.9375
Range (-)	-256
25°C	0xC80

表 7-7. 13-Bit Q4 Bit Values in °C

	15	14	13	12	11	10	9	8	7	6	5	4	3	2	1	0
Sign	128	64	32	16	8	4	2	1	0.5	0.25	0.125	0.0625	-	-	-	-
-256	128	64	32	16	8	4	2	1	1/2	1/4	1/8	1/16	-	-	-	-
-2 <sup>8</sup>	2 <sup>7</sup>	2 <sup>6</sup>	2 <sup>5</sup>	2 <sup>4</sup>	2 <sup>3</sup>	2 <sup>2</sup>	2 <sup>1</sup>	2 <sup>0</sup>	2 <sup>-1</sup>	2 <sup>-2</sup>	2 <sup>-3</sup>	2 <sup>-4</sup>	-	-	-	-

```

/* 13-bit format will have 3 bits discarded by right shift
q4 is 0.062500 resolution
the following bytes represent 24.5C */
uint8_t byte1 = 0xC;
uint8_t byte2 = 0x40;
float f = (((int8_t) byte1 << 8 | byte2) >> 3) * 0.0625f;
int mC = (((int8_t) byte1 << 8 | byte2) >> 3) * 1000 >> 4;
int C = (((int8_t) byte1 << 8 | byte2) >> 3) >> 4;
    
```

### 7.3.3 Temperature Limits and Alert

The TMP110 has alert feature and uses the [TLow\\_limit](#) register for low threshold comparison and [THigh\\_Limit](#) register for high threshold comparison. The alert limit is programmed in the TMP110 in a 12-bit or 13-bit two's

complement format based on the Extended\_Mode setting in the [configuration](#) register, with a resolution of 62.5 m°C. At the end of each temperature conversion, the temperature result is compared with the high limit and low limit registers, and the alert status flag and/or ALERT pin is updated.

The alert status flag in configuration register and/or the ALERT pin are updated based on the Alert\_Mode and Polarity bit setting in the configuration register after every temperature conversion.

As shown in [Figure 7-3](#), in comparator mode (Alert\_Mode = 0b), the ALERT pin and status flag become active when the temperature equals or exceeds the value in THigh\_Limit for Fault number of consecutive conversions. The ALERT pin and status flag remain active until the temperature falls below the TLow\_Limit for the same number of consecutive conversions.

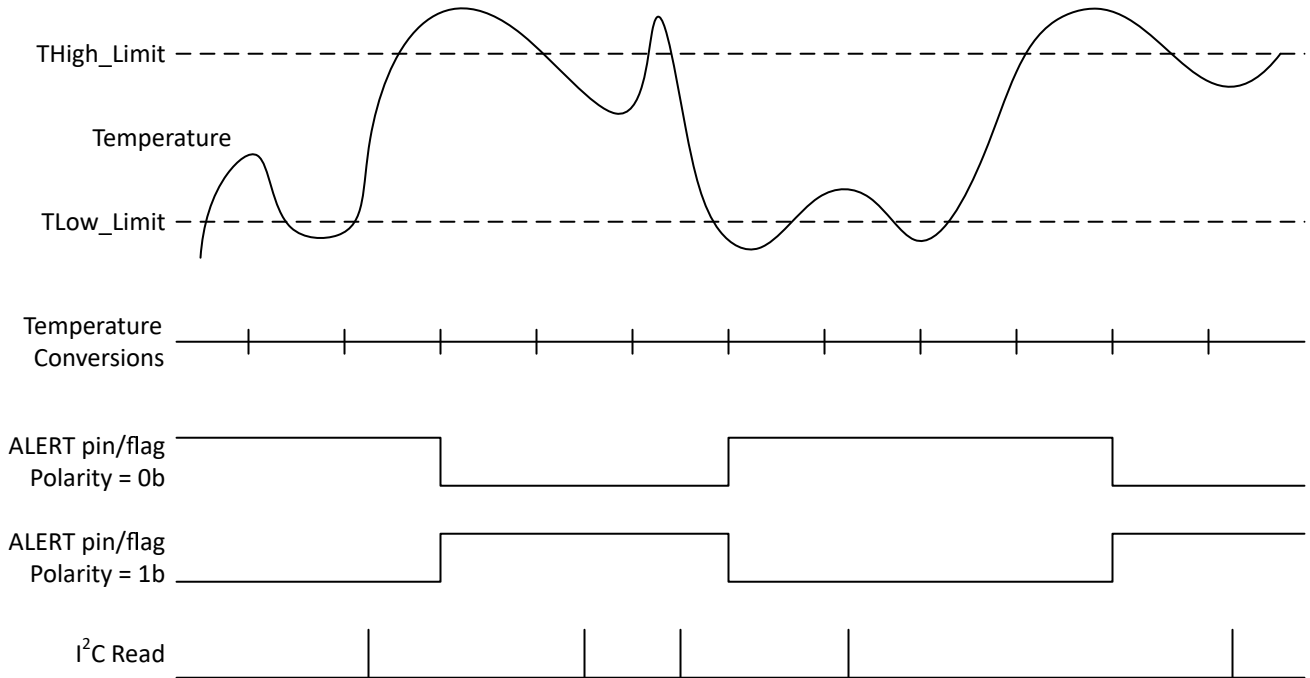

**Figure 7-3. Comparator Mode**

As shown in [Figure 7-4](#), in alert mode (Alert\_Mode = 1b), the ALERT pin becomes active only when the temperature equals or exceeds the THigh\_Limit for Fault number of consecutive conversion. The ALERT pin remains active, until a read operation of any register occurs, or the device responds to the SMBus Alert Response. When the ALERT pin is cleared, the pin becomes active only when the temperature is less than the TLow\_Limit for Fault number of consecutive conversion and remains active, until a read operation of any register occurs, or the device responds to the SMBus Alert Response. When the ALERT pin is cleared after a TLow\_Limit crossing, the above cycle repeats. The ALERT pin and status can also be cleared by issuing the General Call Reset command.



図 7-4. Alert Mode

## 7.4 Device Functional Modes

The TMP110 can be configured to operate in continuous or one-shot mode. This flexibility enables users to balance the requirements of power efficiency and performance.

### 7.4.1 Continuous-Conversion Mode

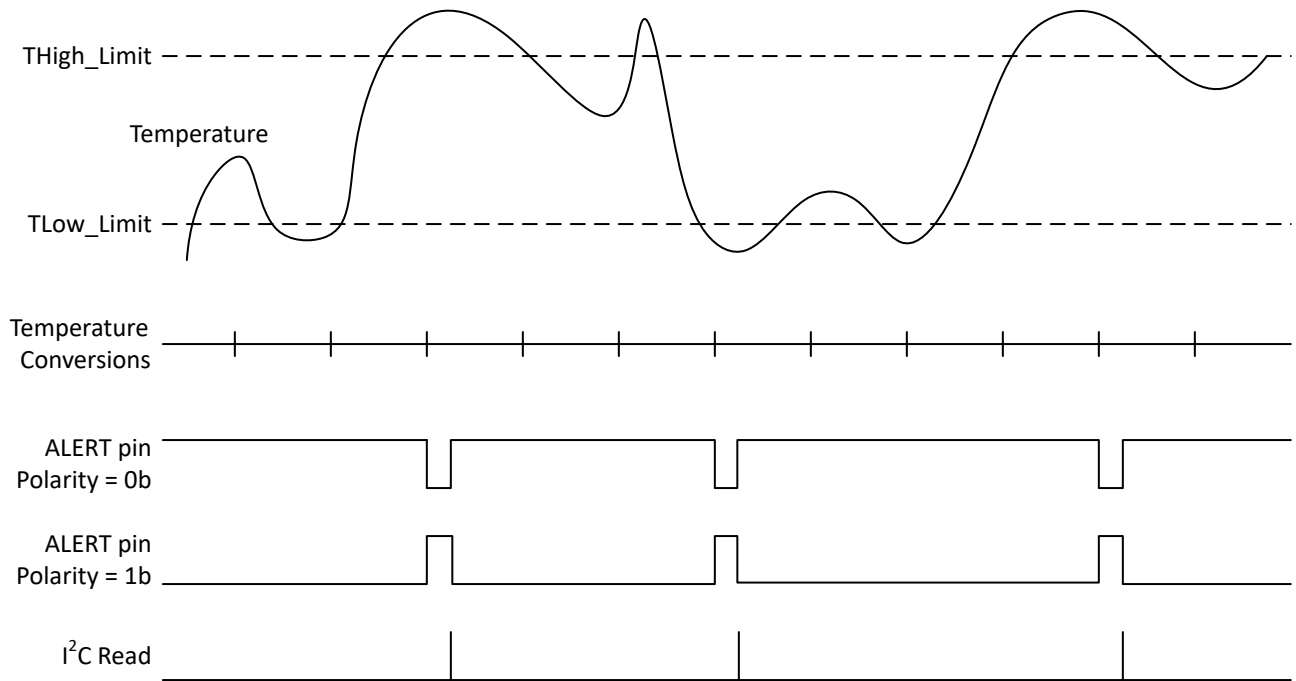
When the Shutdown bit is set to 0b in the configuration register, the device operates in continuous conversion mode. 図 7-5 shows the device in a continuous conversion cycle. In this mode, the device performs conversion at fixed intervals and updates the temperature result register, ALERT pin and flag at the end of every conversion. The typical active conversion time is around 10ms.



図 7-5. Continuous Conversion Cycle Timing Diagram

The Conversion\_Rate[1:0] bits in the configuration register controls the rate at which the conversions are performed. The device typically consumes 55μA during conversion and 2.6μA during the low power standby period. By decreasing the rate at which the conversion are performed, the application can benefit from reduced average current consumption in continuous mode.

Use 式 1 to calculate the average current in continuous mode.

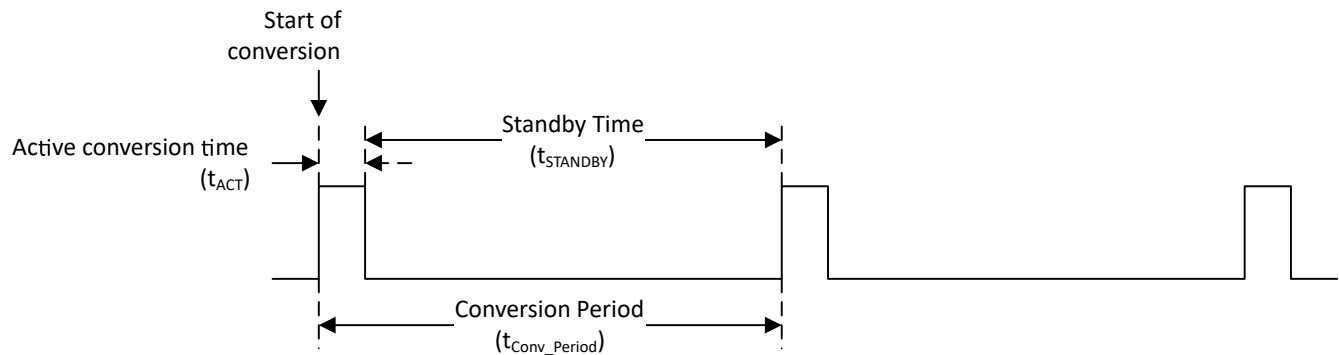

$$\text{Average Current} = ((I_{DD\_ACTIVE} \times t_{ACT}) + (I_{DD\_SB} \times t_{STANDBY})) / t_{Conv\_Period} \quad (1)$$

Where

- $t_{ACT}$  = Active conversion time
- $t_{Conv\_Period}$  = Conversion Period
- $t_{STANDBY}$  = Standby time between conversions calculated as  $t_{Conv\_Period} - t_{ACT}$

#### 7.4.2 One-Shot Mode

When a 1 is written to the One\_Shot bit in the configuration register, the TMP110 immediately starts a one-shot temperature conversion as shown in [Figure 7-6](#). Requesting another conversion when the TMP110 is performing a temperature conversion, the device does not stop the active conversion. After completing the one-shot conversion the TMP110 enters shutdown mode, and the One\_Shot bit is set to 1b.

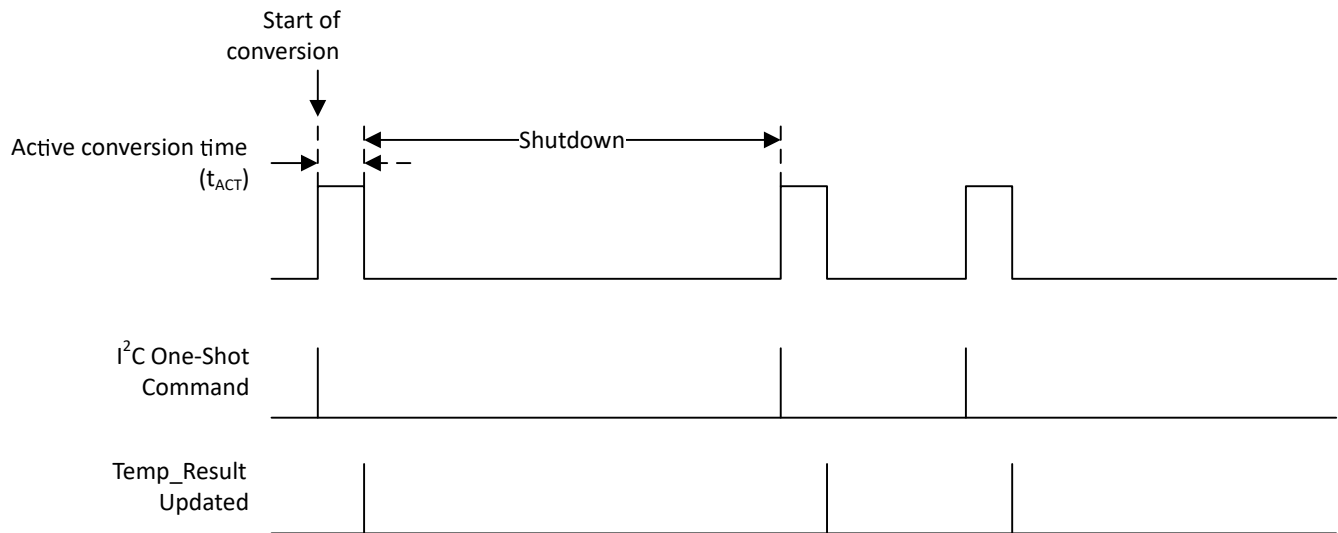

Figure 7-6. One-Shot Timing Diagram

The one-shot conversion is only supported when the Shutdown bit is set to 1b. Due to the short conversion time, the TMP110 device achieves a higher conversion rate. A single conversion typically takes 10ms and a read can take place in less than 20 $\mu$ s. When using the one-shot mode, 50 or more conversions per second are possible.

## 7.5 Programming

### 7.5.1 Serial Interface

The TMP110 has a standard bidirectional I<sup>2</sup>C interface that is controlled by a controller device in order to be configured or read the status of TMP110 device. Each target device on the I<sup>2</sup>C bus has a specific device address to differentiate between other target devices that are on the same I<sup>2</sup>C bus. Many target devices require configuration upon start-up to set the behavior of the device. This is typically done when the controller accesses internal register map of the target, which have unique register pointer. A device can have one or multiple registers where data is stored, written, or read. The TMP110 includes 50ns glitch suppression filters, allowing the device to coexist on an I<sup>3</sup>C mixed bus. The TMP110 supports transmission data rates up to 1MHz.

### 7.5.2 Bus Overview

The physical I<sup>2</sup>C interface consists of the serial clock (SCL) and serial data (SDA) lines. The SDA line must be connected to a supply through a pullup resistor. The size of the pullup resistor is determined by the amount of capacitance on the I<sup>2</sup>C lines, the communication frequency and I<sup>2</sup>C bus voltage. For further details, see the [I<sup>2</sup>C Pullup Resistor Calculation](#) application note. Data transfer can be initiated only when the bus is idle. A bus is

considered idle if both SDA and SCL lines are high after a STOP condition or time out events (see [7-7](#) and [7-8](#)).

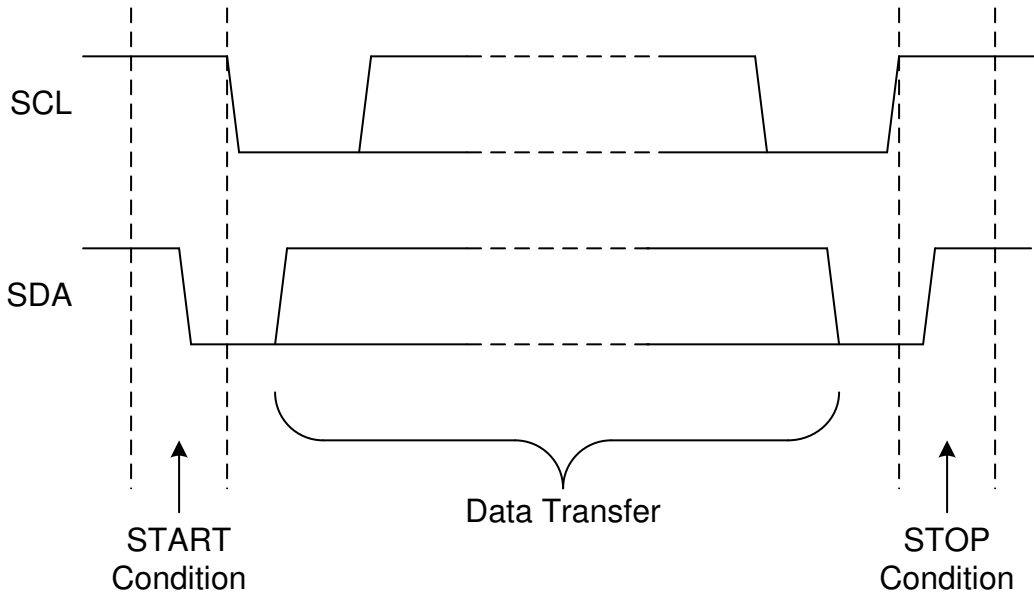

**7-7. Definition of Start and Stop Conditions**

SDA line is stable while SCL line is high

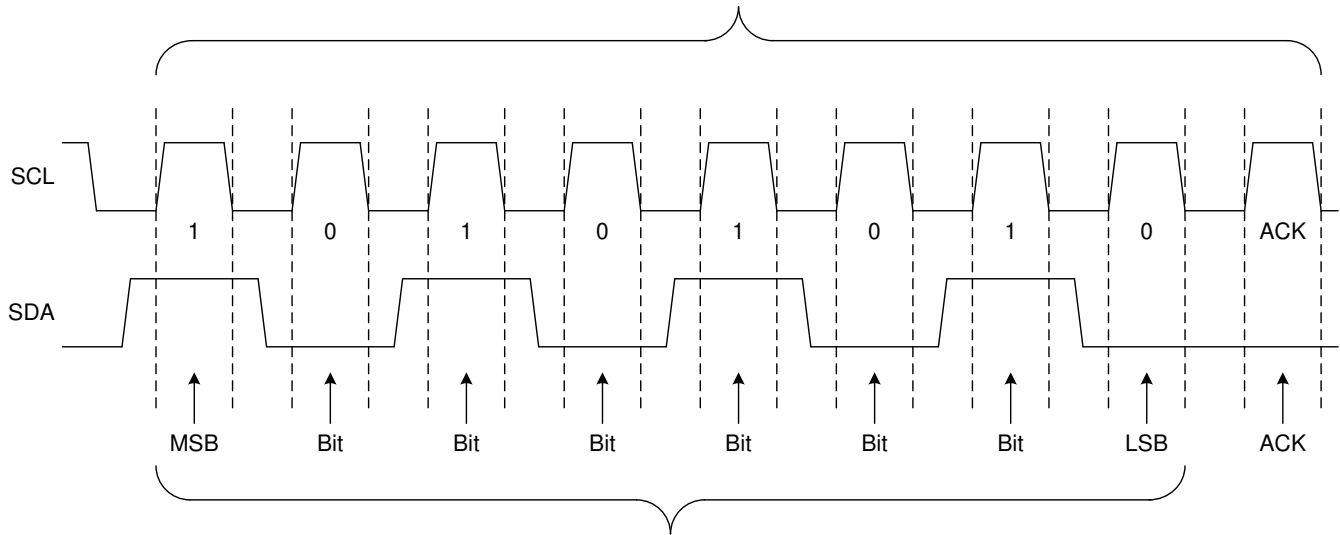

Byte: 1010 1010 (AAh)

**7-8. Bit Transfer**

### 7.5.3 Device Address

To communicate with the TMP110, the controller must first address target devices through an address byte. The address byte has seven address bits and a read-write (R/W) bit that indicates the intent of executing a read or write operation. The TMP110D features an address pin to allow up to four devices to be addressed on a single bus. [表 7-8](#) describes the pin logic levels used to properly connect up to eight devices on the same I<sup>2</sup>C bus. This table also describes four different address options available when ALERT pin is used.

表 7-8. Address and Alert Variant Device Target Address

DEVICE ORDERABLE		ADD0 PIN CONNECTION	DEVICE I <sup>2</sup> C BUS ADDRESS	DEVICE I <sup>2</sup> C BUS ADDRESS (7-bit Hex)
Address Variant	TMP110D	GND	1000000	40h
		V+	1000001	41h
		SDA	1000010	42h
		SCL	1000011	43h
Alert Variant	TMP110D0	N/A	1001000	48h
	TMP110D1		1001001	49h
	TMP110D2		1001010	4Ah
	TMP110D3		1001011	4Bh

## 7.5.4 Bus Transactions

### 7.5.4.1 Writes

To write on the I<sup>2</sup>C bus, the controller sends a START condition on the bus with the address of the target, as well as the last bit (the R/W bit) set to 0b, which signifies a write. The target acknowledges, letting the controller know the target is ready. After this operation, the controller starts sending the register pointer and data to the target, and the controller terminates the transmission with a STOP condition.

Writes to read-only registers or register locations outside of the register map is ignored. The TMP110 still performs and acknowledge when writing outside of the register map. 図 7-9 shows an example of writing a single word write communication.



図 7-9. Write to Single Register

### 7.5.4.2 Reads

For a read operation the controller sends a START condition, followed by the target address with the R/W bit set to 0b (signifying a write). The target acknowledges the write request, and the controller sends the register pointer. The controller initiates a restart followed by the target address with the R/W bit set to 1b (signifying a read). The controller continues to send out clock pulses but releases the SDA line so that the target can transmit data. At the end of every byte of data, the controller sends an ACK to the target, letting the target know that the controller is ready for more data. For repeated read operation from the same register (like temperature register), it is not needed to resend the register pointer. The read operation from the same register can be repeated as many time as the controller needs when the pointer is set. Once the controller has received the expected number of bytes, the controller sends a NACK, signaling to the target to halt communications and release the SDA line. The controller follows this up with a STOP condition. 図 7-10 shows an example of reading a single word from a target register.

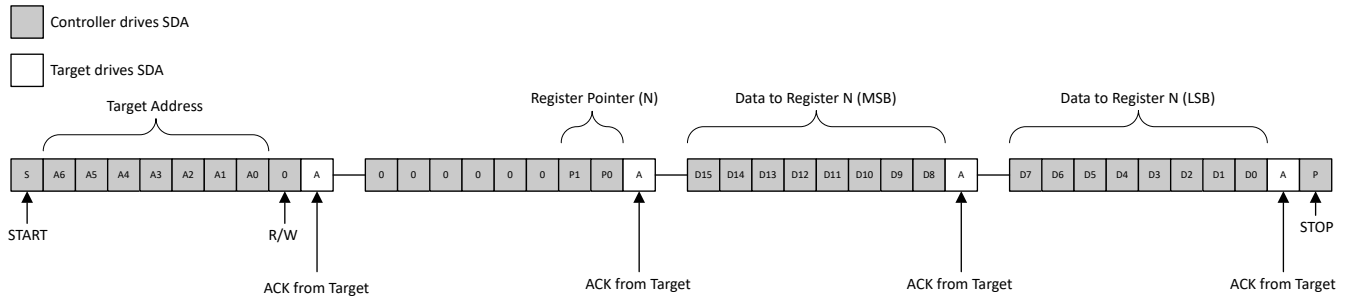
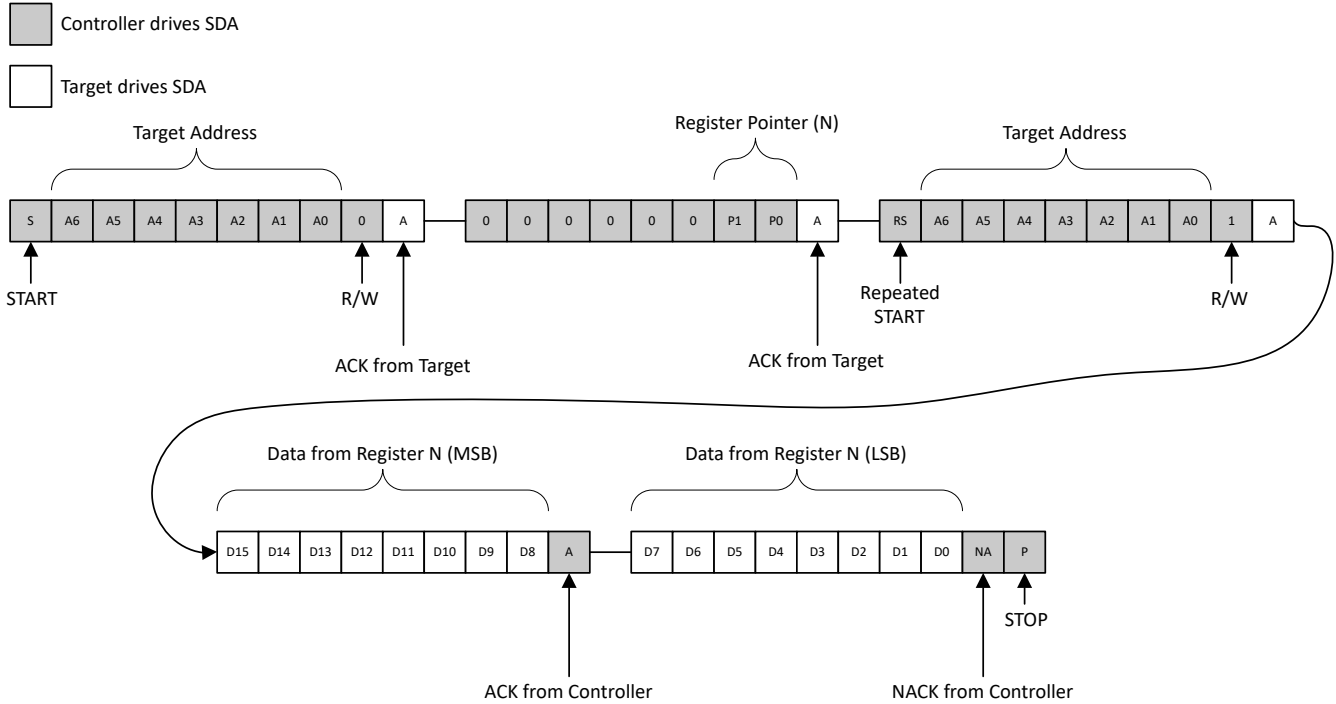

7-10. Read from Single Register

7.5.4.3 General Call Reset Function

The TMP110 responds to a general-call address (0000 000) if the eighth bit is 0b. The device acknowledges the general-call address and responds to commands in the second byte. If the second byte is 0000b 0110b, the TMP110 internal registers are reset to power-up values as shown in [SMBus General Call Reset Timing Diagram](#). The serial address is unaffected by the general call reset.

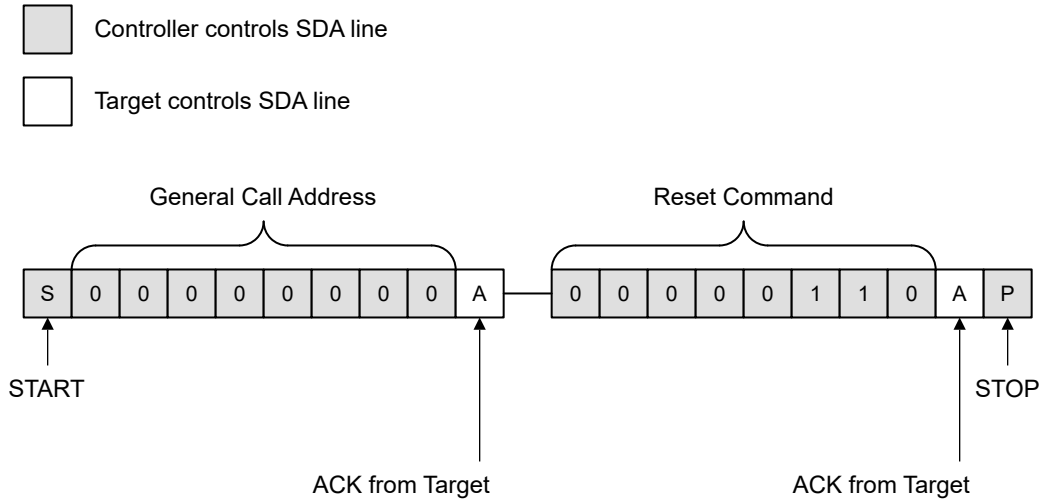

7-11. SMBus General Call Reset Timing Diagram

7.5.4.4 SMBus Alert Response

The TMP110 device supports the SMBus alert response. When the TMP110 operates in Alert Mode, and the ALERT pin is available, the controller can sense that an alert condition is present. Irrespective of the availability of the ALERT pin, the alert status is set. As shown in [7-12](#), if the controller sends an SMBus alert command (19h or 00011001b) on the bus, and the target is set, the device acknowledges the SMBus alert command and

responds by returning the device address on the SDA line. The eighth bit (LSB) of the device address byte indicates if the alert condition was caused by the temperature exceeding THigh\_Limit or falling below the TLow\_Limit. The value of the eighth bit follows the Polarity bit setting.

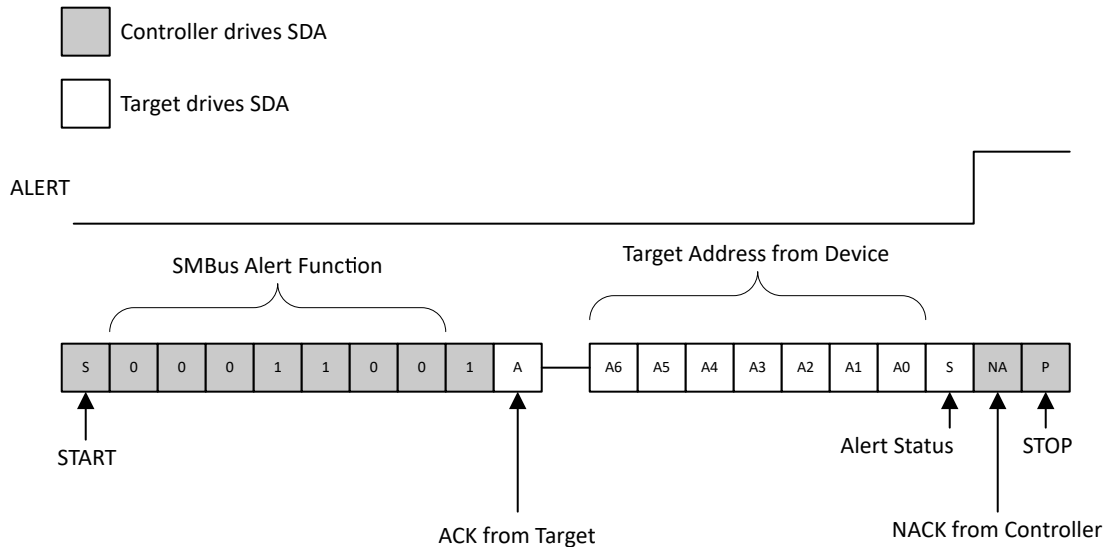

FIG 7-12. SMBus Alert Response

If multiple devices on the bus respond to the SMBus alert command, arbitration during the device address portion of the SMBus alert command determines which devices the ALERT pin is activated. The device with the lowest address wins the arbitration. On winning the arbitration, the TMP110 inactivates the ALERT pin and/or clears the status bit. To prevent the device with lowest I<sup>2</sup>C address in continuous conversion mode sees the alert line and halt others with higher I<sup>2</sup>C address to report the alert, the controller has to temporarily disable the Alert mode in device with smallest I<sup>2</sup>C address until all alerts in the system are cleared.

#### 7.5.4.5 Time-Out Function

The TMP110 resets the serial interface if the SCL line is held low by the controller or the SDA line is held low by the TMP110 for 30ms (typical) between a START and STOP condition. The TMP110 releases the SDA line if the SCL pin is pulled low and waits for a START condition from the controller. To avoid activating the timeout function, maintain a communication speed of at least 1kHz for the SCL operating frequency. If another device on the bus is holding the SDA pin low, the TMP110 does not reset.

#### 7.5.4.6 Coexist on I3C Mixed Bus

A bus with both I3C and I<sup>2</sup>C interfaces is referred to as a mixed with clock speeds up to 12.5MHz. The TMP110 is an I<sup>2</sup>C device that can be on the same bus that has an I3C device attached as the TMP110 incorporates a spike suppression filter of 50ns on the SDA and SCL pins to avoid any interference to the bus when communicating with I3C devices.

## 8 Register Map

表 8-1. TMP110 Register Map

ADDRESS	TYPE	RESET	ACRONYM	REGISTER NAME	SECTION
00h	R	xxxxh	Temp_Result	Temperature result register	<a href="#">Go</a>
01h	R/W	60A0h	Configuration	Configuration register	<a href="#">Go</a>
02h	R/W	4B00h	TLow_Limit	Temperature low limit register	<a href="#">Go</a>
03h	R/W	5000h	THigh_Limit	Temperature high limit register	<a href="#">Go</a>
04h - FFh	R	xxxxh	Reserved	Reserved	

表 8-2. TMP110 Register Section/Block Access Type Codes

Access Type	Code	Description
<b>Read Type</b>		
R	R	Read
RC	R C	Read to Clear
R-0	R -0	Read Returns 0s
<b>Write Type</b>		
W	W	Write
W0CP	W 0C P	W 0 to clear Requires privileged access
<b>Reset or Default Value</b>		
-n		Value after reset or the default value

## 8.1 Temp\_Result Register (address = 00h) [reset = xxxhx]

This register stores the latest temperature conversion result in a 12-bit or 13-bit two's complement format with a LSB equal to 0.0625°C depending on the Extended\_Mode bit setting in the [configuration](#) register. The default format for the register at power up is normal mode.

Return to [Register Map](#).

**表 8-3. Temp\_Result Register (Normal Mode)**

15	14	13	12	11	10	9	8
Temp_Result[11:4]							
R-xxh							
7	6	5	4	3	2	1	0
Temp_Result[3:0]				Reserved			
R-xh				R-0000b			

**表 8-4. Temp\_Result Register (Extended Mode)**

15	14	13	12	11	10	9	8
Temp_Result[12:5]							
R-xxh							
7	6	5	4	3	2	1	0
Temp_Result[4:0]				Reserved			
R-xxh				R-001b			

**表 8-5. Temp\_Result Register Field Description (Normal Mode)**

Bit	Field	Type	Reset	Description
15:4	Temp_Result[11:0]	R	xxxh	12-bit temperature conversion result Temperature data is represented by a 12-bit, two's complement word with an LSB equal to 0.0625°C when Extended_Mode bit is 0b
3:0	Reserved	R	0000b	Reserved

**表 8-6. Temp\_Result Register Field Description (Extended Mode)**

Bit	Field	Type	Reset	Description
15:3	Temp_Result[12:0]	R	xxxh	13-bit temperature conversion result Temperature data is represented by a 13-bit, two's complement word with an LSB equal to 0.0625°C when Extended_Mode bit is 1b
2:0	Reserved	R	001b	Reserved (The LSB is 1b)

## 8.2 Configuration Register (address = 01h) [reset = 60A0h]

This register is used to configure the operation of the TMP110 and also provides the alert status when ALERT pin is not available on the pin-out.

Return to [Register Map](#).

**表 8-7. Configuration Register**

15	14	13	12	11	10	9	8
One_Shot	Reserved		Fault[1:0]		Polarity	Alert_Mode	Shutdown
R/W-0b	R-11b		R/W-00b		R/W-0b	R/W-0b	R/W-0b
7	6	5	4	3	2	1	0
Conversion_Rate[1:0]		Alert	Extended_Mode	Reserved			
R/W-10b		R-1b	R/W-0b	R-0000b			

**表 8-8. Configuration Register Field Description**

Bit	Field	Type	Reset	Description
15	One_Shot	R/W	0b	One-shot conversion trigger applicable in shutdown mode only. In continuous conversion mode the bit reads 0b. In shutdown mode the bit reads 1b. Triggering a one-shot conversion happens only when the TMP110 is in shutdown mode. 0b = Active conversion ongoing 1b = Trigger a one-shot conversion or active conversion complete
14:13	Reserved	R	11b	Reserved
12:11	Fault[1:0]	R/W	00b	The fault bit is used to count the number of consecutive conversions for which the alert condition exists before the ALERT pin is asserted or status bit is set. 00b = 1 fault 01b = 2 faults 10b = 4 faults 11b = 6 faults
10	Polarity	R/W	0b	The polarity bit allows the host to adjust the polarity of the ALERT pin/flag output. 0b = ALERT pin/flag output is active low 1b = ALERT pin/flag output is active high
9	Alert_Mode	R/W	0b	The alert mode bit indicates the how the temperature limits operate. 0b = Comparator mode 1b = Alert mode
8	Shutdown	R/W	0b	The shutdown bit is used to change the device conversion mode. 0b = Continuous conversion mode 1b = Shutdown mode
7:6	Conversion_Rate[1:0]	R/W	10b	The conversion rate bits configure the TMP110 conversion period. The default is conversion every 250ms. 00b = 4s / 0.25Hz 01b = 1s / 1Hz 10b = 0.25s / 4Hz 11b = 0.125s / 8Hz
5	Alert flag	R	1b	The alert is a read-only bit which provides the information about the alert status in comparator mode and is not affected by Alert_Mode setting. The polarity bit affects the alert flag.
4	Extended_Mode	R/W	0b	The extended mode bit configures the temperature format. 0b = Normal format with 12-bit 1b = Extended format with 13-bit
3:0	Reserved	R	0000b	Reserved



### 8.3 TLow\_Limit Register (address = 02h) [reset = 4B00h]

This register is used to configure the low temperature alert limit of the TMP110. The limit is formatted in a 12-bit or 13-bit two's complement format with a LSB equal to 62.5 m°C depending on the Extended\_Mode bit setting in the [configuration](#) register. The default value on start-up is 4B00h or 75 °C in normal mode format.

**Note:** If the temperature register format is changed, the low limit register value must be updated accordingly.

Return to [Register Map](#).

**表 8-9. TLow\_Limit Register (Normal Mode)**

15	14	13	12	11	10	9	8
TLow_Limit[11:4]							
R/W-4Bh							
7	6	5	4	3	2	1	0
TLow_Limit[3:0]				Reserved			
R/W-0h				R-0000b			

**表 8-10. TLow\_Limit Register (Extended Mode)**

15	14	13	12	11	10	9	8
TLow_Limit[12:5]							
R/W-4Bh							
7	6	5	4	3	2	1	0
TLow_Limit[4:0]				Reserved			
R/W-00h				R-000b			

**表 8-11. TLow\_Limit Register Field Description (Normal Mode)**

Bit	Field	Type	Reset	Description
15:4	TLow_Limit[11:0]	R/W	4B0h	12-bit temperature low limit setting. Temperature low limit is represented by a 12-bit, two's complement word with an LSB equal to 62.5 m°C when Extended_Mode bit is 0b. The default setting for this is 75°C.
3:0	Reserved	R	0000b	Reserved

**表 8-12. TLow\_Limit Register Field Description (Extended Mode)**

Bit	Field	Type	Reset	Description
15:3	TLow_Limit[12:0]	R/W	4B00h	13-bit temperature low limit setting. Temperature low limit is represented by a 13-bit, two's complement word with an LSB equal to 62.5 m°C when Extended_Mode bit is 1b.
2:0	Reserved	R	000b	Reserved

### 8.4 THigh\_Limit Register (address = 03h) [reset = 5000h]

This register is used to configure the high temperature alert limit of the TMP110. The limit is formatted in a 12-bit or 13-bit two's complement format with a LSB equal to 62.5 m°C depending on the Extended\_Mode bit setting in the [configuration](#) register. The default value on start-up is 5000h or 80 °C in normal mode format.

**Note:** If the temperature register format is changed, the high limit register value must be updated accordingly.

Return to [Register Map](#).

**表 8-13. THigh\_Limit Register (Normal Mode)**

15	14	13	12	11	10	9	8
THigh_Limit[11:4]							
R/W-50h							
7	6	5	4	3	2	1	0
THigh_Limit[3:0]				Reserved			
R/W-0h				R-0000b			

**表 8-14. THigh\_Limit Register (Extended Mode)**

23	22	21	20	19	18	17	16
THigh_Limit[12:5]							
R/W-50h							
7	6	5	4	3	2	1	0
THigh_Limit[4:0]				Reserved			
R/W-0h				R-000b			

**表 8-15. THigh\_Limit Register Field Description (Normal Mode)**

Bit	Field	Type	Reset	Description
15:4	THigh_Limit[11:0]	R/W	500h	12-bit temperature high limit setting. Temperature high limit is represented by a 12-bit, two's complement word with an LSB equal to 62.5 m°C when Extended_Mode bit is 0b. The default setting for this is 80 °C.
3:0	Reserved	R	0000b	Reserved

**表 8-16. THigh\_Limit Register Field Description (Extended Mode)**

Bit	Field	Type	Reset	Description
15:3	THigh_Limit[12:0]	R/W	5000h	13-bit temperature low limit setting. Temperature low limit is represented by a 13-bit, two's complement word with an LSB equal to 62.5 m°C.
2:0	Reserved	R	000b	Reserved

## 9 Application and Implementation

### 注

以下のアプリケーション情報は、TI の製品仕様に含まれるものではなく、TI ではその正確性または完全性を保証いたしません。個々の目的に対する製品の適合性については、お客様の責任で判断していただくこととなります。お客様は自身の設計実装を検証しテストすることで、システムの機能を確認する必要があります。

### 9.1 Application Information

The TMP110 can be operated with a two-wire I<sup>2</sup>C or SMBus compatible interface and features the ability to operate with a 1.2V bus voltage. The TMP110 features a uniquely small size of 0.8mm × 0.8mm with a 0.4mm z-height for space-constrained applications.

### 9.2 Equal I<sup>2</sup>C Pullup and Supply Application



図 9-1. Equal I<sup>2</sup>C Pullup and Supply Voltage Application

#### 9.2.1 Design Requirements

For this design example, use the parameters listed below.

表 9-1. Design Parameters

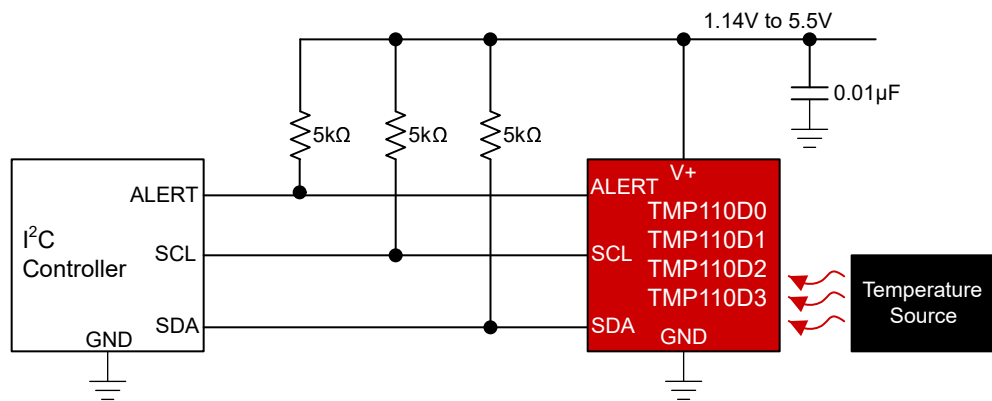
PARAMETER	VALUE
Supply (V+)	1.14V to 5.5V
SDA, SCL V <sub>PULLUP</sub>	V+
SDA SCL R <sub>PULLUP</sub>	5kΩ

#### 9.2.2 Detailed Design Procedure

The SDA and SCL pin voltage of the TMP110 can be the same as the supply voltage V+. The accuracy of the TMP110 is not affected by the pullup voltage. However, using a minimal SDA and ALERT pins pull-up current is recommended to prevent self-heating and temperature accuracy reduction. In addition, it is recommended to not have any communication on I<sup>2</sup>C bus during temperature conversion to minimize measurement noise.

#### 9.2.3 Application Curve

図 9-2 shows the step response of the TMP110 to a submersion in an oil bath of 75°C from room temperature (25°C). The time-constant, or the time for the output to reach 63% of the input step, is 1.45s. The time-constant result depends on the printed-circuit board (PCB) size that the TMP110 is mounted. For this test, the TMP110 is soldered to a two-layer PCB that measured 0.5 inches × 0.5 inches.

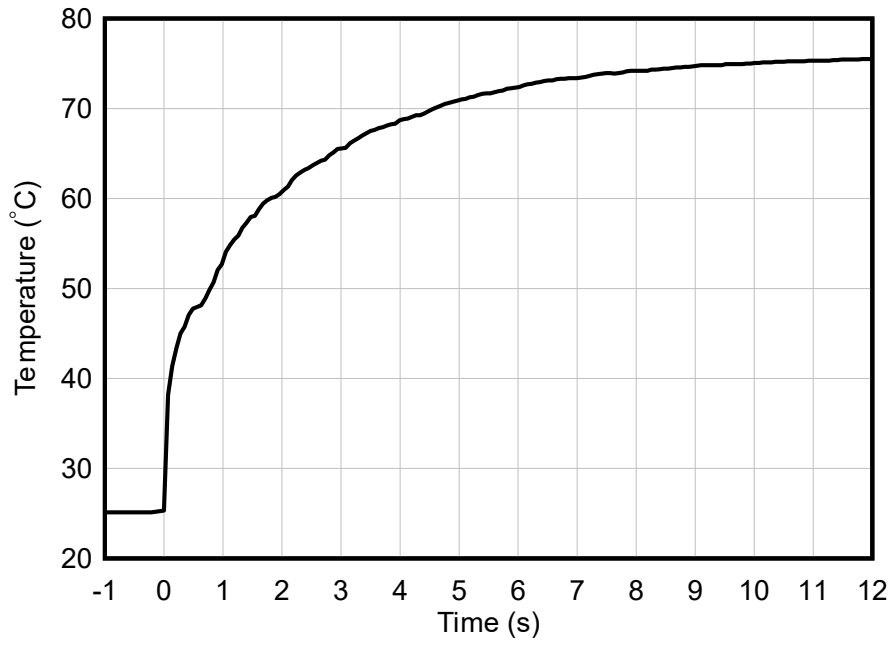

9-2. Temperature Step Response

### 9.2.4 Power Supply Recommendations

The TMP110 operates with power supply in the range of 1.14V to 5.5V. The device can measure temperature accurately in the full supply range. A power-supply bypass capacitor is required for proper operation. Place this capacitor as close as possible to the supply and ground pins of the device. A typical value for this supply bypass capacitor is 0.01 $\mu$ F. Applications with noisy or high-impedance power supplies can require additional decoupling capacitors to reject power-supply noise.

## 9.3 Layout

### 9.3.1 Layout Guidelines

The TMP110 is a simple device to layout. Place the power supply bypass capacitor as close as possible to the device as possible. Pull up the open-drain output pin SDA through pullup resistor.

### 9.3.2 Layout Example

There are special considerations that need to be taken for the TMP110 X2SON package. These considerations are due to the center pad being electrically connected to either address or alert (depending on the orderables shown in 表 7-8) and because of the dimensions of the package and the pads. With the address option, the center pad can be directly connected with a trace on the same layer to one of the 4 edge pins for setting the device address as shown in 図 9-3.



図 9-3. ADD0 Pin Layout Example

When using the ALERT pin of the device, a 4 mil trace can be routed between pins 1 and 5 or pins 2 and 4. This signal can be either routed out in between the pads or on a different layer using a via within the center pad as shown in  9-4. Both of these methods have constraints that must be considered as explained below. Ultimately, choosing one of these methods depends on the specifications of the board manufacturing process:

- **Option 1 (Routing in between pads):** introduces trace clearance and trace width limitations. As the maximum space between pads is 0.26mm (10.2 mil), assuming a trace width of 0.1mm (4 mil) limits the minimum clearance to 0.08mm (3.15 mil).
- **Option 2 (Routing on a different layer using a via):** has specific benefits to the user application. For instance, minimum trace clearance and trace width are higher but require a via on the center pad with specific dimensions. The via diameter must be less than 0.305mm (13.78 mil) to keep the via smaller than the center pad and a minimum drill diameter of 0.1mm (4 mil) can be assumed to avoid manufacturing issues. With this scenario, a minimum annular ring width specification of 0.125mm (5 mil) is required: Annular Ring Width (mm) = (0.305-0.1)/2.

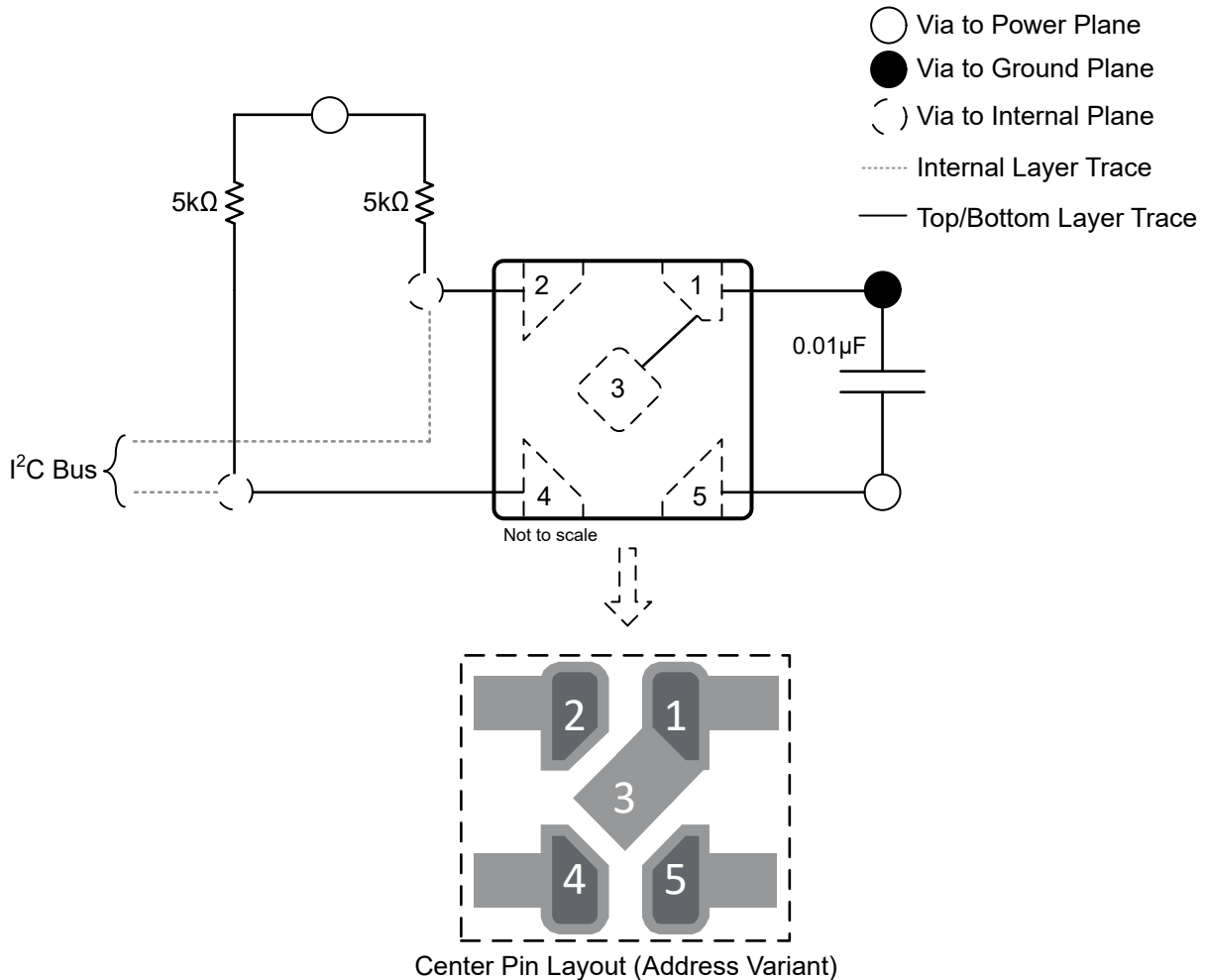
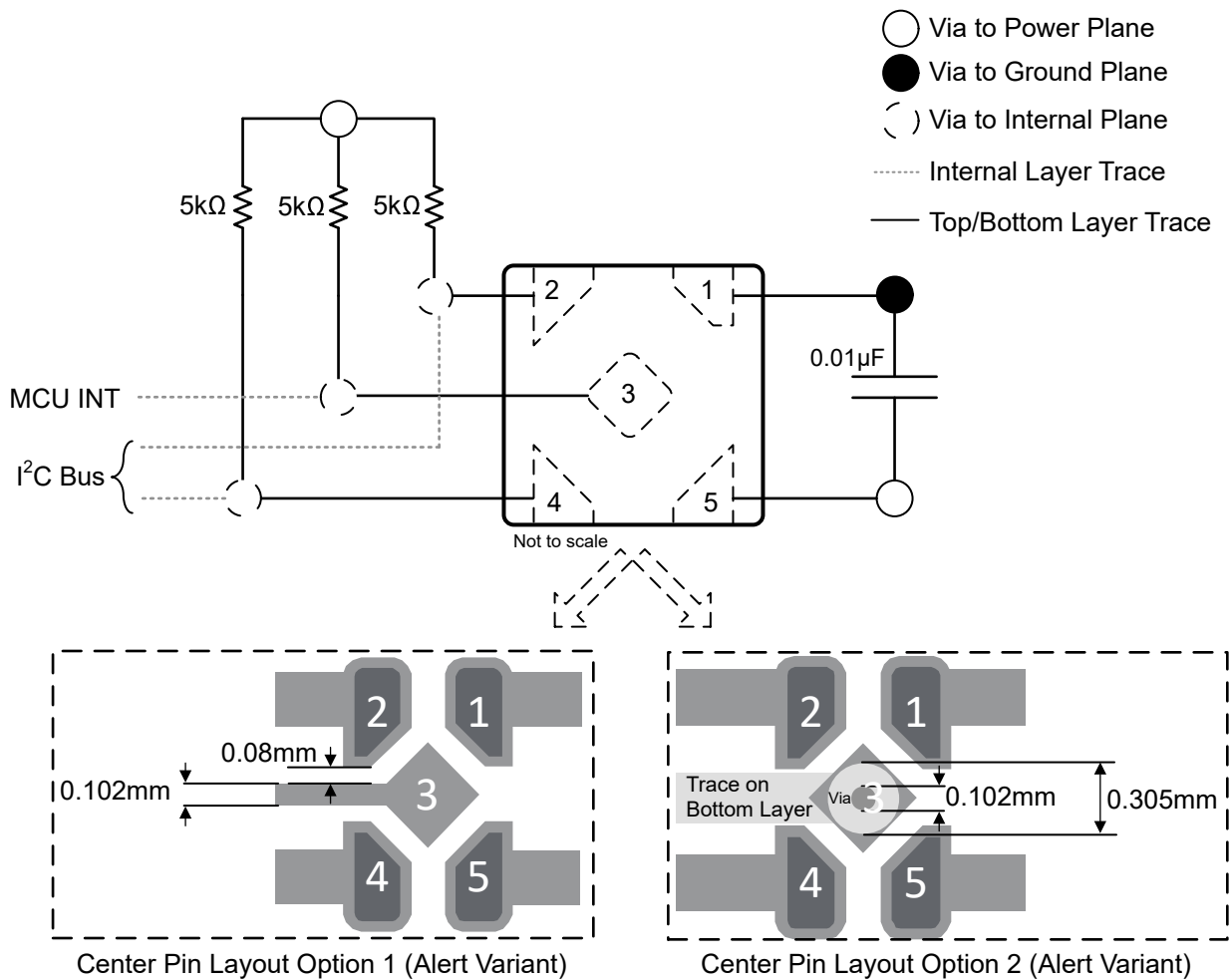
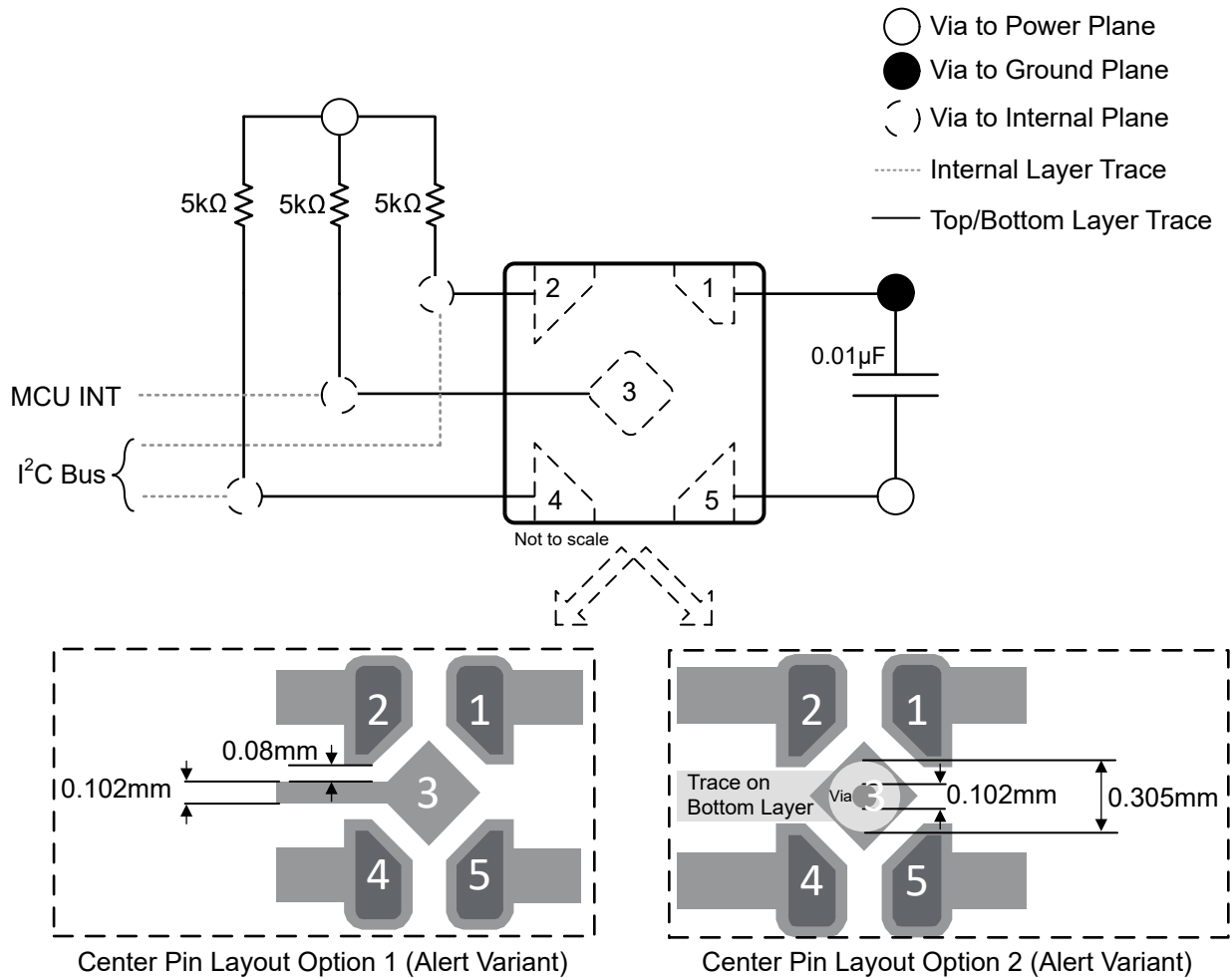

 9-4. ALERT Pin Layout Example

## 10 Device and Documentation Support

TI offers an extensive line of development tools. Tools and software to evaluate the performance of the device, generate code, and develop solutions are listed below.

### 10.1 Documentation Support

#### 10.1.1 Related Documentation

For related documentation see the following:

- Texas Instruments, [TMP102 Low-Power Digital Temperature Sensor With SMBus and Two-Wire Serial Interface in SOT563](#), data sheet
- Texas Instruments, [TMP112x High-Accuracy, Low-Power, Digital Temperature Sensors With SMBus and TwoWire Serial Interface in SOT563](#), data sheet
- Texas Instruments, [TMP1075 Temperature Sensor With I2C and SMBus Interface in Industry Standard LM75 Form Factor and Pinout](#), data sheet
- Texas Instruments, [TMP LM 75 Comparison Common FAQs](#), application note
- Texas Instruments, [TMP110 Evaluation Module](#), EVM user's guide
- Texas Instruments, [Small-Size TMP110 Versus TI's Temperature Sensors](#), product overview

### 10.2 ドキュメントの更新通知を受け取る方法

ドキュメントの更新についての通知を受け取るには、[www.tij.co.jp](http://www.tij.co.jp) のデバイス製品フォルダを開いてください。[通知] をクリックして登録すると、変更されたすべての製品情報に関するダイジェストを毎週受け取ることができます。変更の詳細については、改訂されたドキュメントに含まれている改訂履歴をご覧ください。

### 10.3 サポート・リソース

テキサス・インスツルメンツ E2E™ サポート・フォーラムは、エンジニアが検証済みの回答と設計に関するヒントをエキスパートから迅速かつ直接得ることができる場所です。既存の回答を検索したり、独自の質問をしたりすることで、設計に必要な支援を迅速に得ることができます。

リンクされているコンテンツは、各寄稿者により「現状のまま」提供されるものです。これらはテキサス・インスツルメンツの仕様を構成するものではなく、必ずしもテキサス・インスツルメンツの見解を反映したものではありません。テキサス・インスツルメンツの[使用条件](#)を参照してください。

### 10.4 Trademarks

テキサス・インスツルメンツ E2E™ is a trademark of Texas Instruments.  
すべての商標は、それぞれの所有者に帰属します。

### 10.5 静電気放電に関する注意事項



この IC は、ESD によって破損する可能性があります。テキサス・インスツルメンツは、IC を取り扱う際には常に適切な注意を払うことを推奨します。正しい取り扱いおよび設置手順に従わない場合、デバイスを破損するおそれがあります。

ESD による破損は、わずかな性能低下からデバイスの完全な故障まで多岐にわたります。精密な IC の場合、パラメータがわずかに変化するだけで公表されている仕様から外れる可能性があるため、破損が発生しやすくなっています。

### 10.6 用語集

[テキサス・インスツルメンツ用語集](#) この用語集には、用語や略語の一覧および定義が記載されています。

## 11 Revision History

資料番号末尾の英字は改訂を表しています。その改訂履歴は英語版に準じています。

### Changes from Revision \* (February 2024) to Revision A (July 2024)

Page

- ドキュメント全体にわたって表、図、相互参照の採番方法を更新..... 1

- 
- ドキュメントのステータスを「事前情報」から「量産データ」に変更..... 1
  - Updated empty graphs in the *Typical Characteristics* section..... 8
- 

## 12 メカニカル、パッケージ、および注文情報

以降のページには、メカニカル、パッケージ、および注文に関する情報が記載されています。この情報は指定のデバイスに使用できる最新のデータです。このデータは、予告なく、このドキュメントを改訂せずに変更される場合があります。本データシートのブラウザ版を使用されている場合は、画面左側の説明をご覧ください。





**DPW0005A**

**PACKAGE OUTLINE**

**X2SON - 0.4 mm max height**

PLASTIC SMALL OUTLINE - NO LEAD

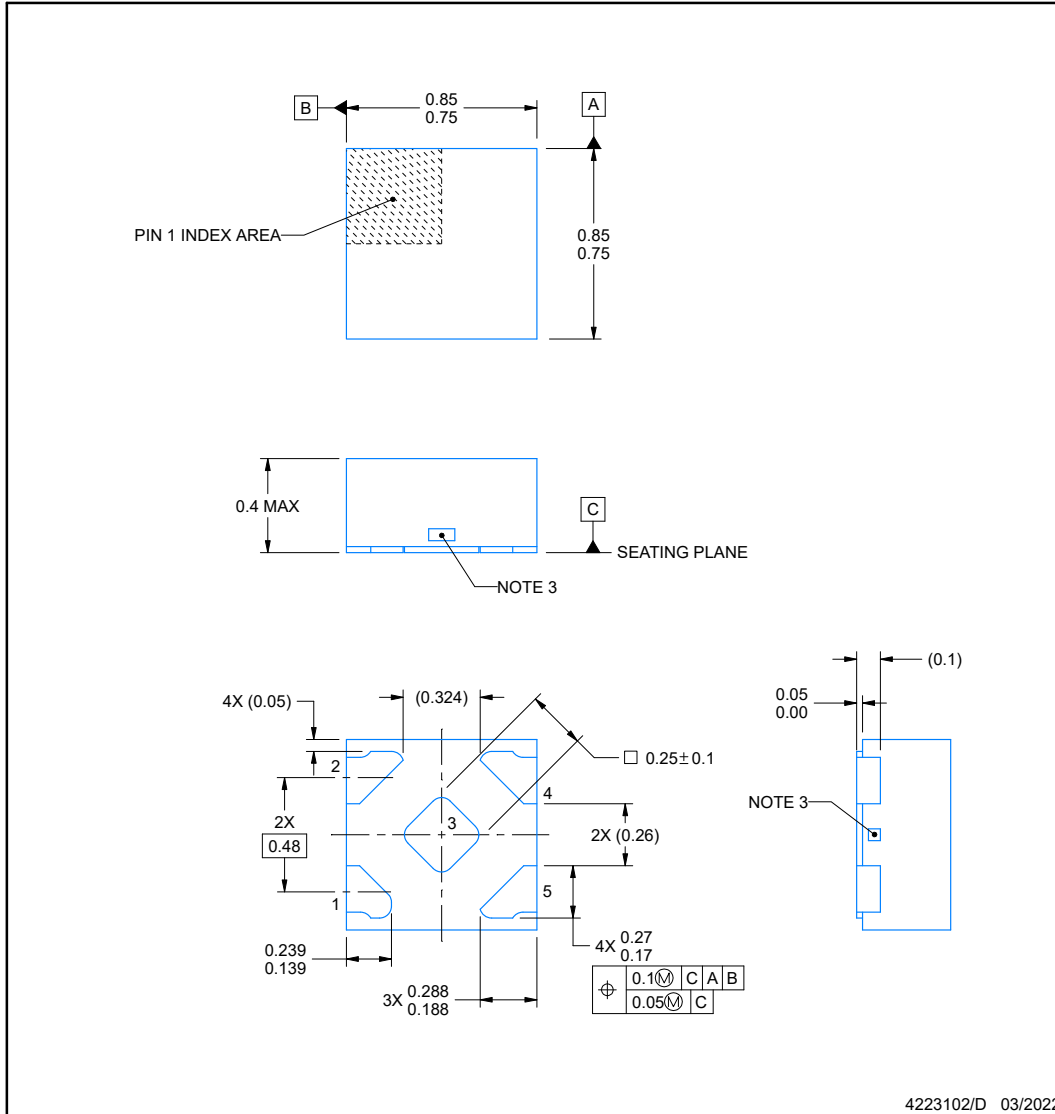

**NOTES:**

1. All linear dimensions are in millimeters. Any dimensions in parenthesis are for reference only. Dimensioning and tolerancing per ASME Y14.5M.
2. This drawing is subject to change without notice.
3. The size and shape of this feature may vary.

**EXAMPLE BOARD LAYOUT**

**DPW0005A**

**X2SON - 0.4 mm max height**

PLASTIC SMALL OUTLINE - NO LEAD

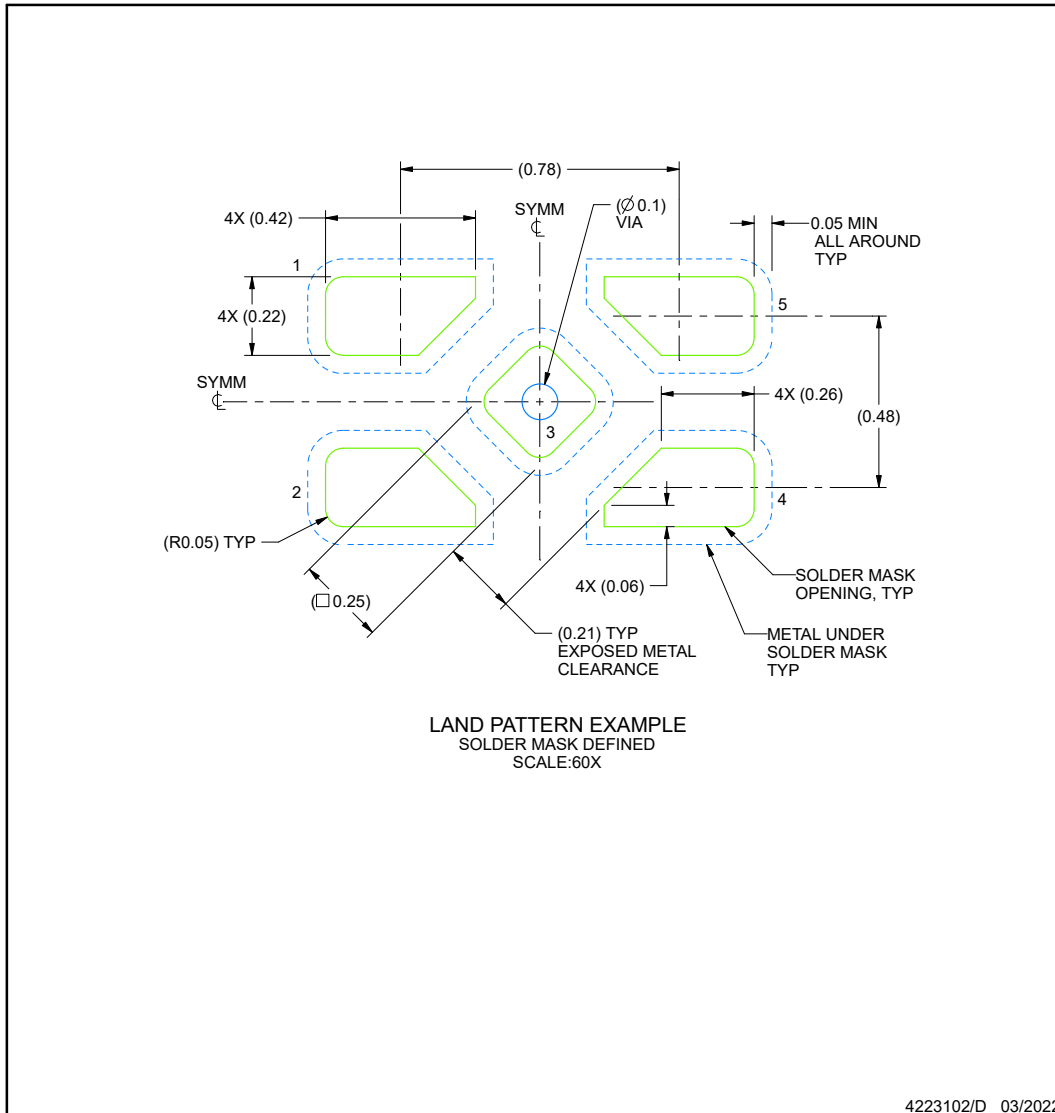

NOTES: (continued)

4. This package is designed to be soldered to a thermal pad on the board. For more information, refer to QFN/SON PCB application note in literature No. SLUA271 ([www.ti.com/lit/sluea271](http://www.ti.com/lit/sluea271)).

## EXAMPLE STENCIL DESIGN

**DPW0005A**

**X2SON - 0.4 mm max height**

PLASTIC SMALL OUTLINE - NO LEAD

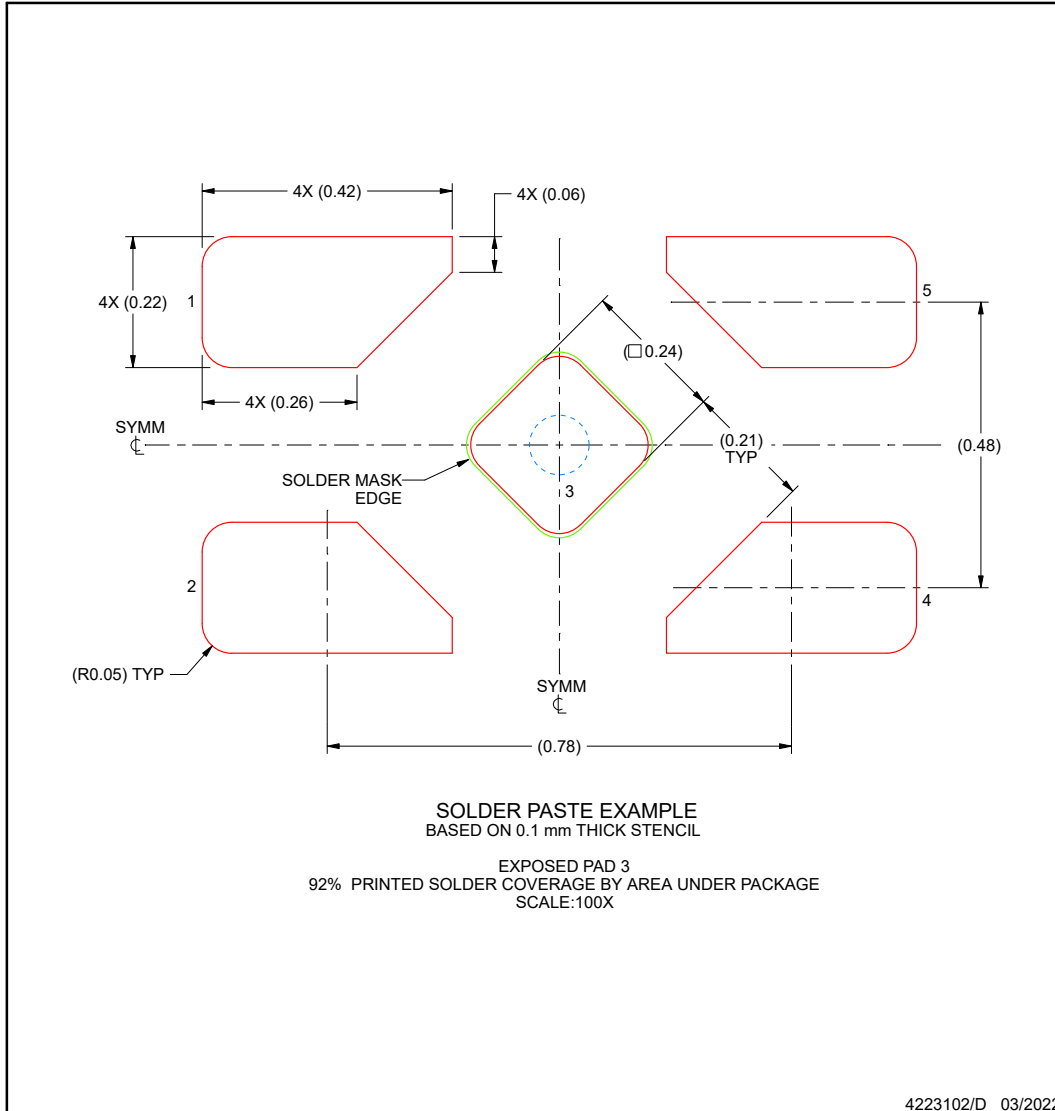

NOTES: (continued)

5. Laser cutting apertures with trapezoidal walls and rounded corners may offer better paste release. IPC-7525 may have alternate design recommendations.

## 重要なお知らせと免責事項

テキサス・インスツルメンツは、技術データと信頼性データ (データシートを含みます)、設計リソース (リファレンス デザインを含みます)、アプリケーションや設計に関する各種アドバイス、Web ツール、安全性情報、その他のリソースを、欠陥が存在する可能性のある「現状のまま」提供しており、商品性および特定目的に対する適合性の黙示保証、第三者の知的財産権の非侵害保証を含むいかなる保証も、明示的または黙示的にかかわらず拒否します。

これらのリソースは、テキサス・インスツルメンツ製品を使用する設計の経験を積んだ開発者への提供を意図したものです。(1) お客様のアプリケーションに適した テキサス・インスツルメンツ製品の選定、(2) お客様のアプリケーションの設計、検証、試験、(3) お客様のアプリケーションに該当する各種規格や、その他のあらゆる安全性、セキュリティ、規制、または他の要件への確実な適合に関する責任を、お客様のみが単独で負うものとします。

上記の各種リソースは、予告なく変更される可能性があります。これらのリソースは、リソースで説明されている テキサス・インスツルメンツ製品を使用するアプリケーションの開発の目的でのみ、テキサス・インスツルメンツはその使用をお客様に許諾します。これらのリソースに関して、他の目的で複製することや掲載することは禁止されています。テキサス・インスツルメンツや第三者の知的財産権のライセンスが付与されている訳ではありません。お客様は、これらのリソースを自身で使用した結果発生するあらゆる申し立て、損害、費用、損失、責任について、テキサス・インスツルメンツおよびその代理人を完全に補償するものとし、テキサス・インスツルメンツは一切の責任を拒否します。

テキサス・インスツルメンツの製品は、[テキサス・インスツルメンツの販売条件](#)、または [ti.com](https://www.ti.com) やかかる テキサス・インスツルメンツ製品の関連資料などのいずれかを通じて提供する適用可能な条項の下で提供されています。テキサス・インスツルメンツがこれらのリソースを提供することは、適用されるテキサス・インスツルメンツの保証または他の保証の放棄の拡大や変更を意味するものではありません。

お客様がいかなる追加条項または代替条項を提案した場合でも、テキサス・インスツルメンツはそれらに異議を唱え、拒否します。

郵送先住所: Texas Instruments, Post Office Box 655303, Dallas, Texas 75265

Copyright © 2024, Texas Instruments Incorporated

## PACKAGING INFORMATION

Orderable Device	Status (1)	Package Type	Package Drawing	Pins	Package Qty	Eco Plan (2)	Lead finish/ Ball material (6)	MSL Peak Temp (3)	Op Temp (°C)	Device Marking (4/5)	Samples
PTMP110D0IDPWR	ACTIVE	X2SON	DPW	5	3000	TBD	Call TI	Call TI	-40 to 125		<a href="#">Samples</a>
TMP110D0IDPWR	ACTIVE	X2SON	DPW	5	3000	RoHS & Green	NIPDAU	Level-1-260C-UNLIM	-40 to 125	Q	<a href="#">Samples</a>
TMP110D1IDPWR	ACTIVE	X2SON	DPW	5	3000	RoHS & Green	NIPDAU	Level-1-260C-UNLIM	-40 to 125	R	<a href="#">Samples</a>
TMP110D2IDPWR	ACTIVE	X2SON	DPW	5	3000	RoHS & Green	NIPDAU	Level-1-260C-UNLIM	-40 to 125	S	<a href="#">Samples</a>
TMP110D3IDPWR	ACTIVE	X2SON	DPW	5	3000	RoHS & Green	NIPDAU	Level-1-260C-UNLIM	-40 to 125	T	<a href="#">Samples</a>
TMP110DIDPWR	ACTIVE	X2SON	DPW	5	3000	RoHS & Green	NIPDAU	Level-1-260C-UNLIM	-40 to 125	A	<a href="#">Samples</a>

(1) The marketing status values are defined as follows:

**ACTIVE:** Product device recommended for new designs.

**LIFEBUY:** TI has announced that the device will be discontinued, and a lifetime-buy period is in effect.

**NRND:** Not recommended for new designs. Device is in production to support existing customers, but TI does not recommend using this part in a new design.

**PREVIEW:** Device has been announced but is not in production. Samples may or may not be available.

**OBSOLETE:** TI has discontinued the production of the device.

(2) **RoHS:** TI defines "RoHS" to mean semiconductor products that are compliant with the current EU RoHS requirements for all 10 RoHS substances, including the requirement that RoHS substance do not exceed 0.1% by weight in homogeneous materials. Where designed to be soldered at high temperatures, "RoHS" products are suitable for use in specified lead-free processes. TI may reference these types of products as "Pb-Free".

**RoHS Exempt:** TI defines "RoHS Exempt" to mean products that contain lead but are compliant with EU RoHS pursuant to a specific EU RoHS exemption.

**Green:** TI defines "Green" to mean the content of Chlorine (Cl) and Bromine (Br) based flame retardants meet JS709B low halogen requirements of <=1000ppm threshold. Antimony trioxide based flame retardants must also meet the <=1000ppm threshold requirement.

(3) MSL, Peak Temp. - The Moisture Sensitivity Level rating according to the JEDEC industry standard classifications, and peak solder temperature.

(4) There may be additional marking, which relates to the logo, the lot trace code information, or the environmental category on the device.

(5) Multiple Device Markings will be inside parentheses. Only one Device Marking contained in parentheses and separated by a "-" will appear on a device. If a line is indented then it is a continuation of the previous line and the two combined represent the entire Device Marking for that device.

(6) Lead finish/Ball material - Orderable Devices may have multiple material finish options. Finish options are separated by a vertical ruled line. Lead finish/Ball material values may wrap to two lines if the finish value exceeds the maximum column width.

**Important Information and Disclaimer:** The information provided on this page represents TI's knowledge and belief as of the date that it is provided. TI bases its knowledge and belief on information provided by third parties, and makes no representation or warranty as to the accuracy of such information. Efforts are underway to better integrate information from third parties. TI has taken and continues to take reasonable steps to provide representative and accurate information but may not have conducted destructive testing or chemical analysis on incoming materials and chemicals. TI and TI suppliers consider certain information to be proprietary, and thus CAS numbers and other limited information may not be available for release.

In no event shall TI's liability arising out of such information exceed the total purchase price of the TI part(s) at issue in this document sold by TI to Customer on an annual basis.

**TAPE AND REEL INFORMATION**

**QUADRANT ASSIGNMENTS FOR PIN 1 ORIENTATION IN TAPE**

\*All dimensions are nominal

Device	Package Type	Package Drawing	Pins	SPQ	Reel Diameter (mm)	Reel Width W1 (mm)	A0 (mm)	B0 (mm)	K0 (mm)	P1 (mm)	W (mm)	Pin1 Quadrant
TMP110D0IDPWR	X2SON	DPW	5	3000	180.0	8.4	0.91	0.91	0.5	2.0	8.0	Q2
TMP110D1IDPWR	X2SON	DPW	5	3000	180.0	8.4	0.91	0.91	0.5	2.0	8.0	Q2
TMP110D2IDPWR	X2SON	DPW	5	3000	180.0	8.4	0.91	0.91	0.5	2.0	8.0	Q2
TMP110D3IDPWR	X2SON	DPW	5	3000	180.0	8.4	0.91	0.91	0.5	2.0	8.0	Q2
TMP110DIDPWR	X2SON	DPW	5	3000	180.0	8.4	0.91	0.91	0.5	2.0	8.0	Q2

**TAPE AND REEL BOX DIMENSIONS**

\*All dimensions are nominal

Device	Package Type	Package Drawing	Pins	SPQ	Length (mm)	Width (mm)	Height (mm)
TMP110D0IDPWR	X2SON	DPW	5	3000	210.0	185.0	35.0
TMP110D1IDPWR	X2SON	DPW	5	3000	210.0	185.0	35.0
TMP110D2IDPWR	X2SON	DPW	5	3000	210.0	185.0	35.0
TMP110D3IDPWR	X2SON	DPW	5	3000	210.0	185.0	35.0
TMP110DIDPWR	X2SON	DPW	5	3000	210.0	185.0	35.0



## GENERIC PACKAGE VIEW

DPW 5

X2SON - 0.4 mm max height

PLASTIC SMALL OUTLINE - NO LEAD



Images above are just a representation of the package family, actual package may vary.  
Refer to the product data sheet for package details.

4211218-3/D

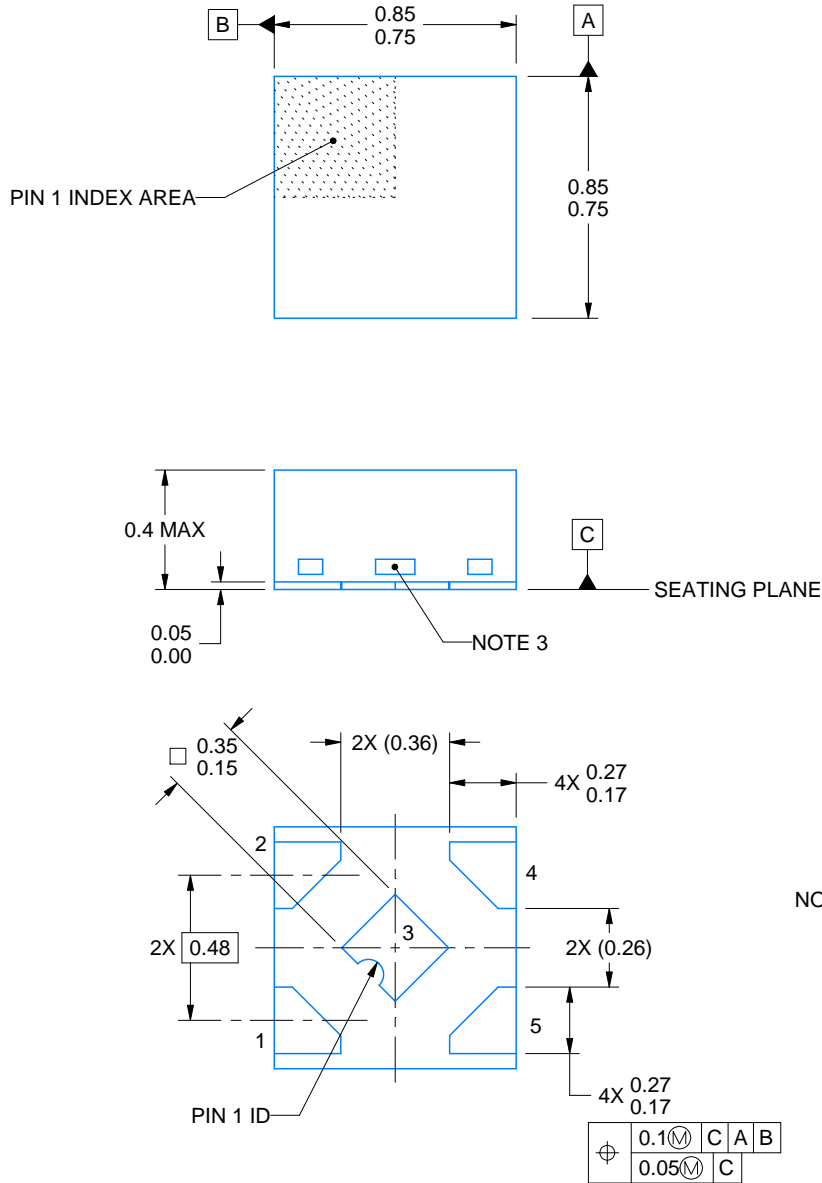
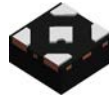

4228233/D 09/2023

NOTES:

1. All linear dimensions are in millimeters. Any dimensions in parenthesis are for reference only. Dimensioning and tolerancing per ASME Y14.5M.
2. This drawing is subject to change without notice.
3. The size and shape of this feature may vary.



# EXAMPLE STENCIL DESIGN

DPW0005B

X2SON - 0.4 mm max height

PLASTIC SMALL OUTLINE - NO LEAD

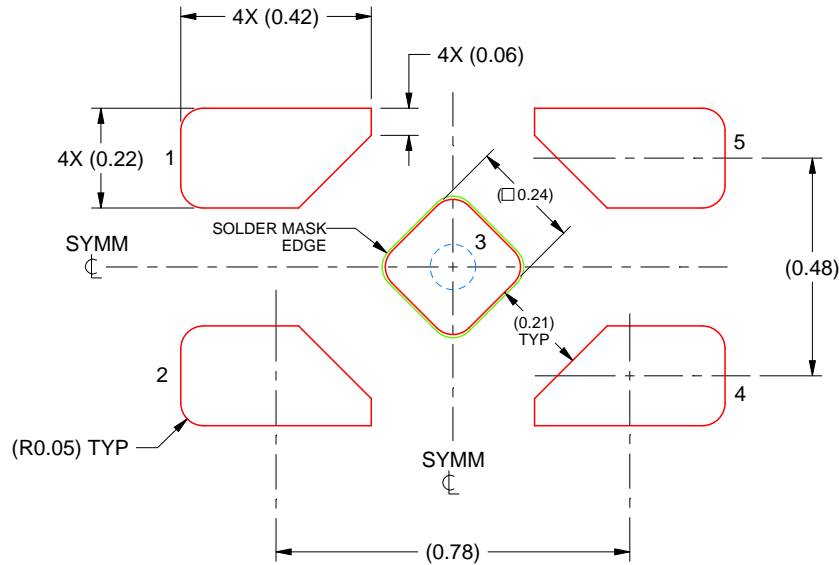

SOLDER PASTE EXAMPLE  
BASED ON 0.1 mm THICK STENCIL

EXPOSED PAD 5  
92% PRINTED SOLDER COVERAGE BY AREA UNDER PACKAGE  
SCALE:60X

4228233/D 09/2023

NOTES: (continued)

5. Laser cutting apertures with trapezoidal walls and rounded corners may offer better paste release. IPC-7525 may have alternate design recommendations.

## 重要なお知らせと免責事項

TI は、技術データと信頼性データ(データシートを含みます)、設計リソース(リファレンス・デザインを含みます)、アプリケーションや設計に関する各種アドバイス、Web ツール、安全性情報、その他のリソースを、欠陥が存在する可能性のある「現状のまま」提供しており、商品性および特定目的に対する適合性の黙示保証、第三者の知的財産権の非侵害保証を含むいかなる保証も、明示的または黙示的にかかわらず拒否します。

これらのリソースは、TI 製品を使用する設計の経験を積んだ開発者への提供を意図したものです。(1) お客様のアプリケーションに適した TI 製品の選定、(2) お客様のアプリケーションの設計、検証、試験、(3) お客様のアプリケーションに該当する各種規格や、その他のあらゆる安全性、セキュリティ、規制、または他の要件への確実な適合に関する責任を、お客様のみが単独で負うものとし、

上記の各種リソースは、予告なく変更される可能性があります。これらのリソースは、リソースで説明されている TI 製品を使用するアプリケーションの開発の目的でのみ、TI はその使用をお客様に許諾します。これらのリソースに関して、他の目的で複製することや掲載することは禁止されています。TI や第三者の知的財産権のライセンスが付与されている訳ではありません。お客様は、これらのリソースを自身で使用した結果発生するあらゆる申し立て、損害、費用、損失、責任について、TI およびその代理人を完全に補償するものとし、TI は一切の責任を拒否します。

TI の製品は、[TI の販売条件](#)、または [ti.com](#) やかかる TI 製品の関連資料などのいずれかを通じて提供する適用可能な条項の下で提供されています。TI がこれらのリソースを提供することは、適用される TI の保証または他の保証の放棄の拡大や変更を意味するものではありません。

お客様がいかなる追加条項または代替条項を提案した場合でも、TI はそれらに異議を唱え、拒否します。

郵送先住所 : Texas Instruments, Post Office Box 655303, Dallas, Texas 75265  
Copyright © 2024, Texas Instruments Incorporated