

TPS37-Q1 車載用、ワイド V_{IN} 、65V デュアル・チャンネル過電圧 / 低電圧 (OV/UV) 検出器、プログラマブル・センス / リセット機能付き

1 特長

- 以下の結果で AEC-Q100 認定済み:
 - デバイス温度グレード 1: $-40^{\circ}\text{C} \sim +125^{\circ}\text{C}$ の動作時周囲温度範囲 T_A
 - デバイス HBM ESD 分類レベル 2
 - デバイス CDM ESD 分類レベル C7B
- 機能安全対応
 - 機能安全システム設計に役立つ資料を利用可能
- 広い電源電圧範囲: 2.7V ~ 65V
- 65V 定格の SENSE および RESET ピン
- 低静止電流: 1 μA (標準値)
- 電圧スレッシュホールドを柔軟にかつ幅広く選択可能
 - 表 11-1
 - 2.7V ~ 36V (誤差 1.5% 以下)
 - 800mV オプション (誤差 1% 以下)
- ヒステリシス内蔵 (V_{HYS})
 - パーセンテージ・オプション: 2% ~ 13% (1% 刻み)
 - 固定オプション: $V_{TH} < 8V = 0.5V, 1V, 1.5V, 2V, 2.5V$
- リセット時間遅延をプログラム可能
 - 10nF = 12.8ms, 10 μF = 12.8s
- 検出時間遅延をプログラム可能
 - 10nF = 1.28ms, 10 μF = 1.28s
- マニュアル・リセット ($\overline{\text{MR}}$) 機能
- 出力ポロジ: オープン・ドレインまたはプッシュプル

2 アプリケーション

- テレマティクス制御ユニット
- 緊急通話システム
- オーディオ・アンプ
- ヘッド・ユニットおよびクラスタ
- センサ・フュージョンおよびカメラ
- ボディ・コントロール・モジュール

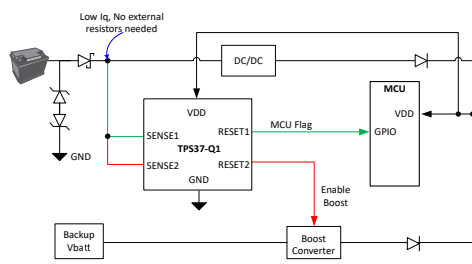

代表的なアプリケーション回路

3 概要

TPS37-Q1 は、 $I_{DD} = 1\mu\text{A}$ 、精度 1%、検出時間が 10 μs と短い 65V 入力電圧検出器です。このデバイスは 12V/24V 車載用バッテリー・システムに直接接続し、過電圧 (OV) または低電圧 (UV) 状態を継続的に監視できます。また、抵抗デバイダを内蔵しているため、ソリューション全体のサイズを最小化できます。コールド・クランク、スタート / ストップ、車の各種バッテリー電圧過渡の影響を受けないように、各種ヒステリシス電圧を選択できます。SENSE ピンに組み込まれたヒステリシスは、電源電圧レール監視中のリセット信号の誤検出を防止します。

VDD ピンと SENSE ピンが独立しているため、信頼性が高い車載用システムが求める冗長性を実現できます。また、SENSE は VDD よりも高い電圧と低い電圧を監視できます。SENSE ピンは高インピーダンス入力であるため、任意で外付け抵抗を使用できます。CTSx および CTRx ピンを使うことで、RESET 信号の立ち上がり / 立ち下がりエッジの遅延を調整できます。また、CTSx は、監視対象の電圧レールの電圧グリッチを無視することで、デバウンスとして機能します。CTRx は、システムを強制的にリセットするための手動リセット ($\overline{\text{MR}}$) として動作します。

TPS37-Q1 は WSON または SOT-23 パッケージで供給されます。WSON パッケージはウェッタブル・フラングを採用しているため、自動光学検査 (AOI) と低解像度 X 線検査を容易に実施できます。IEC60664 のガイドラインに基づいて VDD と GND との間の沿面距離を増やすため、中央パッドはどこにも接続されていません。

製品情報

部品番号	パッケージ ⁽¹⁾	本体サイズ (公称)
TPS37-Q1	WSON (10) (DSK)	2.5mm × 2.5mm
TPS37-Q1	SOT-23 (14) (DYY)	4.1mm × 1.9mm

- (1) パッケージの詳細については、このデータシートの末尾の外形図を参照してください。

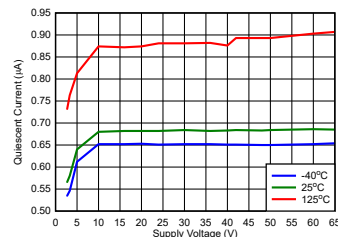

I_{DD} と V_{DD} との代表的な関係



Table of Contents

1 特長	1	8.1 Overview.....	17
2 アプリケーション	1	8.2 Functional Block Diagram.....	17
3 概要	1	8.3 Feature Description.....	18
4 Revision History	2	9 Device Functional Modes	26
5 Device Comparison	3	10 Application and Implementation	27
6 Pin Configuration and Functions	4	10.1 Adjustable Voltage Thresholds.....	27
7 Specifications	6	10.2 Application Information.....	28
7.1 Absolute Maximum Ratings.....	6	10.3 Typical Application.....	28
7.2 ESD Ratings.....	6	10.4 Power Supply Recommendations.....	31
7.3 Recommended Operating Conditions.....	6	10.5 Layout.....	31
7.4 Thermal Information.....	6	11 Device and Documentation Support	34
7.5 Electrical Characteristics.....	7	11.1 Device Nomenclature.....	34
7.6 Timing Requirements.....	9	11.2 サポート・リソース.....	35
7.7 Timing Diagrams.....	10	11.3 Trademarks.....	35
7.8 Typical Characteristics.....	13	11.4 静電気放電に関する注意事項.....	35
8 Detailed Description	17	11.5 用語集.....	35

4 Revision History

資料番号末尾の英字は改訂を表しています。その改訂履歴は英語版に準じています。

Changes from Revision D (July 2023) to Revision E (August 2023)	Page
• 機能安全に関する記述を追加し、ラッチ機能を削除.....	1
• Add Vhyst and accuracy diagram.....	10
• Added CTS and CTR value plots.....	13
• Fixed output topology.....	22
• Corrected CTR to CTS on EQ.....	24

Changes from Revision C (December 2021) to Revision D (July 2023)	Page
• 全体を通して、DYY パッケージの製品プレビューを削除.....	1

Changes from Revision B (September 2021) to Revision C (December 2021)	Page
• 「事前情報」から「量産データ」のリリースに変更.....	1

5 Device Comparison

Contact TI sales representatives or consult TI's E2E forum for details and availability; minimum order quantities may apply.

Voltage Threshold
Hysteresis

CH 1
CH 2
CH 1
CH 2

TPS37 X **XX XX** **X X** **XXX** **R-Q1**

Topology		
Suffix	CH1	CH2
A	OV OD L	UV OD L
B	OV PP H	UV OD L
C	OV OD L	UV OD H
D	OV PP H	UV OD H
E	OV OD H	UV OD H
F	OV OD H	UV OD L
G	OV PP L	UV OD H
H	OV PP L	UV OD L

Threshold Voltage							
100mV steps				400mV steps			
Suffix	VIT	Suffix	VIT	Suffix	VIT	Suffix	VIT
01	800mV	70	7.0V	A0	10.4V	D0	20.5V
27	2.7V	71	7.1V	A1	10.8V	D1	21.0V
28	2.8V	72	7.2V	A2	11.2V	D2	21.5V
29	2.9V	73	7.3V	A3	11.6V	D3	22.0V
30	3.0V	74	7.4V	A4	12.0V	D4	22.5V
31	3.1V	75	7.5V	A5	12.4V	D5	23.0V
32	3.2V	76	7.6V	A6	12.8V	D6	23.5V
33	3.3V	77	7.7V	A7	13.2V	D7	24.0V
34	3.4V	78	7.8V	A8	13.6V	D8	24.5V
35	3.5V	79	7.9V	A9	14.0V	D9	25.0V
36	3.6V	80	8.0V	B0	14.4V	E0	25.5V
37	3.7V	81	8.1V	B1	14.8V	E1	26.0V
38	3.8V	82	8.2V	B2	15.2V	E2	26.5V
39	3.9V	83	8.3V	B3	15.6V	E3	27.0V
40	4.0V	84	8.4V	B4	16.0V	E4	27.5V
41	4.1V	85	8.5V	B5	16.4V	E5	28.0V
42	4.2V	86	8.6V	B6	16.8V	E6	28.5V
43	4.3V	87	8.7V	B7	17.2V	E7	29.0V
44	4.4V	88	8.8V	B8	17.6V	E8	29.5V
45	4.5V	89	8.9V	B9	18.0V	E9	30.0V
46	4.6V	90	9.0V	C0	18.4V		
47	4.7V	91	9.1V	C1	18.8V		
48	4.8V	92	9.2V	C2	19.2V		
49	4.9V	93	9.3V	C3	19.6V		
50	5.0V	94	9.4V	C4	20.0V		
51	5.1V	95	9.5V				
52	5.2V	96	9.6V				
53	5.3V	97	9.7V				
54	5.4V	98	9.8V				
55	5.5V	99	9.9V				
56	5.6V	00	10.0V				
57	5.7V						
58	5.8V						
59	5.9V						
60	6.0V						
61	6.1V						
62	6.2V						
63	6.3V						
64	6.4V						
65	6.5V						
66	6.6V						
67	6.7V						
68	6.8V						
69	6.9V						

Hysteresis	
Suffix	CH1
2	2%
3	3%
4	4%
5	5%
6	6%
7	7%
8	8%
9	9%
A	10%
B	11%
C	12%
D	13%
E	0.5V
F	1V
G	1.5V
H	2V
I	2.5V

Package	
Suffix	Name
DSK	WSON
DYY	SOT-23

Reel	
Suffix	Name
R	Large

Rating	
Suffix	Name
Q1	AUTO
	INDUSTRIAL

1. Sense logic: OV = overvoltage; UV = undervoltage
2. Reset topology: PP = Push-Pull; OD = Open-Drain
3. Reset logic: L = Active-Low; H = Active-High
4. A to I hysteresis options are only available for 2.7 V to 8 V threshold options

6 Pin Configuration and Functions

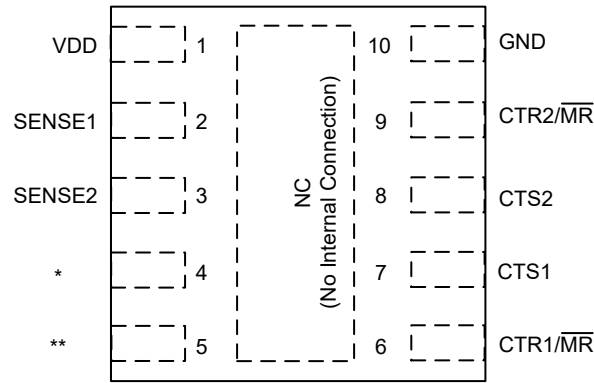

* Pin 4 Options

1. $\overline{\text{RESET1_OV}}\#\#$
2. $\text{RESET1_OV}\#\#$

** Pin 5 Options

1. $\overline{\text{RESET2_UVOD}}$
2. RESET2_UVOD

\#\# OD (Open-Drain) or PP (Push-Pull)

**6-1. DSK Package,
10-Pin WSON,
TPS37-Q1 (Top View)**

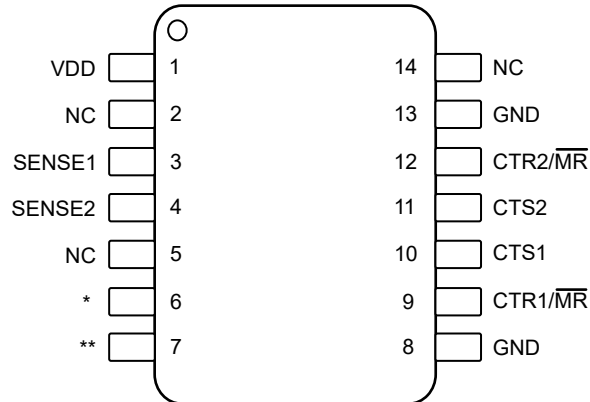

* Pin 6 Options

1. $\overline{\text{RESET1_OV}}\#\#$
2. $\text{RESET1_OV}\#\#$

** Pin 7 Options

1. $\overline{\text{RESET2_UVOD}}$
2. RESET2_UVOD

\#\# OD (Open-Drain) or PP (Push-Pull)

**6-2. DYY Package,
14-Pin SOT-23,
TPS37-Q1 (Top View)**

表 6-1. Pin Functions

PIN NAME	WSON (DSK)	SOT23 (DYY)	I/O	DESCRIPTION
	PIN NUM.	PIN NUM.		
VDD	1	1	I	Input Supply Voltage: Bypass with a 0.1 μ F capacitor to GND.
SENSE1	2	3	I	This pin is connected to the voltage that will be monitored for fixed variants or to a resistor divider for the adjustable variant. When the voltage on SENSE1 pin transitions above the upper threshold voltage of V_{IT+} , $\overline{\text{RESET1}}/\text{RESET1}$ asserts after the sense time delay, set by CTS1. When the voltage on the SENSE1 pin transitions below the upper threshold voltage of $V_{IT+} - V_{HYS}$, $\overline{\text{RESET1}}/\text{RESET1}$ deasserts after the reset time delay, set by CTR1. For noisy applications, placing a 10 nF to 100 nF ceramic capacitor close to this pin may be needed for optimum performance.
SENSE2	3	4	I	This pin is connected to the voltage that will be monitored for fixed variants or to a resistor divider for the adjustable variant. When the voltage on SENSE2 pin transitions below the lower threshold voltage of V_{IT-} , $\overline{\text{RESET2}}/\text{RESET2}$ asserts after the sense time delay, set by CTS2. When the voltage on the SENSE2 pin transitions above the lower threshold voltage of $V_{IT-} + V_{HYS}$, $\overline{\text{RESET2}}/\text{RESET2}$ deasserts after the reset time delay, set by CTR2. For noisy applications, placing a 10 nF to 100 nF ceramic capacitor close to this pin may be needed for optimum performance.
$\overline{\text{RESET1}}/\text{RESET1}$	4	6	O	Output Reset Signal For Channel 1: See セクション 5 for output topology options. $\overline{\text{RESET1}}/\text{RESET1}$ asserts when SENSE1 rises outside of the upper voltage threshold. $\overline{\text{RESET1}}/\text{RESET1}$ remains asserted for the reset time delay period after SENSE1 transitions out of an overvoltage (OV) fault condition. For active low open-drain reset output, an external pullup resistor is required. Do not place external pullup resistors on push-pull outputs. Reset output signal for: SENSE1 Sensing Topology: Overvoltage (OV) Output topology: Open Drain or Push Pull, Active Low or Active High
$\overline{\text{RESET2}}/\text{RESET2}$	5	7	O	Output Reset Signal For Channel 2: See セクション 5 for output topology options. $\overline{\text{RESET2}}/\text{RESET2}$ asserts when SENSE2 falls outside of the lower voltage threshold. $\overline{\text{RESET2}}/\text{RESET2}$ remains asserted for the reset time delay period after SENSE2 transitions out of an undervoltage (UV) fault condition. For active low open-drain reset output, an external pullup resistor is required. Reset output signal for: SENSE2 Sensing Topology: Undervoltage (UV) Output topology: Open Drain, Active Low or Active High
CTR1/ $\overline{\text{MR}}$	6	9	-	Channel 1 RESET Time Delay: User-programmable reset time delay for $\overline{\text{RESET1}}/\text{RESET1}$. Connect an external capacitor for adjustable time delay or leave the pin floating for the shortest delay. Manual Reset: If this pin is driven low, the $\overline{\text{RESET1}}/\text{RESET1}$ output will reset and become asserted. The pin can be left floating or be connected to a capacitor. This pin should not be driven high.
CTR2/ $\overline{\text{MR}}$	9	12	-	Channel 2 RESET Time Delay: User-programmable reset time delay for $\overline{\text{RESET2}}/\text{RESET2}$. Connect an external capacitor for adjustable time delay or leave the pin floating for the shortest delay. Manual Reset: If this pin is driven low, the $\overline{\text{RESET2}}/\text{RESET2}$ output will reset and become asserted. The pin can be left floating or be connected to a capacitor. This pin should not be driven high.
GND	10	8, 13	-	Ground. All GND pins must be electrically connected to the board ground.
NC	PAD	2, 5, 14	-	The PAD for the DSK package is not internally connected, the PAD can be connected to GND or be left floating. For the DYY package, NC stands for "No Connect". The pins are to be left floating.
CTS1	7	10	O	Channel 1 SENSE Time Delay: Capacitor programmable sense delay: CTS1 pin offers a user-adjustable sense delay time when asserting a reset condition. Connecting this pin to a ground-referenced capacitor sets the $\overline{\text{RESET1}}/\text{RESET1}$ delay time to assert.
CTS2	8	11	O	Channel 2 SENSE Time Delay: Capacitor programmable sense delay: CTS2 pin offers a user-adjustable sense delay time when asserting a reset condition. Connecting this pin to a ground-referenced capacitor sets the $\overline{\text{RESET2}}/\text{RESET2}$ delay time to assert.

7 Specifications

7.1 Absolute Maximum Ratings

over operating free-air temperature range, unless otherwise noted ⁽¹⁾

		MIN	MAX	UNIT
Voltage	VDD, V _{SENSE1} , V _{SENSE2} , V _{RESET1} , V _{RESET2} , V _{RESET1} , V _{RESET2}	-0.3	70	V
Voltage	V _{CTS1} , V _{CTS2} , V _{CTR1} , V _{CTR2}	-0.3	6	V
Current	I _{RESET1} , I _{RESET2} , I _{RESET1} , I _{RESET2}		10	mA
Temperature ⁽²⁾	Operating junction temperature, T _J	-40	150	°C
Temperature ⁽²⁾	Operating Ambient temperature, T _A	-40	150	°C
Temperature ⁽²⁾	Storage, T _{stg}	-65	150	°C

- (1) Stresses beyond those listed under Absolute Maximum Ratings may cause permanent damage to the device. These are stress ratings only, which do not imply functional operation of the device at these or any other conditions beyond those indicated under Recommended Operating Conditions. Exposure to absolute-maximum-rated conditions for extended periods may affect device reliability.
- (2) As a result of the low dissipated power in this device, it is assumed that T_J = T_A.

7.2 ESD Ratings

			VALUE	UNIT
V _(ESD)	Electrostatic discharge	Human body model (HBM), per AEC Q100-002 ⁽¹⁾	±2000	V
		Charged device model (CDM), per AEC Q100-011	±750	

- (1) AEC Q100-002 indicates that HBM stressing shall be in accordance with the ANSI/ESDA/JEDEC JS-001 specification.

7.3 Recommended Operating Conditions

over operating free-air temperature range (unless otherwise noted)

		MIN	NOM	MAX	UNIT
Voltage	V _{DD}	2.7		65	V
Voltage	V _{SENSE1} , V _{SENSE2} , V _{RESET1} , V _{RESET2} , V _{RESET1} , V _{RESET2}	0		65	V
Voltage	V _{CTS1} , V _{CTS2} , V _{CTR1} , V _{CTR2}	0		5.5	V
Current	I _{RESET1} , I _{RESET2} , I _{RESET1} , I _{RESET2}	0		±5	mA
T _J	Junction temperature (free air temperature)	-40		125	°C

7.4 Thermal Information

THERMAL METRIC ⁽¹⁾		TPS37-Q1		UNIT
		DSK	DYY	
		10-PIN	14-PIN	
R _{θJA}	Junction-to-ambient thermal resistance	87.4	131.5	°C/W
R _{θJC(top)}	Junction-to-case (top) thermal resistance	76.3	61.1	°C/W
R _{θJB}	Junction-to-board thermal resistance	54.2	56.6	°C/W
ψ _{JT}	Junction-to-top characterization parameter	4.8	3.4	°C/W
ψ _{JB}	Junction-to-board characterization parameter	54.2	56.5	°C/W
R _{θJC(bot)}	Junction-to-case (bottom) thermal resistance	34.8	N/A	°C/W

- (1) For more information about traditional and new thermal metrics, see the [Semiconductor and IC Package Thermal Metrics](#) application report.

7.5 Electrical Characteristics

At $V_{DD(MIN)} \leq V_{DD} \leq V_{DD(MAX)}$, $CTR1/M\bar{R} = CTR2/M\bar{R} = CTS1 = CTS2 = \text{open}$, output reset pull-up resistor $R_{PU} = 10 \text{ k}\Omega$, voltage $V_{PU} = 5.5 \text{ V}$, and load $C_{LOAD} = 10 \text{ pF}$. The operating free-air temperature range $T_A = -40^\circ\text{C}$ to 125°C , unless otherwise noted. Typical values are at $T_A = 25^\circ\text{C}$ and $V_{DD} = 16 \text{ V}$ and $V_{IT} = 6.5 \text{ V}$ (V_{IT} refers to V_{ITN} or V_{ITP}).

PARAMETER	TEST CONDITIONS	MIN	TYP	MAX	UNIT
VDD					
V_{DD}	Supply Voltage	2.7		65	V
UVLO ⁽¹⁾	Undervoltage Lockout	V_{DD} Falling below $V_{DD(MIN)}$		2.7	V
V_{POR}	Power on Reset Voltage ⁽²⁾ RESET, Active Low (Open-Drain, Push-Pull)	$V_{OL(MAX)} = 300 \text{ mV}$ $I_{OUT(SINK)} = 15 \mu\text{A}$		1.4	V
V_{POR}	Power on Reset Voltage ⁽²⁾ RESET, Active High (Push-Pull)	$V_{OH(MIN)} = 0.8 \times V_{DD}$ $I_{OUT(SOURCE)} = 15 \mu\text{A}$		1.4	V
I_{DD}	Supply current into VDD pin	$V_{IT} = 800 \text{ mV}$ $V_{DD(MIN)} \leq V_{DD} \leq V_{DD(MAX)}$		1	μA
		$V_{IT} = 2.7 \text{ V to } 36 \text{ V}$ $V_{DD(MIN)} \leq V_{DD} \leq V_{DD(MAX)}$		1	μA
SENSE (Input)					
I_{SENSE}	Input current (SENSE1, SENSE2)	$V_{IT} = 800 \text{ mV}$		100	nA
I_{SENSE}	Input current (SENSE1, SENSE2)	$V_{IT} < 10 \text{ V}$		0.8	μA
I_{SENSE}	Input current (SENSE1, SENSE2)	$10 \text{ V} < V_{IT} < 26 \text{ V}$		1.2	μA
I_{SENSE}	Input current (SENSE1, SENSE2)	$V_{IT} > 26 \text{ V}$		2	μA
V_{ITN}	Input Threshold Negative (Undervoltage)	$V_{IT} = 2.7 \text{ V to } 36 \text{ V}$		-1.5	%
		$V_{IT} = 800 \text{ mV} \text{ } ^{(3)}$		0.792	0.800
V_{ITP}	Input Threshold Positive (Overvoltage)	$V_{IT} = 2.7 \text{ V to } 36 \text{ V}$		-1.5	%
		$V_{IT} = 800 \text{ mV} \text{ } ^{(3)}$		0.792	0.800
V_{HYS}	Hysteresis Accuracy ⁽⁴⁾	$V_{IT} = 0.8 \text{ V and } 2.7 \text{ V to } 36 \text{ V}$ V_{HYS} Range = 2% to 13% (1% step)		-1.5	%
		$V_{IT} = 2.7 \text{ V to } 8 \text{ V}$ $V_{HYS} = 0.5 \text{ V, } 1 \text{ V, } 1.5 \text{ V, } 2 \text{ V, } 2.5 \text{ V}$ $(V_{ITP} - V_{HYS}) \geq 2.4 \text{ V, OV Only}$		-1.5	1.5
RESET (Output)					
$I_{IKG(OD)}$	Open-Drain leakage (RESET1, RESET2)	$V_{RESET} = 5.5 \text{ V}$ $V_{ITN} < V_{SENSE} < V_{ITP}$		300	nA
		$V_{RESET} = 65 \text{ V}$ $V_{ITN} < V_{SENSE} < V_{ITP}$		300	nA
$V_{OL} \text{ } ^{(5)}$	Low level output voltage	$2.7 \text{ V} \leq V_{DD} \leq 65 \text{ V}$ $I_{RESET} = 5 \text{ mA}$		300	mV
V_{OH_DO}	High level output voltage dropout ($V_{DD} - V_{OH} = V_{OH_DO}$) (Push-Pull only)	$2.7 \text{ V} \leq V_{DD} \leq 65 \text{ V}$ $I_{RESET} = 500 \mu\text{A}$		100	mV
$V_{OH} \text{ } ^{(5)}$	High level output voltage (Push-Pull only)	$2.7 \text{ V} \leq V_{DD} \leq 65 \text{ V}$ $I_{RESET} = 5 \text{ mA}$		$0.8V_{DD}$	V

7.5 Electrical Characteristics (continued)

At $V_{DD(MIN)} \leq V_{DD} \leq V_{DD(MAX)}$, $CTR1/\overline{MR} = CTR2/\overline{MR} = CTS1 = CTS2 = \text{open}$, output reset pull-up resistor $R_{PU} = 10 \text{ k}\Omega$, voltage $V_{PU} = 5.5 \text{ V}$, and load $C_{LOAD} = 10 \text{ pF}$. The operating free-air temperature range $T_A = -40^\circ\text{C}$ to 125°C , unless otherwise noted. Typical values are at $T_A = 25^\circ\text{C}$ and $V_{DD} = 16 \text{ V}$ and $V_{IT} = 6.5 \text{ V}$ (V_{IT} refers to V_{ITN} or V_{ITP}).

PARAMETER		TEST CONDITIONS	MIN	TYP	MAX	UNIT
Capacitor Timing (CTS, CTR)						
R_{CTR}	Internal resistance ($CTR1 / \overline{MR}$, $CTR2 / \overline{MR}$)		877	1000	1147	Kohms
R_{CTS}	Internal resistance ($CTS1$, $CTS2$)		88	100	122	Kohms
Manual Reset (\overline{MR})						
$V_{\overline{MR_IH}}$	$CTR1 / \overline{MR}$ and $CTR2 / \overline{MR}$ pin logic high input	$V_{DD} = 2.7 \text{ V}$	2200			mV
$V_{\overline{MR_IH}}$	$CTR1 / \overline{MR}$ and $CTR2 / \overline{MR}$ pin logic high input	$V_{DD} = 65 \text{ V}$	2500			mV
$V_{\overline{MR_IL}}$	$CTR1 / \overline{MR}$ and $CTR2 / \overline{MR}$ pin logic low input	$V_{DD} = 2.7 \text{ V}$			1300	mV
$V_{\overline{MR_IL}}$	$CTR1 / \overline{MR}$ and $CTR2 / \overline{MR}$ pin logic low input	$V_{DD} = 65 \text{ V}$			1300	mV

- (1) When V_{DD} voltage falls below UVLO, reset is asserted for Output 1 and Output 2. V_{DD} slew rate $\leq 100 \text{ mV} / \mu\text{s}$
- (2) V_{POR} is the minimum V_{DD} voltage for a controlled output state. Below V_{POR} , the output cannot be determined. $V_{DD} \text{ dv/dt} \leq 100 \text{ mV}/\mu\text{s}$
- (3) For adjustable voltage guidelines and resistor selection refer to **Adjustable Voltage Thresholds** in **Application and Implementation section**
- (4) Hysteresis is with respect to V_{ITP} and V_{ITN} voltage threshold. V_{ITP} has negative hysteresis and V_{ITN} has positive hysteresis.
- (5) For V_{OH} and V_{OL} relation to output variants refer to **Timing Figures after the Timing Requirement Table**

7.6 Timing Requirements

At $V_{DD(MIN)} \leq V_{DD} \leq V_{DD(MAX)}$, $CTR1/MR = CTR2/MR = CTS1 = CTS2 = \text{open}$ ⁽¹⁾, output reset pull-up resistor $R_{PU} = 10 \text{ k}\Omega$, voltage $V_{PU} = 5.5\text{V}$, and $C_{LOAD} = 10 \text{ pF}$. V_{DD} and $SENSE$ slew rate = $1\text{V} / \mu\text{s}$. The operating free-air temperature range $T_A = -40^\circ\text{C}$ to 125°C , unless otherwise noted. Typical values are at $T_A = 25^\circ\text{C}$ and $V_{DD} = 16 \text{ V}$ and $V_{IT} = 6.5 \text{ V}$ (V_{IT} refers to either V_{ITN} or V_{ITP}).

PARAMETER	TEST CONDITIONS	MIN	TYP	MAX	UNIT	
Common timing parameters						
t_{CTR}	Reset release time delay (CTR1/MR, CTR2/MR) ⁽²⁾	$V_{IT} = 2.7 \text{ V to } 36 \text{ V}$ $C_{CTR1} = C_{CTR2} = \text{Open}$ 20% Overdrive from Hysteresis			100	μs
		$V_{IT} = 800 \text{ mV}$ $C_{CTR1} = C_{CTR2} = \text{Open}$ 20% Overdrive from Hysteresis			40	μs
t_{CTS}	Sense detect time delay (CTS1, CTS2) ⁽³⁾	$V_{IT} = 2.7 \text{ V to } 36 \text{ V}$ $C_{CTS1} = C_{CTS2} = \text{Open}$ 20% Overdrive from V_{IT}		34	90	μs
		$V_{IT} = 800 \text{ mV}$ $C_{CTS1} = C_{CTS2} = \text{Open}$ 20% Overdrive from V_{IT}		8	17	μs
t_{SD}	Startup Delay ⁽⁴⁾	$C_{CTR1/MR} = C_{CTR2/MR} = \text{Open}$			2	ms

- (1) C_{CTR1} = Reset delay channel 1, C_{CTR2} = Reset delay channel 2,
 C_{CTS1} = Sense delay channel 1, C_{CTS2} = Sense delay channel 2
- (2) **CTR Reset detect time delay:**
 Overvoltage active-LOW output is measure from $V_{ITP-HYS}$ to V_{OH}
 Undervoltage active-LOW output is measure from $V_{ITN+HYS}$ to V_{OH}
 Overvoltage active-HIGH output is measure from $V_{ITP-HYS}$ to V_{OL}
 Undervoltage active-HIGH output is measure from $V_{ITN+HYS}$ to V_{OL}
- (3) **CTS Sense detect time delay:**
 Active-low output is measure from V_{IT} to V_{OL} (or V_{Pullup})
 Active-high output is measured from V_{IT} to V_{OH}
 V_{IT} refers to either V_{ITN} or V_{ITP}
- (4) During the power-on sequence, V_{DD} must be at or above $V_{DD(MIN)}$ for at least t_{SD} before the output is in the correct state based on V_{SENSE} .
 t_{SD} time includes the propagation delay ($C_{CTR1} = C_{CTR2} = \text{Open}$). Capacitor in C_{CTR1} or C_{CTR2} will add time to t_{SD} .

7.7 Timing Diagrams

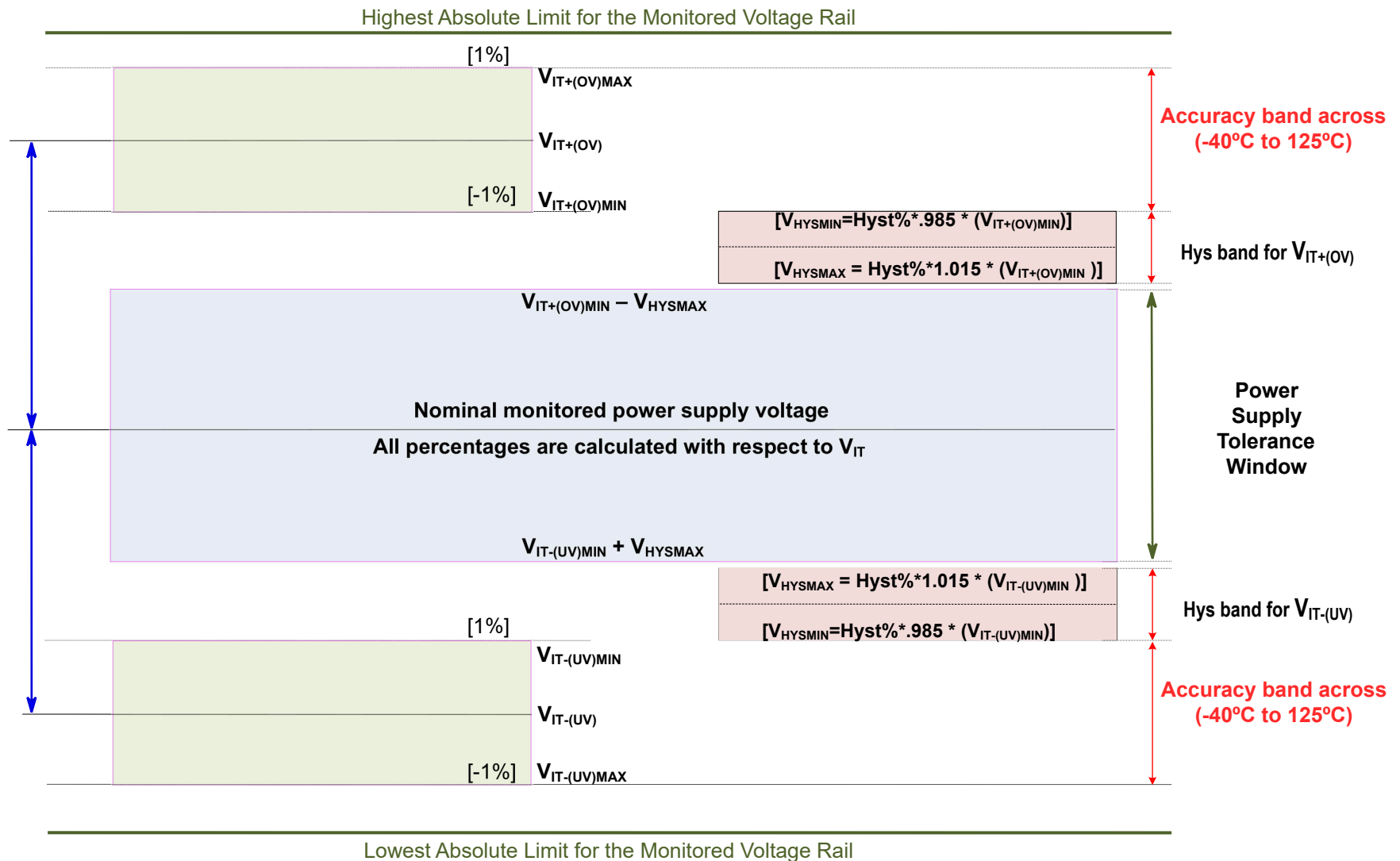

7-1. Voltage Threshold and Hysteresis Accuracy

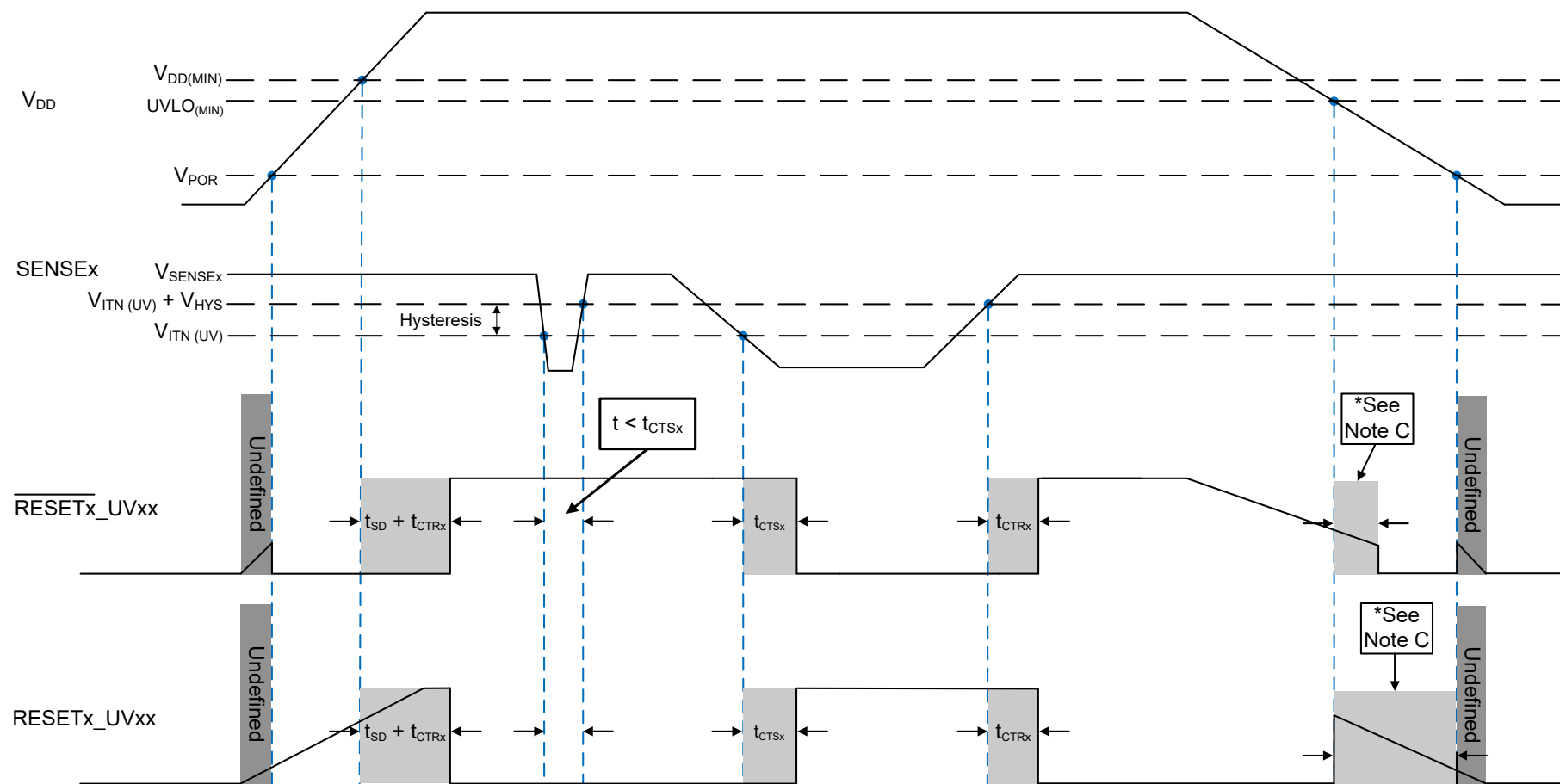

- For open-drain output option, the timing diagram assumes the $\overline{\text{RESET}}_x\text{UVOD}$ / $\text{RESET}_x\text{UVOD}$ pin is connected via an external pull-up resistor to VDD.
- Be advised that [Figure 7-2](#) shows the VDD falling slew rate is slow or the VDD decay time is much larger than the propagation detect delay (t_{CTRx}) time.
- $\overline{\text{RESET}}_x\text{UVxx}$ / $\text{RESET}_x\text{UVxx}$ is asserted when VDD goes below the UVLO_(MIN) threshold after the time delay, t_{CTRx} , is reached.

Figure 7-2. SENSE_x Undervoltage (UV) Timing Diagram

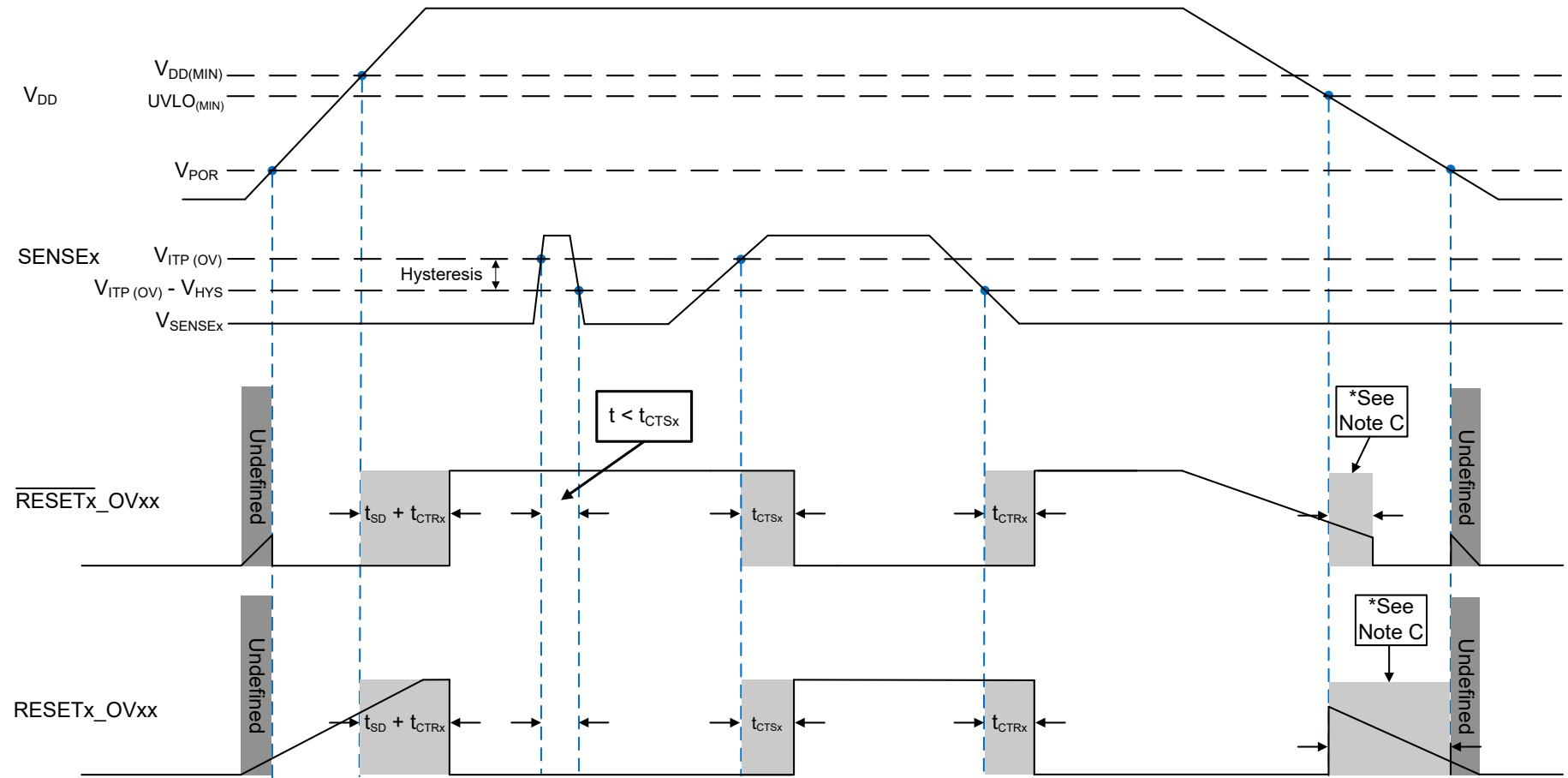

- A. For open-drain output option, the timing diagram assumes the $\overline{\text{RESET}}_x\text{OVOD}$ / $\text{RESET}_x\text{OVOD}$ pin is connected via an external pull-up resistor to VDD.
- B. Be advised that [Figure 7-3](#) shows the VDD falling slew rate is slow or the VDD decay time is much larger than the propagation detect delay (t_{CTRx}) time.
- C. $\overline{\text{RESET}}_x\text{OVxx}$ / $\text{RESET}_x\text{OVxx}$ is asserted when VDD goes below the UVLO_(MIN) threshold after the time delay, t_{CTRx}, is reached.

Figure 7-3. SENSE_x Overvoltage (OV) Timing Diagram

7.8 Typical Characteristics

Typical characteristics show the typical performance of the TPS37-Q1 device. Test conditions are $T_A = 25^\circ\text{C}$, $R_{PU} = 100\text{ k}\Omega$, $C_{Load} = 50\text{ pF}$, unless otherwise noted.

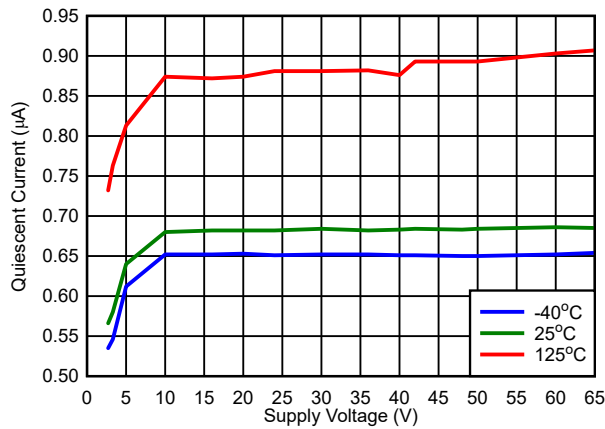

RESET = High, $V_{IT} = 2.7\text{ V}$

7-4. V_{DD} vs I_{DD} (RESET = High, $V_{IT} = 2.7\text{ V}$)

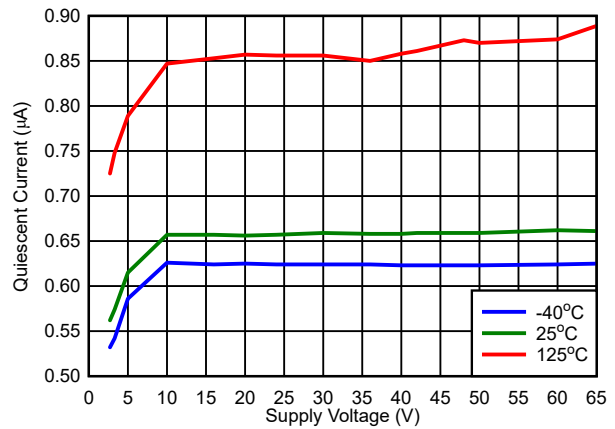

RESET = Low, $V_{IT} = 2.7\text{ V}$

7-5. V_{DD} vs I_{DD} (RESET = Low, $V_{IT} = 2.7\text{ V}$)

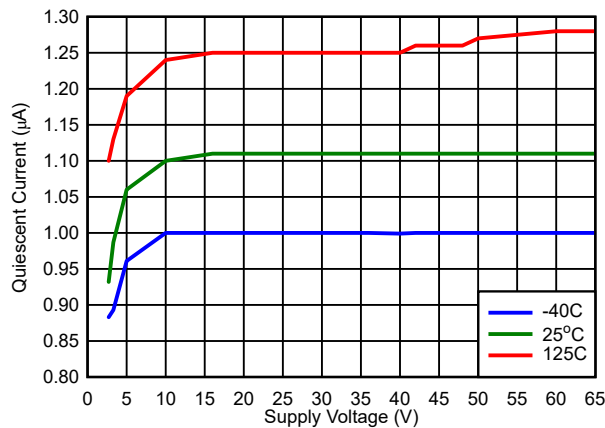

RESET = High, $V_{IT} = 0.8\text{ V}$

7-6. V_{DD} vs I_{DD} (RESET = High, $V_{IT} = 0.8\text{ V}$)

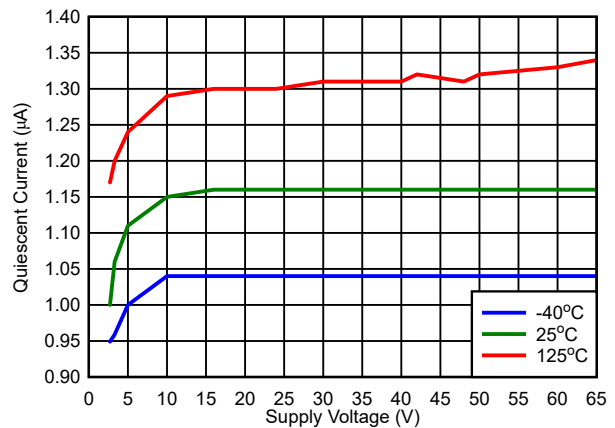

RESET = Low, $V_{IT} = 0.8\text{ V}$

7-7. V_{DD} vs I_{DD} (RESET = Low, $V_{IT} = 0.8\text{ V}$)

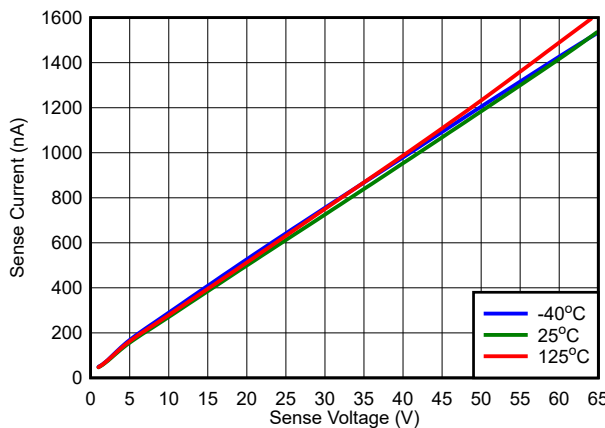

$V_{DD} = 2.7\text{ V}$

7-8. V_{SENSE} vs I_{SENSE}

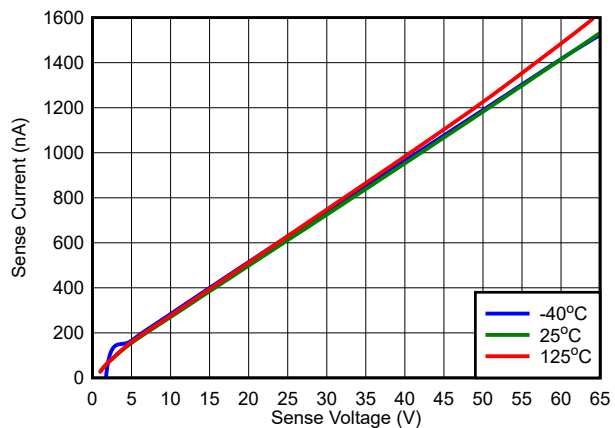

$V_{DD} = 65\text{ V}$

7-9. V_{SENSE} vs I_{SENSE}

7.8 Typical Characteristics (continued)

Typical characteristics show the typical performance of the TPS37-Q1 device. Test conditions are $T_A = 25^\circ\text{C}$, $R_{PU} = 100\text{ k}\Omega$, $C_{Load} = 50\text{ pF}$, unless otherwise noted.

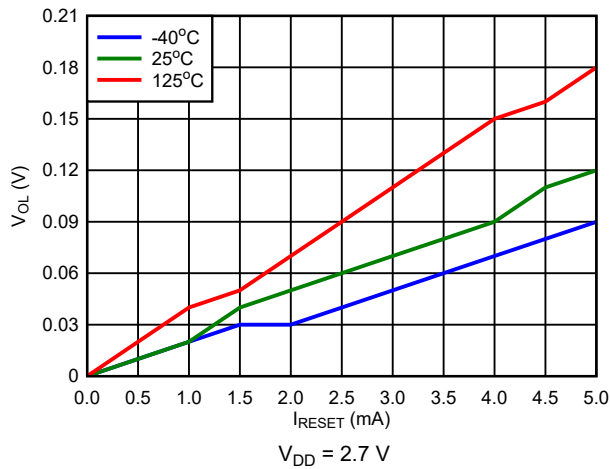

7-10. Open-Drain Active Low V_{OL} vs I_{RESET}

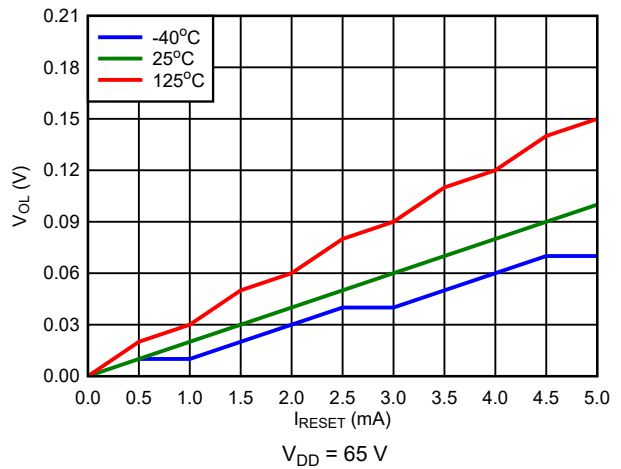

7-11. Open-Drain Active Low V_{OL} vs I_{RESET}

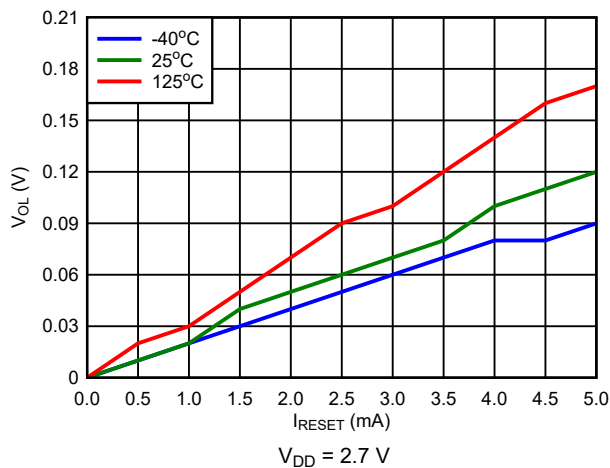

7-12. Open-Drain Active High V_{OL} vs I_{RESET}

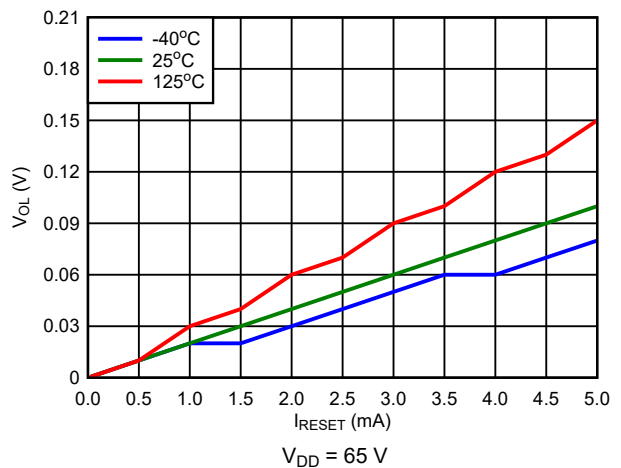

7-13. Open-Drain Active High V_{OL} vs I_{RESET}

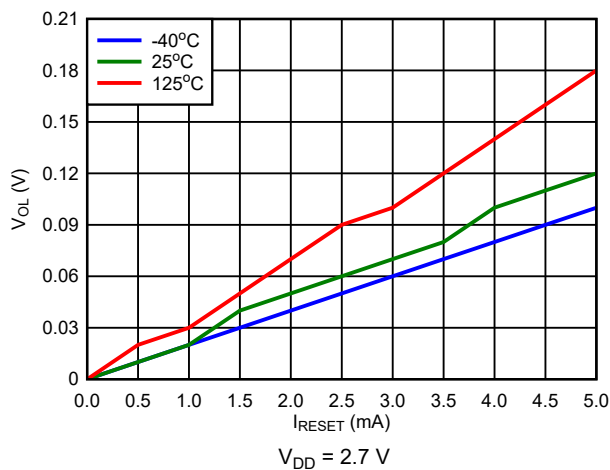

7-14. Push-Pull Active High V_{OL} vs I_{RESET}

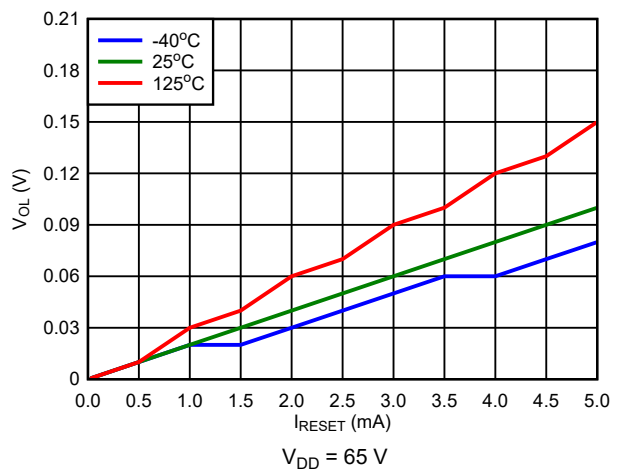

7-15. Push-Pull Active High V_{OL} vs I_{RESET}

7.8 Typical Characteristics (continued)

Typical characteristics show the typical performance of the TPS37-Q1 device. Test conditions are $T_A = 25^\circ\text{C}$, $R_{PU} = 100\text{ k}\Omega$, $C_{Load} = 50\text{ pF}$, unless otherwise noted.

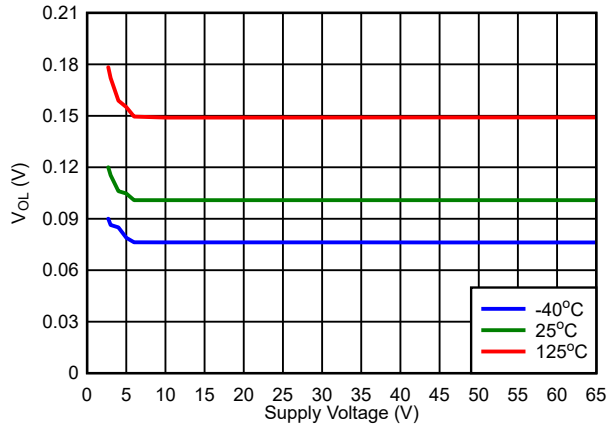

7-16. Open-Drain Active Low V_{OL} vs V_{DD}

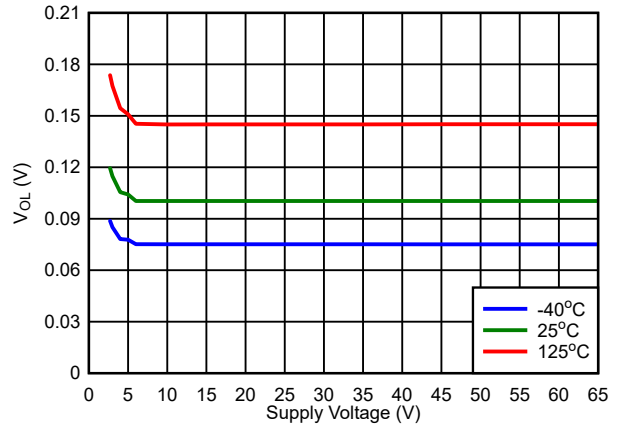

7-17. Open-Drain Active High V_{OL} vs V_{DD}

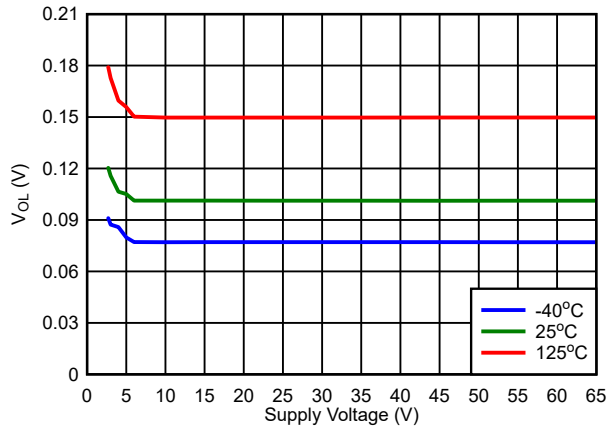

7-18. Push-Pull Active Low V_{OL} vs V_{DD}

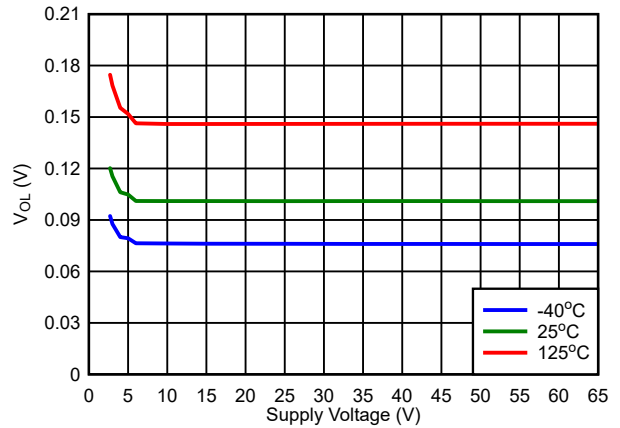

7-19. Push-Pull Active High V_{OL} vs V_{DD}

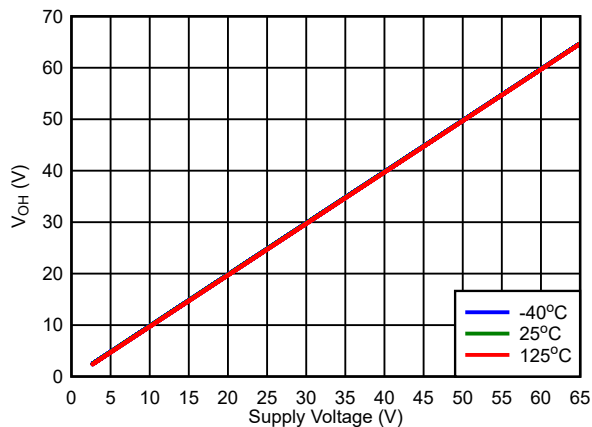

7-20. Push-Pull Active Low V_{OH} vs V_{DD}

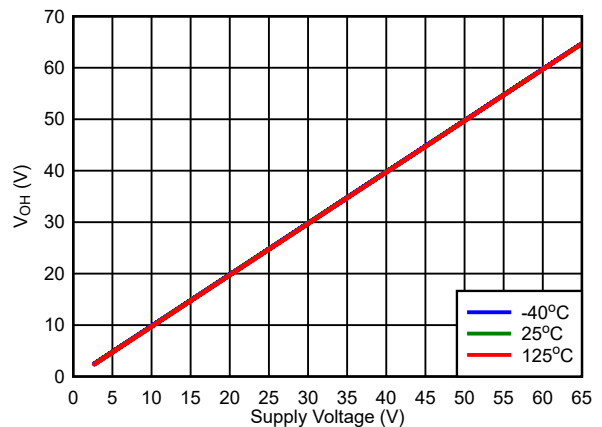

7-21. Push-Pull Active High V_{OH} vs V_{DD}

7.8 Typical Characteristics (continued)

Typical characteristics show the typical performance of the TPS37-Q1 device. Test conditions are $T_A = 25^\circ\text{C}$, $R_{PU} = 100\text{ k}\Omega$, $C_{Load} = 50\text{ pF}$, unless otherwise noted.

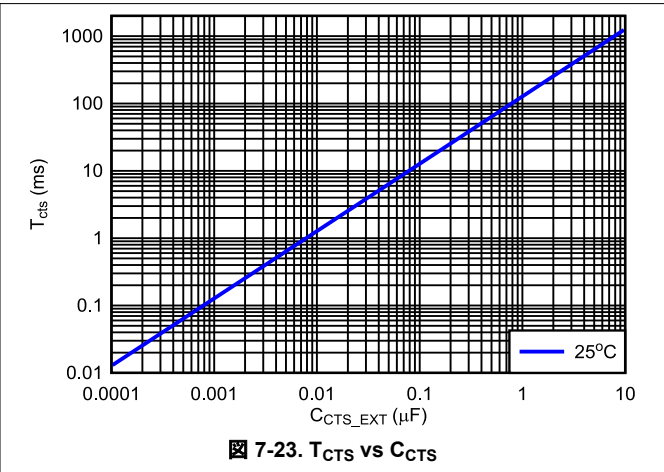
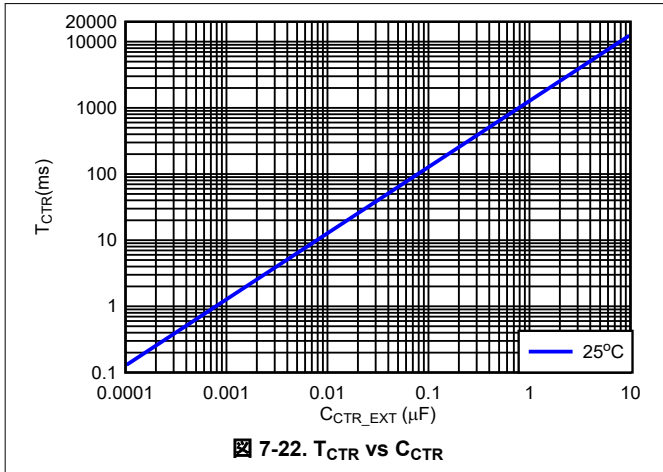

8 Detailed Description

8.1 Overview

The TPS37-Q1 is a family of high voltage and low quiescent current reset IC with fixed threshold voltage. Voltage divider is integrated to eliminate the need for external resistors and eliminate leakage current that comes with resistor dividers. However, it can also support external resistor if required by application, the lowest threshold 800 mV (bypass internal resistor ladder) is recommended for external resistors use case to take advantage of faster detection time and lower I_{SENSE} current.

VDD, SENSE and RESET pins can support 65 V continuous operation; both VDD and SENSE voltage levels can be independent of each other, meaning VDD pin can be connected at 2.7 V while SENSE pins are connected to a higher voltage. One thing of note, the TPS37-Q1 does not have clamps within the device so external circuits or devices must be added to limit the voltages to the absolute max limit.

Additional features include programmable sense time delay (CTS1, CTS2) and reset delay time and manual reset (CTR1 / \overline{MR} , CTR2 / \overline{MR}).

8.2 Functional Block Diagram

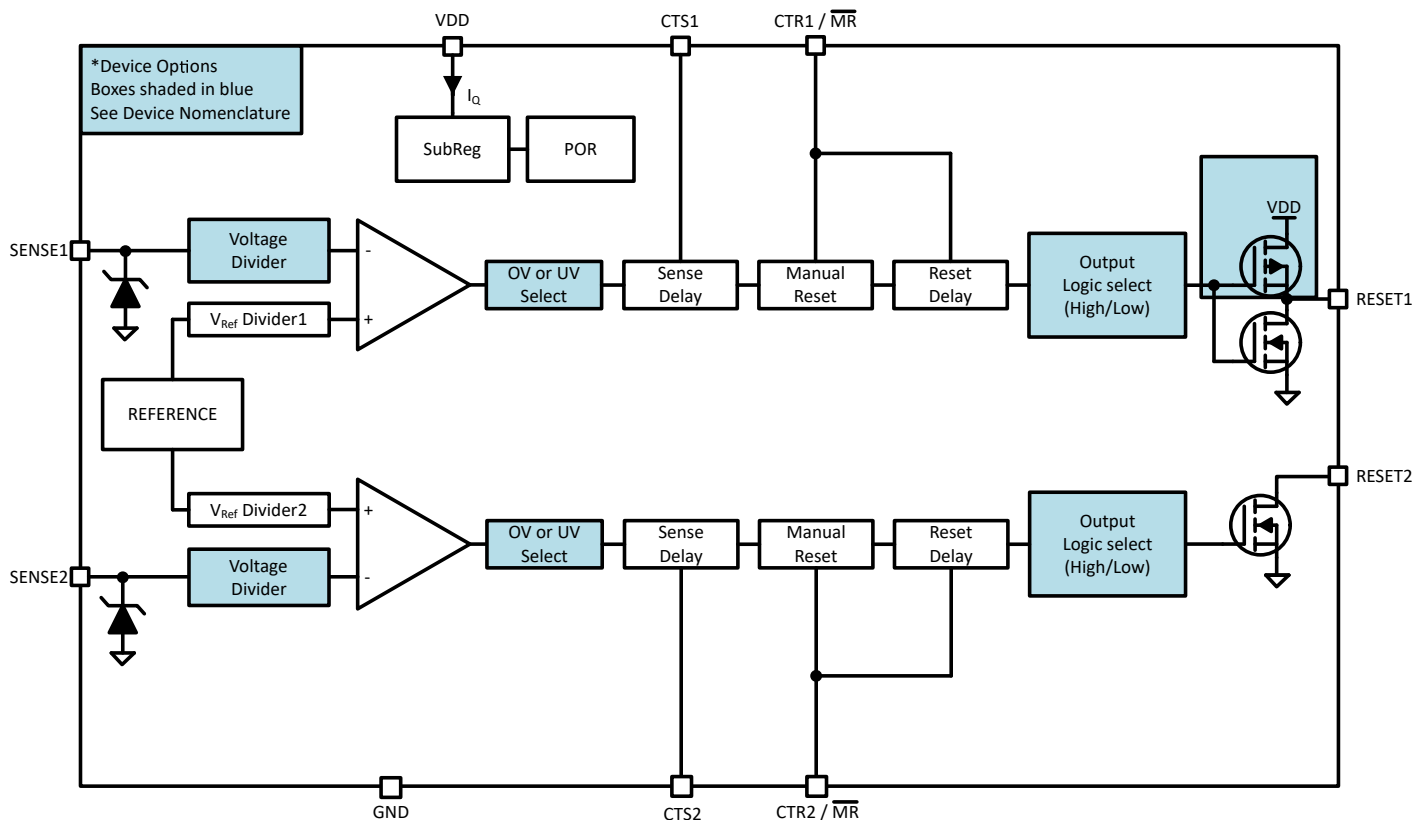

8-1. Functional Block Diagram ¹

¹ Refer to [セクション 5](#) for complete list of topologies and output logic combination

8.3 Feature Description

8.3.1 Input Voltage (VDD)

VDD operating voltage ranges from 2.7 V to 65 V. An input supply capacitor is not required for this device; however, if the input supply is noisy good analog practice is to place a 0.1 μF capacitor between the VDD and GND.

VDD needs to be at or above $V_{DD(MIN)}$ for at least the start-up time delay (t_{SD}) for the device to be fully functional.

VDD voltage is independent of V_{SENSE} and V_{RESET} , meaning that VDD can be higher or lower than the other pins.

8.3.1.1 Undervoltage Lockout ($V_{POR} < V_{DD} < UVLO$)

When the voltage on VDD is less than the UVLO voltage, but greater than the power-on reset voltage (V_{POR}), the output pins will be in reset, regardless of the voltage at SENSE pins.

8.3.1.2 Power-On Reset ($V_{DD} < V_{POR}$)

When the voltage on VDD is lower than the power on reset voltage (V_{POR}), the output signal is undefined and is not to be relied upon for proper device function.

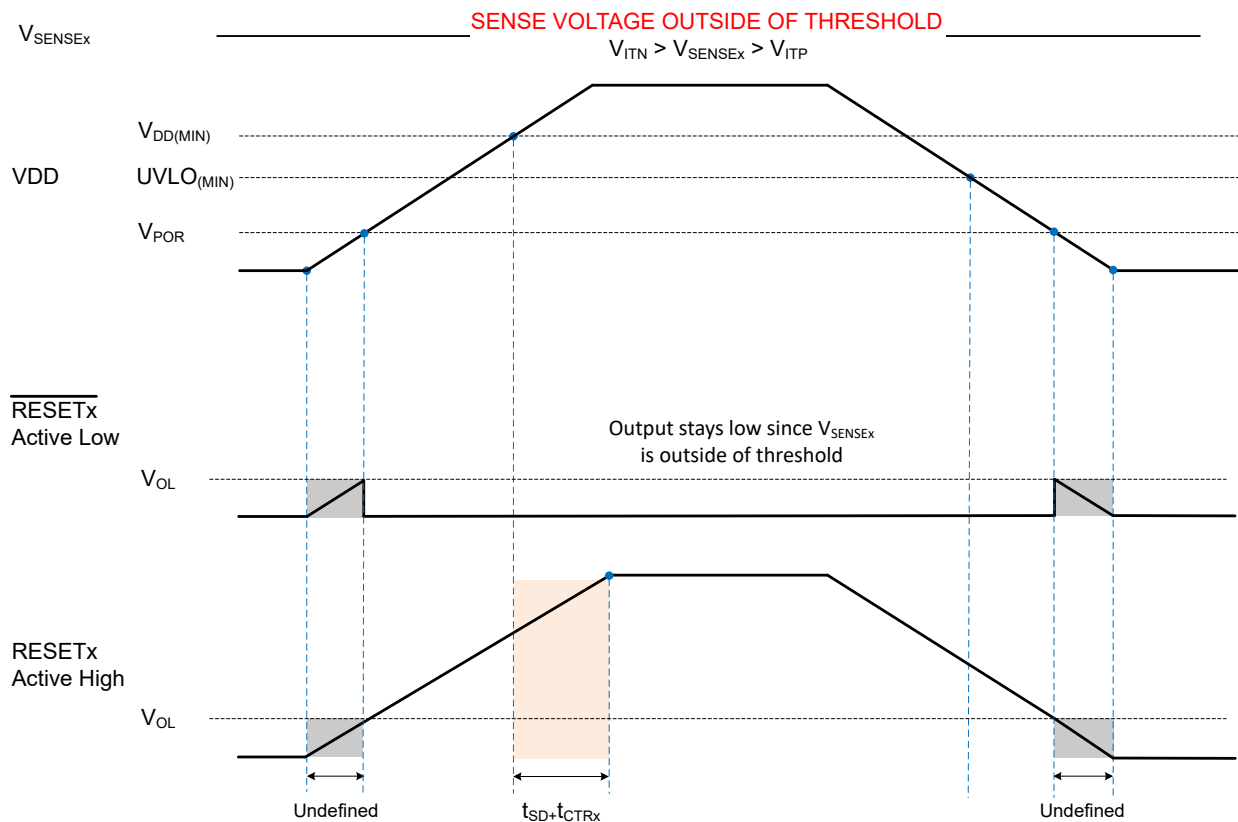

8-2. Power Cycle (SENSE Outside of Nominal voltage)²

² Figure assumes an external pull-up resistor is connected to the reset pin via VDD

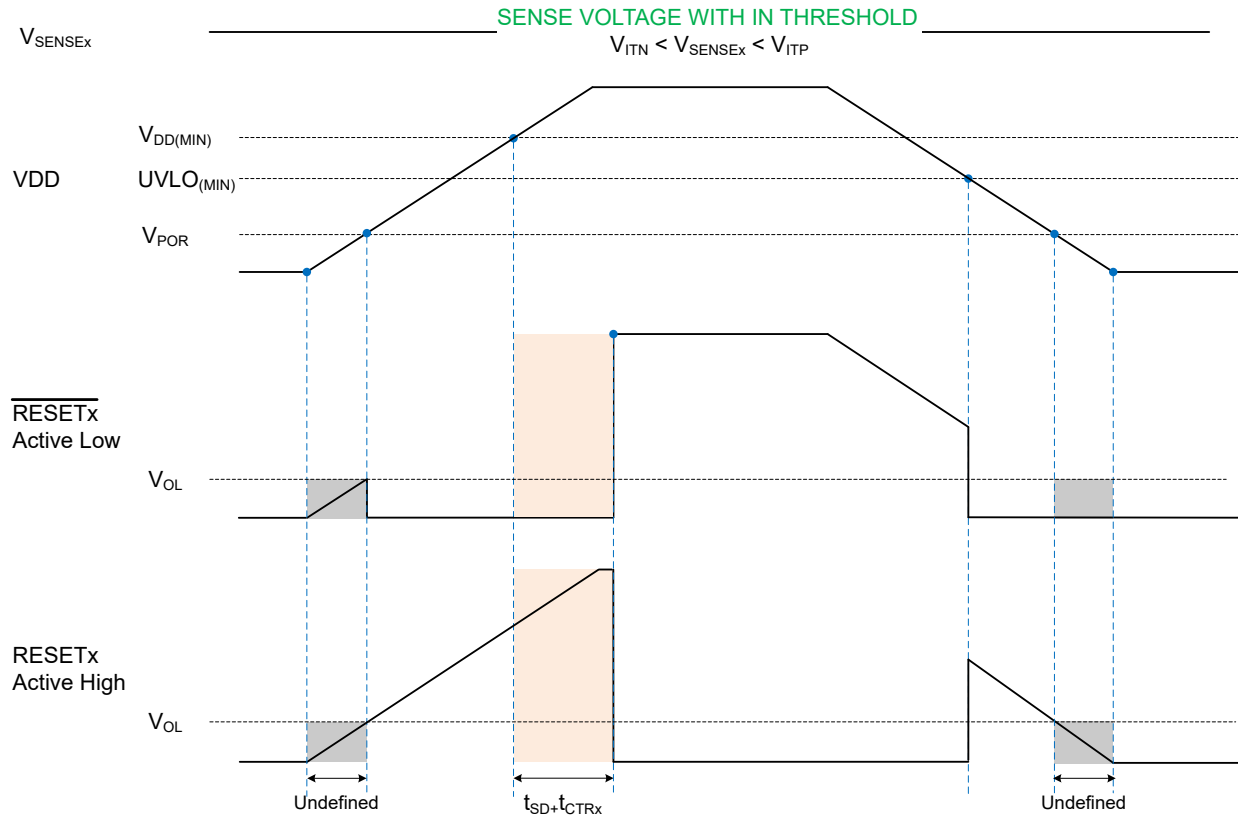

 **8-3. Power Cycle (SENSE Within Nominal voltage)** ³

³ Figure assumes an external pull-up resistor is connected to the reset pin via VDD

8.3.2 SENSE

The TPS37-Q1 high voltage family integrates two voltage comparators, a precision reference voltage and trimmed resistor divider. This configuration optimizes device accuracy because all resistor tolerances are accounted for in the accuracy and performance specifications. Device also has built-in hysteresis that provides noise immunity and ensures stable operation.

Channels are independent of each other, meaning that SENSE1 and SENSE2 and respective outputs can be connected to different voltage rails.

Although not required in most cases, for noisy applications good analog design practice is to place a 10 nF to 100 nF bypass capacitor at the SENSE_x inputs in order to reduce sensitivity to transient voltages on the monitored signal. SENSE1 and SENSE2 pins can be connected directly to VDD pin.

8.3.2.1 SENSE Hysteresis

Built-in hysteresis to avoid erroneous output reset release. The hysteresis is opposite to the threshold voltage; for overvoltage options the hysteresis is subtracted from the positive threshold (V_{ITP}), for undervoltage options hysteresis is added to the negative threshold (V_{ITN}).



表 8-1. Common Hysteresis Lookup Table

TARGET			DEVICE ACTUAL HYSTERESIS OPTION
DETECT THRESHOLD	TOPOLOGY	RELEASE VOLTAGE (V)	
18.0 V	Overvoltage	17.5 V	-3%
18.0 V	Overvoltage	16.0 V	-11%
17.0 V	Overvoltage	16.5 V	-3%
16.0 V	Overvoltage	15.0 V	-6%
15.0 V	Overvoltage	14.0 V	-7%
6.0 V	Undervoltage	6.5 V	0.5 V
5.5 V	Undervoltage	6 V	0.5 V
8 V	Undervoltage	9 V	1 V
5 V	Undervoltage	7.5 V	2.5 V

表 8-1 shows a sample of hysteresis and voltage options for the TPS37-Q1. For threshold voltages ranging from 2.7 V to 8 V, one option is to select a fixed hysteresis value ranging from 0.5 V to 2.5 V in increments of 0.5 V. Additionally, a second option can be selected where the hysteresis value is a percentage of the threshold voltage. The percentage of voltage hysteresis ranges from 2% to 13%.

Knowing the amount of hysteresis voltage, the release voltage for the undervoltage (UV) channel is $(V_{ITN(UV)} + V_{HYS})$ and for the overvoltage (OV) channel is $(V_{ITP(OV)} - V_{HYS})$. For a visual understanding of the UV and OV release voltage, see SENSEx Undervoltage (UV) Timing Diagram and SENSEx Overvoltage (OV) Timing Diagram. The accuracy of the release voltage, or stated in the [セクション 7.5](#) as *Hysteresis Accuracy* is $\pm 1.5\%$. Expanding what is shown in 表 8-1, below are a few voltage hysteresis examples that include the hysteresis accuracy:

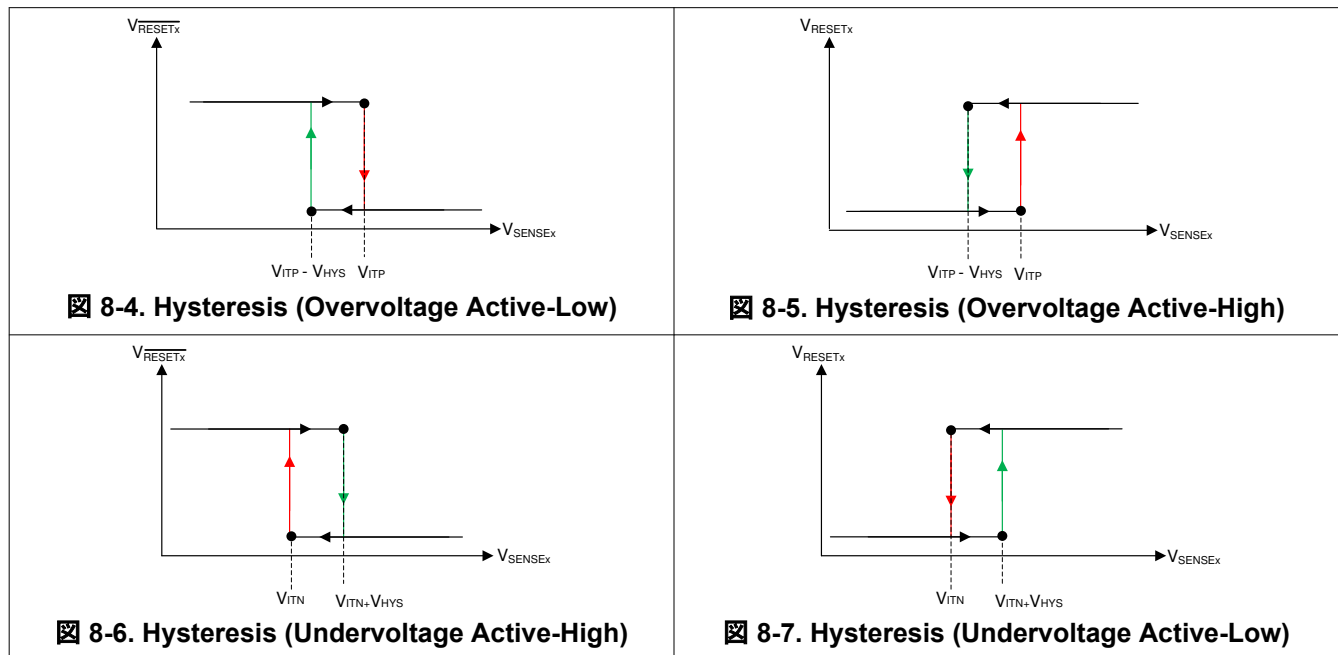
Undervoltage (UV) Channel

$$V_{ITN} = 0.8 \text{ V}$$

$$\text{Voltage Hysteresis } (V_{HYS}) = 5\% = 40 \text{ mV}$$

$$\text{Hysteresis Accuracy} = \pm 1.5\% = 39.4 \text{ mV or } 40.6 \text{ mV}$$

$$\text{Release Voltage} = V_{ITN} + V_{HYS} = 839.4 \text{ mV to } 840.6 \text{ mV}$$

Overvoltage (OV) Channel

$$V_{ITP} = 8 \text{ V}$$

$$\text{Voltage Hysteresis } (V_{HYS}) = 2 \text{ V}$$

$$\text{Hysteresis Accuracy} = \pm 1.5\% = 1.97 \text{ V or } 2.03 \text{ V}$$

$$\text{Release Voltage} = V_{ITP} - V_{HYS} = 5.97 \text{ V to } 6.03 \text{ V}$$

8.3.3 Output Logic Configurations

TPS37-Q1 has two channels with separate sense pins and reset pins that can be configured independently of each other. Channel 1 is available as Open-Drain and Push-Pull while channel 2 is only available as Open-Drain topology.

The available output logic configuration combinations are shown in [表 8-2](#).

表 8-2. TPS37-Q1 Output Logic

DESCRIPTION	NOMENCLATURE	VALUE	
		CHANNEL 1	CHANNEL 2
GPN	TPS37-Q1 (+ topology)		
Topology (OV and UV only) both channels are either OV or UV <ul style="list-style-type: none"> • UV = Undervoltage • OV = Overvoltage • PP = Push-Pull • OD = Open-Drain • L = Active low • H = Active high 	TPS37A-Q1	OV OD L	UV OD L
	TPS37B-Q1	OV PP H	UV OD L
	TPS37C-Q1	OV OD L	UV OD H
	TPS37D-Q1	OV PP H	UV OD H
	TPS37E-Q1	OV OD H	UV OD H
	TPS37F-Q1	OV OD H	UV OD L
	TPS37G-Q1	OV PP L	UV OD H
	TPS37H-Q1	OV PP L	UV OD L

8.3.3.1 Open-Drain

Open-drain output requires an external pull-up resistor to hold the voltage high to the required voltage logic. Connect the pull-up resistor to the proper voltage rail to enable the output to be connected to other devices at the correct interface voltage levels.

To select the right pull-up resistor consider system V_{OH} and the (I_{IKG}) current provided in the electrical characteristics, high resistors values will have a higher voltage drop affecting the output voltage high. The open-drain output can be connected as a wired-AND logic with other open-drain signals such as another TPS37-Q1 open-drain output pin.

8.3.3.2 Push-Pull

Push-Pull output does not require an external resistor since is the output is internally pulled-up to VDD during V_{OH} condition and output will be connected to GND during V_{OH} condition.

8.3.3.3 Active-High (RESET)

RESET (active-high), denoted with no bar above the pin label. RESET remains low (V_{OL} , deasserted) as long as sense voltage is in normal operation within the threshold boundaries and VDD voltage is above UVLO. To assert a reset sense pins needs to meet the condition below:

- For undervoltage variant the SENSE voltage need to cross the lower boundary (V_{ITN}).
- For overvoltage variant the SENSE voltage needs to cross the upper boundary (V_{ITP}).

8.3.3.4 Active-Low (RESET)

$\overline{\text{RESET}}$ (active low) denoted with a bar above the pin label. $\overline{\text{RESET}}$ remains high voltage (V_{OH} , deasserted) (open-drain variant V_{OH} is measured against the pullup voltage) as long as sense voltage is in normal operation within the threshold boundaries and VDD voltage is above UVLO. To assert a reset sense pins needs to meet the condition below:

- For undervoltage variant the SENSE voltage need to cross the lower boundary (V_{ITN}).
- For overvoltage variant the SENSE voltage needs to cross the upper boundary (V_{ITP}).

8.3.4 User-Programmable Reset Time Delay

TPS37-Q1 has adjustable reset release time delay with external capacitors. Channel timing are independent of each other.

- A capacitor in CTR1 / \overline{MR} program the reset time delay of Output 1.
- A capacitor in CTR2 / \overline{MR} program the reset time delay of Output 2.
- No capacitor on these pins gives the fastest reset delay time indicated in the [セクション 7.6](#).

8.3.4.1 Reset Time Delay Configuration

The time delay (t_{CTR}) can be programmed by connecting a capacitor between CTR1 pin and GND, CTR2 for channel 2. In this section CTRx represent either channel 1 or channel 2.

The relationship between external capacitor $C_{CTR_EXT (typ)}$ and the time delay $t_{CTR (typ)}$ is given by [式 1](#).

$$t_{CTR (typ)} = -\ln(0.28) \times R_{CTR (typ)} \times C_{CTR_EXT (typ)} + t_{CTR (no\ cap)} \quad (1)$$

$R_{CTR (typ)}$ = is in kilo ohms (kOhms)

$C_{CTR_EXT (typ)}$ = is given in microfarads (μ F)

$t_{CTR (typ)}$ = is the reset time delay (ms)

The reset delay varies according to three variables: the external capacitor (C_{CTR_EXT}), CTR pin internal resistance (R_{CTR}) provided in [セクション 7.5](#), and a constant. The minimum and maximum variance due to the constant is show in [式 2](#) and [式 3](#):

$$t_{CTR (min)} = -\ln(0.31) \times R_{CTR (min)} \times C_{CTR_EXT (min)} + t_{CTR (no\ cap (min))} \quad (2)$$

$$t_{CTR (max)} = -\ln(0.25) \times R_{CTR (max)} \times C_{CTR_EXT (max)} + t_{CTR (no\ cap (max))} \quad (3)$$

The recommended maximum reset delay capacitor for the TPS37-Q1 is limited to 10 μ F as this ensures enough time for the capacitor to fully discharge when a voltage fault occurs. Also, having a too large of a capacitor value can cause very slow charge up (rise times) and system noise can cause the the internal circuit to trip earlier or later near the threshold. This leads to variation in time delay where it can make the delay accuracy worse in the presence of system noise.

When a voltage fault occurs, the previously charged up capacitor discharges and if the monitored voltage returns from the fault condition before the delay capacitor discharges completely, the delay will be shorter than expected. The capacitor will begin charging from a voltage above zero and resulting in shorter than expected time delay. A larger delay capacitor can be used so long as the capacitor has enough time to fully discharge during the duration of the voltage fault. To ensure the capacitor is fully discharged, the time period or duration of the voltage fault needs to be greater than 5% of the programmed reset time delay.

8.3.5 User-Programmable Sense Delay

TPS37-Q1 has adjustable sense release time delay with external capacitors. Channel timing are independent of each other. Sense delay is used as a de-glitcher or ignoring known transients.

- A capacitor in CTS1 program the excursion detection on SENSE1.
- A capacitor in CTS2 program the excursion detection on SENSE2.
- No capacitor on these pins gives the fastest detection time indicated in the [セクション 7.6](#).

8.3.5.1 Sense Time Delay Configuration

The time delay (t_{CTS}) can be programmed by connecting a capacitor between CTS1 pin and GND, CTS2 for channel 2. In this section CTSx represent either channel 1 or channel 2.R

The relationship between external capacitor $C_{CTSx_EXT (typ)}$ and the time delay $t_{CTSx (typ)}$ is given by [式 4](#).

$$t_{CTSx (typ)} = -\ln (0.28) \times R_{CTSx (typ)} \times C_{CTSx_EXT (typ)} + t_{CTSx (no cap)} \quad (4)$$

R_{CTSx} = is in kilo ohms (kOhms)

C_{CTSx_EXT} = is given in microfarads (μF)

t_{CTSx} = is the sense time delay (ms)

The sense delay varies according to three variables: the external capacitor (C_{CTSx_EXT}), CTS pin internal resistance (R_{CTSx}) provided in [セクション 7.5](#), and a constant. The minimum and maximum variance due to the constant is show in [式 5](#) and [式 6](#):

$$t_{CTSx (min)} = -\ln (0.31) \times R_{CTSx (min)} \times C_{CTSx_EXT (min)} + t_{CTSx (no cap (min))} \quad (5)$$

$$t_{CTSx (max)} = -\ln (0.25) \times R_{CTSx (max)} \times C_{CTSx_EXT (max)} + t_{CTSx (no cap (max))} \quad (6)$$

The recommended maximum sense delay capacitor for the TPS37-Q1 is limited to 10 μF as this ensures enough time for the capacitor to fully discharge when a voltage fault occurs. Also, having a too large of a capacitor value can cause very slow charge up (rise times) and system noise can cause the the internal circuit to trip earlier or later near the threshold. This leads to variation in time delay where it can make the delay accuracy worse in the presence of system noise.

When a voltage fault occurs, the previously charged up capacitor discharges and if the monitored voltage returns from the fault condition before the delay capacitor discharges completely, the delay will be shorter than expected. The capacitor will begin charging from a voltage above zero and resulting in shorter than expected time delay. A larger delay capacitor can be used so long as the capacitor has enough time between fault events to fully discharge during the duration of the voltage fault. To ensure the capacitor is fully discharged, the time period or time duration between fault events needs to be greater than 10% of the programmed sense time delay.

8.3.6 Manual RESET (CTR1 / \overline{MR}) and (CTR2 / \overline{MR}) Input

The manual reset input allows a processor or other logic circuits to initiate a reset. In this section \overline{MR} is a generic reference to (CTR1 / \overline{MR}) and (CTR2 / \overline{MR}). A logic low on \overline{MR} causes $\overline{RESET1}$ to assert on reset output. After \overline{MR} is left floating, $\overline{RESET1}$ will release the reset if the voltage at SENSE1 pin is at nominal voltage. \overline{MR} should not be driven high, this pin should be left floating or connected to a capacitor to GND, this pin can be left unconnected if is not used.

If the logic driving the \overline{MR} cannot tri-state (floating and GND) then a logic-level FET should be used as illustrated in [8-8](#).

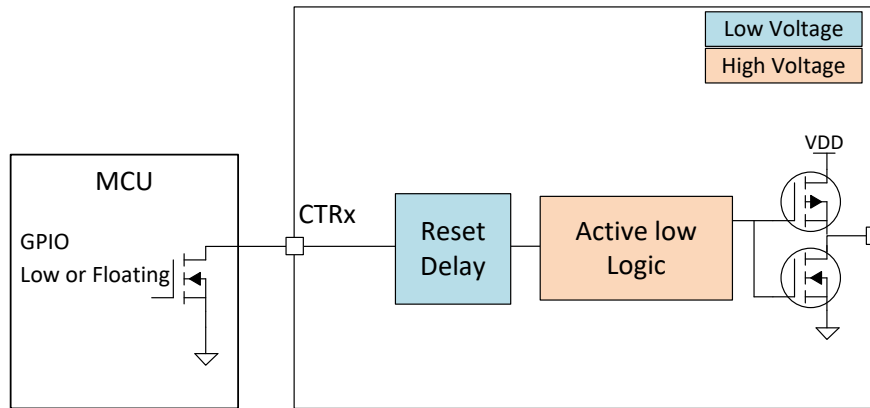

8-8. Manual Reset Implementation

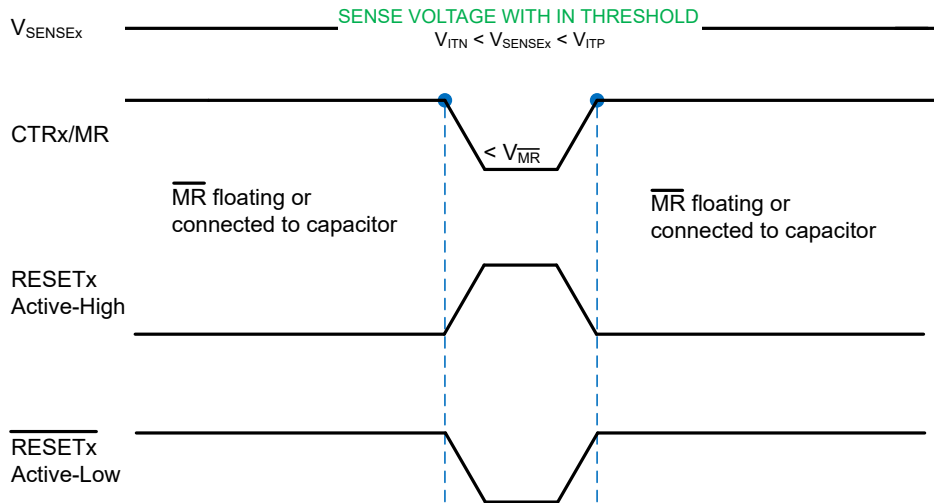

8-9. Manual Reset Timing Diagram

表 8-3. \overline{MR} Functional Table

MR	SENSE ON NOMINAL VOLTAGE	RESET STATUS
Low	Yes	Reset asserted
Floating	Yes	Fast reset release when SENSE voltage goes back to nominal voltage
Capacitor	Yes	Programmable reset time delay
High	Yes	NOT Recommended

9 Device Functional Modes

表 9-1. Undervoltage Detect Functional Mode Truth Table

DESCRIPTION	SENSE		CTR ⁽¹⁾ / MR PIN	VDD PIN	OUTPUT ⁽²⁾ (RESET PIN)
	PREVIOUS CONDITION	CURRENT CONDITION			
Normal Operation	$SENSE > V_{ITN(UV)}$	$SENSE > V_{ITN(UV)}$	Open or capacitor connected	$V_{DD} > V_{DD(MIN)}$	High
Undervoltage Detection	$SENSE > V_{ITN(UV)}$	$SENSE < V_{ITN(UV)}$	Open or capacitor connected	$V_{DD} > V_{DD(MIN)}$	Low
Undervoltage Detection	$SENSE < V_{ITN(UV)}$	$SENSE > V_{ITN(UV)}$	Open or capacitor connected	$V_{DD} > V_{DD(MIN)}$	Low
Normal Operation	$SENSE < V_{ITN(UV)}$	$SENSE > V_{ITN(UV)} + HYS$	Open or capacitor connected	$V_{DD} > V_{DD(MIN)}$	High
Manual Reset	$SENSE > V_{ITN(UV)}$	$SENSE > V_{ITN(UV)}$	Low	$V_{DD} > V_{DD(MIN)}$	Low
UVLO Engaged	$SENSE > V_{ITN(UV)}$	$SENSE > V_{ITN(UV)}$	Open or capacitor connected	$V_{POR} < V_{DD} < V_{DD(MIN)}$	Low
Below V_{POR} , Undefined Output	$SENSE > V_{ITN(UV)}$	$SENSE > V_{ITN(UV)}$	Open or capacitor connected	$V_{DD} < V_{POR}$	Undefined

(1) Reset time delay is ignored in the truth table.

(2) Open-drain active low output requires an external pull-up resistor to a pull-up voltage.

表 9-2. Overvoltage Detect Functional Mode Truth Table

DESCRIPTION	SENSE		CTR ⁽¹⁾ / MR PIN	VDD PIN	OUTPUT ⁽²⁾ (RESET PIN)
	PREVIOUS CONDITION	CURRENT CONDITION			
Normal Operation	$SENSE < V_{ITN(OV)}$	$SENSE < V_{ITN(OV)}$	Open or capacitor connected	$V_{DD} > V_{DD(MIN)}$	High
Overvoltage Detection	$SENSE < V_{ITN(OV)}$	$SENSE > V_{ITN(OV)}$	Open or capacitor connected	$V_{DD} > V_{DD(MIN)}$	Low
Overvoltage Detection	$SENSE > V_{ITN(OV)}$	$SENSE < V_{ITN(OV)}$	Open or capacitor connected	$V_{DD} > V_{DD(MIN)}$	Low
Normal Operation	$SENSE > V_{ITN(OV)}$	$SENSE < V_{ITN(OV)} - HYS$	Open or capacitor connected	$V_{DD} > V_{DD(MIN)}$	High
Manual Reset	$SENSE < V_{ITN(OV)}$	$SENSE < V_{ITN(OV)}$	Low	$V_{DD} > V_{DD(MIN)}$	Low
UVLO Engaged	$SENSE < V_{ITN(OV)}$	$SENSE < V_{ITN(OV)}$	Open or capacitor connected	$V_{POR} < V_{DD} < UVLO$	Low
Below V_{POR} , Undefined Output	$SENSE < V_{ITN(OV)}$	$SENSE < V_{ITN(OV)}$	Open or capacitor connected	$V_{DD} < V_{POR}$	Undefined

(1) Reset time delay is ignored in the truth table.

(2) Open-drain active low output requires an external pull-up resistor to a pull-up voltage.

10 Application and Implementation

注

以下のアプリケーション情報は、TI の製品仕様に含まれるものではなく、TI ではその正確性または完全性を保証いたしません。個々の目的に対する製品の適合性については、お客様の責任で判断していただくこととなります。お客様は自身の設計実装を検証しテストすることで、システムの機能を確認する必要があります。

10.1 Adjustable Voltage Thresholds

式 7 illustrates an example of how to adjust the voltage threshold with external resistor dividers. The resistors can be calculated depending on the desired voltage threshold and device part number. TI recommends using the 0.8 V voltage threshold device when using an adjustable voltage variant. This variant bypasses the internal resistor ladder.

For example, consider a 12 V rail being monitored V_{MON} for undervoltage (UV) using channel 2 of the TPS37A010122DSKRQ1 variant. Using 式 7 and shown in 図 10-1, R_1 is the top resistor of the resistor divider that is between V_{MON} and V_{SENSE2} , R_2 is the bottom resistor that is between V_{SENSE2} and GND, V_{MON} is the voltage rail that is being monitored and V_{SENSE2} is the input threshold voltage. The monitored UV threshold, denoted as V_{MON-} , where the device will assert a reset signal occurs when $V_{SENSE2} = V_{IT-(UV)}$ or, for this example, $V_{MON-} = 10.8V$ which is 90% from 12 V. Using 式 7 and assuming $R_2 = 10k\Omega$, R_1 can be calculated shown in 式 8 where I_{R1} is represented in 式 9:

$$V_{SENSE2} = V_{MON-} \times (R_2 \div (R_1 + R_2)) \quad (7)$$

$$R_1 = (V_{MON-} - V_{SENSE2}) \div I_{R1} \quad (8)$$

$$I_{R1} = I_{R2} = V_{SENSE2} \div R_2 \quad (9)$$

Substituting 式 9 into 式 8 and solving for R_1 in 式 7, $R_1 = 125k\Omega$. The TPS37A010122DSKRQ1 is typically meant to monitor a 0.8 V rail with $\pm 2\%$ voltage threshold hysteresis. For the reset signal to become deasserted, V_{MON} would need to go above $V_{IT-} + V_{HYS}$. For this example, $V_{MON} = 11.016 V$ when the reset signal becomes deasserted.

There are inaccuracies that must be taken into consideration while adjusting voltage thresholds. Aside from the tolerance of the resistor divider, there is an internal resistance of the SENSE pin that may affect the accuracy of the resistor divider. Although expected to be very high impedance, users are recommended to calculate the values for the design specifications. The internal SENSE resistance R_{SENSE} can be calculated by the SENSE voltage V_{SENSE} divided by the SENSE current I_{SENSE} as shown in 式 11. V_{SENSE} can be calculated using 式 7 depending on the resistor divider and monitored voltage. I_{SENSE} can be calculated using 式 10.

$$I_{SENSE} = [(V_{MON} - V_{SENSE}) \div R_1] - (V_{SENSE} \div R_2) \quad (10)$$

$$R_{SENSE} = V_{SENSE} \div I_{SENSE} \quad (11)$$

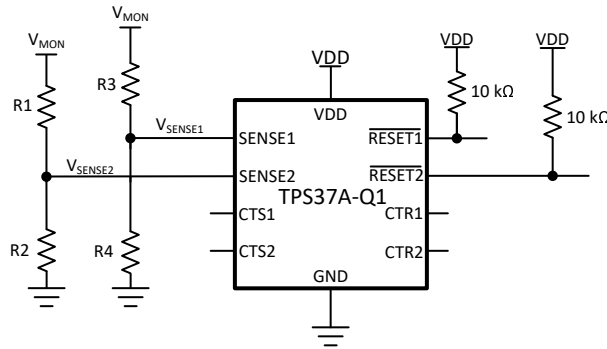

10-1. Adjustable Voltage Threshold with External Resistor Dividers

10.2 Application Information

The following sections describe in detail how to properly use this device, depending on the requirements of the final application.

10.3 Typical Application

10.3.1 Design 1: Automotive Off-Battery Monitoring

The initial power stage in automotive applications starts with the 12 V battery. Variation of the battery voltage is common between 9 V and 16 V. Furthermore, if cold-cranking and load dump conditions are considered, voltage transients can occur as low as 3 V and as high as 42 V. In this design example, we are highlighting the ability for low power, direct off-battery voltage supervision. 10-2 illustrates an example of how the TPS37-Q1 is monitoring the battery voltage while being powered by it, as well. For more information, read this [application report](#) on how to achieve low I_Q voltage supervision in automotive, wide- V_{IN} applications.

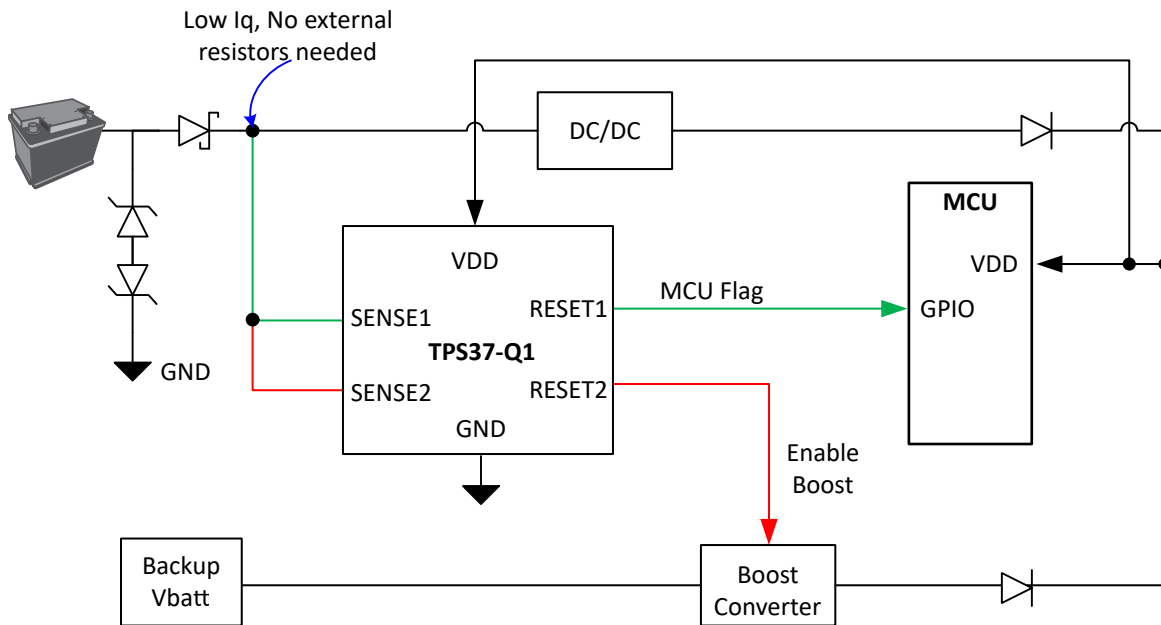

10-2. Fast Start Window Supervisor with Direct Off-Battery Monitoring

10.3.1.1 Design Requirements

This design requires voltage supervision on a 12 V power supply voltage rail with possibility of the 12 V rail rising up as high as 42 V. The undervoltage fault occurs when the power supply voltage drops below 7.7 V.

PARAMETER	DESIGN REQUIREMENT	DESIGN RESULT
Power Rail Voltage Supervision	Monitor 12-V power supply for undervoltage condition, trigger a undervoltage fault at 7.7 V.	TPS37-Q1 provides voltage monitoring with 1.5% max accuracy with adjustable/non-adjustable variations.
Maximum Input Power	Operate with power supply input up to 42 V.	The TPS37-Q1 can support a VDD of up to 65 V.
Output logic voltage	Open-Drain Output Topology	An open-drain output is recommended to provide the correct reset signal, but a push-pull can also be used.
Maximum system current consumption	2 μ A max when power supply is at 12 V typical	TPS37-Q1 allows for I_Q to remain low with support of up to 65 V. This allows for no external resistor divider to be required.
Voltage Monitor Accuracy	Maximum voltage monitor accuracy of 1.5%.	The TPS37-Q1 has 1.5% maximum voltage monitor accuracy.
Delay when returning from fault condition	RESET delay of at least 12.8 ms when returning from a undervoltage fault.	$C_{CTR} = 10$ nF sets 12.8 ms delay

10.3.1.2 Detailed Design Procedure

The primary advantage of this application is being able to directly monitor a voltage on an automotive battery without needing external resistor dividers on the SENSEx inputs. This keeps the overall I_Q of the design low while still achieving the desired rail monitoring.

As shown in [Figure 10-2](#), rail monitoring is done by connecting SENSE1 and SENSE2 inputs directly to the battery rail after the TVS protection diodes. The TPS37-Q1 that is being used in this example is a fixed voltage variant where SENSE1 and SENSE 2 threshold voltages have been set internally by the factory. Word of caution, the TVS protection diodes must be chosen such that the transient voltages on the monitored rails do not exceed the absolute max limit listed in [Section 7.1](#).

To use this configuration, the specific voltage threshold variation of the device must be chosen according to the application. In this configuration, the '77' variation must be chosen for 7.7 V as shown in [Table 11-1](#).

The device being able to handle 65 V on VDD means the monitored voltage rail can go as high as 42 V for the application transients and not violate the recommended maximum for the supervisor as it usually would. This is useful when monitoring a voltage rail that has a wide range that may go much higher than the nominal rail voltage such as in this case. Good design practice recommends using a 0.1 μ F capacitor on the VDD pin and this capacitance may need to increase if using an adjustable version with a resistor divider.

10.3.1.3 Application Curves

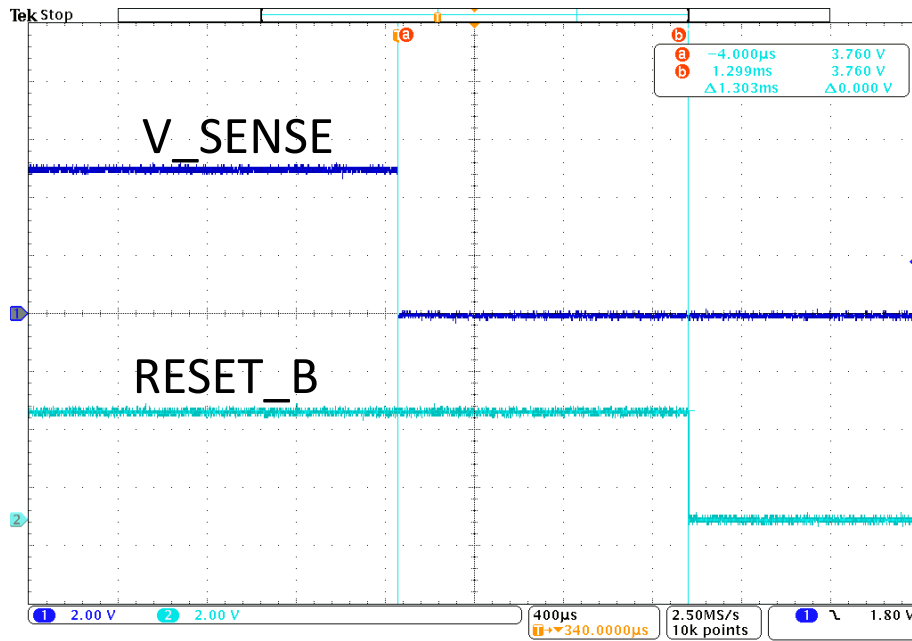

10-3. Undervoltage Reset Waveform

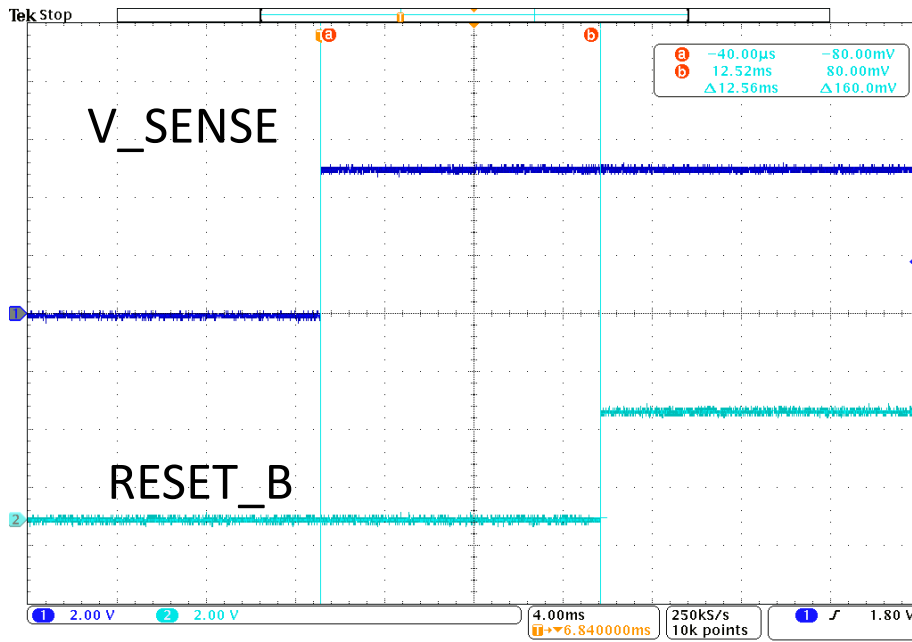

10-4. Undervoltage Recovery Waveform

10.4 Power Supply Recommendations

These devices are designed to operate from an input supply with a voltage range between 1.4 V (V_{POR}) to 65 V (max operation). Good analog design practice recommends placing a minimum 0.1 μ F ceramic capacitor as near as possible to the VDD pin.

10.4.1 Power Dissipation and Device Operation

The permissible power dissipation for any package is a measure of the capability of the device to pass heat from the power source, the junctions of the IC, to the ultimate heat sink, the ambient environment. Thus, the power dissipation is dependent on the ambient temperature and the thermal resistance across the various interfaces between the die junction and ambient air.

The maximum continuous allowable power dissipation for the device in a given package can be calculated using 式 12:

$$P_{D-MAX} = ((T_{J-MAX} - T_A) / R_{\theta JA}) \quad (12)$$

The actual power being dissipated in the device can be represented by 式 13:

$$P_D = V_{DD} \times I_{DD} + P_{RESET} \quad (13)$$

P_{RESET} is calculated by 式 14 or 式 15

$$P_{RESET (PUSH/PULL)} = V_{DD} - V_{RESET} \times I_{RESET} \quad (14)$$

$$P_{RESET (OPEN-DRAIN)} = V_{RESET} \times I_{RESET} \quad (15)$$

式 12 and 式 13 establish the relationship between the maximum power dissipation allowed due to thermal consideration, the voltage drop across the device, and the continuous current capability of the device. These two equations should be used to determine the optimum operating conditions for the device in the application.

In applications where lower power dissipation (P_D) and/or excellent package thermal resistance ($R_{\theta JA}$) is present, the maximum ambient temperature (T_{A-MAX}) may be increased.

In applications where high power dissipation and/or poor package thermal resistance is present, the maximum ambient temperature (T_{A-MAX}) may have to be de-rated. T_{A-MAX} is dependent on the maximum operating junction temperature ($T_{J-MAX-OP} = 125^\circ\text{C}$), the maximum allowable power dissipation in the device package in the application (P_{D-MAX}), and the junction-to ambient thermal resistance of the part/package in the application ($R_{\theta JA}$), as given by 式 16:

$$T_{A-MAX} = (T_{J-MAX-OP} - (R_{\theta JA} \times P_{D-MAX})) \quad (16)$$

10.5 Layout

10.5.1 Layout Guidelines

- Make sure that the connection to the VDD pin is low impedance. Good analog design practice is to place a greater than 0.1 μ F ceramic capacitor as near as possible to the VDD pin.
- To further improve the noise immunity on the SENSEx pins, placing a 10 nF to 100 nF capacitor between the SENSEx pins and GND can reduce the sensitivity to transient voltages on the monitored signal.
- If a capacitor is used on CTS1, CTS2, CTR1, or CTR2, place these components as close as possible to the respective pins. If the capacitor adjustable pins are left unconnected, make sure to minimize the amount of parasitic capacitance on the pins to less than 5 pF.
- For open-drain variants, place the pull-up resistors on $\overline{RESET1}$ and $\overline{RESET2}$ pins as close to the pins as possible.
- When laying out metal traces, separate high voltage traces from low voltage traces as much as possible. If high and low voltage traces need to run close by, spacing between traces should be greater than 20 mils (0.5 mm).

TPS37-Q1

JAJSKP2E – AUGUST 2020 – REVISED AUGUST 2023

- Do not have high voltage metal pads or traces closer than 20 mils (0.5 mm) to the low voltage metal pads or traces.

10.5.2 Layout Example

The DSK layout example in [10-5](#) shows how the TPS37-Q1 is laid out on a printed circuit board (PCB) with user-defined delays.

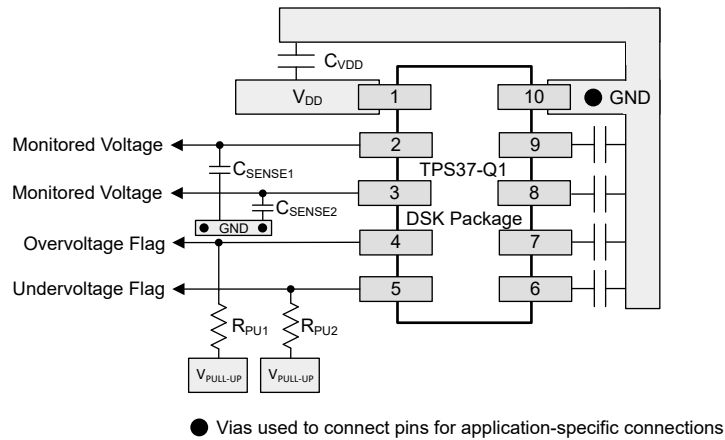

10-5. TPS37-Q1 DSK Package Recommended Layout

The DYY layout example in [10-6](#) shows how the TPS37-Q1 is laid out on a printed circuit board (PCB) with user-defined delays.

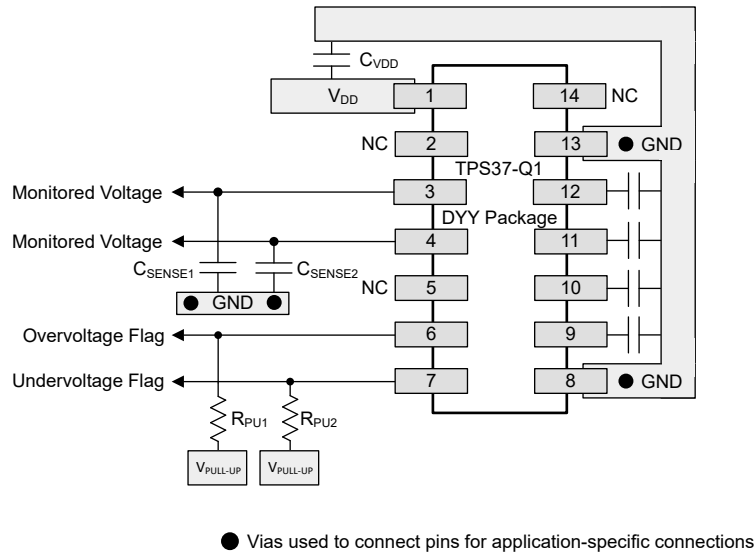

10-6. TPS37-Q1 DYY Package Recommended Layout

10.5.3 Creepage Distance

Per IEC 60664 Creepage is the shortest distance between two conductive parts or as shown in [10-7](#) the distance between high voltage conductive parts and grounded parts, the floating conductive part is ignored and subtracted from the total distance.

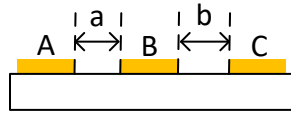

10-7. Creepage Distance

[10-7](#) details:

- A = Left pins (high voltage)
- B = Central pad (not internally connected, can be left floating or connected to GND)
- C = Right pins (low voltage)
- Creepage distance = a + b

11 Device and Documentation Support

11.1 Device Nomenclature

セクション 5 shows how to decode the function of the device based on its part number

表 11-1 shows TPS37-Q1 possible voltage options per channel. Contact TI sales representatives or on TI's E2E forum for details and availability of other options; minimum order quantities apply.

表 11-1. Voltage Options

100 mV STEPS				400 mV STEPS		500 mV STEPS		1 V STEPS	
NOMEN- CLATURE	VOLTAGE OPTIONS	NOMEN- CLATURE	VOLTAGE OPTIONS	NOMEN- CLATURE	VOLTAGE OPTIONS	NOMEN- CLATURE	VOLTAGE OPTIONS	NOMEN- CLATURE	VOLTAGE OPTIONS
01	800 mV (divider bypass)	70	7.0 V	A0	10.4 V	D0	20.5 V	F0	31.0 V
27	2.7 V	71	7.1 V	A1	10.8 V	D1	21.0 V	F1	32.0 V
28	2.8 V	72	7.2 V	A2	11.2 V	D2	21.5 V	F2	33.0 V
29	2.9 V	73	7.3 V	A3	11.6 V	D3	22.0 V	F3	34.0 V
30	3.0 V	74	7.4 V	A4	12.0 V	D4	22.5 V	F4	35.0 V
31	3.1 V	75	7.5 V	A5	12.4 V	D5	23.0 V	F5	36.0 V
32	3.2 V	76	7.6 V	A6	12.8 V	D6	23.5 V		
33	3.3 V	77	7.7 V	A7	13.2 V	D7	24.0 V		
34	3.4 V	78	7.8 V	A8	13.6 V	D8	24.5 V		
35	3.5 V	79	7.9 V	A9	14.0 V	D9	25.0 V		
36	3.6 V	80	8.0 V	B0	14.4 V	E0	25.5 V		
37	3.7 V	81	8.1 V	B1	14.8 V	E1	26.0 V		
38	3.8 V	82	8.2 V	B2	15.2 V	E2	26.5 V		
39	3.9 V	83	8.3 V	B3	15.6 V	E3	27.0 V		
40	4.0 V	84	8.4 V	B4	16.0 V	E4	27.5 V		
41	4.1 V	85	8.5 V	B5	16.4 V	E5	28.0 V		
42	4.2 V	86	8.6 V	B6	16.8 V	E6	28.5 V		
43	4.3 V	87	8.7 V	B7	17.2 V	E7	29.0 V		
44	4.4 V	88	8.8 V	B8	17.6 V	E8	29.5 V		
45	4.5 V	89	8.9 V	B9	18.0 V	E9	30.0 V		
46	4.6 V	90	9.0 V	C0	18.4 V				
47	4.7 V	91	9.1 V	C1	18.8 V				
48	4.8 V	92	9.2 V	C2	19.2 V				
49	4.9 V	93	9.3 V	C3	19.6 V				
50	5.0 V	94	9.4 V	C4	20.0 V				
51	5.1 V	95	9.5 V						
52	5.2 V	96	9.6 V						
53	5.3 V	97	9.7 V						
54	5.4 V	98	9.8 V						
55	5.5 V	99	9.9 V						
56	5.6 V	00	10.0 V						
57	5.7 V								
58	5.8 V								
59	5.9 V								
60	6.0 V								

表 11-1. Voltage Options (continued)

100 mV STEPS				400 mV STEPS		500 mV STEPS		1 V STEPS	
NOMEN- CLATURE	VOLTAGE OPTIONS	NOMEN- CLATURE	VOLTAGE OPTIONS	NOMEN- CLATURE	VOLTAGE OPTIONS	NOMEN- CLATURE	VOLTAGE OPTIONS	NOMEN- CLATURE	VOLTAGE OPTIONS
61	6.1 V								
62	6.2 V								
63	6.3 V								
64	6.4 V								
65	6.5 V								
66	6.6 V								
67	6.7 V								
68	6.8 V								
69	6.9 V								

11.2 サポート・リソース

TI E2E™ サポート・フォーラムは、エンジニアが検証済みの回答と設計に関するヒントをエキスパートから迅速かつ直接得ることができる場所です。既存の回答を検索したり、独自の質問をしたりすることで、設計に必要な支援を迅速に得ることができます。

リンクされているコンテンツは、該当する貢献者により、現状のまま提供されるものです。これらは TI の仕様を構成するものではなく、必ずしも TI の見解を反映したものではありません。TI の [使用条件](#) を参照してください。

11.3 Trademarks

TI E2E™ is a trademark of Texas Instruments.

すべての商標は、それぞれの所有者に帰属します。

11.4 静電気放電に関する注意事項



この IC は、ESD によって破損する可能性があります。テキサス・インスツルメンツは、IC を取り扱う際には常に適切な注意を払うことを推奨します。正しい取り扱いおよび設置手順に従わない場合、デバイスを破損するおそれがあります。

ESD による破損は、わずかな性能低下からデバイスの完全な故障まで多岐にわたります。精密な IC の場合、パラメータがわずかに変化するだけで公表されている仕様から外れる可能性があるため、破損が発生しやすくなっています。

11.5 用語集

[テキサス・インスツルメンツ用語集](#)

この用語集には、用語や略語の一覧および定義が記載されています。

PACKAGING INFORMATION

Orderable Device	Status (1)	Package Type	Package Drawing	Pins	Package Qty	Eco Plan (2)	Lead finish/ Ball material (6)	MSL Peak Temp (3)	Op Temp (°C)	Device Marking (4/5)	Samples
TPS37A010122DSKRQ1	ACTIVE	SON	DSK	10	3000	RoHS & Green	NIPDAU	Level-1-260C-UNLIM	-40 to 125	2KDL	Samples
TPS37A010122DYRQ1	ACTIVE	SOT-23-THIN	DYY	14	3000	RoHS & Green	NIPDAU	Level-1-260C-UNLIM	-40 to 125	37A010122Q	Samples
TPS37A372922DYRQ1	ACTIVE	SOT-23-THIN	DYY	14	3000	RoHS & Green	NIPDAU	Level-1-260C-UNLIM	-40 to 125	37A372922Q	Samples
TPS37A543222DSKRQ1	ACTIVE	SON	DSK	10	3000	RoHS & Green	NIPDAU	Level-1-260C-UNLIM	-40 to 125	2KFL	Samples
TPS37AB7806FDSKRQ1	ACTIVE	SON	DSK	10	3000	RoHS & Green	NIPDAU	Level-1-260C-UNLIM	-40 to 125	2PRL	Samples
TPS37EE4554FDSKRQ1	ACTIVE	SON	DSK	10	3000	RoHS & Green	NIPDAU	Level-1-260C-UNLIM	-40 to 125	32JL	Samples

(1) The marketing status values are defined as follows:

ACTIVE: Product device recommended for new designs.

LIFEBUY: TI has announced that the device will be discontinued, and a lifetime-buy period is in effect.

NRND: Not recommended for new designs. Device is in production to support existing customers, but TI does not recommend using this part in a new design.

PREVIEW: Device has been announced but is not in production. Samples may or may not be available.

OBSELETE: TI has discontinued the production of the device.

(2) **RoHS:** TI defines "RoHS" to mean semiconductor products that are compliant with the current EU RoHS requirements for all 10 RoHS substances, including the requirement that RoHS substance do not exceed 0.1% by weight in homogeneous materials. Where designed to be soldered at high temperatures, "RoHS" products are suitable for use in specified lead-free processes. TI may reference these types of products as "Pb-Free".

RoHS Exempt: TI defines "RoHS Exempt" to mean products that contain lead but are compliant with EU RoHS pursuant to a specific EU RoHS exemption.

Green: TI defines "Green" to mean the content of Chlorine (Cl) and Bromine (Br) based flame retardants meet JS709B low halogen requirements of <=1000ppm threshold. Antimony trioxide based flame retardants must also meet the <=1000ppm threshold requirement.

(3) MSL, Peak Temp. - The Moisture Sensitivity Level rating according to the JEDEC industry standard classifications, and peak solder temperature.

(4) There may be additional marking, which relates to the logo, the lot trace code information, or the environmental category on the device.

(5) Multiple Device Markings will be inside parentheses. Only one Device Marking contained in parentheses and separated by a "-" will appear on a device. If a line is indented then it is a continuation of the previous line and the two combined represent the entire Device Marking for that device.

(6) Lead finish/Ball material - Orderable Devices may have multiple material finish options. Finish options are separated by a vertical ruled line. Lead finish/Ball material values may wrap to two lines if the finish value exceeds the maximum column width.

Important Information and Disclaimer: The information provided on this page represents TI's knowledge and belief as of the date that it is provided. TI bases its knowledge and belief on information provided by third parties, and makes no representation or warranty as to the accuracy of such information. Efforts are underway to better integrate information from third parties. TI has taken and continues to take reasonable steps to provide representative and accurate information but may not have conducted destructive testing or chemical analysis on incoming materials and chemicals. TI and TI suppliers consider certain information to be proprietary, and thus CAS numbers and other limited information may not be available for release.

In no event shall TI's liability arising out of such information exceed the total purchase price of the TI part(s) at issue in this document sold by TI to Customer on an annual basis.

OTHER QUALIFIED VERSIONS OF TPS37-Q1 :

- Catalog : [TPS37](#)

NOTE: Qualified Version Definitions:

- Catalog - TI's standard catalog product

TAPE AND REEL INFORMATION

QUADRANT ASSIGNMENTS FOR PIN 1 ORIENTATION IN TAPE

*All dimensions are nominal

Device	Package Type	Package Drawing	Pins	SPQ	Reel Diameter (mm)	Reel Width W1 (mm)	A0 (mm)	B0 (mm)	K0 (mm)	P1 (mm)	W (mm)	Pin1 Quadrant
TPS37A010122DSKRQ1	SON	DSK	10	3000	180.0	8.4	2.8	2.8	1.0	4.0	8.0	Q2
TPS37A010122DYRQ1	SOT-23-THIN	DYY	14	3000	330.0	12.4	4.8	3.6	1.6	8.0	12.0	Q3
TPS37A372922DYRQ1	SOT-23-THIN	DYY	14	3000	330.0	12.4	4.8	3.6	1.6	8.0	12.0	Q3
TPS37A543222DSKRQ1	SON	DSK	10	3000	180.0	8.4	2.8	2.8	1.0	4.0	8.0	Q2
TPS37AB7806FDSKRQ1	SON	DSK	10	3000	180.0	8.4	2.8	2.8	1.0	4.0	8.0	Q2
TPS37EE4554FDSKRQ1	SON	DSK	10	3000	180.0	8.4	2.8	2.8	1.0	4.0	8.0	Q2

TAPE AND REEL BOX DIMENSIONS

*All dimensions are nominal

Device	Package Type	Package Drawing	Pins	SPQ	Length (mm)	Width (mm)	Height (mm)
TPS37A010122DSKRQ1	SON	DSK	10	3000	210.0	185.0	35.0
TPS37A010122DYRQ1	SOT-23-THIN	DYY	14	3000	336.6	336.6	31.8
TPS37A372922DYRQ1	SOT-23-THIN	DYY	14	3000	336.6	336.6	31.8
TPS37A543222DSKRQ1	SON	DSK	10	3000	210.0	185.0	35.0
TPS37AB7806FDSKRQ1	SON	DSK	10	3000	210.0	185.0	35.0
TPS37EE4554FDSKRQ1	SON	DSK	10	3000	210.0	185.0	35.0

GENERIC PACKAGE VIEW

DSK 10

WSON - 0.8 mm max height

2.5 x 2.5 mm, 0.5 mm pitch

PLASTIC SMALL OUTLINE - NO LEAD

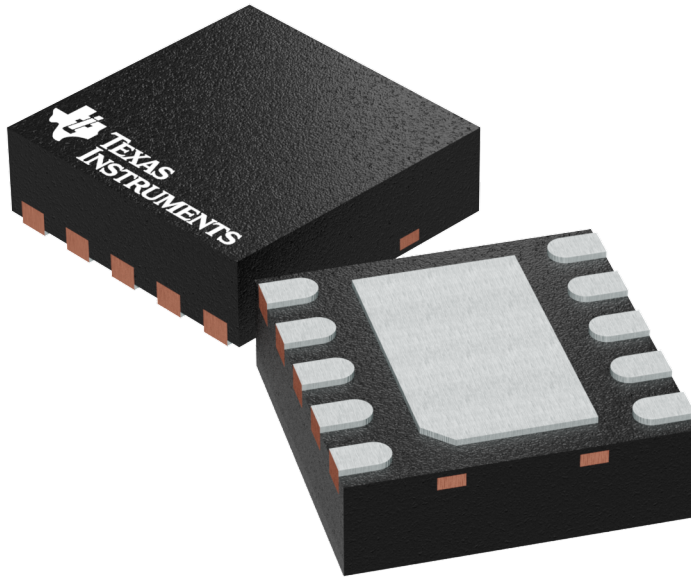

Images above are just a representation of the package family, actual package may vary.
Refer to the product data sheet for package details.

4225304/A

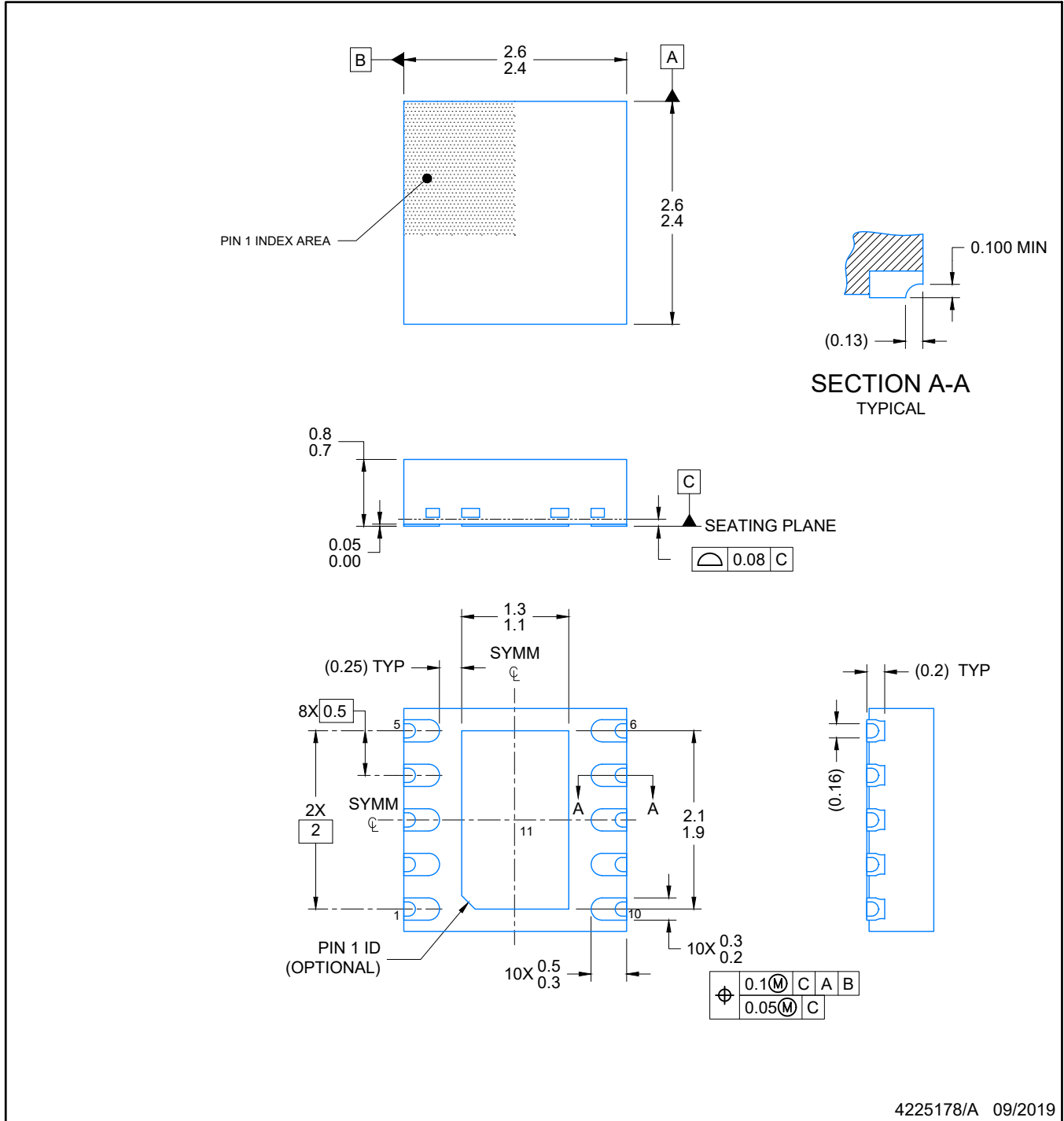

NOTES:

1. All linear dimensions are in millimeters. Any dimensions in parenthesis are for reference only. Dimensioning and tolerancing per ASME Y14.5M.
2. This drawing is subject to change without notice.
3. The package thermal pad must be soldered to the printed circuit board for optimal thermal and mechanical performance.

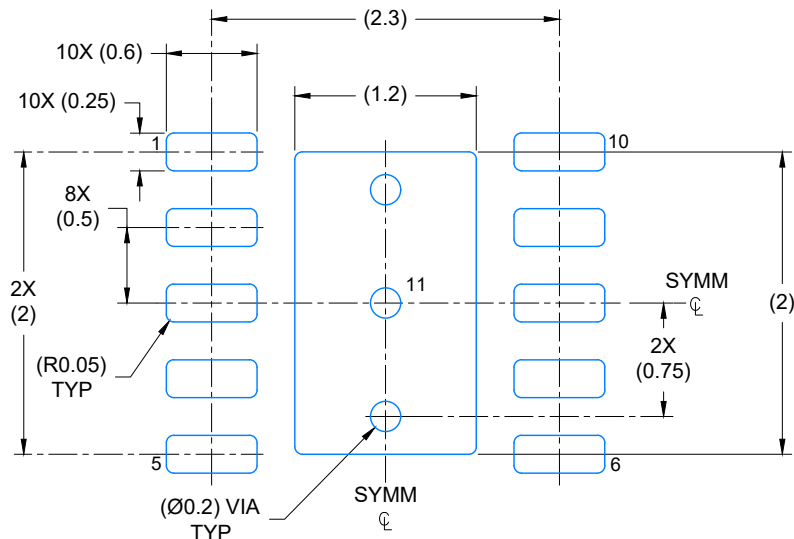

LAND PATTERN EXAMPLE

EXPOSED METAL SHOWN
SCALE: 20X

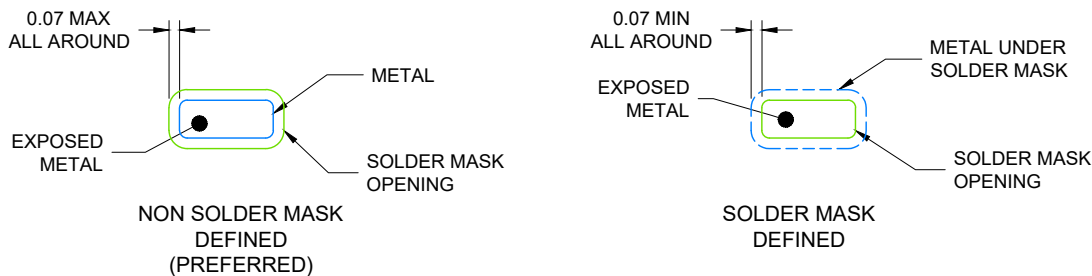

SOLDER MASK DETAILS

4225178/A 09/2019

NOTES: (continued)

4. This package is designed to be soldered to a thermal pad on the board. For more information, see Texas Instruments literature number SLUA271 (www.ti.com/lit/sluea271).
5. Vias are optional depending on application, refer to device data sheet. If any vias are implemented, refer to their locations shown on this view. It is recommended that vias under paste be filled, plugged or tented.

EXAMPLE STENCIL DESIGN

DSK0010C

WSON - 0.8 mm max height

PLASTIC QUAD FLAT PACK- NO LEAD

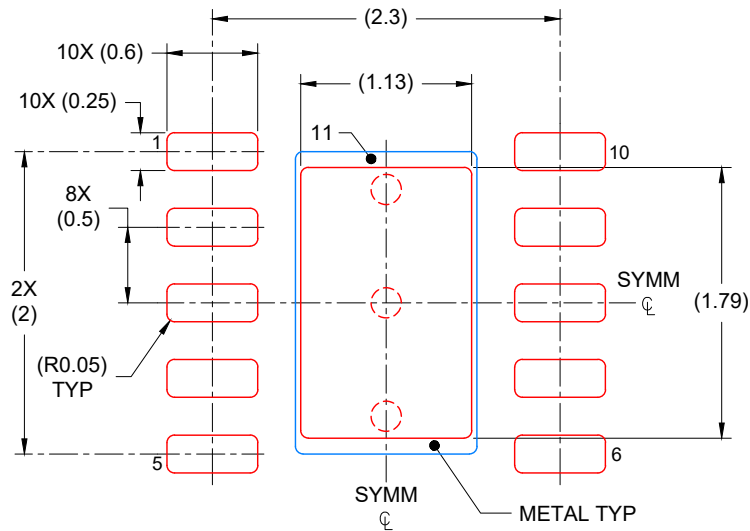

SOLDER PASTE EXAMPLE
BASED ON 0.125 mm THICK STENCIL

EXPOSED PAD
84% PRINTED COVERAGE BY AREA
SCALE: 20X

4225178/A 09/2019

NOTES: (continued)

6. Laser cutting apertures with trapezoidal walls and rounded corners may offer better paste release. IPC-7525 may have alternate design recommendations.

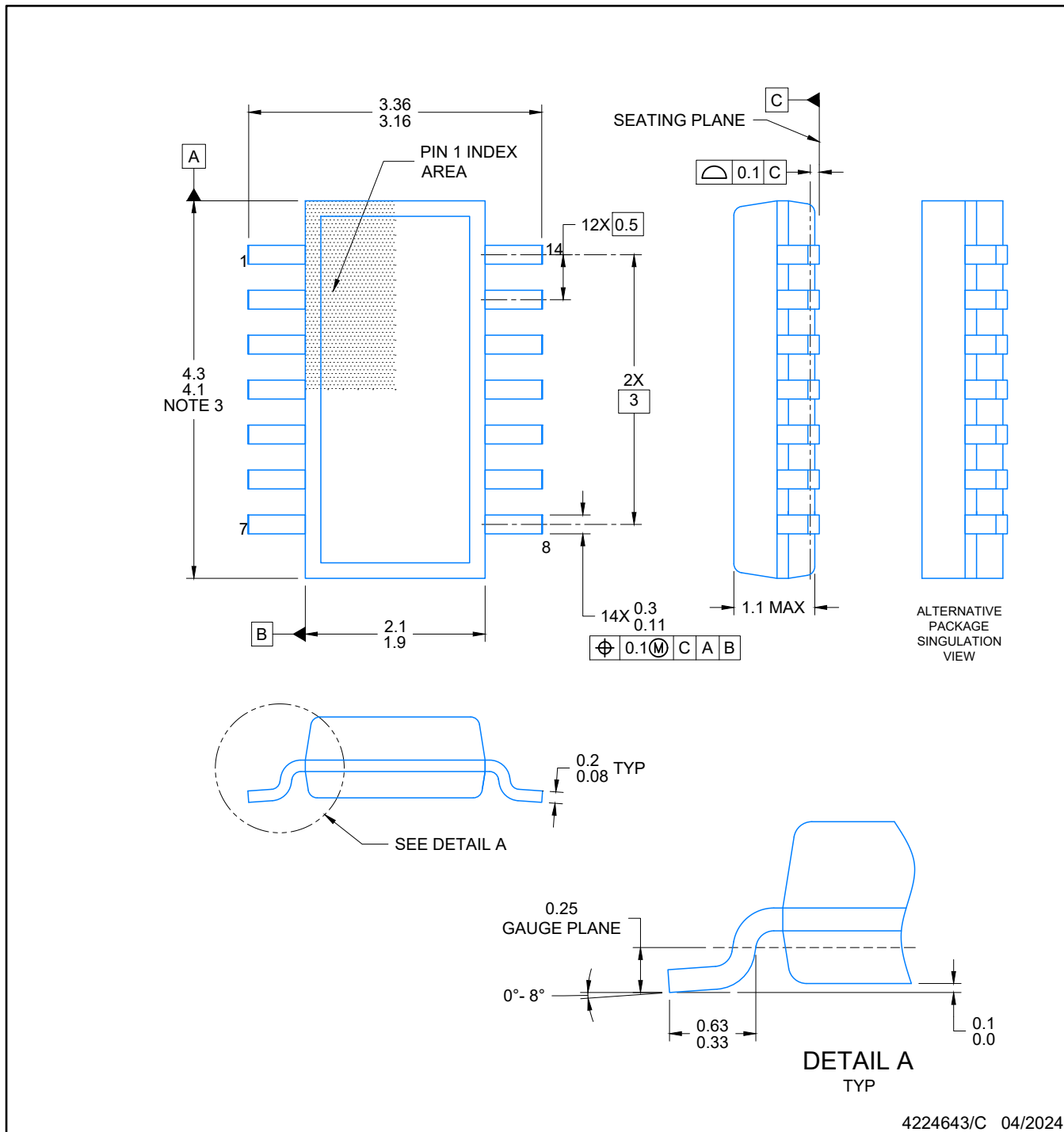

4224643/C 04/2024

NOTES:

1. All linear dimensions are in millimeters. Any dimensions in parenthesis are for reference only. Dimensioning and tolerancing per ASME Y14.5M.
2. This drawing is subject to change without notice.
3. This dimension does not include mold flash, protrusions, or gate burrs. Mold flash, protrusions, or gate burrs shall not exceed 0.15 per side.
4. This dimension does not include interlead flash. Interlead flash shall not exceed 0.50 per side.
5. Reference JEDEC Registration MO-345, Variation AB

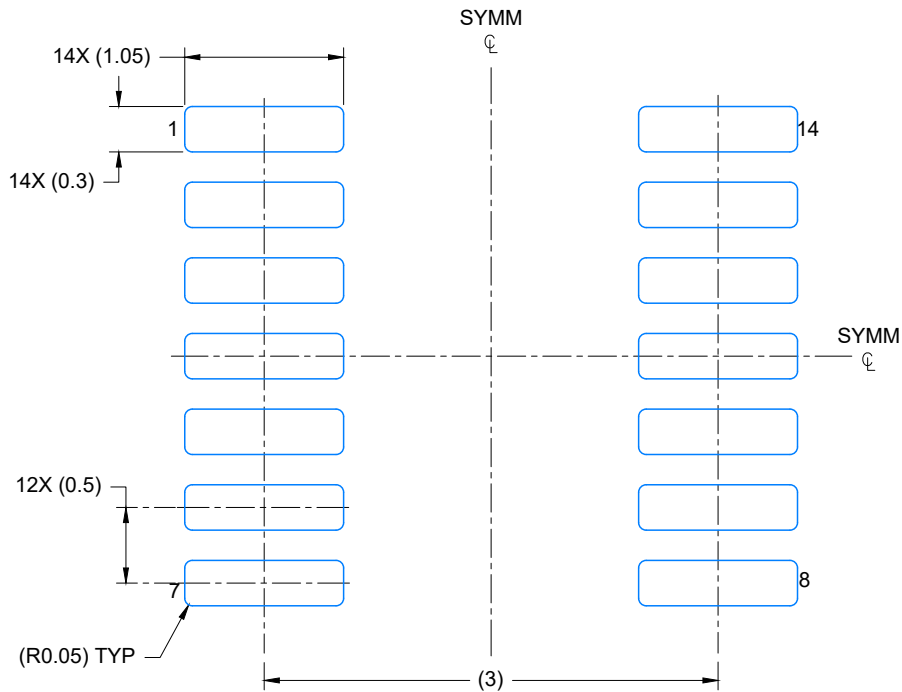

LAND PATTERN EXAMPLE
EXPOSED METAL SHOWN
SCALE: 20X

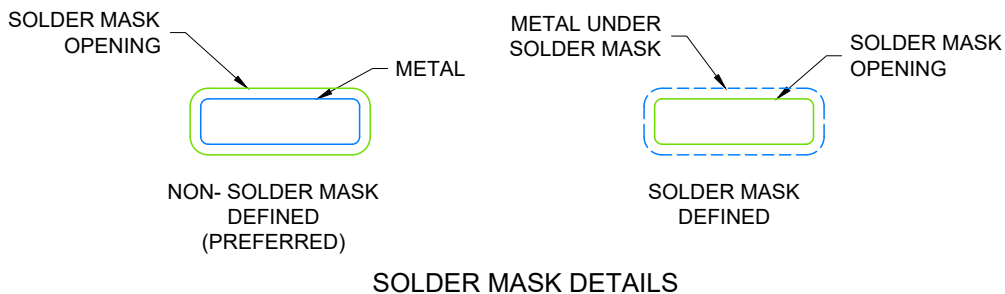

4224643/C 04/2024

NOTES: (continued)

- 6. Publication IPC-7351 may have alternate designs.
- 7. Solder mask tolerances between and around signal pads can vary based on board fabrication site.

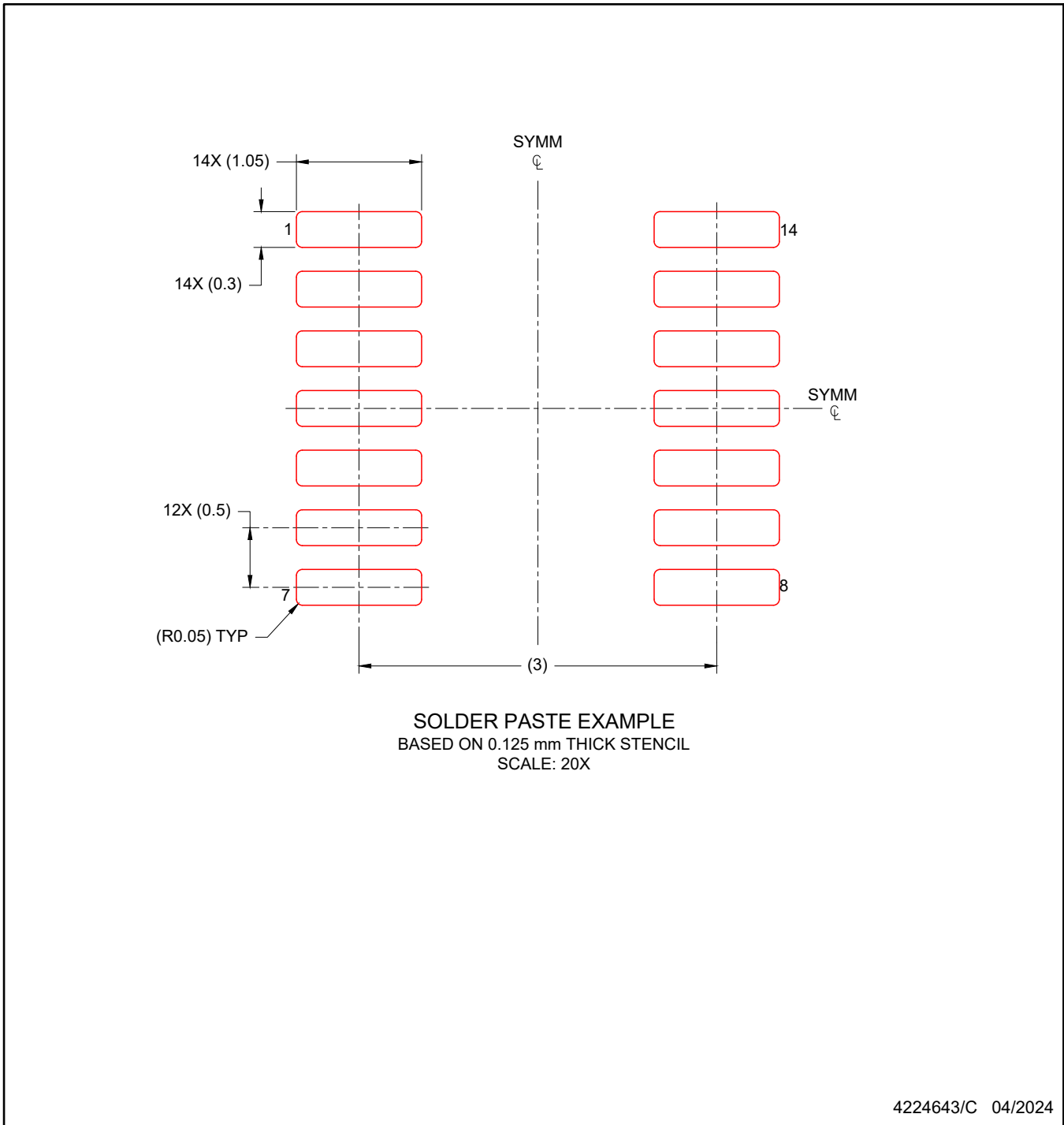

NOTES: (continued)

- 8. Laser cutting apertures with trapezoidal walls and rounded corners may offer better paste release. IPC-7525 may have alternate design recommendations.
- 9. Board assembly site may have different recommendations for stencil design.

重要なお知らせと免責事項

TI は、技術データと信頼性データ (データシートを含みます)、設計リソース (リファレンス・デザインを含みます)、アプリケーションや設計に関する各種アドバイス、Web ツール、安全性情報、その他のリソースを、欠陥が存在する可能性のある「現状のまま」提供しており、商品性および特定目的に対する適合性の黙示保証、第三者の知的財産権の非侵害保証を含むいかなる保証も、明示的または黙示的にかかわらず拒否します。

これらのリソースは、TI 製品を使用する設計の経験を積んだ開発者への提供を意図したものです。(1) お客様のアプリケーションに適した TI 製品の選定、(2) お客様のアプリケーションの設計、検証、試験、(3) お客様のアプリケーションに該当する各種規格や、その他のあらゆる安全性、セキュリティ、規制、または他の要件への確実な適合に関する責任を、お客様のみが単独で負うものとし、

上記の各種リソースは、予告なく変更される可能性があります。これらのリソースは、リソースで説明されている TI 製品を使用するアプリケーションの開発の目的でのみ、TI はその使用をお客様に許諾します。これらのリソースに関して、他の目的で複製することや掲載することは禁止されています。TI や第三者の知的財産権のライセンスが付与されている訳ではありません。お客様は、これらのリソースを自身で使用した結果発生するあらゆる申し立て、損害、費用、損失、責任について、TI およびその代理人を完全に補償するものとし、TI は一切の責任を拒否します。

TI の製品は、[TI の販売条件](#)、または [ti.com](#) やかかる TI 製品の関連資料などのいずれかを通じて提供する適用可能な条項の下で提供されています。TI がこれらのリソースを提供することは、適用される TI の保証または他の保証の放棄の拡大や変更を意味するものではありません。

お客様がいかなる追加条項または代替条項を提案した場合でも、TI はそれらに異議を唱え、拒否します。

郵送先住所 : Texas Instruments, Post Office Box 655303, Dallas, Texas 75265
Copyright © 2024, Texas Instruments Incorporated