

# TPS3851-Q1 高精度電圧スーパーバイザ、ウォッチドッグ・タイマ内蔵

## 1 特長

- 下記内容で AEC-Q100 認定済み:
  - デバイス温度グレード 1:  $-40^{\circ}\text{C}$  ~  $125^{\circ}\text{C}$  の動作時周囲温度範囲
  - デバイス HBM ESD 分類レベル 2
  - デバイス CDM ESD 分類レベル C4B
- 機能安全対応
  - 機能安全システムの設計に役立つ資料を利用可能
- 入力電圧範囲:  $V_{DD} = 1.6\text{V} \sim 6.5\text{V}$
- 0.8% の電圧スレッシュホールド精度
- 低消費電流:  $I_{DD} = 10\mu\text{A}$  (標準値)
- ウォッチドッグのタイムアウトをユーザーがプログラム可能
- 高精度のウォッチドッグおよびリセット・タイマを製造時にプログラム可能
- マニュアル・リセット入力 ( $\overline{\text{MR}}$ )
- オープン・ドレイン出力
- 高精度の低電圧監視
  - $1.8\text{V} \sim 5.0\text{V}$  の共通レールをサポート
  - 4% および 7% の低電圧スレッシュホールドを利用可能
  - 0.5% のヒステリシス
- ウォッチドッグのディスエーブル機能
- 3mm × 3mm の小型 8 ピン VSON パッケージで供給

## 2 アプリケーション

- サラウンド・ビュー・システムの ECU
- 車両占有検出センサ
- ADAS ドメイン・コントローラ
- 車載用 DC/DC コンバータ
- 車載用フロント・カメラ
- 車載センター情報ディスプレイ

## 3 概要

TPS3851-Q1 は、高精度の電圧スーパーバイザとプログラム可能なウォッチドッグ・タイマを組み合わせた製品です。TPS3851-Q1 のコンパレータは、VDD ピンの低電圧 ( $V_{ITN}$ ) スレッシュホールドについて 0.8% の精度を実現します ( $-40^{\circ}\text{C} \sim +125^{\circ}\text{C}$ )。また、TPS3851-Q1 には低電圧スレッシュホールドの正確なヒステリシスも内蔵されており、許容誤差の厳しいシステムに理想的です。スーパーバイザの  $\overline{\text{RESET}}$  遅延は 15% の精度で、高精度の遅延タイミングです。

TPS3851-Q1 にはプログラム可能なウォッチドッグ・タイマが内蔵されており、広範囲なアプリケーションに使用できます。専用ウォッチドッグ出力 ( $\overline{\text{WDO}}$ ) により分解能が向上し、フォルト状況の性質を判定するために役立ちます。ウォッチドッグのタイムアウトは、外付けのコンデンサ、または工場プログラムされるデフォルトの遅延設定によりプログラム可能です。ウォッチドッグはロジック・ピンによりディスエーブルできるため、開発プロセスにおいて望ましくないウォッチドッグのタイムアウトを回避できます。

TPS3851-Q1 は、小型の

3.00mm × 3.00mm、8 ピンの VSON パッケージで供給されます。TPS3851-Q1 はウェットアブル・フランクを採用し、光学検査を容易に行えます。

### 製品情報

部品番号	パッケージ (1)	本体サイズ (公称)
TPS3851-Q1	VSON (8)	3.00mm × 3.00mm

- (1) 利用可能なすべてのパッケージについては、このデータシートの末尾にある注文情報を参照してください。

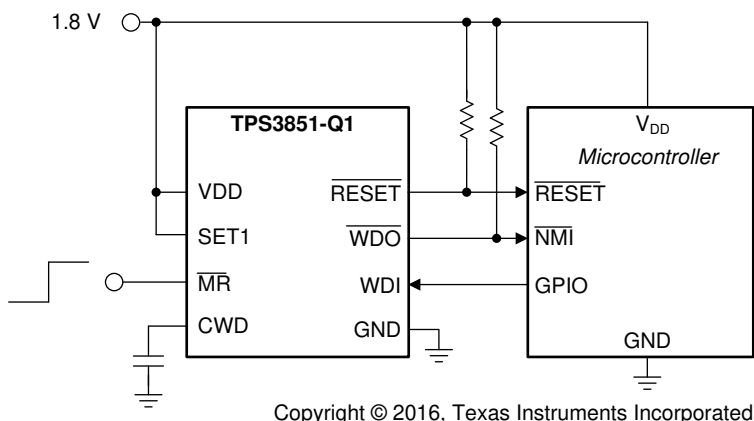

完全に統合されたマイコン監視回路

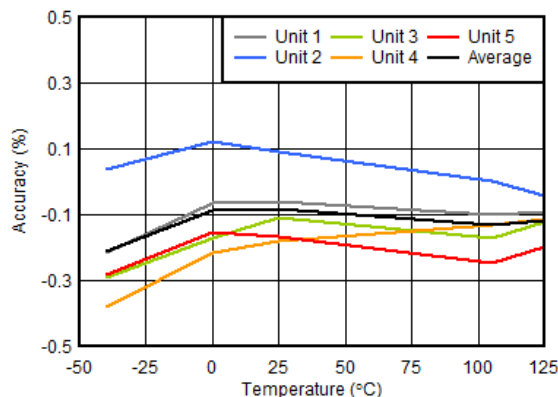

低電圧スレッシュホールド ( $V_{ITN}$ ) の精度と温度との関係



## Table of Contents

<b>1</b> 特長.....	1	7.4 Device Functional Modes.....	14
<b>2</b> アプリケーション.....	1	<b>8 Application and Implementation</b> .....	15
<b>3</b> 概要.....	1	8.1 Application Information.....	15
<b>4 Revision History</b> .....	2	8.2 Typical Application.....	18
<b>5 Pin Configuration and Functions</b> .....	3	<b>9 Power Supply Recommendations</b> .....	21
<b>6 Specifications</b> .....	4	<b>10 Layout</b> .....	22
6.1 Absolute Maximum Ratings.....	4	10.1 Layout Guidelines.....	22
6.2 ESD Ratings.....	4	10.2 Layout Example.....	22
6.3 Recommended Operating Conditions.....	4	<b>11 Device and Documentation Support</b> .....	23
6.4 Thermal Information.....	5	11.1 Device Support.....	23
6.5 Electrical Characteristics.....	5	11.2 Documentation Support.....	23
6.6 Timing Requirements.....	6	11.3 Receiving Notification of Documentation Updates..	23
6.7 Timing Diagrams.....	7	11.4 サポート・リソース.....	23
6.8 Typical Characteristics.....	8	11.5 Trademarks.....	23
<b>7 Detailed Description</b> .....	11	11.6 Electrostatic Discharge Caution.....	23
7.1 Overview.....	11	11.7 Glossary.....	23
7.2 Functional Block Diagram.....	11	<b>12 Mechanical, Packaging, and Orderable Information</b> .....	24
7.3 Feature Description.....	11		

## 4 Revision History

資料番号末尾の英字は改訂を表しています。その改訂履歴は英語版に準じています。

<b>Changes from Revision * (March 2017) to Revision A (September 2021)</b>	<b>Page</b>
• 文書全体にわたって表、図、相互参照の採番方法を更新.....	1
• 「ウォッチドッグ・タイムアウトおよびウォッチドッグ・リセット遅延の温度範囲全体にわたる精度:±15%」を削除.....	1
• 「機能安全対応」の箇条書き項目を追加.....	1
• 文書全体にわたって表、図、相互参照の採番方法を更新.....	1
• 分かりやすくするために「VDD ピンの」を追加.....	1
• Updated ESD Ratings.....	4
• Updated I <sub>CWD</sub> min and max spec.....	5
• Updated V <sub>CWD</sub> min and max spec.....	5
• Added a footnote to for t <sub>NIT</sub> .....	6
• Updated t <sub>W<sub>DU</sub></sub> min and max boundry values from 0.85 and 1.15 to 0.905 and 1.095 respectively.....	16
• Updated t <sub>W<sub>DU</sub></sub> min and max values for all capacitors.....	16
• Updated the equations 6 and 7 to replace 0.85 and 1.15 to 0.905 and 1.095 respectively.....	19

## 5 Pin Configuration and Functions

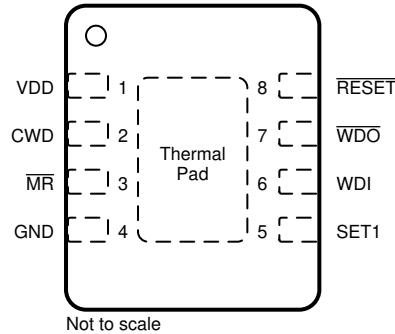

**图 5-1. DRB Package**  
**3-mm × 3-mm, 8-Pin VSON**  
**Top View**

**表 5-1. Pin Functions**

NAME	NO.	I/O	DESCRIPTION
CWD	2	I	Programmable watchdog timeout input. The watchdog timeout is set by connecting a capacitor between this pin and ground. Connecting via a 10-kΩ resistor to $V_{DD}$ or leaving unconnected further enables the selection of the preset watchdog timeouts; see the <a href="#">CWD Functionality</a> section. The TPS3851-Q1 determines the watchdog timeout using either <a href="#">Equation 1</a> or <a href="#">Equation 2</a> with standard or extended timing, respectively.
GND	4	—	Ground pin
MR	3	I	Manual reset pin. A logical low on this pin issues a $\overline{\text{RESET}}$ . This pin is internally pulled up to $V_{DD}$ . $\overline{\text{RESET}}$ remains low for a fixed reset delay ( $t_{RST}$ ) time after $\overline{\text{MR}}$ is deasserted (high).
RESET	8	O	Reset output. Connect $\overline{\text{RESET}}$ using a 1-kΩ to 100-kΩ resistor to the correct pullup voltage rail ( $V_{PU}$ ). $\overline{\text{RESET}}$ goes low when $V_{DD}$ goes below the undervoltage threshold ( $V_{ITN}$ ). When $V_{DD}$ is within the normal operating range, the $\overline{\text{RESET}}$ timeout-counter starts. At completion, $\overline{\text{RESET}}$ goes high. During startup, the state of $\overline{\text{RESET}}$ is undefined below the specified power-on-reset (POR) voltage ( $V_{POR}$ ). Above POR, $\overline{\text{RESET}}$ goes low and remains low until the monitored voltage is within the correct operating range (above $V_{ITN} + V_{HYST}$ ) and the $\overline{\text{RESET}}$ timeout is complete.
SET1	5	I	Logic input. Grounding the SET1 pin disables the watchdog timer. SET1 and CWD select the watchdog timeouts; see the <a href="#">SET1</a> section.
VDD	1	I	Supply voltage pin. For noisy systems, connecting a 0.1-μF bypass capacitor is recommended.
WDI	6	I	Watchdog input. A falling edge must occur at WDI before the timeout ( $t_{WD}$ ) expires. When the watchdog is not in use, the SET1 pin can be used to disable the watchdog. WDI is ignored when $\overline{\text{RESET}}$ or $\overline{\text{WDO}}$ are low (asserted) and when the watchdog is disabled. If the watchdog is disabled, WDI cannot be left unconnected and must be driven to either $V_{DD}$ or GND.
WDO	7	O	Watchdog output. Connect $\overline{\text{WDO}}$ with a 1-kΩ to 100-kΩ resistor to the correct pullup voltage rail ( $V_{PU}$ ). $\overline{\text{WDO}}$ goes low (asserts) when a watchdog timeout occurs. $\overline{\text{WDO}}$ only asserts when $\overline{\text{RESET}}$ is high. When a watchdog timeout occurs, $\overline{\text{WDO}}$ goes low (asserts) for the set $\overline{\text{RESET}}$ timeout delay ( $t_{RST}$ ). When $\overline{\text{RESET}}$ goes low, $\overline{\text{WDO}}$ is in a high-impedance state.
Thermal pad		—	Connect the thermal pad to a large-area ground plane. The thermal pad is internally connected to GND.

## 6 Specifications

### 6.1 Absolute Maximum Ratings

over operating free-air temperature range (unless otherwise noted) <sup>(1)</sup>

		MIN	MAX	UNIT
Supply voltage range	VDD	-0.3	7	V
Output voltage range	RESET, WDO	-0.3	7	V
Voltage ranges	SET1, WDI, MR	-0.3	7	V
	CWD	-0.3	V <sub>DD</sub> + 0.3 <sup>(3)</sup>	
Output pin current	RESET, WDO		±20	mA
Input current (all pins)			±20	mA
Continuous total power dissipation		See <a href="#">セクション 6.4</a>		
Temperature	Operating junction, T <sub>J</sub> <sup>(2)</sup>	-40	150	°C
	Operating free-air, T <sub>A</sub> <sup>(2)</sup>	-40	150	
	Storage, T <sub>stg</sub>	-65	150	

- (1) Stresses beyond those listed under *Absolute Maximum Ratings* may cause permanent damage to the device. These are stress ratings only, which do not imply functional operation of the device at these or any other conditions beyond those indicated under *Recommended Operating Conditions*. Exposure to absolute-maximum-rated conditions for extended periods may affect device reliability.
- (2) Assume that T<sub>J</sub> = T<sub>A</sub> as a result of the low dissipated power in this device.
- (3) The absolute maximum rating is V<sub>DD</sub> + 0.3 V or 7.0 V, whichever is smaller.

### 6.2 ESD Ratings

		VALUE	UNIT
V <sub>(ESD)</sub> Electrostatic discharge	Human-body model (HBM), per AEC Q100-002 <sup>(1)</sup>	±4000	V
	Charged-device model (CDM), per AEC Q100-011	±1000	

- (1) AEC Q100-002 indicates that HBM stressing shall be in accordance with the ANSI/ESDA/JEDEC JS-001 specification.

### 6.3 Recommended Operating Conditions

over operating free-air temperature range (unless otherwise noted)

		MIN	TYP	MAX	UNIT
V <sub>DD</sub>	Supply pin voltage	1.6		6.5	V
V <sub>SET1</sub>	SET1 pin voltage	0		6.5	V
C <sub>CWD</sub>	Watchdog timing capacitor	0.1 <sup>(1)</sup> <sup>(2)</sup>		1000 <sup>(1)</sup> <sup>(2)</sup>	nF
CWD	Pullup resistor to VDD	9	10	11	kΩ
R <sub>PU</sub>	Pullup resistor, RESET and WDO	1	10	100	kΩ
I <sub>RESET</sub>	RESET pin current			10	mA
I <sub>WDO</sub>	Watchdog output current			10	mA
T <sub>J</sub>	Junction temperature	-40		125	°C

- (1) Using standard timing with a C<sub>CWD</sub> capacitor of 0.1 nF or 1000 nF gives a t<sub>WD(typ)</sub> of 0.704 ms or 3.23 seconds, respectively.
- (2) Using extended timing with a C<sub>CWD</sub> capacitor of 0.1 nF or 1000 nF gives a t<sub>WD(typ)</sub> of 62.74 ms or 77.45 seconds, respectively.

## 6.4 Thermal Information

THERMAL METRIC <sup>(1)</sup>		TPS3851-Q1	UNIT
		DRB (VSON)	
		8 PINS	
R <sub>θJA</sub>	Junction-to-ambient thermal resistance	47.7	°C/W
R <sub>θJC(top)</sub>	Junction-to-case (top) thermal resistance	51.5	°C/W
R <sub>θJB</sub>	Junction-to-board thermal resistance	22.2	°C/W
ψ <sub>JT</sub>	Junction-to-top characterization parameter	1.3	°C/W
ψ <sub>JB</sub>	Junction-to-board characterization parameter	22.3	°C/W
R <sub>θJC(bot)</sub>	Junction-to-case (bottom) thermal resistance	4.3	°C/W

(1) For more information about traditional and new thermal metrics, see the [Semiconductor and IC Package Thermal Metrics](#) application report.

## 6.5 Electrical Characteristics

at  $V_{ITN} + V_{HYST} \leq V_{DD} \leq 6.5$  V over the operating temperature range of  $-40^{\circ}\text{C} \leq T_A, T_A \leq 125^{\circ}\text{C}$  (unless otherwise noted); the open-drain pullup resistors are 10 kΩ for each output; typical values are at  $T_A = 25^{\circ}\text{C}$

PARAMETER	TEST CONDITIONS	MIN	TYP	MAX	UNIT			
<b>GENERAL CHARACTERISTICS</b>								
V <sub>DD</sub> <sup>(1) (2) (3)</sup>	Supply voltage	1.6		6.5	V			
I <sub>DD</sub>	Supply current		10	19	μA			
<b>RESET FUNCTION</b>								
V <sub>POR</sub> <sup>(2)</sup>	Power-on reset voltage	I <sub>RESET</sub> = 15 μA, V <sub>OL(MAX)</sub> = 0.25 V			0.8	V		
V <sub>UVLO</sub> <sup>(1)</sup>	Undervoltage lockout voltage		1.35		V			
V <sub>ITN</sub>	Undervoltage threshold accuracy, entering RESET	V <sub>DD</sub> falling	V <sub>ITN</sub> - 0.8%	V <sub>ITN</sub> + 0.8%				
V <sub>HYST</sub>	Hysteresis voltage	V <sub>DD</sub> rising	0.2%	0.5%	0.8%			
I <sub>MR</sub>	MR pin internal pullup current	V <sub>MR</sub> = 0 V	500	620	700	nA		
<b>WATCHDOG FUNCTION</b>								
I <sub>CWD</sub>	CWD pin charge current	CWD = 0.5 V			347	375	403	nA
V <sub>CWD</sub>	CWD pin threshold voltage		1.196	1.21	1.224	V		
V <sub>OL</sub>	RESET, W <sub>D</sub> O output low	V <sub>DD</sub> = 5 V, I <sub>SINK</sub> = 3 mA			0.4	V		
I <sub>D</sub>	RESET, W <sub>D</sub> O output leakage current, open-drain	V <sub>DD</sub> = V <sub>ITN</sub> + V <sub>HYST</sub> , V <sub>RESET</sub> = V <sub>WDO</sub> = 6.5 V			1	μA		
V <sub>IL</sub>	Low-level input voltage (MR, SET1)			0.25	V			
V <sub>IH</sub>	High-level input voltage (MR, SET1)		0.8		V			
V <sub>IL(WDI)</sub>	Low-level input voltage (WDI)			0.3 × V <sub>DD</sub>	V			
V <sub>IH(WDI)</sub>	High-level input voltage (WDI)		0.8 × V <sub>DD</sub>		V			

(1) When V<sub>DD</sub> falls below V<sub>UVLO</sub>, RESET is driven low.

(2) When V<sub>DD</sub> falls below V<sub>POR</sub>, RESET and W<sub>D</sub>O are undefined.

(3) During power-on, V<sub>DD</sub> must be a minimum 1.6 V for at least 300 μs before RESET correlates with V<sub>DD</sub>.

## 6.6 Timing Requirements

at  $V_{ITN} + V_{HYST} \leq V_{DD} \leq 6.5$  V over the operating temperature range of  $-40^{\circ}\text{C} \leq T_A$ ,  $T_A \leq 125^{\circ}\text{C}$  (unless otherwise noted); the open-drain pullup resistors are 10 k $\Omega$  for each output; typical values are at  $T_A = 25^{\circ}\text{C}$

		MIN	NOM	MAX	UNIT	
<b>GENERAL</b>						
$t_{INIT}$	CWD pin evaluation period <sup>(1)</sup>		381		$\mu\text{s}$	
	Minimum $\overline{\text{MR}}$ , SET1 pin pulse duration		1		$\mu\text{s}$	
	Startup delay <sup>(3)</sup>		300		$\mu\text{s}$	
<b>RESET FUNCTION</b>						
$t_{RST}$	Reset timeout period	170	200	230	ms	
$t_{RST-DEL}$	$V_{DD}$ to RESET delay	$V_{DD} = V_{ITN} + V_{HYST} + 2.5\%$	35		$\mu\text{s}$	
		$V_{DD} = V_{ITN} - 2.5\%$	17			
$t_{MR-DEL}$	$\overline{\text{MR}}$ to RESET delay		200		ns	
<b>WATCHDOG FUNCTION</b>						
$t_{WD}$	Watchdog timeout <sup>(3)</sup>	CWD = NC, SET1 = 0 <sup>(2)</sup>	Watchdog disabled			
		CWD = NC, SET1 = 1 <sup>(2)</sup>	1360	1600	1840	ms
		CWD = 10 k $\Omega$ to VDD, SET1 = 0 <sup>(2)</sup>	Watchdog disabled			
		CWD = 10 k $\Omega$ to VDD, SET1 = 1 <sup>(2)</sup>	170	200	230	ms
$t_{WD-setup}$	Setup time required for device to respond to changes on WDI after being enabled		150		$\mu\text{s}$	
		Minimum WDI pulse duration		50	ns	
$t_{WD-del}$	WDI to WDO delay		50		ns	

(1) Refer to [セクション 8.1.1.2](#)

(2) SET1 = 0 means  $V_{SET1} < V_{IL}$ ; SET1 = 1 means  $V_{SET1} > V_{IH}$ .

(3) The fixed watchdog timing covers both standard and extended versions.

## 6.7 Timing Diagrams

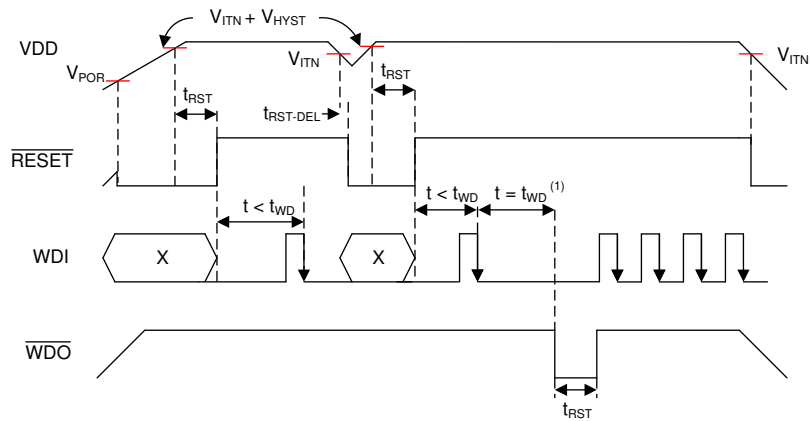

A. See [6-2](#) for WDI timing requirements.

**6-1. Timing Diagram**

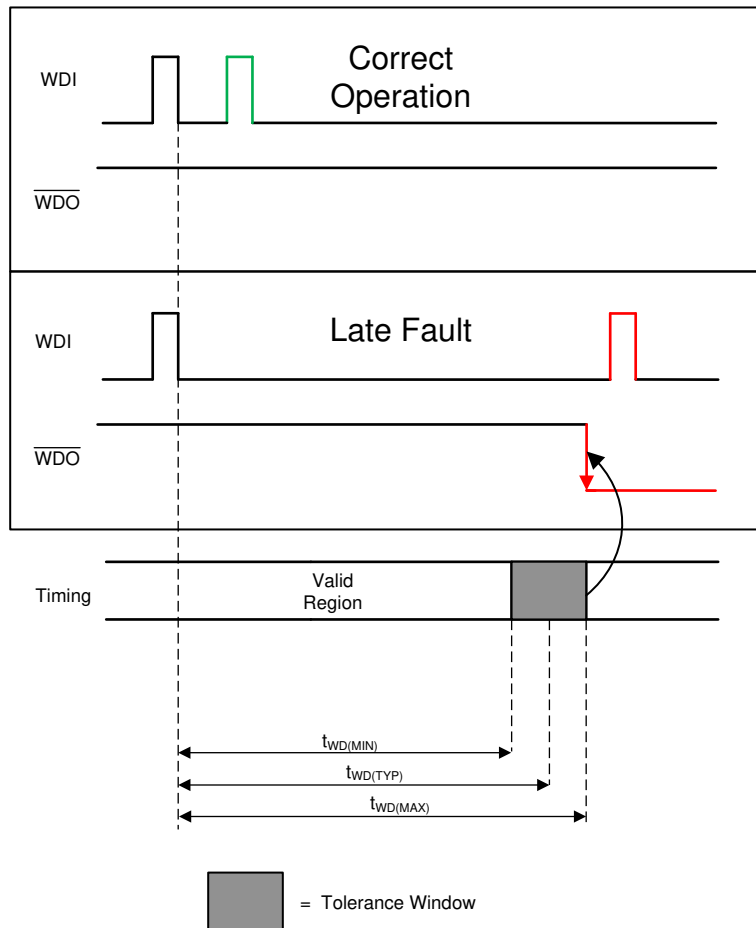

**6-2. Watchdog Timing Diagram**

## 6.8 Typical Characteristics

all typical characteristics curves are taken at 25°C with 1.6 V ≤ V<sub>DD</sub> ≤ 6.5 V (unless other wise noted)

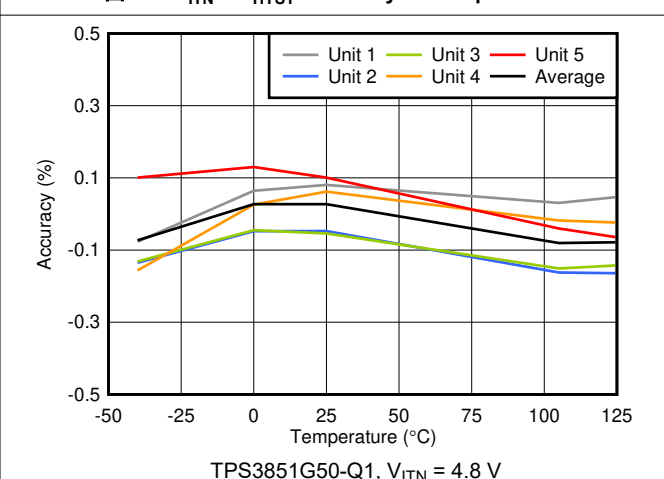
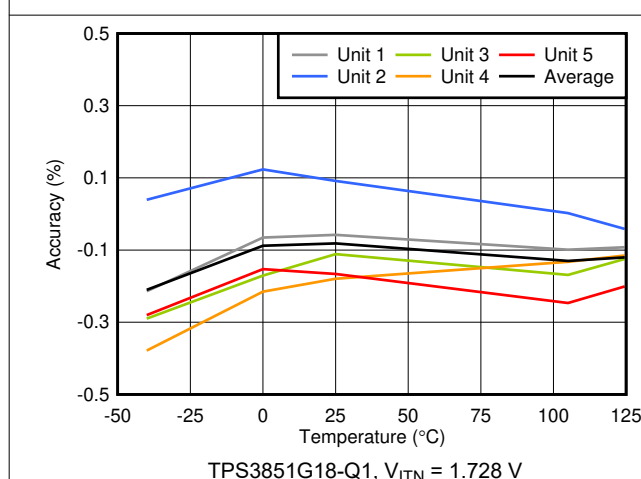
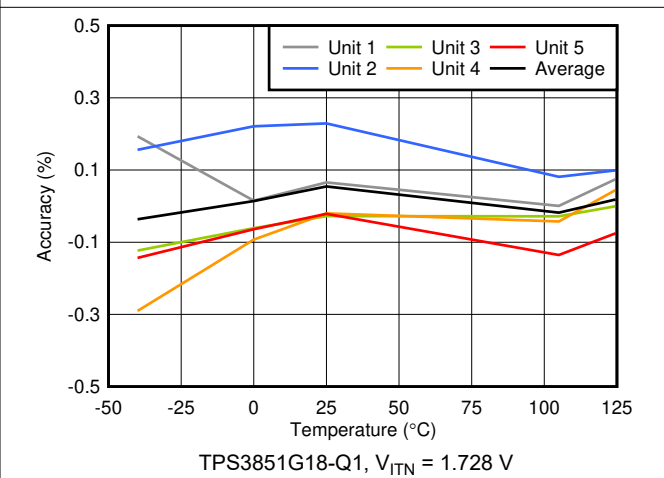
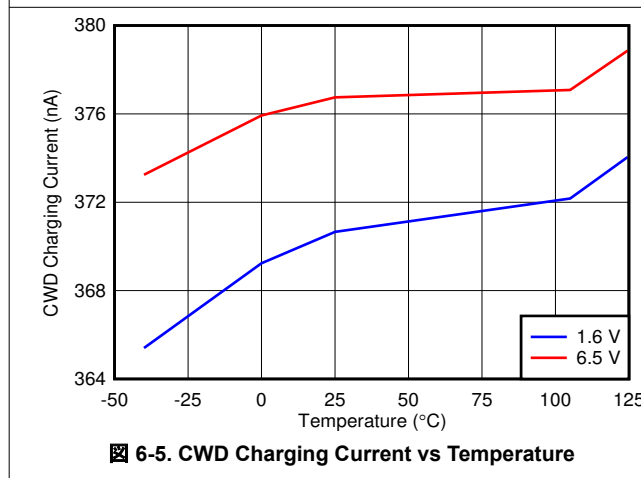
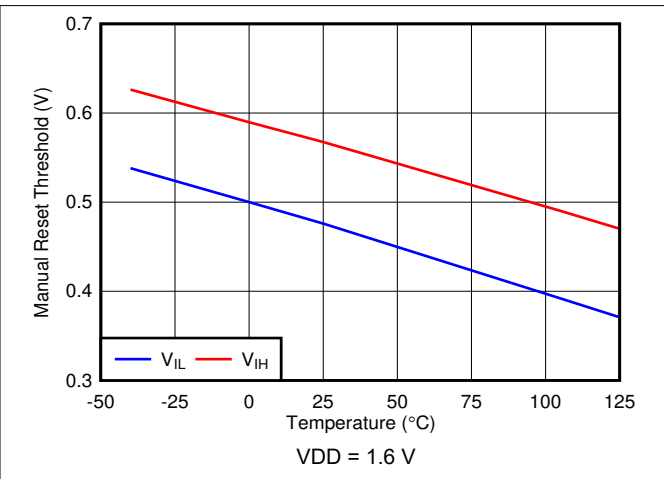
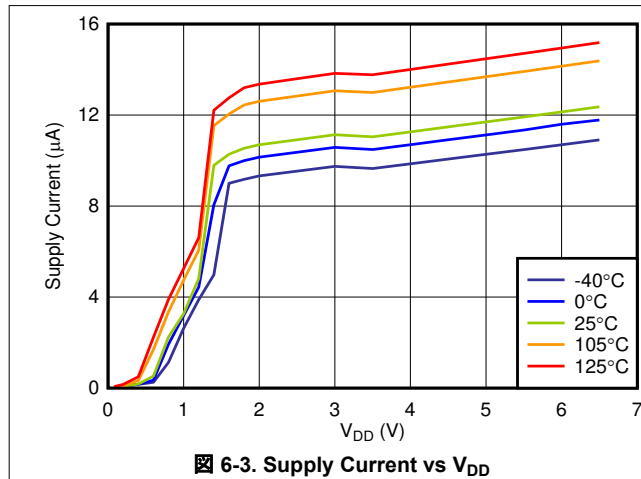



## 6.8 Typical Characteristics (continued)

all typical characteristics curves are taken at 25°C with 1.6 V ≤ VDD ≤ 6.5 V (unless other wise noted)

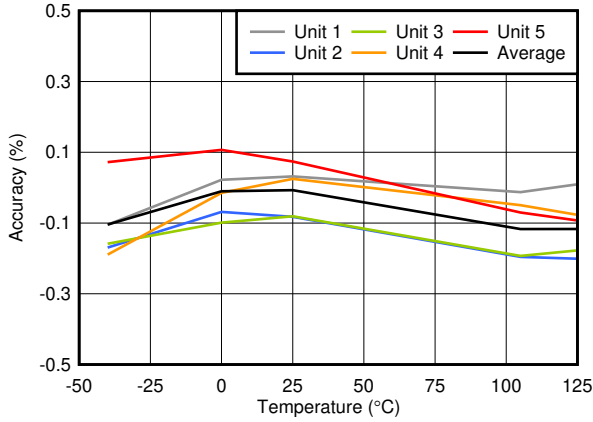

TPS3851G50-Q1,  $V_{ITN} = 4.8\text{ V}$

6-9.  $V_{ITN}$  Accuracy vs Temperature

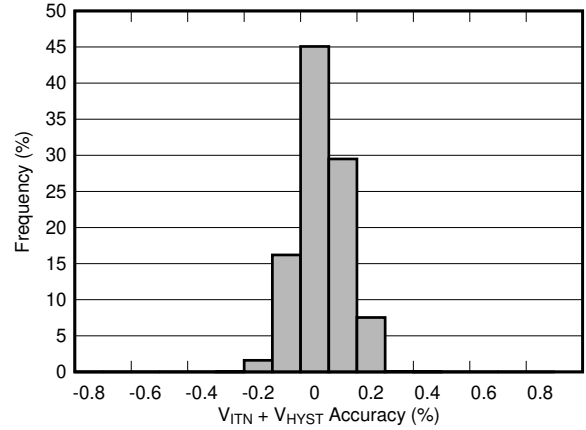

Includes G and H versions; 1.8-V, 2.5-V, 3.0-V, 3.3-V, and 5-V thresholds; total units = 36,627

6-10.  $V_{ITN} + V_{HYST}$  Accuracy Histogram

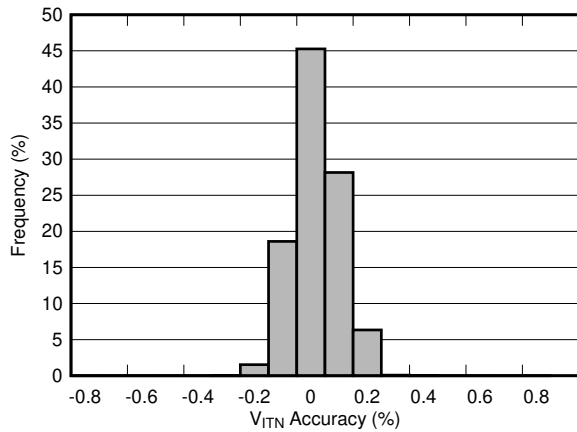

Includes G and H versions; 1.8-V, 2.5-V, 3.0-V, 3.3-V, and 5-V thresholds; total units = 36,627

6-11.  $V_{ITN}$  Accuracy Histogram

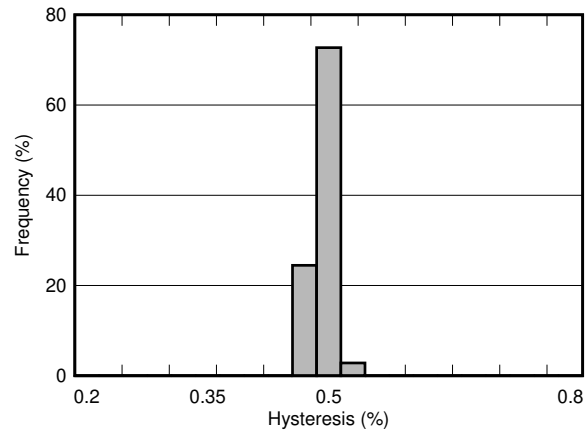

Includes G and H versions; 1.8-V, 2.5-V, 3.0-V, 3.3-V, and 5-V thresholds; total units = 36,627

6-12. Hysteresis Histogram

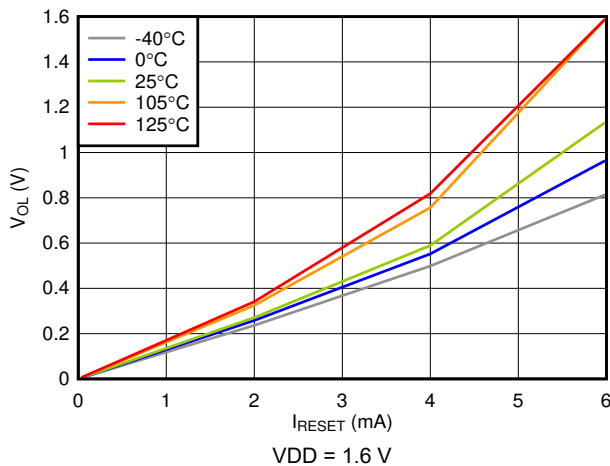

6-13. Low-Level RESET Voltage vs RESET Current

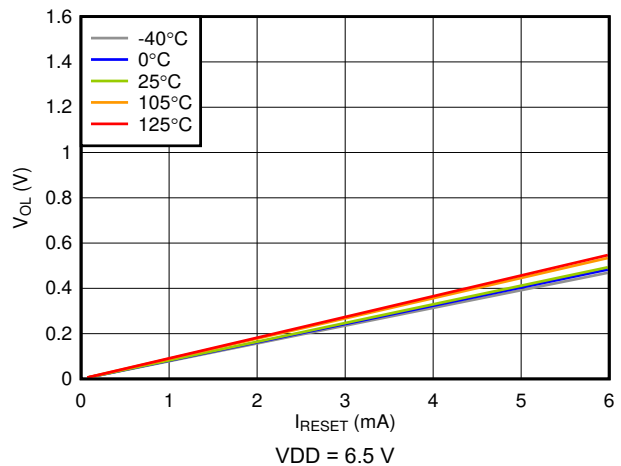

6-14. Low-Level RESET Voltage vs RESET Current

### 6.8 Typical Characteristics (continued)

all typical characteristics curves are taken at 25°C with 1.6 V ≤ VDD ≤ 6.5 V (unless other wise noted)

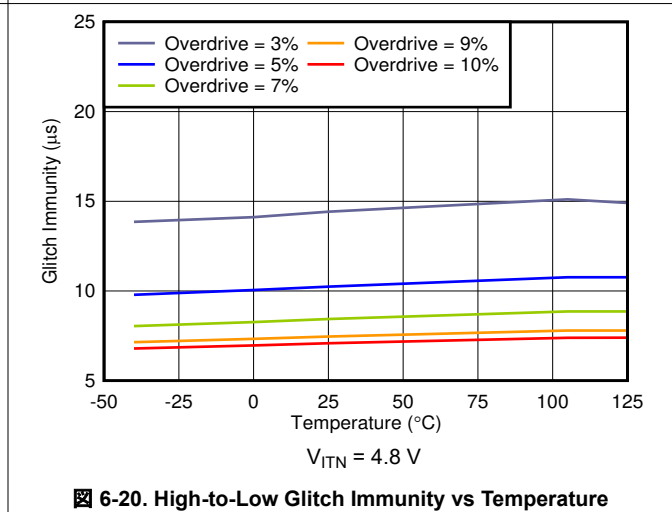
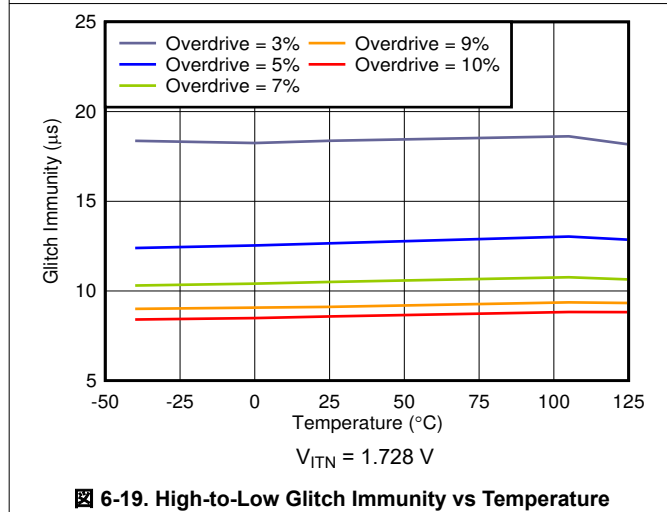
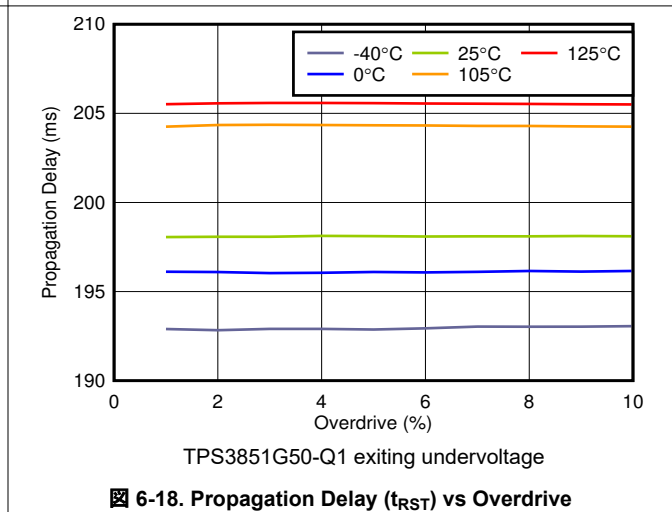
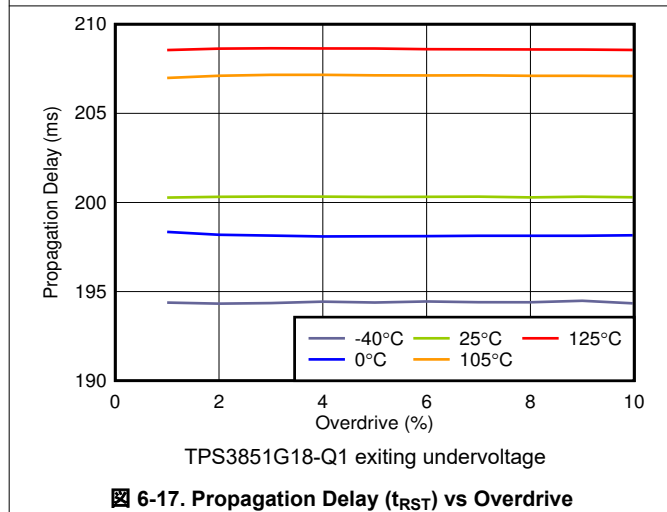
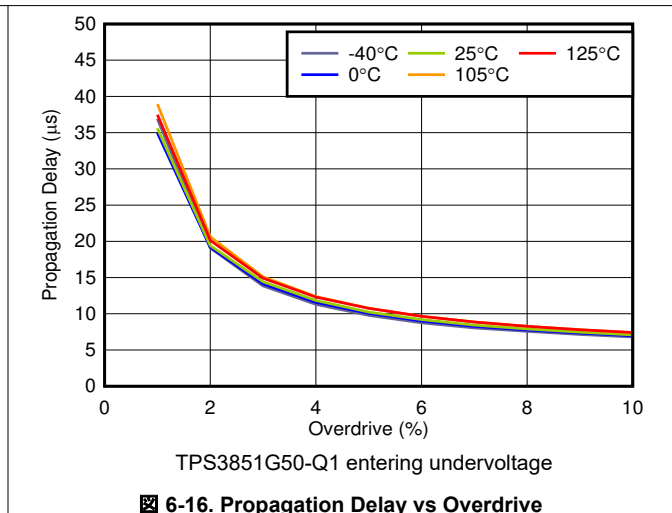
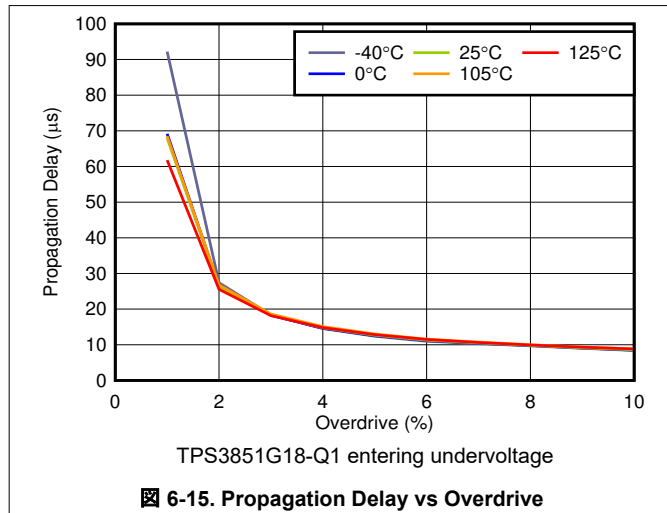

## 7 Detailed Description

### 7.1 Overview

The TPS3851-Q1 is a high-accuracy voltage supervisor with an integrated watchdog timer. This device includes a precision undervoltage supervisor with a threshold that achieves 0.8% accuracy over the specified temperature range of  $-40^{\circ}\text{C}$  to  $+125^{\circ}\text{C}$ . In addition, the TPS3851-Q1 includes accurate hysteresis on the threshold, making the device ideal for use with tight tolerance systems where voltage supervisors must ensure a  $\overline{\text{RESET}}$  before the minimum supply tolerance of the microprocessor or system-on-a-chip (SoC) is reached. There are two options for the watchdog timing standard and extended timing. To get standard timing use the TPS3851Xyy(y)S-Q1, for extended timing use the TPS3851Xyy(y)E-Q1.

### 7.2 Functional Block Diagram

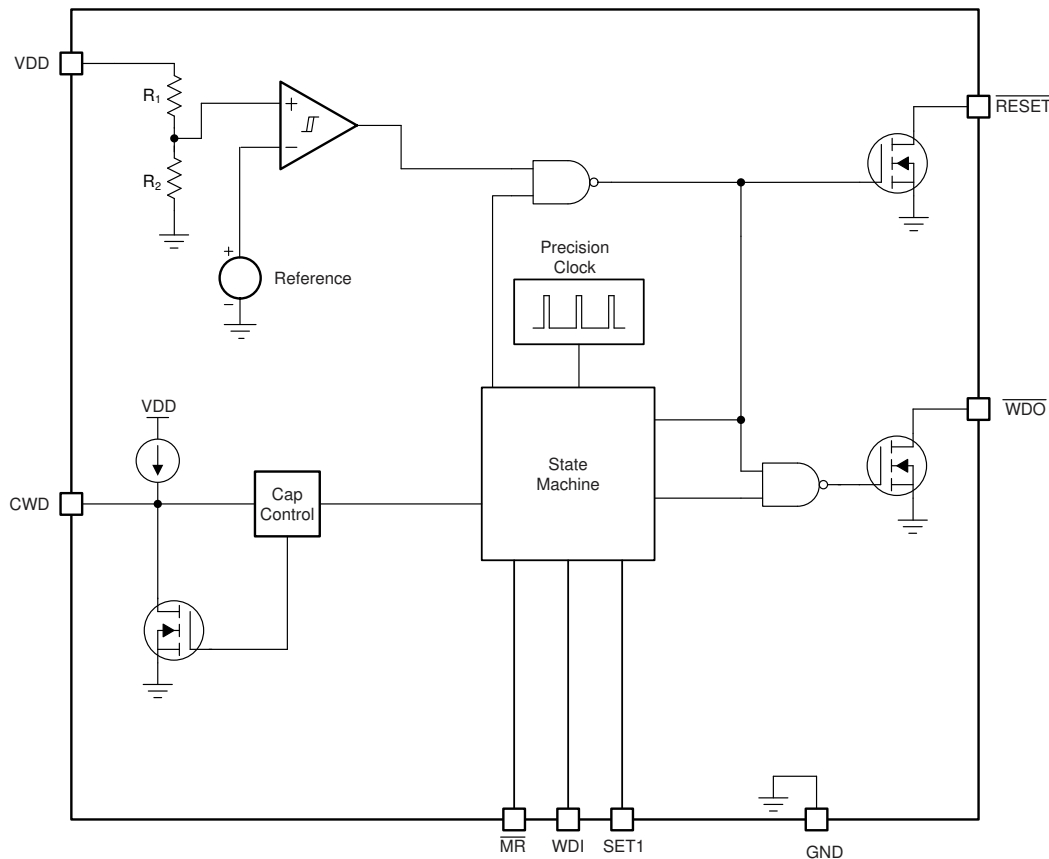

$$R_1 + R_2 = 4.5 \text{ M}\Omega.$$

### 7.3 Feature Description

#### 7.3.1 RESET

Connect  $\overline{\text{RESET}}$  to  $V_{PU}$  through a 1-k $\Omega$  to 100-k $\Omega$  pullup resistor.  $\overline{\text{RESET}}$  remains high (deasserted) when  $V_{DD}$  is greater than the negative threshold voltage ( $V_{ITN}$ ). If  $V_{DD}$  falls below the negative threshold ( $V_{ITN}$ ), then  $\overline{\text{RESET}}$  is asserted, driving the  $\overline{\text{RESET}}$  pin to low impedance. When  $V_{DD}$  rises above  $V_{ITN} + V_{HYST}$ , a delay circuit is enabled that holds  $\overline{\text{RESET}}$  low for a specified reset delay period ( $t_{RST}$ ). When the reset delay has elapsed, the  $\overline{\text{RESET}}$  pin goes to a high-impedance state and uses a pullup resistor to hold  $\overline{\text{RESET}}$  high. The pullup resistor must be connected to the proper voltage rail to allow other devices to be connected at the correct interface voltage. To ensure proper voltage levels, give some consideration when choosing the pullup resistor values. The pullup resistor value is determined by output logic low voltage ( $V_{OL}$ ), capacitive loading, leakage current ( $I_D$ ), and the current through the  $\overline{\text{RESET}}$  pin  $I_{\overline{\text{RESET}}}$ .

### 7.3.2 Manual Reset $\overline{\text{MR}}$

The manual reset ( $\overline{\text{MR}}$ ) input allows a processor or other logic circuits to initiate a reset. A logic low on  $\overline{\text{MR}}$  causes  $\overline{\text{RESET}}$  to assert. After  $\overline{\text{MR}}$  returns to a logic high and  $V_{\text{DD}}$  is above  $V_{\text{ITN}} + V_{\text{HYST}}$ ,  $\overline{\text{RESET}}$  is deasserted after the reset delay time ( $t_{\text{RST}}$ ). If  $\overline{\text{MR}}$  is not controlled externally, then  $\overline{\text{MR}}$  can either be connected to  $V_{\text{DD}}$  or left floating because the  $\overline{\text{MR}}$  pin is internally pulled up.

### 7.3.3 UV Fault Detection

The TPS3851-Q1 features undervoltage detection for common rails between 1.8 V and 5 V. The voltage is monitored on the input rail of the device. If  $V_{\text{DD}}$  drops below  $V_{\text{ITN}}$ , then  $\overline{\text{RESET}}$  is asserted (driven low).

Figure 7-1 shows that when  $V_{\text{DD}}$  is above  $V_{\text{ITN}} + V_{\text{HYST}}$ ,  $\overline{\text{RESET}}$  deasserts after  $t_{\text{RST}}$ . The internal comparator has built-in hysteresis that provides some noise immunity and ensures stable operation. Although not required in most cases, for noisy applications, good analog design practice is to place a 1-nF to 100-nF bypass capacitor close to the  $V_{\text{DD}}$  pin to reduce sensitivity to transient voltages on the monitored signal.

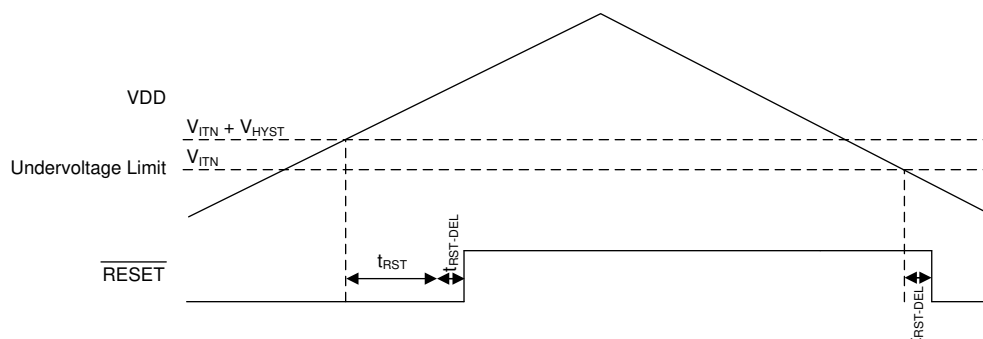

Figure 7-1. Undervoltage Detection

### 7.3.4 Watchdog Mode

This section provides information for the watchdog mode of operation.

#### 7.3.4.1 CWD

The CWD pin provides the user the functionality of both high-precision, factory-programmed watchdog timing options and user-programmable watchdog timing. The TPS3851-Q1 features three options for setting the watchdog timer: connecting a capacitor to the CWD pin, connecting a pullup resistor to  $V_{\text{DD}}$ , and leaving the CWD pin unconnected. The configuration of the CWD pin is evaluated by the device every time  $V_{\text{DD}}$  enters the valid region ( $V_{\text{ITN}} + V_{\text{HYST}} < V_{\text{DD}}$ ). The pin evaluation is controlled by an internal state machine that determines which option is connected to the CWD pin. The sequence of events typically takes 381  $\mu\text{s}$  ( $t_{\text{INIT}}$ ) to determine if the CWD pin is left unconnected, pulled-up through a resistor, or connected to a capacitor. If the CWD pin is being pulled up to  $V_{\text{DD}}$ , a 10-k $\Omega$  resistor is required.

#### 7.3.4.2 Watchdog Input WDI

WDI is the watchdog timer input that controls the  $\overline{\text{WDO}}$  output. The WDI input is triggered by the falling edge of the input signal. To ensure proper functionality of the watchdog timer, always issue the WDI pulse before  $t_{\text{WD(min)}}$ . If the pulse is issued in this region, then  $\overline{\text{WDO}}$  remains unasserted. Otherwise, the device asserts  $\overline{\text{WDO}}$ , putting the  $\overline{\text{WDO}}$  pin into a low-impedance state.

The watchdog input (WDI) is a digital pin. In order to ensure there is no increase in  $I_{\text{DD}}$ , drive the WDI pin to either  $V_{\text{DD}}$  or GND at all times. Putting the pin to an intermediate voltage can cause an increase in supply current ( $I_{\text{DD}}$ ) because of the architecture of the digital logic gates. When  $\overline{\text{RESET}}$  is asserted, the watchdog is disabled and all signals input to WDI are ignored. When  $\overline{\text{RESET}}$  is no longer asserted, the device resumes normal operation and no longer ignores the signal on WDI. If the watchdog is disabled, drive the WDI pin to either  $V_{\text{DD}}$  or GND. Figure 7-2 shows the valid region for a WDI pulse to be issued to prevent  $\overline{\text{WDO}}$  from being triggered and pulled low.

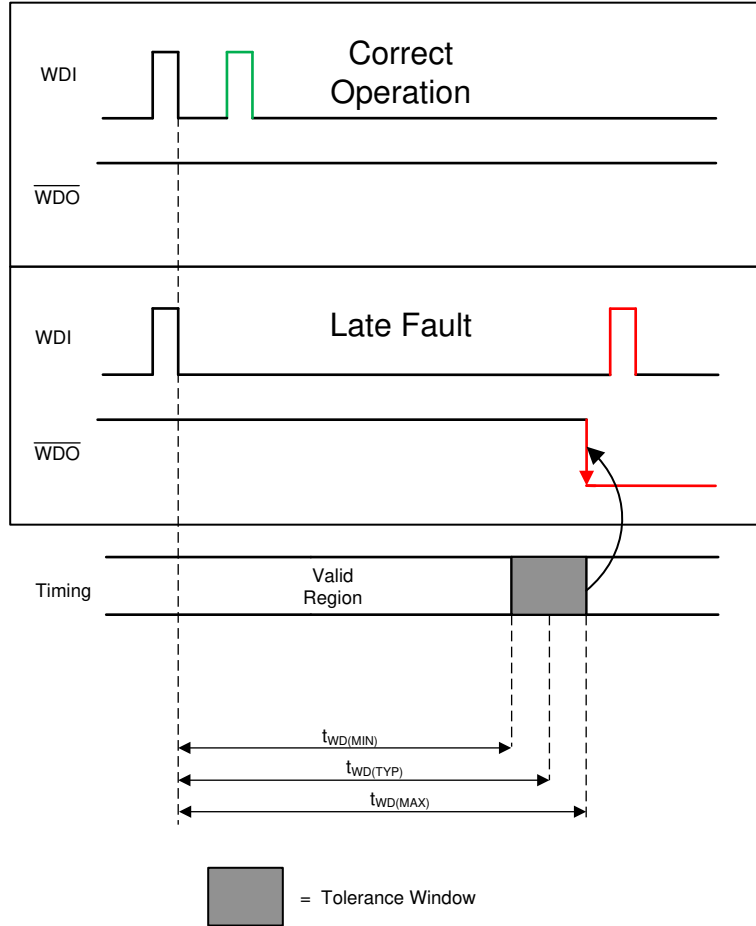

7-2. Watchdog Timing Diagram

### 7.3.4.3 Watchdog Output $\overline{WDO}$

The TPS3851-Q1 features a watchdog timer with an independent watchdog output ( $\overline{WDO}$ ). The independent watchdog output provides the flexibility to flag a fault in the watchdog timing without performing an entire system reset. When  $\overline{RESET}$  is not asserted (high), the  $\overline{WDO}$  signal maintains normal operation. When asserted,  $\overline{WDO}$  remains low for  $t_{RST}$ . When the  $\overline{RESET}$  signal is asserted (low), the  $\overline{WDO}$  pin goes to a high-impedance state. When  $\overline{RESET}$  is unasserted, the watchdog timer resumes normal operation.

### 7.3.4.4 SET1

The SET1 pin can enable and disable the watchdog timer. If SET1 is set to GND, the watchdog timer is disabled and WDI is ignored. If the watchdog timer is disabled, drive the WDI pin to either GND or VDD to ensure that there is no increase in  $I_{DD}$ . When SET1 is logic high, the watchdog operates normally. The SET1 pin can be changed dynamically; however, if the watchdog is going from disabled to enabled (as shown in [Figure 7-3](#)) there is a 150- $\mu$ s setup time where the watchdog does not respond to changes on WDI.



图 7-3. Enabling and Disabling the Watchdog

## 7.4 Device Functional Modes

表 7-1 summarises the functional modes of the TPS3851-Q1.

表 7-1. Device Functional Modes

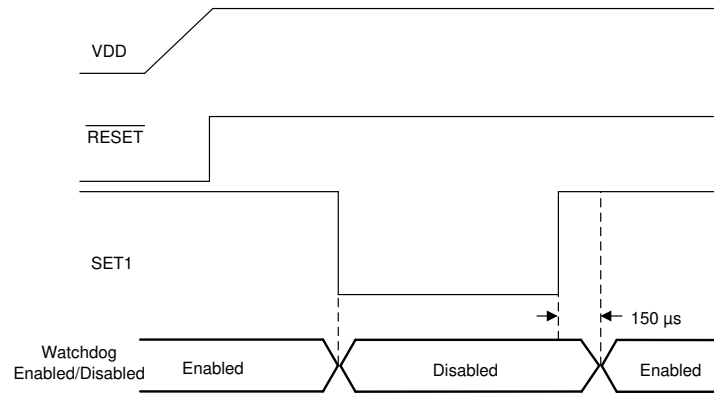
$V_{DD}$	WDI	$\overline{WDO}$	RESET
$V_{DD} < V_{POR}$	—	—	Undefined
$V_{POR} \leq V_{DD} < V_{DD(min)}$	Ignored	High	Low
$V_{DD(min)} \leq V_{DD} \leq V_{ITN} + V_{HYST}$ <sup>(1)</sup>	Ignored	High	Low
$V_{DD} > V_{ITN}$ <sup>(2)</sup>	$t_{PULSE} < t_{WD(min)}$ <sup>(3)</sup>	High	High
$V_{DD} > V_{ITN}$ <sup>(2)</sup>	$t_{PULSE} > t_{WD(min)}$ <sup>(3)</sup>	Low	High

(1) Only valid before  $V_{DD}$  has gone above  $V_{ITN} + V_{HYST}$ .

(2) Only valid after  $V_{DD}$  has gone above  $V_{ITN} + V_{HYST}$ .

(3) Where  $t_{pulse}$  is the time between the falling edges on WDI.

### 7.4.1 $V_{DD}$ is Below $V_{POR}$ ( $V_{DD} < V_{POR}$ )

When  $V_{DD}$  is less than  $V_{POR}$ ,  $\overline{RESET}$  is undefined and can be either high or low. The state of  $\overline{RESET}$  largely depends on the load that the  $\overline{RESET}$  pin is experiencing.

### 7.4.2 Above Power-On-Reset, But Less Than $V_{DD(min)}$ ( $V_{POR} \leq V_{DD} < V_{DD(min)}$ )

When the voltage on  $V_{DD}$  is less than  $V_{DD(min)}$ , and greater than or equal to  $V_{POR}$ , the  $\overline{RESET}$  signal is asserted (logic low). When  $\overline{RESET}$  is asserted, the watchdog output  $\overline{WDO}$  is in a high-impedance state regardless of the WDI signal that is input to the device.

### 7.4.3 Normal Operation ( $V_{DD} \geq V_{DD(min)}$ )

When  $V_{DD}$  is greater than or equal to  $V_{DD(min)}$ , the  $\overline{RESET}$  signal is determined by  $V_{DD}$ . When  $\overline{RESET}$  is asserted,  $\overline{WDO}$  goes to a high-impedance state.  $\overline{WDO}$  is then pulled high through the pullup resistor.

## 8 Application and Implementation

### Note

以下のアプリケーション情報は、TI の製品仕様に含まれるものではなく、TI ではその正確性または完全性を保証いたしません。個々の目的に対する製品の適合性については、お客様の責任で判断していただくことになります。お客様は自身の設計実装を検証しテストすることで、システムの機能を確認する必要があります。

### 8.1 Application Information

The following sections describe in detail proper device implementation, depending on the final application requirements.

#### 8.1.1 CWD Functionality

The TPS3851-Q1 features three options for setting the watchdog timer: connecting a capacitor to the CWD pin, connecting a pullup resistor to VDD, and leaving the CWD pin unconnected. [図 8-1](#) shows a schematic drawing of all three options. If this pin is connected to VDD through a 10-k $\Omega$  pullup resistor or left unconnected (high impedance), then the factory-programmed watchdog timeouts are enabled; see the [セクション 8.1.1.1](#) section. Otherwise, the watchdog timeout can be adjusted by placing a capacitor from the CWD pin to ground.



図 8-1. CWD Charging Circuit

#### 8.1.1.1 Factory-Programmed Timing Options

If using the factory-programmed timing options (listed in [表 8-1](#)), the CWD pin must either be unconnected or pulled up to VDD through a 10-k $\Omega$  pullup resistor. Using these options enables high-precision, 15% accurate watchdog timing.

表 8-1. Factory Programmed Watchdog Timing

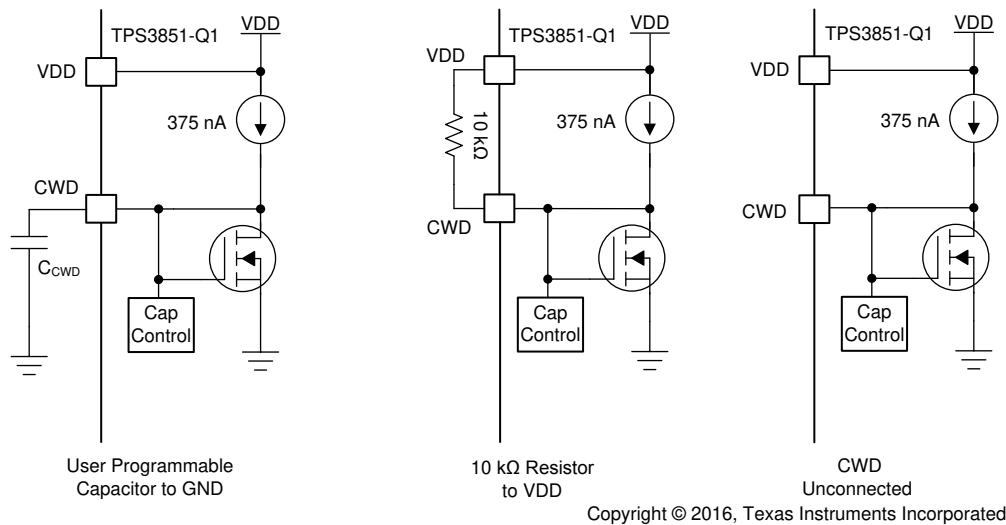
INPUT		STANDARD AND EXTENDED TIMING WDT ( $t_{WD}$ )			UNIT
CWD	SET1	MIN	TYP	MAX	
NC	0	Watchdog disabled			
NC	1	1360	1600	1840	ms
10 k $\Omega$ to VDD	0	Watchdog disabled			
10 k $\Omega$ to VDD	1	170	200	230	ms

### 8.1.1.2 Adjustable Capacitor Timing

Adjustable capacitor timing is achievable by connecting a capacitor to the CWD pin. If a capacitor is connected to CWD, then a 375-nA, constant-current source charges  $C_{CWD}$  until  $V_{CWD} = 1.21$  V. 表 8-2 shows how to calculate  $t_{WD}$  using 式 1, 式 2, and the SET1 pin. The TPS3851-Q1 determines the watchdog timeout with the formulas given in 式 1 and 式 2, where  $C_{CWD}$  is in nanofarads and  $t_{WD}$  is in milliseconds.

$$t_{WD(\text{standard})} (\text{ms}) = 3.23 \times C_{CWD} (\text{nF}) + 0.381 (\text{ms}) \quad (1)$$

$$t_{WD(\text{extended})} (\text{ms}) = 77.4 \times C_{CWD} (\text{nF}) + 55 (\text{ms}) \quad (2)$$

The TPS3851-Q1 is designed and tested using  $C_{CWD}$  capacitors between 100 pF and 1  $\mu\text{F}$ . 式 1 and 式 2 are for ideal capacitors; capacitor tolerances vary the actual device timing. For the most accurate timing, use ceramic capacitors with COG dielectric material. If a  $C_{CWD}$  capacitor is used, 式 1 can be used to set  $t_{WD}$  for standard timing. Use 式 2 to calculate  $t_{WD}$  for extended timing. 表 8-3 shows the minimum and maximum calculated  $t_{WD}$  values using an ideal capacitor for both standard and extended timing.

表 8-2. Programmable CWD Timing

INPUT		STANDARD TIMING WDT ( $t_{WD}$ )			EXTENDED TIMING WDT ( $t_{WD}$ )			UNIT
CWD	SET1	MIN	TYP	MAX	MIN	TYP	MAX	
$C_{CWD}$	0	Watchdog disabled			Watchdog disabled			
$C_{CWD}$	1	$t_{WD(\text{std})} \times 0.905$	$t_{WD(\text{std})}^{(1)}$	$t_{WD(\text{std})} \times 1.095$	$t_{WD(\text{ext})} \times 0.905$	$t_{WD(\text{ext})}^{(2)}$	$t_{WD(\text{ext})} \times 1.095$	ms

(1) Calculated from 式 1 using an ideal capacitor.

(2) Calculated from 式 2 using an ideal capacitor.

表 8-3.  $t_{WD}$  Values for Common Ideal Capacitor Values

$C_{CWD}$	STANDARD TIMING WDT ( $t_{WD}$ )			EXTENDED TIMING WDT ( $t_{WD}$ )			UNIT
	MIN <sup>(1)</sup>	TYP	MAX <sup>(1)</sup>	MIN <sup>(1)</sup>	TYP	MAX <sup>(1)</sup>	
100 pF	0.637	0.704	0.771	56.77	62.74	68.7	ms
1 nF	3.268	3.611	3.954	119.82	132.4	144.98	ms
10 nF	29.58	32.68	35.79	750	829	908	ms
100 nF	292.7	323.4	354.1	7054	7795	8536	ms
1 $\mu\text{F}$	2923	3230	3537	70096	77455	84814	ms

(1) The minimum and maximum values are calculated using an ideal capacitor.



### 8.1.2 Overdrive Voltage

Forcing a  $\overline{\text{RESET}}$  is dependent on two conditions: the amplitude  $V_{DD}$  is beyond the trip point ( $\Delta V_1$  and  $\Delta V_2$ ), and the length of time that the voltage is beyond the trip point ( $t_1$  and  $t_2$ ). If the voltage is just under the trip point for a long period of time,  $\overline{\text{RESET}}$  asserts and the output is pulled low. However, if  $V_{DD}$  is just under the trip point for a few nanoseconds,  $\overline{\text{RESET}}$  does not assert and the output remains high. The length of time required for  $\overline{\text{RESET}}$  to assert can be changed by increasing the amount  $V_{DD}$  goes under the trip point. If  $V_{DD}$  is under the trip point by 10%, the amount of time required for the comparator to respond is much faster and causes  $\overline{\text{RESET}}$  to assert much quicker than when barely under the trip point voltage. 式 3 shows how to calculate the percentage overdrive.

$$\text{Overdrive} = |(V_{DD} / V_{ITX}) - 1| \times 100\% \quad (3)$$

In 式 3,  $V_{ITX}$  corresponds to the threshold trip point. If  $V_{DD}$  is exceeding the positive threshold,  $V_{ITN} + V_{HYST}$  is used.  $V_{ITN}$  is used when  $V_{DD}$  is falling below the negative threshold. In 图 8-2,  $t_1$  and  $t_2$  correspond to the amount of time that  $V_{DD}$  is over the threshold; the propagation delay versus overdrive for  $V_{ITN}$  and  $V_{ITN} + V_{HYST}$  is illustrated in 图 6-16 and 图 6-18, respectively.

The TPS3851-Q1 is relatively immune to short positive and negative transients on  $V_{DD}$  because of the overdrive voltage curve.



图 8-2. Overdrive Voltage

## 8.2 Typical Application

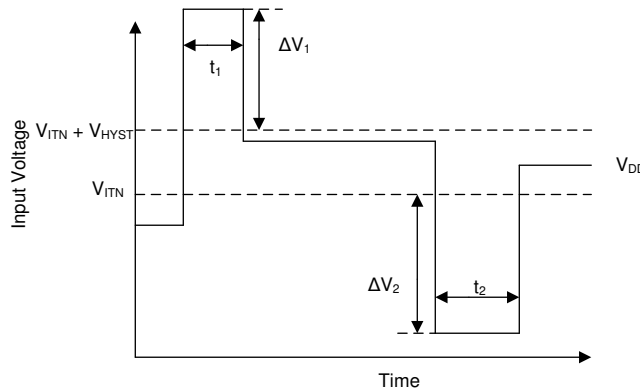
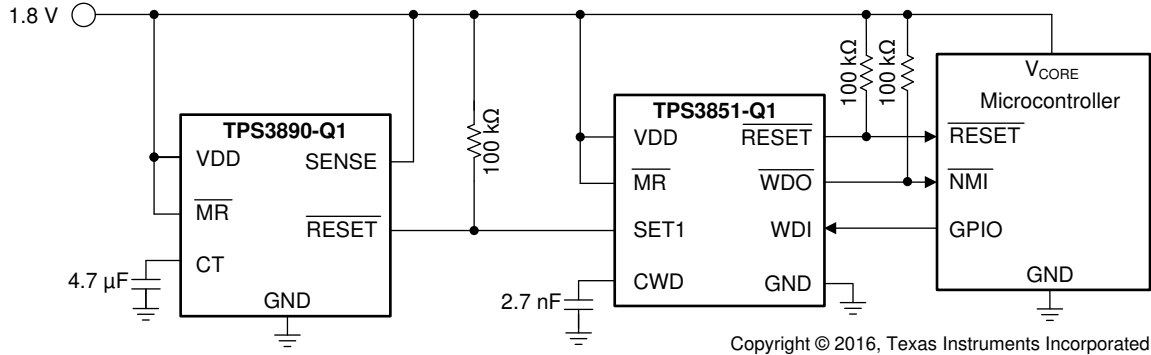

**8-3. Monitoring the Supply Voltage and Watchdog Supervision of a Microcontroller**

### 8.2.1 Design Requirements

PARAMETER	DESIGN REQUIREMENT	DESIGN RESULT
Watchdog disable for initialization period	Watchdog must remain disabled for 5 seconds until logic enables the watchdog timer	5.02 seconds (typ)
Output logic voltage	1.8-V CMOS	1.8-V CMOS
Monitored rail	1.8 V with a 5% threshold	Worst-case $V_{ITN} = 1.714 \text{ V} - 4.7\%$
Watchdog timeout	10 ms, typical	$t_{WD(min)} = 7.3 \text{ ms}$ , $t_{WD(TYP)} = 9.1 \text{ ms}$ , $t_{WD(max)} = 11 \text{ ms}$
Maximum device current consumption	50 $\mu\text{A}$	37 $\mu\text{A}$ when $\overline{\text{RESET}}$ or $\overline{\text{WDO}}$ is asserted <sup>(1)</sup>

(1) Only includes the TPS3851G18S-Q1 current consumption.

### 8.2.2 Detailed Design Procedure

#### 8.2.2.1 Monitoring the 1.8-V Rail

The undervoltage comparator allows for precise voltage supervision of common rails between 1.8 V and 5.0 V. This application calls for very tight monitoring of the rail with only 5% of variation allowed on the rail. To ensure this requirement is met, the TPS3851G18S-Q1 was chosen for its  $-4\%$  threshold. To calculate the worst-case for  $V_{ITN}$ , the accuracy must also be taken into account. The worst-case for  $V_{ITN}$  can be calculated by [式 4](#):

$$V_{ITN(\text{Worst Case})} = V_{ITN(\text{typ})} \times 0.992 = 1.8 \times 0.96 \times 0.992 = 1.714 \text{ V} \quad (4)$$

### 8.2.2.2 Calculating the $\overline{\text{RESET}}$ and $\overline{\text{WDO}}$ Pullup Resistor

Figure 8-4 shows the TPS3851-Q1 using an open-drain configuration for the  $\overline{\text{RESET}}$  circuit. When the FET is off, the resistor pulls the drain of the transistor to VDD and when the FET is turned on, the FET attempts to pull the drain to ground, thus creating an effective resistor divider. The resistors in this divider must be chosen to ensure that  $V_{OL}$  is below the maximum value. To choose the proper pullup resistor, there are three key specifications to keep in mind: the pullup voltage ( $V_{PU}$ ), the recommended maximum  $\overline{\text{RESET}}$  pin current ( $I_{\overline{\text{RESET}}}$ ), and  $V_{OL}$ . The maximum  $V_{OL}$  is 0.4 V, meaning that the effective resistor divider created must be able to bring the voltage on the reset pin below 0.4 V with  $I_{\overline{\text{RESET}}}$  kept below 10 mA. For this example, with a  $V_{PU}$  of 1.8 V, a resistor must be chosen to keep  $I_{\overline{\text{RESET}}}$  below 50  $\mu\text{A}$  because this value is the maximum consumption current allowed. To ensure this specification is met, a pullup resistor value of 100 k $\Omega$  was selected, which sinks a maximum of 18  $\mu\text{A}$  when  $\overline{\text{RESET}}$  or  $\overline{\text{WDO}}$  is asserted. As illustrated in Figure 6-13, the  $\overline{\text{RESET}}$  current is at 18  $\mu\text{A}$  and the low-level output voltage is approximately zero.

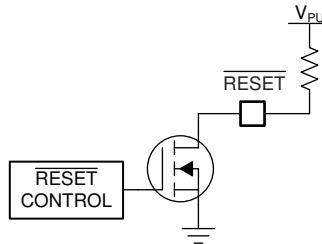

Figure 8-4.  $\overline{\text{RESET}}$  Open-Drain Configuration

### 8.2.2.3 Setting the Watchdog

As illustrated in Figure 8-1 there are three options for setting the watchdog timer. The design specifications in this application require the programmable timing option (external capacitor connected to CWD). When a capacitor is connected to the CWD pin, the watchdog timer is governed by Equation 1 for the standard timing version. However, only the standard version is capable of meeting this timing requirement. Equation 1 is only valid for ideal capacitors, any temperature or voltage derating must be accounted for separately.

$$C_{\text{CWD}} \text{ (nF)} = (t_{\text{WD}} \text{ (ms)} - 0.0381) / 3.23 = (10 - 0.381) / 3.23 = 2.97 \text{ nF} \quad (5)$$

The nearest standard capacitor value to 2.9 nF is 2.7 nF. Selecting 2.7 nF for the  $C_{\text{CWD}}$  capacitor gives the following minimum timing parameters:

$$t_{\text{WD(MIN)}} = 0.905 \times t_{\text{WD(TYP)}} = 0.905 \times (3.23 \times 2.7 + 0.381) = 8.24 \text{ ms} \quad (6)$$

$$t_{\text{WD(MAX)}} = 1.095 \times t_{\text{WD(TYP)}} = 1.095 \times (3.23 \times 2.7 + 0.381) = 9.97 \text{ ms} \quad (7)$$

Capacitor tolerance also influences  $t_{\text{WD(MIN)}}$  and  $t_{\text{WD(MAX)}}$ . Select a ceramic COG dielectric capacitor for high accuracy. For 2.7 nF, COG capacitors are readily available with 5% tolerances. This selection results in a 5% decrease in  $t_{\text{WD(MIN)}}$  and a 5% increase in  $t_{\text{WD(MAX)}}$ , giving 7.34 ms and 11 ms, respectively. To ensure proper functionality, a falling edge must be issued before  $t_{\text{WD(min)}}$ . Figure 8-6 illustrates that a WDI signal with a period of 5 ms keeps WDO from asserting.

### 8.2.2.4 Watchdog Disabled During Initialization Period

The watchdog is often needed to be disabled during startup to allow for an initialization period. When the initialization period is over, the watchdog timer is turned back on to allow the microcontroller to be monitored by the TPS3851-Q1. To achieve this setup, SET1 must start at GND. In this design, SET1 is controlled by a [TPS3890-Q1](#) supervisor. In this application, the TPS3890-Q1 was chosen to monitor V<sub>DD</sub> as well, which means that the  $\overline{\text{RESET}}$  on the TPS3890-Q1 stays low until V<sub>DD</sub> rises above V<sub>ITN</sub>. When V<sub>DD</sub> comes up, the delay time can be adjusted through the CT capacitor on the TPS3890-Q1. With this approach, the  $\overline{\text{RESET}}$  delay can be adjusted from a minimum of 25  $\mu\text{s}$  to a maximum of 30 seconds. For this design, a typical delay of 5 seconds is needed before the watchdog timer is enabled. The CT capacitor calculation (see the [TPS3890-Q1 data sheet](#)) yields an ideal capacitance of 4.67  $\mu\text{F}$ , giving a closest standard ceramic capacitor value of 4.7  $\mu\text{F}$ . When connecting a 4.7- $\mu\text{F}$  capacitor from CT to GND, the typical delay time is 5 seconds. [Figure 8-5](#) shows that when the watchdog is disabled, the  $\overline{\text{WDO}}$  output remains high. However when SET1 goes high and there is no WDI signal,  $\overline{\text{WDO}}$  begins to assert. See the [TPS3890-Q1 data sheet](#) for detailed information on the TPS3890-Q1.

### 8.2.3 Glitch Immunity

[Figure 8-8](#) shows the high-to-low glitch immunity for the TPS3851G18S-Q1 with a 7% overdrive with V<sub>DD</sub> starting at 1.8 V. This curve shows that V<sub>DD</sub> can go below the threshold for at least 6  $\mu\text{s}$  before  $\overline{\text{RESET}}$  asserts.

### 8.2.4 Application Curves

Unless otherwise stated, application curves were taken at T<sub>A</sub> = 25°C.

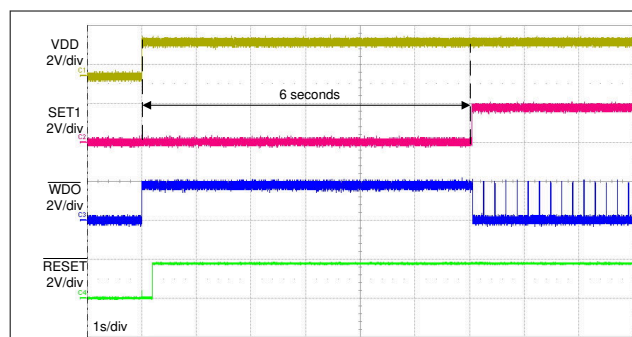

**Figure 8-5. Startup Without a WDI Signal**

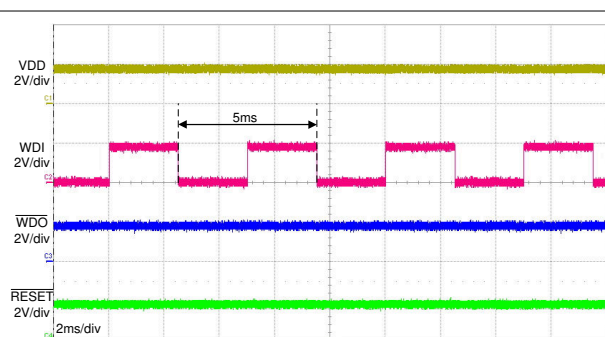

**Figure 8-6. Typical WDI Signal**

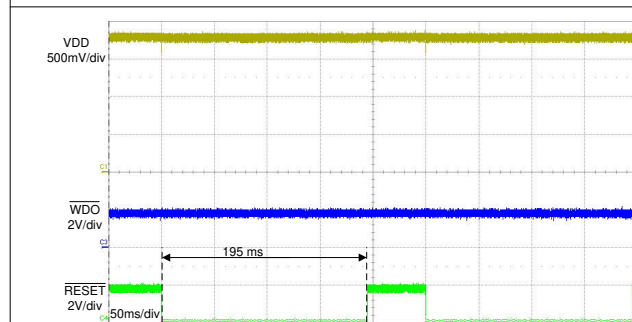

**Figure 8-7. Typical  $\overline{\text{RESET}}$  Delay**

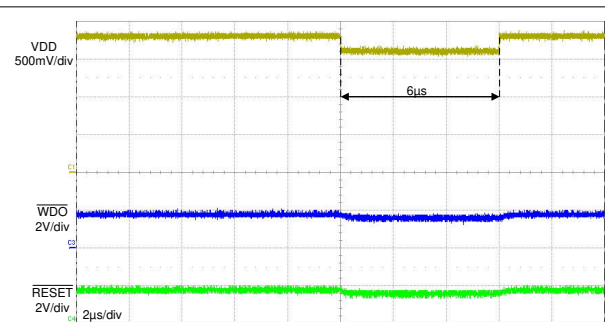

**Figure 8-8. High-to-Low Glitch Immunity**

## 9 Power Supply Recommendations

This device is designed to operate from an input supply with a voltage range between 1.6 V and 6.5 V. An input supply capacitor is not required for this device; however, if the input supply is noisy, then good analog practice is to place a 0.1- $\mu$ F capacitor between the VDD pin and the GND pin.

## 10 Layout

### 10.1 Layout Guidelines

- Make sure that the connection to the VDD pin is low impedance. Good analog design practice is to place a 0.1- $\mu$ F ceramic capacitor as near as possible to the VDD pin.
- If a  $C_{CWD}$  capacitor or pullup resistor is used, place these components as close as possible to the CWD pin. If the CWD pin is left unconnected, make sure to minimize the amount of parasitic capacitance on the pin.
- Place the pullup resistors on RESET and WDO as close to the pin as possible.

### 10.2 Layout Example

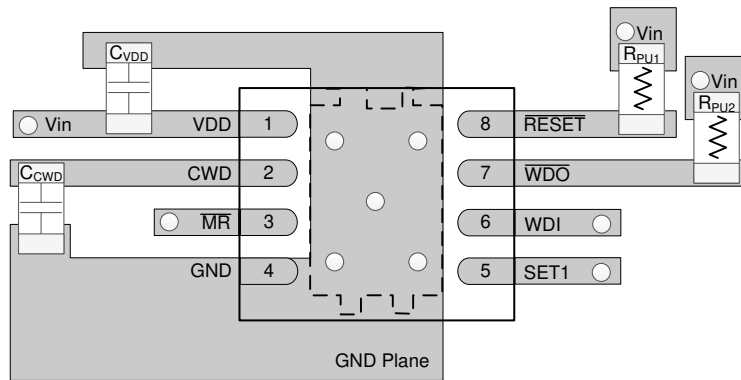

○ Denotes a via

**10-1. TPS3851-Q1 Recommended Layout**

## 11 Device and Documentation Support

### 11.1 Device Support

#### 11.1.1 Device Nomenclature

表 11-1. Device Nomenclature

DESCRIPTION	NOMENCLATURE	VALUE
TPS3851-Q1 (high-accuracy supervisor with watchdog)	—	—
X (nominal threshold as a percent of the nominal monitored voltage)	G	$V_{ITN} = -4\%$
	H	$V_{ITN} = -7\%$
yy(y) (nominal monitored voltage option)	18	1.8 V
	25	2.5 V
	30	3.0 V
	33	3.3 V
	50	5.0 V
z (nominal watchdog timeout period)	S	$t_{WD} \text{ (ms)} = 3.23 \times C_{WD} \text{ (nF)} + 0.381 \text{ (ms)}$
	E	$t_{WD} \text{ (ms)} = 77.4 \times C_{WD} \text{ (nF)} + 55.2 \text{ (ms)}$

### 11.2 Documentation Support

#### 11.2.1 Related Documentation

For related documentation see the following:

- [TPS3890-Q1 Low Quiescent Current, 1% Accurate Supervisor with Programmable Delay](#)
- [TPS3851EVM-780 Evaluation Module](#)

#### 11.3 Receiving Notification of Documentation Updates

To receive notification of documentation updates, navigate to the device product folder on [ti.com](http://ti.com). Click on *Subscribe to updates* to register and receive a weekly digest of any product information that has changed. For change details, review the revision history included in any revised document.

#### 11.4 サポート・リソース

TI E2E™ サポート・フォーラムは、エンジニアが検証済みの回答と設計に関するヒントをエキスパートから迅速かつ直接得ることができる場所です。既存の回答を検索したり、独自の質問をしたりすることで、設計に必要な支援を迅速に得ることができます。

リンクされているコンテンツは、該当する貢献者により、現状のまま提供されるものです。これらは TI の仕様を構成するものではなく、必ずしも TI の見解を反映したものではありません。TI の [使用条件](#) を参照してください。

#### 11.5 Trademarks

TI E2E™ is a trademark of Texas Instruments.

すべての商標は、それぞれの所有者に帰属します。

#### 11.6 Electrostatic Discharge Caution



This integrated circuit can be damaged by ESD. Texas Instruments recommends that all integrated circuits be handled with appropriate precautions. Failure to observe proper handling and installation procedures can cause damage.

ESD damage can range from subtle performance degradation to complete device failure. Precision integrated circuits may be more susceptible to damage because very small parametric changes could cause the device not to meet its published specifications.

#### 11.7 Glossary

[TI Glossary](#) This glossary lists and explains terms, acronyms, and definitions.

## 12 Mechanical, Packaging, and Orderable Information

The following pages include mechanical, packaging, and orderable information. This information is the most current data available for the designated devices. This data is subject to change without notice and revision of this document. For browser-based versions of this data sheet, refer to the left-hand navigation.



**PACKAGING INFORMATION**

Orderable Device	Status (1)	Package Type	Package Drawing	Pins	Package Qty	Eco Plan (2)	Lead finish/ Ball material (6)	MSL Peak Temp (3)	Op Temp (°C)	Device Marking (4/5)	Samples
TPS3851G18EQDRBRQ1	ACTIVE	SON	DRB	8	3000	RoHS & Green	NIPDAU   SN	Level-2-260C-1 YEAR	-40 to 125	851DF	<a href="#">Samples</a>
TPS3851G18SQDRBRQ1	ACTIVE	SON	DRB	8	3000	RoHS & Green	NIPDAU   SN	Level-2-260C-1 YEAR	-40 to 125	851DE	<a href="#">Samples</a>
TPS3851G25EQDRBRQ1	ACTIVE	SON	DRB	8	3000	RoHS & Green	NIPDAU   SN	Level-2-260C-1 YEAR	-40 to 125	851EF	<a href="#">Samples</a>
TPS3851G25SQDRBRQ1	ACTIVE	SON	DRB	8	3000	RoHS & Green	NIPDAU   SN	Level-2-260C-1 YEAR	-40 to 125	851EE	<a href="#">Samples</a>
TPS3851G30EQDRBRQ1	ACTIVE	SON	DRB	8	3000	RoHS & Green	NIPDAU   SN	Level-2-260C-1 YEAR	-40 to 125	851FF	<a href="#">Samples</a>
TPS3851G30SQDRBRQ1	ACTIVE	SON	DRB	8	3000	RoHS & Green	NIPDAU   SN	Level-2-260C-1 YEAR	-40 to 125	851FE	<a href="#">Samples</a>
TPS3851G33EQDRBRQ1	ACTIVE	SON	DRB	8	3000	RoHS & Green	NIPDAU   SN	Level-2-260C-1 YEAR	-40 to 125	851GF	<a href="#">Samples</a>
TPS3851G33SQDRBRQ1	ACTIVE	SON	DRB	8	3000	RoHS & Green	NIPDAU   SN	Level-2-260C-1 YEAR	-40 to 125	851GE	<a href="#">Samples</a>
TPS3851G50EQDRBRQ1	ACTIVE	SON	DRB	8	3000	RoHS & Green	NIPDAU   SN	Level-2-260C-1 YEAR	-40 to 125	851HF	<a href="#">Samples</a>
TPS3851G50SQDRBRQ1	ACTIVE	SON	DRB	8	3000	RoHS & Green	NIPDAU   SN	Level-2-260C-1 YEAR	-40 to 125	851HE	<a href="#">Samples</a>
TPS3851H18EQDRBRQ1	ACTIVE	SON	DRB	8	3000	RoHS & Green	NIPDAU   SN	Level-2-260C-1 YEAR	-40 to 125	851LF	<a href="#">Samples</a>
TPS3851H18SQDRBRQ1	ACTIVE	SON	DRB	8	3000	RoHS & Green	NIPDAU   SN	Level-2-260C-1 YEAR	-40 to 125	851LE	<a href="#">Samples</a>
TPS3851H25EQDRBRQ1	ACTIVE	SON	DRB	8	3000	RoHS & Green	NIPDAU   SN	Level-2-260C-1 YEAR	-40 to 125	851MF	<a href="#">Samples</a>
TPS3851H25SQDRBRQ1	ACTIVE	SON	DRB	8	3000	RoHS & Green	NIPDAU   SN	Level-2-260C-1 YEAR	-40 to 125	851ME	<a href="#">Samples</a>
TPS3851H30EQDRBRQ1	ACTIVE	SON	DRB	8	3000	RoHS & Green	NIPDAU   SN	Level-2-260C-1 YEAR	-40 to 125	851NF	<a href="#">Samples</a>
TPS3851H30SQDRBRQ1	ACTIVE	SON	DRB	8	3000	RoHS & Green	NIPDAU   SN	Level-2-260C-1 YEAR	-40 to 125	851NE	<a href="#">Samples</a>
TPS3851H33EQDRBRQ1	ACTIVE	SON	DRB	8	3000	RoHS & Green	NIPDAU   SN	Level-2-260C-1 YEAR	-40 to 125	851PF	<a href="#">Samples</a>
TPS3851H33SQDRBRQ1	ACTIVE	SON	DRB	8	3000	RoHS & Green	NIPDAU   SN	Level-2-260C-1 YEAR	-40 to 125	851PE	<a href="#">Samples</a>
TPS3851H50EQDRBRQ1	ACTIVE	SON	DRB	8	3000	RoHS & Green	NIPDAU   SN	Level-2-260C-1 YEAR	-40 to 125	851RF	<a href="#">Samples</a>
TPS3851H50SQDRBRQ1	ACTIVE	SON	DRB	8	3000	RoHS & Green	NIPDAU   SN	Level-2-260C-1 YEAR	-40 to 125	851RE	<a href="#">Samples</a>

(1) The marketing status values are defined as follows:

**ACTIVE:** Product device recommended for new designs.

**LIFEBUY:** TI has announced that the device will be discontinued, and a lifetime-buy period is in effect.

**NRND:** Not recommended for new designs. Device is in production to support existing customers, but TI does not recommend using this part in a new design.

**PREVIEW:** Device has been announced but is not in production. Samples may or may not be available.

**OBSOLETE:** TI has discontinued the production of the device.

(2) **RoHS:** TI defines "RoHS" to mean semiconductor products that are compliant with the current EU RoHS requirements for all 10 RoHS substances, including the requirement that RoHS substance do not exceed 0.1% by weight in homogeneous materials. Where designed to be soldered at high temperatures, "RoHS" products are suitable for use in specified lead-free processes. TI may reference these types of products as "Pb-Free".

**RoHS Exempt:** TI defines "RoHS Exempt" to mean products that contain lead but are compliant with EU RoHS pursuant to a specific EU RoHS exemption.

**Green:** TI defines "Green" to mean the content of Chlorine (Cl) and Bromine (Br) based flame retardants meet JS709B low halogen requirements of  $\leq 1000$ ppm threshold. Antimony trioxide based flame retardants must also meet the  $\leq 1000$ ppm threshold requirement.

(3) **MSL, Peak Temp.** - The Moisture Sensitivity Level rating according to the JEDEC industry standard classifications, and peak solder temperature.

(4) There may be additional marking, which relates to the logo, the lot trace code information, or the environmental category on the device.

(5) Multiple Device Markings will be inside parentheses. Only one Device Marking contained in parentheses and separated by a "~" will appear on a device. If a line is indented then it is a continuation of the previous line and the two combined represent the entire Device Marking for that device.

(6) **Lead finish/Ball material** - Orderable Devices may have multiple material finish options. Finish options are separated by a vertical ruled line. Lead finish/Ball material values may wrap to two lines if the finish value exceeds the maximum column width.

**Important Information and Disclaimer:**The information provided on this page represents TI's knowledge and belief as of the date that it is provided. TI bases its knowledge and belief on information provided by third parties, and makes no representation or warranty as to the accuracy of such information. Efforts are underway to better integrate information from third parties. TI has taken and continues to take reasonable steps to provide representative and accurate information but may not have conducted destructive testing or chemical analysis on incoming materials and chemicals. TI and TI suppliers consider certain information to be proprietary, and thus CAS numbers and other limited information may not be available for release.

In no event shall TI's liability arising out of such information exceed the total purchase price of the TI part(s) at issue in this document sold by TI to Customer on an annual basis.

#### **OTHER QUALIFIED VERSIONS OF TPS3851-Q1 :**

- Catalog : [TPS3851](#)

NOTE: Qualified Version Definitions:

- Catalog - TI's standard catalog product

**TAPE AND REEL INFORMATION**

**QUADRANT ASSIGNMENTS FOR PIN 1 ORIENTATION IN TAPE**

\*All dimensions are nominal

Device	Package Type	Package Drawing	Pins	SPQ	Reel Diameter (mm)	Reel Width W1 (mm)	A0 (mm)	B0 (mm)	K0 (mm)	P1 (mm)	W (mm)	Pin1 Quadrant
TPS3851G18EQDRBRQ1	SON	DRB	8	3000	330.0	12.4	3.3	3.3	1.1	8.0	12.0	Q2
TPS3851G18SQDRBRQ1	SON	DRB	8	3000	330.0	12.4	3.3	3.3	1.1	8.0	12.0	Q2
TPS3851G25EQDRBRQ1	SON	DRB	8	3000	330.0	12.4	3.3	3.3	1.1	8.0	12.0	Q2
TPS3851G25SQDRBRQ1	SON	DRB	8	3000	330.0	12.4	3.3	3.3	1.1	8.0	12.0	Q2
TPS3851G30EQDRBRQ1	SON	DRB	8	3000	330.0	12.4	3.3	3.3	1.1	8.0	12.0	Q2
TPS3851G30SQDRBRQ1	SON	DRB	8	3000	330.0	12.4	3.3	3.3	1.1	8.0	12.0	Q2
TPS3851G33EQDRBRQ1	SON	DRB	8	3000	330.0	12.4	3.3	3.3	1.1	8.0	12.0	Q2
TPS3851G33SQDRBRQ1	SON	DRB	8	3000	330.0	12.4	3.3	3.3	1.1	8.0	12.0	Q2
TPS3851G50EQDRBRQ1	SON	DRB	8	3000	330.0	12.4	3.3	3.3	1.1	8.0	12.0	Q2
TPS3851G50SQDRBRQ1	SON	DRB	8	3000	330.0	12.4	3.3	3.3	1.1	8.0	12.0	Q2
TPS3851H18EQDRBRQ1	SON	DRB	8	3000	330.0	12.4	3.3	3.3	1.1	8.0	12.0	Q2
TPS3851H18SQDRBRQ1	SON	DRB	8	3000	330.0	12.4	3.3	3.3	1.1	8.0	12.0	Q2
TPS3851H25EQDRBRQ1	SON	DRB	8	3000	330.0	12.4	3.3	3.3	1.1	8.0	12.0	Q2
TPS3851H25SQDRBRQ1	SON	DRB	8	3000	330.0	12.4	3.3	3.3	1.1	8.0	12.0	Q2
TPS3851H30EQDRBRQ1	SON	DRB	8	3000	330.0	12.4	3.3	3.3	1.1	8.0	12.0	Q2
TPS3851H30SQDRBRQ1	SON	DRB	8	3000	330.0	12.4	3.3	3.3	1.1	8.0	12.0	Q2

Device	Package Type	Package Drawing	Pins	SPQ	Reel Diameter (mm)	Reel Width W1 (mm)	A0 (mm)	B0 (mm)	K0 (mm)	P1 (mm)	W (mm)	Pin1 Quadrant
TPS3851H33EQDRBRQ1	SON	DRB	8	3000	330.0	12.4	3.3	3.3	1.1	8.0	12.0	Q2
TPS3851H33SQDRBRQ1	SON	DRB	8	3000	330.0	12.4	3.3	3.3	1.1	8.0	12.0	Q2
TPS3851H50EQDRBRQ1	SON	DRB	8	3000	330.0	12.4	3.3	3.3	1.1	8.0	12.0	Q2
TPS3851H50SQDRBRQ1	SON	DRB	8	3000	330.0	12.4	3.3	3.3	1.1	8.0	12.0	Q2

**TAPE AND REEL BOX DIMENSIONS**

\*All dimensions are nominal

Device	Package Type	Package Drawing	Pins	SPQ	Length (mm)	Width (mm)	Height (mm)
TPS3851G18EQDRBRQ1	SON	DRB	8	3000	367.0	367.0	35.0
TPS3851G18SQDRBRQ1	SON	DRB	8	3000	367.0	367.0	35.0
TPS3851G25EQDRBRQ1	SON	DRB	8	3000	367.0	367.0	35.0
TPS3851G25SQDRBRQ1	SON	DRB	8	3000	367.0	367.0	35.0
TPS3851G30EQDRBRQ1	SON	DRB	8	3000	367.0	367.0	35.0
TPS3851G30SQDRBRQ1	SON	DRB	8	3000	367.0	367.0	35.0
TPS3851G33EQDRBRQ1	SON	DRB	8	3000	367.0	367.0	35.0
TPS3851G33SQDRBRQ1	SON	DRB	8	3000	367.0	367.0	35.0
TPS3851G50EQDRBRQ1	SON	DRB	8	3000	367.0	367.0	35.0
TPS3851G50SQDRBRQ1	SON	DRB	8	3000	367.0	367.0	35.0
TPS3851H18EQDRBRQ1	SON	DRB	8	3000	367.0	367.0	35.0
TPS3851H18SQDRBRQ1	SON	DRB	8	3000	367.0	367.0	35.0
TPS3851H25EQDRBRQ1	SON	DRB	8	3000	367.0	367.0	35.0
TPS3851H25SQDRBRQ1	SON	DRB	8	3000	367.0	367.0	35.0
TPS3851H30EQDRBRQ1	SON	DRB	8	3000	367.0	367.0	35.0
TPS3851H30SQDRBRQ1	SON	DRB	8	3000	367.0	367.0	35.0
TPS3851H33EQDRBRQ1	SON	DRB	8	3000	367.0	367.0	35.0
TPS3851H33SQDRBRQ1	SON	DRB	8	3000	367.0	367.0	35.0

---

Device	Package Type	Package Drawing	Pins	SPQ	Length (mm)	Width (mm)	Height (mm)
TPS3851H50EQDRBRQ1	SON	DRB	8	3000	367.0	367.0	35.0
TPS3851H50SQDRBRQ1	SON	DRB	8	3000	367.0	367.0	35.0

**DRB 8**

**GENERIC PACKAGE VIEW**

**VSON - 1 mm max height**

PLASTIC SMALL OUTLINE - NO LEAD



Images above are just a representation of the package family, actual package may vary.  
Refer to the product data sheet for package details.

4203482/L

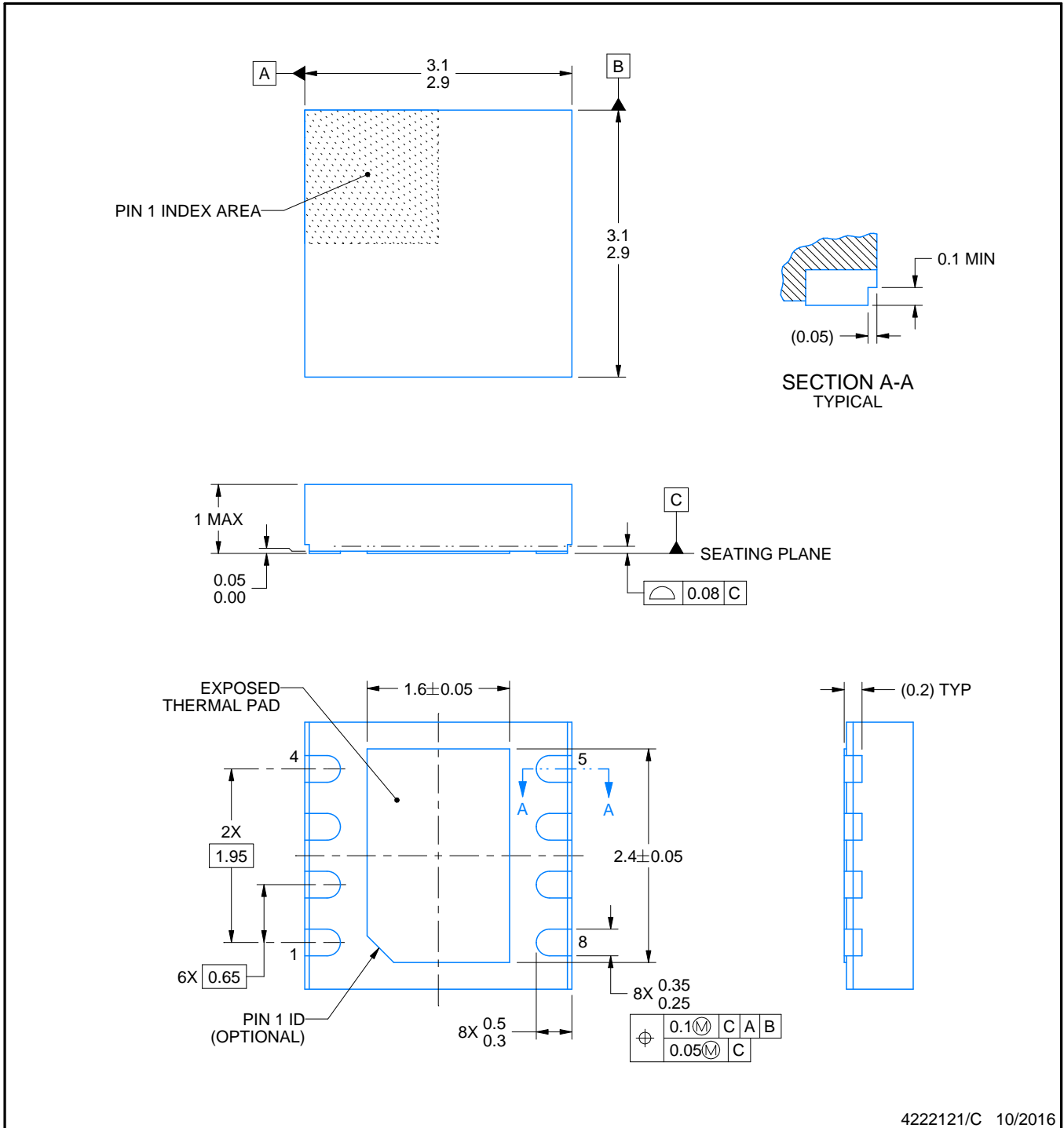

4222121/C 10/2016

NOTES:

1. All linear dimensions are in millimeters. Any dimensions in parenthesis are for reference only. Dimensioning and tolerancing per ASME Y14.5M.
2. This drawing is subject to change without notice.
3. The package thermal pad must be soldered to the printed circuit board for thermal and mechanical performance.



# EXAMPLE BOARD LAYOUT

DRB0008F

VSON - 1 mm max height

PLASTIC SMALL OUTLINE - NO LEAD

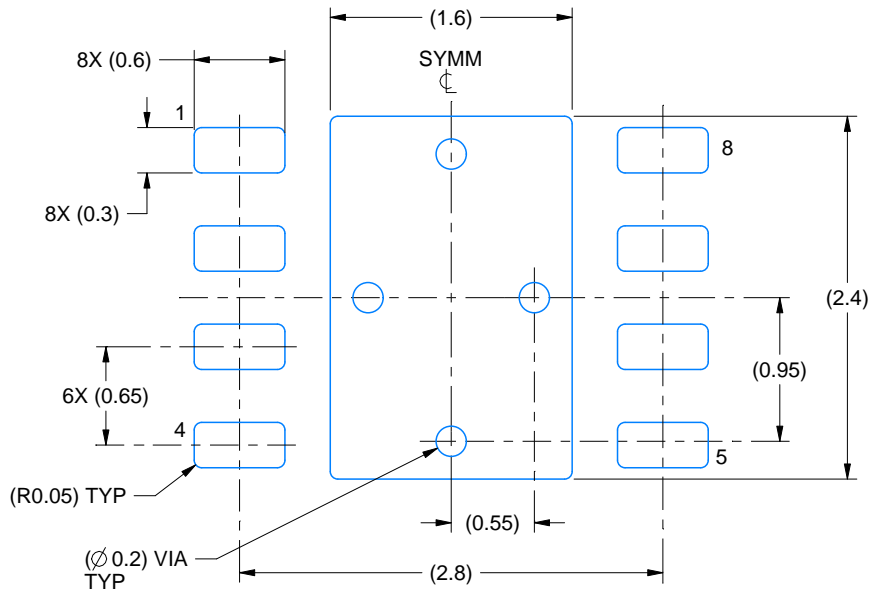

LAND PATTERN EXAMPLE  
SCALE:20X

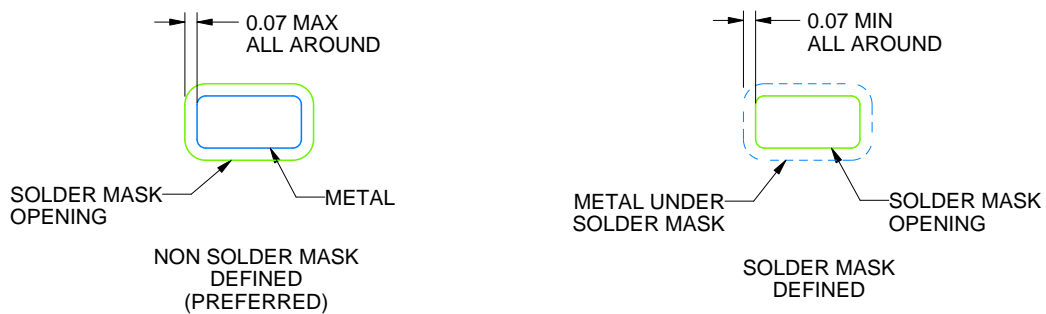

SOLDER MASK DETAILS

4222121/C 10/2016

NOTES: (continued)

4. This package is designed to be soldered to a thermal pad on the board. For more information, see Texas Instruments literature number SLUA271 ([www.ti.com/lit/sluea271](http://www.ti.com/lit/sluea271)).
5. Vias are optional depending on application, refer to device data sheet. If any vias are implemented, refer to their locations shown on this view. It is recommended that vias under paste be filled, plugged or tented.

# EXAMPLE STENCIL DESIGN

DRB0008F

VSON - 1 mm max height

PLASTIC SMALL OUTLINE - NO LEAD

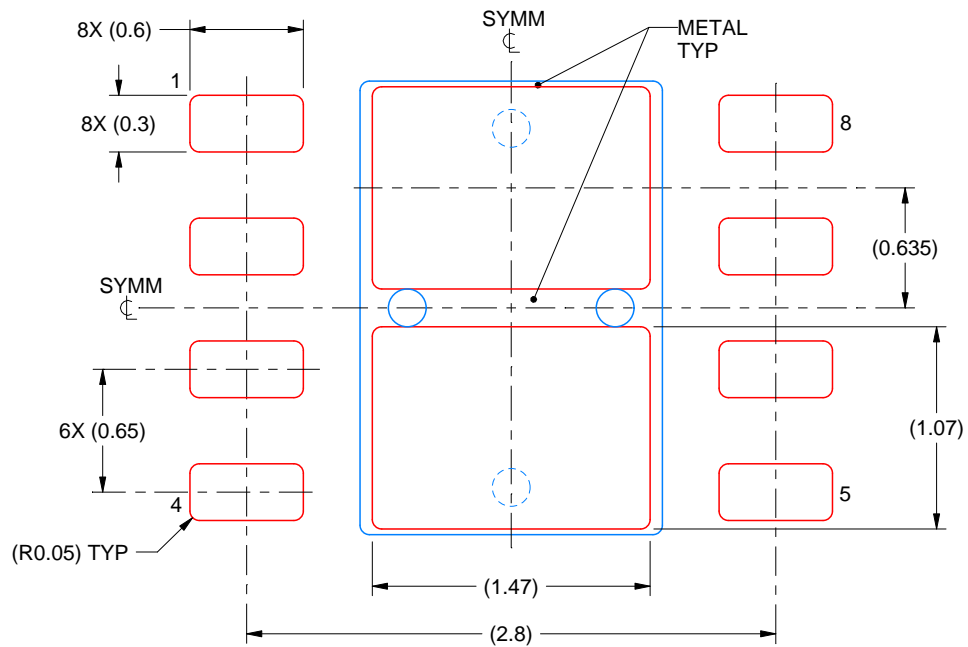

SOLDER PASTE EXAMPLE  
BASED ON 0.125 mm THICK STENCIL

EXPOSED PAD  
82% PRINTED SOLDER COVERAGE BY AREA  
SCALE:25X

4222121/C 10/2016

NOTES: (continued)

6. Laser cutting apertures with trapezoidal walls and rounded corners may offer better paste release. IPC-7525 may have alternate design recommendations.

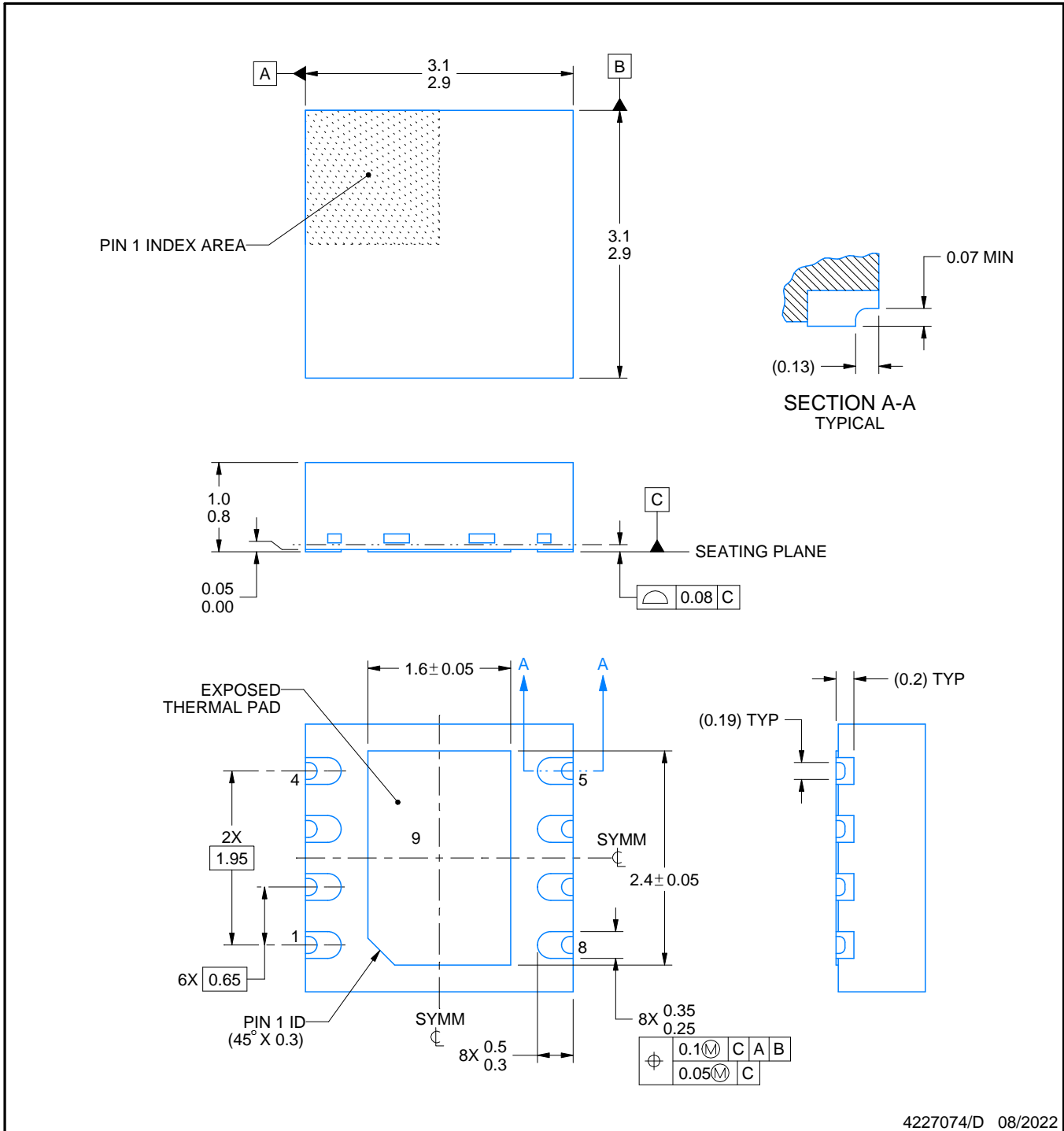

4227074/D 08/2022

NOTES:

1. All linear dimensions are in millimeters. Any dimensions in parenthesis are for reference only. Dimensioning and tolerancing per ASME Y14.5M.
2. This drawing is subject to change without notice.
3. The package thermal pad must be soldered to the printed circuit board for optimal thermal and mechanical performance.

# EXAMPLE BOARD LAYOUT

DRB0008K

VSON - 1 mm max height

PLASTIC SMALL OUTLINE - NO LEAD

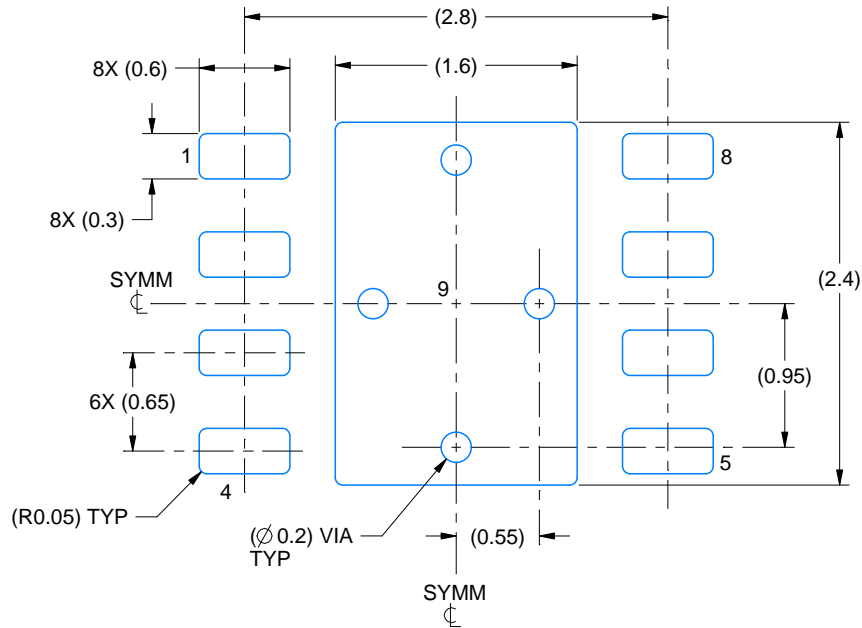

LAND PATTERN EXAMPLE  
EXPOSED METAL SHOWN  
SCALE:20X

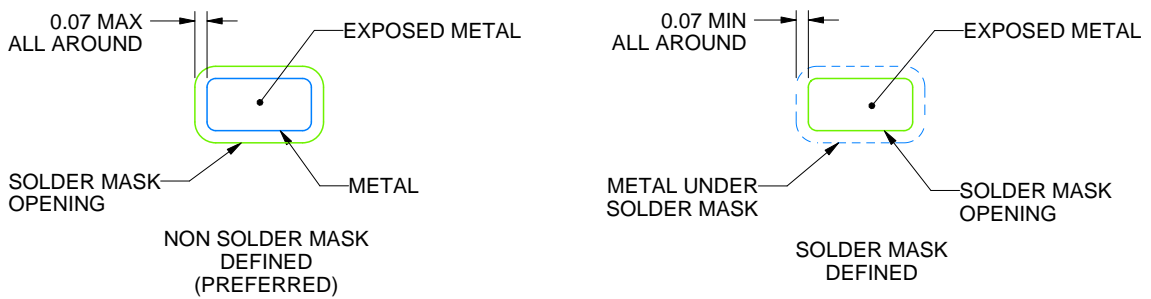

SOLDER MASK DETAILS

4227074/D 08/2022

NOTES: (continued)

4. This package is designed to be soldered to a thermal pad on the board. For more information, see Texas Instruments literature number SLUA271 ([www.ti.com/lit/sluea271](http://www.ti.com/lit/sluea271)).
5. Vias are optional depending on application, refer to device data sheet. If any vias are implemented, refer to their locations shown on this view. It is recommended that vias under paste be filled, plugged or tented.

# EXAMPLE STENCIL DESIGN

DRB0008K

VSON - 1 mm max height

PLASTIC SMALL OUTLINE - NO LEAD

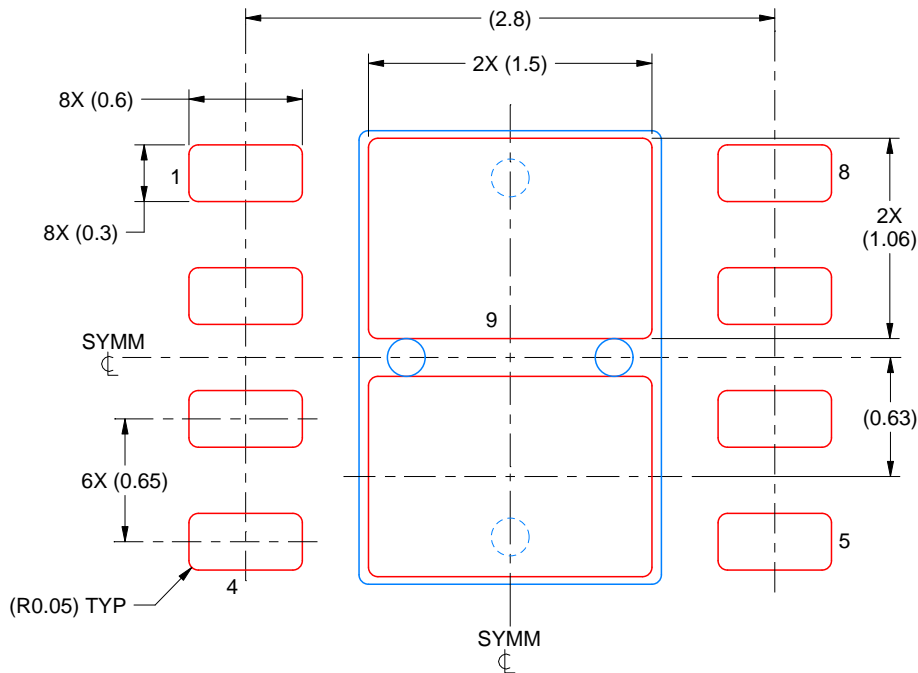

SOLDER PASTE EXAMPLE  
BASED ON 0.125 mm THICK STENCIL

EXPOSED PAD 9:  
80% PRINTED SOLDER COVERAGE BY AREA  
SCALE:25X

4227074/D 08/2022

NOTES: (continued)

6. Laser cutting apertures with trapezoidal walls and rounded corners may offer better paste release. IPC-7525 may have alternate design recommendations.

## 重要なお知らせと免責事項

TI は、技術データと信頼性データ (データシートを含みます)、設計リソース (リファレンス・デザインを含みます)、アプリケーションや設計に関する各種アドバイス、Web ツール、安全性情報、その他のリソースを、欠陥が存在する可能性のある「現状のまま」提供しており、商品性および特定目的に対する適合性の黙示保証、第三者の知的財産権の非侵害保証を含むいかなる保証も、明示的または黙示的にかかわらず拒否します。

これらのリソースは、TI 製品を使用する設計の経験を積んだ開発者への提供を意図したものです。(1) お客様のアプリケーションに適した TI 製品の選定、(2) お客様のアプリケーションの設計、検証、試験、(3) お客様のアプリケーションに該当する各種規格や、その他のあらゆる安全性、セキュリティ、規制、または他の要件への確実な適合に関する責任を、お客様のみが単独で負うものとし、

上記の各種リソースは、予告なく変更される可能性があります。これらのリソースは、リソースで説明されている TI 製品を使用するアプリケーションの開発の目的でのみ、TI はその使用をお客様に許諾します。これらのリソースに関して、他の目的で複製することや掲載することは禁止されています。TI や第三者の知的財産権のライセンスが付与されている訳ではありません。お客様は、これらのリソースを自身で使用した結果発生するあらゆる申し立て、損害、費用、損失、責任について、TI およびその代理人を完全に補償するものとし、TI は一切の責任を拒否します。

TI の製品は、[TI の販売条件](#)、または [ti.com](https://www.ti.com) やかかる TI 製品の関連資料などのいずれかを通じて提供する適用可能な条項の下で提供されています。TI がこれらのリソースを提供することは、適用される TI の保証または他の保証の放棄の拡大や変更を意味するものではありません。

お客様がいかなる追加条項または代替条項を提案した場合でも、TI はそれらに異議を唱え、拒否します。

郵送先住所 : Texas Instruments, Post Office Box 655303, Dallas, Texas 75265  
Copyright © 2023, Texas Instruments Incorporated