

ADS1278-SP 放射線耐性を強化した8チャンネル同時サンプリング、 24ビットのアナログ/デジタル・コンバータ

1 特長

- 放射線耐性を強化
 - TID: 75krad(Si)
 - TID RLAT (Radiation Lot Acceptance Test): 未定
 - 単一イベント・ラッチアップ(SEL)耐性: LET = 68MeV·cm²/mg (125°C)
- 8つのチャンネルを同時にサンプリング
- 最大128kSPSのデータ・レート
- AC特性
 - 帯域幅: 63kHz
 - SNR: 111dB (高分解能モード)
 - THD: -108dB
- DC精度
 - オフセット・ドリフト: 0.8μV/°C
 - ゲイン・ドリフト: 1.3ppm/°C
- 動作モードを選択可能
 - 高速: 128kSPS、SNR 106dB
 - 高分解能: 52kSPS、SNR 111dB
 - 低消費電力: 52kSPS、31mW/ch
 - 低速: 10kSPS、7mW/ch
- 線形位相デジタル・フィルタ
- SPI™またはフレーム同期シリアル・インターフェイス
- 小さいサンプリング・アパーチャ誤差
- 変調器出力オプション (デジタル・フィルタ・バイパス)
- アナログ電源: 5V
- デジタル・コア: 1.8V
- I/O電源: 1.8V~3.3V

2 アプリケーション

- 宇宙用システム (人工衛星、シャトル、ステーション)
 - 人工衛星の温度および位置センシング
 - 軌道観測システム
 - 高精度および科学用アプリケーション
 - 高精度の計測機器

3 概要

ADS1278-SP (オクタール) は24ビット、デルタ-シグマ($\Delta\Sigma$)アナログ/デジタル・コンバータ(ADC)で、最高128kサンプル/秒(SPS)のデータ速度を実現し、8チャンネルを同時にサンプリング可能です。

従来、ドリフト性能が優れた産業用デルタ-シグマADCは、パスバンド・ドループが大きいデジタル・フィルタを使用していました。その結果、信号の帯域幅が限られており、主にDC測定に適していました。オーディオ・アプリケーションの高分解能ADCは、使用可能な帯域幅の点で優れていますが、オフセットおよびドリフトの仕様については、対応する産業用部品より大きく劣っています。ADS1278-SPはこれらのタイプのコンバータを組み合わせることで、優れたDCおよびAC仕様の高精度産業用計測を可能にしています。

製品情報(1)

型番	グレード	パッケージ
ADS1278MHFQ-MLS	フライト・グレード: 75krad (Si)、-55°C~125°C	84ピンHFQ 重量: 4.46g ⁽³⁾
ADS1278WHFQ-MLS	フライト・グレード: 75krad (Si)、-55°C~115°C	
ADS1278HFQ/EM	エンジニアリング・サンプル (2)	
ADS1278EVM-CVAL	セラミック評価ボード	EVM

- 利用可能なすべてのパッケージについては、このデータシートの末尾にある注文情報を参照してください。
- これらのユニットは、技術的な評価のみを目的としています。標準とは異なるフローに従って処理されています。これらのユニットは、認定、量産、放射線テスト、航空での使用には適していません。これらの部品は、MILに規定されている温度範囲-55°C~125°C、または動作寿命全体にわたる性能を保証されていません。
- 重量の精度は ±10% です。

概略回路図

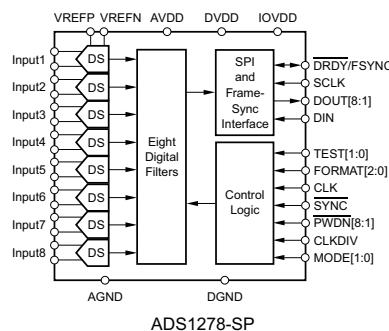

目次

1	特長	1	8.2	Functional Block Diagram	23
2	アプリケーション	1	8.3	Feature Description	23
3	概要	1	8.4	Device Functional Modes	45
4	改訂履歴	2	9	Application and Implementation	46
5	概要 (続き)	3	9.1	Application Information	46
6	Pin Configuration and Functions	3	9.2	Typical Application	46
7	Specifications	6	10	Power Supply Recommendations	49
7.1	Absolute Maximum Ratings	6	11	Layout	50
7.2	ESD Ratings	6	11.1	Layout Guidelines	50
7.3	Recommended Operating Conditions	6	11.2	Layout Example	51
7.4	Thermal Information	6	12	デバイスおよびドキュメントのサポート	52
7.5	Electrical Characteristics	7	12.1	ドキュメントの更新通知を受け取る方法	52
7.6	Timing Requirements: SPI Format	9	12.2	コミュニティ・リソース	52
7.7	Timing Requirements: Frame-Sync Format	11	12.3	商標	52
7.8	Quality Conformance Inspection	11	12.4	静電気放電に関する注意事項	52
7.9	Typical Characteristics	13	12.5	Glossary	52
8	Detailed Description	22	13	メカニカル、パッケージ、および注文情報	53
8.1	Overview	22			

4 改訂履歴

資料番号末尾の英字は改訂を表しています。その改訂履歴は英語版に準じています。

Revision A (December 2018) から Revision B に変更

Page

•	事前情報から量産データに変更	3
---	----------------------	---

5 概要 (続き)

高次のチョップ安定化変調器は、小さな帯域内ノイズで非常に小さなドリフトを達成します。オンボードのデシメーション・フィルタは、変調器と信号の帯域外ノイズを抑制します。これらのADCは、使用可能な信号帯域幅がナイキスト・レートの最大90%、リップルは0.005dB未満です。

4つの動作モードにより、速度、分解能、消費電力を最適化できます。すべての動作はピンで直接制御でき、レジスタをプログラムする必要はありません。このデバイスは拡張温度範囲の-55°C~125°Cで完全に動作が規定されており、84ピンのHFQパッケージで供給されます。

6 Pin Configuration and Functions

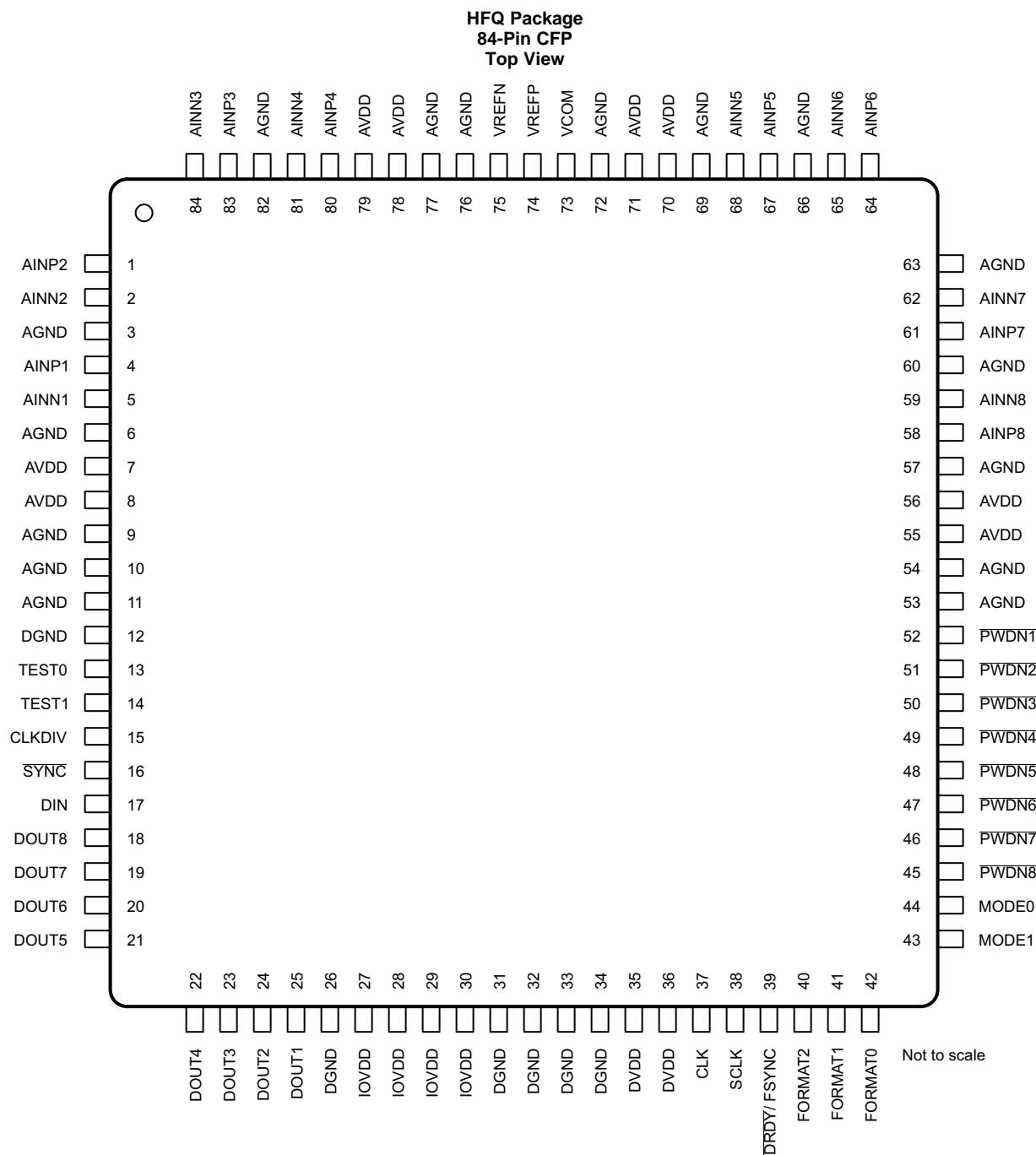

Pin Functions

PIN		I/O	DESCRIPTION
NAME	NO.		
AGND	3, 6, 9, 10, 11, 53, 54, 57, 60, 63, 66, 69, 72, 76, 77, 82	Analog ground	Analog ground; connect to DGND using a single plane.
AINP1	4	Analog input	AINP[8:1] Positive analog input, channels 8 through 1.
AINP2	1	Analog input	
AINP3	83	Analog input	
AINP4	80	Analog input	
AINP5	67	Analog input	
AINP6	64	Analog input	
AINP7	61	Analog input	
AINP8	58	Analog input	
AINN1	5	Analog input	AINN[8:1] Negative analog input, channels 8 through 1.
AINN2	2	Analog input	
AINN3	84	Analog input	
AINN4	81	Analog input	
AINN5	68	Analog input	
AINN6	65	Analog input	
AINN7	62	Analog input	
AINN8	59	Analog input	
AVDD	7, 8, 55, 56, 70, 71, 78, 79	Analog power supply	Analog power supply (4.75 V to 5.25 V).
VCOM	73	Analog output	AVDD / 2 Unbuffered voltage output.
VREFN	75	Analog input	Negative reference input.
VREFP	74	Analog input	Positive reference input.
CLK	37	Digital input	Master clock input.
CLKDIV	15	Digital input	CLK input divider control: 1 = 32.768 MHz (High-Speed mode only) / 27 MHz 0 = 13.5 MHz (low-power) / 5.4 MHz (low-speed)
DGND	12, 26, 31, 32, 33, 34	Digital ground	Digital ground power supply.
DIN	17	Digital input	Daisy-chain data input.
DOUT1	25	Digital output	DOUT[8:1] Data output for channels 8 through 1. DOUT1 is TDM data output (TDM mode).
DOUT2	24	Digital output	
DOUT3	23	Digital output	
DOUT4	22	Digital output	
DOUT5	21	Digital output	
DOUT6	20	Digital output	
DOUT7	19	Digital output	
DOUT8	18	Digital output	
$\overline{\text{DRDY}}$ / FSYNC	39	Digital input/output	Frame-Sync protocol: frame clock input; SPI protocol: data ready output.
DVDD	35, 36	Digital power supply	Digital core power supply (+1.65 V to +1.95 V).
FORMAT0	42	Digital input	FORMAT[2:0] Selects Frame-Sync/SPI protocol, TDM/discrete data outputs, fixed/dynamic position TDM data, and modulator mode/normal operating mode.
FORMAT1	41	Digital input	
FORMAT2	40	Digital input	
IOVDD	27, 28, 29, 30	Digital power supply	I/O power supply (+1.65 V to +3.6 V).

7 Specifications

7.1 Absolute Maximum Ratings

over operating free-air temperature range (unless otherwise noted)⁽¹⁾

		MIN	MAX	UNIT
AVDD to AGND		-0.3	6	V
AGND to DGND		-0.3	0.3	V
DVDD, IOVDD to DGND		-0.3	3.6	V
Input current	Momentary	100		mA
	Continuous	10		
Analog input to AGND		-0.3	AVDD + 0.3	V
Digital input or output to DGND		-0.3	DVDD + 0.3	V
Junction temperature	HFQ and HKP Packages	-55	217	°C
	D Package	-55	175	
Storage temperature, T _{stg}		-60	150	°C

(1) Stresses beyond those listed under *Absolute Maximum Ratings* may cause permanent damage to the device. These are stress ratings only, which do not imply functional operation of the device at these or any other conditions beyond those indicated under *Recommended Operating Conditions*. Exposure to absolute-maximum-rated conditions for extended periods may affect device reliability.

7.2 ESD Ratings

		VALUE	UNIT
V _(ESD) Electrostatic discharge	Human-body model (HBM), per ANSI/ESDA/JEDEC JS-001 ⁽¹⁾	TBD	V
	Charged-device model (CDM), per JEDEC specification JESD22-C101 ⁽²⁾	TBD	

(1) JEDEC document JEP155 states that 500-V HBM allows safe manufacturing with a standard ESD control process.

(2) JEDEC document JEP157 states that 250-V CDM allows safe manufacturing with a standard ESD control process.

7.3 Recommended Operating Conditions

over operating free-air temperature range (unless otherwise noted)

		MIN	NOM	MAX	UNIT
T _J Operating junction temperature	ADS1278MHFQ-MLS	-55		125	°C
	ADS1278WHFQ-MLS	-55		115	

7.4 Thermal Information

THERMAL METRIC ⁽¹⁾		ADS1278-SP	UNIT
		HFQ (CFP)	
		84 PINS	
R _{θJA}	Junction-to-ambient thermal resistance	23.7	°C/W
R _{θJC(top)}	Junction-to-case (top) thermal resistance	9.6	°C/W
R _{θJB}	Junction-to-board thermal resistance	11.5	°C/W
ψ _{JT}	Junction-to-top characterization parameter	3.0	°C/W
ψ _{JB}	Junction-to-board characterization parameter	10.9	°C/W
R _{θJC(bot)}	Junction-to-case (bottom) thermal resistance	7.7	°C/W

(1) For more information about traditional and new thermal metrics, see the [Semiconductor and IC Package Thermal Metrics](#) application report.

7.5 Electrical Characteristics

All specifications at $T_A = -55^\circ\text{C}$ to 125°C , $AVDD = 5\text{ V}$, $DVDD = 1.8\text{ V}$, $IOVDD = 3.3\text{ V}$, $f_{\text{CLK}} = 27\text{ MHz}$, $V_{\text{REFP}} = 2.5\text{ V}$, $V_{\text{REFN}} = 0\text{ V}$, and all channels active, unless otherwise noted.

PARAMETER	TEST CONDITIONS	SUBGROUP (1)(2)	-55°C to +125°C (ADS1278MHFQ-MLS)			-55°C to +115°C (ADS1278WHFQ-MLS)			UNIT
			MIN	TYP	MAX	MIN	TYP	MAX	
ANALOG INPUTS									
Full-scale input voltage (FSR ⁽³⁾)	$V_{\text{IN}} = (\text{AINP} - \text{AINN})$		$\pm V_{\text{REF}}$			$\pm V_{\text{REF}}$			V
Absolute input voltage	AINP or AINN to AGND	1, 2, 3	AGND – 0.1		AVDD + 0.1	AGND – 0.1		AVDD + 0.1	V
Common-mode input voltage (V_{CM})	$V_{\text{CM}} = (\text{AINP} + \text{AINN}) / 2$		2.5			2.5			V
Differential input impedance	High-Speed mode		14			14			kΩ
	High-Resolution mode		14			14			
	Low-Power mode		28			28			
	Low-Speed mode		140			140			
DC PERFORMANCE									
Resolution	No missing codes	1, 2, 3	24			24			Bits
Maximum data rate (f_{DATA})	High-Speed mode	$f_{\text{CLK}} = 32.768\text{ MHz}^{(4)}$	128,000			128,000			SPS ⁽⁵⁾
		$f_{\text{CLK}} = 27\text{ MHz}$	105,469			105,469			
	High-Resolution mode	52,734			52,734				
	Low-Speed mode	10,547			10,547				
Integral nonlinearity (INL) ⁽⁶⁾	Differential input, $V_{\text{CM}} = 2.5\text{ V}$	1, 2, 3	± 0.0003	$\pm 0.001_2$		± 0.0003	$\pm 0.001_2$	% FSR ⁽³⁾	
Offset error		1, 2, 3	0.25	2		0.25	2	mV	
Offset drift			0.8			0.8			$\mu\text{V}/^\circ\text{C}$
Gain error		1, 2, 3	0.1	0.5		0.1	0.5	% FSR	
Gain drift			1.3			1.3			$\text{ppm}/^\circ\text{C}$
Noise	High-Speed mode	Shorted input	1, 2, 3	8.5	23	8.5	21	μV , rms	
	High-Resolution mode	Shorted input	1, 2, 3	5.5	14	5.5	13		
	Low-Power mode	Shorted input	1, 2, 3	8.5	23	8.5	21		
	Low-Speed mode	Shorted input	1, 2, 3	8.0	23	8.0	21		
Common-mode rejection	$f_{\text{CM}} = 60\text{ Hz}$	1, 2, 3	90	108		90	108	dB	
Power-supply rejection	AVDD	$f_{\text{PS}} = 60\text{ Hz}$	80			80			dB
	DVDD		85			85			
	IOVDD		105			105			
V_{COM} output voltage	No load		$AVDD / 2$			$AVDD / 2$			V
AC PERFORMANCE									
Crosstalk	$f = 1\text{ kHz}$, $-0.5\text{ dBFS}^{(7)}$		-107			-107			dB
Signal-to-noise ratio (SNR) ⁽⁸⁾ (unweighted)	High-Speed mode		4, 5, 6	98	106	98	106	dB	
	High-Resolution mode	$V_{\text{REF}} = 2.5\text{ V}$	4, 5, 6	101	110	101	110		
		$V_{\text{REF}} = 3\text{ V}$					111		
	Low-Speed mode		4, 5, 6	98	106	98	106		
Total harmonic distortion (THD) ⁽⁹⁾	$V_{\text{IN}} = 1\text{ kHz}$, -0.5 dBFS	4, 5, 6	-108	-96		-108	-96	dB	
Spurious-free dynamic range			109			109			dB

(1) For subgroup definitions, please see [Quality Conformance Inspection](#) table.

(2) Subgroups apply to **-55°C to +125°C** column only.

(3) FSR = full-scale range = $2 V_{\text{REF}}$.

(4) $f_{\text{CLK}} = 32.768\text{-MHz}$ max for High-Speed mode and 27-MHz max for all other modes. When $f_{\text{CLK}} > 27\text{ MHz}$, operation is limited to Frame-Sync mode and $V_{\text{REF}} \leq 2.6\text{ V}$.

(5) SPS = samples per second.

(6) Best fit method.

(7) Worst-case channel crosstalk between one or more channels.

(8) Minimum SNR is ensured by the limit of the *DC noise* specification.

(9) THD includes the first nine harmonics of the input signal; Low-Speed mode includes the first five harmonics.

Electrical Characteristics (continued)

All specifications at $T_A = -55^\circ\text{C}$ to 125°C , $AVDD = 5\text{ V}$, $DVDD = 1.8\text{ V}$, $IOVDD = 3.3\text{ V}$, $f_{\text{CLK}} = 27\text{ MHz}$, $V_{\text{REFP}} = 2.5\text{ V}$, $V_{\text{REFN}} = 0\text{ V}$, and all channels active, unless otherwise noted.

PARAMETER	TEST CONDITIONS	SUBGROUP (1)(2)	-55°C to +125°C (ADS1278MHFQ-MLS)			-55°C to +115°C (ADS1278WHFQ-MLS)			UNIT
			MIN	TYP	MAX	MIN	TYP	MAX	
Passband ripple			±0.005			±0.005			dB
Passband			0.453 f_{DATA}			0.453 f_{DATA}			Hz
-3-dB bandwidth			0.49 f_{DATA}			0.49 f_{DATA}			Hz
Stop band attenuation	High-Resolution mode	4, 5, 6	95			95			dB
	All other modes	4, 5, 6	100			100			dB
Stop band	High-Resolution mode	4, 5, 6	0.547 f_{DATA}		127.45 3 f_{DATA}	0.547 f_{DATA}		127.45 3 f_{DATA}	Hz
	All other modes	4, 5, 6	0.547 f_{DATA}		63.453 f_{DATA}	0.547 f_{DATA}		63.453 f_{DATA}	
Group delay	High-Resolution mode		39/ f_{DATA}			39/ f_{DATA}			s
	All other modes		38/ f_{DATA}			38/ f_{DATA}			
Settling time (latency)	High-Resolution mode	Complete settling	78/ f_{DATA}			78/ f_{DATA}			s
	All other modes	Complete settling	76/ f_{DATA}			76/ f_{DATA}			
VOLTAGE REFERENCE INPUTS									
Reference input voltage (V_{REF}) ($V_{\text{REF}} = V_{\text{REFP}} - V_{\text{REFN}}$)	$f_{\text{CLK}} = 27\text{ MHz}$	1, 2, 3	0.5	2.5	3.1	0.5	2.5	3.1	V
	$f_{\text{CLK}} = 32.768\text{ MHz}^{(4)}$	1, 2, 3	0.5	2.5	2.6	0.5	2.5	2.6	
Negative reference input (V_{REFN})		1, 2, 3	AGND – 0.1		AGND + 0.1	AGND – 0.1		AGND + 0.1	V
Positive reference input (V_{REFP})		1, 2, 3	VREFN + 0.5		AVDD + 0.1	VREFN + 0.5		AVDD + 0.1	V
Reference Input impedance	High-Speed mode		0.65			0.65			kΩ
	High-Resolution mode		0.65			0.65			
	Low-Power mode		1.3			1.3			
	Low-Speed mode		6.5			6.5			
DIGITAL INPUT/OUTPUT (IOVDD = 1.8 V to 3.6 V)									
V_{IH}		4, 5, 6	0.7 IOVDD		IOVDD	0.7 IOVDD		IOVDD	V
V_{IL}		4, 5, 6	DGND		0.3 IOVDD	DGND		0.3 IOVDD	V
V_{OH}	$I_{\text{OH}} = 4\text{ mA}$	4, 5, 6	0.8 IOVDD		IOVDD	0.8 IOVDD		IOVDD	V
V_{OL}	$I_{\text{OL}} = 4\text{ mA}$	4, 5, 6	DGND		0.2 IOVDD	DGND		0.2 IOVDD	V
Input leakage	$0 < V_{\text{IN DIGITAL}} < \text{IOVDD}$	4, 5, 6	±11			±10			μA
Master clock rate (f_{CLK})	High-Speed mode ⁽⁴⁾	4, 5, 6	0.1		32.768	0.1		32.768	MHz
	Other modes	1, 2, 3	0.1		27	0.1		27	
POWER SUPPLY									
AVDD		1, 2, 3	4.75	5	5.25	4.75	5	5.25	V
DVDD		1, 2, 3	1.65	1.8	1.95	1.65	1.8	1.95	V
IOVDD		1, 2, 3	1.65		3.6	1.65		3.6	V
Power-down current	AVDD	1, 2, 3	1		11	1		10	μA
	DVDD	1, 2, 3	1		52	1		50	
	IOVDD	1, 2, 3	1		12	1		11	
AVDD current	High-Speed mode	1, 2, 3	97		148	97		145	mA
	High-Resolution mode	1, 2, 3	97		148	97		145	
	Low-Power mode	1, 2, 3	44		66	44		64	
	Low-Speed mode	1, 2, 3	9		15	9		14	

Electrical Characteristics (continued)

All specifications at $T_A = -55^{\circ}\text{C}$ to 125°C , $\text{AVDD} = 5\text{ V}$, $\text{DVDD} = 1.8\text{ V}$, $\text{IOVDD} = 3.3\text{ V}$, $f_{\text{CLK}} = 27\text{ MHz}$, $\text{VREFP} = 2.5\text{ V}$, $\text{VREFN} = 0\text{ V}$, and all channels active, unless otherwise noted.

PARAMETER		TEST CONDITIONS	SUBGROUP (1)(2)	-55°C to +125°C (ADS1278MHFQ-MLS)			-55°C to +115°C (ADS1278WHFQ-MLS)			UNIT
				MIN	TYP	MAX	MIN	TYP	MAX	
DVDD current	High-Speed mode		1, 2, 3		23	31		23	30	mA
	High-Resolution mode		1, 2, 3		16	21		16	20	
	Low-Power mode		1, 2, 3		12	18		12	17	
	Low-Speed mode		1, 2, 3		2.5	5		2.5	4.5	
IOVDD current	High-Speed mode		1, 2, 3		0.25	1.5		0.25	1	mA
	High-Resolution mode		1, 2, 3		0.125	0.8		0.125	0.6	
	Low-Power mode		1, 2, 3		0.125	0.8		0.125	0.6	
	Low-Speed mode		1, 2, 3		0.035	0.5		0.035	0.3	
Power dissipation	High-Speed mode		1, 2, 3		530	805		530	785	mW
	High-Resolution mode		1, 2, 3		515	785		515	765	
	Low-Power mode		1, 2, 3		245	370		245	355	
	Low-Speed mode		1, 2, 3		50	85		50	80	

7.6 Timing Requirements: SPI Format⁽¹⁾

For $T_A = -55^{\circ}\text{C}$ to 125°C , $\text{IOVDD} = 1.65\text{ V}$ to 3.6 V , and $\text{DVDD} = 1.65\text{ V}$ to 1.95 V .

SYMBOL	PARAMETER	MIN	TYP	MAX	UNIT
t_{CLK}	CLK period ($1 / f_{\text{CLK}}$) ⁽²⁾	37		10,000	ns
t_{CPW}	CLK positive or negative pulse width	15			ns
t_{CONV}	Conversion period ($1 / f_{\text{DATA}}$) ⁽³⁾	256		2560	t_{CLK}
t_{CD} ⁽⁴⁾	Falling edge of CLK to falling edge of $\overline{\text{DRDY}}$		22		ns
t_{DS} ⁽⁴⁾	Falling edge of $\overline{\text{DRDY}}$ to rising edge of first SCLK to retrieve data	1			t_{CLK}
t_{MSBPD}	$\overline{\text{DRDY}}$ falling edge to DOUT MSB valid (propagation delay)			16	ns
t_{SD} ⁽⁴⁾	Falling edge of SCLK to rising edge of $\overline{\text{DRDY}}$		18		ns
t_{SCLK} ⁽⁵⁾	SCLK period	1			t_{CLK}
t_{SPW}	SCLK positive or negative pulse width	0.4			t_{CLK}
t_{DOHD} ⁽⁴⁾⁽⁶⁾	SCLK falling edge to new DOUT invalid (hold time)	10			ns
t_{DOPD} ⁽⁴⁾	SCLK falling edge to new DOUT valid (propagation delay)			32	ns
t_{DIST}	New DIN valid to falling edge of SCLK (setup time)	6			ns
t_{DIHD} ⁽⁶⁾	Old DIN valid to falling edge of SCLK (hold time)	6			ns

(1) Timing parameters are characterized or assured by design for specified temperature but not production tested.

(2) $f_{\text{CLK}} = 27\text{-MHz}$ maximum.

(3) Depends on $\text{MODE}[1:0]$ and CLKDIV selection. See [Table 5](#) ($f_{\text{CLK}} / f_{\text{DATA}}$).

(4) Load on $\overline{\text{DRDY}}$ and DOUT = 20 pF.

(5) For best performance, limit $f_{\text{SCLK}} / f_{\text{CLK}}$ to ratios of 1, 1/2, 1/4, 1/8, etc..

(6) t_{DOHD} (DOUT hold time) and t_{DIHD} (DIN hold time) are specified under opposite worst-case conditions (digital supply voltage and ambient temperature). Under equal conditions, with DOUT connected directly to DIN, the timing margin is > 4 ns.

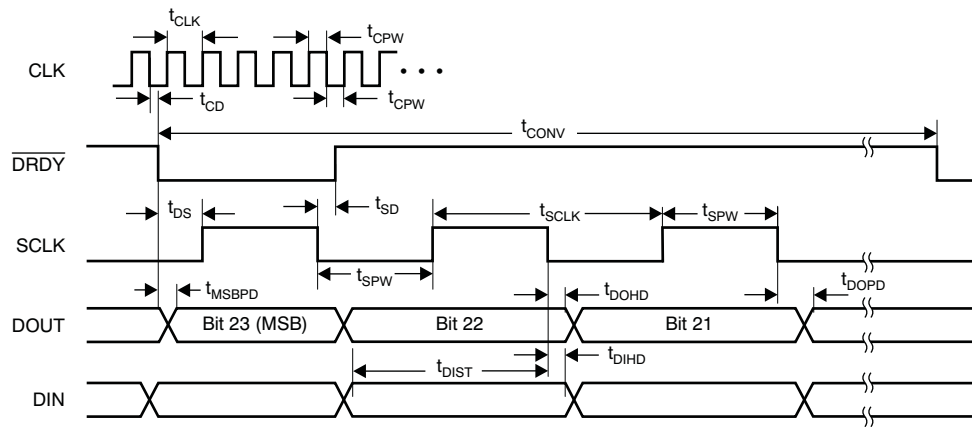

Figure 1. SPI Format Timing Characteristics

7.7 Timing Requirements: Frame-Sync Format⁽¹⁾

over operating free-air temperature range (unless otherwise noted)

SYMBOL	PARAMETER	MIN	TYP	MAX	UNIT
t _{CLK}	CLK period (1 / f _{CLK})	All modes		10,000	ns
		High-Speed mode only		30.5	ns
t _{CPW}	CLK positive or negative pulse width	12			ns
t _{CS}	Falling edge of CLK to falling edge of SCLK	-0.25		0.25	t _{CLK}
t _{FRAME}	Frame period (1 / f _{DATA}) ⁽²⁾	256		2560	t _{CLK}
t _{FPW}	FSYNC positive or negative pulse width	1			t _{SCLK}
t _{FS}	Rising edge of FSYNC to rising edge of SCLK	5			ns
t _{SF}	Rising edge of SCLK to rising edge of FSYNC	5			ns
t _{SCLK}	SCLK period ⁽³⁾	1			t _{CLK}
t _{SPW}	SCLK positive or negative pulse width	0.4			t _{CLK}
t _{DOHD} ⁽⁴⁾ (5)	SCLK falling edge to old DOUT invalid (hold time)	10			ns
t _{DOPD} ⁽⁵⁾	SCLK falling edge to new DOUT valid (propagation delay)			31	ns
t _{MSBPD}	FSYNC rising edge to DOUT MSB valid (propagation delay)			31	ns
t _{DIST}	New DIN valid to falling edge of SCLK (setup time)	6			ns
t _{DIHD} ⁽⁴⁾	Old DIN valid to falling edge of SCLK (hold time)	6			ns

- (1) Timing parameters are characterized or assured by design for specified temperature but not production tested.
- (2) Depends on MODE[1:0] and CLKDIV selection. See Table 5 (f_{CLK} / f_{DATA}).
- (3) SCLK must be continuously running and limited to ratios of 1, 1/2, 1/4, and 1/8 of f_{CLK}.
- (4) t_{DOHD} (DOUT hold time) and t_{DIHD} (DIN hold time) are specified under opposite worst-case conditions (digital supply voltage and ambient temperature). Under equal conditions, with DOUT connected directly to DIN, the timing margin is > 4 ns.
- (5) Load on DOUT = 20 pF.

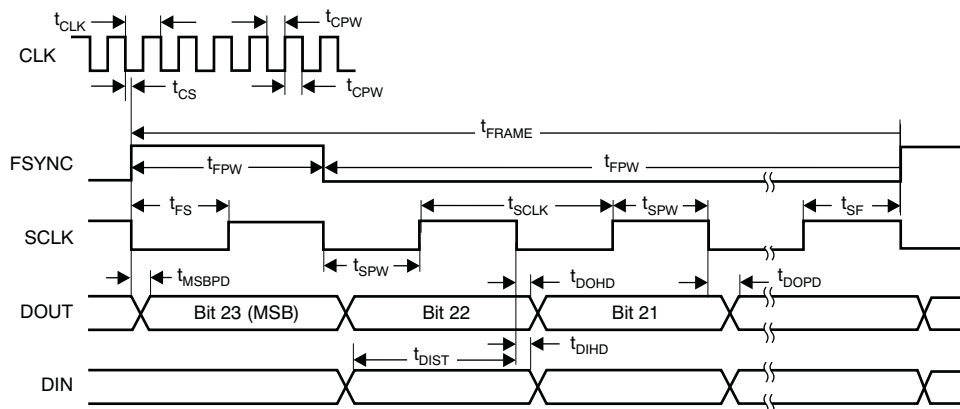

Figure 2. Frame-Sync Format Timing Characteristics

7.8 Quality Conformance Inspection

MIL-STD-883, Method 5005 - Group A

SUBGROUP	DESCRIPTION	TEMP (°C)
1	Static tests at	25
2	Static tests at	125
3	Static tests at	-55
4	Dynamic tests at	25
5	Dynamic tests at	125
6	Dynamic tests at	-55
7	Functional tests at	25

Quality Conformance Inspection (continued)

SUBGROUP	DESCRIPTION	TEMP (°C)
8A	Functional tests at	125
8B	Functional tests at	-55
9	Switching tests at	25
10	Switching tests at	125
11	Switching tests at	-55
12	Setting time at	25
13	Setting time at	125
14	Setting time at	-55

7.9 Typical Characteristics

At $T_A = 25^\circ\text{C}$, High-Speed mode, $AVDD = 5\text{ V}$, $DVDD = 1.8\text{ V}$, $IOVDD = 3.3\text{ V}$, $f_{\text{CLK}} = 27\text{ MHz}$, $V_{\text{REFP}} = 2.5\text{ V}$, and $V_{\text{REFN}} = 0\text{ V}$, unless otherwise noted.

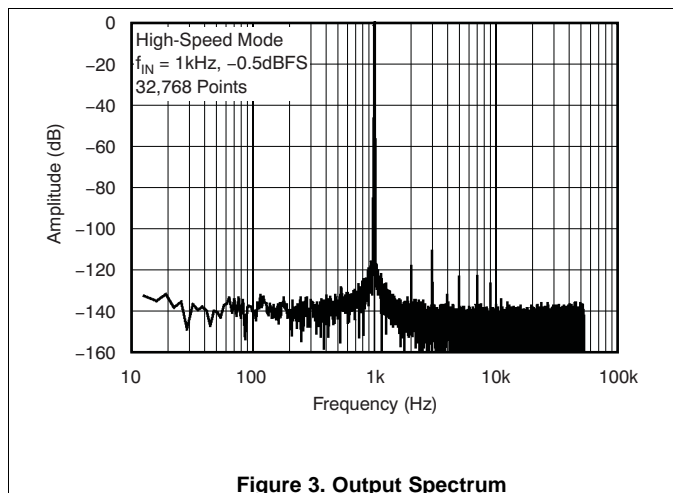

Figure 3. Output Spectrum

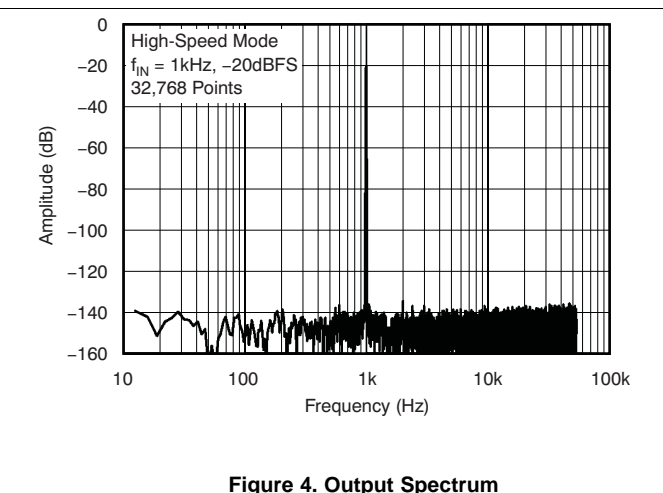

Figure 4. Output Spectrum

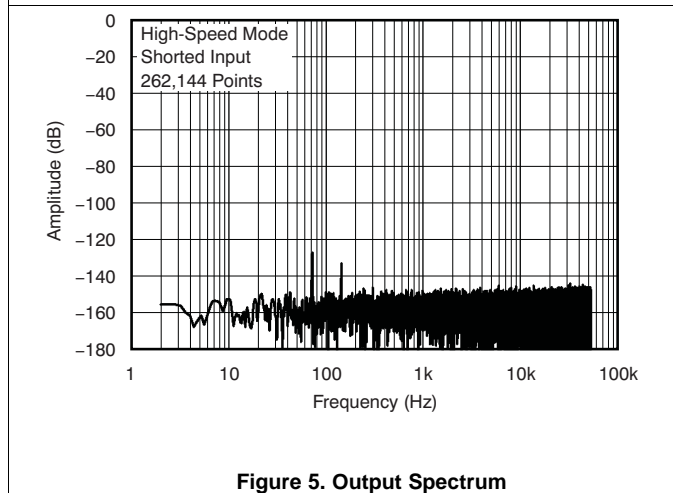

Figure 5. Output Spectrum

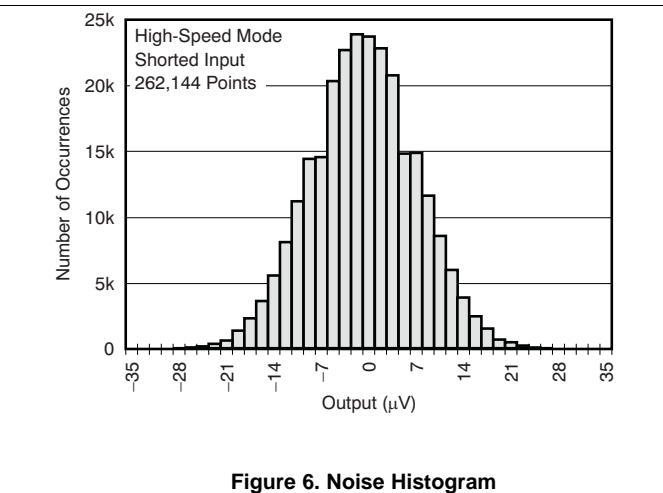

Figure 6. Noise Histogram

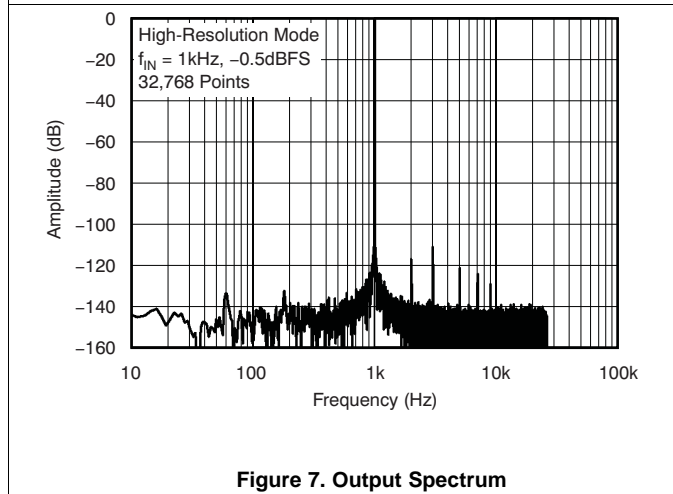

Figure 7. Output Spectrum

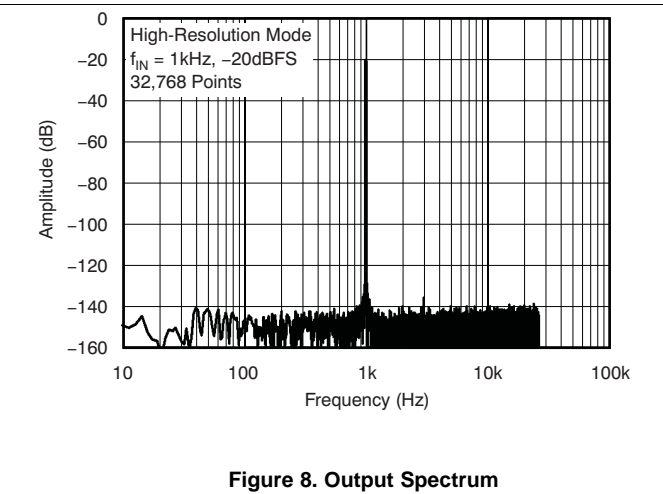

Figure 8. Output Spectrum

Typical Characteristics (continued)

At $T_A = 25^\circ\text{C}$, High-Speed mode, $AVDD = 5\text{ V}$, $DVDD = 1.8\text{ V}$, $IOVDD = 3.3\text{ V}$, $f_{\text{CLK}} = 27\text{ MHz}$, $V_{\text{REFP}} = 2.5\text{ V}$, and $V_{\text{REFN}} = 0\text{ V}$, unless otherwise noted.

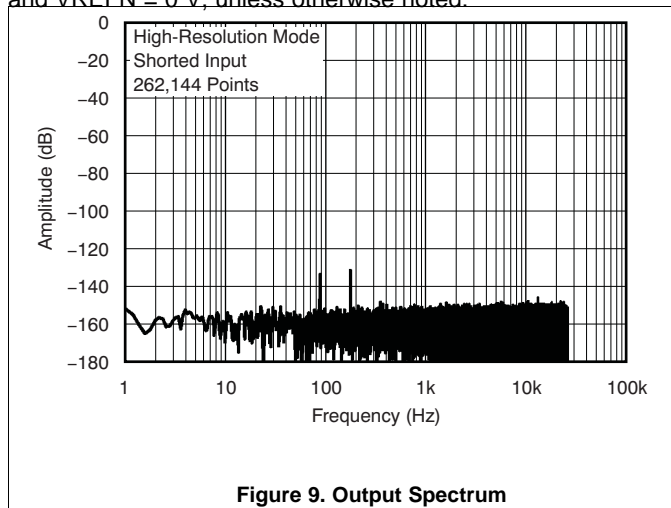

Figure 9. Output Spectrum

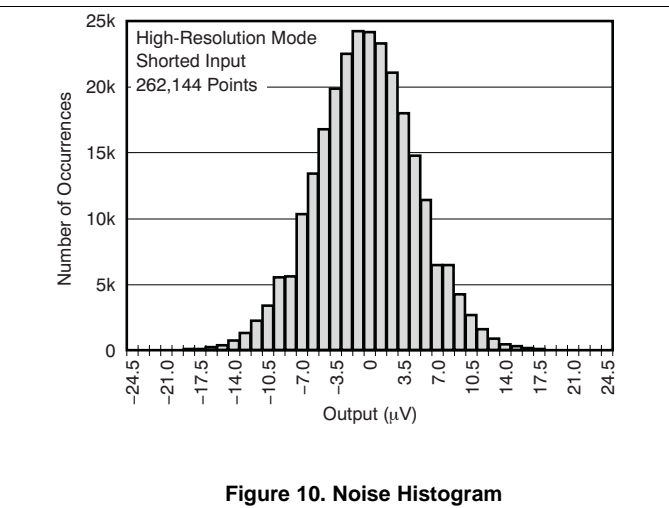

Figure 10. Noise Histogram

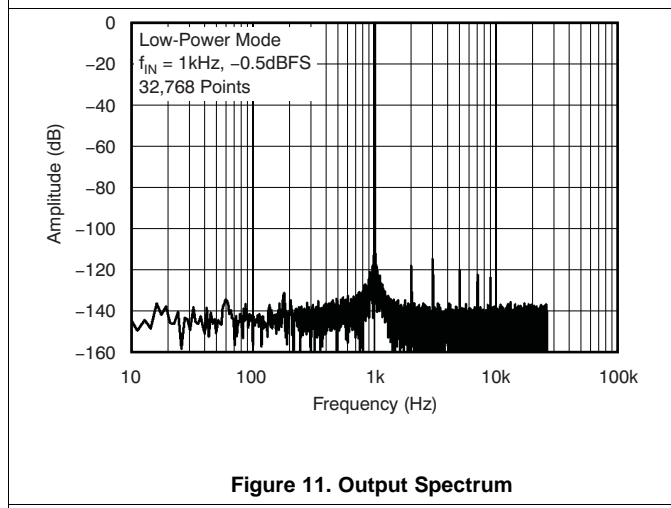

Figure 11. Output Spectrum

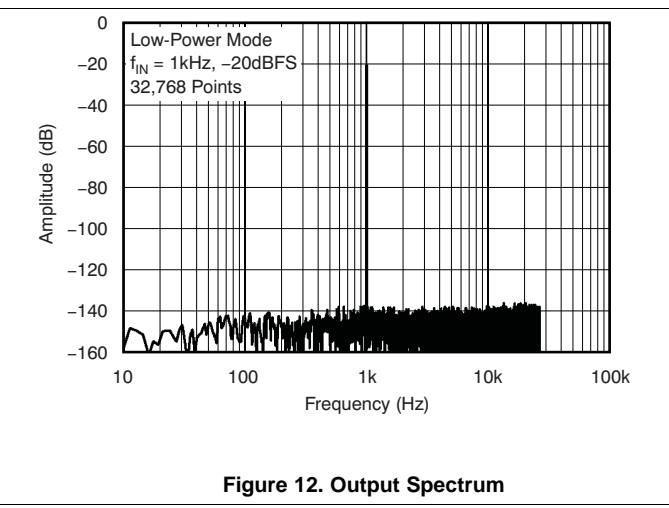

Figure 12. Output Spectrum

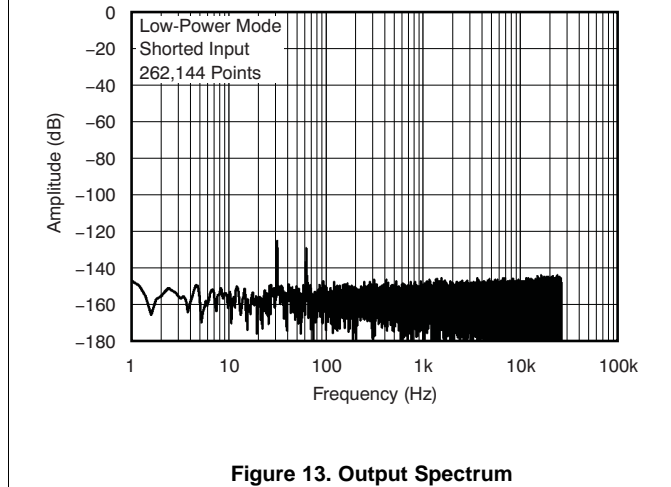

Figure 13. Output Spectrum

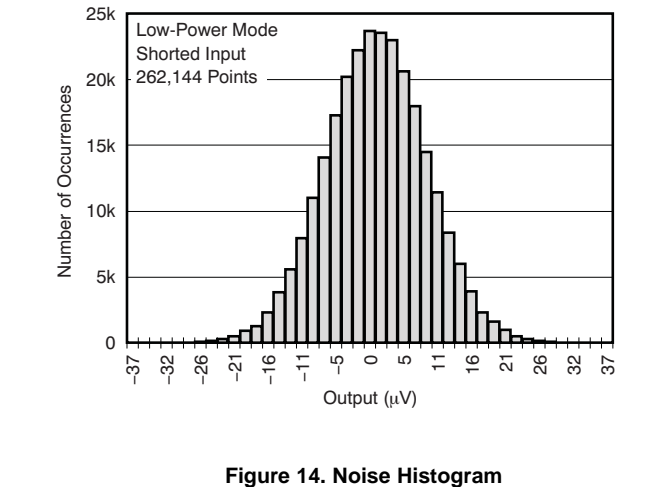

Figure 14. Noise Histogram

Typical Characteristics (continued)

At $T_A = 25^\circ\text{C}$, High-Speed mode, $AV_{DD} = 5\text{ V}$, $DV_{DD} = 1.8\text{ V}$, $IOV_{DD} = 3.3\text{ V}$, $f_{CLK} = 27\text{ MHz}$, $V_{REFP} = 2.5\text{ V}$, and $V_{REFN} = 0\text{ V}$, unless otherwise noted.

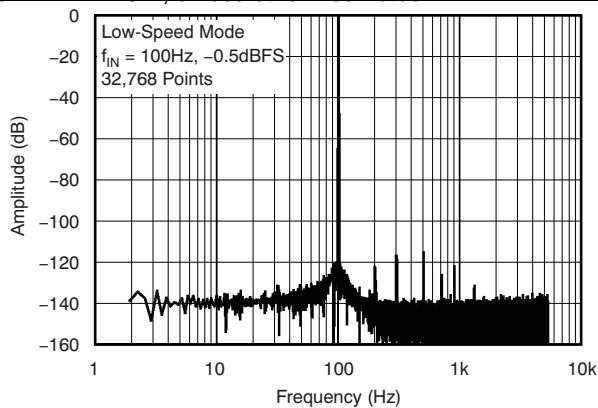

Figure 15. Output Spectrum

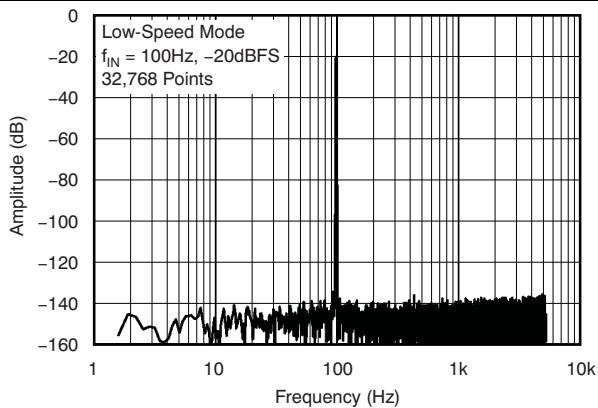

Figure 16. Output Spectrum

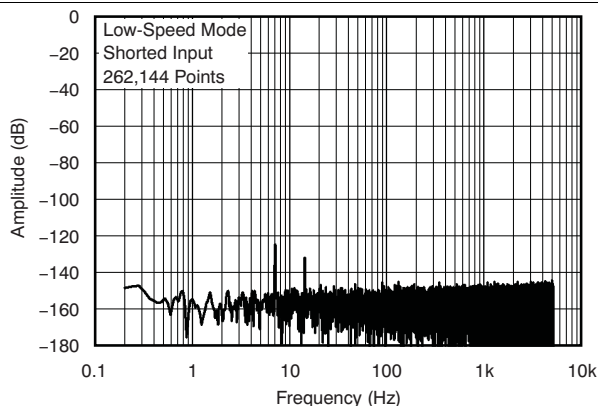

Figure 17. Output Spectrum

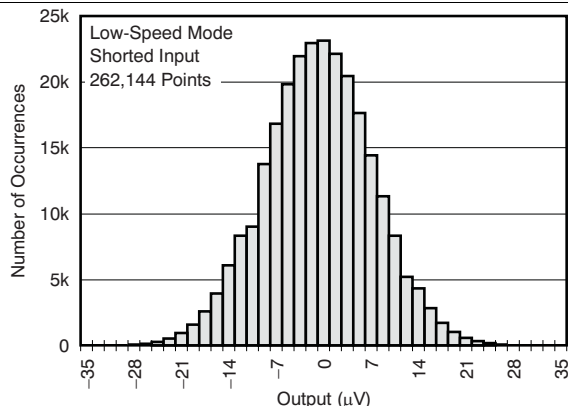

Figure 18. Noise Histogram

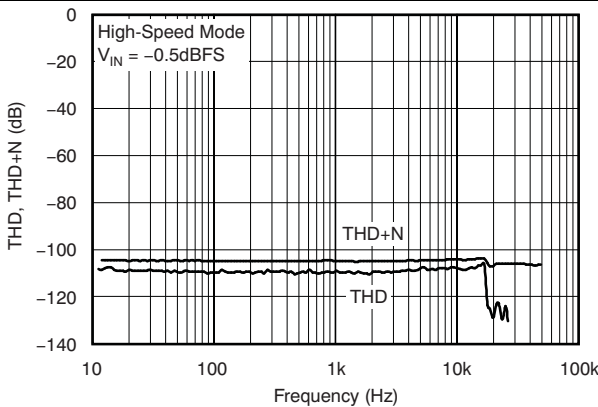

Figure 19. Total Harmonic Distortion vs Frequency

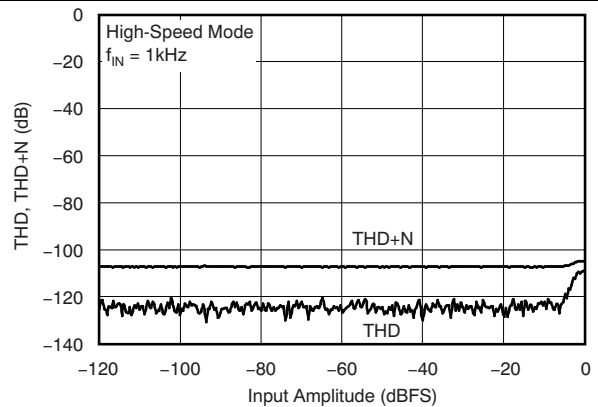

Figure 20. Total Harmonic Distortion vs Input Amplitude

Typical Characteristics (continued)

At $T_A = 25^\circ\text{C}$, High-Speed mode, $AV_{DD} = 5\text{ V}$, $DV_{DD} = 1.8\text{ V}$, $IOV_{DD} = 3.3\text{ V}$, $f_{CLK} = 27\text{ MHz}$, $V_{REFP} = 2.5\text{ V}$, and $V_{REFN} = 0\text{ V}$, unless otherwise noted.

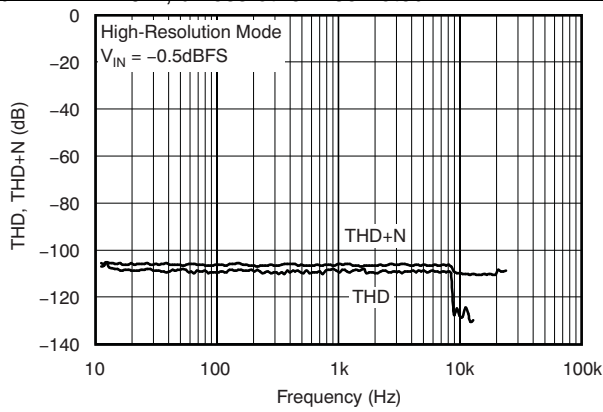

Figure 21. Total Harmonic Distortion vs Frequency

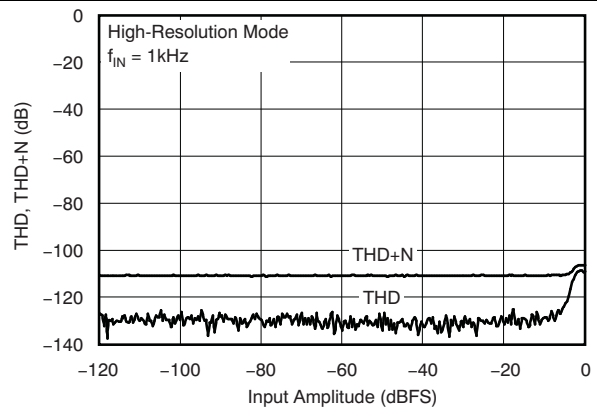

Figure 22. Total Harmonic Distortion vs Input Amplitude

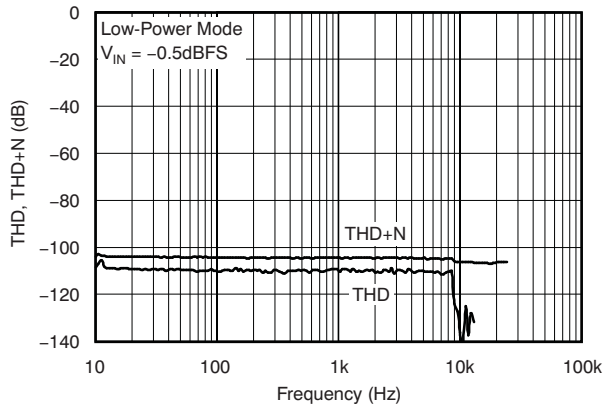

Figure 23. Total Harmonic Distortion vs Frequency

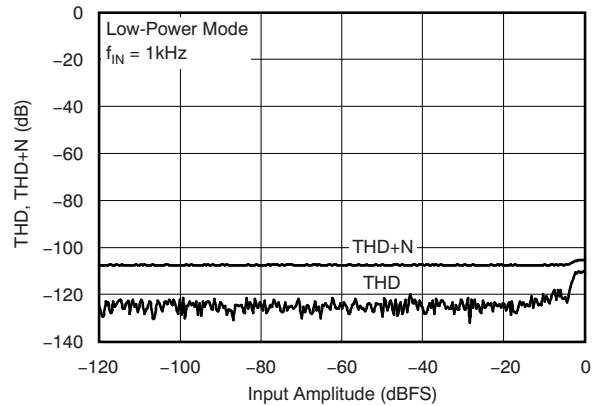

Figure 24. Total Harmonic Distortion vs Input Amplitude

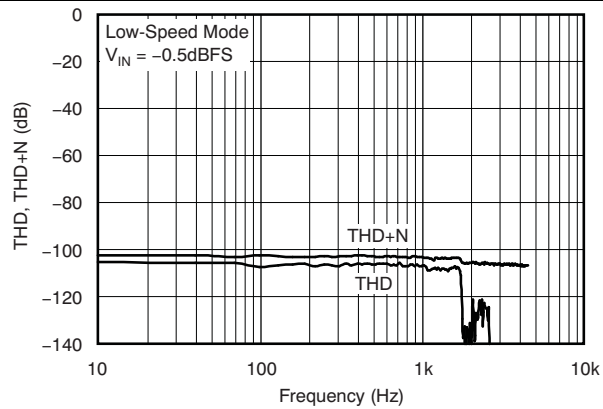

Figure 25. Total Harmonic Distortion vs Frequency

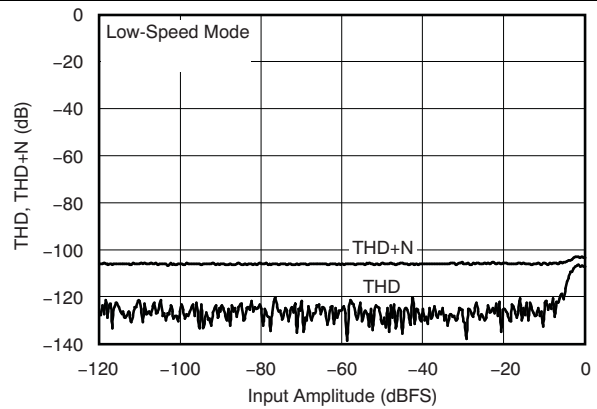

Figure 26. Total Harmonic Distortion vs Input Amplitude

Typical Characteristics (continued)

At $T_A = 25^\circ\text{C}$, High-Speed mode, $AVDD = 5\text{ V}$, $DVDD = 1.8\text{ V}$, $IOVDD = 3.3\text{ V}$, $f_{\text{CLK}} = 27\text{ MHz}$, $V_{\text{REFP}} = 2.5\text{ V}$, and $V_{\text{REFN}} = 0\text{ V}$, unless otherwise noted.

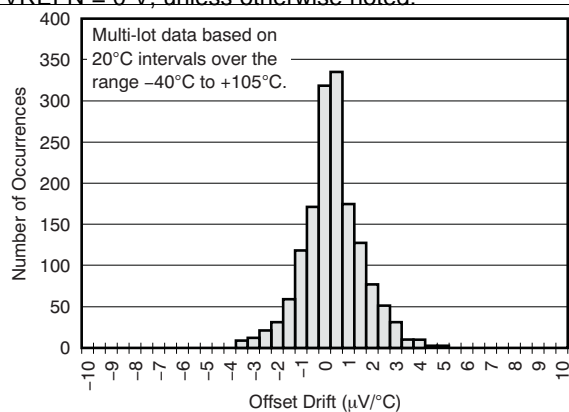

Figure 27. Offset Drift Histogram

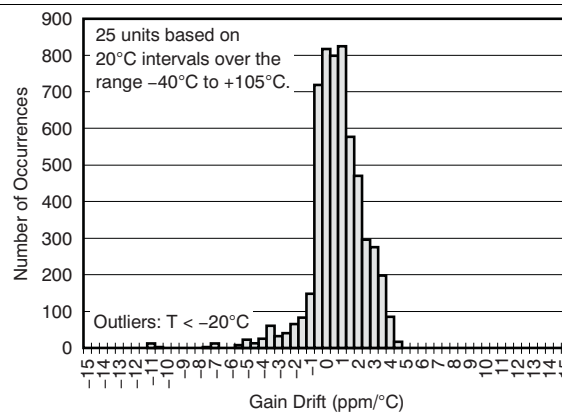

Figure 28. Gain Drift Histogram

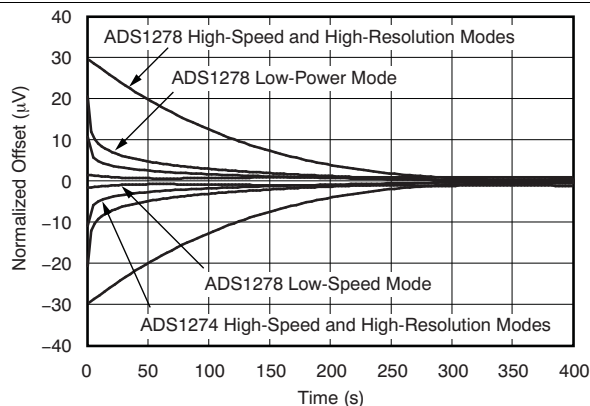

Figure 29. Offset Warmup Drift Response Band

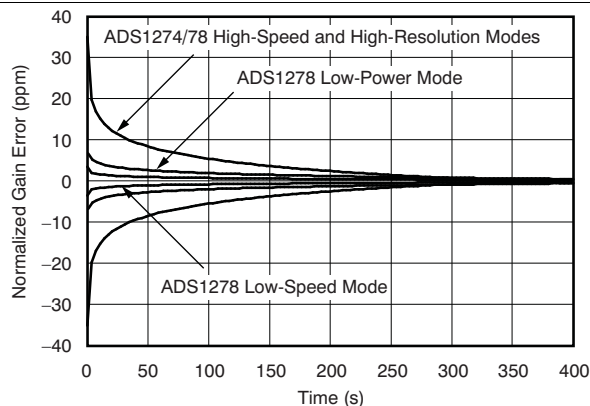

Figure 30. Gain Warmup Drift Response Band

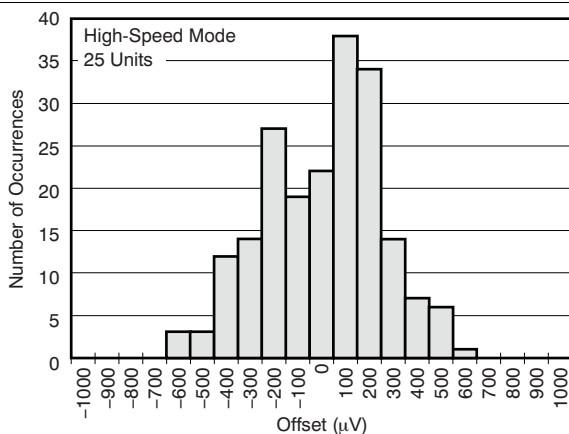

Figure 31. Offset Error Histogram

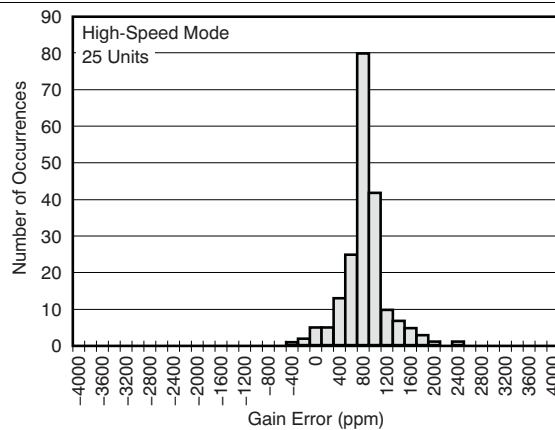

Figure 32. Gain Error Histogram

Typical Characteristics (continued)

At $T_A = 25^\circ\text{C}$, High-Speed mode, $AVDD = 5\text{ V}$, $DVDD = 1.8\text{ V}$, $IOVDD = 3.3\text{ V}$, $f_{\text{CLK}} = 27\text{ MHz}$, $V_{\text{REFP}} = 2.5\text{ V}$, and $V_{\text{REFN}} = 0\text{ V}$, unless otherwise noted.

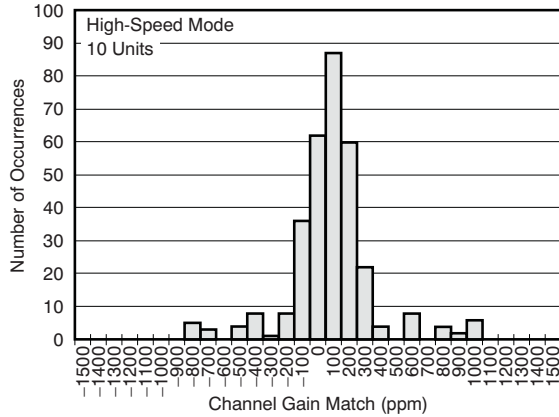

Figure 33. Channel Gain Match Histogram

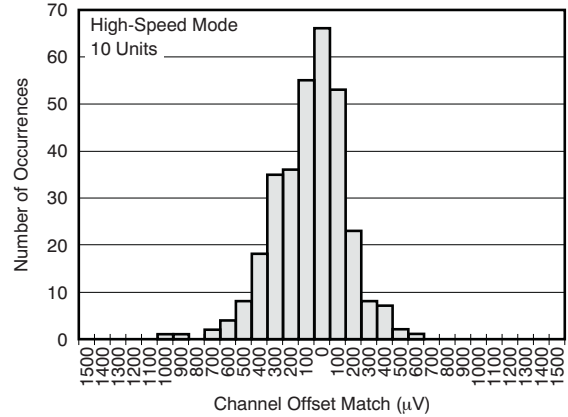

Figure 34. Channel Offset Match Histogram

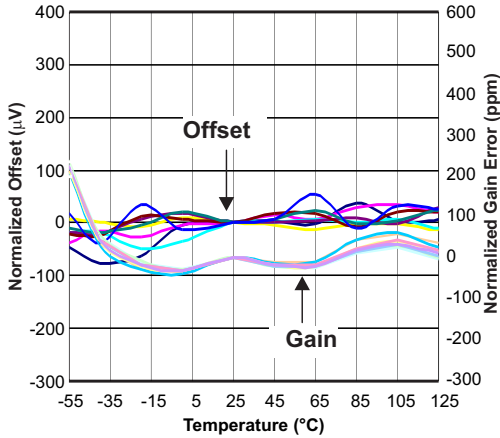

Figure 35. Offset and Gain vs Temperature

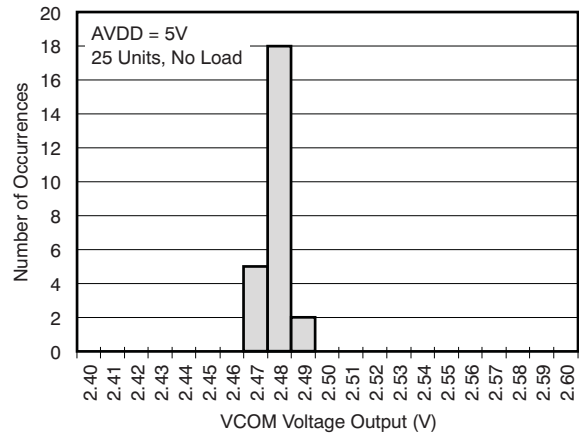

Figure 36. VCOM Voltage Output Histogram

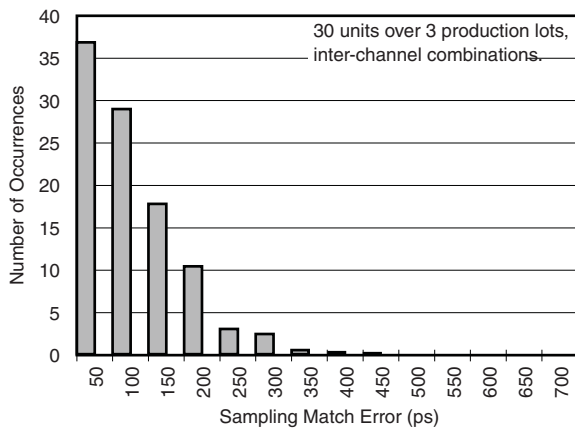

Figure 37. Sampling Match Error Histogram

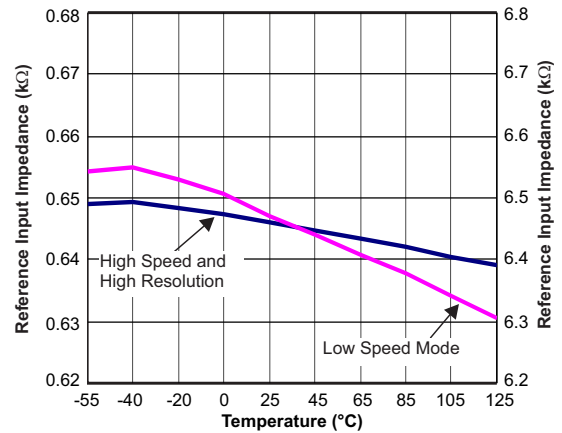

Figure 38. Reference Input Differential Impedance vs Temperature

Typical Characteristics (continued)

At $T_A = 25^\circ\text{C}$, High-Speed mode, $AV_{DD} = 5\text{ V}$, $DV_{DD} = 1.8\text{ V}$, $IOV_{DD} = 3.3\text{ V}$, $f_{CLK} = 27\text{ MHz}$, $V_{REFP} = 2.5\text{ V}$, and $V_{REFN} = 0\text{ V}$, unless otherwise noted.

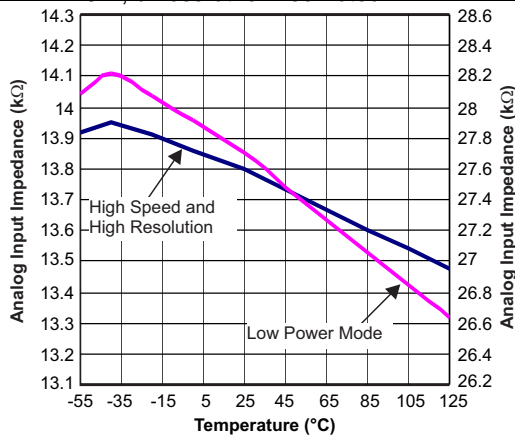

Figure 39. Analog Input Differential Impedance vs Temperature

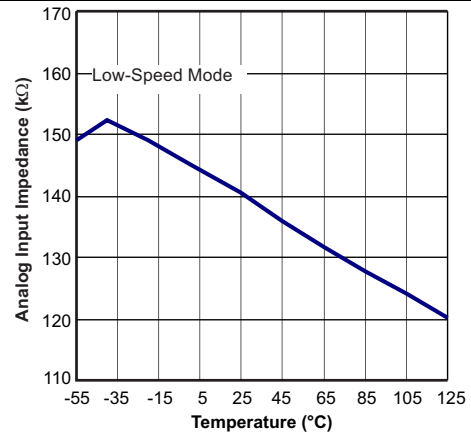

Figure 40. Analog Input Differential Impedance vs Temperature

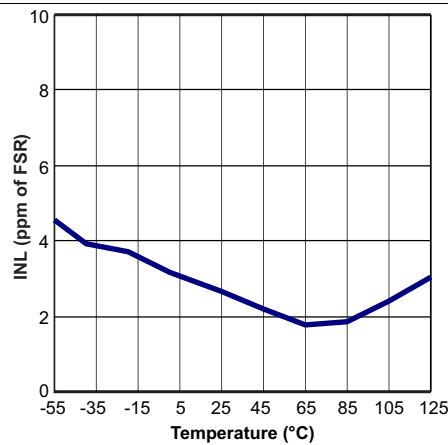

Figure 41. Integral Nonlinearity vs Temperature

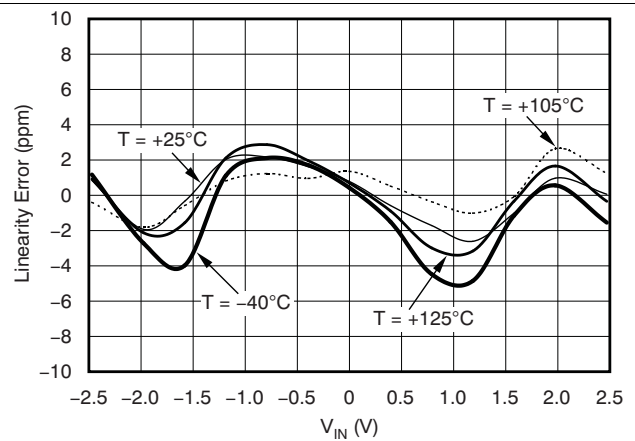

Figure 42. Linearity Error vs Input Level

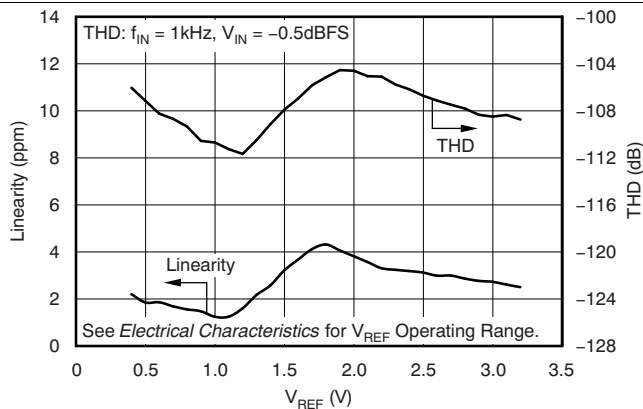

Figure 43. Linearity and Total Harmonic Distortion vs Reference Voltage

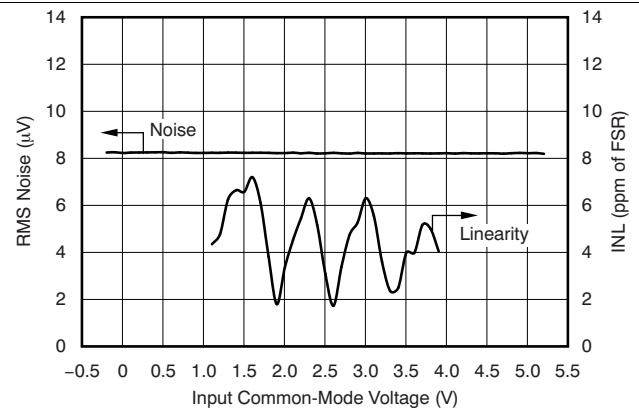

Figure 44. Noise and Linearity vs Input Common-Mode Voltage

Typical Characteristics (continued)

At $T_A = 25^\circ\text{C}$, High-Speed mode, $AVDD = 5\text{ V}$, $DVDD = 1.8\text{ V}$, $IOVDD = 3.3\text{ V}$, $f_{\text{CLK}} = 27\text{ MHz}$, $V_{\text{REFP}} = 2.5\text{ V}$, and $V_{\text{REFN}} = 0\text{ V}$, unless otherwise noted.

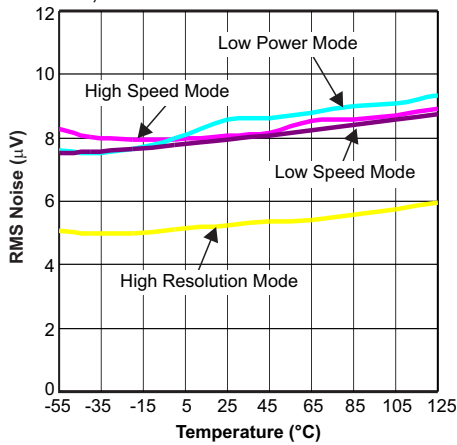

Figure 45. Noise vs Temperature

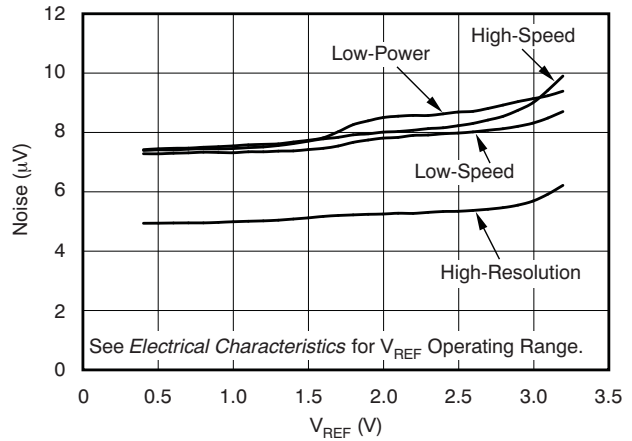

Figure 46. Noise vs Reference Voltage

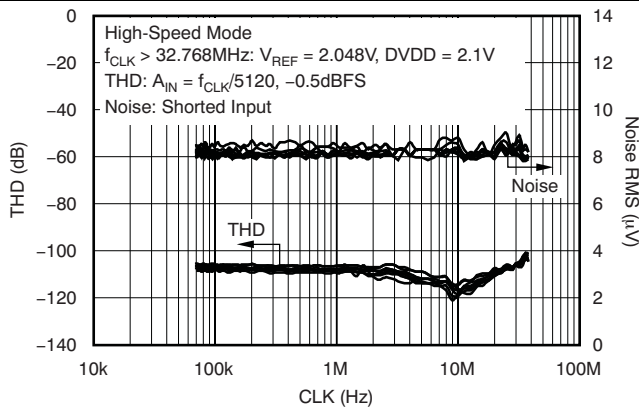

Figure 47. Total Harmonic Distortion and Noise vs CLK

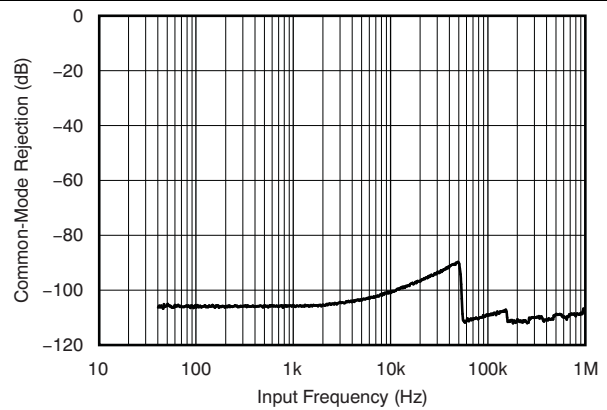

Figure 48. Common-Mode Rejection vs Input Frequency

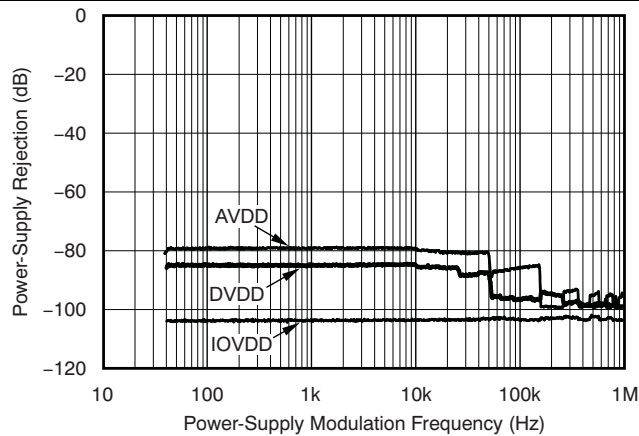

Figure 49. Power-Supply Rejection vs Power-Supply Frequency

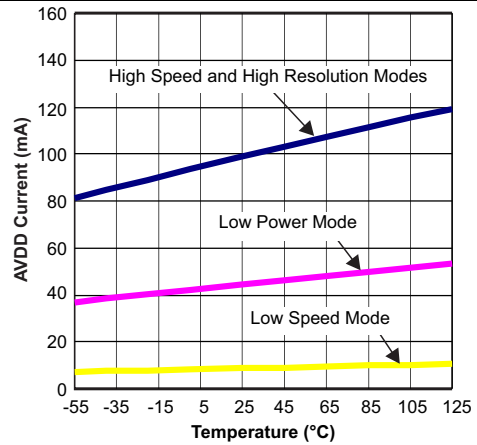

Figure 50. AVDD Current vs Temperature

Typical Characteristics (continued)

At $T_A = 25^\circ\text{C}$, High-Speed mode, $AVDD = 5\text{ V}$, $DVDD = 1.8\text{ V}$, $IOVDD = 3.3\text{ V}$, $f_{CLK} = 27\text{ MHz}$, $VREFP = 2.5\text{ V}$, and $VREFN = 0\text{ V}$, unless otherwise noted.

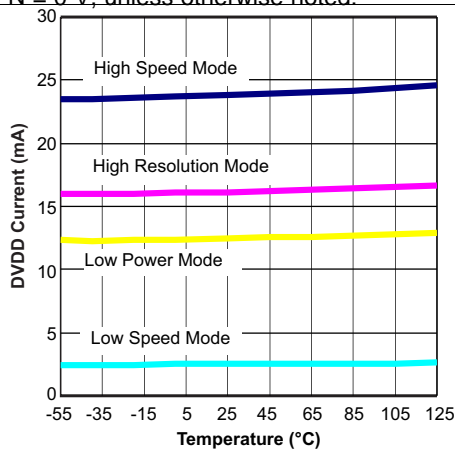

Figure 51. DVDD Current vs Temperature

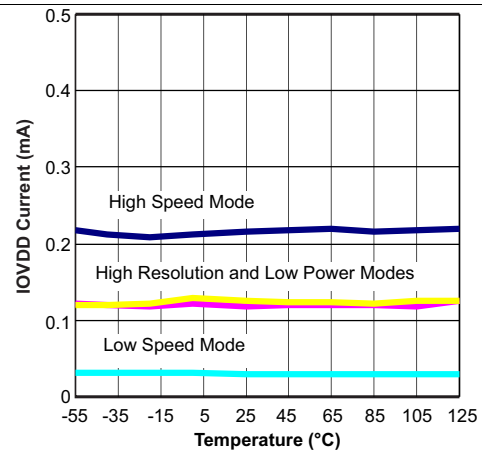

Figure 52. IOVDD Current vs Temperature

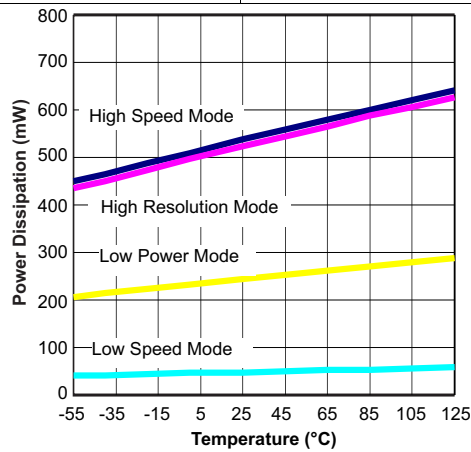

Figure 53. Power Dissipation vs Temperature

8 Detailed Description

8.1 Overview

The ADS1278-SP is a delta-sigma ADC consisting of eight independent converters that digitize eight input signals in parallel.

The converter is composed of two main functional blocks to perform the ADC conversions: the modulator and the digital filter. The modulator samples the input signal together with sampling the reference voltage to produce a 1-s density output stream. The density of the output stream is proportional to the analog input level relative to the reference voltage. The pulse stream is filtered by the internal digital filter where the output conversion result is produced.

In operation, the input signal is sampled by the modulator at a high rate (typically 64x higher than the final output data rate). The quantization noise of the modulator is moved to a higher frequency range where the internal digital filter removes it. Oversampling results in very low levels of noise within the signal passband.

Since the input signal is sampled at a very high rate, input signal aliasing does not occur until the input signal frequency is at the modulator sampling rate. This architecture greatly relaxes the requirement of external antialiasing filters because of the high modulator sampling rate.

The ADS1278-SP is an octal 24-bit, delta-sigma ADC. It offers the combination of outstanding dc accuracy and superior ac performance. [Functional Block Diagram](#) section shows the block diagram. The converter is comprised of eight advanced, 6th-order, chopper-stabilized, delta-sigma modulators followed by low-ripple, linear phase FIR filters. The modulators measure the differential input signal, $V_{IN} = (AINP - AINN)$, against the differential reference, $V_{REF} = (VREFP - VREFN)$. The digital filters receive the modulator signal and provide a low-noise digital output. To allow tradeoffs among speed, resolution, and power, four operating modes are supported:

High-Speed, High-Resolution, Low-Power, and Low-Speed. [Table 15](#) summarizes the performance of each mode.

In High-Speed mode, the maximum data rate is 128 kSPS (when operating at 128 kSPS, Frame-Sync format must be used). In High-Resolution mode, the SNR = 111 dB ($V_{REF} = 3.0$ V); in Low-Power mode, the power dissipation is 31 mW/channel; and in Low-Speed mode, the power dissipation is only 7 mW/channel at 10.5 kSPS. The digital filters can be bypassed, enabling direct access to the modulator output.

The ADS1278-SP is configured by simply setting the appropriate I/O pins—there are no registers to program. Data are retrieved over a serial interface that supports both SPI and Frame-Sync formats. The ADS1278-SP has a daisy-chainable output and the ability to synchronize externally, so it can be used conveniently in systems requiring more than eight channels.

8.2 Functional Block Diagram

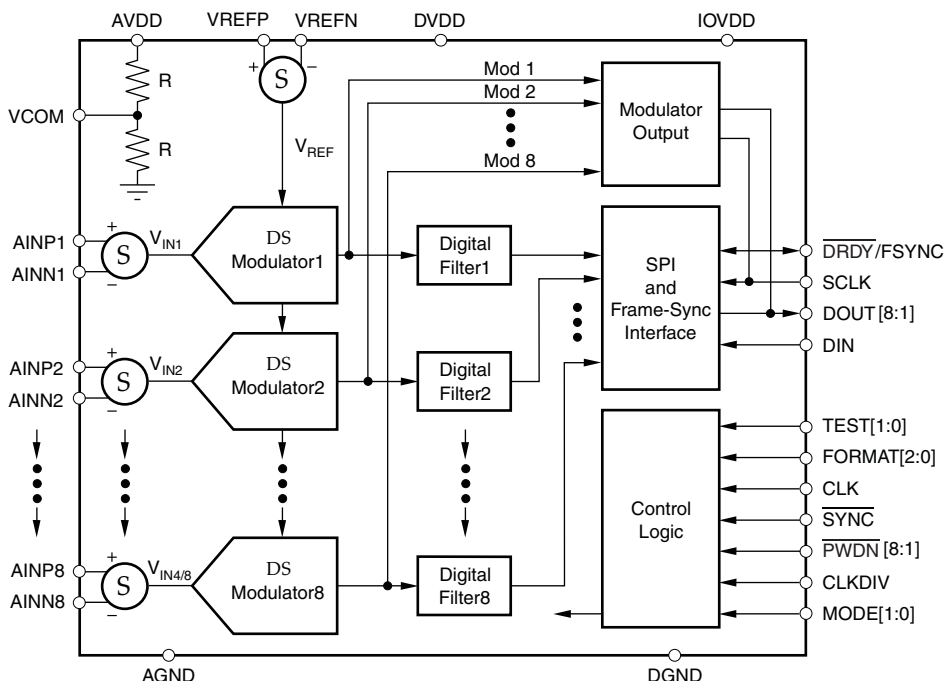

8.3 Feature Description

8.3.1 Sampling Aperture Matching

The ADS1278-SP converter operates from the same CLK input. The CLK input controls the timing of the modulator sampling instant. The converter is designed such that the sampling skew, or modulator sampling aperture match between channels, is controlled. Furthermore, the digital filters are synchronized to start the convolution phase at the same modulator clock cycle. This design results in excellent phase match among the ADS1278-SP channels.

Figure 37 shows the inter-device channel sample matching for the ADS1278-SP.

8.3.2 Frequency Response

The digital filter sets the overall frequency response. The filter uses a multi-stage FIR topology to provide linear phase with minimal passband ripple and high stop band attenuation. The filter coefficients are identical to the coefficients used in the ADS1271. The oversampling ratio of the digital filter (that is, the ratio of the modulator sampling to the output data rate, or f_{MOD}/f_{DATA}) is a function of the selected mode, as shown in Table 1.

Table 1. Oversampling Ratio vs Mode

MODE SELECTION	OVERSAMPLING RATIO (f_{MOD}/f_{DATA})
High-Speed	64
High-Resolution	128
Low-Power	64
Low-Speed	64

8.3.2.1 High-Speed, Low-Power, And Low-Speed Modes

The digital filter configuration is the same in High-Speed, Low-Power, and Low-Speed modes with the oversampling ratio set to 64. Figure 54 shows the frequency response in High-Speed, Low-Power, and Low-Speed modes normalized to f_{DATA} . Figure 55 shows the passband ripple. The transition from passband to stop band is shown in Figure 56. The overall frequency response repeats at 64x multiples of the modulator frequency f_{MOD} , as shown in Figure 57.

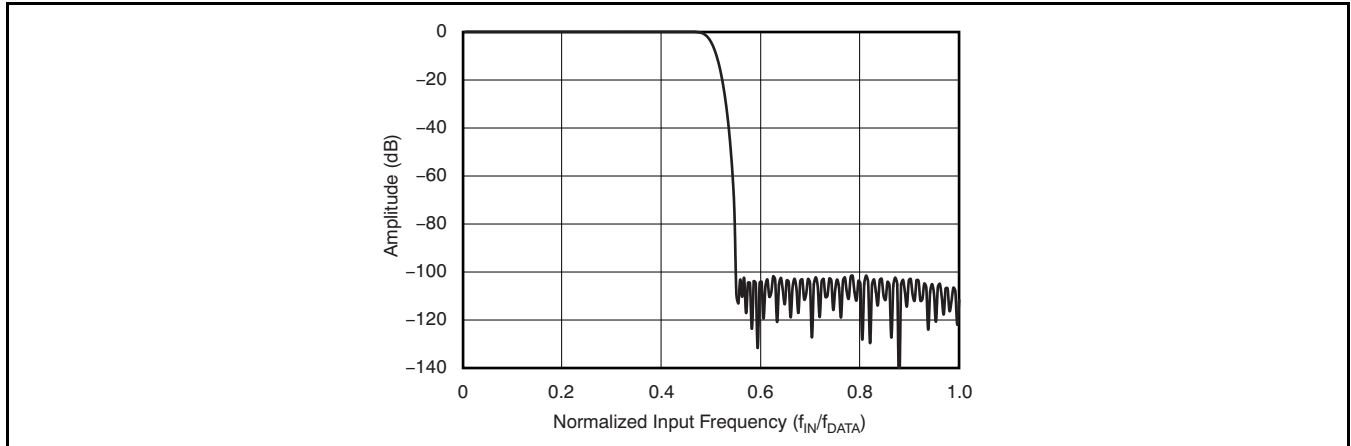

Figure 54. Frequency Response For High-Speed, Low-Power, And Low-Speed Modes

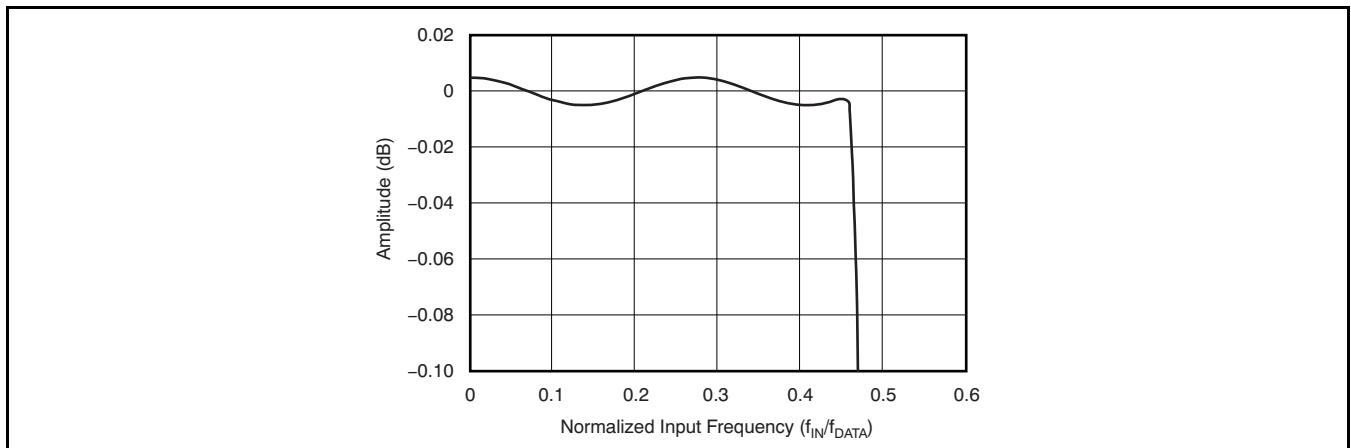

Figure 55. Passband Response For High-Speed, Low-Power, And Low-Speed Modes

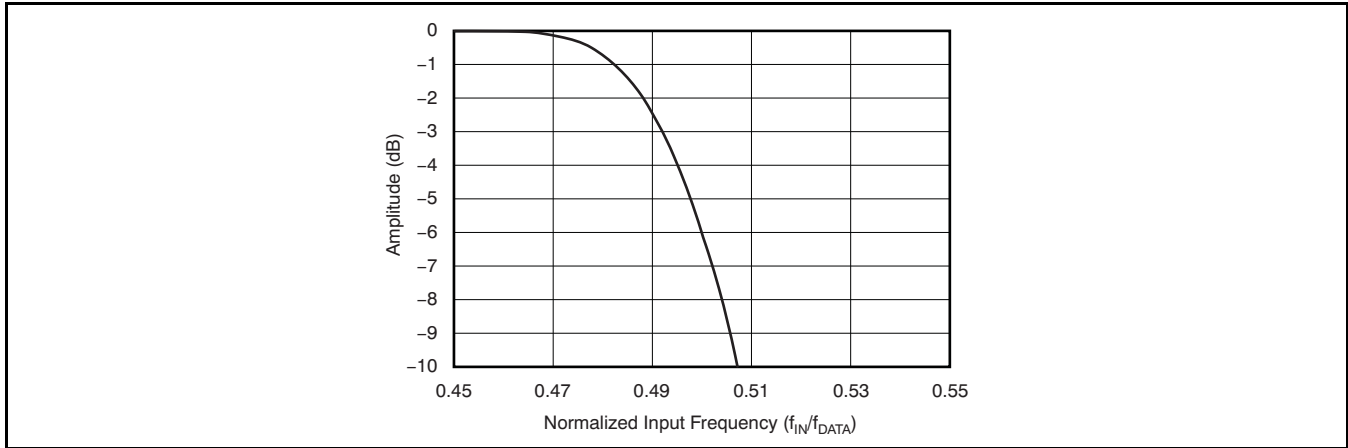

Figure 56. Transition Band Response For High-Speed, Low-Power, and Low-Speed Modes

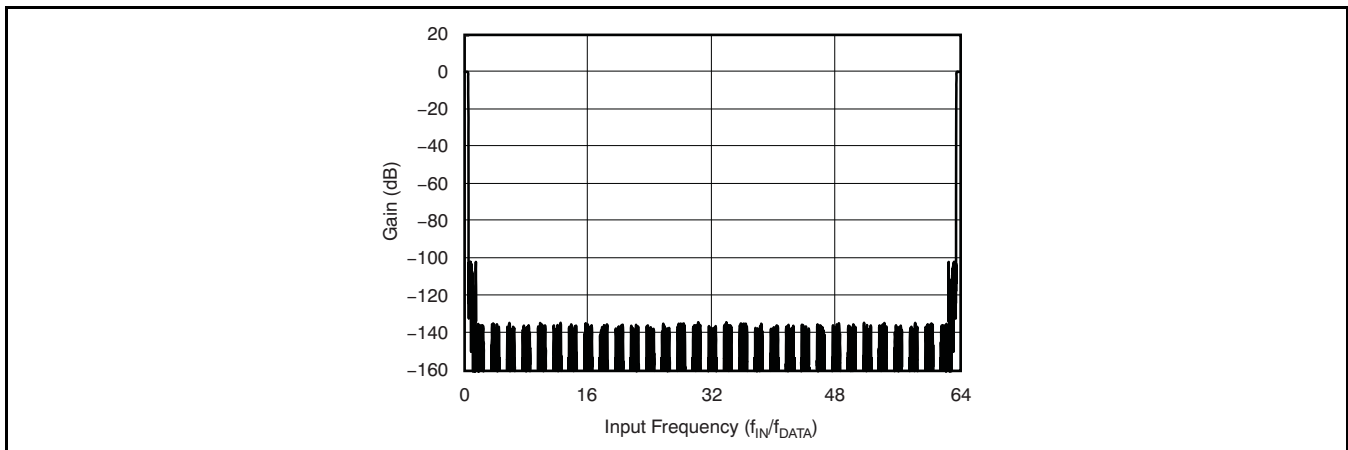

Figure 57. Frequency Response Out To F_{MOD} For High-Speed, Low-Power, And Low-Speed Modes

These image frequencies, if present in the signal and not externally filtered, will fold back (or alias) into the passband, causing errors. The stop band of the ADS1278-SP provides 100-dB attenuation of frequencies that begin just beyond the passband and continue out to f_{MOD} . Placing an anti-aliasing, low-pass filter in front of the ADS1278-SP inputs is recommended to limit possible high-amplitude, out-of-band signals and noise. Often, a simple RC filter is sufficient. Table 2 lists the image rejection versus external filter order.

Table 2. Antialiasing Filter Order Image Rejection

ANTIALIASING FILTER ORDER	IMAGE REJECTION (dB) (f_{-3dB} at f_{DATA})	
	HS, LP, LS	HR
1	39	45
2	75	87
3	111	129

8.3.2.2 High-Resolution Mode

The oversampling ratio is 128 in High-Resolution mode. [Figure 58](#) shows the frequency response in High-Resolution mode normalized to f_{DATA} . [Figure 59](#) shows the passband ripple, and the transition from passband to stop band is shown in [Figure 60](#). The overall frequency response repeats at multiples of the modulator frequency f_{MOD} ($128 \times f_{DATA}$), as shown in [Figure 61](#). The stop band of the ADS1278-SP provides 100-dB attenuation of frequencies that begin just beyond the passband and continue out to f_{MOD} . Placing an antialiasing, low-pass filter in front of the ADS1278-SP inputs is recommended to limit possible high-amplitude out-of-band signals and noise. Often, a simple RC filter is sufficient. [Table 2](#) lists the image rejection versus external filter order.

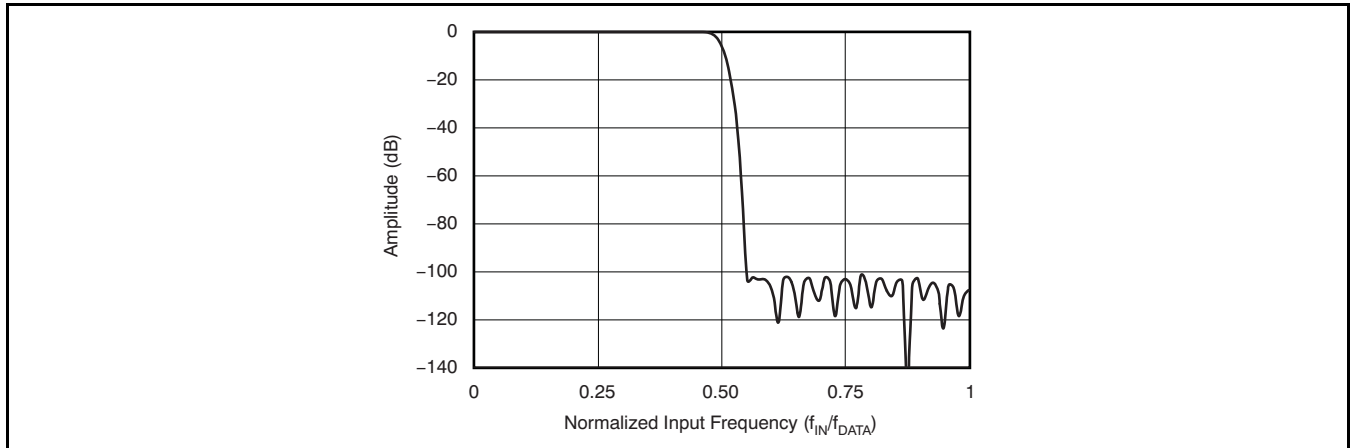

Figure 58. Frequency Response For High-Resolution Mode

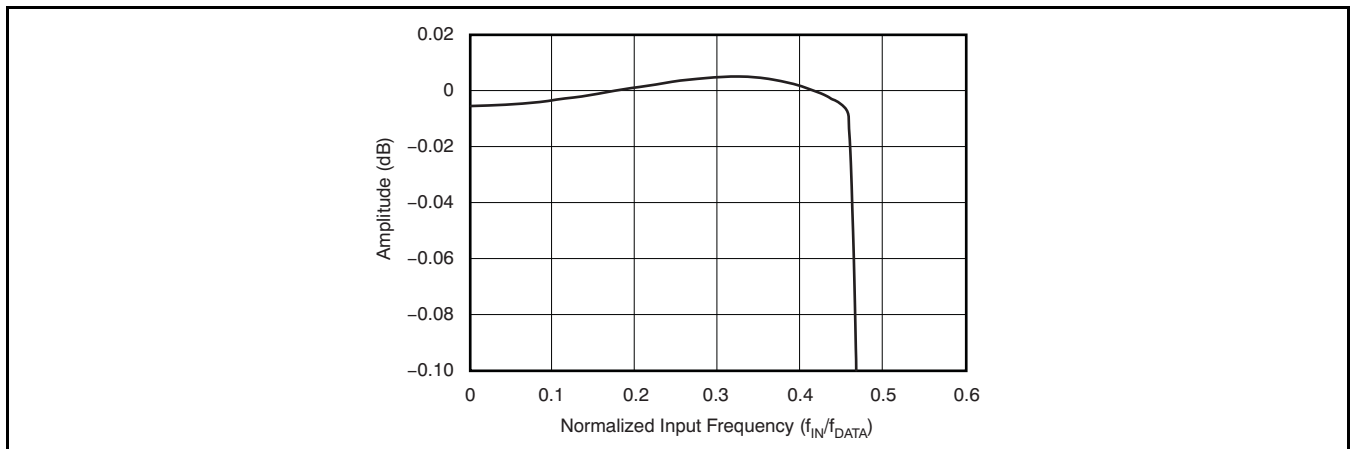

Figure 59. Passband Response For High-Resolution Mode

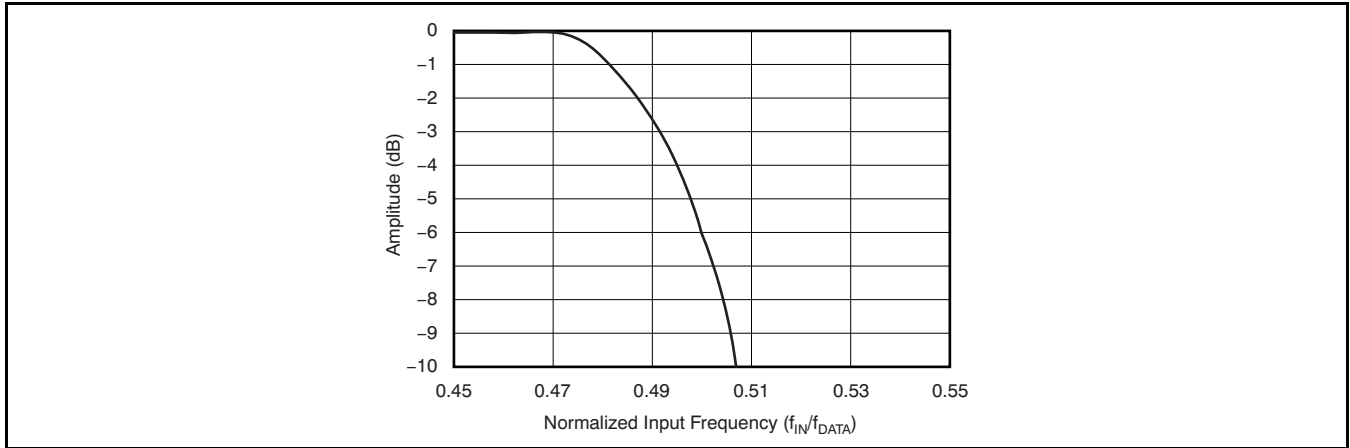

Figure 60. Transition Band Response For High-Resolution Mode

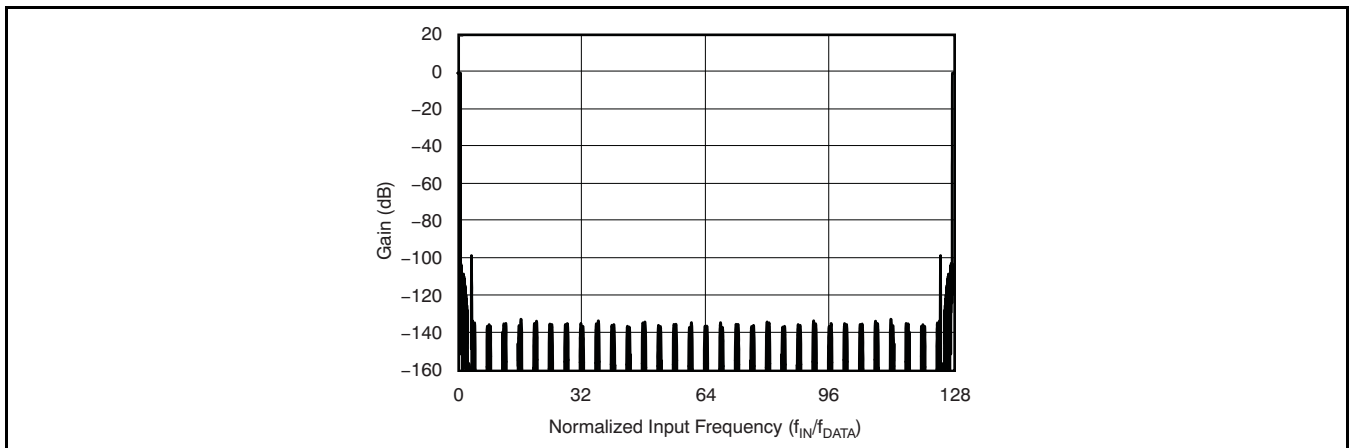

Figure 61. Frequency Response Out To F_{MOD} For High-Resolution Mode

8.3.3 Phase Response

The ADS1278-SP incorporates a multiple stage, linear phase digital filter. Linear phase filters exhibit constant delay time versus input frequency (constant group delay). This characteristic means the time delay from any instant of the input signal to the same instant of the output data is constant and is independent of input signal frequency. This behavior results in essentially zero phase errors when analyzing multi-tone signals.

8.3.4 Settling Time

As with frequency and phase response, the digital filter also determines settling time. Figure 62 shows the output settling behavior after a step change on the analog inputs normalized to conversion periods. The X-axis is given in units of conversion. Note that after the step change on the input occurs, the output data change very little prior to 30 conversion periods. The output data are fully settled after 76 conversion periods for High-Speed and Low-Power modes, and 78 conversion periods for High-Resolution mode.

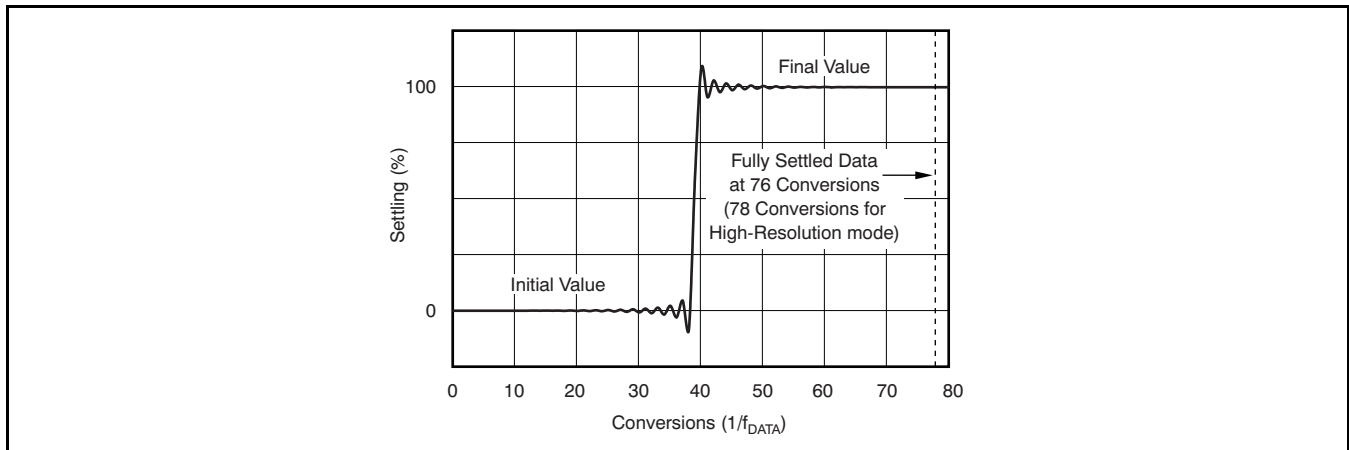

Figure 62. Step Response

8.3.5 Data Format

The ADS1278-SP outputs 24 bits of data in twos complement format.

A positive full-scale input produces an ideal output code of 7FFFFFFh, and the negative full-scale input produces an ideal output code of 800000h. The output clips at these codes for signals exceeding full-scale. Table 3 summarizes the ideal output codes for different input signals.

Table 3. Ideal Output Code Versus Input Signal

INPUT SIGNAL V_{IN} ($A_{INP} - A_{INN}$)	IDEAL OUTPUT CODE ⁽¹⁾
$\geq +V_{REF}$	7FFFFFFh
$\frac{+V_{REF}}{2^{23} - 1}$	000001h
0	000000h
$\frac{-V_{REF}}{2^{23} - 1}$	FFFFFFh
$\leq -V_{REF} \left(\frac{2^{23}}{2^{23} - 1} \right)$	800000h

(1) Excludes effects of noise, INL, offset, and gain errors.

8.3.6 Analog Inputs (AINP, AINN)

The ADS1278-SP measures each differential input signal $V_{IN} = (AINP - AINN)$ against the common differential reference $V_{REF} = (VREFP - VREFN)$. The most positive measurable differential input is $+V_{REF}$, which produces the most positive digital output code of 7FFFFFFh. Likewise, the most negative measurable differential input is $-V_{REF}$, which produces the most negative digital output code of 800000h.

For optimum performance, the inputs of the ADS1278-SP are intended to be driven differentially. For single-ended applications, one of the inputs (AINP or AINN) can be driven while the other input is fixed (typically to AGND or 2.5 V). Fixing the input to 2.5 V permits bipolar operation, thereby allowing full use of the entire converter range.

While the ADS1278-SP measures the differential input signal, the absolute input voltage is also important. This value is the voltage on either input (AINP or AINN) with respect to AGND. The range for this voltage is:

$$-0.1 \text{ V} < (AINN \text{ or } AINP) < AVDD + 0.1 \text{ V}$$

If either input is taken below -0.4 V or above $(AVDD + 0.4 \text{ V})$, ESD protection diodes on the inputs may turn on. If these conditions are possible, external Schottky clamp diodes or series resistors may be required to limit the input current to safe values (see the [Absolute Maximum Ratings](#) table).

The ADS1278-SP is a very high-performance ADC. For optimum performance, it is critical that the appropriate circuitry be used to drive the ADS1278-SP inputs. See the [Application Information](#) section for several recommended circuits.

The ADS1278-SP uses switched-capacitor circuitry to measure the input voltage. Internal capacitors are charged by the inputs and then discharged. Figure 63 shows a conceptual diagram of these circuits. Switch S_2 represents the net effect of the modulator circuitry in discharging the sampling capacitor; the actual implementation is different. The timing for switches S_1 and S_2 is shown in Figure 64. The sampling time (t_{SAMPLE}) is the inverse of modulator sampling frequency (f_{MOD}) and is a function of the mode, the CLKDIV input, and CLK frequency, as shown in Table 4.

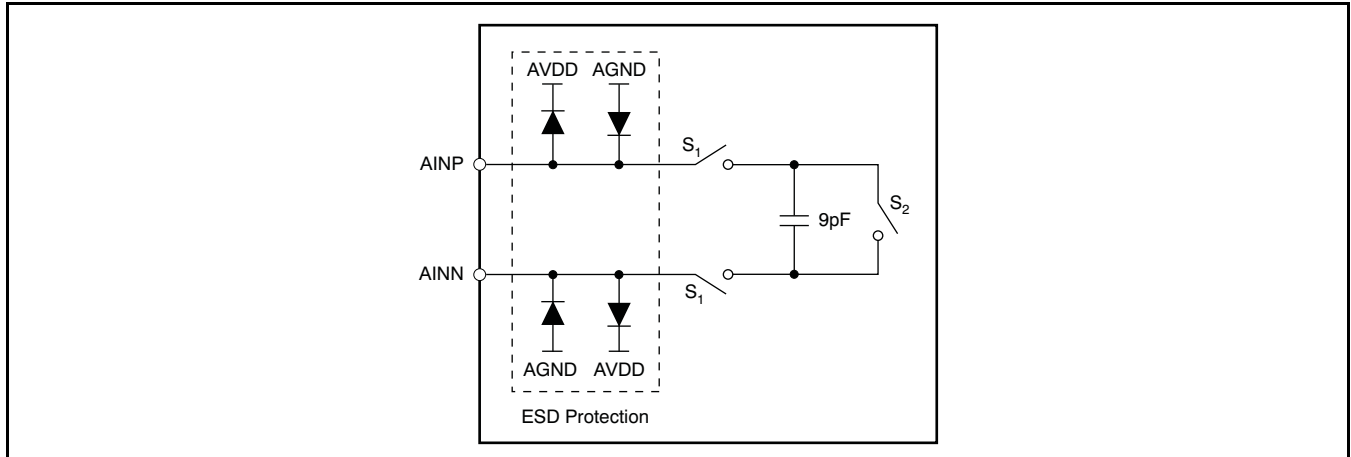

Figure 63. Equivalent Analog Input Circuitry

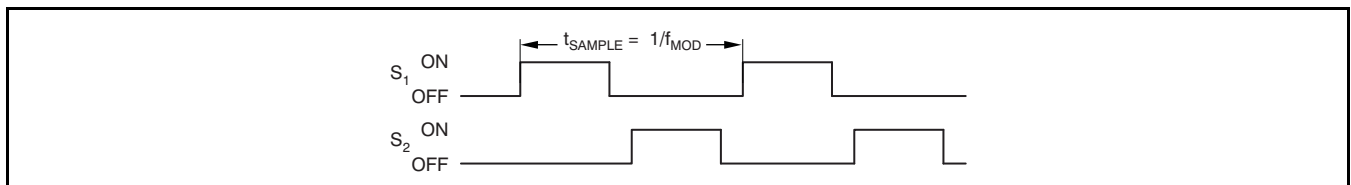

Figure 64. S_1 and S_2 Switch Timing for Figure 63

Table 4. Modulator Frequency (F_{MOD}) Mode Selection

MODE SELECTION	CLKDIV	f_{MOD}
High-Speed	1	$f_{CLK} / 4$
High-Resolution	1	$f_{CLK} / 4$
Low-Power	1	$f_{CLK} / 8$
	0	$f_{CLK} / 4$
Low-Speed	1	$f_{CLK} / 40$
	0	$f_{CLK} / 8$

The average load presented by the switched capacitor input can be modeled with an effective differential impedance, as shown in Figure 65. Note that the effective impedance is a function of f_{MOD} .

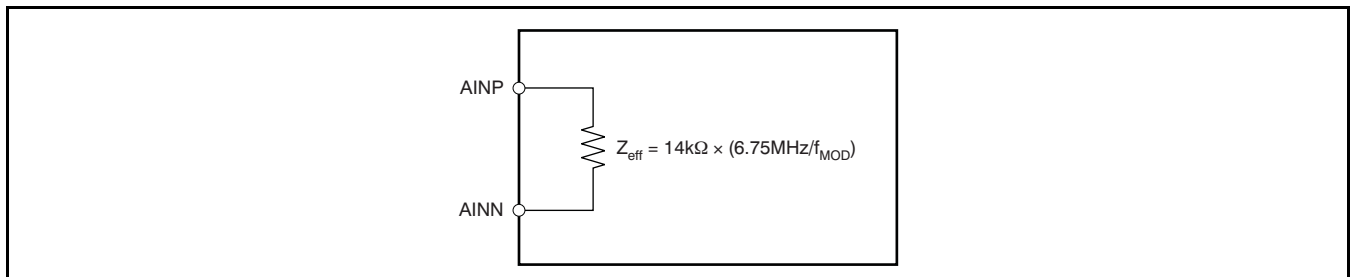

Figure 65. Effective Input Impedances

8.3.7 Voltage Reference Inputs (VREFP, VREFN)

The voltage reference for the ADS1278-SP ADC is the differential voltage between VREFP and VREFN: $V_{REF} = (VREFP - VREFN)$. The voltage reference is common to all channels. The reference inputs use a structure similar to that of the analog inputs with the equivalent circuitry on the reference inputs shown in Figure 66. As with the analog inputs, the load presented by the switched capacitor can be modeled with an effective impedance, as shown in Figure 67. However, the reference input impedance depends on the number of active (enabled) channels in addition to f_{MOD} . As a result of the change of reference input impedance caused by enabling and disabling channels, the regulation and setting time of the external reference should be noted, so as not to affect the readings.

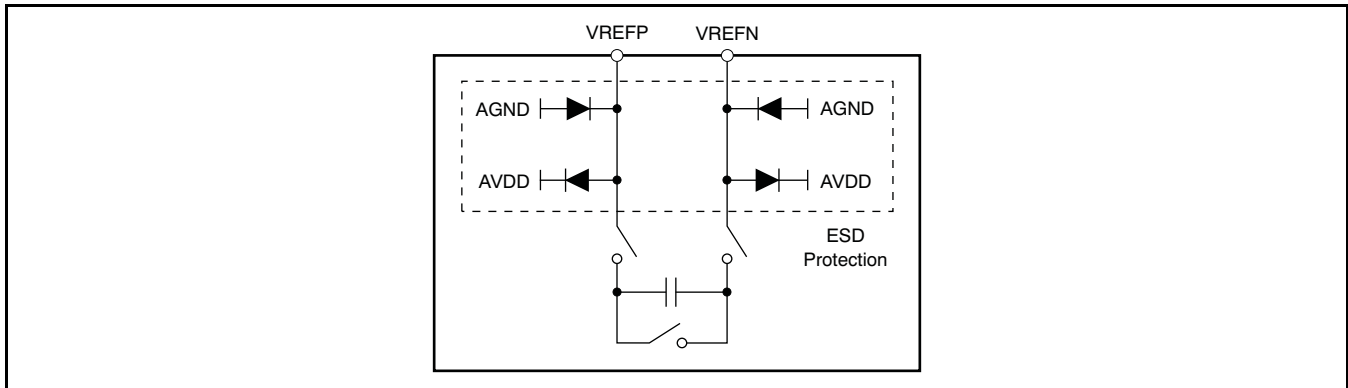

Figure 66. Equivalent Reference Input Circuitry

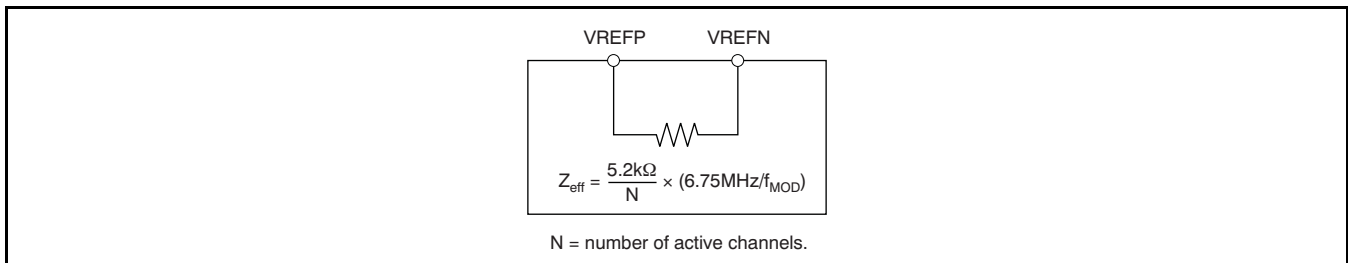

Figure 67. Effective Reference Impedance

ESD diodes protect the reference inputs. To keep these diodes from turning on, make sure the voltages on the reference pins do not go below AGND by more than 0.4 V, and likewise do not exceed AVDD by 0.4 V. If these conditions are possible, external Schottky clamp diodes or series resistors may be required to limit the input current to safe values (see the [Absolute Maximum Ratings](#) table).

Note that the valid operating range of the reference inputs is limited to the following parameters:

$$-0.1 \text{ V} \leq VREFN \leq +0.1 \text{ V}$$

$$VREFN + 0.5 \text{ V} \leq VREFP \leq AVDD + 0.1 \text{ V}$$

8.3.8 Clock Input (CLK)

The ADS1278-SP requires a clock input for operation. The individual converters of the ADS1278-SP operate from the same clock input. At the maximum data rate, the clock input can be either 27 MHz or 13.5 MHz for Low-Power mode, or 27MHz or 5.4 MHz for Low-Speed mode, determined by the setting of the CLKDIV input. For High-Speed mode, the maximum CLK input frequency is 32.768 MHz. For High-Resolution mode, the maximum CLK input frequency is 27 MHz. The selection of the external clock frequency (f_{CLK}) does not affect the resolution of the ADS1278-SP. Use of a slower f_{CLK} can reduce the power consumption of an external clock buffer. The output data rate scales with clock frequency, down to a minimum clock frequency of $f_{CLK} = 100 \text{ kHz}$. Table 5 summarizes the ratio of the clock input frequency (f_{CLK}) to data rate (f_{DATA}), maximum data rate and corresponding maximum clock input for the four operating modes.

As with any high-speed data converter, a high-quality, low-jitter clock is essential for optimum performance. Crystal clock oscillators are the recommended clock source. Make sure to avoid excess ringing on the clock input; keeping the clock trace as short as possible, and using a 50-Ω series resistor placed close to the source end, often helps.

Table 5. Clock Input Options

MODE SELECTION	MAX f_{CLK} (MHz)	CLKDIV	f_{CLK}/f_{DATA}	DATA RATE (SPS)
High-Speed	32.768	1	256	128,000
High-Resolution	27	1	512	52,734
Low-Power	27	1	512	52,734
	13.5	0	256	
Low-Speed	27	1	2,560	10,547
	5.4	0	512	

8.3.9 Mode Selection (MODE)

The ADS1278-SP supports four modes of operation: High-Speed, High-Resolution, Low-Power, and Low-Speed. The modes offer optimization of speed, resolution, and power. Mode selection is determined by the status of the digital input MODE[1:0] pins, as shown in [Table 6](#). The ADS1278-SP continually monitors the status of the MODE pin during operation.

Table 6. Mode Selection

MODE[1:0]	MODE SELECTION	MAX f_{DATA} ⁽¹⁾
00	High-Speed	128,000
01	High-Resolution	52,734
10	Low-Power	52,734
11	Low-Speed	10,547

(1) f_{CLK} = 27-MHz max (32.768-MHz max in High-Speed mode).

When using the SPI protocol, \overline{DRDY} is held high after a mode change occurs until settled (or valid) data are ready; see [Figure 68](#) and [Table 7](#).

In Frame-Sync protocol, the DOUT pins are held low after a mode change occurs until settled data are ready; see [Figure 68](#) and [Table 7](#). Data can be read from the device to detect when DOUT changes to logic 1, indicating that the data are valid.

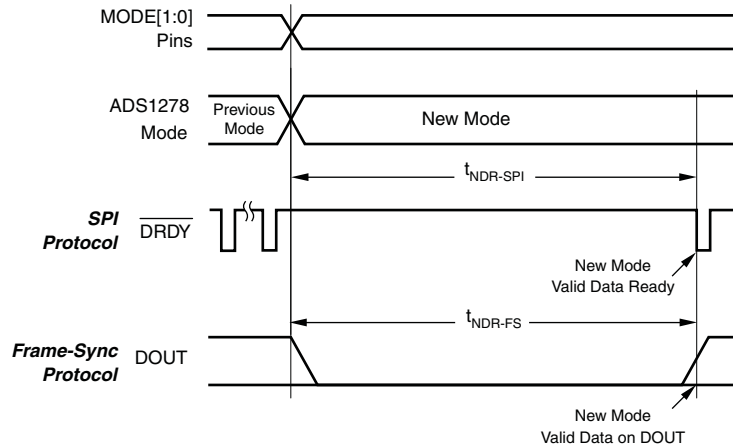

Figure 68. Mode Change Timing

Table 7. New Data After Mode Change

SYMBOL	DESCRIPTION	MIN	TYP	MAX	UNITS
$t_{\text{NDR-SPI}}$	Time for new data to be ready (SPI)			129	Conversions ($1/f_{\text{DATA}}$)
$t_{\text{NDR-FS}}$	Time for new data to be ready (Frame-Sync)	127		128	Conversions ($1/f_{\text{DATA}}$)

8.3.10 Synchronization ($\overline{\text{SYNC}}$)

The ADS1278-SP can be synchronized by pulsing the $\overline{\text{SYNC}}$ pin low and then returning the pin high. When the pin goes low, the conversion process stops, and the internal counters used by the digital filter are reset. When the $\overline{\text{SYNC}}$ pin returns high, the conversion process restarts. Synchronization allows the conversion to be aligned with an external event, such as the changing of an external multiplexer on the analog inputs, or by a reference timing pulse.

Because the ADS1278-SP converters operate in parallel from the same master clock and use the same $\overline{\text{SYNC}}$ input control, they are always in synchronization with each other. The aperture match among internal channels is typically less than 500 ps. However, the synchronization of multiple devices is somewhat different. At device power-on, variations in internal reset thresholds from device to device may result in uncertainty in conversion timing.

The $\overline{\text{SYNC}}$ pin can be used to synchronize multiple devices to within the same CLK cycle. Figure 69 illustrates the timing requirement of $\overline{\text{SYNC}}$ and CLK in SPI format.

See Figure 70 for the Frame-Sync format timing requirement.

After synchronization, indication of valid data depends on whether SPI or Frame-Sync format was used.

In the SPI format, $\overline{\text{DRDY}}$ goes high as soon as $\overline{\text{SYNC}}$ is taken low; see Figure 69. After $\overline{\text{SYNC}}$ is returned high, $\overline{\text{DRDY}}$ stays high while the digital filter is settling. Once valid data are ready for retrieval, $\overline{\text{DRDY}}$ goes low.

In the Frame-Sync format, DOUT goes low as soon as $\overline{\text{SYNC}}$ is taken low; see Figure 70. After $\overline{\text{SYNC}}$ is returned high, DOUT stays low while the digital filter is settling. Once valid data are ready for retrieval, DOUT begins to output valid data. For proper synchronization, FSYNC, SCLK, and CLK must be established before taking $\overline{\text{SYNC}}$ high, and must then remain running. If the clock inputs (CLK, FSYNC or SCLK) are subsequently interrupted or reset, re-assert the $\overline{\text{SYNC}}$ pin.

For consistent performance, re-assert $\overline{\text{SYNC}}$ after device power-on when data first appear.

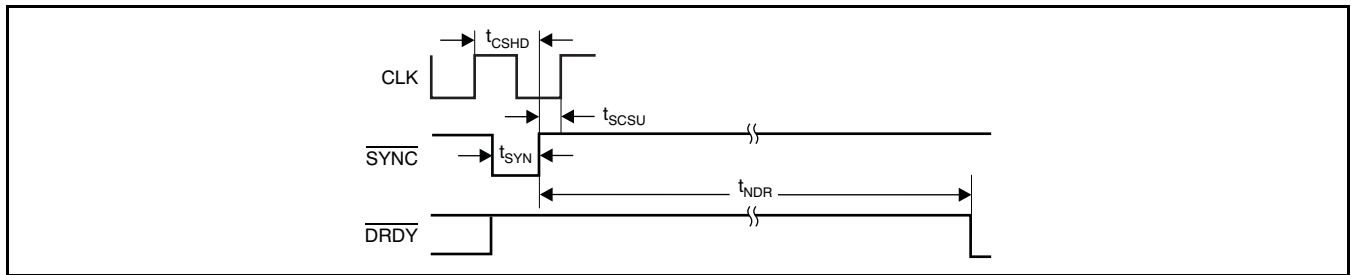

Figure 69. Synchronization Timing (SPI Protocol)

Table 8. SPI Protocol

SYMBOL	DESCRIPTION	MIN	TYP	MAX	UNITS
t_{CSHD}	CLK to \overline{SYNC} hold time	10			ns
t_{SCSU}	\overline{SYNC} to CLK setup time	5			ns
t_{SYN}	Synchronize pulse width	1			CLK periods
t_{NDR}	Time for new data to be ready			129	Conversions ($1/f_{DATA}$)

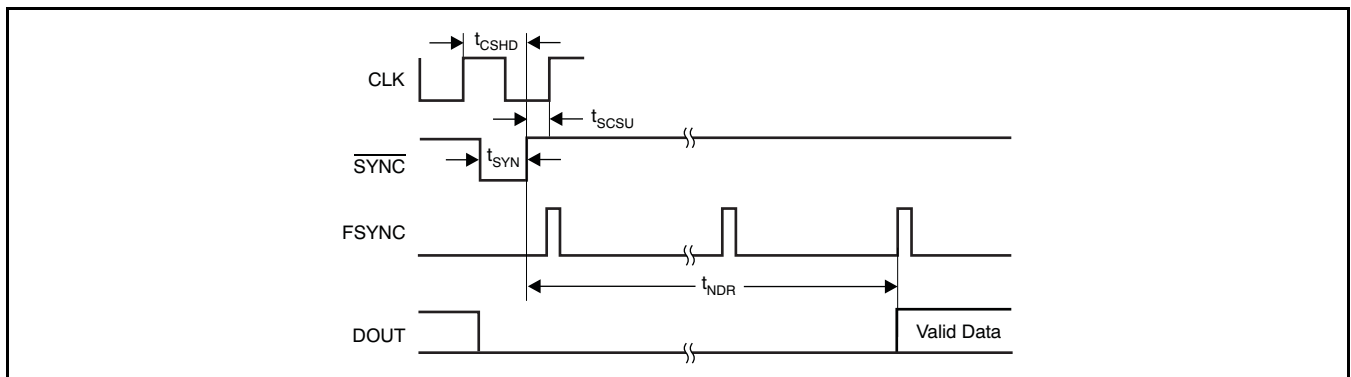

Figure 70. Synchronization Timing (Frame-Sync Protocol)

Table 9. Frame-Sync Protocol

SYMBOL	DESCRIPTION	MIN	TYP	MAX	UNITS
t_{CSHD}	CLK to \overline{SYNC} hold time	10			ns
t_{SCSU}	\overline{SYNC} to CLK setup time	5			ns
t_{SYN}	Synchronize pulse width	1			CLK periods
t_{NDR}	Time for new data to be ready	127		128	Conversions ($1/f_{DATA}$)

8.3.11 Power-Down ($\overline{\text{PWDN}}$)

The channels of the ADS1278-SP can be independently powered down by use of the $\overline{\text{PWDN}}$ inputs. To enter the power-down mode, hold the respective $\overline{\text{PWDN}}$ pin low for at least two CLK cycles. To exit power-down, return the corresponding $\overline{\text{PWDN}}$ pin high. Note that when all channels are powered down, the ADS1278-SP enters a microwatt (μW) power state where all internal biasing is disabled. In this state, the TEST[1:0] input pins must be driven; all other input pins can float. The ADS1278-SP outputs remain driven.

As shown in [Figure 71](#) and [Table 10](#), a maximum of 130 conversion cycles must elapse for SPI interface, and 129 conversion cycles must elapse for Frame-Sync, before reading data after exiting power-down. Data from channels already running are not affected. The user software can perform the required delay time in any of the following ways:

1. Count the number of data conversions after taking the $\overline{\text{PWDN}}$ pin high.
2. Delay $129/f_{\text{DATA}}$ or $130/f_{\text{DATA}}$ after taking the $\overline{\text{PWDN}}$ pins high, then read data.

3. Detect for non-zero data in the powered-up channel.

After powering up one or more channels, the channels are synchronized to each other. It is not necessary to use the SYNC pin to synchronize them.

When a channel is powered down in TDM data format, the data for that channel are either forced to zero (fixed-position TDM data mode) or replaced by shifting the data from the next channel into the vacated data position (dynamic-position TDM data mode).

In Discrete data format, the data are always forced to zero. When powering-up a channel in dynamic-position TDM data format mode, the channel data remain packed until the data are ready, at which time the data frame is expanded to include the just-powered channel data. See the [Data Format](#) section for details.

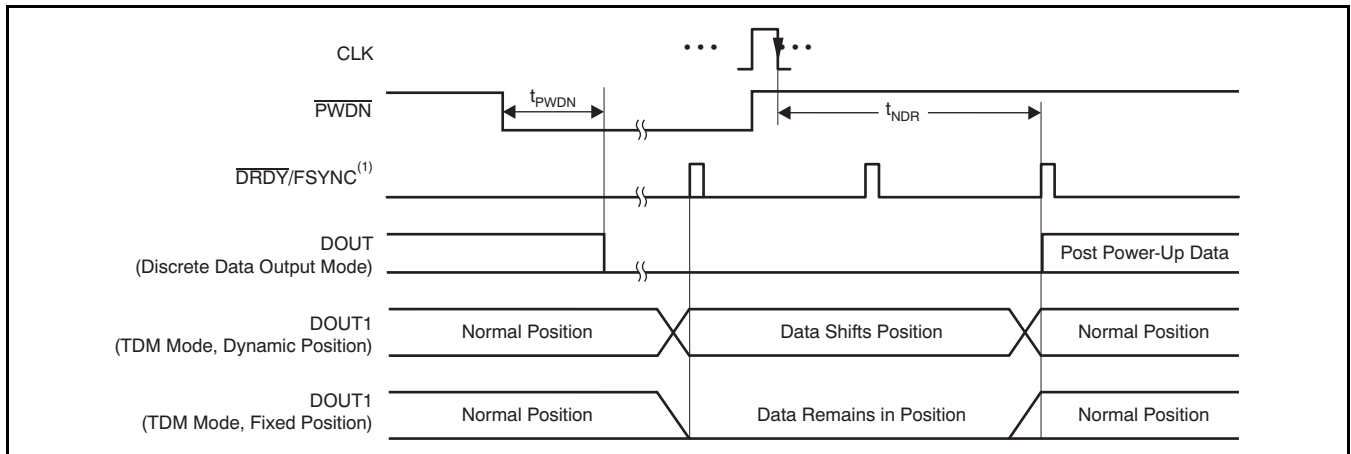

Figure 71. Power-Down Timing

Table 10. Power-Down Timing

SYMBOL	DESCRIPTION	MIN	TYP	MAX	UNITS
t_{PVDN}	PWDN pulse width to enter Power-Down mode	2			CLK periods
t_{NDR}	Time for new data ready (SPI)	129		130	Conversions ($1/f_{DATA}$)
t_{NDR}	Time for new data ready (Frame-Sync)	128		129	Conversions ($1/f_{DATA}$)

8.3.12 Format[2:0]

Data can be read from the ADS1278-SP with two interface protocols (SPI or Frame-Sync) and several options of data formats (TDM/Discrete and Fixed/Dynamic data positions). The FORMAT[2:0] inputs are used to select among the options. Table 11 lists the available options. See the *DOUT Modes* section for details of the DOUT Mode and Data Position.

Table 11. Data Output Format

FORMAT[2:0]	INTERFACE PROTOCOL	DOUT MODE	DATA POSITION
000	SPI	TDM	Dynamic
001	SPI	TDM	Fixed
010	SPI	Discrete	—
011	Frame-Sync	TDM	Dynamic
100	Frame-Sync	TDM	Fixed
101	Frame-Sync	Discrete	—
110	Modulator Mode	—	—

8.3.13 Serial Interface Protocols

Data are retrieved from the ADS1278-SP using the serial interface. Two protocols are available: SPI and Frame-Sync. The same pins are used for both interfaces: SCLK, $\overline{\text{DRDY}}$ /FSYNC, DOUT[8:1], and DIN. The FORMAT[2:0] pins select the desired interface protocol.

8.3.14 SPI Serial Interface

The SPI-compatible format is a read-only interface. Data ready for retrieval are indicated by the falling $\overline{\text{DRDY}}$ output and are shifted out on the falling edge of SCLK, MSB first. The interface can be daisy-chained using the DIN input when using multiple devices. See the *Daisy-Chaining* section for more information.

NOTE: The SPI format is limited to a CLK input frequency of 27 MHz, maximum. For CLK input operation above 27 MHz (High-Speed mode only), use Frame-Sync format.

8.3.14.1 SCLK

The serial clock (SCLK) features a Schmitt-triggered input and shifts out data on DOUT on the falling edge. It also shifts in data on the falling edge on DIN when this pin is being used for daisy-chaining. The device shifts data out on the falling edge and the user normally shifts this data in on the rising edge.

Even though the SCLK input has hysteresis, it is recommended to keep SCLK as clean as possible to prevent glitches from accidentally shifting the data.

SCLK may be run as fast as the CLK frequency. SCLK may be either in free-running or stop-clock operation between conversions. Note that one f_{CLK} is required after the falling edge of $\overline{\text{DRDY}}$ until the first rising edge of SCLK. For best performance, limit $f_{\text{SCLK}} / f_{\text{CLK}}$ to ratios of 1, 1/2, 1/4, 1/8, etc. When the device is configured for modulator output, SCLK becomes the modulator clock output (see the *Modulator Output* section).

8.3.14.2 $\overline{\text{DRDY}}$ /FSYNC (SPI Format)

In the SPI format, this pin functions as the $\overline{\text{DRDY}}$ output. It goes low when data are ready for retrieval and then returns high on the falling edge of the first subsequent SCLK. If data are not retrieved (that is, SCLK is held low), $\overline{\text{DRDY}}$ pulses high just before the next conversion data are ready, as shown in Figure 72. The new data are loaded within one CLK cycle before $\overline{\text{DRDY}}$ goes low. All data must be shifted out before this time to avoid being overwritten.

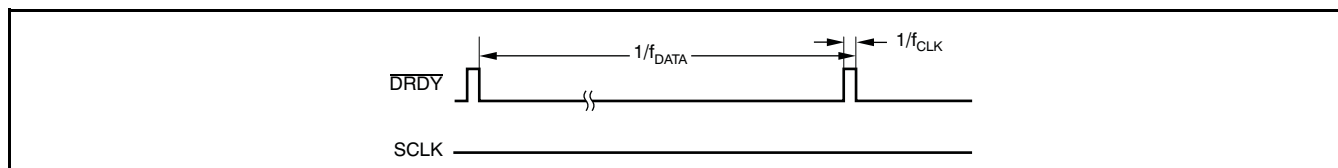

Figure 72. $\overline{\text{DRDY}}$ Timing With No Readback

8.3.14.3 DOUT

The conversion data are output on DOUT[8:1]. The MSB data are valid on DOUT[8:1] after $\overline{\text{DRDY}}$ goes low. Subsequent bits are shifted out with each falling edge of SCLK. If daisy-chaining, the data shifted in using DIN appear on DOUT after all channel data have been shifted out. When the device is configured for modulator output, DOUT[8:1] becomes the modulator data output for each channel (see the [Modulator Output](#) section).

8.3.14.4 DIN

This input is used when multiple ADS1278-SPs are to be daisy-chained together. The DOUT1 pin of the first device connects to the DIN pin of the next, etc. It can be used with either the SPI or Frame-Sync formats. Data are shifted in on the falling edge of SCLK. When using only one ADS1278-SP, tie DIN low. See the [Daisy-Chaining](#) section for more information.

8.3.15 Frame-Sync Serial Interface

Frame-Sync format is similar to the interface often used on audio ADCs. It operates in slave fashion—the user must supply framing signal FSYNC (similar to the *left/right clock* on stereo audio ADCs) and the serial clock SCLK (similar to the *bit clock* on audio ADCs). The data are output MSB first or *left-justified* on the rising edge of FSYNC. When using Frame-Sync format, the FSYNC and SCLK inputs must be continuously running with the relationships shown in the [Timing Requirements: Frame-Sync Format](#) table.

8.3.15.1 SCLK

The serial clock (SCLK) features a Schmitt-triggered input and shifts out data on DOUT on the falling edge. It also shifts in data on the falling edge on DIN when this pin is being used for daisy-chaining. Even though SCLK has hysteresis, it is recommended to keep SCLK as clean as possible to prevent glitches from accidentally shifting the data. When using Frame-Sync format, SCLK must run continuously. If it is shut down, the data readback will be corrupted. The number of SCLKs within a frame period (FSYNC clock) can be any power-of-2 ratio of CLK cycles (1, 1/2, 1/4, etc), as long as the number of cycles is sufficient to shift the data output from all channels within one frame. When the device is configured for modulator output, SCLK becomes the modulator clock output (see the [Modulator Output](#) section).

8.3.15.2 \overline{DRDY} /FSYNC (Frame-Sync Format)

In Frame-Sync format, this pin is used as the FSYNC input. The frame-sync input (FSYNC) sets the frame period, which must be the same as the data rate. The required number of f_{CLK} cycles to each FSYNC period depends on the mode selection and the CLKDIV input. [Table 5](#) indicates the number of CLK cycles to each frame (f_{CLK}/f_{DATA}). If the FSYNC period is not the proper value, data readback will be corrupted.

8.3.15.3 DOUT

The conversion data are shifted out on DOUT[8:1]. The MSB data become valid on DOUT[8:1] after FSYNC goes high. The subsequent bits are shifted out with each falling edge of SCLK. If daisy-chaining, the data shifted in using DIN appear on DOUT[8:1] after all channel data have been shifted out. When the device is configured for modulator output, DOUT becomes the modulator data output (see the [Modulator Output](#) section).

8.3.15.4 DIN

This input is used when multiple ADS1278-SPs are to be daisy-chained together. It can be used with either SPI or Frame-Sync formats. Data are shifted in on the falling edge of SCLK. When using only one ADS1278-SP, tie DIN low. See the [Daisy-Chaining](#) section for more information.

8.3.16 DOUT Modes

For both SPI and Frame-Sync interface protocols, the data are shifted out either through individual channel DOUT pins, in a parallel data format (Discrete mode), or the data for all channels are shifted out, in a serial format, through a common pin, DOUT1 (TDM mode).

8.3.16.1 TDM Mode

In TDM (time-division multiplexed) data output mode, the data for all channels are shifted out, in sequence, on a single pin (DOUT1). As shown in [Figure 73](#), the data from channel 1 are shifted out first, followed by channel 2 data, etc. After the data from the last channel are shifted out, the data from the DIN input follow. The DIN is used to daisy-chain the data output from an additional ADS1278-SP or other compatible device. Note that when all channels of the ADS1278-SP are disabled, the interface is disabled, rendering the DIN input disabled as well. When one or more channels of the device are powered down, the data format of the TDM mode can be fixed or dynamic.

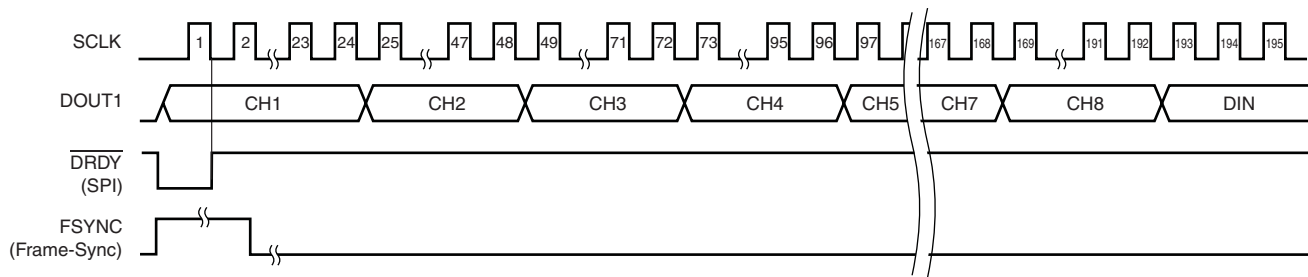

Figure 73. TDM Mode (All Channels Enabled)

8.3.16.2 TDM Mode, Fixed-Position Data

In this TDM data output mode, the data position of the channels remain fixed, regardless of whether the channels are powered down. If a channel is powered down, the data are forced to zero but occupy the same position within the data stream. Figure 74 shows the data stream with channel 1 and channel 3 powered down.

8.3.16.3 TDM Mode, Dynamic Position Data

In this TDM data output mode, when a channel is powered down, the data from higher channels shift one position in the data stream to fill the vacated data slot. Figure 75 shows the data stream with channel 1 and channel 3 powered down.

8.3.16.4 Discrete Data Output Mode

In Discrete data output mode, the channel data are shifted out in parallel using individual channel data output pins DOUT[8:1]. After the 24th SCLK, the channel data are forced to zero. The data are also forced to zero for powered down channels. Figure 76 shows the discrete data output format.

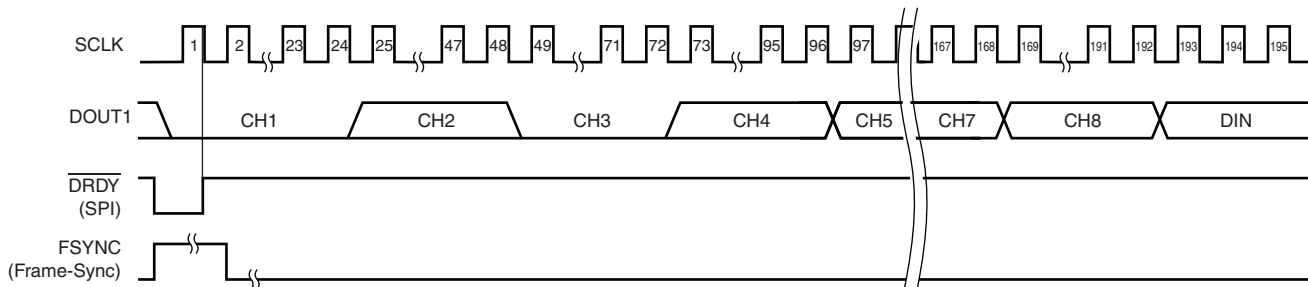

Figure 74. TDM Mode, Fixed-Position Data (Channels 1 And 3 Shown Powered Down)

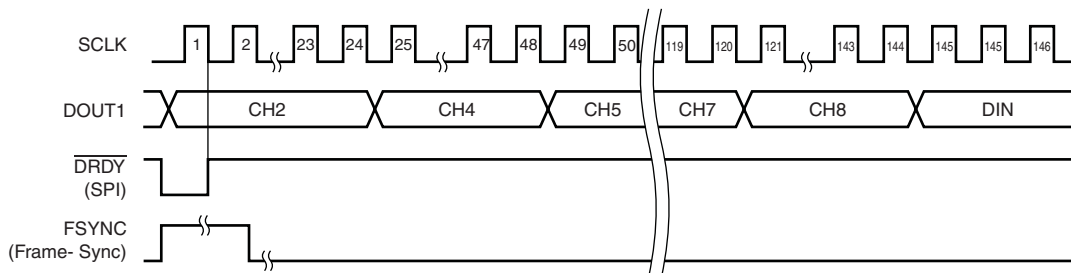

Figure 75. TDM Mode, Dynamic Position Data (Channels 1 And 3 Shown Powered Down)

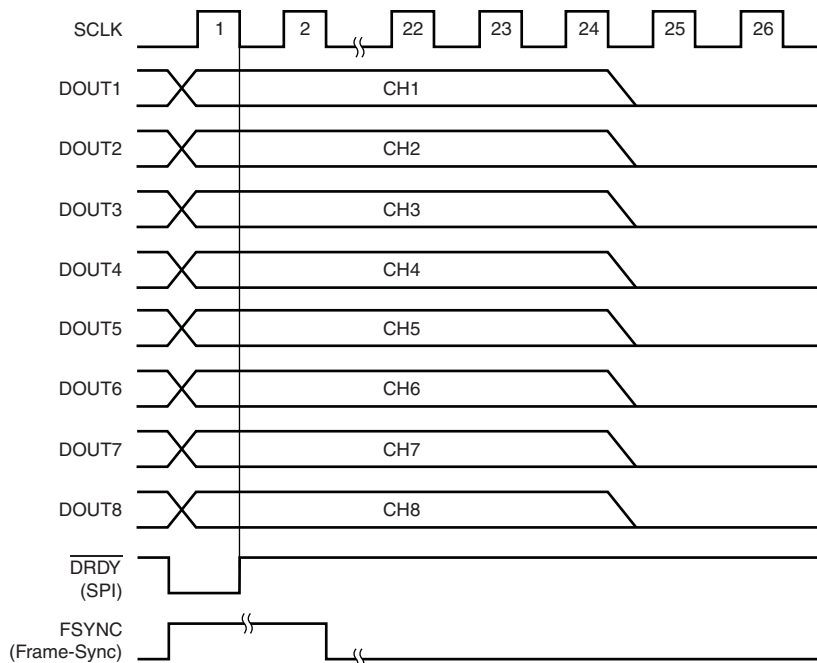

Figure 76. Discrete Data Output Mode

8.3.17 Daisy-Chaining

Multiple ADS1278-SPs can be daisy-chained together to output data on a single pin. The DOUT1 data output pin of one device is connected to the DIN of the next device. As shown in Figure 77, the DOUT1 pin of device 1 provides the output data to a controller, and the DIN of device 2 is grounded. Figure 78 shows the data format when reading back data.

The maximum number of channels that may be daisy-chained in this way is limited by the frequency of f_{SCLK} , the mode selection, and the CLKDIV input. The frequency of f_{SCLK} must be high enough to completely shift the data out from all channels within one f_{DATA} period. Table 12 lists the maximum number of daisy-chained channels when $f_{SCLK} = f_{CLK}$.

To increase the number of data channels possible in a chain, a segmented DOUT scheme may be used, producing two data streams. Figure 79 illustrates four ADS1278-SPs, with pairs of ADS1278-SPs daisy-chained together. The channel data of each daisy-chained pair are shifted out in parallel and received by the processor through independent data channels.

Table 12. Maximum Channels In A Daisy-Chain ($F_{SCLK} = F_{CLK}$)

MODE SELECTION	CLKDIV	MAXIMUM NUMBER OF CHANNELS
High-Speed	1	10
High-Resolution	1	21
Low-Power	1	21
	0	10
Low-Speed	1	106
	0	21

Whether the interface protocol is SPI or Frame-Sync, it is recommended to synchronize all devices by tying the SYNC inputs together. When synchronized in SPI protocol, it is only necessary to monitor the DRDY output of one ADS1278-SP.

In Frame-Sync interface protocol, the data from all devices are ready after the rising edge of FSYNC.

Since DOUT1 and DIN are both shifted on the falling edge of SCLK, the propagation delay on DOUT1 creates a setup time on DIN. Minimize the skew in SCLK to avoid timing violations.

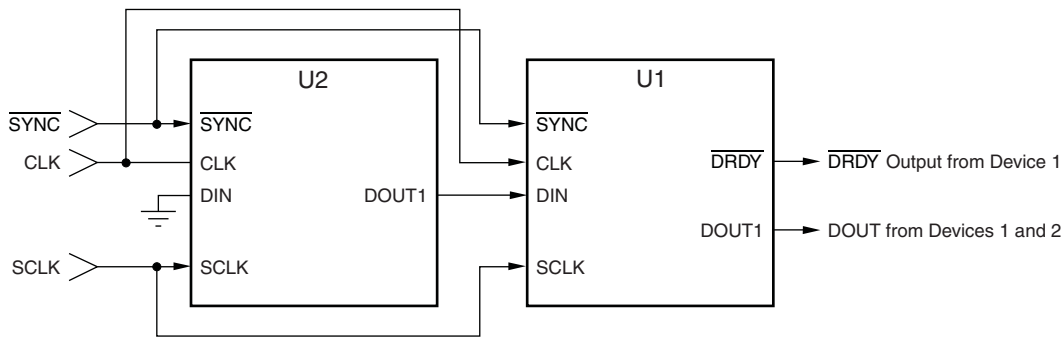

Note: The number of chained devices is limited by the SCLK rate and device mode.

Figure 77. Daisy-Chaining of Two Devices, SPI Protocol (Format[2:0] = 000 or 001)

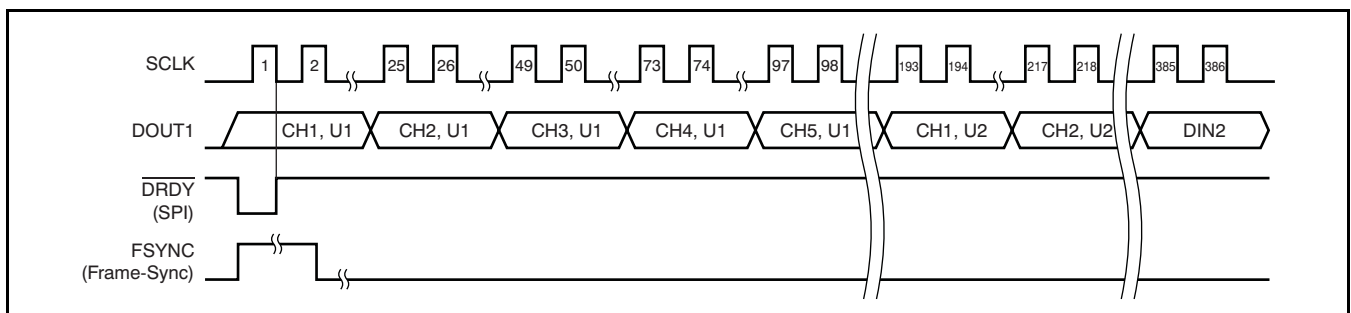
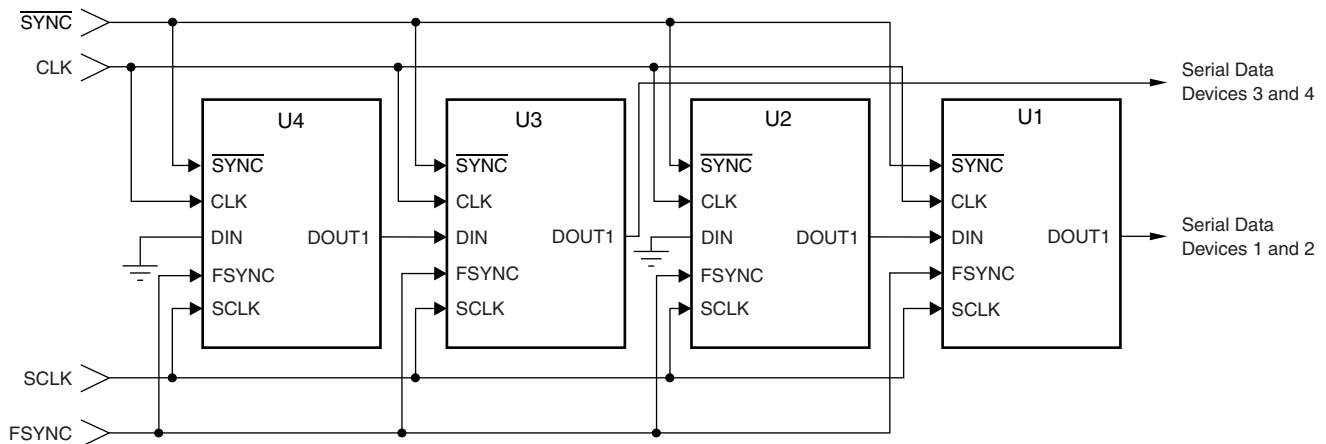

Figure 78. Daisy-Chain Data Format of Figure 77



Note: The number of chained devices is limited by the SCLK rate and device mode.

Figure 79. Segmented DOUT Daisy-Chain, Frame-Sync Protocol (Format[2:0] = 011 or 100)

8.3.18 Modulator Output

The ADS1278-SP incorporates a 6th-order, single-bit, chopper-stabilized modulator followed by a multi-stage digital filter that yields the conversion results. The data stream output of the modulator is available directly, bypassing the internal digital filter. The digital filter is disabled, reducing the DVDD current, as shown in [Table 13](#). In this mode, an external digital filter implemented in an ASIC, FPGA, or similar device is required. To invoke the modulator output, tie FORMAT[2:0], as shown in [Figure 80](#). DOUT[8:1] then becomes the modulator data stream outputs for each channel and SCLK becomes the modulator clock output. The DRDY/FSYNC pin becomes an unused output and can be ignored. The normal operation of the Frame-Sync and SPI interfaces is disabled, and the functionality of SCLK changes from an input to an output, as shown in [Figure 80](#).

Table 13. Modulator Output Clock Frequencies

MODE [1:0]	CLKDIV	MODULATOR CLOCK OUTPUT (SCLK)	DVDD (mA)
00	1	$f_{CLK} / 4$	8
01	1	$f_{CLK} / 4$	7
10	1	$f_{CLK} / 8$	4
	0	$f_{CLK} / 4$	4
11	1	$f_{CLK} / 40$	1
	0	$f_{CLK} / 8$	1

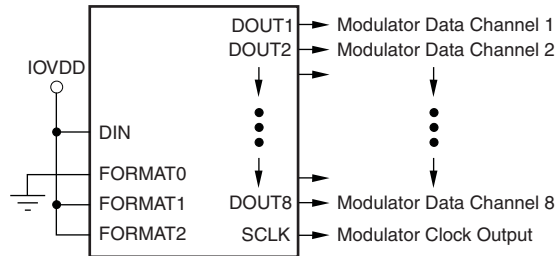

Figure 80. Modulator Output

In modulator output mode, the frequency of the modulator clock output (SCLK) depends on the mode selection of the ADS1278-SP. Table 13 lists the modulator clock output frequency and DVDD current versus device mode.

Figure 81 shows the timing relationship of the modulator clock and data outputs.

The data output is a modulated 1s density data stream. When $V_{IN} = +V_{REF}$, the 1s density is approximately 80% and when $V_{IN} = -V_{REF}$, the 1s density is approximately 20%.

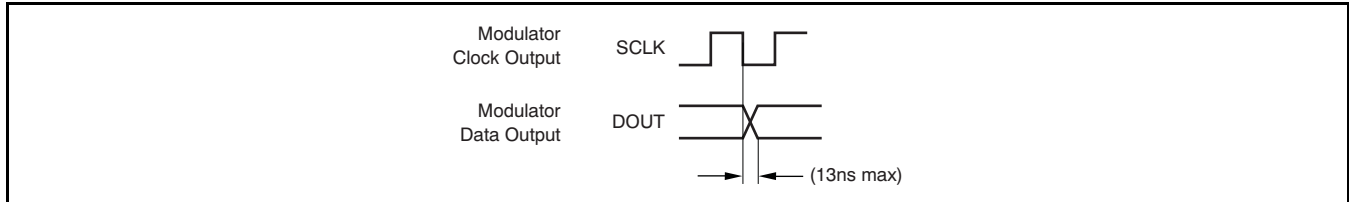

Figure 81. Modulator Output Timing

8.3.19 Pin Test Using Test[1:0] Inputs

The test mode feature of the ADS1278-SP allows continuity testing of the digital I/O pins. In this mode, the normal functions of the digital pins are disabled and routed to each other as pairs through internal logic, as shown in Table 14. The pins in the left column drive the output pins in the right column. **Note:** some of the digital input pins become outputs; these outputs must be accommodated in the design. The analog input, power supply, and ground pins all remain connected as normal. The test mode is engaged by setting the pins TEST [1:0] = 11. For normal converter operation, set TEST[1:0] = 00. Do not use '01' or '10'.

Table 14. Test Mode Pin Map (Test[1:0] = 11)

TEST MODE PIN MAP	
INPUT PINS	OUTPUT PINS
$\overline{\text{PWDN}}1$	DOUT1
$\overline{\text{PWDN}}2$	DOUT2
$\overline{\text{PWDN}}3$	DOUT3
$\overline{\text{PWDN}}4$	DOUT4
$\overline{\text{PWDN}}5$	DOUT5
$\overline{\text{PWDN}}6$	DOUT6
$\overline{\text{PWDN}}7$	DOUT7
$\overline{\text{PWDN}}8$	DOUT8
MODE0	DIN
MODE1	$\overline{\text{SYNC}}$
FORMAT0	CLKDIV
FORMAT1	$\overline{\text{FSYNC/DRDY}}$
FORMAT2	SCLK

8.3.20 VCOM Output

The VCOM pin provides a voltage output equal to $AVDD / 2$. The intended use of this output is to set the output common-mode level of the analog input drivers. The drive capability of the output is limited; therefore, the output should only be used to drive high-impedance nodes ($> 1 \text{ M}\Omega$). In some cases, an external buffer may be necessary. A 0.1- μF bypass capacitor is recommended to reduce noise pickup.

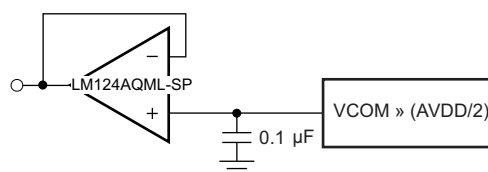

Figure 82. VCOM Output

8.4 Device Functional Modes

Table 15. Operating Mode Performance Summary

MODE	MAX DATA RATE (SPS)	PASSBAND (kHz)	SNR (dB)	NOISE (μV_{RMS})	POWER/CHANNEL (mW)
High-Speed	128,000	57,984	106	8.5	70
High-Resolution	52,734	23,889	110	5.5	64
Low-Power	52,734	23,889	106	8.5	31
Low-Speed	10,547	4,798	107	8.0	7

9 Application and Implementation

NOTE

Information in the following applications sections is not part of the TI component specification, and TI does not warrant its accuracy or completeness. TI's customers are responsible for determining suitability of components for their purposes. Customers should validate and test their design implementation to confirm system functionality.

9.1 Application Information

The ADS1278-SP is a radiation-hardened high resolution delta-sigma ADC that is ideal for precision sensing and high accuracy instrumentation applications. With eight simultaneous sampling 24-bit ADCs integrated, the device reduces the board area needed to digitize eight analog signals.

9.2 Typical Application

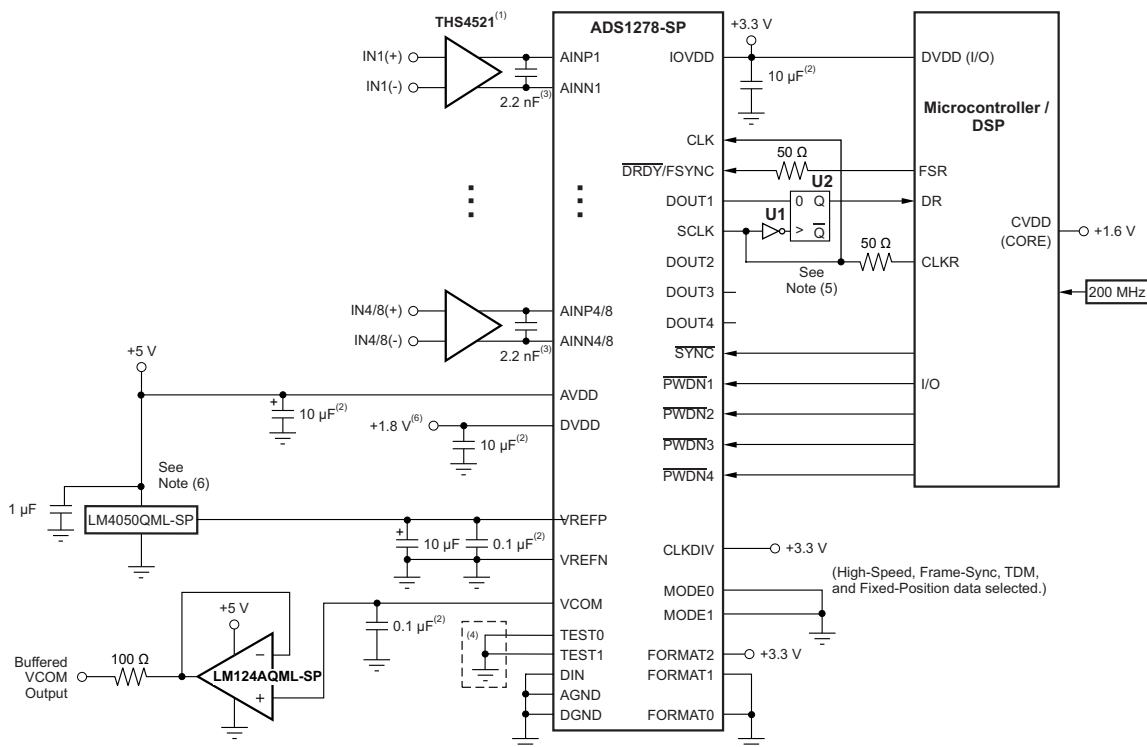

Figure 83. Typical Application Schematic

9.2.1 Design Requirements

Depending on the accuracy and speed requirements of the sensing application to be digitized by the ADC1278-SP, users must first determine the optimal device configuration. Table 16 shows the possible configurations for device for the maximum fCLKIN for each configuration. The yellow highlighted columns indicate user defined inputs (through I/O pins) to the device, while the italic row indicates the default configuration of the ADS1278EVM-CVAL EVM that is available as a reference design. As shown, a maximum data rate of 52734 SPS is possible while using the High Resolution mode, which yields a typical SNR of 111 dB or an ENOB of 18 bits.

Typical Application (continued)

Table 16. ADS1278-SP Configuration Modes

Mode	CLKDIV	fCLK/fMOD	fCLKIN_max (MHz)	Oversampling (fMOD/fDATA)	fMOD (MHz)	fDATA_max (SPS)	fCLKIN/fMOD
High-Speed	1	4	32.768	64	8.192	128000	4
High-Speed	1	4	32.768	64	8.192	128000	4
<i>High-Speed</i>	<i>1</i>	<i>4</i>	<i>27</i>	<i>64</i>	<i>6.75</i>	<i>105469</i>	<i>4</i>
High Resolution	1	4	27	128	6.75	52734	4
Low-Power	1	8	27	64	3.375	52734	8
Low-Power	0	4	13.5	64	3.375	52734	4
Low-Speed	1	40	27	64	0.675	10547	40
Low-Speed	0	8	5.4	64	0.675	10547	8

9.2.2 Detailed Design Procedure

To obtain the specified performance from the ADS1278-SP, the following layout and component guidelines should be considered.

- Power Supplies:** The device requires three power supplies for operation: DVDD, IOVDD, and AVDD. The allowed range for DVDD is 1.65 V to 1.95 V; the range of IOVDD is 1.65 V to 3.6 V; AVDD is restricted to 4.75 V to 5.25 V. For all supplies, use a 10- μ F tantalum capacitor, bypassed with a 0.1- μ F ceramic capacitor, placed close to the device pins. Alternatively, a single 10- μ F ceramic capacitor can be used. The supplies should be relatively free of noise and should not be shared with devices that produce voltage spikes (such as relays, LED display drivers, etc.). If a switching power-supply source is used, the voltage ripple should be low (less than 2 mV) and the switching frequency outside the passband of the converter.
- Ground Plane:** A single ground plane connecting both AGND and DGND pins can be used. If separate digital and analog grounds are used, connect the grounds together at the converter.
- Digital Inputs:** It is recommended to source-terminate the digital inputs to the device with 50- Ω series resistors. The resistors should be placed close to the driving end of digital source (oscillator, logic gates, DSP, etc.) This placement helps to reduce ringing on the digital lines (ringing may lead to degraded ADC performance).
- Analog/Digital Circuits:** Place analog circuitry (input buffer, reference) and associated tracks together, keeping them away from digital circuitry (DSP, microcontroller, logic). Avoid crossing digital tracks across analog tracks to reduce noise coupling and crosstalk.
- Reference Inputs:** It is recommended to use a minimum 10- μ F tantalum with a 0.1- μ F ceramic capacitor directly across the reference inputs, VREFP and VREFN. The reference input should be driven by a low-impedance source. For best performance, the reference should have less than 3- μ V_{RMS} in-band noise. For references with noise higher than this level, external reference filtering may be necessary.
- Analog Inputs:** The analog input pins must be driven differentially to achieve specified performance. A true differential driver or transformer (ac applications) can be used for this purpose. Route the analog input tracks (AINP, AINN) as a pair from the buffer to the converter using short, direct tracks and away from digital tracks. A 1-nF to 10-nF capacitor should be used directly across the analog input pins, AINP and AINN. A low-k dielectric (such as COG or film type) should be used to maintain low THD. Capacitors from each analog input to ground can be used. They should be no larger than 1/10 the size of the difference capacitor (typically 100 pF) to preserve the ac common-mode performance.
- Component Placement:** Place the power supply, analog input, and reference input bypass capacitors as close as possible to the device pins. This layout is particularly important for small-value ceramic capacitors. Larger (bulk) decoupling capacitors can be located farther from the device than the smaller ceramic capacitors.

9.2.3 Application Curve

Figure 84 illustrates how the noise of the device, and thus, the SNR, is determined by the mode that is utilized.

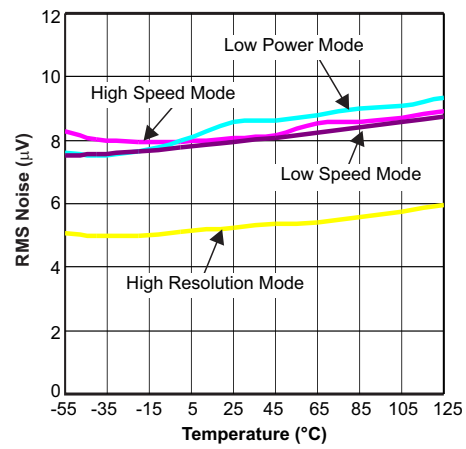

Figure 84. Noise vs Temperature

10 Power Supply Recommendations

The ADS1278-SP has three power supplies: AVDD, DVDD, and IOVDD. AVDD is the analog supply that powers the modulator, DVDD is the digital supply that powers the digital core, and IOVDD is the digital I/O power supply. The IOVDD and DVDD power supplies can be tied together if desired (1.8 V). To achieve rated performance, it is critical that the power supplies are bypassed with 0.1- μ F and 10- μ F capacitors placed as close as possible to the supply pins. A single 10- μ F ceramic capacitor may be substituted in place of the two capacitors.

Figure 85 shows the start-up sequence of the ADS1278-SP. At power-on, bring up the DVDD supply first, followed by IOVDD and then AVDD. Check the power-supply sequence for proper order, including the ramp rate of each supply. DVDD and IOVDD may be sequenced at the same time if the supplies are tied together. Each supply has an internal reset circuit whose outputs are summed together to generate a global power-on reset. After the supplies have exceeded the reset thresholds, 2^{18} f_{CLK} cycles are counted before the converter initiates the conversion process. Following the CLK cycles, the data for 129 conversions are suppressed by the ADS1278-SP to allow output of fully-settled data. In SPI protocol, \overline{DRDY} is held high during this interval. In frame-sync protocol, DOUT is forced to zero. The power supplies should be applied before any analog or digital pin is driven. For consistent performance, assert SYNC after device power-on when data first appear.

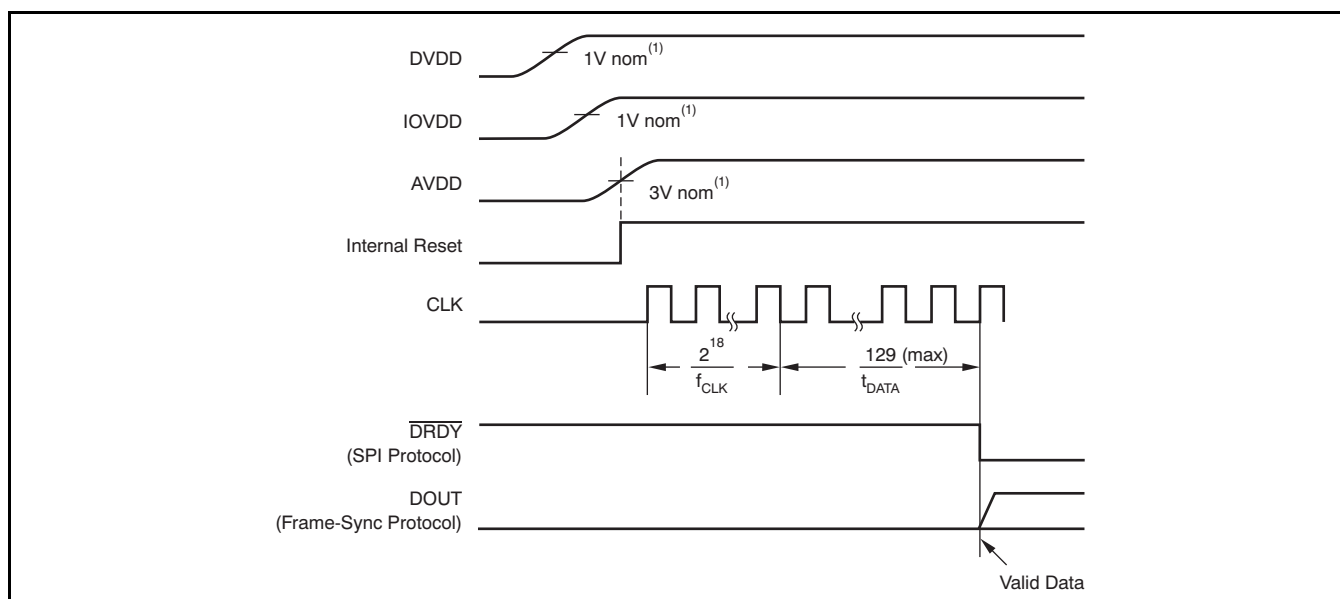

Figure 85. Start-Up Sequence

11 Layout

11.1 Layout Guidelines

In any mixed-signal system design, the power-supply and grounding design plays a significant role. The device distinguishes between two different grounds: AVSS (analog ground) and DGND (digital ground). In low frequency applications such as temperature sensing with thermocouples, laying out the printed circuit board (PCB) to use a single ground plane is adequate but care must be taken so that ground loops are avoided. Ground loops act as loop antennas picking up interference currents which transform into voltage fluctuations. These fluctuations are effectively noise which can degrade system performance in high resolution applications. When placing components and routing over the ground plane, pay close attention to the path that ground currents will take. Avoid having return currents for digital functions pass close to analog sensitive devices or traces.

Additionally, the proximity of digital devices to an analog signal chain has the potential to induce unwanted noise into the system. One primary source of noise is the switching noise from any digital circuitry such as the data output serializer or the microprocessor receiving the data. For the device, care must be taken to ensure that the interaction between the analog and digital supplies within the device is kept to a minimal amount. The extent of noise coupled and transmitted from the digital and analog sections depends on the effective inductances of each of the supply and ground connections. Smaller effective inductances of the supply and ground pins results in better noise suppression. For this reason, multiple pins are used to connect to the digital ground. Low inductance properties must be maintained throughout the design of the PCB layout by use of proper planes and layer thickness.

To avoid noise coupling through supply pins, TI recommends to keep sensitive input pins away from the DVDD and DGND planes. Do not route the traces or vias connected to these pins across these planes; that is, avoid the digital power planes under the analog input pins. Care should be taken to minimize inductance and route digital signals away from analog section.

The analog inputs represent the most sensitive node of the ADC as the total system accuracy depends on the how well the integrity of this signal is maintained. The analog differential inputs to the ADC should be routed tightly coupled and symmetrical for common mode rejection. These inputs should be as short in length as possible to minimize exposure to potential sources of noise.

11.2 Layout Example

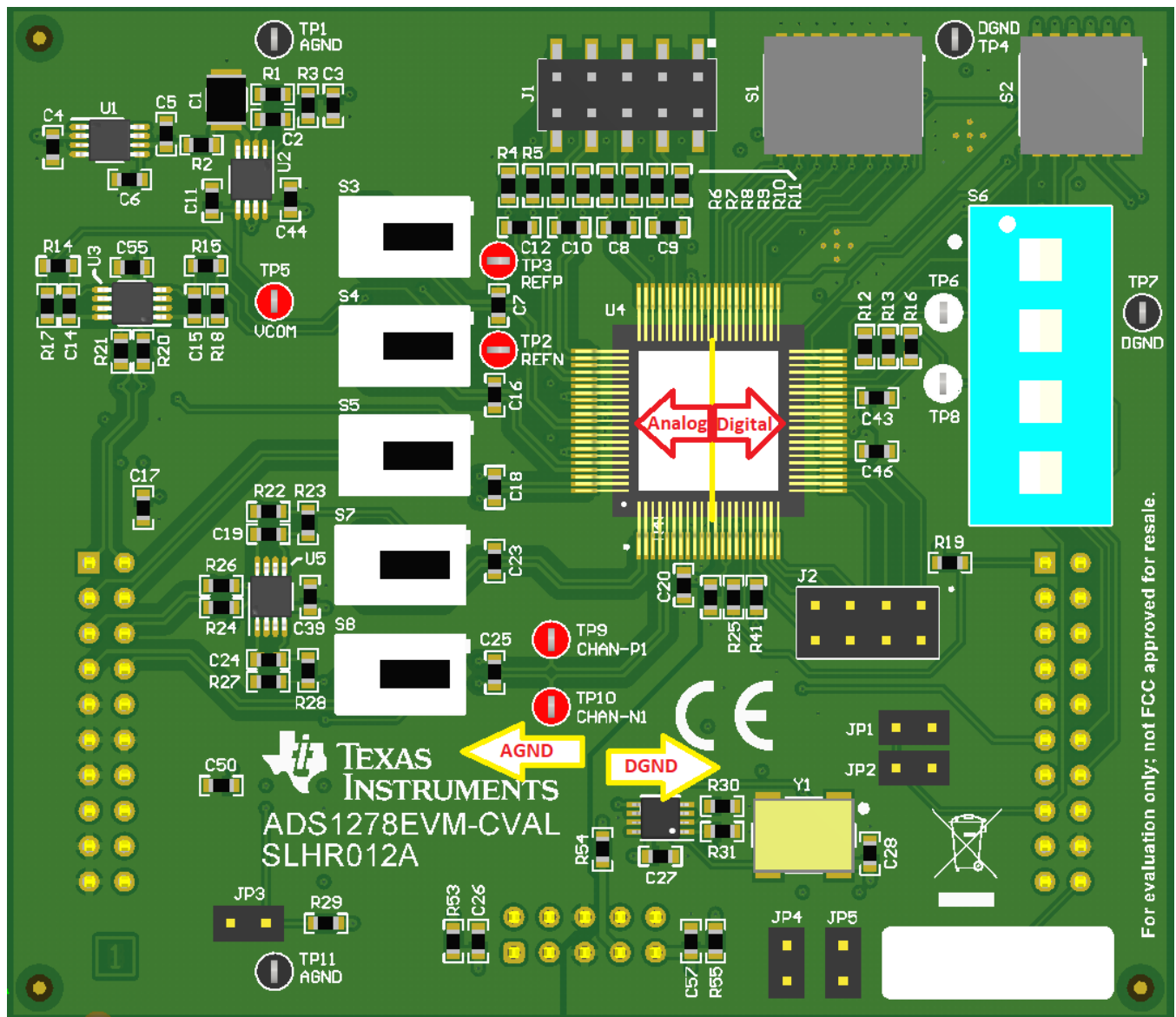

Figure 86. ADS1278-SP Layout Example

12 デバイスおよびドキュメントのサポート

12.1 ドキュメントの更新通知を受け取る方法

ドキュメントの更新についての通知を受け取るには、ti.comのデバイス製品フォルダを開いてください。右上の「アラートを受け取る」をクリックして登録すると、変更されたすべての製品情報に関するダイジェストを毎週受け取れます。変更の詳細については、修正されたドキュメントに含まれている改訂履歴をご覧ください。

12.2 コミュニティ・リソース

The following links connect to TI community resources. Linked contents are provided "AS IS" by the respective contributors. They do not constitute TI specifications and do not necessarily reflect TI's views; see TI's [Terms of Use](#).

TI E2E™オンライン・コミュニティ *TIのE2E (Engineer-to-Engineer) コミュニティ*。エンジニア間の共同作業を促進するために開設されたものです。e2e.ti.comでは、他のエンジニアに質問し、知識を共有し、アイデアを検討して、問題解決に役立てることができます。

設計サポート *TIの設計サポート* 役に立つE2Eフォーラムや、設計サポート・ツールをすばやく見つけることができます。技術サポート用の連絡先情報も参照できます。

12.3 商標

E2E is a trademark of Texas Instruments.

SPI is a trademark of Motorola, Inc.

All other trademarks are the property of their respective owners.

12.4 静電気放電に関する注意事項



すべての集積回路は、適切なESD保護方法を用いて、取扱いと保存を行うようにして下さい。

静電気放電はわずかな性能の低下から完全なデバイスの故障に至るまで、様々な損傷を与えます。高精度の集積回路は、損傷に対して敏感であり、極めてわずかなパラメータの変化により、デバイスに規定された仕様に適合しなくなる場合があります。

12.5 Glossary

SLYZ022 — *TI Glossary*.

This glossary lists and explains terms, acronyms, and definitions.

13 メカニカル、パッケージ、および注文情報

以降のページには、メカニカル、パッケージ、および注文に関する情報が記載されています。この情報は、そのデバイスについて利用可能な最新のデータです。このデータは予告なく変更されることがあり、ドキュメントが改訂される場合もあります。本データシートのブラウザ版を使用されている場合は、画面左側の説明をご覧ください。

PACKAGING INFORMATION

Orderable Device	Status (1)	Package Type	Package Drawing	Pins	Package Qty	Eco Plan (2)	Lead finish/ Ball material (6)	MSL Peak Temp (3)	Op Temp (°C)	Device Marking (4/5)	Samples
ADS1278HFQ/EM	ACTIVE	CFP	HFQ	84	1	RoHS-Exempt & Green	Call TI	Call TI	25 to 25	ADS1278HFQ/EM EVAL ONLY	Samples
ADS1278MHFQ-MLS	ACTIVE	CFP	HFQ	84	1	RoHS-Exempt & Green	Call TI	Call TI	-55 to 125	ADS1278MHFQ-MLS	Samples
ADS1278WHFQ-MLS	ACTIVE	CFP	HFQ	84	1	RoHS-Exempt & Green	Call TI	Call TI	-55 to 115	ADS1278 WHFQ-MLS	Samples

(1) The marketing status values are defined as follows:

ACTIVE: Product device recommended for new designs.

LIFEBUY: TI has announced that the device will be discontinued, and a lifetime-buy period is in effect.

NRND: Not recommended for new designs. Device is in production to support existing customers, but TI does not recommend using this part in a new design.

PREVIEW: Device has been announced but is not in production. Samples may or may not be available.

OBSOLETE: TI has discontinued the production of the device.

(2) **RoHS:** TI defines "RoHS" to mean semiconductor products that are compliant with the current EU RoHS requirements for all 10 RoHS substances, including the requirement that RoHS substance do not exceed 0.1% by weight in homogeneous materials. Where designed to be soldered at high temperatures, "RoHS" products are suitable for use in specified lead-free processes. TI may reference these types of products as "Pb-Free".

RoHS Exempt: TI defines "RoHS Exempt" to mean products that contain lead but are compliant with EU RoHS pursuant to a specific EU RoHS exemption.

Green: TI defines "Green" to mean the content of Chlorine (Cl) and Bromine (Br) based flame retardants meet JS709B low halogen requirements of <=1000ppm threshold. Antimony trioxide based flame retardants must also meet the <=1000ppm threshold requirement.

(3) MSL, Peak Temp. - The Moisture Sensitivity Level rating according to the JEDEC industry standard classifications, and peak solder temperature.

(4) There may be additional marking, which relates to the logo, the lot trace code information, or the environmental category on the device.

(5) Multiple Device Markings will be inside parentheses. Only one Device Marking contained in parentheses and separated by a "~" will appear on a device. If a line is indented then it is a continuation of the previous line and the two combined represent the entire Device Marking for that device.

(6) Lead finish/Ball material - Orderable Devices may have multiple material finish options. Finish options are separated by a vertical ruled line. Lead finish/Ball material values may wrap to two lines if the finish value exceeds the maximum column width.

Important Information and Disclaimer:The information provided on this page represents TI's knowledge and belief as of the date that it is provided. TI bases its knowledge and belief on information provided by third parties, and makes no representation or warranty as to the accuracy of such information. Efforts are underway to better integrate information from third parties. TI has taken and continues to take reasonable steps to provide representative and accurate information but may not have conducted destructive testing or chemical analysis on incoming materials and chemicals. TI and TI suppliers consider certain information to be proprietary, and thus CAS numbers and other limited information may not be available for release.

In no event shall TI's liability arising out of such information exceed the total purchase price of the TI part(s) at issue in this document sold by TI to Customer on an annual basis.

OTHER QUALIFIED VERSIONS OF ADS1278-SP :

- Catalog : [ADS1278](#)
- Enhanced Product : [ADS1278-EP](#)

NOTE: Qualified Version Definitions:

- Catalog - TI's standard catalog product
- Enhanced Product - Supports Defense, Aerospace and Medical Applications

HFQ (S-CQFP-F84)

CERAMIC QUAD FLATPACK WITH NCTB

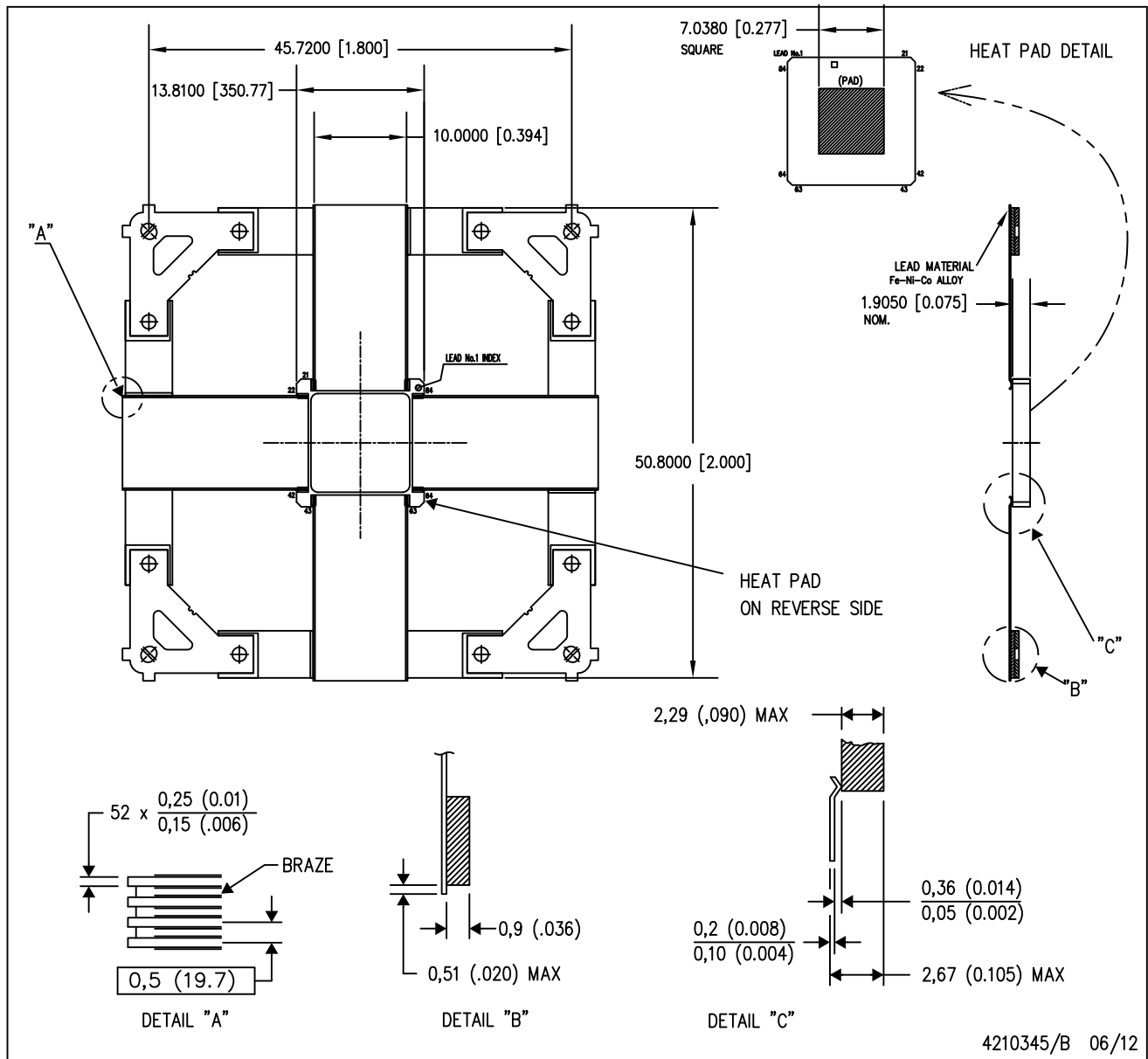

4210345/B 06/12

- NOTES:
- A. All linear dimensions are in millimeters (inches).
 - B. This drawing is subject to change without notice.
 - C. Ceramic quad flatpack with flat leads brazed to non-conductive tie bar carrier.
 - D. This package is hermetically sealed with a metal lid.
 - E. The leads are gold plated and can be solderdipped.
 - F. Leads not shown for clarity purposes.
 - G. Lid and heat sink are connected to GND leads.

重要なお知らせと免責事項

TI は、技術データと信頼性データ(データシートを含みます)、設計リソース(リファレンス・デザインを含みます)、アプリケーションや設計に関する各種アドバイス、Web ツール、安全性情報、その他のリソースを、欠陥が存在する可能性のある「現状のまま」提供しており、商品性および特定目的に対する適合性の黙示保証、第三者の知的財産権の非侵害保証を含むいかなる保証も、明示的または黙示的にかかわらず拒否します。

これらのリソースは、TI 製品を使用する設計の経験を積んだ開発者への提供を意図したものです。(1) お客様のアプリケーションに適した TI 製品の選定、(2) お客様のアプリケーションの設計、検証、試験、(3) お客様のアプリケーションに該当する各種規格や、その他のあらゆる安全性、セキュリティ、規制、または他の要件への確実な適合に関する責任を、お客様のみが単独で負うものとし、

上記の各種リソースは、予告なく変更される可能性があります。これらのリソースは、リソースで説明されている TI 製品を使用するアプリケーションの開発の目的でのみ、TI はその使用をお客様に許諾します。これらのリソースに関して、他の目的で複製することや掲載することは禁止されています。TI や第三者の知的財産権のライセンスが付与されている訳ではありません。お客様は、これらのリソースを自身で使用した結果発生するあらゆる申し立て、損害、費用、損失、責任について、TI およびその代理人を完全に補償するものとし、TI は一切の責任を拒否します。

TI の製品は、[TI の販売条件](#)、または [ti.com](https://www.ti.com) やかかる TI 製品の関連資料などのいずれかを通じて提供する適用可能な条項の下で提供されています。TI がこれらのリソースを提供することは、適用される TI の保証または他の保証の放棄の拡大や変更を意味するものではありません。

お客様がいかなる追加条項または代替条項を提案した場合でも、TI はそれらに異議を唱え、拒否します。

郵送先住所 : Texas Instruments, Post Office Box 655303, Dallas, Texas 75265

Copyright © 2022, Texas Instruments Incorporated