

# AMC0106M25 高精度、 $\pm 250\text{mV}$ 入力、機能絶縁、外部クロックによるデルタ シグマ変調器

## 1 特長

- リニア入力電圧範囲:  $\pm 250\text{mV}$
- 電源電圧範囲:
  - ハイサイド (AVDD):  $3.0\text{V} \sim 5.5\text{V}$
  - ローサイド (DVDD):  $2.7\text{V} \sim 5.5\text{V}$
- 小さい DC 誤差:
  - オフセット誤差:  $\pm 200\mu\text{V}$  (最大値)
  - オフセットドリフト:  $\pm 3\mu\text{V}/^\circ\text{C}$  (最大値)
  - ゲイン誤差:  $\pm 0.2\%$  (最大値)
  - ゲインドリフト:  $\pm 40\text{ppm}/^\circ\text{C}$  (最大値)
- 高 CMTI:  $150\text{V}/\text{ns}$  (最小値)
- ハイサイド電源喪失の検出
- 低 EMI: CISPR-11 および CISPR-25 規格に準拠
- 機能的分離:
  - $200\text{V}_{\text{RMS}}$ 、 $280\text{V}_{\text{DC}}$  の動作電圧
  - $570\text{V}_{\text{RMS}}$ 、 $800\text{V}_{\text{DC}}$  の過渡的過電圧 (60s)
- 拡張産業用温度範囲にわたって仕様を完全に規定  $-40^\circ\text{C} \sim +125^\circ\text{C}$

## 2 アプリケーション

- 48V モータードライブ
- 48V 周波数インバータ
- アナログ入力モジュール
- 電源

## 3 概要

AMC0106M25 は、 $\pm 250\text{mV}$  の入力電圧範囲を持つ高精度の機能絶縁デルタ シグマ変調器です。この絶縁バリアは、異なる同相電圧レベルで動作するシステム領域を分離します。この絶縁バリアは、最高  $200\text{V}_{\text{RMS}}$  または  $280\text{V}_{\text{DC}}$  の動作電圧と、最高  $570\text{V}_{\text{RMS}}$  または  $800\text{V}_{\text{DC}}$  の過渡電圧に対応しています。

AMC0106M25 は、小さいパッケージ サイズと低い入力電圧範囲を備え、スペースに制約のあるアプリケーションでの高精度絶縁型電流センシングを実現するように設計されています。ガルバニック絶縁バリアは高い同相過渡に対応し、感受性の高い制御回路を電力段のスイッチングノイズから絶縁できます。

AMC0106M25 の出力ビットストリームは、外部クロックと同期します。このデバイスは、 $\text{sinc}^3$  や OSR 256 フィルタと組み合わせることにより、16 ビットの分解能、86dB のダイナミックレンジ、78kSPS のデータレートを実現します。

AMC0106M25 は 8 ピン、0.65mm ピッチの VSON パッケージで供給され、 $-40^\circ\text{C} \sim +125^\circ\text{C}$  の拡張産業用温度範囲で動作が規定されています。

### パッケージ情報

部品番号	パッケージ (1)	パッケージ サイズ (2)
AMC0106M25	DEN (VSON, 8)	3.5mm × 2.7mm

- (1) 詳細については、「メカニカル、パッケージ、および注文情報」を参照してください。
- (2) パッケージ サイズ (長さ × 幅) は公称値であり、該当する場合はピンも含まれます。

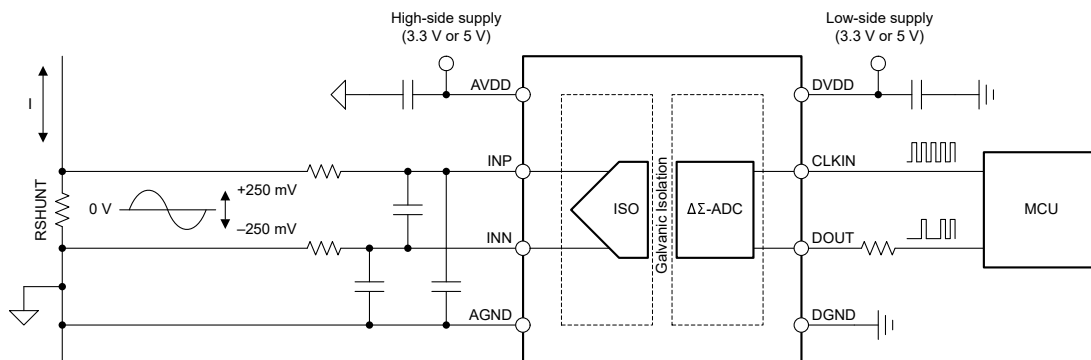

代表的なアプリケーション



## Table of Contents

<b>1 特長</b> .....	<b>1</b>	<b>7 Application and Implementation</b> .....	<b>15</b>
<b>2 アプリケーション</b> .....	<b>1</b>	7.1 Application Information.....	15
<b>3 概要</b> .....	<b>1</b>	7.2 Typical Application.....	15
<b>4 Pin Configuration and Functions</b> .....	<b>3</b>	7.3 Best Design Practices.....	18
<b>5 Specifications</b> .....	<b>4</b>	7.4 Power Supply Recommendations.....	19
5.1 Absolute Maximum Ratings .....	4	7.5 Layout.....	19
5.2 ESD Ratings.....	4	<b>8 Device and Documentation Support</b> .....	<b>20</b>
5.3 Recommended Operating Conditions .....	5	8.1 Documentation Support.....	20
5.4 Thermal Information (DEN Package).....	6	8.2 ドキュメントの更新通知を受け取る方法.....	20
5.5 Package Characteristics .....	6	8.3 サポート・リソース.....	20
5.6 Electrical Characteristics .....	7	8.4 Trademarks.....	20
5.7 Switching Characteristics .....	9	8.5 静電気放電に関する注意事項.....	20
5.8 Timing Diagrams.....	9	8.6 用語集.....	20
<b>6 Detailed Description</b> .....	<b>10</b>	<b>9 Revision History</b> .....	<b>20</b>
6.1 Overview.....	10	<b>10 Mechanical, Packaging, and Orderable Information</b> .....	<b>20</b>
6.2 Functional Block Diagram.....	10	10.1 Mechanical Data.....	21
6.3 Feature Description.....	11		
6.4 Device Functional Modes.....	14		

## 4 Pin Configuration and Functions



図 4-1. DEN Package, 8-Pin VSON (Top View)

表 4-1. Pin Functions

PIN		TYPE	DESCRIPTION
NO.	NAME		
1	AVDD	High-side power	Analog (high-side) power supply. <sup>(1)</sup>
2	INP	Analog input	Noninverting analog input. Connect a 10nF filter capacitor from INP to INN.
3	INN	Analog input	Inverting analog input. Connect a 10nF filter capacitor from INP to INN.
4, 9 <sup>(2)</sup>	AGND	High-side ground	Analog (high-side) ground.
5, 10 <sup>(2)</sup>	DGND	Low-side ground	Digital (low-side) ground.
6	DOUT	Digital output	Modulator data output.
7	CLKIN	Digital input	Modulator clock input with internal pulldown resistor (typical value: 1.5MΩ).
8	DVDD	Low-side power	Digital (low-side) power supply. <sup>(1)</sup>

- (1) See the [Power Supply Recommendations](#) section for power-supply decoupling recommendations.  
 (2) Both pins are connected internally with a low-impedance path.

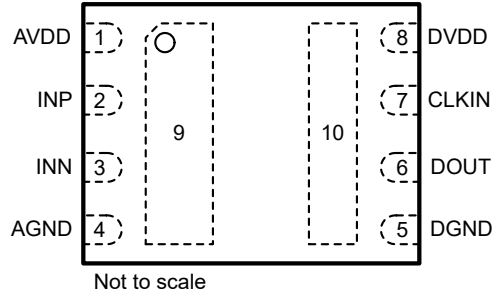
## 5 Specifications

### 5.1 Absolute Maximum Ratings

see (1)

		MIN	MAX	UNIT
Power-supply voltage	High-side AVDD to AGND	-0.3	6.5	V
	Low-side DVDD to DGND	-0.3	6.5	
Analog input voltage	INP, INN	AGND - 4	AVDD + 0.5	V
Digital input voltage	CLKIN	DGND - 0.5	DVDD+ 0.5	V
Digital output voltage	DOUT	DGND - 0.5	DVDD + 0.5	V
Transient isolation voltage <sup>(2)</sup>	AC voltage, t = 60s <sup>(3)</sup>		570	V <sub>RMS</sub>
	DC voltage, t = 60s <sup>(3)</sup>		800	V <sub>DC</sub>
Input current	Continuous, any pin except power-supply pins	-10	10	mA
Temperature	Junction, T <sub>J</sub>		150	°C
	Storage, T <sub>stg</sub>	-65	150	

- (1) Operation outside the *Absolute Maximum Ratings* may cause permanent device damage. *Absolute Maximum Ratings* do not imply functional operation of the device at these or any other conditions beyond those listed under *Recommended Operating Conditions*. If used outside the Recommended Operating Conditions but within the Absolute Maximum Ratings, the device may not be fully functional, and this may affect device reliability, functionality, performance, and shorten the device lifetime.
- (2) Common-mode from left-side (pins1-4) to right-side (pins5-8) of the package.
- (3) Cumulative.

### 5.2 ESD Ratings

			VALUE	UNIT
V <sub>(ESD)</sub>	Electrostatic discharge	Human-body model (HBM), per ANSI/ESDA/JEDEC JS-001 <sup>(1)</sup>	±2000	V
		Charged-device model (CDM), per per ANSI/ESDA/JEDEC JS-002 <sup>(2)</sup>	±1000	

- (1) JEDEC document JEP155 states that 500V HBM allows safe manufacturing with a standard ESD control process.
- (2) JEDEC document JEP157 states that 250V CDM allows safe manufacturing with a standard ESD control process.

### 5.3 Recommended Operating Conditions

over operating ambient temperature range (unless otherwise noted)

			MIN	NOM	MAX	UNIT
<b>POWER SUPPLY</b>						
AVDD	Hgh-side power supply	AVDD to AGND	3	5.0	5.5	V
DVDD	Low-side power supply	DVDD to DGND	2.7	3.3	5.5	V
<b>ANALOG INPUT</b>						
V <sub>Clipping</sub>	Differential input voltage before clipping output	$V_{IN} = V_{INP} - V_{INN}$	±320			mV
V <sub>FSR</sub>	Specified linear differential input voltage	$V_{IN} = V_{INP} - V_{INN}$	-250		250	mV
V <sub>CM</sub>	Operating common-mode input voltage	$(V_{INP} + V_{INN}) / 2$ to AGND	-0.16	1		V
C <sub>IN, EXT</sub>	Minimum external capacitance connected to the input	from INP to INN	10			nF
<b>DIGITAL I/O</b>						
V <sub>IO</sub>	Digital input/output voltage		0		DVDD	V
f <sub>CLKIN</sub>	Input clock frequency		5	20	21	MHz
t <sub>HIGH</sub>	Input clock high time		21.5	50	110	ns
t <sub>LOW</sub>	Input clock low time		21.5	50	110	ns
<b>ISOLATION BARRIER</b>						
V <sub>LOWM</sub>	Functional isolation working voltage <sup>(1)</sup>	AC voltage (sine wave)			200	V <sub>RMS</sub>
		DC voltage			280	V <sub>DC</sub>
<b>TEMPERATURE RANGE</b>						
T <sub>A</sub>	Specified ambient temperature		-40		125	°C

(1) Common-mode from left-side (pins1-4) to right-side (pins5-8) of the package.

## 5.4 Thermal Information (DEN Package)

THERMAL METRIC <sup>(1)</sup>		DEN (VSON)	UNIT
		8 PINS	
R <sub>θJA</sub>	Junction-to-ambient thermal resistance	64.7	°C/W
R <sub>θJC(top)</sub>	Junction-to-case (top) thermal resistance	53.7	°C/W
R <sub>θJB</sub>	Junction-to-board thermal resistance	29.6	°C/W
Ψ <sub>JT</sub>	Junction-to-top characterization parameter	10.1	°C/W
Ψ <sub>JB</sub>	Junction-to-board characterization parameter	29.4	°C/W
R <sub>θJC(bot)</sub>	Junction-to-case (bottom) thermal resistance	23.4	°C/W

(1) For more information about traditional and new thermal metrics, see the [Semiconductor and IC Package Thermal Metrics](#) application note.

## 5.5 Package Characteristics

PARAMETER		TEST CONDITIONS	VALUE	UNIT
<b>DEN PACKAGE</b>				
CLR	External clearance	Shortest pin-to-pin distance through air	≥ 1	mm
CPG	External creepage	Shortest pin-to-pin distance across the package surface	≥ 1	mm
CTI	Comparative tracking index	DIN EN 60112 (VDE 0303-11); IEC 60112	≥ 600	V
	Material group	According to IEC 60664-1	I	
C <sub>IO</sub>	Capacitance, input to output <sup>(1)</sup>	V <sub>IO</sub> = 0.5 V <sub>PP</sub> at 1MHz	~1.5	pF
R <sub>IO</sub>	Resistance, input to output <sup>(1)</sup>	T <sub>A</sub> = 25°C	> 10 <sup>12</sup>	Ω

(1) All pins on each side of the barrier are tied together, creating a two-pin device.

## 5.6 Electrical Characteristics

minimum and maximum specifications are at  $T_A = -40^\circ\text{C}$  to  $125^\circ\text{C}$ ,  $AVDD = 3.0\text{V}$  to  $5.5\text{V}$ ,  $DVDD = 2.7\text{V}$  to  $5.5\text{V}$ ,  $V_{INP} = -250\text{mV}$  to  $250\text{mV}$ ,  $V_{INN} = 0\text{V}$ , and sinc<sup>3</sup> filter with OSR = 256 (unless otherwise noted); typical specifications are at  $T_A = 25^\circ\text{C}$ ,  $CLKIN = 20\text{MHz}$ ,  $AVDD = 5\text{V}$ , and  $DVDD = 3.3\text{V}$

PARAMETER		TEST CONDITIONS	MIN	TYP	MAX	UNIT
<b>ANALOG INPUTS</b>						
$C_{IN}$	Effective input sampling capacitance			2		pF
$R_{IN}$	Input impedance	$f_{CLK} = 10\text{MHz}$	TBD	50	TBD	k $\Omega$
		$f_{CLK} = 20\text{MHz}$	TBD	25	TBD	
$I_{INP}$	Input current	$V_{IN} = (V_{INP} - V_{INN}) = V_{FSR, MAX}$ , $f_{CLK} = 10\text{MHz}$	TBD	5	TBD	$\mu\text{A}$
		$V_{IN} = (V_{INP} - V_{INN}) = V_{FSR, MAX}$ , $f_{CLK} = 20\text{MHz}$	TBD	10	TBD	
$I_{INN}$	Input current	$V_{IN} = (V_{INP} - V_{INN}) = V_{FSR, MAX}$ , $f_{CLK} = 10\text{MHz}$	-TBD	-5	-TBD	$\mu\text{A}$
		$V_{IN} = (V_{INP} - V_{INN}) = V_{FSR, MAX}$ , $f_{CLK} = 20\text{MHz}$	-TBD	-10	-TBD	
CMTI	Common-mode transient immunity		150			V/ns
$E_O$	Offset error <sup>(1)</sup>	INP = INN = AGND, $T_A = 25^\circ\text{C}$	-200	$\pm 4.5$	200	$\mu\text{V}$
$E_G$	Gain error	$T_A = 25^\circ\text{C}$	-0.2%	$\pm 0.005\%$	0.2%	
$E_O$	Offset error <sup>(1)</sup>	INP = INN = AGND, $T_A = 25^\circ\text{C}$	-200	$\pm 4.5$	200	$\mu\text{V}$
$E_G$	Gain error	$T_A = 25^\circ\text{C}$	-0.2%	$\pm 0.005\%$	0.2%	
<b>DC ACCURACY</b>						
$E_O$	Offset error <sup>(1)</sup>	INP = INN = AGND, $T_A = 25^\circ\text{C}$	-200	$\pm 4.5$	200	$\mu\text{V}$
$TCE_O$	Offset error temperature drift <sup>(3)</sup>		-3		3	$\mu\text{V}/^\circ\text{C}$
$E_G$	Gain error	$T_A = 25^\circ\text{C}$	-0.2%	$\pm 0.005\%$	0.2%	
$TCE_G$	Gain error temperature drift <sup>(4)</sup>		-40	$\pm 20$	40	ppm/ $^\circ\text{C}$
INL	Integral nonlinearity <sup>(2)</sup>	Resolution: 16 bits	-4	$\pm 1$	4	LSB
DNL	Differential nonlinearity	Resolution: 16 bits	-0.99		0.99	LSB
CMRR	Common-mode rejection ratio	INP = INN, $f_{IN} = 0\text{Hz}$ , $V_{CM min} \leq V_{IN} \leq V_{CM max}$		-92		dB
		INP = INN, $f_{IN}$ from 0.1Hz to 10 kHz, $V_{CM min} \leq V_{IN} \leq V_{CM max}$		-95		
PSRR	Power-supply rejection ratio	INP = INN = AGND, AVDD from 3.0V to 5.5V, DC		-80		dB
		INP = INN = AGND, AVDD from 3.0V to 5.5V, 10kHz / 100mV ripple		-80		
<b>AC ACCURACY</b>						
SNR	Signal-to-noise ratio	$f_{IN} = 1\text{kHz}$		86		dB
SINAD	Signal-to-noise + distortion	$f_{IN} = 1\text{kHz}$		85.7		dB
THD	Total harmonic distortion <sup>(5)</sup>	$4.5\text{V} \leq AVDD \leq 5.5\text{V}$ , $f_{IN} = 1\text{kHz}$ , $5\text{MHz} \leq f_{CLKIN} \leq 21\text{MHz}$		-90		dB
		$3.0\text{V} \leq AVDD \leq 3.6\text{V}$ , $f_{IN} = 1\text{kHz}$ , $5\text{MHz} \leq f_{CLKIN} \leq 21\text{MHz}$		-93		
<b>CMOS LOGIC WITH SCHMITT-TRIGGER</b>						
$I_{IN}$	Input current	$DGND \leq V_{IN} \leq DVDD$	0		7	$\mu\text{A}$
$C_{IN}$	Input capacitance			4		pF
$V_{IH}$	High-level input voltage		$0.7 \times DVDD$		$DVDD + 0.3$	V

## 5.6 Electrical Characteristics (続き)

minimum and maximum specifications are at  $T_A = -40^\circ\text{C}$  to  $125^\circ\text{C}$ ,  $AVDD = 3.0\text{V}$  to  $5.5\text{V}$ ,  $DVDD = 2.7\text{V}$  to  $5.5\text{V}$ ,  $V_{INP} = -250\text{mV}$  to  $250\text{mV}$ ,  $V_{INN} = 0\text{V}$ , and sinc<sup>3</sup> filter with  $OSR = 256$  (unless otherwise noted); typical specifications are at  $T_A = 25^\circ\text{C}$ ,  $CLKIN = 20\text{MHz}$ ,  $AVDD = 5\text{V}$ , and  $DVDD = 3.3\text{V}$

PARAMETER		TEST CONDITIONS	MIN	TYP	MAX	UNIT
$V_{IL}$	Low-level input voltage		-0.3		$0.3 \times DVDD$	V
$C_{LOAD}$	Output load capacitance			30		pF
$V_{OH}$	High-level output voltage	$I_{OH} = -4\text{mA}$	$DVDD - 0.4$			V
$V_{OL}$	Low-level output voltage	$I_{OL} = 4\text{mA}$			0.4	V
<b>POWER SUPPLY</b>						
$I_{AVDD}$	High-side supply current			6.2	8.8	mA
$I_{DVDD}$	Low-side supply current	$C_{LOAD} = 15\text{pF}$		4.2	6.3	mA
$AVDD_{UV}$	High-side undervoltage detection threshold	AVDD rising	2.3	2.55	2.75	V
		AVDD falling	2.15	2.35	2.55	
$DVDD_{UV}$	Low-side undervoltage detection threshold	DVDD rising	2.3	2.55	2.75	V
		DVDD falling	2.15	2.35	2.55	

- (1) This parameter is input referred.
- (2) Integral nonlinearity is defined as the maximum deviation from a straight line passing through the end-points of the ideal ADC transfer function expressed as number of LSBs or as a percent of the specified linear full-scale range FSR.
- (3) Offset error temperature drift is calculated using the box method, as described by the following equation:  
 $TCE_O = (E_{O,MAX} - E_{O,MIN}) / TempRange$  where  $E_{O,MAX}$  and  $E_{O,MIN}$  refer to the maximum and minimum  $E_O$  values measured within the temperature range ( $-40$  to  $125^\circ\text{C}$ ).
- (4) Gain error temperature drift is calculated using the box method, as described by the following equation:  
 $TCE_G (ppm) = ((E_{G,MAX} - E_{G,MIN}) / TempRange) \times 10^4$  where  $E_{G,MAX}$  and  $E_{G,MIN}$  refer to the maximum and minimum  $E_G$  values (in %) measured within the temperature range ( $-40$  to  $125^\circ\text{C}$ ).
- (5) THD is the ratio of the rms sum of the amplitudes of first five higher harmonics to the amplitude of the fundamental.



### 5.7 Switching Characteristics

PARAMETER		TEST CONDITIONS	MIN	TYP	MAX	UNIT
$t_H$	DOUT hold time after rising edge of CLKIN	$C_{LOAD} = 15pF$	10			ns
$t_D$	Rising edge of CLKIN to DOUT valid delay	$C_{LOAD} = 15pF$			35	ns
$t_r$	DOUT rise time	10% to 90%, $2.7V \leq DVDD \leq 3.6V$ , $C_{LOAD} = 15pF$		3.8	7	ns
		10% to 90%, $4.5V \leq DVDD \leq 5.5V$ , $C_{LOAD} = 15pF$		4.3	7	
$t_f$	DOUT fall time	10% to 90%, $2.7V \leq DVDD \leq 3.6V$ , $C_{LOAD} = 15pF$		3.8	7	ns
		10% to 90%, $4.5V \leq DVDD \leq 5.5V$ , $C_{LOAD} = 15pF$		4.3	7	
$t_{START}$	Device start-up time	AVDD step from 0 to 3.0V with AVDD $\geq 2.7V$ to bitstream valid, 0.1% settling		0.5		ms

### 5.8 Timing Diagrams



図 5-1. Digital Interface Timing



図 5-2. Device Start-Up Timing

## 6 Detailed Description

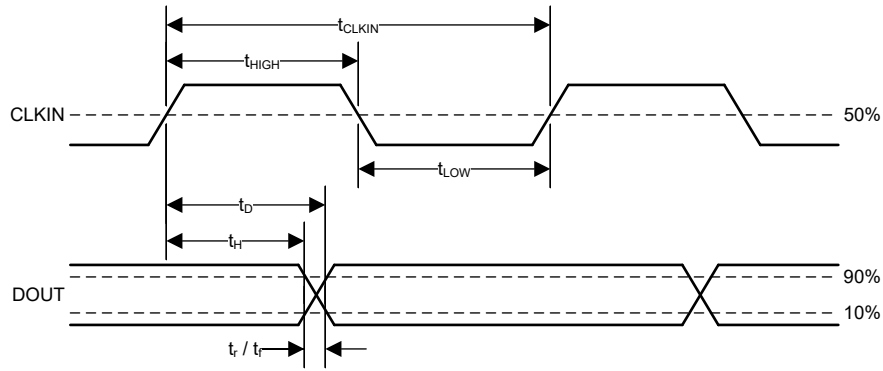
### 6.1 Overview

The AMC0106M25 is a single-channel, second-order, CMOS, delta-sigma ( $\Delta\Sigma$ ) modulator designed for high-resolution analog-to-digital conversions of AC signals. The differential analog input of the AMC0106M25 is implemented with a switched-capacitor circuit. The isolated output of the converter (DOUT) provides a stream of digital ones and zeros synchronous to the external clock applied to the CLKIN pin. The time average of this serial output is proportional to the analog input voltage.

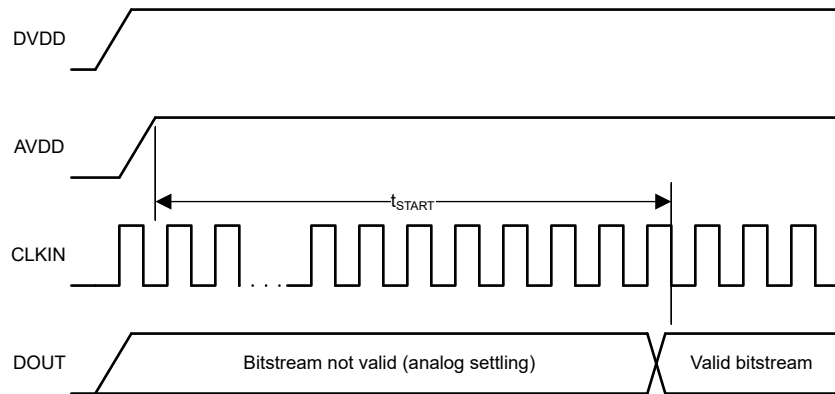
The modulator shifts the quantization noise to high frequencies. Therefore, use a digital low-pass digital filter, such as a sinc filter at the device output to increase overall performance. This filter also converts from the 1-bit data stream at a high sampling rate into a higher-bit data word at a lower rate (decimation). Use a microcontroller ( $\mu\text{C}$ ) or field-programmable gate array (FPGA) to implement the filter.

The overall performance (speed and resolution) depends on the selection of an appropriate oversampling ratio (OSR) and filter type. A higher OSR results in higher resolution while operating at a lower refresh rate. A lower OSR results in lower resolution, but provides data at a higher refresh rate. Multiple filters can run in parallel. For example, a low OSR filter for fast overcurrent detection and a high OSR filter for high resolution current measurement.

The silicon-dioxide ( $\text{SiO}_2$ ) based capacitive isolation barrier supports a high level of magnetic field immunity; see the [ISO72x Digital Isolator Magnetic-Field Immunity application note](#). The AMC0106M25 uses an on-off keying (OOK) modulation scheme to transmit data across the isolation barrier. This modulation, and the isolation barrier characteristics, result in high reliability in noisy environments and high common-mode transient immunity.

### 6.2 Functional Block Diagram

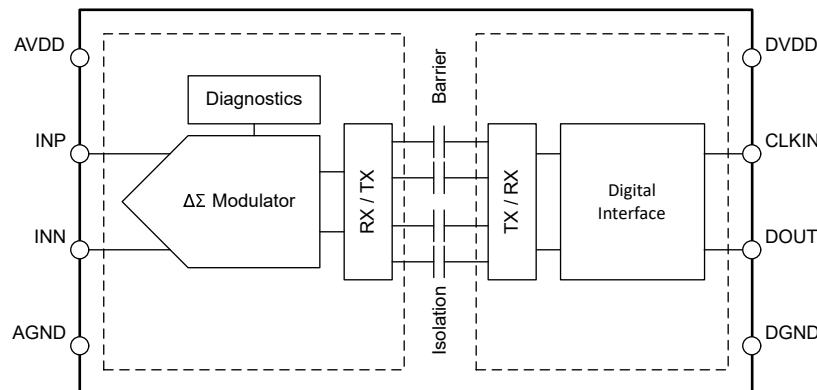

## 6.3 Feature Description

### 6.3.1 Analog Input

As shown in [Figure 6-1](#), the input of the AMC0106M25 is a fully differential, switched-capacitor circuit with a dynamic input impedance of 25kΩ at 20MHz.

The sampling capacitor is continuously charged and discharged with a frequency of  $f_{CLK}$ . With the S1 switches closed,  $C_{IND}$  charges to the voltage difference across  $V_{INP}$  and  $V_{INN}$ . For the discharge phase, both S1 switches open first and then both S2 switches close.  $C_{IND}$  discharges to approximately AGND + 0.8V during this phase.

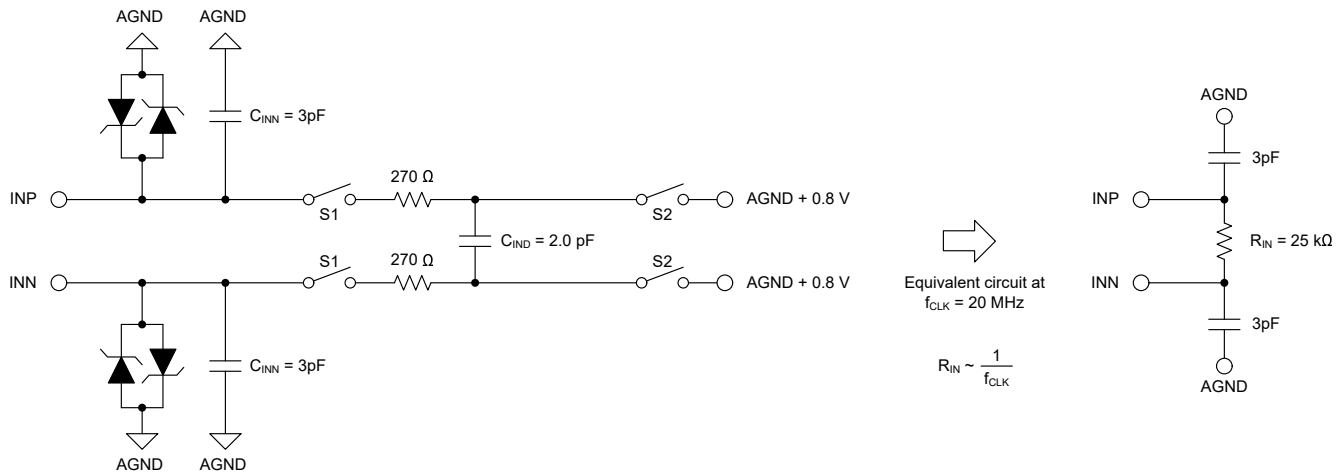

**Figure 6-1. Equivalent Input Circuit**

The analog input range is tailored to directly accommodate a voltage drop across a shunt resistor used for current sensing. There are two restrictions on the analog input signals (INP and INN). First, if the input voltage exceeds the input range specified in the [絶対最大定格](#) table, limit the input current to the absolute maximum value because the electrostatic discharge (ESD) protection turns on. Second, the linearity and noise performance of the device are specified only when the differential analog input voltage remains within the specified  $V_{FSR}$  and  $V_{CM}$  ranges.  $V_{FSR}$  is the linear full-scale range and  $V_{CM}$  is the input common-mode voltage range.

### 6.3.2 Modulator

Figure 6-2 conceptualizes the second-order, switched-capacitor, feed-forward  $\Delta\Sigma$  modulator implemented in the AMC0106M25. The output  $V_5$  of the 1-bit, digital-to-analog converter (DAC) is subtracted from the input voltage  $V_{IN} = (V_{INN} - V_{INP})$ . This subtraction provides an analog voltage  $V_1$  at the input of the first integrator stage. The output of the first integrator feeds the input of the second integrator stage. The result is an output voltage  $V_3$  that is summed with the input signal  $V_{IN}$  and the output of the first integrator  $V_2$ . Depending on the polarity of the resulting voltage  $V_4$ , the output of the comparator is changed. In this case, the 1-bit DAC responds on the next clock pulse by changing the associated analog output voltage  $V_5$ . Thus, causing the integrators to progress in the opposite direction and forcing the integrator output value to track the average value of the input.

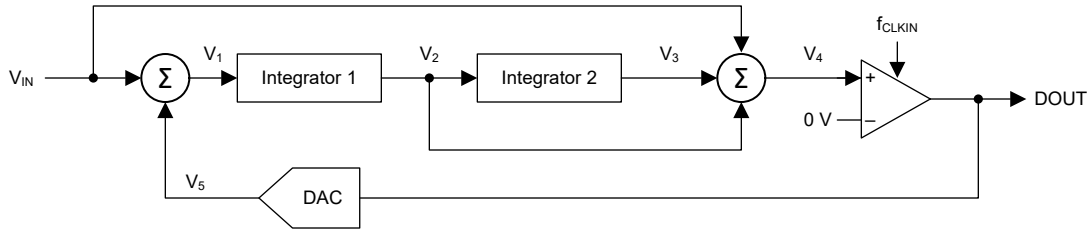

Figure 6-2. Block Diagram of a Second-Order Modulator

### 6.3.3 Isolation Channel Signal Transmission

The AMC0106M25 uses an on-off keying (OOK) modulation scheme to transmit the modulator output bitstream across the SiO<sub>2</sub>-based isolation barrier. The transmit driver (TX) illustrated in the [Functional Block Diagram](#) transmits an internally generated, high-frequency carrier across the isolation barrier to represent a digital one. However, TX does not send a signal to represent a digital zero. The nominal frequency of the carrier used inside the AMC0106M25 is 480MHz.

Figure 6-3 shows the concept of the on-off keying scheme.

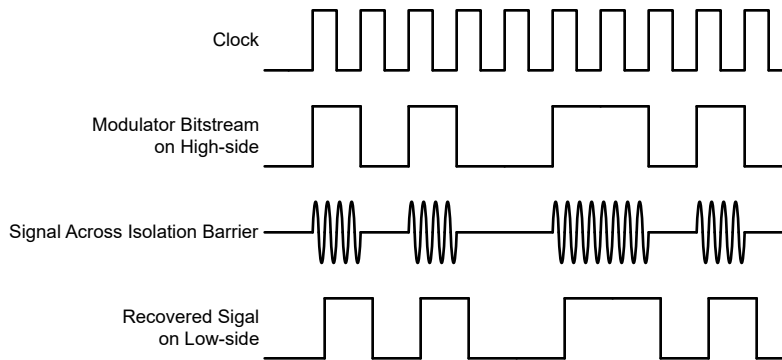
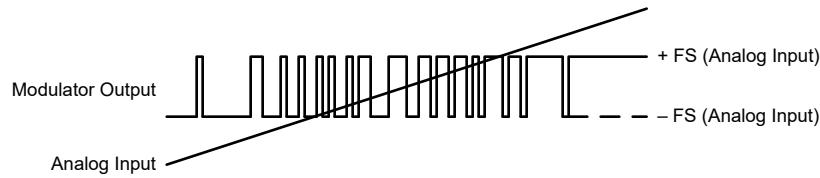

Figure 6-3. OOK-Based Modulation Scheme

### 6.3.4 Digital Output

A differential input signal of 0V ideally produces a stream of ones and zeros that is high 50% of the time. A differential input of 250mV produces a stream of ones and zeros that is high 89.06% of the time. With 16 bits of resolution, that percentage ideally corresponds to code 58368. A differential input of 250mV produces a stream of ones and zeros that are high 10.94% of the time. With 16 bits of resolution, that percentage ideally corresponds to code 7168. These input voltages are also the specified linear range of the AMC0106M25. If the input voltage value exceeds this range, the output of the modulator shows increasing nonlinear behavior as the quantization noise increases. The modulator output clips with a constant stream of zeros with an input  $\leq 320\text{mV}$  or with a constant stream of ones with an input  $\geq 320\text{mV}$ . In this case, however, the AMC0106M25 generates a single 1 or 0 every 128 clock cycles to indicate proper device function. A single 1 is generated if the input is at negative full-scale and a 0 is generated if the input is at positive full-scale. See the [Output Behavior in Case of a Full-Scale Input](#) section for more details. [Figure 6-4](#) shows the input voltage versus the output modulator signal.



**Figure 6-4. Modulator Output vs Analog Input**

The density of ones in the output bitstream is calculated using [Equation 1](#) for any input voltage ( $V_{IN} = V_{INP} - V_{INN}$ ) value. Except for a full-scale input signal, as described in [Output Behavior in Case of a Full-Scale Input](#) section.

$$\rho = \frac{V_{IN} + V_{Clipping}}{2 \times V_{Clipping}} \quad (1)$$

#### 6.3.4.1 Output Behavior in Case of a Full-Scale Input

If a full-scale input signal is applied to the AMC0106M25, the device generates a single one or zero every 128 bits at DOUT. [Figure 6-5](#) shows a timing diagram of this process. A single 1 or 0 is generated depending on the actual polarity of the signal being sensed. A full-scale signal is defined when  $|V_{IN}| \geq |V_{Clipping}|$ . In this way, differentiating between a missing AVDD and a full-scale input signal is possible on the system level.

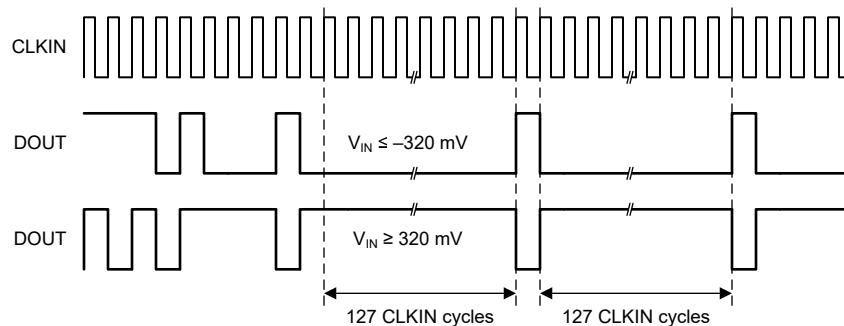

**Figure 6-5. Full-Scale Output of the AMC0106M25**

### 6.3.4.2 Output Behavior in Case of a Missing High-Side Supply

As shown in [Figure 6-6](#), the device provides a constant bitstream of logic 0's at the output if the high-side supply is missing. DOUT is permanently low when the high-side supply is missing. A one is not generated every 128 clock pulses, which differentiates this condition from a valid negative full-scale input. This feature helps identify high-side power-supply problems on the board.



図 6-6. Output of the AMC0106M25 in Case of a Missing High-Side Supply

## 6.4 Device Functional Modes

The AMC0106M25 operates in one of the following states:

- OFF-state: The low-side of the device (AVDD) is not supplied. The device is not responsive and DOUT is in high-impedance state. Internally, DOUT is clamped to DVDD and DGND by ESD protection diodes.
- Missing high-side supply: DVDD is supplied within the [推奨動作条件](#) but  $V_{AVDD}$  is below the  $AVDD_{UV}$  threshold. The device outputs a constant bitstream of logic 0's as described in the [Output Behavior in Case of a Missing High-Side Supply](#) section.
- Common-mode input violation: AVDD and DVDD are supplied within the respective recommended operating conditions. However, the common-mode input voltage  $V_{CM} = (V_{INP} + V_{INN}) / 2$  is outside the recommended operating conditions. The device outputs invalid data, independent of the differential input voltage  $V_{IN}$ .
- Differential input voltage range violation (full-scale input):  $V_{AVDD}$ ,  $V_{DVDD}$ , and  $V_{CM}$  are within the recommended operating conditions. However, the differential input voltage  $V_{IN} = (V_{INP} - V_{INN})$  exceeds the clipping voltage ( $|V_{IN}| > |V_{Clipping}|$ ). The device outputs a fixed pattern as described in the [Output Behavior in Case of a Missing High-Side Supply](#) section.
- Normal operation:  $V_{AVDD}$ ,  $V_{DVDD}$ ,  $V_{CM}$ , and  $V_{IN}$  are within the recommended operating conditions. The device outputs a digital bitstream as explained in the [Digital Output](#) section.

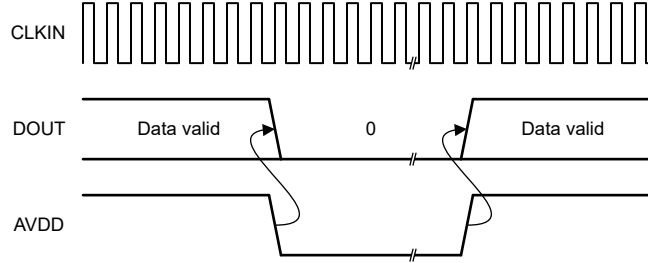
表 6-1. Device Operational Modes

OPERATING CONDITION	$V_{DVDD}$	$V_{AVDD}$	$V_{CM}$ ( $V_{INP} + V_{INN}$ ) / 2	$V_{IN}$ ( $V_{INP} - V_{INN}$ )	DEVICE RESPONSE
OFF	$V_{DVDD} < DVDD_{UV}$	Don't care	Don't care	Don't care	DOUT is in Hi-Z state. DOUT is clamped to DVDD and DGND by ESD protection diodes.
Missing high-side supply	Valid <sup>(1)</sup>	$V_{AVDD} < AVDD_{UV}$	Don't care	Don't care	DOUT is constantly low
Common-mode input voltage range violation	Valid <sup>(1)</sup>	Valid <sup>(1)</sup>	$V_{CM} < V_{CM, MIN}$ or $V_{CM} > V_{CM, MAX}$	Don't care	Device outputs invalid data
Differential input voltage range violation	Valid <sup>(1)</sup>	Valid <sup>(1)</sup>	Valid <sup>(1)</sup>	$ V_{IN}  > V_{Clipping}$	Device outputs a single 1 or a single 0 every 128 <sup>th</sup> clock cycle
Normal operation	Valid <sup>(1)</sup>	Valid <sup>(1)</sup>	Valid <sup>(1)</sup>	Valid <sup>(1)</sup>	Normal Operation

(1) Valid means within recommended operating conditions.

## 7 Application and Implementation

注

Information in the following applications sections is not part of the TI component specification, and TI does not warrant its accuracy or completeness. TI's customers are responsible for determining suitability of components for their purposes, as well as validating and testing their design implementation to confirm system functionality.

### 7.1 Application Information

Isolated modulators are widely used in application where a high-voltage domain is galvanically isolated from a low-voltage domain for safety or functional reasons. A typical application is the sensing of the phase currents in a frequency inverter.

### 7.2 Typical Application

Figure 7-1 shows a simplified schematic of a full-bridge motor drive that uses an AMC0106M25 to sense the motor current. The current flowing through an external shunt resistor RSHUNT produces a voltage drop that is sensed by the AMC0106M25. The AMC0106M25 digitizes the analog input signal on the high-side and transfers the data across the isolation barrier to the low-side. The device then outputs the digital bitstream on the DOUT pin that is synchronized to the clock applied to the CLKIN pin. The digital bitstream is processed by a low-pass digital filter in a micro control unit (MCU) or FPGA.

The 48V DC link voltage in this application is sensed by an AMC0136 isolated modulator.

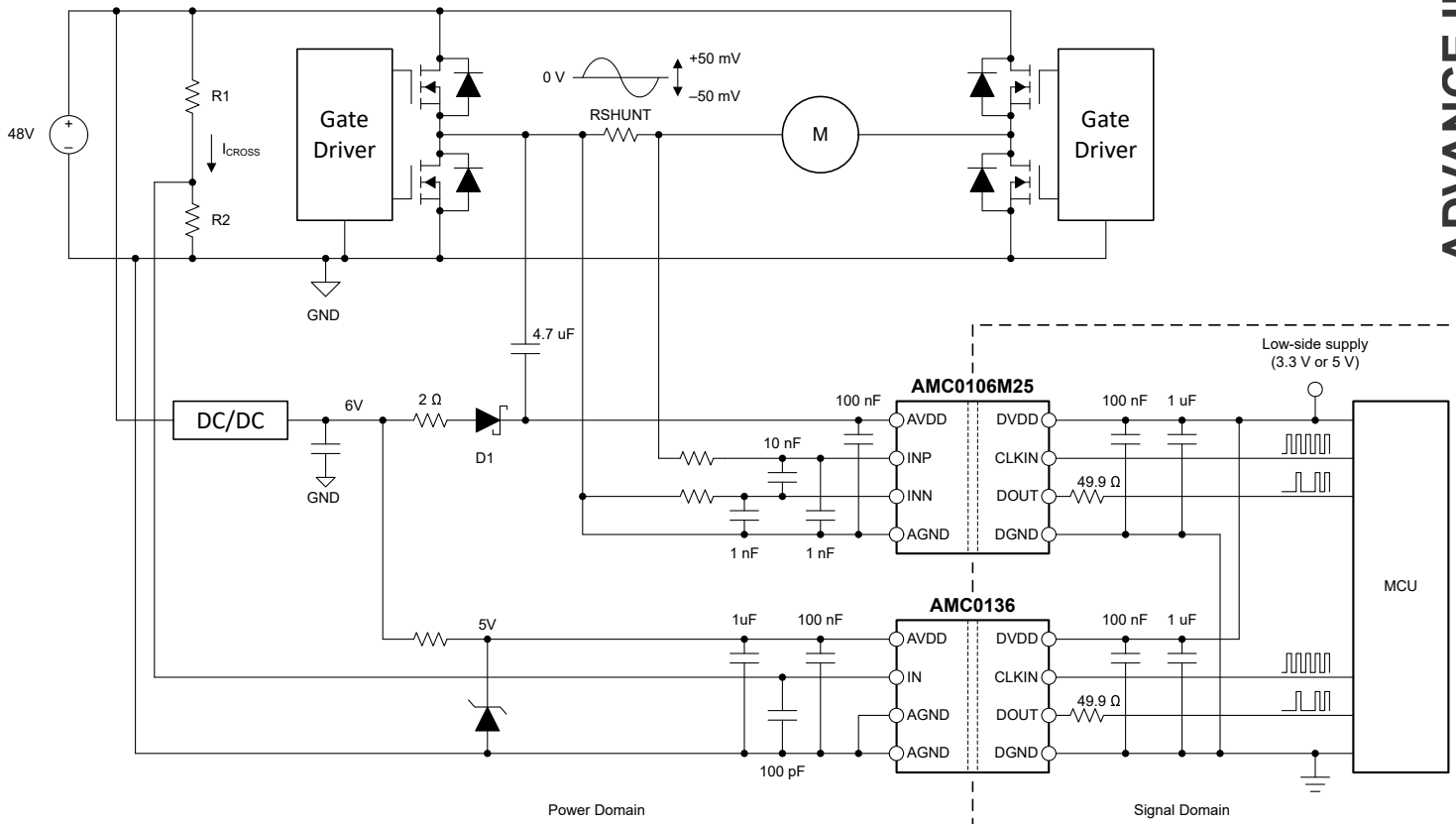

Figure 7-1. Using the AMC0106M25 for Current Sensing in a Full-Bridge 48V Motor Driver Design

ADVANCE INFORMATION

The high-side power supply (AVDD) is generated from a bootstrap circuit (R4, D1, C2). The low-side supply is shared with circuitry in the signal domain. Use the optional 49.9Ω resistor on the DOUT pin for line-termination to improve signal integrity on the receiving end.

The galvanic isolation barrier and high common-mode transient immunity (CMTI) of the AMC0106M25 provide reliable and accurate operation even in high-noise environments.

### 7.2.1 Design Requirements

表 7-1 lists the parameters for this typical application.

表 7-1. Design Requirements

PARAMETER	VALUE
System voltage, power-stage	48V
Bootstrap supply voltage (V <sub>BS</sub> )	6V
Maximum ripple voltage on AVDD supply (V <sub>RIPPLE</sub> )	200mV
PWM frequency	16kHz
PWM duty cycle range	5% to 95%
Linear current sensing range	±5A

### 7.2.2 Detailed Design Procedure

In 図 7-1, the high-side power supply (AVDD) is generated from a bootstrap circuit (R4, D1, C2).

The high-side ground reference (AGND) is derived from the end of the shunt resistor connected to the negative input of the AMC0106M25 (INN). For a four-terminal shunt, connect the device inputs to the inner leads of the shunt and connect AGND to the outer leads. To minimize offset and improve accuracy, route the ground connection as a separate trace. Connect AGND directly to the shunt resistor rather than shorting AGND to INN at the input to the device. See the [Layout](#) section for more details.

#### 7.2.2.1 Shunt Resistor Sizing

The shunt resistor (RSHUNT) value is determined by the device linear input voltage range (±250mV) and the desired linear current sensing range of ±5A. RSHUNT is calculated as  $250\text{mV} / 5\text{A} = 50\text{m}\Omega$ . The peak power dissipated in the shunt resistor is  $R_{\text{SHUNT}} \times I_{\text{PEAK}}^2 = 50\text{m}\Omega \times (5\text{A})^2 = 1.25\text{W}$ . For a linear response, operate the shunt resistor at no more than 2/3 of the rated power. Therefore, a shunt resistor with a nominal power rating of approximately 1.8W is selected.

Select a lower shunt resistor value if transient overcurrents are expected in the system that exceed the linear input voltage range of the AMC0106M25. However, if reduced linearity and lower resolution is acceptable for the overcurrent range, allow the voltage drop across the shunt to exceed the linear input voltage range up to the clipping voltage of the AMC0106M25. In any case, make sure the voltage drop caused by the maximum overcurrent does not exceed the input voltage that causes a clipping output. That is, make sure  $|V_{\text{SHUNT}}| \leq |V_{\text{Clipping}}|$ .



### 7.2.2.2 Input Filter Design

Place a differential RC filter (R1, R2, C5) in front of the isolated modulator to improve signal-to-noise performance of the signal path. Input noise with a frequency close to the  $\Delta\Sigma$  modulator sampling frequency (typically 20MHz) is folded back into the low-frequency range by the modulator. The purpose of the RC filter at the input is to attenuate high-frequency noise below the desired noise level of the measurement. Design the input filter such that:

- The filter capacitance (C5) is a minimum of 10nF
- The cutoff frequency of the filter is at least one order of magnitude lower than the sampling frequency ( $f_{CLKIN}$ ) of the  $\Delta\Sigma$  modulator
- The dynamic input bias current does not generate significant voltage drop across the DC impedances (R1, R2) of the input filter
- The impedances measured from the analog inputs are equal (R1 equals R2)

Capacitors C6 and C7 are optional and improve common-mode rejection at high frequencies (>1MHz). For best performance, make sure C6 matches the value of C7 and that both capacitors are 10 to 20 times lower in value than C5. NP0-type capacitors offer low temperature drift and low voltage coefficients, and are preferred for common-mode filtering. For most applications, the structure shown in [Figure 7-2](#) achieves excellent performance.

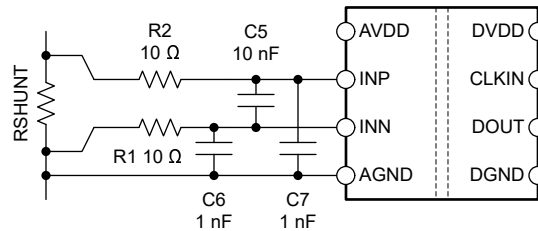

Figure 7-2. Input Filter

### 7.2.2.3 Bitstream Filtering

The modulator generates a bitstream that is processed by a digital filter to obtain a digital word similar to a conversion result of a conventional analog-to-digital converter (ADC). [Equation 2](#) shows a sinc<sup>3</sup>-type filter, which is a very simple filter built with minimal effort and hardware.

$$H(z) = \left( \frac{1 - z^{-OSR}}{1 - z^{-1}} \right)^3 \quad (2)$$

This filter provides the best output performance at the lowest hardware size (count of digital gates) for a second-order modulator. All characterization in this document is done with a sinc<sup>3</sup> filter with an oversampling ratio (OSR) of 256 and a 16-bit output word width.

The [Combining the ADS1202 with an FPGA Digital Filter for Current Measurement in Motor Control Applications application note](#) discusses an example code. Use this example code for implementing a sinc<sup>3</sup> filter in an FPGA. This application note is available for download at [www.ti.com](http://www.ti.com).

For modulator output bitstream filtering, use a device from TI's C2000 or Sitara microcontroller families. These families support multichannel dedicated hardwired filter structures that significantly simplify system level design by offering two filtering paths per channel. One path provides high-accuracy results for the control loop and the other provides a fast-response path for overcurrent detection.

A [delta sigma modulator filter calculator](#) is available for download at [www.ti.com](http://www.ti.com) that aids in filter design and correct OSR and filter order selection. This calculator helps achieve the desired output resolution and filter response time.

### 7.2.2.4 Designing the Bootstrap Supply

The bootstrap capacitor (C2, [Figure 7-1](#)) is charged during the PWM on-time of the low-side FET of the left-hand-side half bridge. During the PWM off-time, C2 rises with the switch pin voltage and serves as the AMC0106M25 power supply. R4 serves as a current-limiting resistor during the charging phase, and D1 prevents reverse current from flowing back to the bootstrap supply during the discharge phase.

The voltage C2 charges up to during the PWM on-time depends on the values of the bootstrap supply and the current limiting resistor R2. Additionally, this voltage depends on the PWM duty cycle and the forward voltage of the diode D1 ( $V_{F, D1}$ ).

The voltage C2 discharges to during the PWM off-time depends on the reverse recovery time of D1. Additionally, this voltage depends on the PWM duty cycle and the current draw of the AMC0106M25 ( $I_{AVDD}$ ). To minimize switching losses, select a fast switching diode with high forward current capability.

Make sure C2 is sized to support the maximum  $I_{AVDD}$  current for the duration of the maximum PWM off-time. During this time, make sure C2 does not discharge below the minimum recommended AVDD voltage of 3V. Lower capacitance values allow faster charging and therefore support lower PWM duty cycles. However, lower values also generate more voltage ripple and limit the maximum PWM off time. In this example, a ripple voltage ( $V_{RIPPLE}$ ) of less than 200mV is targeted. The maximum PWM off-time is  $95\% \times (1 / f_{PWM}) = 0.95 \times 62.5\mu s$ , which is approximately 60 $\mu s$ .  $I_{AVDD, MAX}$  is specified as 8.8mA. The minimum capacitance value is calculated as  $C_{2, MIN} = I_{AVDD, MAX} \times t_{PWM-OFF, MAX} / V_{RIPPLE} = 8.8mA \times 60\mu s / 200mV = 2.6\mu F$ . A 4.7 $\mu F$  capacitor is selected to allow for component tolerances and adds margin to the design.

Make sure the bootstrap circuit supports recharging C2 within the minimum PWM on-time of  $5\% \times (1 / f_{PWM}) = 0.05 \times 62.5\mu s$ , or approximately 3.1 $\mu s$ . The average charging current during this time is  $C2 \times V_{RIPPLE} / t_{PWM-ON, MIN} = 4.7\mu F \times 200mV / 3.1\mu s$ , which is approximately 300mA. This current is the minimum forward current that diode D1 has to support. The maximum allowable voltage drop across diode D1 and current limiting resistor R4 is determined by the minimum capacitor voltage and the  $V_{BS}$  value. The minimum capacitor voltage is 3V and equivalent to  $AVDD_{MIN}$ .  $V_{BS}$  is the bootstrap supply voltage and is equal to 6V. Assume a diode forward voltage of 1V is used. Make sure R4 is  $< (V_{BS} - V_{F, D1} - V_{C2, MIN}) / I_{CHARGE} = (6V - 1V - 3V) / 300mA = 6\Omega$ . A 2 $\Omega$  resistor is selected to provide margin to the design.

## 7.3 Best Design Practices

Place a minimum 10nF capacitor at the device input (from INP to INN). This capacitor helps avoid voltage droop at the input during the sampling period of the switched-capacitor input stage.

Do not leave the inputs of the AMC0106M25 unconnected (floating) when the device is powered up. If either modulator input is left floating, the output bitstream is not valid.

Connect the high-side ground (AGND) to INN, either by a hard short or through a resistive path. A DC current path between INN and AGND is required to define the input common-mode voltage. Do not exceed the input common-mode range, as specified in the [推奨動作条件](#) table. For best accuracy, route the ground connection as a separate trace that connects directly to the sense resistor. Do not short AGND to INN directly at the device input. See the [Layout](#) section for more details.

## 7.4 Power Supply Recommendations

The AMC0106M25 does not require any specific power-up sequencing. The high-side power supply (AVDD) is decoupled with a low-ESR, 100nF capacitor (C1) parallel to a low-ESR, 1 $\mu$ F capacitor (C2). The low-side power supply (DVDD) is equally decoupled with a low-ESR, 100nF capacitor (C3) parallel to a low-ESR, 1 $\mu$ F capacitor (C4). Place all four capacitors (C1, C2, C3, and C4) as close to the device as possible. [Figure 7-3](#) shows a decoupling diagram for the AMC0106M25.

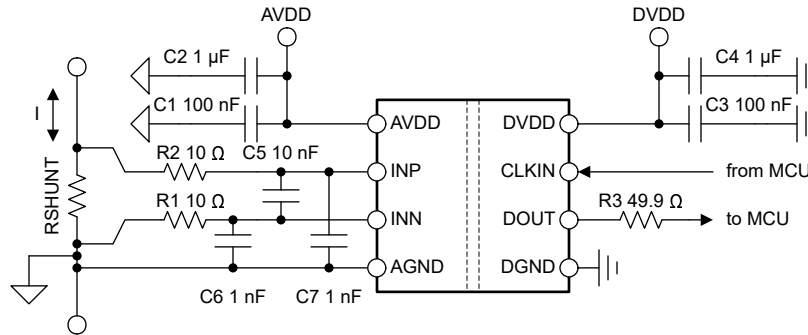

**Figure 7-3. Decoupling of the AMC0106M25**

Capacitors have to provide adequate effective capacitance under the applicable DC bias conditions that are experienced in the application. Multilayer ceramic capacitors (MLCC) typically exhibit only a fraction of the nominal capacitance under real-world conditions. Take this factor into consideration when selecting these capacitors. This problem is especially acute in low-profile capacitors, in which the dielectric field strength is higher than in taller components. Reputable capacitor manufacturers provide capacitance versus DC bias curves that greatly simplify component selection.

## 7.5 Layout

### 7.5.1 Layout Guidelines

The [Layout Example](#) section provides a layout recommendation with the critical placement of the decoupling capacitors (as close as possible to the AMC0106M25 supply pins). This section also depicts the placement of other components required by the device. For best performance, place the sense resistor close to the device input pins (INN and INP).

### 7.5.2 Layout Example

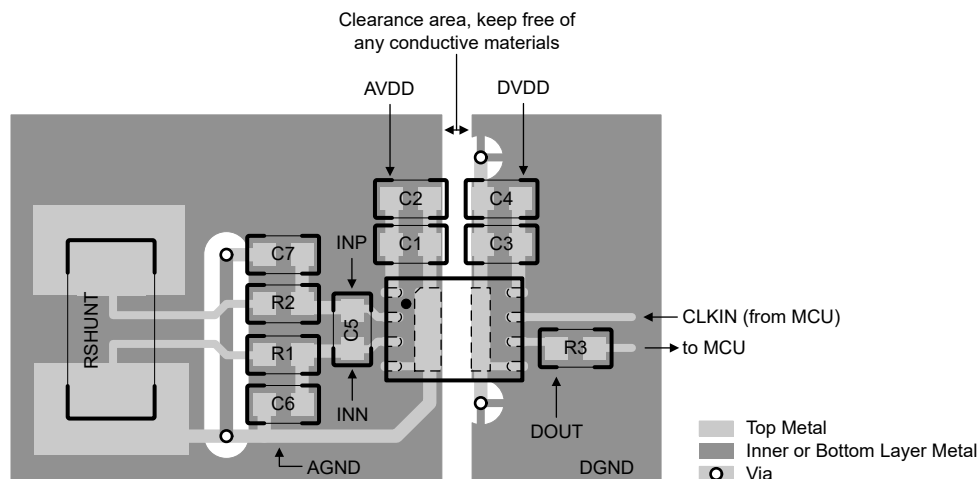

**Figure 7-4. Recommended Layout of the AMC0106M25**

## 8 Device and Documentation Support

### 8.1 Documentation Support

#### 8.1.1 Related Documentation

For related documentation see the following:

- Texas Instruments, [Isolation Glossary application note](#)
- Texas Instruments, [Semiconductor and IC Package Thermal Metrics application note](#)
- Texas Instruments, [ISO72x Digital Isolator Magnetic-Field Immunity application note](#)
- Texas Instruments, [Combining the ADS1202 with an FPGA Digital Filter for Current Measurement in Motor Control Applications application note](#)
- Texas Instruments, [Delta Sigma Modulator Filter Calculator design tool](#)

### 8.2 ドキュメントの更新通知を受け取る方法

ドキュメントの更新についての通知を受け取るには、[www.tij.co.jp](http://www.tij.co.jp) のデバイス製品フォルダを開いてください。[通知] をクリックして登録すると、変更されたすべての製品情報に関するダイジェストを毎週受け取ることができます。変更の詳細については、改訂されたドキュメントに含まれている改訂履歴をご覧ください。

### 8.3 サポート・リソース

テキサス・インスツルメンツ E2E™ サポート・フォーラムは、エンジニアが検証済みの回答と設計に関するヒントをエキスパートから迅速かつ直接得ることができる場所です。既存の回答を検索したり、独自の質問をしたりすることで、設計に必要な支援を迅速に得ることができます。

リンクされているコンテンツは、各寄稿者により「現状のまま」提供されるものです。これらはテキサス・インスツルメンツの仕様を構成するものではなく、必ずしもテキサス・インスツルメンツの見解を反映したものではありません。テキサス・インスツルメンツの[使用条件](#)を参照してください。

### 8.4 Trademarks

テキサス・インスツルメンツ E2E™ is a trademark of Texas Instruments.

すべての商標は、それぞれの所有者に帰属します。

### 8.5 静電気放電に関する注意事項



この IC は、ESD によって破損する可能性があります。テキサス・インスツルメンツは、IC を取り扱う際には常に適切な注意を払うことを推奨します。正しい取り扱いおよび設置手順に従わない場合、デバイスを破損するおそれがあります。

ESD による破損は、わずかな性能低下からデバイスの完全な故障まで多岐にわたります。精密な IC の場合、パラメータがわずかに変化するだけで公表されている仕様から外れる可能性があるため、破損が発生しやすくなっています。

### 8.6 用語集

[テキサス・インスツルメンツ用語集](#) この用語集には、用語や略語の一覧および定義が記載されています。

## 9 Revision History

資料番号末尾の英字は改訂を表しています。その改訂履歴は英語版に準じています。

DATE	REVISION	NOTES
August 2024	*	Initial Release

## 10 Mechanical, Packaging, and Orderable Information

The following pages include mechanical, packaging, and orderable information. This information is the most current data available for the designated devices. This data is subject to change without notice and revision of this document. For browser-based versions of this data sheet, refer to the left-hand navigation.

10.1 Mechanical Data

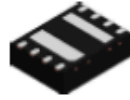

**DEN0008A**

**PACKAGE OUTLINE**

**VSON - 1 mm max height**

PLASTIC SMALL OUTLINE - NO LEAD

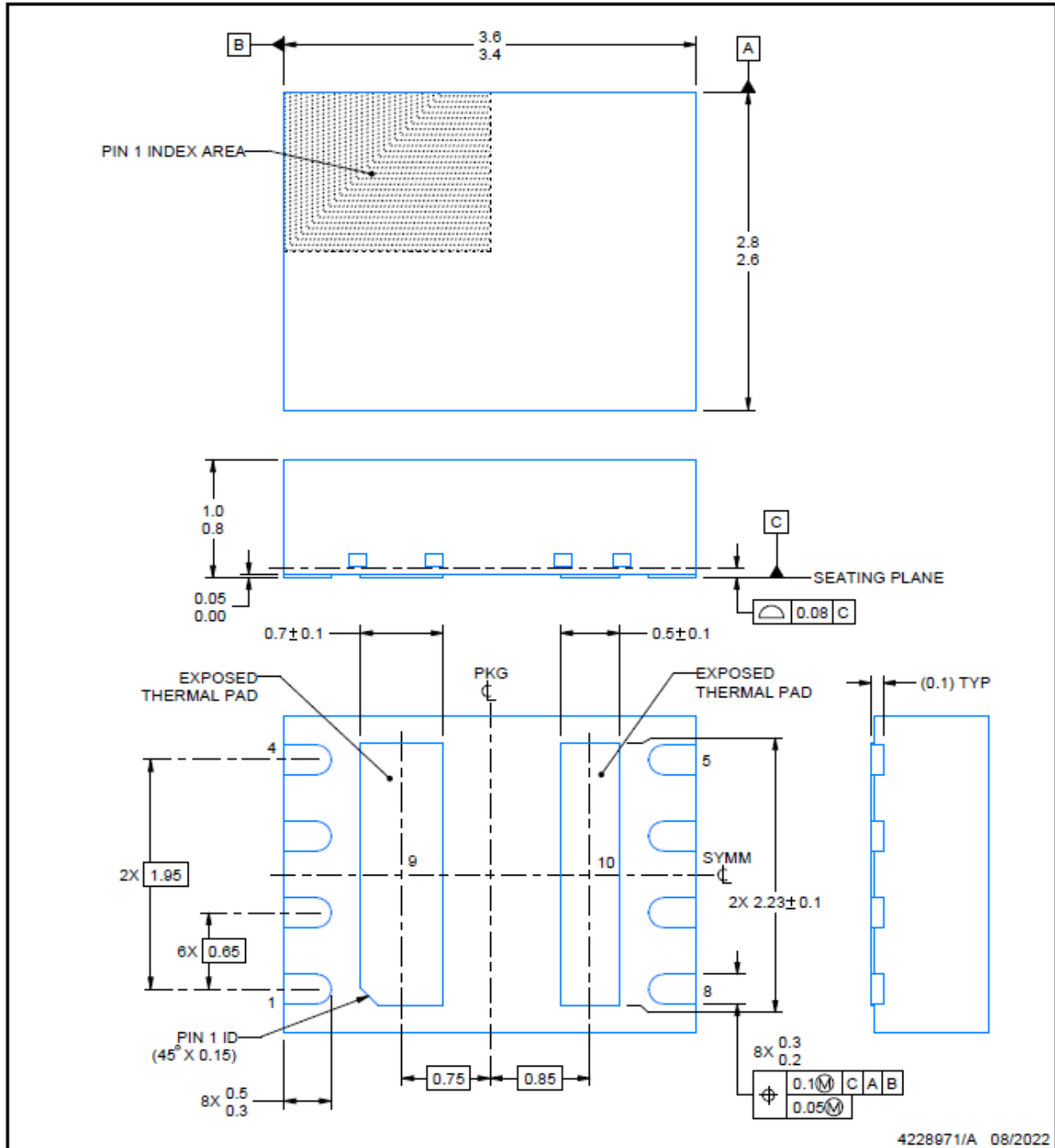

NOTES:

1. All linear dimensions are in millimeters. Any dimensions in parenthesis are for reference only. Dimensioning and tolerancing per ASME Y14.5M.
2. This drawing is subject to change without notice.
3. The package thermal pad must be soldered to the printed circuit board for thermal and mechanical performance.

ADVANCE INFORMATION

## EXAMPLE BOARD LAYOUT

**DEN0008A**

**VSON - 1 mm max height**

PLASTIC SMALL OUTLINE - NO LEAD

ADVANCE INFORMATION

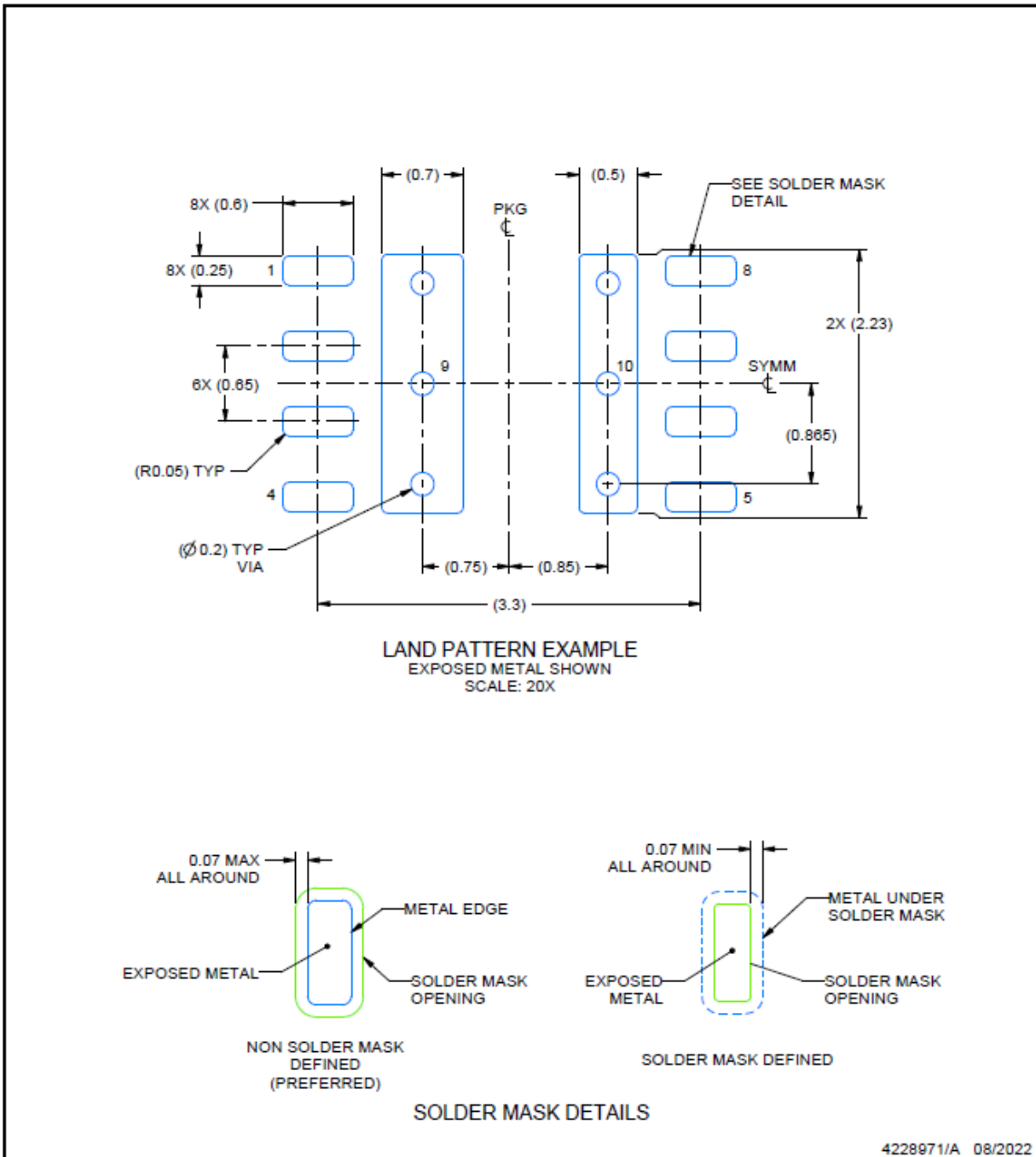

NOTES: (continued)

4. This package is designed to be soldered to a thermal pad on the board. For more information, see Texas Instruments literature number SLUA271 ([www.ti.com/lit/sluea271](http://www.ti.com/lit/sluea271)).
5. Vias are optional depending on application, refer to device data sheet. If any vias are implemented, refer to their locations shown on this view. It is recommended that vias under paste be filled, plugged or tented.

## EXAMPLE STENCIL DESIGN

**DEN0008A**

**VSON - 1 mm max height**

PLASTIC SMALL OUTLINE - NO LEAD

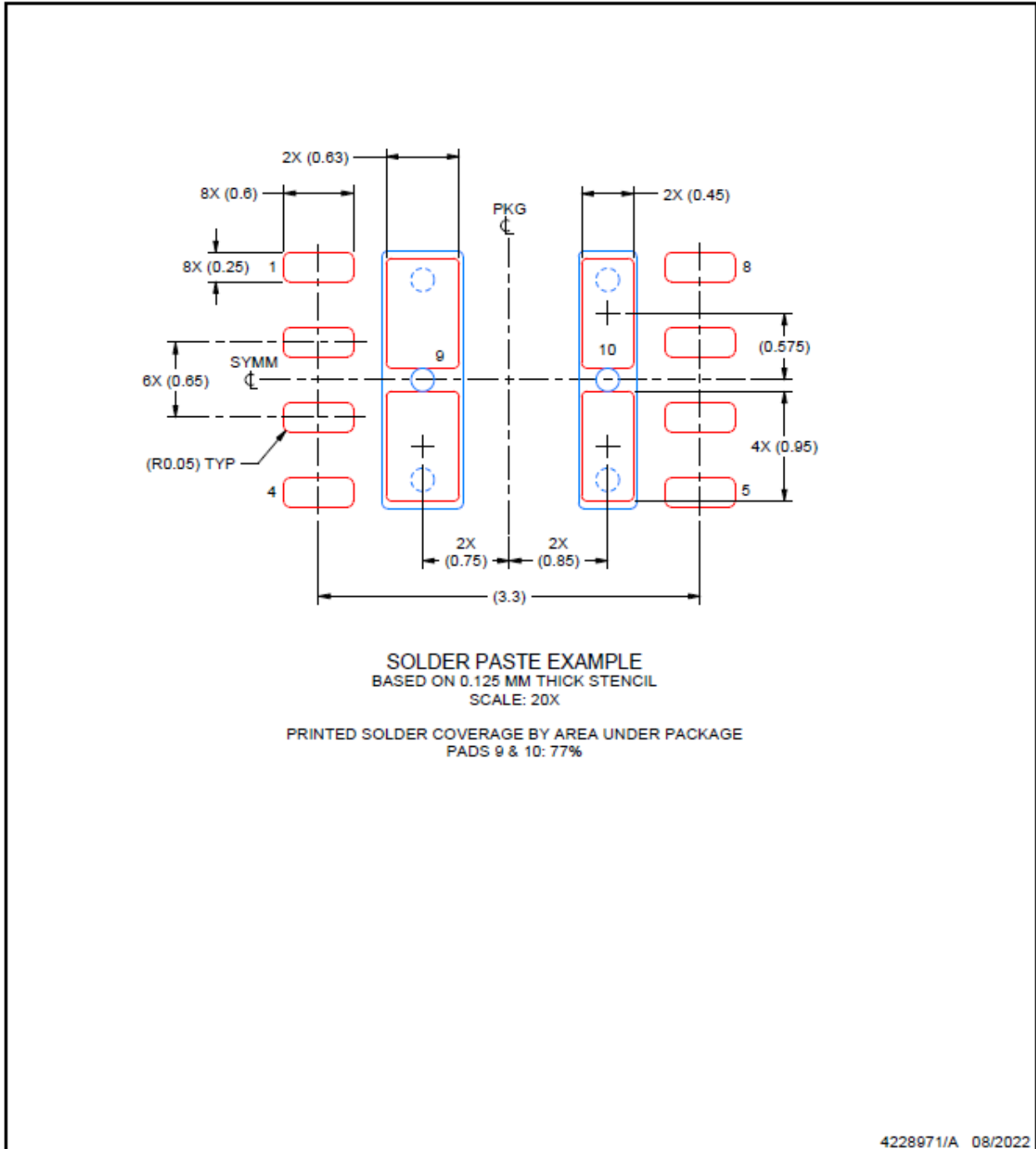

NOTES: (continued)

6. Laser cutting apertures with trapezoidal walls and rounded corners may offer better paste release. IPC-7525 may have alternate design recommendations.

ADVANCE INFORMATION

## 重要なお知らせと免責事項

テキサス・インスツルメンツは、技術データと信頼性データ (データシートを含みます)、設計リソース (リファレンス デザインを含みます)、アプリケーションや設計に関する各種アドバイス、Web ツール、安全性情報、その他のリソースを、欠陥が存在する可能性のある「現状のまま」提供しており、商品性および特定目的に対する適合性の黙示保証、第三者の知的財産権の非侵害保証を含むいかなる保証も、明示的または黙示的にかかわらず拒否します。

これらのリソースは、テキサス・インスツルメンツ製品を使用する設計の経験を積んだ開発者への提供を意図したものです。(1) お客様のアプリケーションに適した テキサス・インスツルメンツ製品の選定、(2) お客様のアプリケーションの設計、検証、試験、(3) お客様のアプリケーションに該当する各種規格や、その他のあらゆる安全性、セキュリティ、規制、または他の要件への確実な適合に関する責任を、お客様のみが単独で負うものとします。

上記の各種リソースは、予告なく変更される可能性があります。これらのリソースは、リソースで説明されている テキサス・インスツルメンツ製品を使用するアプリケーションの開発の目的でのみ、テキサス・インスツルメンツはその使用をお客様に許諾します。これらのリソースに関して、他の目的で複製することや掲載することは禁止されています。テキサス・インスツルメンツや第三者の知的財産権のライセンスが付与されている訳ではありません。お客様は、これらのリソースを自身で使用した結果発生するあらゆる申し立て、損害、費用、損失、責任について、テキサス・インスツルメンツおよびその代理人を完全に補償するものとし、テキサス・インスツルメンツは一切の責任を拒否します。

テキサス・インスツルメンツの製品は、[テキサス・インスツルメンツの販売条件](#)、または [ti.com](https://www.ti.com) やかかる テキサス・インスツルメンツ製品の関連資料などのいずれかを通じて提供する適用可能な条項の下で提供されています。テキサス・インスツルメンツがこれらのリソースを提供することは、適用されるテキサス・インスツルメンツの保証または他の保証の放棄の拡大や変更を意味するものではありません。

お客様がいかなる追加条項または代替条項を提案した場合でも、テキサス・インスツルメンツはそれらに異議を唱え、拒否します。

郵送先住所: Texas Instruments, Post Office Box 655303, Dallas, Texas 75265

Copyright © 2024, Texas Instruments Incorporated



**PACKAGING INFORMATION**

Orderable Device	Status (1)	Package Type	Package Drawing	Pins	Package Qty	Eco Plan (2)	Lead finish/ Ball material (6)	MSL Peak Temp (3)	Op Temp (°C)	Device Marking (4/5)	Samples
PAMC0106M25DENR	ACTIVE	VSON	DEN	8	5000	TBD	Call TI	Call TI	-40 to 125		Samples

(1) The marketing status values are defined as follows:

**ACTIVE:** Product device recommended for new designs.

**LIFEBUY:** TI has announced that the device will be discontinued, and a lifetime-buy period is in effect.

**NRND:** Not recommended for new designs. Device is in production to support existing customers, but TI does not recommend using this part in a new design.

**PREVIEW:** Device has been announced but is not in production. Samples may or may not be available.

**OBsolete:** TI has discontinued the production of the device.

(2) **RoHS:** TI defines "RoHS" to mean semiconductor products that are compliant with the current EU RoHS requirements for all 10 RoHS substances, including the requirement that RoHS substance do not exceed 0.1% by weight in homogeneous materials. Where designed to be soldered at high temperatures, "RoHS" products are suitable for use in specified lead-free processes. TI may reference these types of products as "Pb-Free".

**RoHS Exempt:** TI defines "RoHS Exempt" to mean products that contain lead but are compliant with EU RoHS pursuant to a specific EU RoHS exemption.

**Green:** TI defines "Green" to mean the content of Chlorine (Cl) and Bromine (Br) based flame retardants meet JS709B low halogen requirements of <=1000ppm threshold. Antimony trioxide based flame retardants must also meet the <=1000ppm threshold requirement.

(3) MSL, Peak Temp. - The Moisture Sensitivity Level rating according to the JEDEC industry standard classifications, and peak solder temperature.

(4) There may be additional marking, which relates to the logo, the lot trace code information, or the environmental category on the device.

(5) Multiple Device Markings will be inside parentheses. Only one Device Marking contained in parentheses and separated by a "~" will appear on a device. If a line is indented then it is a continuation of the previous line and the two combined represent the entire Device Marking for that device.

(6) Lead finish/Ball material - Orderable Devices may have multiple material finish options. Finish options are separated by a vertical ruled line. Lead finish/Ball material values may wrap to two lines if the finish value exceeds the maximum column width.

**Important Information and Disclaimer:** The information provided on this page represents TI's knowledge and belief as of the date that it is provided. TI bases its knowledge and belief on information provided by third parties, and makes no representation or warranty as to the accuracy of such information. Efforts are underway to better integrate information from third parties. TI has taken and continues to take reasonable steps to provide representative and accurate information but may not have conducted destructive testing or chemical analysis on incoming materials and chemicals. TI and TI suppliers consider certain information to be proprietary, and thus CAS numbers and other limited information may not be available for release.

In no event shall TI's liability arising out of such information exceed the total purchase price of the TI part(s) at issue in this document sold by TI to Customer on an annual basis.

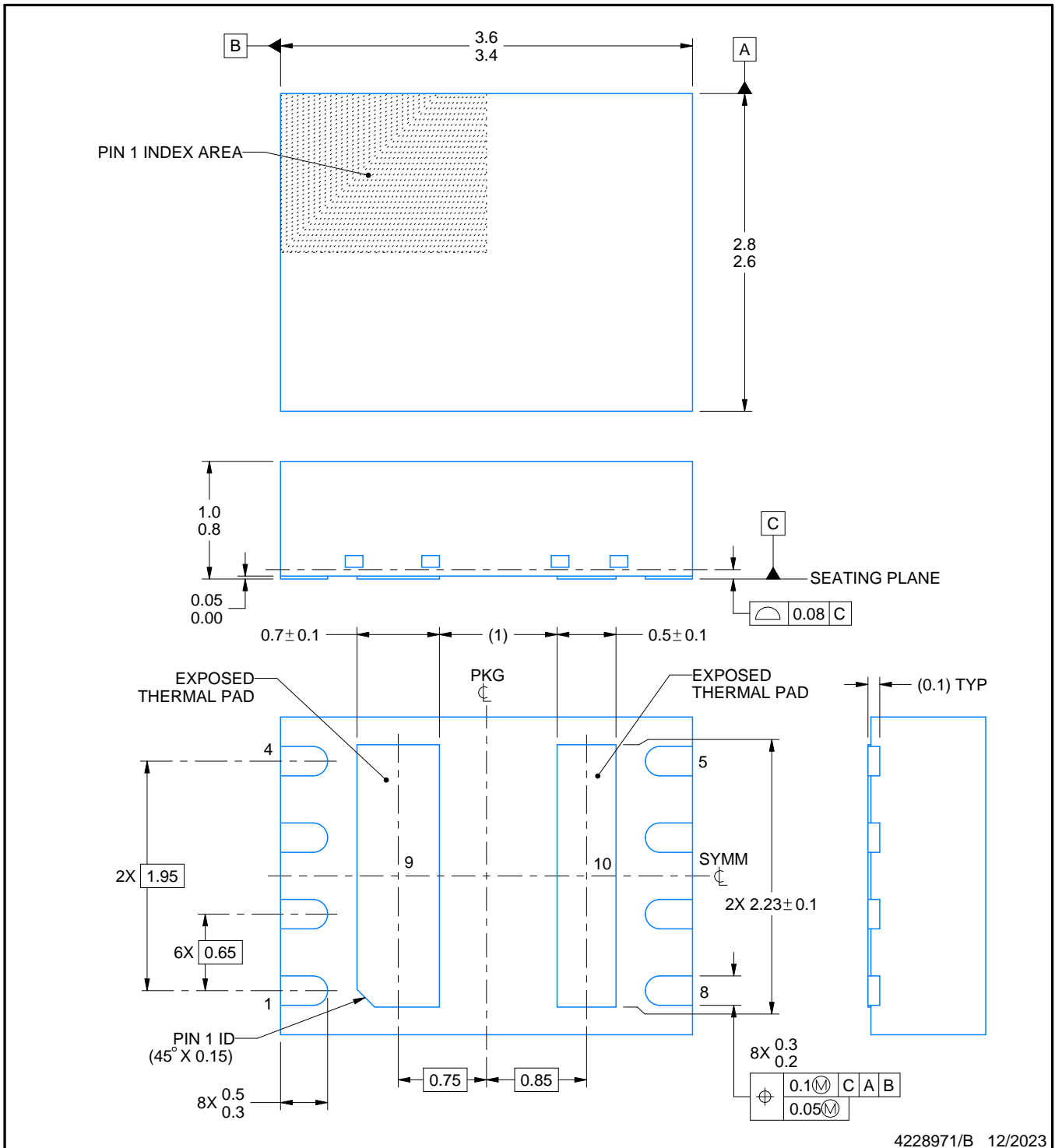

4228971/B 12/2023

NOTES:

1. All linear dimensions are in millimeters. Any dimensions in parenthesis are for reference only. Dimensioning and tolerancing per ASME Y14.5M.
2. This drawing is subject to change without notice.
3. The package thermal pad must be soldered to the printed circuit board for thermal and mechanical performance.

# EXAMPLE BOARD LAYOUT

DEN0008A

VSON - 1 mm max height

PLASTIC SMALL OUTLINE - NO LEAD

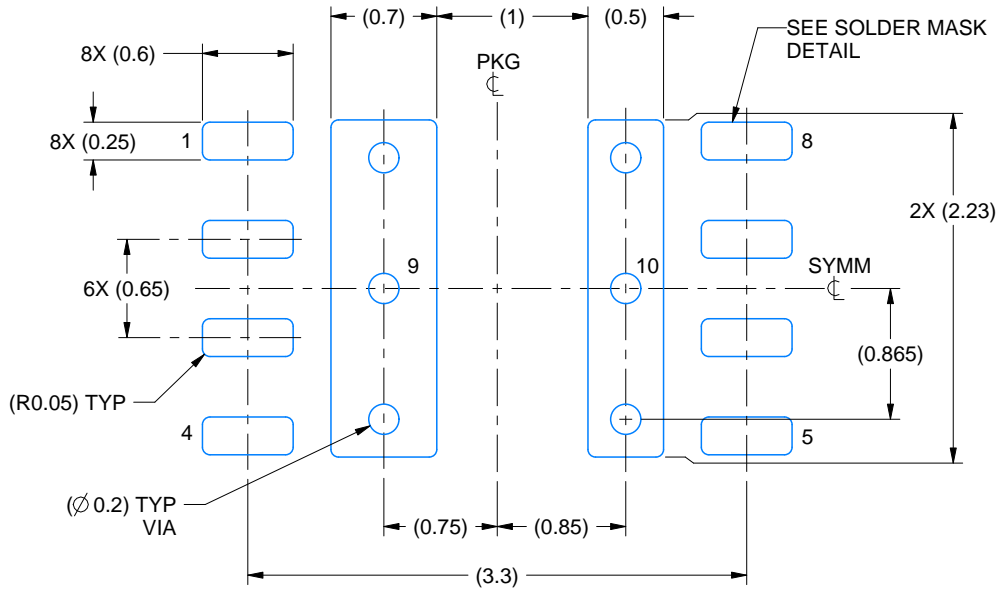

LAND PATTERN EXAMPLE  
EXPOSED METAL SHOWN  
SCALE: 20X

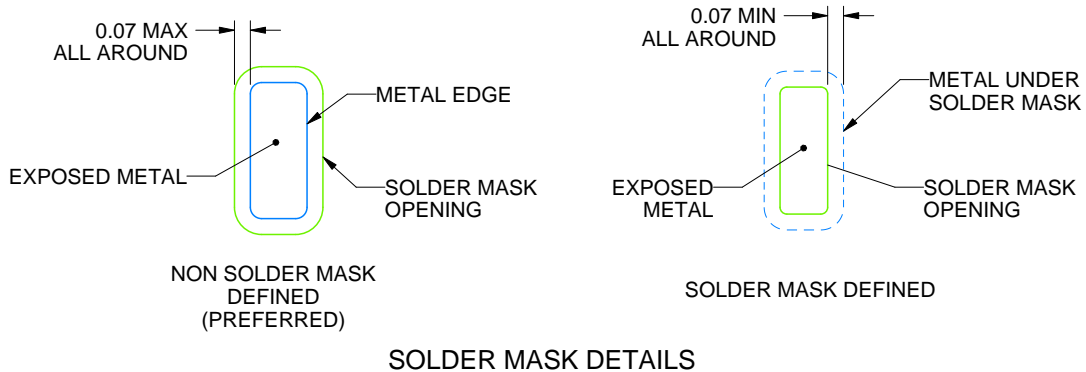

4228971/B 12/2023

NOTES: (continued)

4. This package is designed to be soldered to a thermal pad on the board. For more information, see Texas Instruments literature number SLUA271 ([www.ti.com/lit/slua271](http://www.ti.com/lit/slua271)).
5. Vias are optional depending on application, refer to device data sheet. If any vias are implemented, refer to their locations shown on this view. It is recommended that vias under paste be filled, plugged or tented.

# EXAMPLE STENCIL DESIGN

DEN0008A

VSON - 1 mm max height

PLASTIC SMALL OUTLINE - NO LEAD

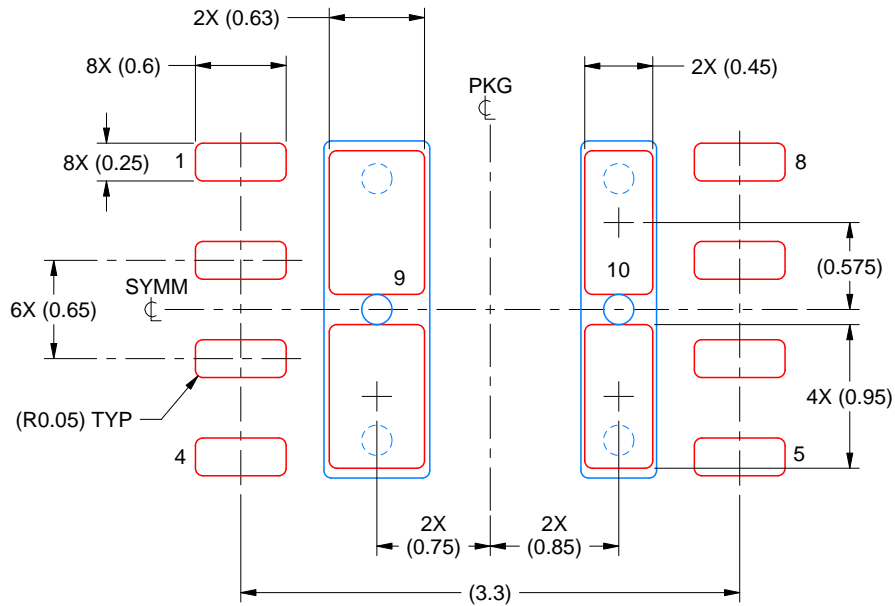

SOLDER PASTE EXAMPLE  
BASED ON 0.125 MM THICK STENCIL  
SCALE: 20X

PRINTED SOLDER COVERAGE BY AREA UNDER PACKAGE  
PADS 9 & 10: 77%

4228971/B 12/2023

NOTES: (continued)

6. Laser cutting apertures with trapezoidal walls and rounded corners may offer better paste release. IPC-7525 may have alternate design recommendations.

## 重要なお知らせと免責事項

TI は、技術データと信頼性データ (データシートを含みます)、設計リソース (リファレンス・デザインを含みます)、アプリケーションや設計に関する各種アドバイス、Web ツール、安全性情報、その他のリソースを、欠陥が存在する可能性のある「現状のまま」提供しており、商品性および特定目的に対する適合性の黙示保証、第三者の知的財産権の非侵害保証を含むいかなる保証も、明示的または黙示的にかかわらず拒否します。

これらのリソースは、TI 製品を使用する設計の経験を積んだ開発者への提供を意図したものです。(1) お客様のアプリケーションに適した TI 製品の選定、(2) お客様のアプリケーションの設計、検証、試験、(3) お客様のアプリケーションに該当する各種規格や、その他のあらゆる安全性、セキュリティ、規制、または他の要件への確実な適合に関する責任を、お客様のみが単独で負うものとし、

上記の各種リソースは、予告なく変更される可能性があります。これらのリソースは、リソースで説明されている TI 製品を使用するアプリケーションの開発の目的でのみ、TI はその使用をお客様に許諾します。これらのリソースに関して、他の目的で複製することや掲載することは禁止されています。TI や第三者の知的財産権のライセンスが付与されている訳ではありません。お客様は、これらのリソースを自身で使用した結果発生するあらゆる申し立て、損害、費用、損失、責任について、TI およびその代理人を完全に補償するものとし、TI は一切の責任を拒否します。

TI の製品は、[TI の販売条件](#)、または [ti.com](#) やかかる TI 製品の関連資料などのいずれかを通じて提供する適用可能な条項の下で提供されています。TI がこれらのリソースを提供することは、適用される TI の保証または他の保証の放棄の拡大や変更を意味するものではありません。

お客様がいかなる追加条項または代替条項を提案した場合でも、TI はそれらに異議を唱え、拒否します。

郵送先住所 : Texas Instruments, Post Office Box 655303, Dallas, Texas 75265  
Copyright © 2024, Texas Instruments Incorporated