

# AMC1204 電流シャント測定用の 20MHz、2次、絶縁型デルタ-シグマ変調器

## 1 特長

- シャント抵抗用に最適化された  $\pm 250\text{mV}$  の入力電圧範囲
- 安全関連の認定
  - DIN VDE V 0884-11: 2017-01 に準拠した基本絶縁:  $4250\text{V}_{\text{PK}}$  (AMC1204B)
  - UL 1577 に準拠した絶縁耐圧:  $3005\text{V}_{\text{RMS}}$  で 1 分間 (AMC1204B)
  - CAN/CSA No.5A - 部品承認通達および DIN EN 61010-1
  - 動作電圧:  $1200\text{V}_{\text{PEAK}}$
  - 過渡耐性:  $15\text{kV}/\mu\text{s}$
- 優れた電磁場耐性  
(「SLLA181A アプリケーション・レポート」を参照)
- 優れた AC 特性
  - SNR: 84dB 以上
  - THD: -80dB 以下
- 優れた DC 精度
  - INL:  $\pm 8\text{LSB}$  以下
  - ゲイン誤差:  $\pm 2\%$  以下
- 同期を容易にするための外部クロック入力
- 拡張産業用温度範囲全体にわたって仕様を完全に規定

## 2 アプリケーション

- 次の用途でのシャント抵抗を使用した電流センシング
  - モーター制御
  - 自然エネルギー
  - インバータ・アプリケーション
  - 無停電電源

## 3 概要

AMC1204 と AMC1204B は、最高 20MHz のクロックで動作できる 1 ビット・デジタル出力の絶縁型デルタ-シグマ ( $\Delta\Sigma$ ) 変調器です。この変調器の出力は、磁気干渉に対して優れた耐性を持つ二酸化ケイ素 ( $\text{SiO}_2$ ) の絶縁障壁によってデジタル絶縁されています。この絶縁障壁は、UL1577、VDE V 0884-11、CSA 規格または仕様に従って最高  $4000\text{V}_{\text{PEAK}}$  (AMC1204) および  $4250\text{V}_{\text{PEAK}}$  (AMC1204B) の基本ガルバニック絶縁の要件を満たすことが認定されています。

### 製品情報<sup>(1)</sup>

型番	パッケージ	本体サイズ(公称)
AMC1204	SOIC (16)	10.30mm×7.50mm
	SOIC (8)	5.85mm×7.50mm

(1) 提供されているすべてのパッケージについては、巻末の注文情報を参照してください。

### デバイスのブロック図

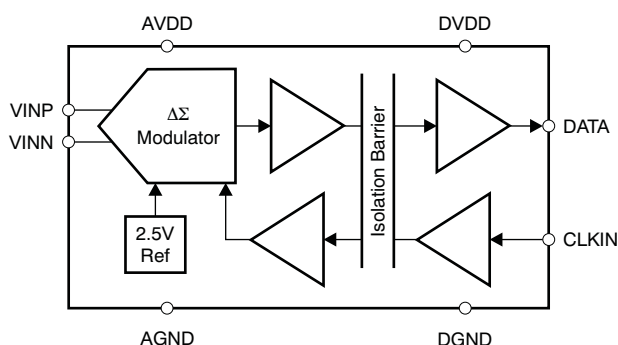

## 目次

1	特長	1	8.1	Overview	20
2	アプリケーション	1	8.2	Functional Block Diagram	20
3	概要	1	8.3	Feature Description	21
4	改訂履歴	2	8.4	Device Functional Modes	23
5	概要 (続き)	4	<b>9</b>	<b>Application and Implementation</b>	<b>24</b>
6	<b>Pin Configuration and Functions</b>	<b>5</b>	9.1	Application Information	24
7	<b>Specifications</b>	<b>6</b>	9.2	Typical Application	26
7.1	Absolute Maximum Ratings	6	<b>10</b>	<b>Power Supply Recommendations</b>	<b>29</b>
7.2	ESD Ratings	6	<b>11</b>	<b>Layout</b>	<b>30</b>
7.3	Recommended Operating Conditions	6	11.1	Layout Guidelines	30
7.4	Thermal Information	6	11.2	Layout Example	30
7.5	Power Ratings	7	<b>12</b>	<b>デバイスおよびドキュメントのサポート</b>	<b>31</b>
7.6	Insulation Specifications	7	12.1	ドキュメントのサポート	31
7.7	Safety-Related Certifications	9	12.2	ドキュメントの更新通知を受け取る方法	31
7.8	Safety Limiting Values	9	12.3	サポート・リソース	31
7.9	Electrical Characteristics	10	12.4	商標	31
7.10	Timing Requirements	11	12.5	静電気放電に関する注意事項	31
7.11	Insulation Characteristics Curves	12	12.6	Glossary	31
7.12	Typical Characteristics	13	<b>13</b>	<b>メカニカル、パッケージ、および注文情報</b>	<b>31</b>
<b>8</b>	<b>Detailed Description</b>	<b>20</b>			

## 4 改訂履歴

資料番号末尾の英字は改訂を表しています。その改訂履歴は英語版に準じています。

Revision E (September 2015) から Revision F に変更	Page
• 「デジタル絶縁認定済み」の箇条書き項目を「安全関連の認定」に変更、ISO 規格に合わせて詳細を変更	1
• 「長い絶縁バリア寿命」箇条書き項目を「特長」セクションから削除	1
• 「概要」セクションの「VDE V 0884-10」を「VDE V 0884-11」に変更	1
• 「デバイスのブロック図」のタイトルを「概略回路図」から変更	1
• Changed <i>Absolute Maximum Ratings</i> condition statement	6
• Added <i>Power Ratings</i> table	7
• Changed <i>Insulation Specifications</i> table per ISO standard	7
• Changed <i>Safety-Related Certification</i> table per ISO standard	9
• Changed <i>Safety Limiting Values</i> table per ISO standard	9
• Added <i>Insulation Characteristics Curves</i> as per ISO standard	12
• 変更「関連資料」セクション	31
• 削除「関連リンク」セクション	31

Revision D (December 2013) から Revision E に変更	Page
• 「ESD 定格」表、「機能説明」セクション、「デバイスの機能モード」セクション、「アプリケーションと実装」セクション、「電源に関する推奨事項」セクション、「レイアウト」セクション、「デバイスおよびドキュメントのサポート」セクション、「メカニカル、パッケージ、および注文情報」セクション 追加	1
• 「特長」の「デジタル絶縁認定済み」の箇条書きの最初の副項目の「IEC60747-5-5」を「VDE V 0884-10」に変更	1
• 「概要」セクションの最初の段落の「IEC60747-5-5」を「VDE V 0884-10」に変更	1

Revision C (August 2012) から Revision D に変更	Page
• 「特長」の「デジタル絶縁認定済み」の箇条書きの最初の副項目の「IEC60747-5-2」を「IEC60747-5-5」に変更 .....	1
• チップ写真を削除 .....	1
• ドキュメントに DWV (SSO-8) パッケージを追加 .....	1
• 「概要」セクションの最初の段落の「IEC60747-5-2」を「IEC60747-5-5」に変更 .....	1
• 「概要」セクションの最後の段落を変更 .....	1
• Added DWV pin out drawing .....	5
• Added DWV information to Pin Descriptions table .....	5
• Added DWV package to Thermal Information table .....	6
• Changed first paragraph of <i>Digital Output</i> section: changed 78.1% to 89.06% and 21.9% to 10.94% .....	23

Revision B (August 2011) から Revision C に変更	Page
• 「特長」の「デジタル絶縁認定済み」の絶縁電圧の箇条書き項目を変更 .....	1
• ドキュメントに AMC1204B を追加 .....	1
• 「概要」セクションを AMC1204B を含めるように変更 .....	1
• Changed package name from TSSOP to SO .....	5
• Changed footnote 1 in <i>Electrical Characteristics</i> table .....	10
• Changed Analog Inputs, $V_{CM}$ parameter minimum specification and unit in <i>Electrical Characteristics</i> table .....	10
• Changed Digital Output, $C_{OUT}$ and $C_{LOAD}$ parameters unit specifications in <i>Electrical Characteristics</i> table .....	11
• Updated <a href="#">Figure 53</a> .....	28
• Updated <a href="#">Figure 55</a> .....	29
• Updated <a href="#">Figure 56</a> .....	30

## 5 概要 (続き)

AMC1204 と AMC1204B は、絶縁障壁越しにシャント抵抗の小信号を測定するシングルチップ・ソリューションを提供します。これらのシャント抵抗は、モーター制御インバータ、自然エネルギー発電システム、その他の産業用アプリケーションで電流を検出するためによく使用されます。AMC1204 と AMC1204B の差動入力は、シャント抵抗またはその他の低レベル信号源に簡単に接続できます。内部リファレンスにより、外部部品が不要になります。適切な外部デジタル・フィルタと併用することで、78kSPS のデータ速度で 14ENOB (実効ビット数) を達成できます。

絶縁型デジタル・インターフェイスは 3V、3.3V、5V のいずれかの電源 (DVDD) で動作しますが、この変調器は 5V アナログ電源 (AVDD) を使用します。AMC1204 と AMC1204B は SOIC-16 (DW) および SOIC-8 (DWV) パッケージで供給され、 $-40^{\circ}\text{C}$  ~  $105^{\circ}\text{C}$  で動作が規定されています。

## 6 Pin Configuration and Functions

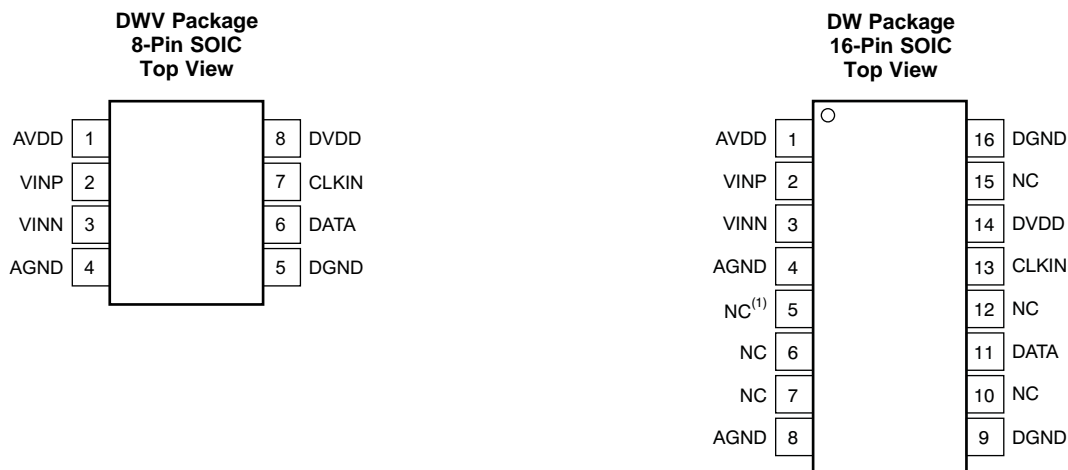

NC = no internal connection.

### Pin Functions

NAME	PIN NO.		I/O	DESCRIPTION
	NO.			
	8 PINS	16 PINS		
AVDD	1	1	Power	High-side power supply
VINP	2	2	Analog input	Noninverting analog input
VINN	3	3	Analog input	Inverting analog input
AGND	4	4, 8 <sup>(1)</sup>	Power	High-side ground
DGND	5	9, 16	Power	Controller-side ground
DATA	6	11	Digital output	Modulator data output
CLKIN	7	13	Digital input	Modulator clock input
DVDD	8	14	Power	Controller-side power supply
NC	—	5-7, 10, 12, 15	—	No internal connection; can be tied to any potential or left unconnected

(1) Both pins are connected internally via a low-impedance path; thus, only one of the pins must be tied to the ground plane.

## 7 Specifications

### 7.1 Absolute Maximum Ratings

 see <sup>(1)</sup>

	MIN	MAX	UNIT
Supply voltage, AVDD to AGND or DVDD to DGND	-0.3	6	V
Analog input voltage at VINP, VINN	AGND - 0.5	AVDD + 0.5	V
Digital input voltage at CLKIN	DGND - 0.3	DVDD + 0.3	V
Input current to any pin except supply pins	-10	10	mA
Maximum virtual junction temperature, T <sub>J</sub>		150	°C
Operating ambient temperature, T <sub>OA</sub>	-40	125	°C
Storage temperature, T <sub>stg</sub>	-65	150	°C

- (1) Stresses beyond those listed under absolute maximum ratings may cause permanent damage to the device. These are stress ratings only, and functional operation of the device at these or any other conditions beyond those indicated under the [Electrical Characteristics](#) is not implied. Exposure to absolute maximum rated conditions for extended periods may affect device reliability.

### 7.2 ESD Ratings

			VALUE	UNIT
V <sub>(ESD)</sub>	Electrostatic discharge	Human-body model (HBM), per JEDEC standard 22, test method A114-C.01 <sup>(1)</sup>	±3000	V
		Charged-device model (CDM), per JEDEC standard 22, test method C101 <sup>(2)</sup>	±1500	
		Machine model (MM), per JEDEC standard 22, test method A115A	±200	

- (1) JEDEC document JEP155 states that 500-V HBM allows safe manufacturing with a standard ESD control process.  
 (2) JEDEC document JEP157 states that 250-V CDM allows safe manufacturing with a standard ESD control process.

### 7.3 Recommended Operating Conditions

over operating free-air temperature range (unless otherwise noted)

		MIN	NOM	MAX	UNIT
T <sub>A</sub>	Operating ambient temperature	-40		105	°C
AVDD	High-side (analog) supply voltage	4.5	5	5.5	V
DVDD	Controller-side (digital) supply voltage	2.7	3.3	5.5	V

### 7.4 Thermal Information

THERMAL METRIC <sup>(1)</sup>		AMC1204, AMC1204B		UNIT
		DW (SOIC)	DWV (SOIC)	
		16 PINS	8 PINS	
R <sub>θJA</sub>	Junction-to-ambient thermal resistance	78.5	106.5	°C/W
R <sub>θJC(top)</sub>	Junction-to-case (top) thermal resistance	41.3	53.6	°C/W
R <sub>θJB</sub>	Junction-to-board thermal resistance	50.2	60.3	°C/W
ψ <sub>JT</sub>	Junction-to-top characterization parameter	11.5	18.5	°C/W
ψ <sub>JB</sub>	Junction-to-board characterization parameter	41.2	58.9	°C/W
R <sub>θJC(bot)</sub>	Junction-to-case (bottom) thermal resistance	n/a	n/a	°C/W

- (1) For more information about traditional and new thermal metrics, see the [Semiconductor and IC package thermal metrics application report](#).

## 7.5 Power Ratings

PARAMETER		TEST CONDITIONS	MIN	TYP	MAX	UNIT
P <sub>D</sub>	Maximum power dissipation (both sides)	AVDD = DVDD = 5.5 V			115.5	mW
		AVDD = 5.5 V, DVDD = 3.6 V			102.4	
P <sub>D1</sub>	Maximum power dissipation (high-side supply)	AVDD = 5.5 V			88.0	mW
P <sub>D2</sub>	Maximum power dissipation (low-side supply)	DVDD = 5.5 V			27.5	mW
		DVDD = 3.6 V			14.4	

## 7.6 Insulation Specifications

over operating ambient temperature range (unless otherwise noted)

PARAMETER		TEST CONDITIONS	VALUE	UNIT
<b>GENERAL</b>				
CLR	External clearance <sup>(1)</sup>	Shortest pin-to-pin distance through air, DW package	≥ 8	mm
		Shortest pin-to-pin distance through air, DWV package	≥ 8.5	
CPG	External creepage <sup>(1)</sup>	Shortest pin-to-pin distance across the package surface, DW package	≥ 8	mm
		Shortest pin-to-pin distance across the package surface, DWV package	≥ 8.5	
DTI	Distance through insulation	Minimum internal gap (internal clearance) of the insulation	≥ 0.014	mm
CTI	Comparative tracking index	DIN EN 60112 (VDE 0303-11); IEC 60112, DW package	≥ 400	V
		DIN EN 60112 (VDE 0303-11); IEC 60112, DWV package	≥ 175	
	Material group	According to IEC 60664-1, DW package	II	
		According to IEC 60664-1, DWV package	III	
	Overvoltage category per IEC 60664-1	Rated mains voltage ≤ 300 V <sub>RMS</sub>	I-IV	
		Rated mains voltage ≤ 600 V <sub>RMS</sub>	I-III	
<b>DIN VDE V 0884-11: 2017-01<sup>(2)</sup></b>				
V <sub>IORM</sub>	Maximum repetitive peak isolation voltage	At ac voltage (bipolar)	1200	V <sub>PK</sub>
V <sub>IOWM</sub>	Maximum-rated isolation working voltage	At ac voltage (sine wave)	849	V <sub>RMS</sub>
		At dc voltage	1200	V <sub>DC</sub>
V <sub>IOTM</sub>	Maximum transient isolation voltage	V <sub>TEST</sub> = V <sub>IOTM</sub> , t = 60 s (qualification test), AMC1204B	4250	V <sub>PK</sub>
		V <sub>TEST</sub> = 1.2 × V <sub>IOTM</sub> , t = 1 s (100% production test), AMC1204B	5100	
		V <sub>TEST</sub> = V <sub>IOTM</sub> , t = 60 s (qualification test), AMC1204	4000	
		V <sub>TEST</sub> = 1.2 × V <sub>IOTM</sub> , t = 1 s (100% production test), AMC1204	4800	
V <sub>IOSM</sub>	Maximum surge isolation voltage <sup>(3)</sup>	Test method per IEC 60065, 1.2/50-μs waveform, V <sub>TEST</sub> = 1.3 × V <sub>IOSM</sub> = 6000 V <sub>PK</sub> (qualification)	4615	V <sub>PK</sub>

- (1) Apply creepage and clearance requirements according to the specific equipment isolation standards of an application. Care must be taken to maintain the creepage and clearance distance of a board design to ensure that the mounting pads of the isolator on the printed circuit board (PCB) do not reduce this distance. Creepage and clearance on a PCB become equal in certain cases. Techniques such as inserting grooves and ribs on the PCB are used to help increase these specifications.
- (2) This coupler is suitable for *safe electrical insulation* only within the safety ratings. Compliance with the safety ratings shall be ensured by means of suitable protective circuits.
- (3) Testing is carried out in air or oil to determine the intrinsic surge immunity of the isolation barrier.

**Insulation Specifications (continued)**

over operating ambient temperature range (unless otherwise noted)

PARAMETER		TEST CONDITIONS	VALUE	UNIT
q <sub>pd</sub>	Apparent charge <sup>(4)</sup>	Method a, after input/output safety test subgroup 2 / 3, V <sub>ini</sub> = V <sub>IOTM</sub> , t <sub>ini</sub> = 60 s, V <sub>pd(m)</sub> = 1.2 × V <sub>IORM</sub> = 1440 V <sub>PK</sub> , t <sub>m</sub> = 10 s	≤ 5	pC
		Method a, after environmental tests subgroup 1, V <sub>ini</sub> = V <sub>IOTM</sub> , t <sub>ini</sub> = 60 s, V <sub>pd(m)</sub> = 1.3 × V <sub>IORM</sub> = 1560 V <sub>PK</sub> , t <sub>m</sub> = 10 s	≤ 5	
		Method b1, at routine test (100% production) and preconditioning (type test), V <sub>ini</sub> = V <sub>IOTM</sub> , t <sub>ini</sub> = 1 s, V <sub>pd(m)</sub> = 1.5 × V <sub>IORM</sub> = 1800 V <sub>PK</sub> , t <sub>m</sub> = 1 s	≤ 5	
C <sub>IO</sub>	Barrier capacitance, input to output <sup>(5)</sup>	V <sub>IO</sub> = 0.5 V <sub>PP</sub> at 1 MHz	1.2	pF
R <sub>IO</sub>	Insulation resistance, input to output <sup>(5)</sup>	V <sub>IO</sub> = 500 V at T <sub>A</sub> < 85°C	> 10 <sup>12</sup>	Ω
		V <sub>IO</sub> = 500 V at 85°C < T <sub>A</sub> < 105°C	> 10 <sup>11</sup>	
		V <sub>IO</sub> = 500 V at T <sub>S</sub> = 150°C	> 10 <sup>9</sup>	
	Pollution degree		2	
	Climatic category		40/125/21	
<b>UL1577</b>				
V <sub>ISO</sub>	Withstand isolation voltage	V <sub>TEST</sub> = V <sub>ISO</sub> = 3005 V <sub>RMS</sub> or 4250 V <sub>DC</sub> , t = 60 s (qualification), V <sub>TEST</sub> = 1.2 × V <sub>ISO</sub> = 3606 V <sub>RMS</sub> , t = 1 s (100% production test), AMC1204B	3005	V <sub>RMS</sub>
		V <sub>TEST</sub> = V <sub>ISO</sub> = 2500 V <sub>RMS</sub> or 4000 V <sub>DC</sub> , t = 60 s (qualification), V <sub>TEST</sub> = 1.2 × V <sub>ISO</sub> = 2800 V <sub>RMS</sub> , t = 1 s (100% production test), AMC1204	2500	

(4) Apparent charge is electrical discharge caused by a partial discharge (pd).

(5) All pins on each side of the barrier are tied together, creating a two-pin device.



## 7.7 Safety-Related Certifications

VDE	UL	CSA
Certified according to DIN VDE V 0884-11: 2017-01 and DIN EN 61010-1 (VDE 0411-1): 2011-07	Recognized under 1577 component recognition program	Recognized under CSA component acceptance NO 5 program, IEC 60950-1, and IEC 61010-1
Basic insulation	Single protection	Basic insulation
Certificate number: 40047657	File number: E181974	Certificate number: 2350550

## 7.8 Safety Limiting Values

Safety limiting intends to minimize potential damage to the isolation barrier upon failure of input or output circuitry.

PARAMETER		TEST CONDITIONS	MIN	TYP	MAX	UNIT
I <sub>S</sub>	Safety input, output, or supply current	DW-package, R <sub>θJA</sub> = 78.5°C/W, T <sub>J</sub> = 150°C, T <sub>A</sub> = 25°C, AVDD = DVDD = 5.5 V, see <a href="#">Figure 2</a>			289	mA
		DWV-package, R <sub>θJA</sub> = 106.5°C/W, T <sub>J</sub> = 150°C, T <sub>A</sub> = 25°C, AVDD = DVDD = 5.5 V, see <a href="#">Figure 2</a>			213	
P <sub>S</sub>	Safety input, output, or total power <sup>(1)</sup>	DW-package, R <sub>θJA</sub> = 78.5°C/W, T <sub>J</sub> = 150°C, T <sub>A</sub> = 25°C, see <a href="#">Figure 3</a>			1592	mW
		DWV-package, R <sub>θJA</sub> = 106.5°C/W, T <sub>J</sub> = 150°C, T <sub>A</sub> = 25°C, see <a href="#">Figure 3</a>			1173	mW
T <sub>S</sub>	Maximum safety temperature				150	°C

- (1) The maximum safety temperature, T<sub>S</sub>, has the same value as the maximum junction temperature, T<sub>J</sub>, specified for the device. The I<sub>S</sub> and P<sub>S</sub> parameters represent the safety current and safety power, respectively. Do not exceed the maximum limits of I<sub>S</sub> and P<sub>S</sub>. These limits vary with the ambient temperature, T<sub>A</sub>.

The junction-to-air thermal resistance, R<sub>θJA</sub>, in the [Thermal Information](#) table is that of a device installed on a high-K test board for leaded surface-mount packages. Use these equations to calculate the value for each parameter:

$T_J = T_A + R_{\theta JA} \times P$ , where P is the power dissipated in the device.

$T_{J(max)} = T_S = T_A + R_{\theta JA} \times P_S$ , where T<sub>J(max)</sub> is the maximum junction temperature.

$P_S = I_S \times AVDD_{max} + I_S \times DVDD_{max}$ , where AVDD<sub>max</sub> is the maximum high-side supply voltage and DVDD<sub>max</sub> is the maximum controller-side supply voltage.

## 7.9 Electrical Characteristics

All minimum/maximum specifications at  $T_A = -40^\circ\text{C}$  to  $105^\circ\text{C}$ ,  $AVDD = 4.5\text{ V}$  to  $5.5\text{ V}$ ,  $DVDD = 2.7\text{ V}$  to  $5.5\text{ V}$ ,  $VINP = -250\text{ mV}$  to  $250\text{ mV}$ ,  $VINN = 0\text{ V}$ , and sinc<sup>3</sup> filter with OSR = 256, unless otherwise noted.

Typical values are at  $T_A = 25^\circ\text{C}$ ,  $AVDD = 5\text{ V}$ , and  $DVDD = 3.3\text{ V}$ .

PARAMETER		TEST CONDITIONS	MIN	TYP	MAX	UNIT
<b>RESOLUTION</b>						
	Resolution		16			Bits
<b>DC ACCURACY</b>						
INL	Integral linearity error <sup>(1)</sup>	$T_A = -40^\circ\text{C}$ to $85^\circ\text{C}$	-8	±2	8	LSB
		$T_A = -40^\circ\text{C}$ to $105^\circ\text{C}$	-16	±5	16	LSB
DNL	Differential nonlinearity		-1		1	LSB
$V_{OS}$	Offset error <sup>(2)</sup>		-1	±0.1	1	mV
$TCV_{OS}$	Offset error thermal drift		-3.5	±1	3.5	µV/°C
$G_{ERR}$	Gain error <sup>(2)</sup>		-2%	±0.5%	2%	
$TCG_{ERR}$	Gain error thermal drift			±30		ppm/°C
PSRR	Power-supply rejection ratio			79		dB
<b>ANALOG INPUTS</b>						
FSR	Full-scale differential voltage input range	$VINP - VINN$		±320		mV
		Specified FSR	-250		250	mV
$V_{CM}$	Operating common-mode signal <sup>(3)</sup>		-160		$AVDD$	mV
$C_I$	Input capacitance to AGND	$VINP$ or $VINN$		7		pF
$C_{ID}$	Differential input capacitance			3.5		pF
$R_{ID}$	Differential input resistance			12.5		kΩ
$I_{IL}$	Input leakage current	$VINP - VINN = \pm 250\text{ mV}$	-10		10	µA
		$VINP - VINN = \pm 320\text{ mV}$	-50		50	µA
CMTI	Common-mode transient immunity		15			kV/µs
CMRR	Common-mode rejection ratio	$V_{IN}$ from 0 V to 5 V at 0 Hz		108		dB
		$V_{IN}$ from 0 V to 5 V at 100 kHz		114		dB
<b>EXTERNAL CLOCK</b>						
$t_{CLKIN}$	Clock period		45.5	50	200	ns
$f_{CLKIN}$	Input clock frequency		5	20	22	MHz
Duty <sub>CLKIN</sub>	Duty cycle	$5\text{ MHz} \leq f_{CLKIN} < 20\text{ MHz}$	40%	50%	60%	
		$20\text{ MHz} \leq f_{CLKIN} \leq 22\text{ MHz}$	45%	50%	55%	
<b>AC ACCURACY</b>						
SINAD	Signal-to-noise + distortion	$f_{IN} = 1\text{ kHz}$ , $T_A = -40^\circ\text{C}$ to $85^\circ\text{C}$	78	87		dB
		$f_{IN} = 1\text{ kHz}$ , $T_A = -40^\circ\text{C}$ to $105^\circ\text{C}$	70	87		dB
SNR	Signal-to-noise ratio	$f_{IN} = 1\text{ kHz}$ , $T_A = -40^\circ\text{C}$ to $85^\circ\text{C}$	84	88		dB
		$f_{IN} = 1\text{ kHz}$ , $T_A = -40^\circ\text{C}$ to $105^\circ\text{C}$	83	88		dB
THD	Total harmonic distortion	$f_{IN} = 1\text{ kHz}$ , $T_A = -40^\circ\text{C}$ to $85^\circ\text{C}$		-96	-80	dB
		$f_{IN} = 1\text{ kHz}$ , $T_A = -40^\circ\text{C}$ to $105^\circ\text{C}$		-96	-70	dB
SFDR	Spurious-free dynamic range	$f_{IN} = 1\text{ kHz}$ , $T_A = -40^\circ\text{C}$ to $85^\circ\text{C}$	82	96		dB
		$f_{IN} = 1\text{ kHz}$ , $T_A = -40^\circ\text{C}$ to $105^\circ\text{C}$	72	96		dB
<b>DIGITAL INPUTS<sup>(3)</sup></b>						
$I_{IN}$	Input current	$V_{IN} = DVDD$ to DGND	-10		10	µA
$C_{IN}$	Input capacitance			5		pF
<b>CMOS Logic Family (CMOS With Schmitt-Trigger)</b>						
$V_{IH}$	High-level input voltage	$DVDD = 4.5\text{ V}$ to $5.5\text{ V}$	0.7DVDD		$DVDD + 0.3$	V
$V_{IL}$	Low-level input voltage	$DVDD = 4.5\text{ V}$ to $5.5\text{ V}$	-0.3		0.3DVDD	V
<b>LVC MOS Logic Family</b>						
$V_{IH}$	High-level input voltage	$DVDD = 2.7\text{ V}$ to $3.6\text{ V}$	2		$DVDD + 0.3$	V

(1) Integral nonlinearity is defined as the maximum deviation from a straight line passing through the end-points of the ideal ADC transfer function expressed as number of LSBs or as a percent of the specified 500-mV input range.

(2) Maximum values, including temperature drift, are ensured over the full specified temperature range.

(3) Ensured by design.

## Electrical Characteristics (continued)

All minimum/maximum specifications at  $T_A = -40^\circ\text{C}$  to  $105^\circ\text{C}$ ,  $AVDD = 4.5\text{ V}$  to  $5.5\text{ V}$ ,  $DVDD = 2.7\text{ V}$  to  $5.5\text{ V}$ ,  $V_{INP} = -250\text{ mV}$  to  $250\text{ mV}$ ,  $V_{INN} = 0\text{ V}$ , and  $\text{sinc}^3$  filter with  $\text{OSR} = 256$ , unless otherwise noted.

Typical values are at  $T_A = 25^\circ\text{C}$ ,  $AVDD = 5\text{ V}$ , and  $DVDD = 3.3\text{ V}$ .

PARAMETER		TEST CONDITIONS	MIN	TYP	MAX	UNIT
$V_{IL}$	Low-level input voltage	$DVDD = 2.7\text{ V}$ to $3.6\text{ V}$	-0.3		0.8	V
<b>DIGITAL OUTPUTS<sup>(3)</sup></b>						
$C_{OUT}$	Output capacitance			5		pF
$C_{LOAD}$	Load capacitance				30	pF
<b>CMOS Logic Family</b>						
$V_{OH}$	High-level output voltage	$DVDD = 4.5\text{ V}$ , $I_{OH} = -100\ \mu\text{A}$	4.4			V
$V_{OL}$	Low-level output voltage	$DVDD = 4.5\text{ V}$ , $I_{OL} = 100\ \mu\text{A}$			0.5	V
<b>LVC MOS Logic Family</b>						
$V_{OH}$	High-level output voltage	$I_{OH} = 20\ \mu\text{A}$	$DVDD - 0.1$			V
		$I_{OH} = -4\text{ mA}$ , $2.7\text{ V} \leq DVDD \leq 3.6\text{ V}$	$DVDD - 0.4$			V
		$I_{OH} = -4\text{ mA}$ , $4.5\text{ V} \leq DVDD \leq 5.5\text{ V}$	$DVDD - 0.8$			V
$V_{OL}$	Low-level output voltage	$I_{OL} = 20\ \mu\text{A}$			0.1	V
		$I_{OL} = 4\text{ mA}$			0.4	V
<b>POWER SUPPLY</b>						
$AVDD$	High-side supply voltage		4.5	5	5.5	V
$DVDD$	Controller-side supply voltage		2.7	3.3	5.5	V
$I_{AVDD}$	High-side supply current	$4.5\text{ V} \leq AVDD \leq 5.5\text{ V}$		11	16	mA
$I_{DVDD}$	Controller-side supply current	$2.7\text{ V} \leq DVDD \leq 3.6\text{ V}$		2	4	mA
		$4.5\text{ V} \leq DVDD \leq 5.5\text{ V}$		2.8	5	mA
$P_D$	Power dissipation	$AVDD = 5.5\text{ V}$ , $DVDD = 3.6\text{ V}$		61.6	102.4	mW

## 7.10 Timing Requirements

Over recommended ranges of supply voltage and operating free-air temperature, unless otherwise noted. (See Figure 1)

		MIN	NOM	MAX	UNIT
$t_{CLK}$	CLKIN clock period	45.5	50	200	ns
$t_{HIGH}$	CLKIN clock high time	20	25	120	ns
$t_{LOW}$	CLKIN clock low time	20	25	120	ns
$t_D$	Delayed falling edge of CLKIN to DATA valid	2		15	ns

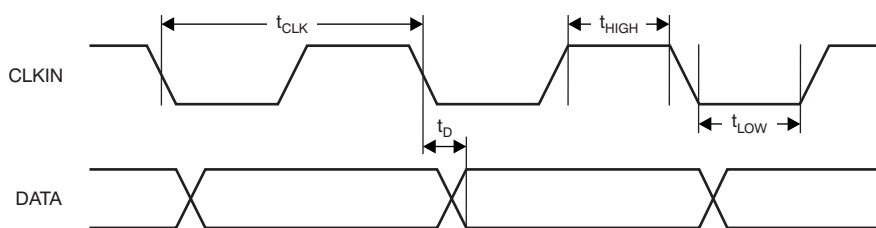

**Figure 1. Modulator Output Timing**

### 7.11 Insulation Characteristics Curves

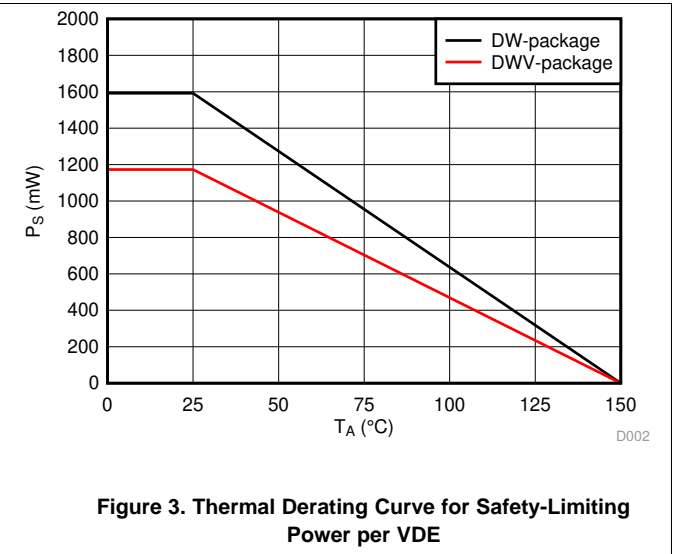
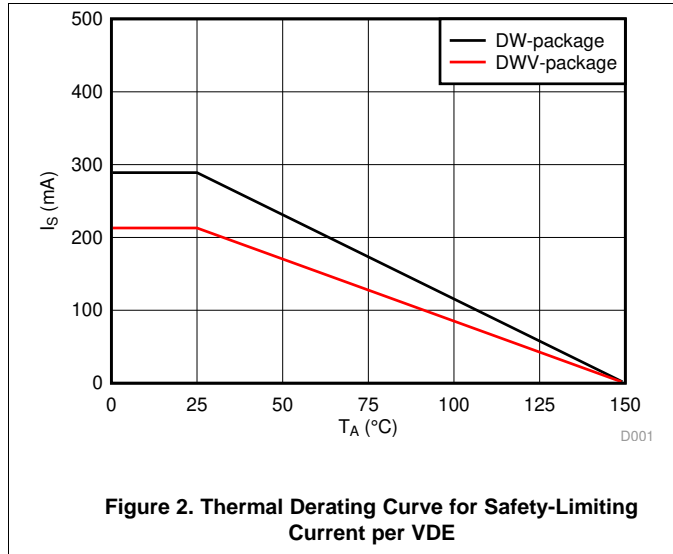

## 7.12 Typical Characteristics

at AVDD = 5 V, DVDD = 3.3 V, VINP = -250 mV to 250 mV, VINN = 0 V, and sinc<sup>3</sup> filter with OSR = 256 (unless otherwise noted)

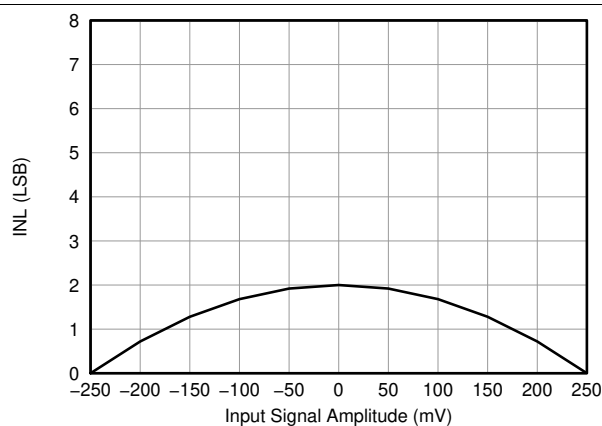

Figure 4. Integral Nonlinearity vs Input Signal Amplitude

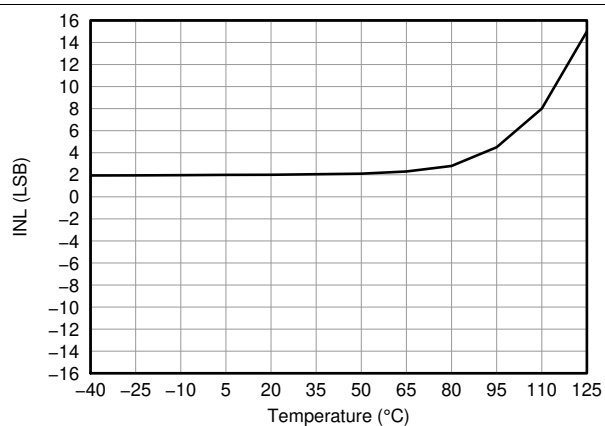

Figure 5. Integral Nonlinearity vs Temperature

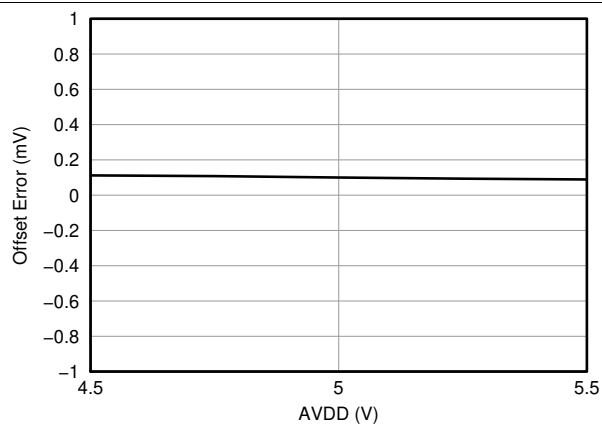

Figure 6. Offset Error vs Analog Supply Voltage

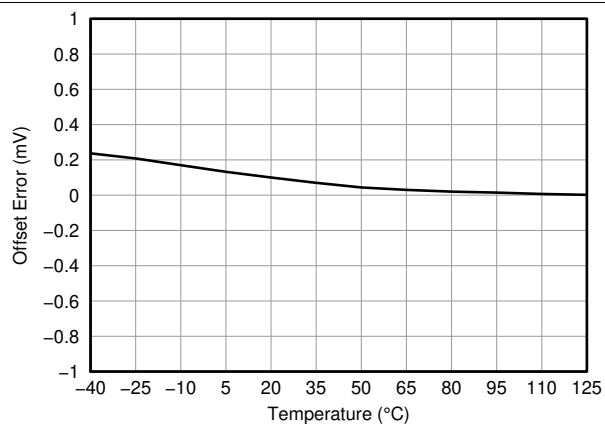

Figure 7. Offset Error vs Temperature

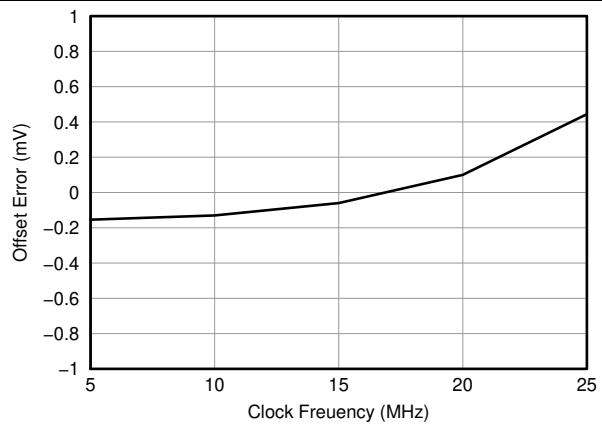

Figure 8. Offset Error vs Clock Frequency

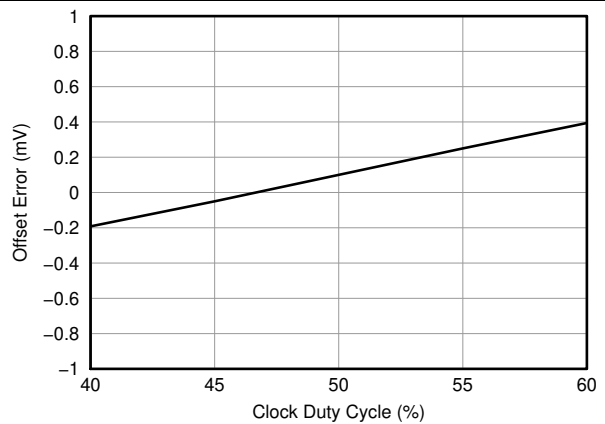
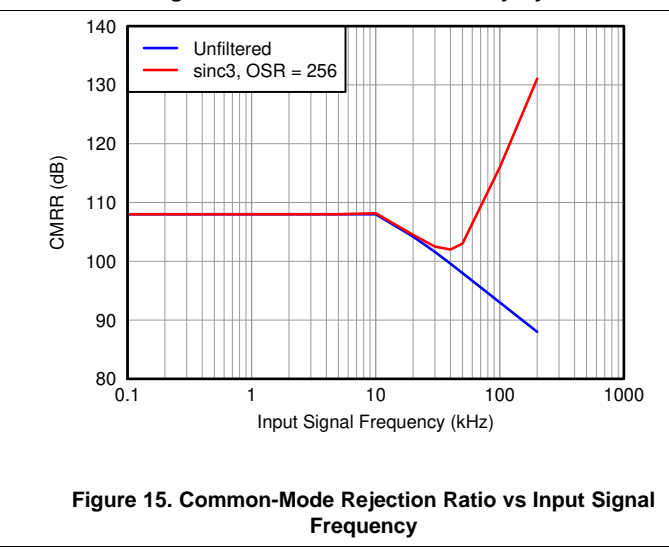
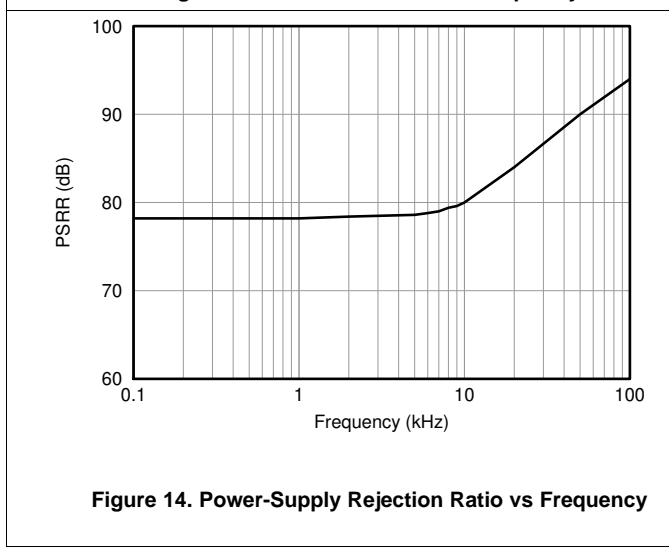
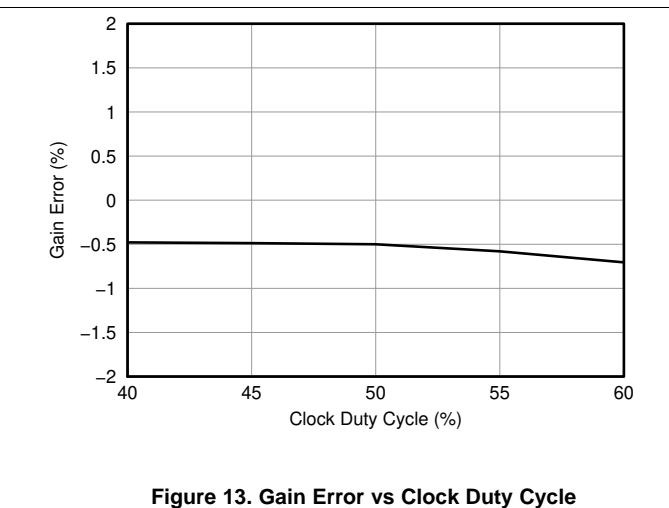
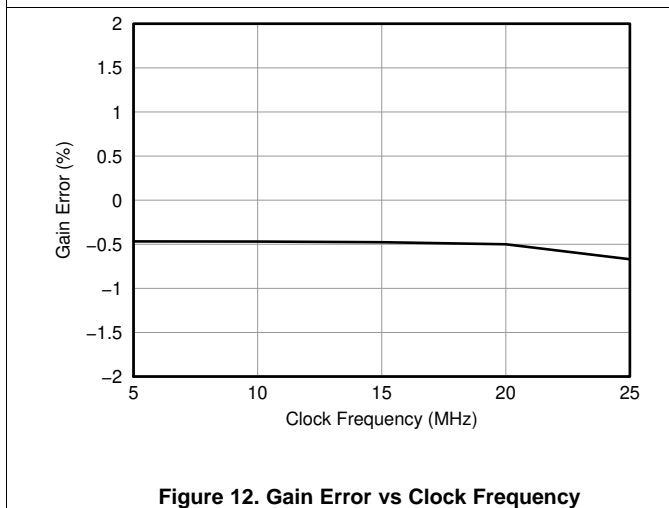
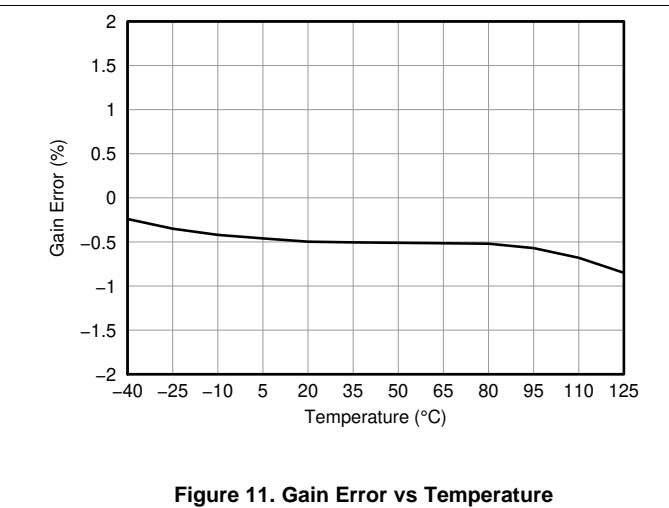
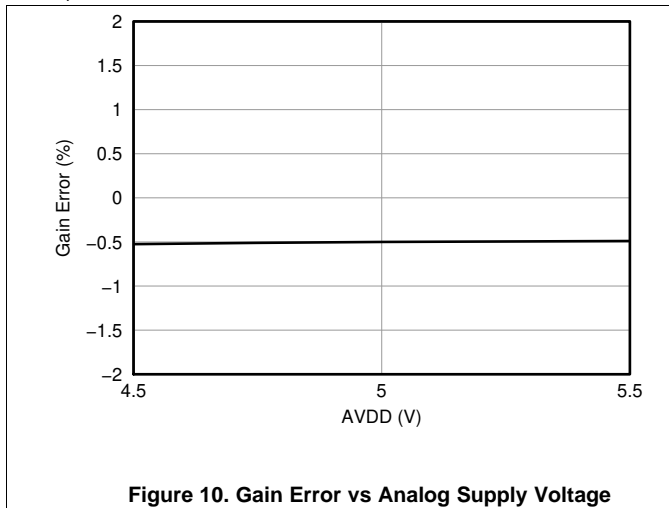

Figure 9. Offset Error vs Clock Duty Cycle

### Typical Characteristics (continued)

at AVDD = 5 V, DVDD = 3.3 V, VINP = -250 mV to 250 mV, VINN = 0 V, and sinc<sup>3</sup> filter with OSR = 256 (unless otherwise noted)



Typical Characteristics (continued)

at AVDD = 5 V, DVDD = 3.3 V, VINP = -250 mV to 250 mV, VINN = 0 V, and sinc<sup>3</sup> filter with OSR = 256 (unless otherwise noted)

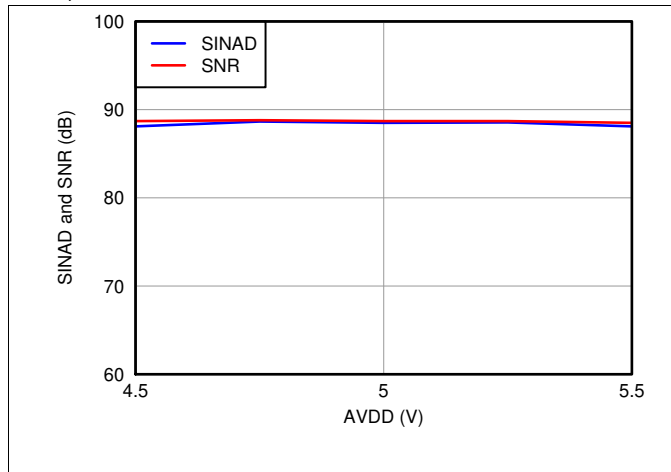

Figure 16. SINAD and SNR vs Analog Supply Voltage

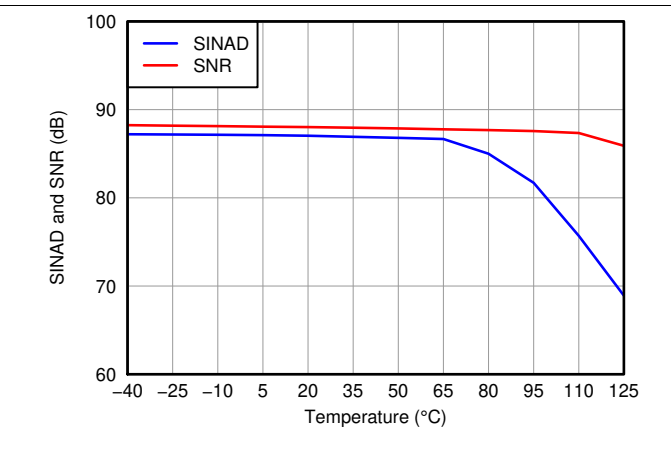

Figure 17. SINAD and SNR vs Temperature

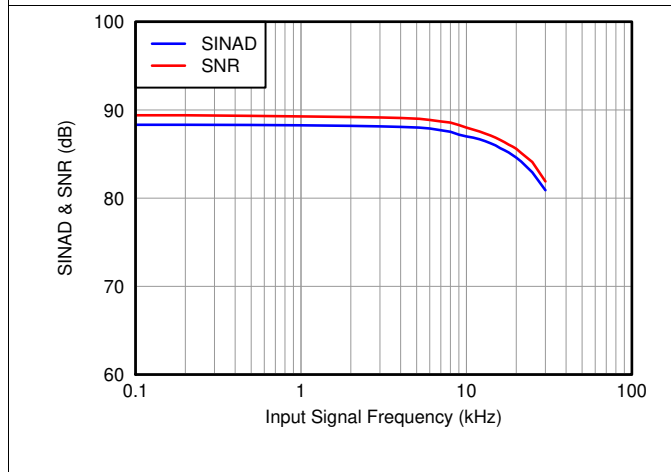

Figure 18. SINAD and SNR vs Input Signal Frequency

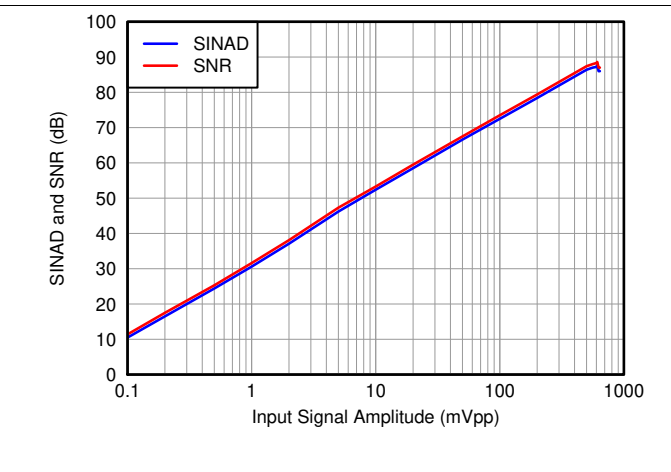

Figure 19. SINAD and SNR vs Input Signal Amplitude

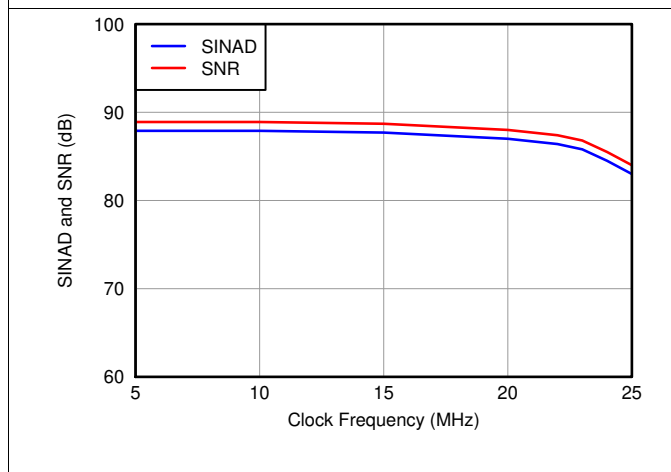

Figure 20. SINAD and SNR vs Clock Frequency

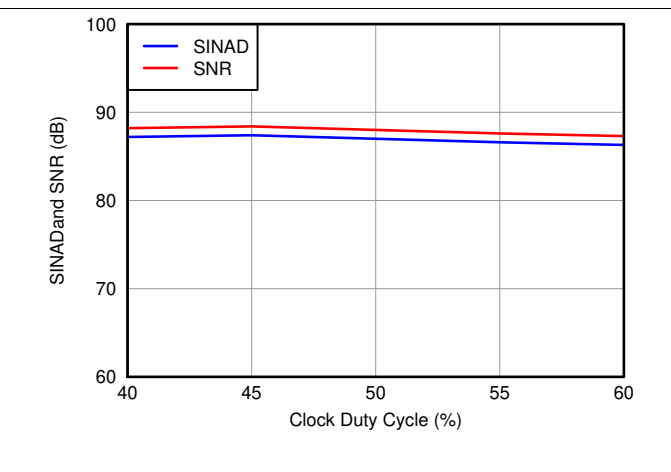

Figure 21. SINAD and SNR vs Clock Duty Cycle

### Typical Characteristics (continued)

at AVDD = 5 V, DVDD = 3.3 V, VINP = -250 mV to 250 mV, VINN = 0 V, and sinc<sup>3</sup> filter with OSR = 256 (unless otherwise noted)

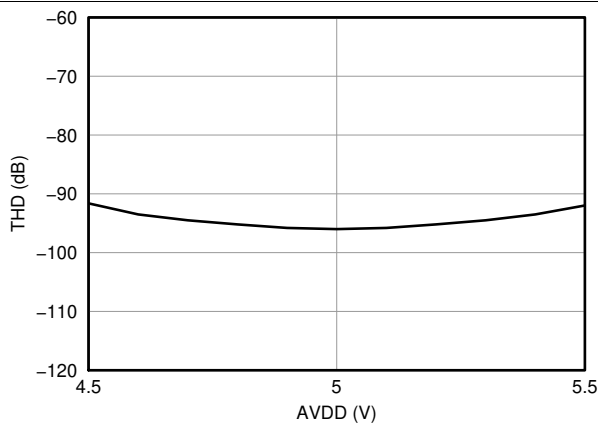

Figure 22. Total Harmonic Distortion vs Analog Supply Voltage

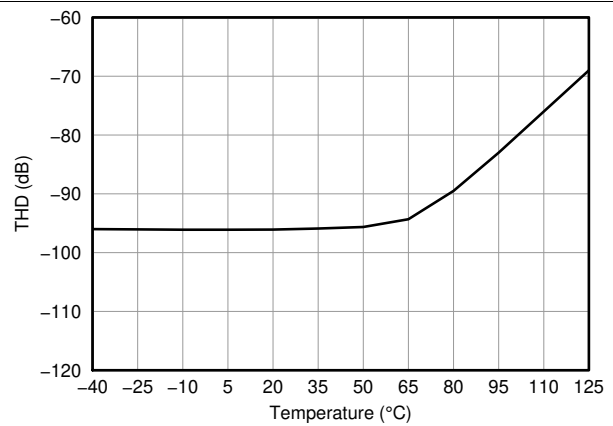

Figure 23. Total Harmonic Distortion vs Temperature

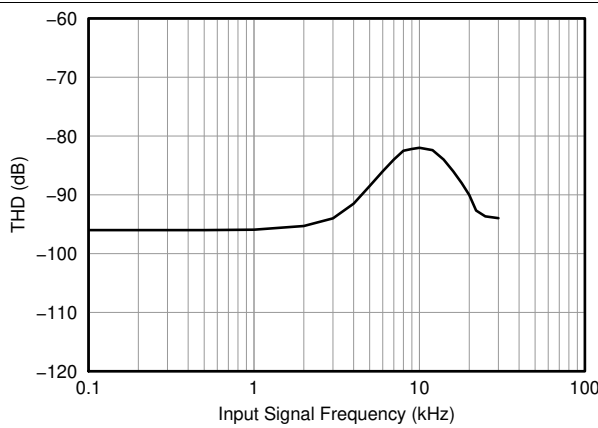

Figure 24. Total Harmonic Distortion vs Input Signal Frequency

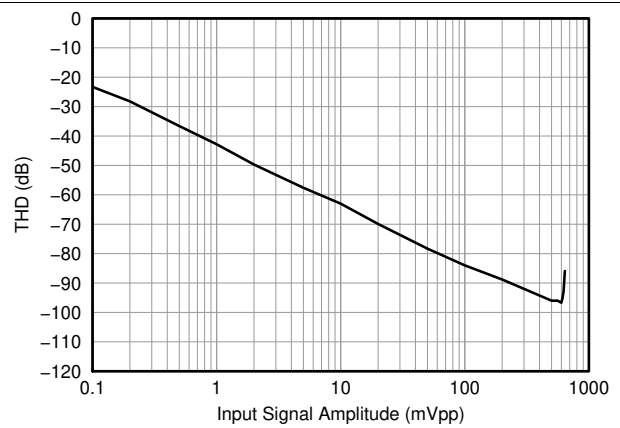

Figure 25. Total Harmonic Distortion vs Input Signal Amplitude

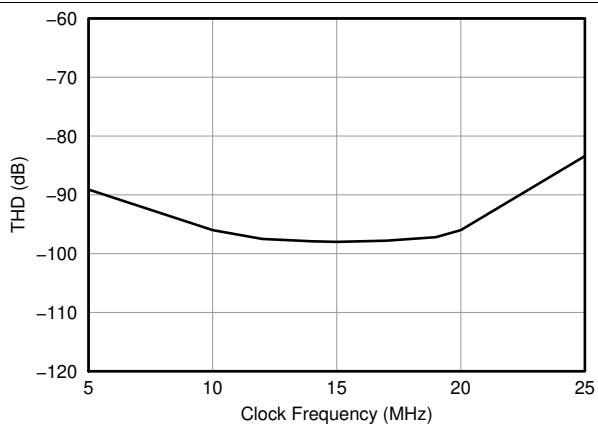

Figure 26. Total Harmonic Distortion vs Clock Frequency

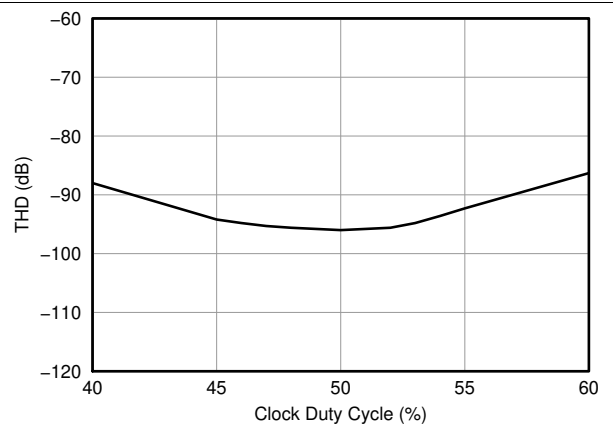

Figure 27. Total Harmonic Distortion vs Clock Duty Cycle



Typical Characteristics (continued)

at AVDD = 5 V, DVDD = 3.3 V, VINP = -250 mV to 250 mV, VINN = 0 V, and sinc<sup>3</sup> filter with OSR = 256 (unless otherwise noted)

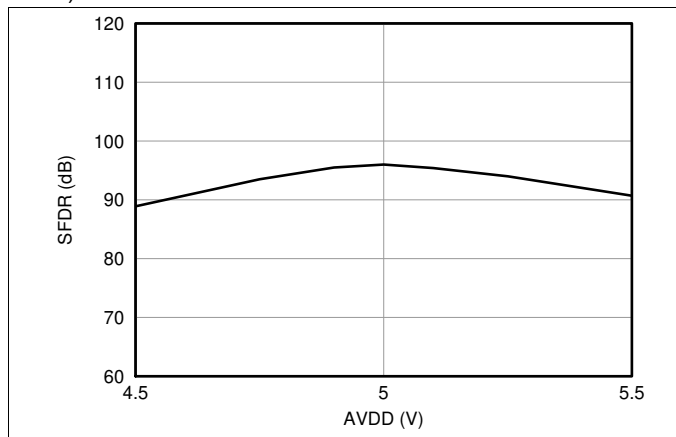

Figure 28. Spurious-Free Dynamic Range vs Analog Supply Voltage

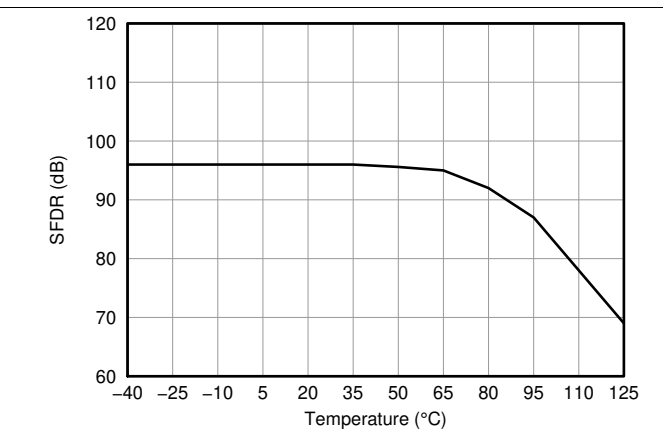

Figure 29. Spurious-Free Dynamic Range vs Temperature

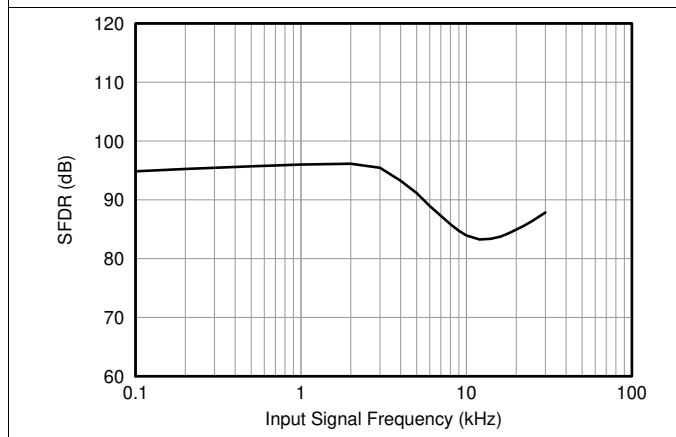

Figure 30. Spurious-Free Dynamic Range vs Input Signal Frequency

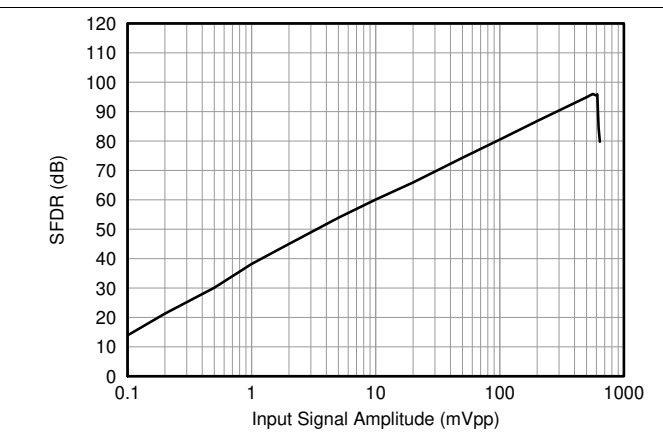

Figure 31. Spurious-Free Dynamic Range vs Input Signal Amplitude

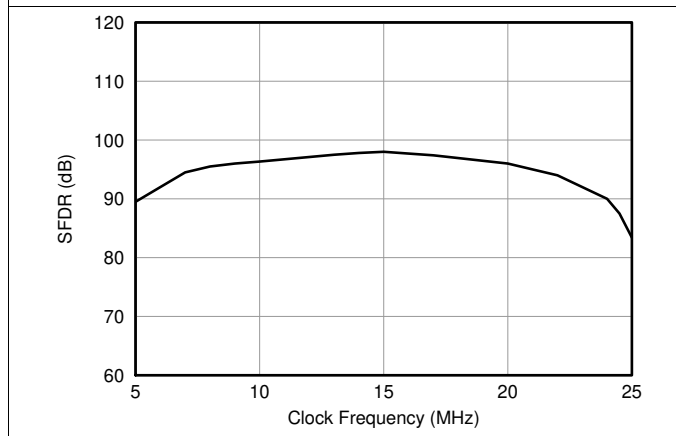

Figure 32. Spurious-Free Dynamic Range vs Clock Frequency

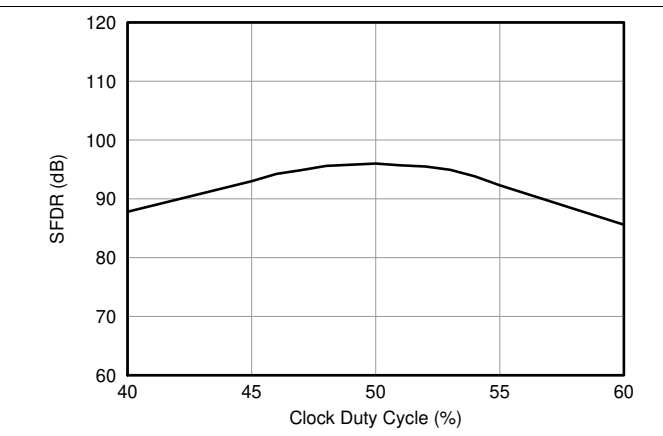

Figure 33. Spurious-Free Dynamic Range vs Clock Duty Cycle

### Typical Characteristics (continued)

at AVDD = 5 V, DVDD = 3.3 V, VINP = -250 mV to 250 mV, VINN = 0 V, and sinc<sup>3</sup> filter with OSR = 256 (unless otherwise noted)

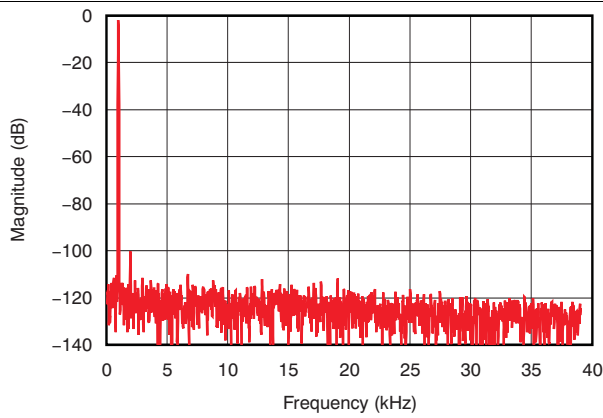

Figure 34. Frequency Spectrum (4096 Point FFT,  $f_{IN} = 1$  kHz, 0.56 V<sub>PP</sub>)

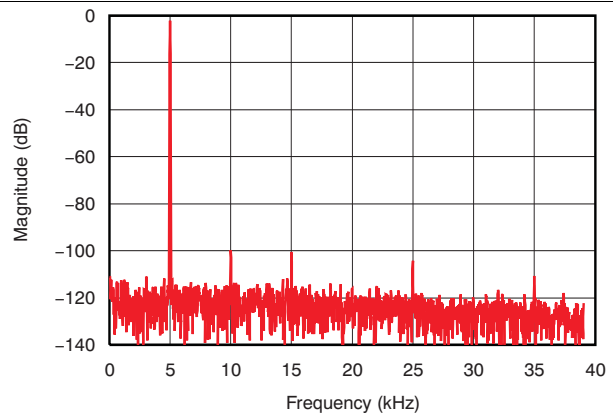

Figure 35. Frequency Spectrum (4096 Point FFT,  $f_{IN} = 5$  kHz, 0.56 V<sub>PP</sub>)

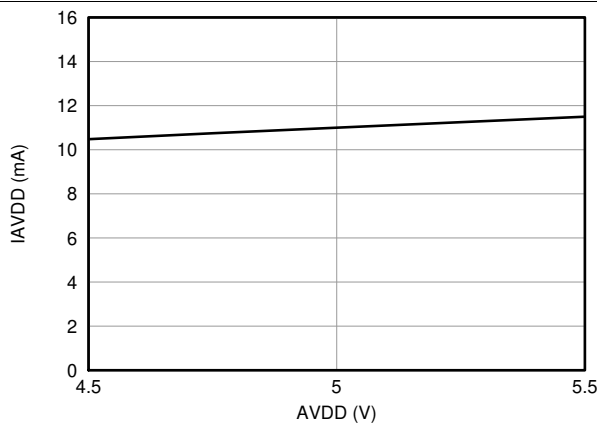

Figure 36. Analog Supply Current vs Analog Supply Voltage

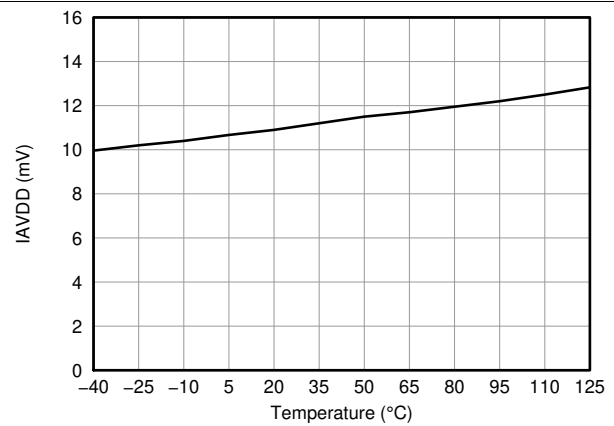

Figure 37. Analog Supply Current vs Temperature

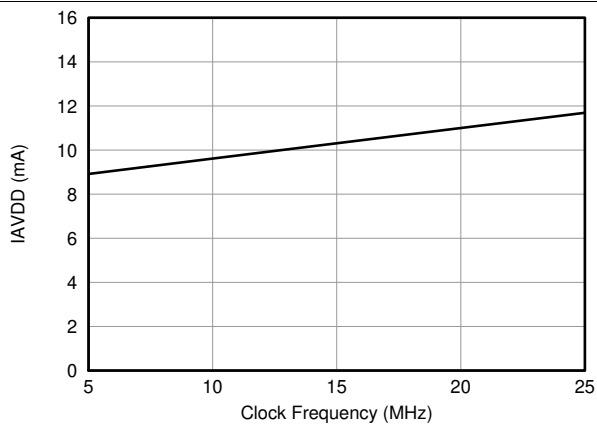

Figure 38. Analog Supply Current vs Clock Frequency

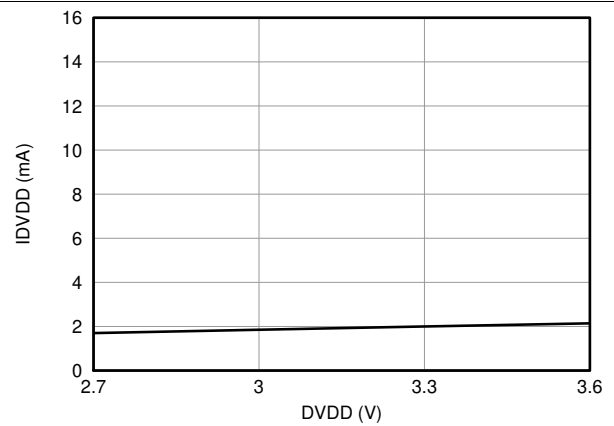

Figure 39. Digital Supply Current vs Digital Supply Voltage (3 V)

### Typical Characteristics (continued)

at AVDD = 5 V, DVDD = 3.3 V, VINP = -250 mV to 250 mV, VINN = 0 V, and sinc<sup>3</sup> filter with OSR = 256 (unless otherwise noted)

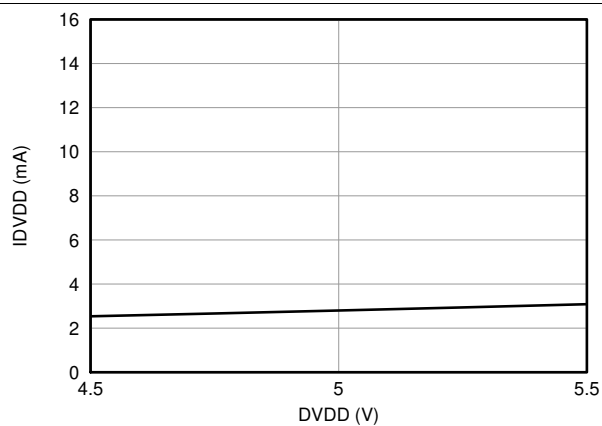

Figure 40. Digital Supply Current vs Digital Supply Voltage (5 V)

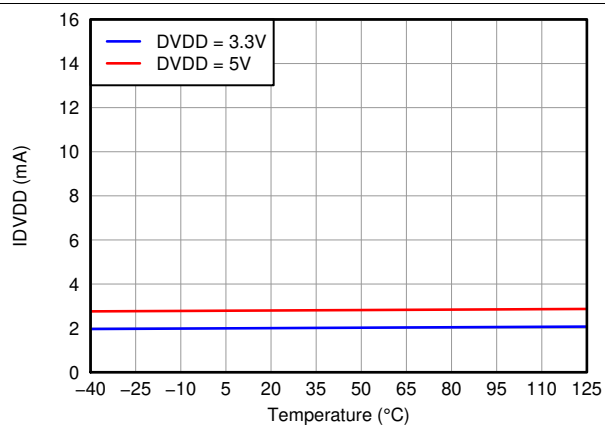

Figure 41. Digital Supply Current vs Temperature

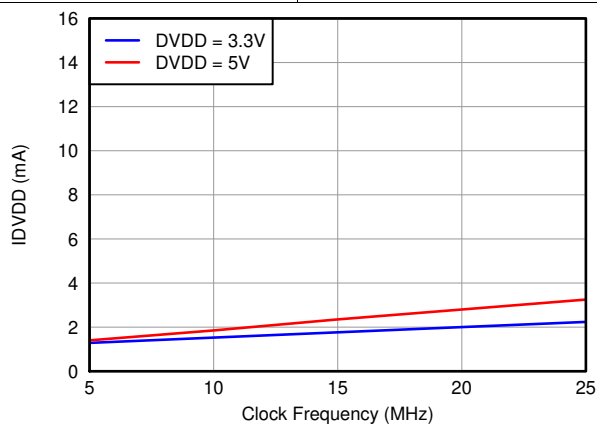

Figure 42. Digital Supply Current vs Clock Frequency

## 8 Detailed Description

### 8.1 Overview

The AMC1204 and AMC1204B are single-channel, second-order, delta-sigma ( $\Delta\Sigma$ ) modulators designed for medium- to high-resolution analog-to-digital conversions. The isolated output of the converter (DATA) provides a stream of digital ones and zeros accurately representing the analog input voltage over time. The time average of this serial output is proportional to the analog input voltage.

The *Functional Block Diagram* shows a detailed block diagram of the AMC1204 and AMC1204B. The analog input range is tailored to directly accommodate the voltage drop across a shunt resistor used for current sensing. The SiO<sub>2</sub>-based capacitive isolation barrier supports a high level of magnetic field immunity as described in the *ISO72x Digital Isolator Magnetic-Field Immunity application report*. The external clock input simplifies the synchronization of multiple current sense channels on system level. The extended frequency range of up to 20 MHz supports higher performance levels compared to the other solutions available on the market.

### 8.2 Functional Block Diagram

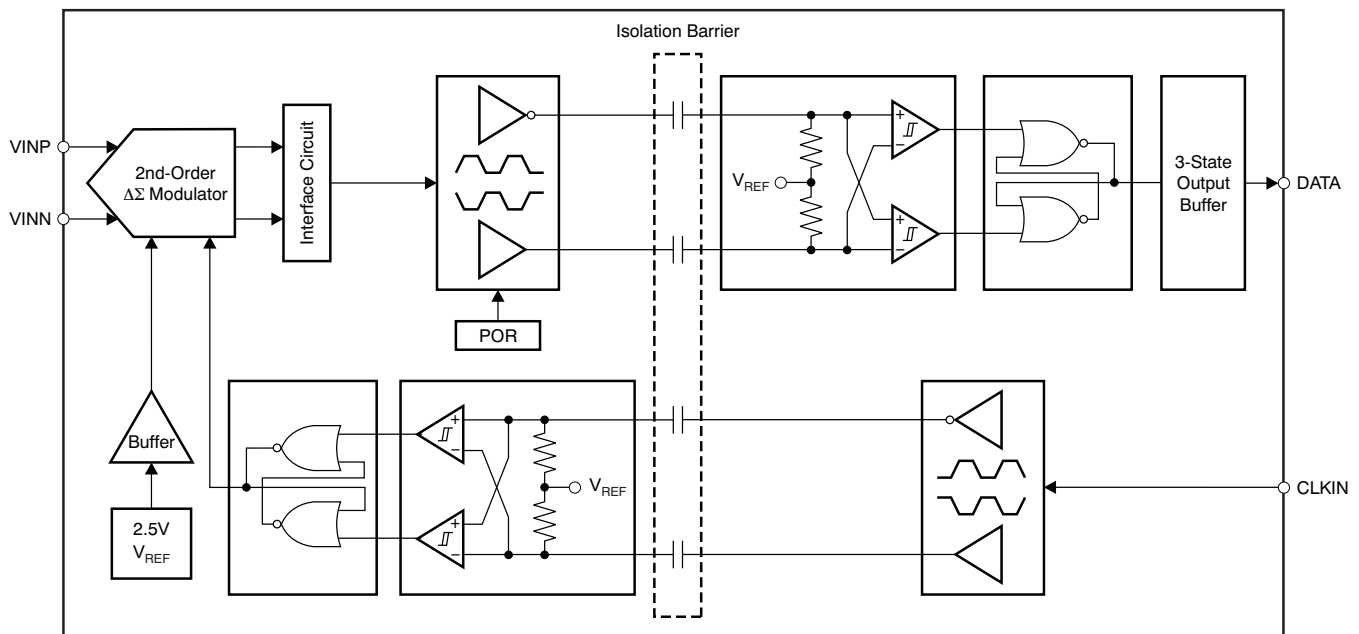

**Figure 43. Detailed Block Diagram**

## 8.3 Feature Description

### 8.3.1 Analog Input

The differential analog input of the AMC1204 and AMC1204B is implemented with a switched-capacitor circuit.

The AMC1204 and AMC1204B measure the differential input signal  $V_{IN} = (V_{INP} - V_{INN})$  against the internal reference of 2.5 V using internal capacitors that are continuously charged and discharged. Figure 44 shows the simplified schematic of the AMC1204 and AMC1204B input circuitry; the right side of Figure 44 illustrates the input circuitry with the capacitors and switches replaced by an equivalent circuit.

In Figure 44, the  $S_1$  switches close during the input sampling phase. With the  $S_1$  switches closed,  $C_{DIFF}$  charges to the voltage difference across  $V_{INP}$  and  $V_{INN}$ . For the discharge phase, both  $S_1$  switches open first and then both  $S_2$  switches close.  $C_{DIFF}$  discharges approximately to  $AGND + 0.8\text{ V}$  during this phase. This two-phase sample/discharge cycle repeats with a period of  $t_{CLKIN} = 1/f_{CLKIN}$ .  $f_{CLKIN}$  is the operating frequency of the modulator. The capacitors  $C_{IP}$  and  $C_{IN}$  are of parasitic nature and caused by bonding wires and the internal ESD protection structure.

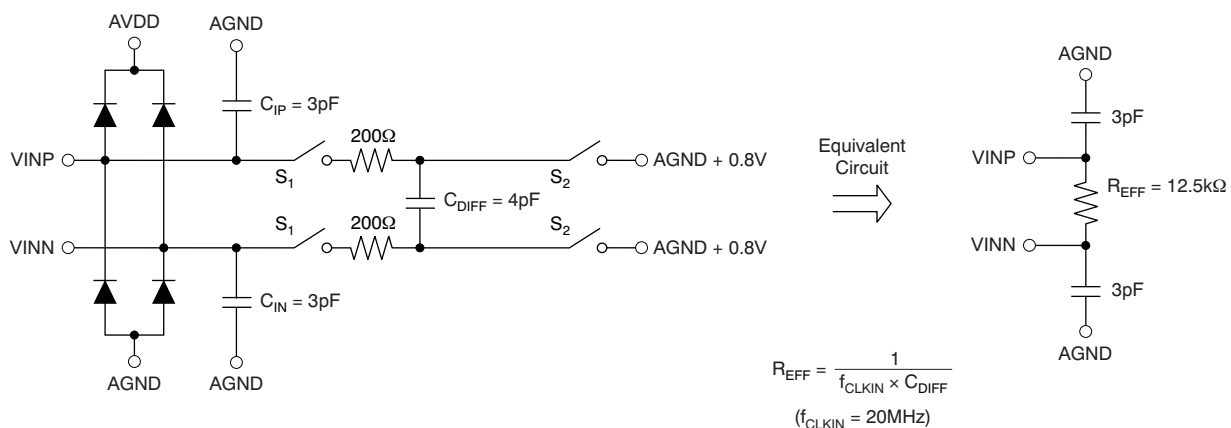
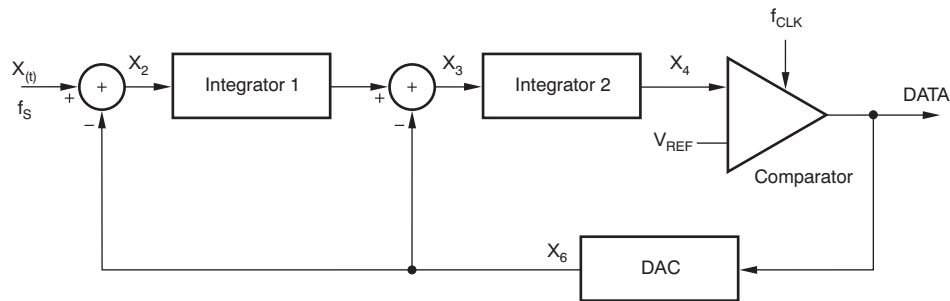

Figure 44. Equivalent Analog Input Circuit

There are two restrictions on the analog input signals  $V_{INP}$  and  $V_{INN}$ . First, if the input voltage exceeds the range  $AGND - 0.5\text{ V}$  to  $AVDD + 0.3\text{ V}$ , the input current must be limited to 10 mA because the input protection diodes on the front end of the converter begin to turn on. In addition, the linearity and the noise performance of the device are ensured only when the differential analog input voltage remains within  $\pm 250\text{ mV}$ .

### 8.3.2 Modulator

The modulator topology of the AMC1204 and AMC1204B is fundamentally a second-order, switched-capacitor,  $\Delta\Sigma$  modulator, such as the one conceptualized in Figure 45. The analog input voltage ( $X_{(t)}$ ) and the output of the 1-bit digital-to-analog converter (DAC) are differentiated, providing an analog voltage ( $X_2$ ) at the input of the first integrator or modulator stage. The output of the first integrator is further differentiated with the DAC output; the resulting voltage ( $X_3$ ) feeds the input of the second integrator stage. When the value of the integrated signal ( $X_4$ ) at the output of the second stage equals the comparator reference voltage, the output of the comparator switches from high to low, or vice versa, depending on its previous state. In this case, the 1-bit DAC responds on the next clock pulse by changing its analog output voltage ( $X_6$ ), causing the integrators to progress in the opposite direction, while forcing the value of the integrator output to track the average of the input.

**Feature Description (continued)**

**Figure 45. Block Diagram Of A Second-Order Modulator**

The modulator shifts the quantization noise to high frequencies, as shown in [Figure 46](#); therefore, a low-pass digital filter should be used at the output of the device to increase the overall performance. This filter is also used to convert from the 1-bit data stream at a high sampling rate into a higher-bit data word at a lower rate (decimation). A digital signal processor (DSP), microcontroller ( $\mu$ C), or field programmable gate array (FPGA) can be used to implement the filter.

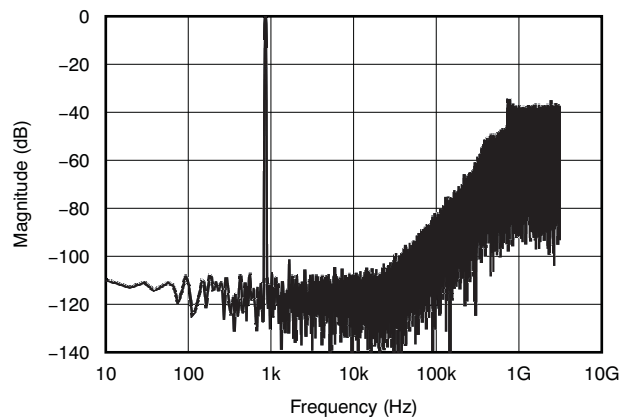
TI's microcontroller family [TMS320F28x7x](#) offers a suitable programmable, hardwired filter structure termed a *sigma-delta filter module* (SDFM) optimized for usage with the AMC1204, AMC1304 and AMC1305 devices. Also, the SD24\_B converters on the [MSP430F677x](#) microcontrollers offer a path to directly access the integrated sinc-filters, thus offering a system-level solution for multichannel isolated current sensing. Another option is to use a suitable application-specific device such as the [AMC1210](#), a four-channel digital sinc-filter.

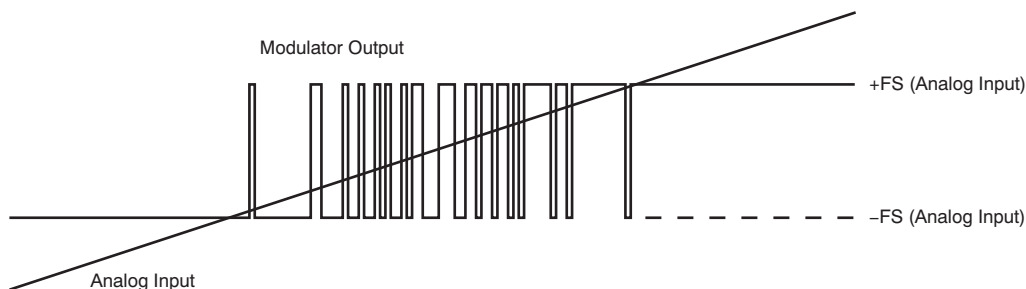

**Figure 46. Quantization Noise Shaping**

## Feature Description (continued)

### 8.3.3 Digital Output

A differential input signal of 0 V ideally produces a stream of ones and zeros that are high 50% of the time and low 50% of the time. A differential input of 250 mV produces a stream of ones and zeros that are high 89.06% of the time. A differential input of –250 mV produces a stream of ones and zeros that are high 10.94% of the time. This is also the specified linear input range of the modulator with the performance as specified in this data sheet. The range between 250 mV and 320 mV (absolute values) is the non-linear range of the modulator. The output of the modulator clips with a stream of only zeros with an input less than or equal to –320 mV or with a stream of only ones with an input greater than or equal to 320 mV. The input voltage versus the output modulator signal is shown in [Figure 47](#).

The system clock of the AMC1204 and AMC1204B is typically 20 MHz and is provided externally at the CLKIN pin. The data are synchronously provided at 20 MHz at the DATA output pin. The data are changing at the falling edge of CLKIN; for more details see the [Timing Requirements](#) section.



**Figure 47. Analog Input Versus Amc1204 Modulator Output**

## 8.4 Device Functional Modes

The AMC1204 is operational when the power supplies AVDD and DVDD are applied as specified in the [Recommended Operating Conditions](#) section.

The AMC1204 has no additional functional modes.

## 9 Application and Implementation

### NOTE

Information in the following applications sections is not part of the TI component specification, and TI does not warrant its accuracy or completeness. TI's customers are responsible for determining suitability of components for their purposes. Customers should validate and test their design implementation to confirm system functionality.

### 9.1 Application Information

#### 9.1.1 Digital Filter Usage

The modulator generates a bit stream that is processed by a digital filter to obtain a digital word similar to a conversion result of a conventional analog-to-digital converter (ADC). A very simple filter, built with minimal effort and hardware, is a sinc<sup>3</sup>-type filter, as shown in Equation 1:

$$H(z) = \left( \frac{1 - z^{-OSR}}{1 - z^{-1}} \right)^3 \tag{1}$$

This filter provides the best output performance at the lowest hardware size (count of digital gates). For an oversampling rate (OSR) in the range of 16 to 256, this filter is a good choice. All the characterization in this document is also done with a sinc<sup>3</sup> filter with OSR = 256 and an output word width of 16 bits.

In a sinc<sup>3</sup> filter response (shown in Figure 48 and Figure 49), the location of the first notch occurs at the frequency of output data rate  $f_{DATA} = f_{CLK}/OSR$ . The -3-dB point is located at half the Nyquist frequency or  $f_{DATA}/4$ . For some applications, it may be necessary to use another filter type with different frequency response. Performance can be improved, for example, by using a cascaded filter structure. The first decimation stage could be built of a sinc<sup>3</sup> filter with a low OSR and the second stage using a high-order filter.

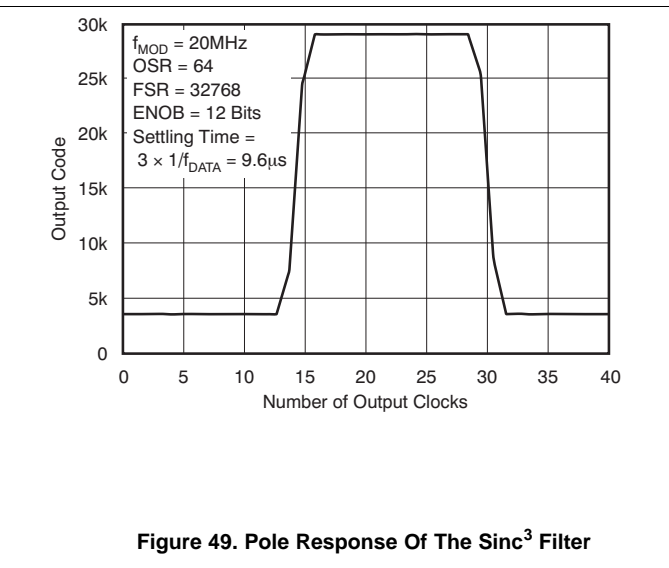
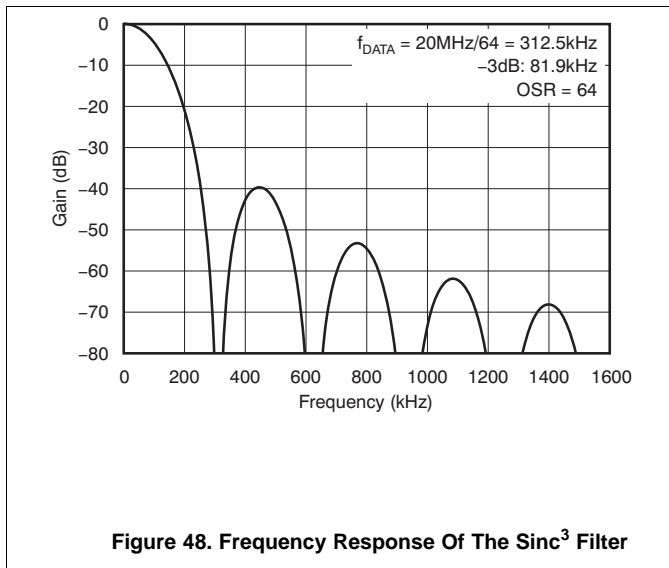

The effective number of bits (ENOB) is often used to compare the performance of ADCs and  $\Delta\Sigma$  modulators. Figure 51 illustrates the ENOB of the AMC1204 and AMC1204B with different oversampling ratios. In this data sheet, this number is calculated from SNR using Equation 2:

$$SNR = 1.76dB + 6.02dB \times ENOB \tag{2}$$

An example code for an implementation of a sinc<sup>3</sup> filter in an FPGA follows. For more information, see the [Combining ADS1202 with FPGA Digital Filter for Current Measurement in Motor Control Applications application note](#), available for download at [www.ti.com](http://www.ti.com).



## Application Information (continued)

```

library IEEE;
use IEEE.std_logic_1164.all;
use IEEE.std_logic_unsigned.all;

entity FLT is
    port(RESN, MOUT, MCLK, CNR : in std_logic;
         CN5 : out std_logic_vector(23 downto 0));
end FLT;

architecture RTL of FLT is
    signal DN0, DN1, DN3, DN5 : std_logic_vector(23 downto 0);
    signal CN1, CN2, CN3, CN4 : std_logic_vector(23 downto 0);
    signal DELTA1 : std_logic_vector(23 downto 0);
begin

    process(MCLK, RESn)
    begin
        if RESn = '0' then
            DELTA1 <= (others => '0');
        elsif MCLK'event and MCLK = '1' then
            if MOUT = '1' then
                DELTA1 <= DELTA1 + 1;
            end if;
        end if;
    end process;

    process(RESN, MCLK)
    begin
        if RESN = '0' then
            CN1 <= (others => '0');
            CN2 <= (others => '0');
        elsif MCLK'event and MCLK = '1' then
            CN1 <= CN1 + DELTA1;
            CN2 <= CN2 + CN1;
        end if;
    end process;

    process(RESN, CNR)
    begin
        if RESN = '0' then
            DN0 <= (others => '0');
            DN1 <= (others => '0');
            DN3 <= (others => '0');
            DN5 <= (others => '0');
        elsif CNR'event and CNR = '1' then
            DN0 <= CN2;
            DN1 <= DN0;
            DN3 <= CN3;
            DN5 <= CN4;
        end if;
    end process;

    CN3 <= DN0 - DN1;
    CN4 <= CN3 - DN3;
    CN5 <= CN4 - DN5;

end RTL;
    
```

## 9.2 Typical Application

### 9.2.1 Frequency Inverter Application

Because of their high AC and DC performance, isolated  $\Delta\Sigma$  modulators are being widely used in new generation frequency inverter designs. Frequency inverters are critical parts of industrial motor drives, photovoltaic inverters (string and central inverters), uninterruptible power supplies (UPS), electrical and hybrid vehicles, and other industrial applications. The input structure of the AMC1204 is optimized for use with low-impedance shunt resistors and is therefore tailored for isolated current sensing using shunts.

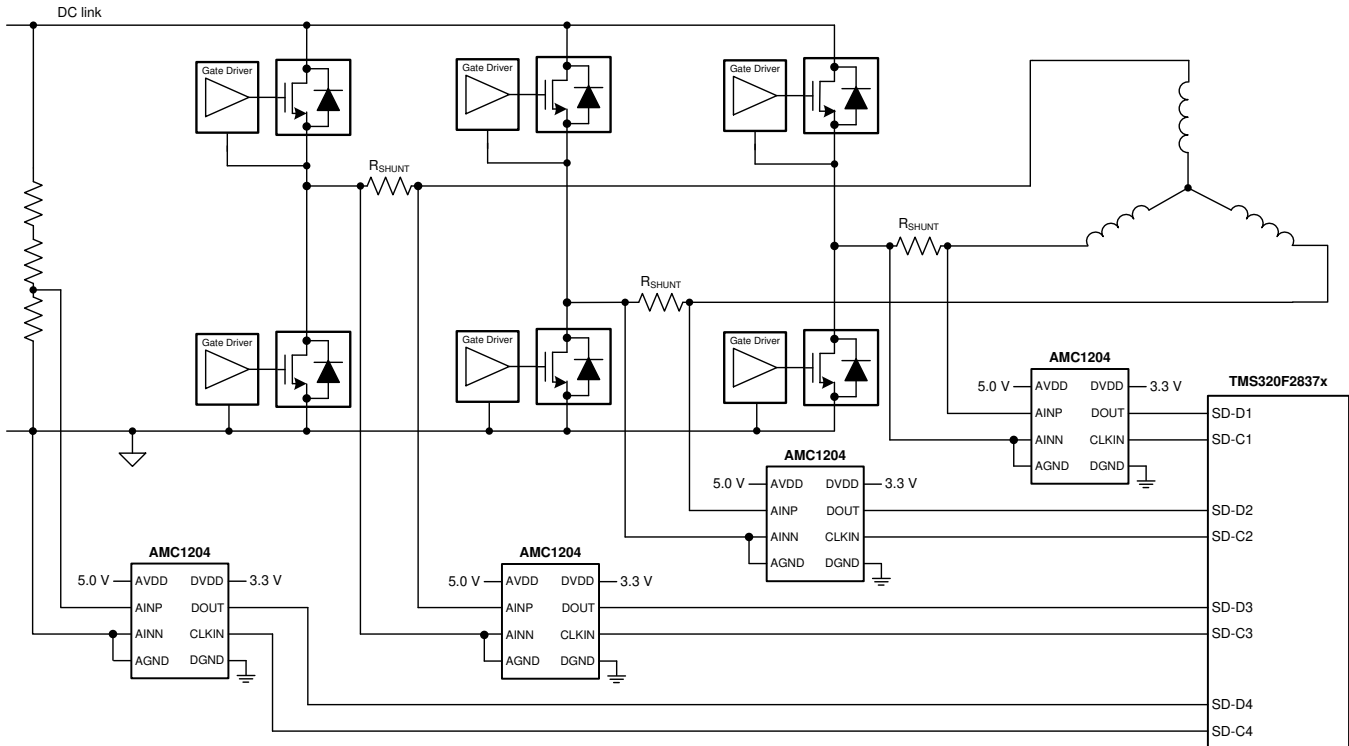

Figure 50. AMC1204 in a Frequency Inverter Application

#### 9.2.1.1 Design Requirements

Figure 50 shows a diagram of the AMC1204 in a typical frequency inverter. When the inverter stage is part of a motor drive system, measurement of the motor phase current is done via the shunt resistors ( $R_{SHUNT}$ ). Depending on the system design, either all three or only two phase currents are sensed.

In this example, an additional AMC1204 is used for isolated sensing of the DC link voltage. This high DC link voltage is reduced using a high-impedance resistive divider before being sensed by the AMC1204 across a smaller resistor. It is important to consider that the value of the resistor in the voltage divider can potentially degrade the performance of the measurement. Such phenomenon is described in the [Isolated Voltage Sensing](#) section.

#### 9.2.1.2 Detailed Design Procedure

For modulator output bit-stream filtering, TI recommends a device from TI's [TMS320F28x7x](#) family of MCUs. This family supports up to eight channels of dedicated hardwired filter structures that significantly simplify system level design by offering two filtering paths per channel: one providing high accuracy results for the control loop and one fast response path for overcurrent detection.

**Typical Application (continued)**

**9.2.1.3 Application Curves**

In motor control applications, a very fast response time for overcurrent detection is required. The time for fully settling the filter in case of a step-signal at the input of the modulator depends on its order; that is, a sinc<sup>3</sup> filter requires three data updates for full settling (with f<sub>DATA</sub> = f<sub>CLK</sub> / OSR). Therefore, for overcurrent protection, filter types other than sinc<sup>3</sup> might be better choices. An alternative is, for example, the sinc<sup>2</sup> filter. Figure 52 compares the settling times of different filter orders.

Sincfast is a modified sinc<sup>2</sup> filter whose transfer function follows Equation 3.

$$H(z) = \left( \frac{1 - z^{-OSR}}{1 - z^{-1}} \right)^2 (1 + z^{-2OSR}) \tag{3}$$

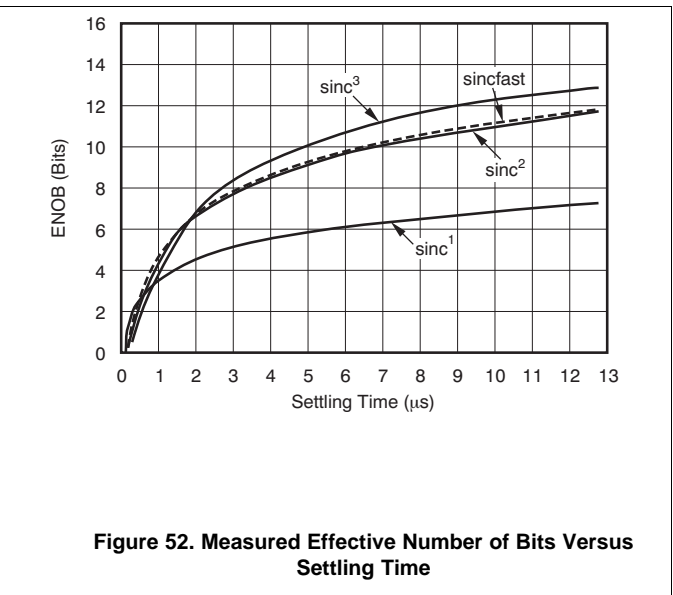
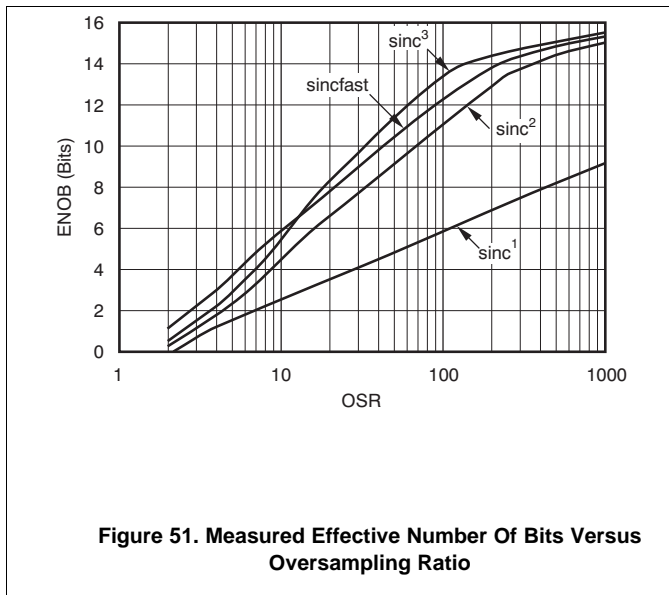

In the case of a continuous signal fed into a sinc filter, the time delay for such signal corresponds to half of the settling time shown in Figure 52.

Typical Application (continued)

9.2.2 Example of a Resolver-Based Motor Control Analog Front End

Figure 53 shows an example of two AMC1204 and AMC1204B devices and one ADS1209 (a dual-channel, 10-MHz, non-isolated modulator) connected to an AMC1210, building the entire analog front end of a resolver-based motor control application.

For detailed information on the ADS1209 and AMC1210, visit the respective device product folders at www.ti.com.

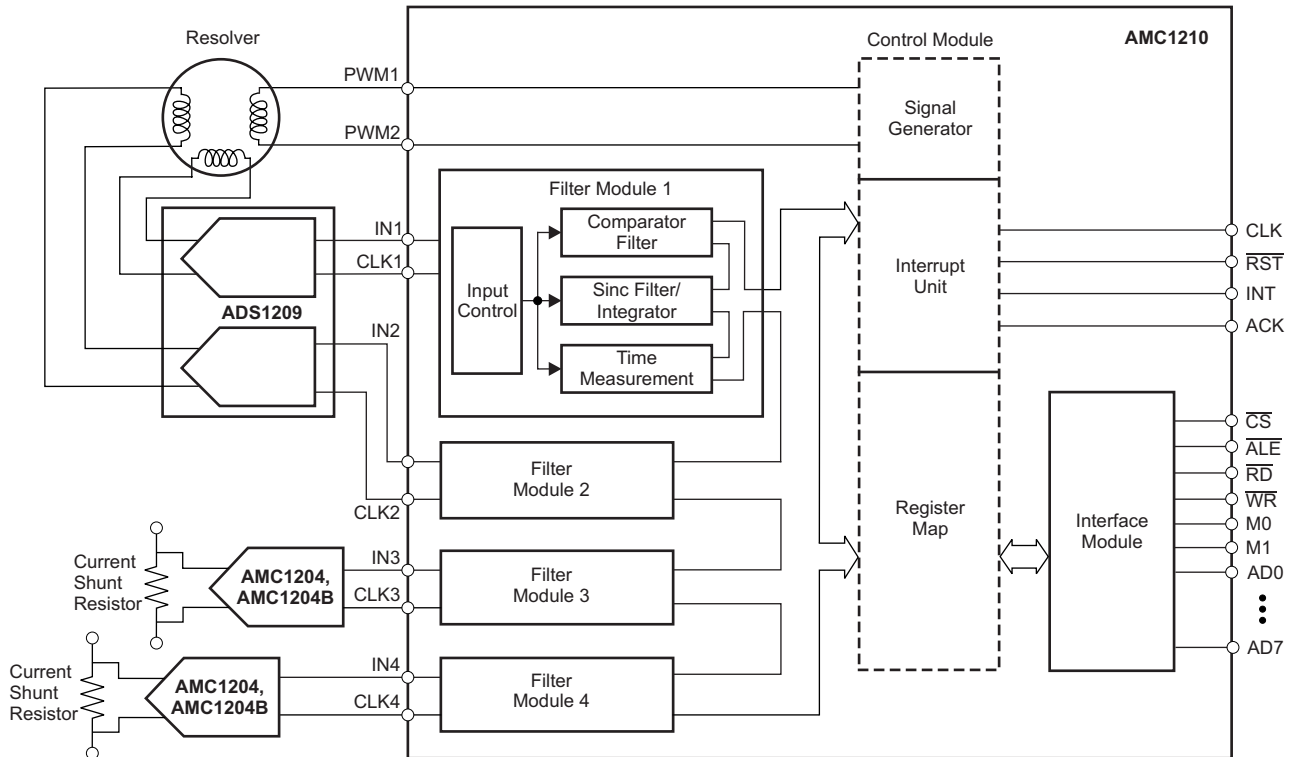

Figure 53. Example of a Resolver-Based Motor Control Analog Front End Schematic

9.2.3 Isolated Voltage Sensing

The AMC1204 is optimized for current-sensing applications using low-impedance shunts. However, the device can also be used in isolated voltage-sensing applications if the impact of the (usually higher) impedance of the resistor used in this case is considered. Figure 54 shows a simplified circuit typically used in high-voltage sensing applications.

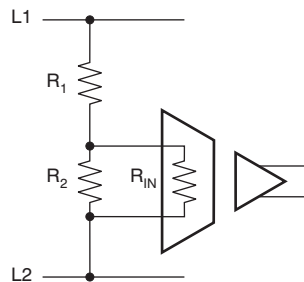

Figure 54. Voltage Measurement Application

## Typical Application (continued)

### 9.2.3.1 Design Requirements

In such applications, a resistor divider ( $R_1$  and  $R_2$ ) is used to match the relatively small input voltage range of the AMC device.  $R_2$  and the input resistance  $R_{IN}$  of the AMC1204 also create a resistor divider resulting in additional gain error. With the assumption that  $R_1$  and  $R_{IN}$  have a considerably higher value than  $R_2$ , use Equation 4 to estimate the resulting total gain error.

$$G_{ERRTOT} = G_{ERR} + \frac{R_2}{R_{IN}}$$

where

- $G_{ERR}$  = the gain error of AMC device. (4)

## 10 Power Supply Recommendations

In a typical frequency inverter application, the high-side power supply (AVDD) for the AMC1204 and AMC1204B is derived from the power supply of the upper gate driver. For lowest cost, a Zener diode can be used to limit the voltage to  $5\text{ V} \pm 10\%$ . TI recommends a decoupling capacitor of  $0.1\ \mu\text{F}$  for filtering this power-supply path. This capacitor ( $C_1$  in Figure 55) should be placed as close as possible to the AVDD pin for best performance. If better filtering is required, an additional  $1\text{-}\mu\text{F}$  to  $10\text{-}\mu\text{F}$  capacitor can be used. The floating ground reference AGND is derived from the end of the shunt resistor, which is connected to the negative input (VINN) of the AMC1204 and AMC1204B. If a four-terminal shunt is used, the inputs of AMC1204 and AMC1204B are connected to the inner leads, while AGND is connected to one of the outer leads of the shunt. Both digital signals, CLKIN and DATA, can be directly connected to a digital filter.

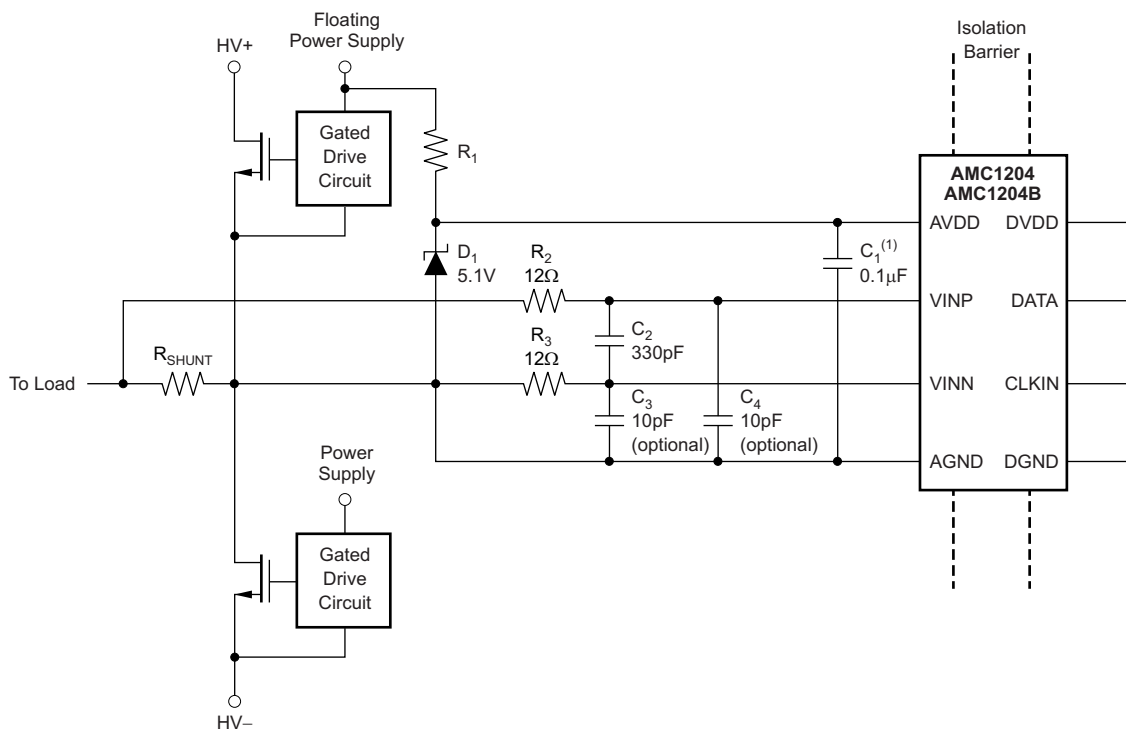

(1) Place  $C_1$  close to the AMC1204 and AMC1204B.

**Figure 55. Zener-Diode-Based High-Side Power Supply**

For better performance, the differential input signal is filtered using RC filters (components  $R_2$ ,  $R_3$ , and  $C_2$ ). Optionally,  $C_3$  and  $C_4$  can be used to reduce charge dumping from the inputs. In this case, care should be taken when choosing the quality of these capacitors: any mismatch in the capacitor values can cause a common-mode error at the input of the modulator.

## 11 Layout

### 11.1 Layout Guidelines

- Place the decoupling capacitors for AVDD and DVDD as close as possible to the AMC1204.
- Ensure that the traces that connect the shunt resistor to the RC filter on the VINP terminal are symmetrical to and have the same length as the traces connecting to the VINN terminal.
- The top and bottom PCB layers underneath the AMC1204 must be kept free of any conductive materials in order to comply with the creepage and clearance distances shown in the section.

### 11.2 Layout Example

Figure 56 shows the recommended layout and placement of the decoupling capacitors and other components required by the AMC1204 and AMC1204B.

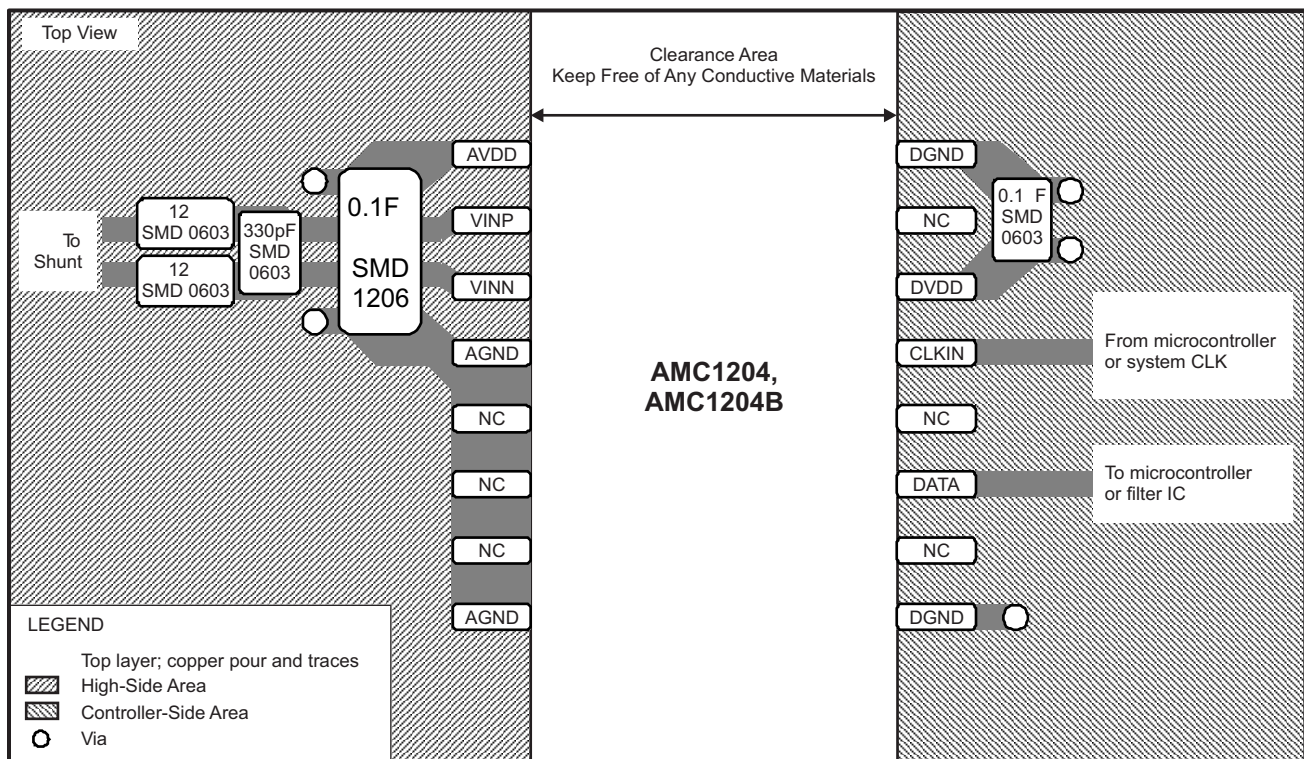

Figure 56. Recommended Layout

## 12 デバイスおよびドキュメントのサポート

### 12.1 ドキュメントのサポート

#### 12.1.1 関連資料

関連資料については、以下を参照してください。

- テキサス・インスツルメンツ、『[TMS320F2837xD デュアル・コアDelfino™マイクロコントローラ](#)』データシート
- テキサス・インスツルメンツ、『[MSP430F677x, MSP430F676x, MSP430F674x 多相メータリング SoC](#)』データシート
- テキサス・インスツルメンツ、『[TMS320F2837xD デュアル・コアDelfino™マイクロコントローラ](#)』データシート
- テキサス・インスツルメンツ、『[AMC1210 2次デルタ-シグマ変調器用のクワッド・デジタル・フィルタ](#)』データシート
- テキサス・インスツルメンツ、『[ADS1209 Two 1-Bit, 10MHz, 2nd-Order Delta-Sigma Modulators](#)』データシート (英語)
- テキサス・インスツルメンツ、『[ISO72x デジタルアイソレータ磁界耐性](#)』アプリケーション・レポート
- テキサス・インスツルメンツ、『[Combining the ADS1202 with an FPGA Digital Filter for Current Measurement in Motor Control Applications](#)』アプリケーション・レポート (英語)
- テキサス・インスツルメンツ、『[絶縁の用語集](#)』アプリケーション・レポート

### 12.2 ドキュメントの更新通知を受け取る方法

ドキュメントの更新についての通知を受け取るには、[ti.com](http://ti.com)のデバイス製品フォルダを開いてください。右上の「アラートを受け取る」をクリックして登録すると、変更されたすべての製品情報に関するダイジェストを毎週受け取れます。変更の詳細については、修正されたドキュメントに含まれている改訂履歴をご覧ください。

### 12.3 サポート・リソース

[TI E2E™ support forums](#) are an engineer's go-to source for fast, verified answers and design help — straight from the experts. Search existing answers or ask your own question to get the quick design help you need.

Linked content is provided "AS IS" by the respective contributors. They do not constitute TI specifications and do not necessarily reflect TI's views; see TI's [Terms of Use](#).

### 12.4 商標

E2E is a trademark of Texas Instruments.

All other trademarks are the property of their respective owners.

### 12.5 静電気放電に関する注意事項



すべての集積回路は、適切なESD保護方法を用いて、取扱いと保存を行うようにして下さい。

静電気放電はわずかな性能の低下から完全なデバイスの故障に至るまで、様々な損傷を与えます。高精度の集積回路は、損傷に対して敏感であり、極めてわずかなパラメータの変化により、デバイスに規定された仕様に適合しなくなる場合があります。

### 12.6 Glossary

[SLYZ022](#) — *TI Glossary*.

This glossary lists and explains terms, acronyms, and definitions.

## 13 メカニカル、パッケージ、および注文情報

以降のページには、メカニカル、パッケージ、および注文に関する情報が記載されています。この情報は、そのデバイスについて利用可能な最新のデータです。このデータは予告なく変更されることがあり、ドキュメントが改訂される場合もあります。本データシートのブラウザ版を使用されている場合は、画面左側の説明をご覧ください。

## PACKAGING INFORMATION

Orderable Device	Status (1)	Package Type	Package Drawing	Pins	Package Qty	Eco Plan (2)	Lead finish/ Ball material (6)	MSL Peak Temp (3)	Op Temp (°C)	Device Marking (4/5)	Samples
AMC1204BDW	ACTIVE	SOIC	DW	16	40	RoHS & Green	NIPDAU	Level-3-260C-168 HR	-40 to 125	1204B	<a href="#">Samples</a>
AMC1204BDWR	ACTIVE	SOIC	DW	16	2000	RoHS & Green	NIPDAU	Level-3-260C-168 HR	-40 to 125	1204B	<a href="#">Samples</a>
AMC1204BDWV	ACTIVE	SOIC	DWV	8	64	RoHS & Green	SN	Level-3-260C-168 HR	-40 to 125	AMC1204B	<a href="#">Samples</a>
AMC1204BDWVR	ACTIVE	SOIC	DWV	8	1000	RoHS & Green	Call TI   SN	Level-3-260C-168 HR	-40 to 125	AMC1204B	<a href="#">Samples</a>
AMC1204DW	ACTIVE	SOIC	DW	16	40	RoHS & Green	NIPDAU	Level-3-260C-168 HR	-40 to 125	AMC1204	<a href="#">Samples</a>
AMC1204DWR	ACTIVE	SOIC	DW	16	2000	RoHS & Green	NIPDAU	Level-3-260C-168 HR	-40 to 125	AMC1204	<a href="#">Samples</a>

(1) The marketing status values are defined as follows:

**ACTIVE:** Product device recommended for new designs.

**LIFEBUY:** TI has announced that the device will be discontinued, and a lifetime-buy period is in effect.

**NRND:** Not recommended for new designs. Device is in production to support existing customers, but TI does not recommend using this part in a new design.

**PREVIEW:** Device has been announced but is not in production. Samples may or may not be available.

**OBSELETE:** TI has discontinued the production of the device.

(2) **RoHS:** TI defines "RoHS" to mean semiconductor products that are compliant with the current EU RoHS requirements for all 10 RoHS substances, including the requirement that RoHS substance do not exceed 0.1% by weight in homogeneous materials. Where designed to be soldered at high temperatures, "RoHS" products are suitable for use in specified lead-free processes. TI may reference these types of products as "Pb-Free".

**RoHS Exempt:** TI defines "RoHS Exempt" to mean products that contain lead but are compliant with EU RoHS pursuant to a specific EU RoHS exemption.

**Green:** TI defines "Green" to mean the content of Chlorine (Cl) and Bromine (Br) based flame retardants meet JS709B low halogen requirements of <=1000ppm threshold. Antimony trioxide based flame retardants must also meet the <=1000ppm threshold requirement.

(3) MSL, Peak Temp. - The Moisture Sensitivity Level rating according to the JEDEC industry standard classifications, and peak solder temperature.

(4) There may be additional marking, which relates to the logo, the lot trace code information, or the environmental category on the device.

(5) Multiple Device Markings will be inside parentheses. Only one Device Marking contained in parentheses and separated by a "~" will appear on a device. If a line is indented then it is a continuation of the previous line and the two combined represent the entire Device Marking for that device.

(6) Lead finish/Ball material - Orderable Devices may have multiple material finish options. Finish options are separated by a vertical ruled line. Lead finish/Ball material values may wrap to two lines if the finish value exceeds the maximum column width.



**Important Information and Disclaimer:** The information provided on this page represents TI's knowledge and belief as of the date that it is provided. TI bases its knowledge and belief on information provided by third parties, and makes no representation or warranty as to the accuracy of such information. Efforts are underway to better integrate information from third parties. TI has taken and continues to take reasonable steps to provide representative and accurate information but may not have conducted destructive testing or chemical analysis on incoming materials and chemicals. TI and TI suppliers consider certain information to be proprietary, and thus CAS numbers and other limited information may not be available for release.

In no event shall TI's liability arising out of such information exceed the total purchase price of the TI part(s) at issue in this document sold by TI to Customer on an annual basis.

**OTHER QUALIFIED VERSIONS OF AMC1204 :**

- Automotive : [AMC1204-Q1](#)

NOTE: Qualified Version Definitions:

- Automotive - Q100 devices qualified for high-reliability automotive applications targeting zero defects

**TAPE AND REEL INFORMATION**

**QUADRANT ASSIGNMENTS FOR PIN 1 ORIENTATION IN TAPE**

\*All dimensions are nominal

Device	Package Type	Package Drawing	Pins	SPQ	Reel Diameter (mm)	Reel Width W1 (mm)	A0 (mm)	B0 (mm)	K0 (mm)	P1 (mm)	W (mm)	Pin1 Quadrant
AMC1204BDWR	SOIC	DW	16	2000	330.0	16.4	10.75	10.7	2.7	12.0	16.0	Q1
AMC1204BDWVR	SOIC	DWV	8	1000	330.0	16.4	12.05	6.15	3.3	16.0	16.0	Q1
AMC1204DWR	SOIC	DW	16	2000	330.0	16.4	10.75	10.7	2.7	12.0	16.0	Q1
AMC1204DWR	SOIC	DW	16	2000	330.0	16.4	10.75	10.7	2.7	12.0	16.0	Q1

**TAPE AND REEL BOX DIMENSIONS**

\*All dimensions are nominal

Device	Package Type	Package Drawing	Pins	SPQ	Length (mm)	Width (mm)	Height (mm)
AMC1204BDWR	SOIC	DW	16	2000	356.0	356.0	35.0
AMC1204BDWVR	SOIC	DWV	8	1000	350.0	350.0	43.0
AMC1204DWR	SOIC	DW	16	2000	350.0	350.0	43.0
AMC1204DWR	SOIC	DW	16	2000	356.0	356.0	35.0

**TUBE**

\*All dimensions are nominal

Device	Package Name	Package Type	Pins	SPQ	L (mm)	W (mm)	T (μm)	B (mm)
AMC1204BDW	DW	SOIC	16	40	507	12.83	5080	6.6
AMC1204BDW	DW	SOIC	16	40	506.98	12.7	4826	6.6
AMC1204BDWV	DWV	SOIC	8	64	505.46	13.94	4826	6.6
AMC1204DW	DW	SOIC	16	40	507	12.83	5080	6.6
AMC1204DW	DW	SOIC	16	40	506.98	12.7	4826	6.6

# PACKAGE OUTLINE

DWV0008A



SOIC - 2.8 mm max height

SOIC

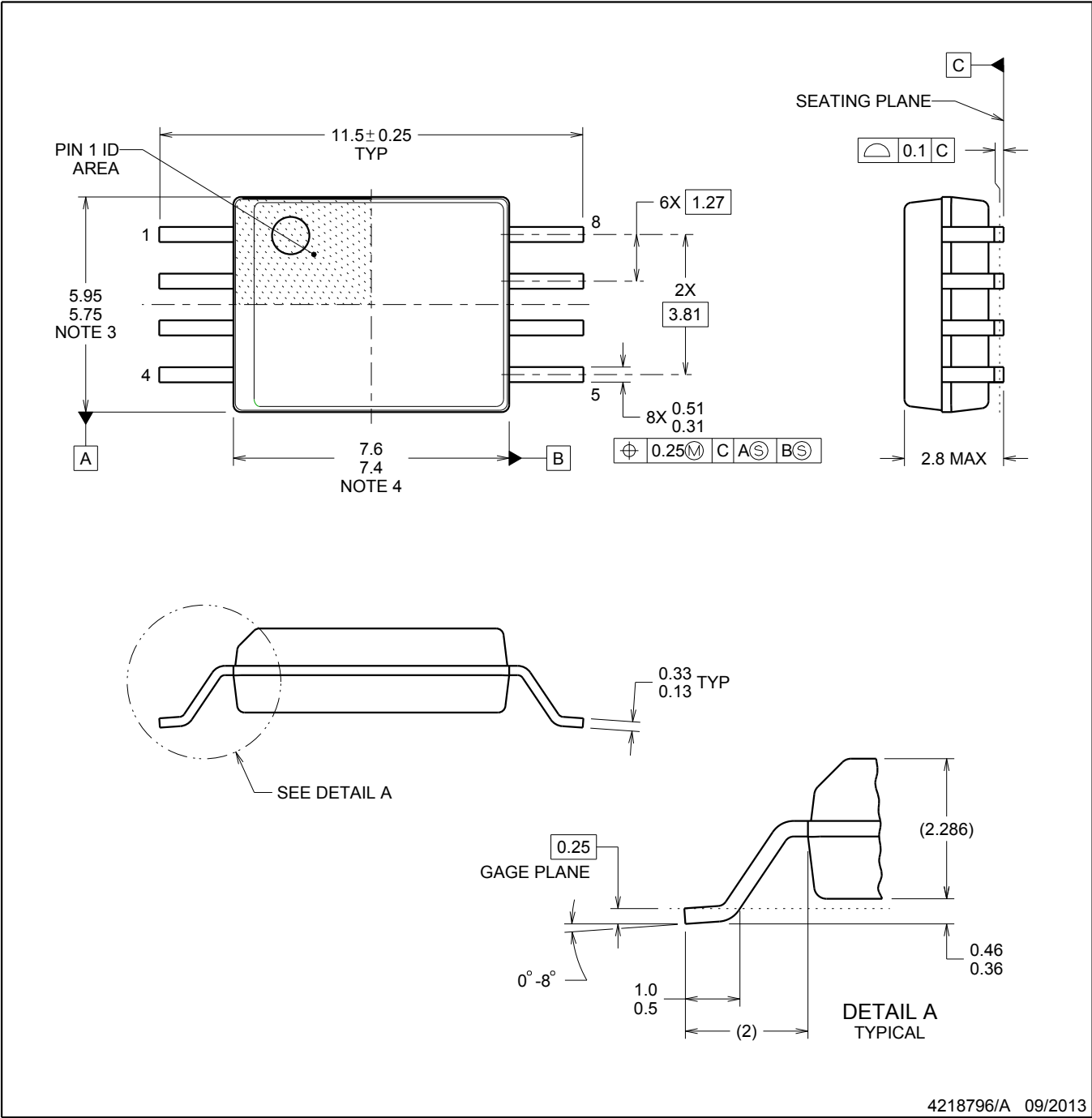

4218796/A 09/2013

**NOTES:**

1. All linear dimensions are in millimeters. Dimensions in parenthesis are for reference only. Dimensioning and tolerancing per ASME Y14.5M.
2. This drawing is subject to change without notice.
3. This dimension does not include mold flash, protrusions, or gate burrs. Mold flash, protrusions, or gate burrs shall not exceed 0.15 mm, per side.
4. This dimension does not include interlead flash. Interlead flash shall not exceed 0.25 mm, per side.



LAND PATTERN EXAMPLE  
 9.1 mm NOMINAL CLEARANCE/CREEPAGE  
 SCALE:6X

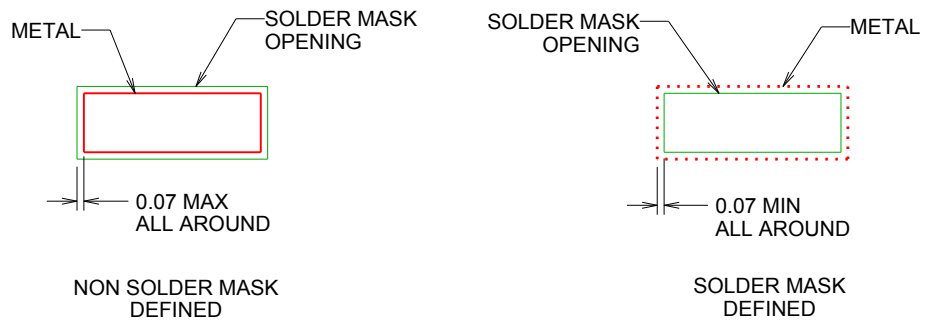

SOLDER MASK DETAILS

4218796/A 09/2013

NOTES: (continued)

- 5. Publication IPC-7351 may have alternate designs.
- 6. Solder mask tolerances between and around signal pads can vary based on board fabrication site.



SOLDER PASTE EXAMPLE  
 BASED ON 0.125 mm THICK STENCIL  
 SCALE:6X

4218796/A 09/2013

NOTES: (continued)

- 7. Laser cutting apertures with trapezoidal walls and rounded corners may offer better paste release. IPC-7525 may have alternate design recommendations.
- 8. Board assembly site may have different recommendations for stencil design.

## GENERIC PACKAGE VIEW

**DW 16**

**SOIC - 2.65 mm max height**

7.5 x 10.3, 1.27 mm pitch

SMALL OUTLINE INTEGRATED CIRCUIT

This image is a representation of the package family, actual package may vary.  
Refer to the product data sheet for package details.



4224780/A





DW0016A

# PACKAGE OUTLINE

SOIC - 2.65 mm max height

SOIC



4220721/A 07/2016

NOTES:

1. All linear dimensions are in millimeters. Dimensions in parenthesis are for reference only. Dimensioning and tolerancing per ASME Y14.5M.
2. This drawing is subject to change without notice.
3. This dimension does not include mold flash, protrusions, or gate burrs. Mold flash, protrusions, or gate burrs shall not exceed 0.15 mm, per side.
4. This dimension does not include interlead flash. Interlead flash shall not exceed 0.25 mm, per side.
5. Reference JEDEC registration MS-013.

# EXAMPLE BOARD LAYOUT

DW0016A

SOIC - 2.65 mm max height

SOIC

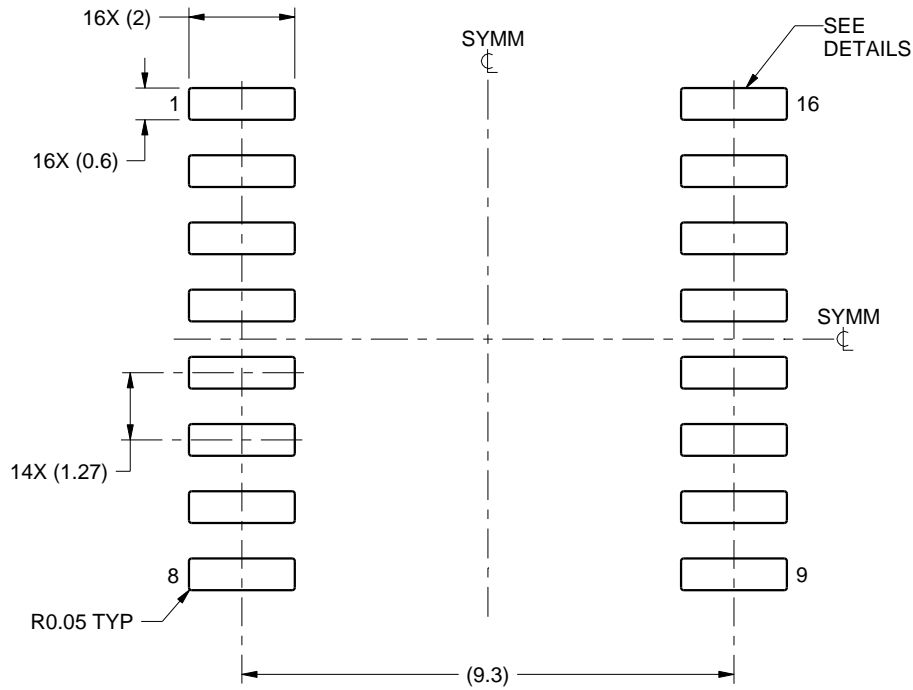

LAND PATTERN EXAMPLE  
SCALE:7X

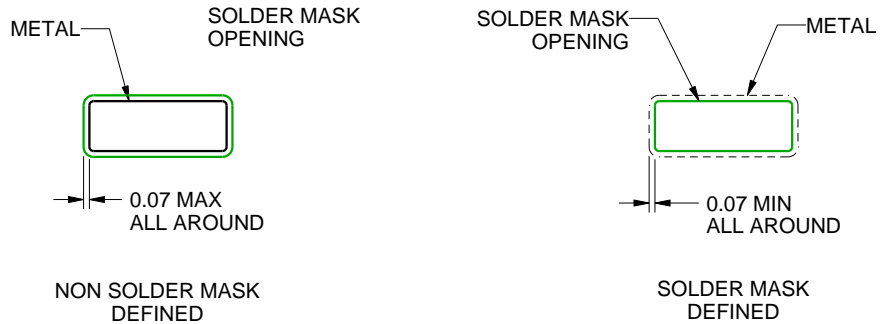

SOLDER MASK DETAILS

4220721/A 07/2016

NOTES: (continued)

- 6. Publication IPC-7351 may have alternate designs.
- 7. Solder mask tolerances between and around signal pads can vary based on board fabrication site.

# EXAMPLE STENCIL DESIGN

DW0016A

SOIC - 2.65 mm max height

SOIC



SOLDER PASTE EXAMPLE  
BASED ON 0.125 mm THICK STENCIL  
SCALE:7X

4220721/A 07/2016

NOTES: (continued)

8. Laser cutting apertures with trapezoidal walls and rounded corners may offer better paste release. IPC-7525 may have alternate design recommendations.
9. Board assembly site may have different recommendations for stencil design.



# DW0016B

# PACKAGE OUTLINE

## SOIC - 2.65 mm max height

SOIC

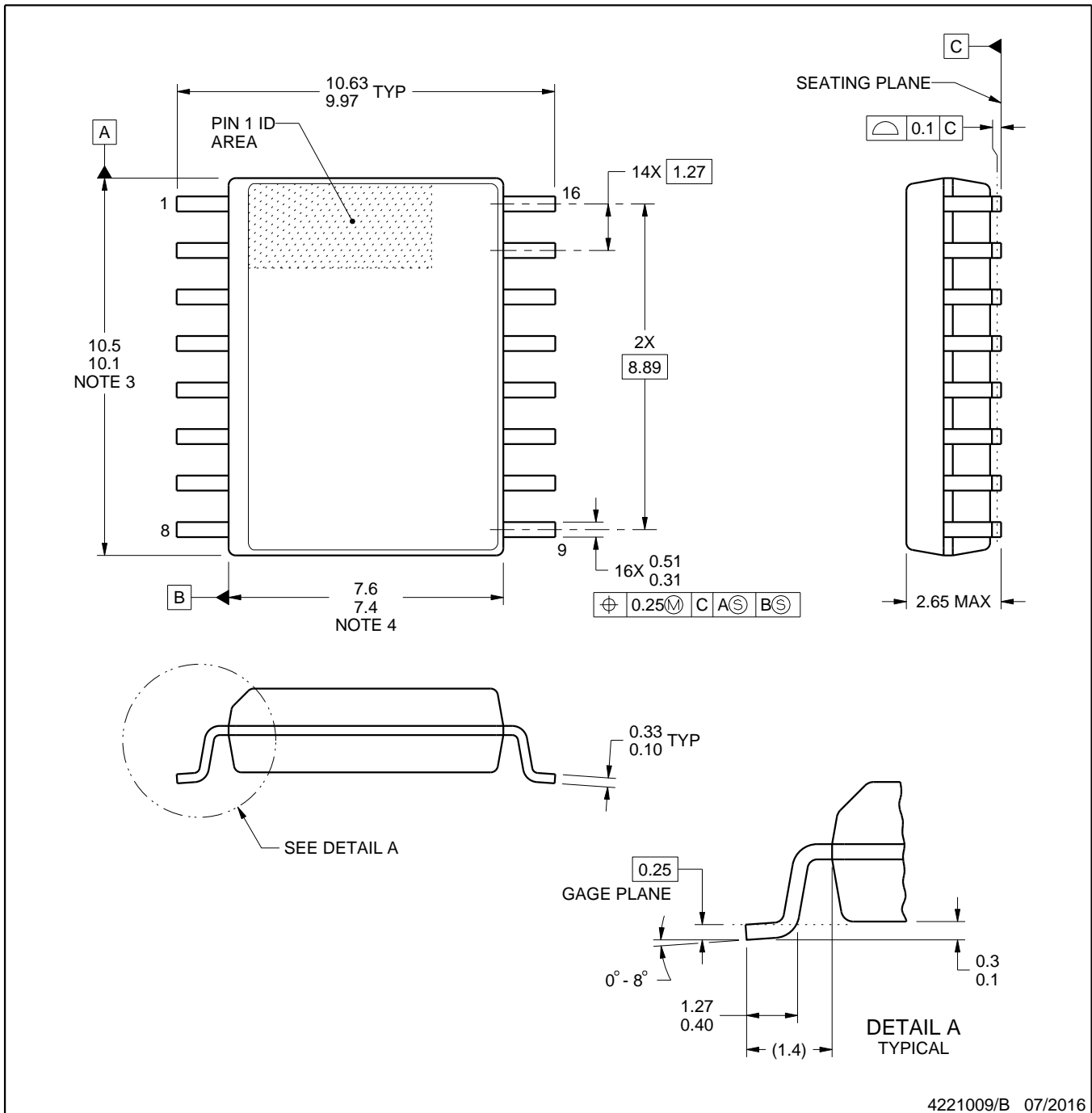

4221009/B 07/2016

### NOTES:

1. All linear dimensions are in millimeters. Dimensions in parenthesis are for reference only. Dimensioning and tolerancing per ASME Y14.5M.
2. This drawing is subject to change without notice.
3. This dimension does not include mold flash, protrusions, or gate burrs. Mold flash, protrusions, or gate burrs shall not exceed 0.15 mm, per side.
4. This dimension does not include interlead flash. Interlead flash shall not exceed 0.25 mm, per side.
5. Reference JEDEC registration MS-013.

# EXAMPLE BOARD LAYOUT

DW0016B

SOIC - 2.65 mm max height

SOIC



LAND PATTERN EXAMPLE  
SCALE:4X



SOLDER MASK DETAILS

4221009/B 07/2016

NOTES: (continued)

- 6. Publication IPC-7351 may have alternate designs.
- 7. Solder mask tolerances between and around signal pads can vary based on board fabrication site.

# EXAMPLE STENCIL DESIGN

DW0016B

SOIC - 2.65 mm max height

SOIC



NOTES: (continued)

8. Laser cutting apertures with trapezoidal walls and rounded corners may offer better paste release. IPC-7525 may have alternate design recommendations.
9. Board assembly site may have different recommendations for stencil design.

## 重要なお知らせと免責事項

TI は、技術データと信頼性データ (データシートを含みます)、設計リソース (リファレンス・デザインを含みます)、アプリケーションや設計に関する各種アドバイス、Web ツール、安全性情報、その他のリソースを、欠陥が存在する可能性のある「現状のまま」提供しており、商品性および特定目的に対する適合性の黙示保証、第三者の知的財産権の非侵害保証を含むいかなる保証も、明示的または黙示的にかかわらず拒否します。

これらのリソースは、TI 製品を使用する設計の経験を積んだ開発者への提供を意図したものです。(1) お客様のアプリケーションに適した TI 製品の選定、(2) お客様のアプリケーションの設計、検証、試験、(3) お客様のアプリケーションに該当する各種規格や、その他のあらゆる安全性、セキュリティ、規制、または他の要件への確実な適合に関する責任を、お客様のみが単独で負うものとし、

上記の各種リソースは、予告なく変更される可能性があります。これらのリソースは、リソースで説明されている TI 製品を使用するアプリケーションの開発の目的でのみ、TI はその使用をお客様に許諾します。これらのリソースに関して、他の目的で複製することや掲載することは禁止されています。TI や第三者の知的財産権のライセンスが付与されている訳ではありません。お客様は、これらのリソースを自身で使用した結果発生するあらゆる申し立て、損害、費用、損失、責任について、TI およびその代理人を完全に補償するものとし、TI は一切の責任を拒否します。

TI の製品は、[TI の販売条件](#)、または [ti.com](#) やかかる TI 製品の関連資料などのいずれかを通じて提供する適用可能な条項の下で提供されています。TI がこれらのリソースを提供することは、適用される TI の保証または他の保証の放棄の拡大や変更を意味するものではありません。

お客様がいかなる追加条項または代替条項を提案した場合でも、TI はそれらに異議を唱え、拒否します。

郵送先住所 : Texas Instruments, Post Office Box 655303, Dallas, Texas 75265  
Copyright © 2024, Texas Instruments Incorporated