

ATL431LI-Q1/ATL432LI-Q1 高帯域幅、低 I_Q のプログラム可能なシャント・レギュレータ

1 特長

- 車載アプリケーション用に認定済み
- 下記内容で AEC-Q100 認定済み
 - デバイス温度グレード 1: 動作時周囲温度 $-40^{\circ}\text{C} \sim +125^{\circ}\text{C}$
- 25°C での基準電圧の許容公差
 - 0.5% (B グレード)
 - 1% (A グレード)
- 出力電圧の最小値: 2.5V (標準値)
- 可変出力電圧: $V_{\text{ref}} \sim 36\text{V}$
- $-40^{\circ}\text{C} \sim +125^{\circ}\text{C}$ で動作
- 最大温度ドリフト: 27mV
- 出カインピーダンス: 0.3Ω (標準値)
- シンク電流能力
 - $I_{\text{min}} = 0.08\text{mA}$ (最大値)
 - $I_{\text{KA}} = 15\text{mA}$ (最大値)
- 基準入力電流 $I_{\text{REF}}: 0.4\mu\text{A}$ (最大値)
- 全温度範囲にわたる基準入力電流の偏差、 $I_{\text{I(dev)}}: 0.3\mu\text{A}$ (最大値)

2 アプリケーション

- インバータおよびモータ制御
- DC/DC コンバータ
- LED ライティング
- オンボード充電器 (OBC)
- インフォテインメント / クラスタ

3 概要

ATL43xLI-Q1 は 3 端子の可変シャント・レギュレータで、該当する車載、商業、軍事用の温度範囲全体にわたって熱的な安定性が規定されています。出力電圧は、2 つの外付け抵抗を使用して、 V_{ref} (約 2.5V) から 36V までの範囲で任意の値に設定できます。このデバイスの出カインピーダンスは 0.3Ω (標準値) です。このデバイスは、アクティブ出力回路による非常に鋭い起動特性を備えているため、オンボード・レギュレーション、可変電源、スイッチング電源などの多くの用途でツェナー・ダイオードの優れた代替品となります。このデバイスは TL431LI-Q1 および TL432LI-Q1 とピン互換の代替品であり、最小動作電流が小さいため、システムの消費電力削減に役立ちます。ATL432LI-Q1 の機能と電氣的仕様は ATL431LI-Q1 と完全に同じですが、DBZ パッケージのピン配置が異なります。

ATL431LI-Q1 は、初期公差 (25°C 時) が 0.5% の B グレードと、1% の A グレードの 2 つのグレードで供給されており、温度に対する出力ドリフトが小さいため、温度範囲全体にわたって優れた安定性が得られます。

製品情報⁽¹⁾

型番	パッケージ(ピン)	本体サイズ(公称)
ATL43xLI	SOT-23 (3)	2.90mm×1.30mm

(1) 提供されているすべてのパッケージについては、巻末の注文情報を参照してください。

概略回路図

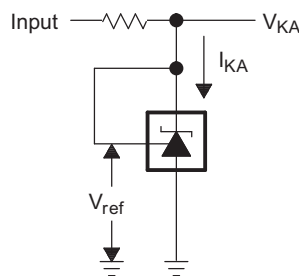

目次

1	特長	1	9.3	Feature Description	13
2	アプリケーション	1	9.4	Device Functional Modes	13
3	概要	1	10	Applications and Implementation	14
4	改訂履歴	2	10.1	Application Information	14
5	Device Comparison Table	3	10.2	Typical Applications	14
6	Pin Configuration and Functions	3	10.3	System Examples	24
7	Specifications	4	11	Power Supply Recommendations	27
7.1	Absolute Maximum Ratings	4	12	Layout	27
7.2	ESD Ratings	4	12.1	Layout Guidelines	27
7.3	Recommended Operating Conditions	4	12.2	Layout Example	27
7.4	Thermal Information	4	13	デバイスおよびドキュメントのサポート	28
7.5	Electrical Characteristics	5	13.1	デバイス・サポート	28
7.6	Typical Characteristics	6	13.2	ドキュメントのサポート	28
8	Parameter Measurement Information	9	13.3	関連リンク	28
8.1	Temperature Coefficient	9	13.4	ドキュメントの更新通知を受け取る方法	28
8.2	Dynamic Impedance	10	13.5	サポート・リソース	28
9	Detailed Description	11	13.6	商標	28
9.1	Overview	11	13.7	静電気放電に関する注意事項	29
9.2	Functional Block Diagram	11	13.8	Glossary	29
			14	メカニカル、パッケージ、および注文情報	29

4 改訂履歴

資料番号末尾の英字は改訂を表しています。その改訂履歴は英語版に準じています。

2019年5月発行のものから更新

Page

•	デバイスのステータスを「事前情報」から「量産データ」に変更	1
---	-------------------------------	---

5 Device Comparison Table

DEVICE PINOUT	INITIAL ACCURACY	OPERATING FREE-AIR TEMPERATURE (T _A)
ATL431LI-Q1 ATL432LI-Q1	A: 1% B: 0.5%	Q: -40°C to 125°C

6 Pin Configuration and Functions

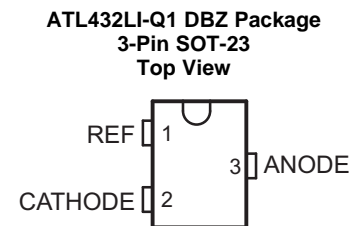
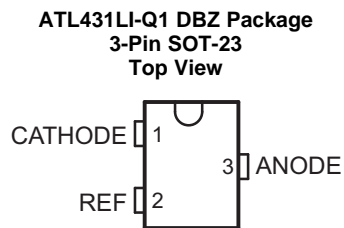

Pin Functions

NAME	PIN		TYPE	DESCRIPTION
	ATL431LI-Q1	ATL432LI-Q1		
	DBZ	DBZ		
ANODE	3	3	O	Common pin, normally connected to ground
CATHODE	1	2	I/O	Shunt Current/Voltage input
REF	2	1	I	Threshold relative to common anode

7 Specifications

7.1 Absolute Maximum Ratings

over operating free-air temperature range (unless otherwise noted)⁽¹⁾

		MIN	MAX	UNIT
V _{KA}	Cathode Voltage ⁽²⁾		37	V
I _{KA}	Continuous Cathode Current Range	-10	18	mA
I _{I(ref)}	Reference Input Current	-5	10	mA
T _J	Operating Junction Temperature Range	-40	150	C
T _{stg}	Storage Temperature Range	-65	150	C

- (1) Stresses beyond those listed under *Absolute Maximum Ratings* may cause permanent damage to the device. These are stress ratings only, which do not imply functional operation of the device at these or any other conditions beyond those indicated under *Recommended Operating Conditions*. Exposure to absolute-maximum-rated conditions for extended periods may affect device reliability.
- (2) All voltage values are with respect to ANODE, unless otherwise noted.

7.2 ESD Ratings

		VALUE	UNIT
V _(ESD)	Electrostatic discharge	Human body model (HBM), per AEC Q100-002 ⁽¹⁾	±4000
		Charged-device model (CDM), per AEC Q100-011	±1000

- (1) AEC Q100-002 indicates that HBM stressing shall be in accordance with the ANSI/ESDA/JEDEC JS-001 specification

7.3 Recommended Operating Conditions

		MIN	MAX	UNIT
V _{KA}	Cathode Voltage	V _{REF}	36	V
I _{KA}	Continuous Cathode Current Range	0.08	15	mA
T _A	Operating Free-Air Temperature ⁽¹⁾			
				ATL43xLIxQ
		-40	125	C

- (1) Maximum power dissipation is a function of T_{J(max)}, θ_{JA}, and T_A. The maximum allowable power dissipation at any allowable ambient temperature is P_D = (T_{J(max)} - T_A)/θ_{JA}. Operating at the absolute maximum T_J can affect reliability. See the [Semiconductor and IC Package Thermal Metrics Application Report](#) for more information.

7.4 Thermal Information

THERMAL METRIC ⁽¹⁾		ATL43xLI	UNIT
		DBZ	
		3 PINS	
R _{θJA}	Junction-to-ambient thermal resistance	371.7	C/W
R _{θJC(top)}	Junction-to-case (top) thermal resistance	145.9	C/W
R _{θJB}	Junction-to-board thermal resistance	104.7	C/W
ψ _{JT}	Junction-to-top characterization parameter	23.9	C/W
ψ _{JB}	Junction-to-board characterization parameter	102.9	C/W

- (1) For more information about traditional and new thermal metrics, see the [Semiconductor and IC Package Thermal Metrics Application Report](#).

7.5 Electrical Characteristics

over recommended operating conditions, $T_A = 25^\circ\text{C}$ (unless otherwise noted)

PARAMETER	TEST CIRCUIT	TEST CONDITIONS	MIN	TYP	MAX	UNIT		
V_{REF}	Reference Voltage	See 17	$V_{\text{KA}} = V_{\text{ref}}, I_{\text{KA}} = 1 \text{ mA}$	ATL43xLIAx devices	2475	2500	2525	mV
				ATL43xLIBx devices	2487	2500	2512	mV
$V_{\text{I(dev)}}$	Deviation of reference input voltage over full temperature range ⁽¹⁾	See 17		10	27	mV		
$\frac{\Delta V_{\text{ref}}}{\Delta V_{\text{KA}}}$	Ratio of change in reference voltage to the change in cathode voltage	See 18	$I_{\text{KA}} = 1 \text{ mA}$	$\Delta V_{\text{KA}} = 10 \text{ V} - V_{\text{ref}}$	-1.4	-2.7	mV/V	
				$\Delta V_{\text{KA}} = 36 \text{ V} - 10 \text{ V}$	-1	-2	mV/V	
I_{ref}	Reference Input Current	See 18		0.2	0.4	μA		
$I_{\text{I(dev)}}$	Deviation of reference input current over full temperature range ⁽¹⁾	See 18		0.1	0.3	μA		
I_{min}	Minimum cathode current for regulation	See 17		65	80	μA		
I_{off}	Off-state cathode current	See 19		0.1	1	μA		
$ Z_{\text{KA}} $	Dynamic Impedance ⁽²⁾	See 17		0.65	0.75	Ω		

- (1) The deviation parameters $V_{\text{I(dev)}}$ and $I_{\text{I(dev)}}$ are defined as the differences between the maximum and minimum values obtained over the rated temperature range. For more details on $V_{\text{I(dev)}}$ and how it relates to the average temperature coefficient, see the [Temperature Coefficient](#) section.
- (2) The dynamic impedance is defined by $|Z_{\text{KA}}| = \Delta V_{\text{KA}} / \Delta I_{\text{KA}}$. For more details on $|Z_{\text{KA}}|$ and how it relates to V_{out} , see the [Temperature Coefficient](#) section.

7.6 Typical Characteristics

Data at high and low temperatures are applicable only within the recommended operating free-air temperature ranges of the various devices.

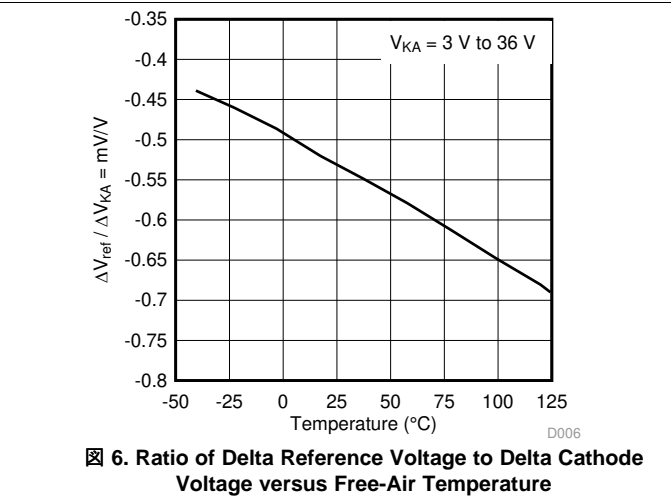
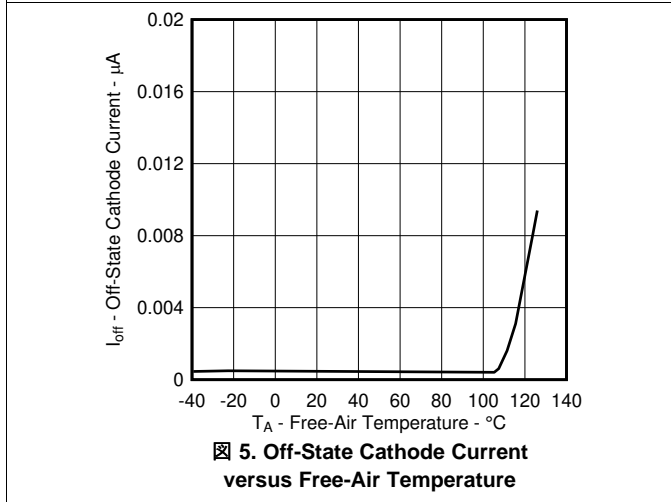
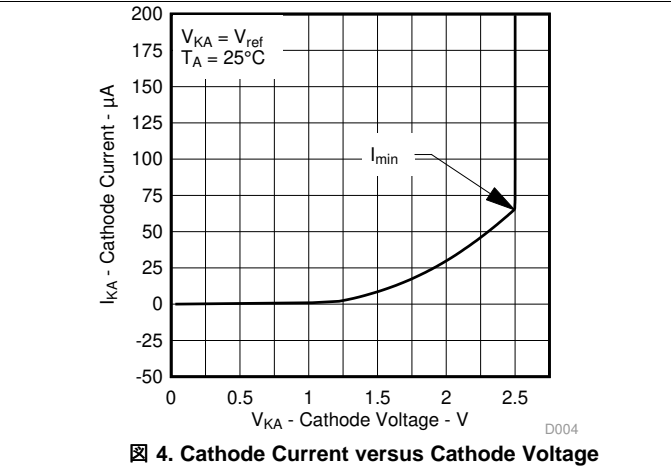
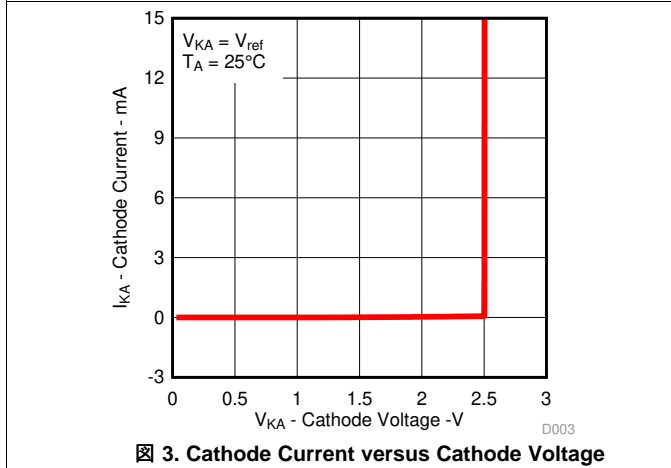
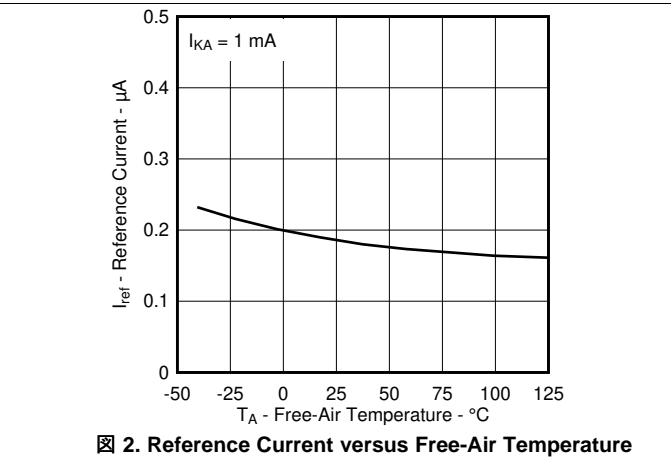
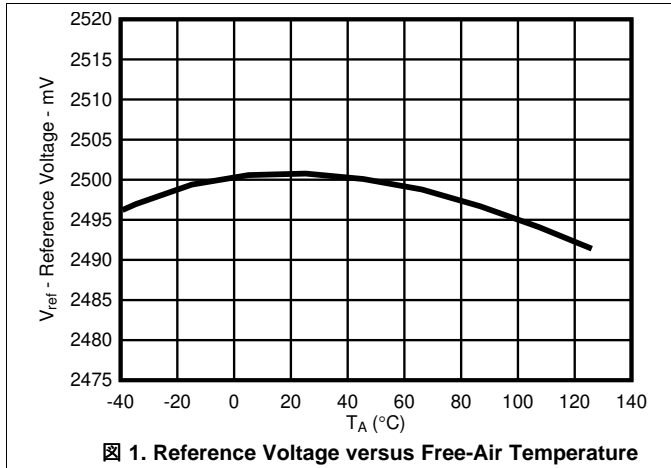

Typical Characteristics (continued)

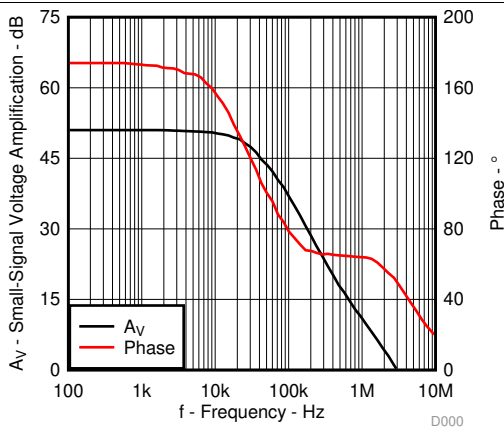

Fig. 7. Small-Signal Voltage Amplification versus Frequency

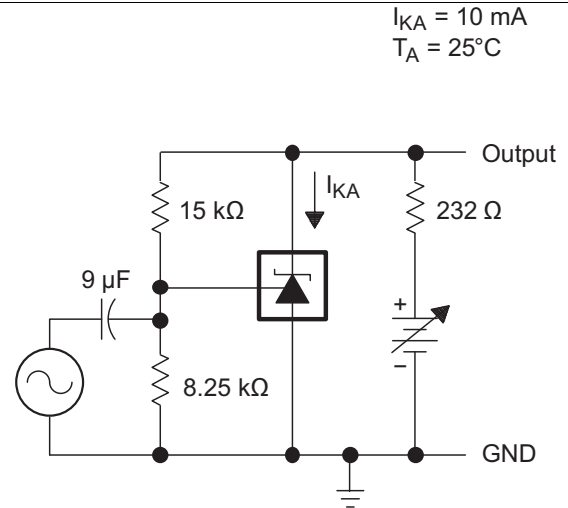

Fig. 8. Test Circuit for Voltage Amplification

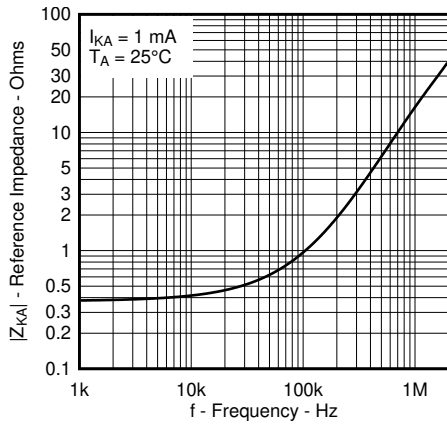

Fig. 9. Reference Impedance versus Frequency

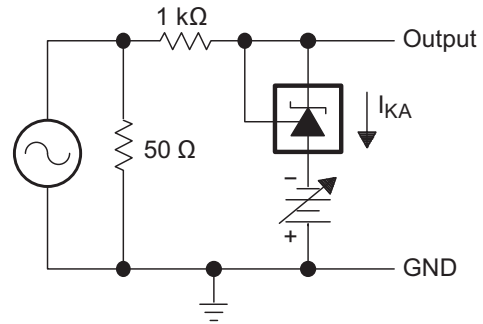

Fig. 10. Test Circuit for Reference Impedance

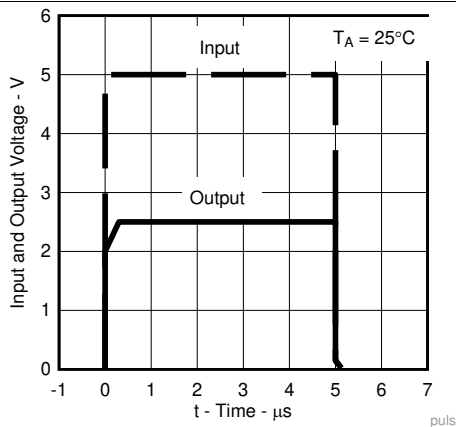

Fig. 11. Pulse Response

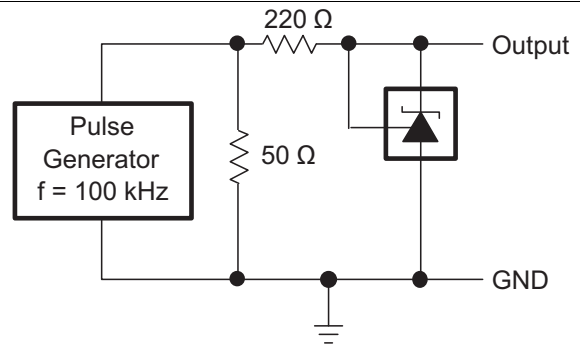
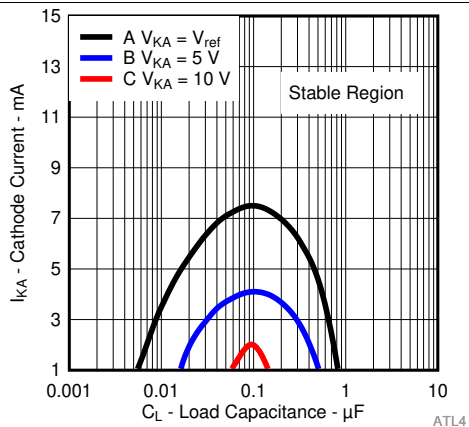

Fig. 12. Test Circuit for Pulse Response

Typical Characteristics (continued)



The areas under the curves represent conditions that may cause the device to oscillate. For curves B and C, R2 and V+ are adjusted to establish the initial V_{KA} and I_{KA} conditions, with $C_L = 0$. V_{BATT} and C_L then are adjusted to determine the ranges of stability.

13. Stability Boundary Conditions for All ATL431LI-Q1, ATL432LI-Q1 Devices Above 1 mA

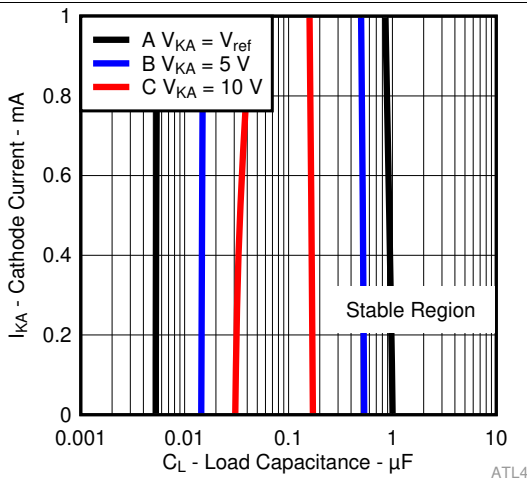

The areas in-between the curves represent conditions that may cause the device to oscillate. For curves B and C, R2 and V+ are adjusted to establish the initial V_{KA} and I_{KA} conditions, with $C_L = 0$. V_{BATT} and C_L then are adjusted to determine the ranges of stability.

15. Stability Boundary Conditions for All ATL431LI-Q1, ATL432LI-Q1 Devices Below 1 mA

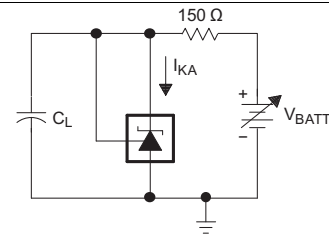

TEST CIRCUIT FOR CURVE A

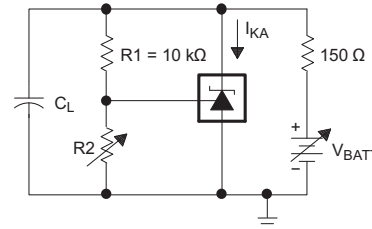

TEST CIRCUIT FOR CURVES B, C, AND D

14. Test Circuit for Stability Boundary Conditions

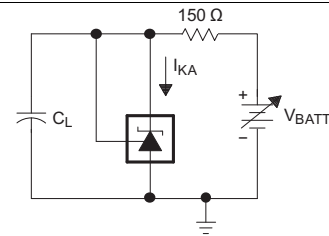

TEST CIRCUIT FOR CURVE A

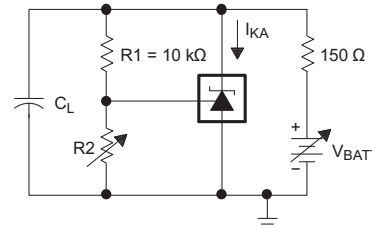

TEST CIRCUIT FOR CURVES B, C, AND D

16. Test Circuit for Stability Boundary Conditions

8 Parameter Measurement Information

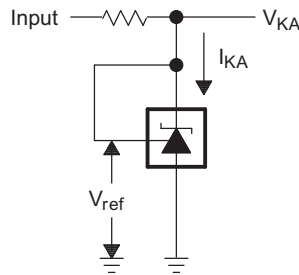

Figure 17. Test Circuit for $V_{KA} = V_{ref}$

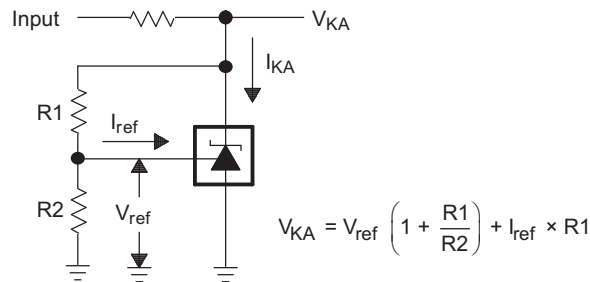

Figure 18. Test Circuit for $V_{KA} > V_{ref}$

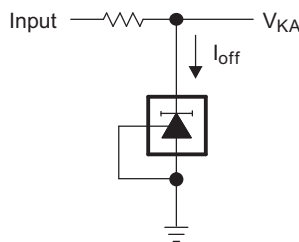

Figure 19. Test Circuit for I_{off}

8.1 Temperature Coefficient

The deviation of the reference voltage, V_{ref} , over the full temperature range is known as $V_{I(dev)}$. The parameter of $V_{I(dev)}$ can be used to find the temperature coefficient of the device. The average full-range temperature coefficient of the reference input voltage, $\alpha_{V_{ref}}$, is defined as:

$$\left| \alpha_{V_{ref}} \right| \left(\frac{\text{ppm}}{\text{°C}} \right) = \frac{\left(\frac{V_{I(dev)}}{V_{ref \text{ at } 25 \text{ °C}}} \right) \times 10^6}{\Delta T_A}$$

where:

ΔT_A is the rated operating temperature range of the device.

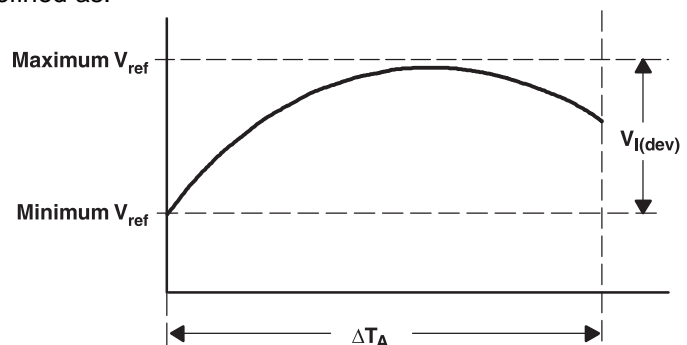

$\alpha_{V_{ref}}$ is positive or negative, depending on whether minimum V_{ref} or maximum V_{ref} , respectively, occurs at the lower temperature. The full-range temperature coefficient is an average and, therefore, any subsection of the rated operating temperature range can yield a value that is greater or less than the average. For more details on temperature coefficient, refer to the [Voltage Reference Selection Basics White Paper](#).

8.2 Dynamic Impedance

The dynamic impedance is defined as: $|Z_{KA}| = \frac{\Delta V_{KA}}{\Delta I_{KA}}$. When the device is operating with two external resistors (see [Figure 18](#)), the total dynamic impedance of the circuit is given by: $|z'| = \frac{\Delta V}{\Delta I}$, which is approximately equal to $|Z_{KA}| \left(1 + \frac{R1}{R2}\right)$.

The V_{KA} of the ATL431LI-Q1 can be affected by the dynamic impedance. The ATL431LI-Q1 test current I_{test} for V_{KA} is specified in the [Electrical Characteristics](#). Any deviation from I_{test} can cause deviation on the output V_{KA} . [Figure 20](#) shows the effect of the dynamic impedance on the V_{KA} .

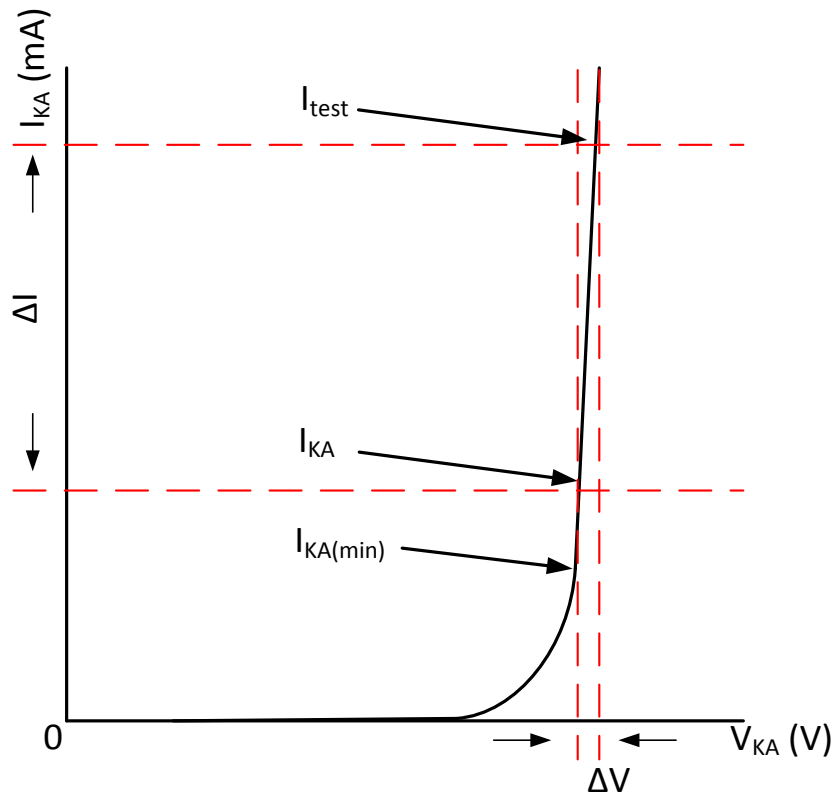

Figure 20. Dynamic Impedance

9 Detailed Description

9.1 Overview

This standard device has proven ubiquity and versatility across a wide range of applications, ranging from power to signal path. This is due to its key components containing an accurate voltage reference and op amp, which are very fundamental analog building blocks. The ATL431LI-Q1 is used in conjunction with the key components to behave as the following:

- Single voltage reference
- Error amplifier
- Voltage clamp
- Comparator with integrated reference

ATL431LI-Q1 can be operated and adjusted to cathode voltages from 2.5 V to 36 V, making this part optimal for a wide range of end equipments in industrial, auto, telecom, and computing. For this device to behave as a shunt regulator or error amplifier, $>80 \mu\text{A}$ (I_{min} (maximum)) must be supplied in to the cathode pin. Under this condition, feedback can be applied from the Cathode and Ref pins to create a replica of the internal reference voltage.

Various reference voltage options can be purchased with initial tolerances (at 25°C) of 0.5% and 1%. These reference options are denoted by B (0.5%) and A (1.0%) after the ATL431LI-Q1 or ATL432LI-Q1. ATL431LI-Q1 and ATL432LI-Q1 are both functionally the same, but have different pinout options. The ATL43xLI-Q1 devices are characterized for operation from -40°C to $+125^{\circ}\text{C}$.

9.2 Functional Block Diagram

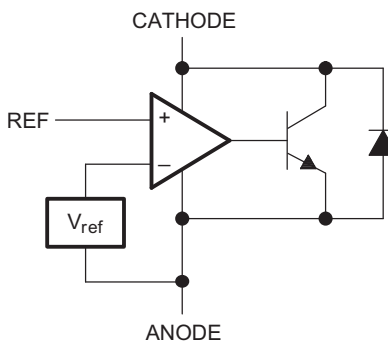

☒ 21. Equivalent Schematic

Functional Block Diagram (continued)

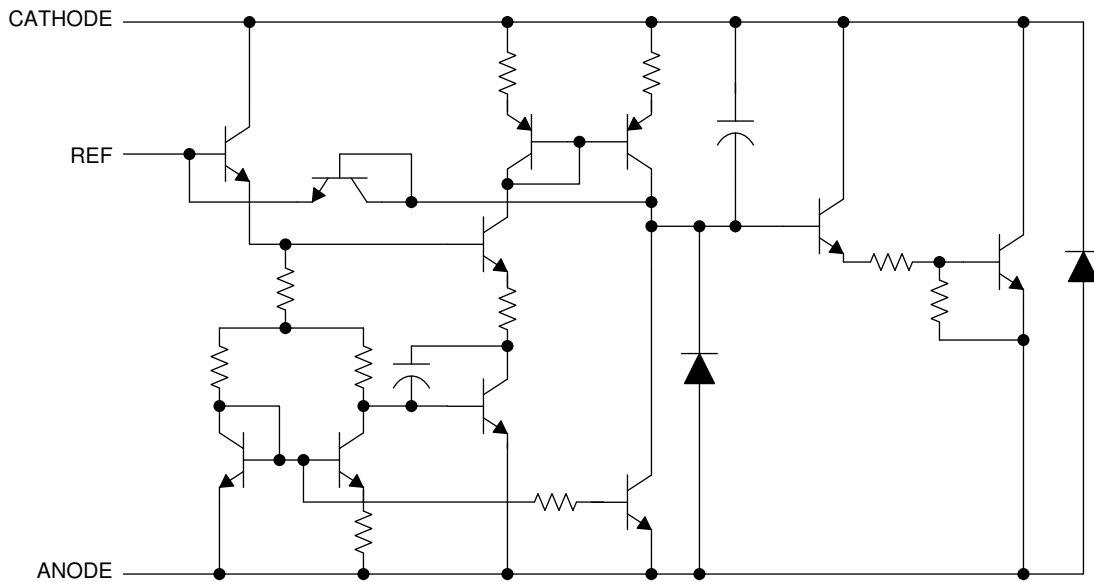

⊗ 22. Detailed Schematic

9.3 Feature Description

The ATL431LI-Q1 consists of an internal reference and amplifier that outputs a sink current based on the difference between the reference pin and the virtual internal pin. The sink current is produced by the internal Darlington pair, shown in [Figure 21](#). A Darlington pair is used for this device to be able to sink a maximum current of 15 mA.

When operated with enough voltage headroom (≥ 2.5 V) and cathode current (I_{KA}), the ATL431LI-Q1 forces the reference pin to 2.5 V. However, the reference pin cannot be left floating, as it needs $I_{REF} \geq 0.4$ μ A (see the [Specifications](#)). This is because the reference pin is driven into an NPN, which needs base current to operate properly.

When feedback is applied from the Cathode and Reference pins, the ATL431LI-Q1 behaves as a Zener diode, regulating to a constant voltage dependent on current being supplied into the cathode. This is due to the internal amplifier and reference entering the proper operating regions. The same amount of current needed in the above feedback situation must be applied to this device in open loop, servo, or error amplifying implementations for it to be in the proper linear region giving ATL431LI-Q1 enough gain.

Unlike many linear regulators, ATL431LI-Q1 is internally compensated to be stable without an output capacitor between the cathode and anode. However, if it is desired to use an output capacitor [Figure 13](#) can be used as a guide to assist in choosing the correct capacitor to maintain stability.

9.4 Device Functional Modes

9.4.1 Open Loop (Comparator)

When the cathode/output voltage or current of ATL431LI-Q1 is not being fed back to the reference/input pin in any form, this device is operating in open loop. With proper cathode current (I_{KA}) applied to this device, the ATL431LI-Q1 has the characteristics shown in [Figure 21](#). With such high gain in this configuration, the ATL431LI-Q1 is typically used as a comparator. With the reference integrated makes ATL431LI-Q1 the preferred choice when users are trying to monitor a certain level of a single signal.

9.4.2 Closed Loop

When the cathode/output voltage or current of the ATL431LI-Q1 is being fed back to the reference/input pin in any form, this device is operating in closed loop. The majority of applications involving ATL431LI-Q1 use it in this manner to regulate a fixed voltage or current. The feedback enables this device to behave as an error amplifier, computing a portion of the output voltage and adjusting it to maintain the desired regulation. This is done by relating the output voltage back to the reference pin in a manner to make it equal to the internal reference voltage, which can be accomplished via resistive or direct feedback.

10 Applications and Implementation

注

Information in the following applications sections is not part of the TI component specification, and TI does not warrant its accuracy or completeness. TI's customers are responsible for determining suitability of components for their purposes. Customers should validate and test their design implementation to confirm system functionality.

10.1 Application Information

As this device has many applications and setups, there are many situations that this data sheet cannot characterize in detail. The linked application note will help the designer make the best choices when using this part.

[Setting the Shunt Voltage on an Adjustable Shunt Regulator Application Note](#) assists with setting the shunt voltage to achieve optimum accuracy for this device.

10.2 Typical Applications

10.2.1 Comparator With Integrated Reference

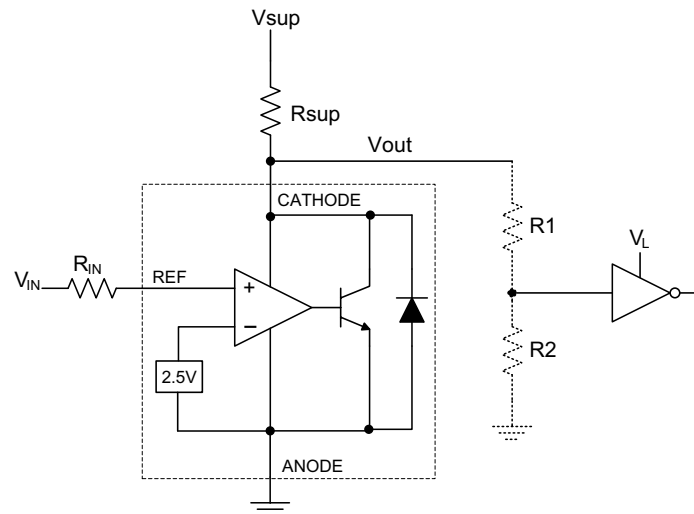

☒ 23. Comparator Application Schematic

Typical Applications (continued)

10.2.2 Design Requirements

For this design example, use the parameters listed in [表 1](#) as the input parameters.

表 1. Design Parameters

DESIGN PARAMETER	EXAMPLE VALUE
Input Voltage Range	0 V to 5 V
Input Resistance	10 kΩ
Supply Voltage	24 V
Cathode Current (I _k)	5 mA
Output Voltage Level	~2 V – V _{SUP}
Logic Input Thresholds VIH/VIL	V _L

10.2.3 Detailed Design Procedure

When using the ATL431LI-Q1 as a comparator with reference, determine the following:

- Input voltage range
- Reference voltage accuracy
- Output logic input high and low level thresholds
- Current source resistance

10.2.3.1 Basic Operation

In the configuration shown in [图 23](#), the ATL431LI-Q1 behaves as a comparator, comparing the V_{REF} pin voltage to the internal virtual reference voltage. When provided a proper cathode current (I_k), ATL431LI-Q1 has enough open-loop gain to provide a quick response. This can be seen in [图 24](#) where the R_{SUP} = 10 kΩ (I_{KA} = 500 μA) situation responds much slower than R_{SUP} = 1 kΩ (I_{KA} = 5 mA). With the ATL431LI-Q1 max operating current (I_{MIN}) being 1 mA, operation below that can result in low gain, leading to a slow response.

10.2.3.1.1 Overdrive

Slow or inaccurate responses can also occur when the reference pin is not provided enough overdrive voltage. This is the amount of voltage that is higher than the internal virtual reference. The internal virtual reference voltage is within the range of 2.5 V ±(0.5% or 1.0%) depending on which version is being used. The more overdrive voltage provided, the faster the ATL431LI-Q1 will respond.

For applications where ATL431LI-Q1 is being used as a comparator, it is best to set the trip point to greater than the positive expected error (that is +1.0% for the A version). For fast response, setting the trip point to >10% of the internal V_{REF} suffices.

For minimal voltage drop or difference from Vin to the ref pin, TI recommends to use an input resistor <10 kΩ to provide I_{ref}.

10.2.3.2 Output Voltage and Logic Input Level

For ATL431LI-Q1 to properly be used as a comparator, the logic output must be readable by the receiving logic device. This is accomplished by knowing the input high and low level threshold voltage levels, typically denoted by V_{IH} and V_{IL} .

As seen in [Figure 24](#), the output low level voltage of the ATL431LI-Q1 in open-loop/comparator mode is approximately 2 V, which is typically sufficient for 5 V supplied logic. However, this does not work for 3.3 V and 1.8 V supplied logic. To accommodate this, a resistive divider can be tied to the output to attenuate the output voltage to a voltage legible to the receiving low voltage logic device.

The output high voltage of the ATL431 is equal to V_{SUP} due to ATL431LI-Q1 being open-collector. If V_{SUP} is much higher than the maximum input voltage tolerance of the receiving logic, the output must be attenuated to accommodate the reliability of the outgoing logic.

When using a resistive divider on the output, make sure the sum of the resistive divider (R_1 and R_2 in [Figure 23](#)) is much greater than R_{SUP} to not interfere with the ability of the ATL431LI-Q1 to pull close to V_{SUP} when turning off.

10.2.3.2.1 Input Resistance

The ATL431LI-Q1 requires an input resistance in this application to source the reference current (I_{REF}) needed from this device to be in the proper operating regions while turning on. The actual voltage seen at the ref pin is $V_{REF} = V_{IN} - I_{REF} \times R_{IN}$ because I_{REF} can be as high as 4 μ A. TI recommends to use a resistance small enough that mitigates the error that I_{REF} creates from V_{IN} .

10.2.4 Application Curves

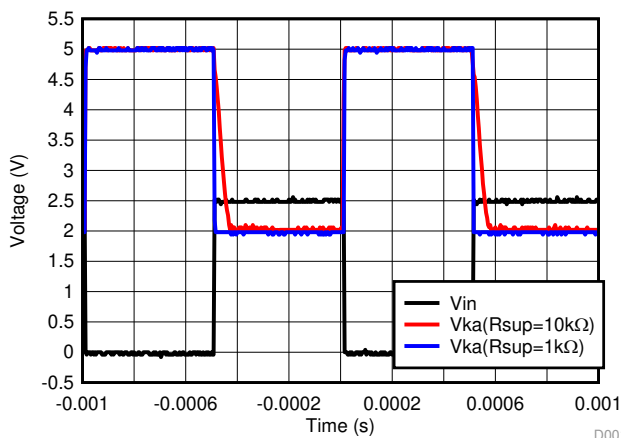

Figure 24. Output Response With Various Cathode Currents

10.2.5 Precision LED Lighting Current Sink Regulator



图 25. LED Lighting Current Sink Regulator

10.2.5.1 Design Requirements

For this design example, use the parameters listed in 表 1 as the input parameters.

表 2. Design Parameters

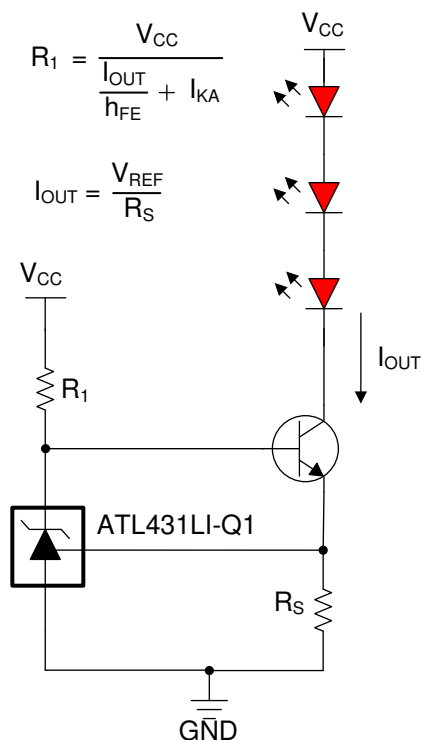
DESIGN PARAMETER	EXAMPLE VALUE
Supply Voltage ($V_{(BATT)}$)	5 V
Sink Current (I_O)	100 mA
Cathode Current (I_k)	5 mA

10.2.5.2 Detailed Design Procedure

When using the ATL43xLI-Q1 as a constant current sink, determine the following:

- Output current range
- Output current accuracy
- Power consumption for the ATL43xLI-Q1

10.2.5.2.1 Basic Operation

In the configuration shown, the ATL43xLI-Q1 acts as a control component within a feedback loop of the constant current sink. Working with an external passing component such as a BJT, the ATL43xLI-Q1 provides precision current sink with accuracy set by itself and the sense resistor R_S . The LEDs are lit based on the desired current sink and regulated for accurate brightness and color.

10.2.5.2.1.1 Output Current Range and Accuracy

The output current range of the circuit is determined by the equation shown in the configuration. Keep in mind that the V_{REF} equals to 2.500 V. When choosing the sense resistor R_S , it needs to generate 2.500 V for the TL43xLI-Q1 when I_O reaches the target current. If the overhead voltage of 2.500 V is not acceptable, consider lower voltage reference devices such as the TLV43x-Q1 or TLVH43x-Q1.

The output current accuracy is determined by both the accuracy of the ATL43xLI-Q1 chosen, as well as the accuracy of the sense resistor R_S . The internal virtual reference voltage of ATL43xLI-Q1 is within the range of $2.500\text{ V} \pm(0.5\% \text{ or } 1.0\%)$, depending on which version is being used. Another consideration for the output current accuracy is the temperature coefficient of the ATL43xLI-Q1 and R_S . Refer to the for the specification of these parameters.

10.2.5.2.2 Power Consumption

For the ATL43xLI-Q1 to properly be used as a control component in this circuit, the minimum operating current needs to be reached. This is accomplished by setting the external biasing resistor in series with the ATL43xLI-Q1.

To achieve lower power consumption, the ATL43xLI-Q1 is used due to its $65\ \mu\text{A}$ typical minimum cathode current, I_{\min} .

10.2.6 Shunt Regulator/Reference



图 26. Shunt Regulator Schematic

10.2.6.1 Design Requirements

For this design example, use the parameters listed in 表 1 as the input parameters.

表 3. Design Parameters

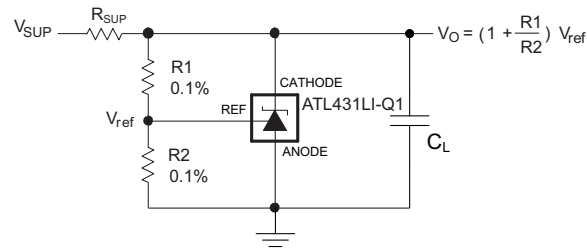
DESIGN PARAMETER	EXAMPLE VALUE
Reference Initial Accuracy	1.0%
Supply Voltage	24 V
Cathode Current (I _k)	5 mA
Output Voltage Level	2.5 V–36 V
Load Capacitance	2 μF
Feedback Resistor Values and Accuracy (R1 and R2)	10 kΩ

10.2.6.2 Detailed Design Procedure

When using ATL431LI-Q1 as a shunt regulator, determine the following:

- Input voltage range
- Temperature range
- Total accuracy
- Cathode current
- Reference initial accuracy
- Output capacitance

10.2.6.2.1 Programming Output/Cathode Voltage

To program the cathode voltage to a regulated voltage, a resistive bridge must be shunted between the cathode and anode pins with the mid point tied to the reference pin. This can be seen in 图 26 with R1 and R2 being the resistive bridge. The cathode/output voltage in the shunt regulator configuration can be approximated by the equation shown in 图 26. The cathode voltage can be more accurate, which can be determined by taking in to account the cathode current:

$$V_o = (1 + R1/R2) \times V_{REF} - I_{REF} \times R1 \quad (1)$$

For this equation to be valid, the ATL431LI-Q1 must be fully biased so that it has enough open loop gain to mitigate any gain error. This can be done by meeting the I_{min} spec denoted in the [Specifications](#).

10.2.6.2.2 Total Accuracy

When programming the output above unity gain ($V_{KA} = V_{REF}$), the ATL431LI-Q1 is susceptible to other errors that can effect the overall accuracy beyond V_{REF} . These errors include:

- R1 and R2 accuracies
- $V_{I(dev)}$: Change in reference voltage over temperature
- $\Delta V_{REF} / \Delta V_{KA}$: Change in reference voltage to the change in cathode voltage
- $|z_{KA}|$: Dynamic impedance, causing a change in cathode voltage with cathode current

Worst case cathode voltage can be determined taking all of the variables in to account. The [Setting the Shunt Voltage on an Adjustable Shunt Regulator Application Note](#) assists designers in setting the shunt voltage to achieve optimum accuracy for this device.

10.2.6.2.3 Stability

Though ATL431LI-Q1 is stable with no capacitive load, the device that receives the output voltage of the shunt regulator can present a capacitive load that is within the ATL431LI-Q1 region of stability, shown in [Figure 13](#). Also, designers can use capacitive loads to improve the transient response or for power supply decoupling. When using additional capacitance between Cathode and Anode, see [Figure 13](#). Also, [Understanding Stability Boundary Conditions Charts in TL431, TL432 Data Sheet Application Note](#) provides a deeper understanding of the stability characteristics of this device and aids the user in making the right choices when choosing a load capacitor.

10.2.6.2.4 Start-Up Time

As shown in [Figure 27](#), the ATL431LI-Q1 has a fast response up to approximately 2 V and then slowly charges to its programmed value. This is due to the compensation capacitance (shown in [Figure 13](#)) the ATL43xLI-Q1 has to meet its stability criteria. Despite the secondary delay, ATL43xLI-Q1 still has a fast response suitable for many clamp applications.

10.2.6.3 Application Curves

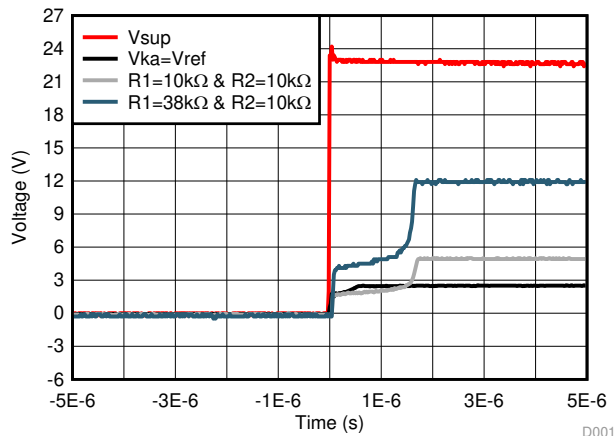

Figure 27. ATL43xLI-Q1 Start-Up Response

10.2.7 Isolated Flyback with Optocoupler



图 28. Isolated Flyback with Optocoupler

10.2.7.1 Design Requirements

The ATL431LI-Q1 is used in the feedback network on the secondary side for a isolated flyback with optocoupler design. 图 28 shows the simplified flyback converter that used the ATL431LI-Q1. For this design example, use the parameters in 表 4 as the input parameters.

表 4. Design Parameters

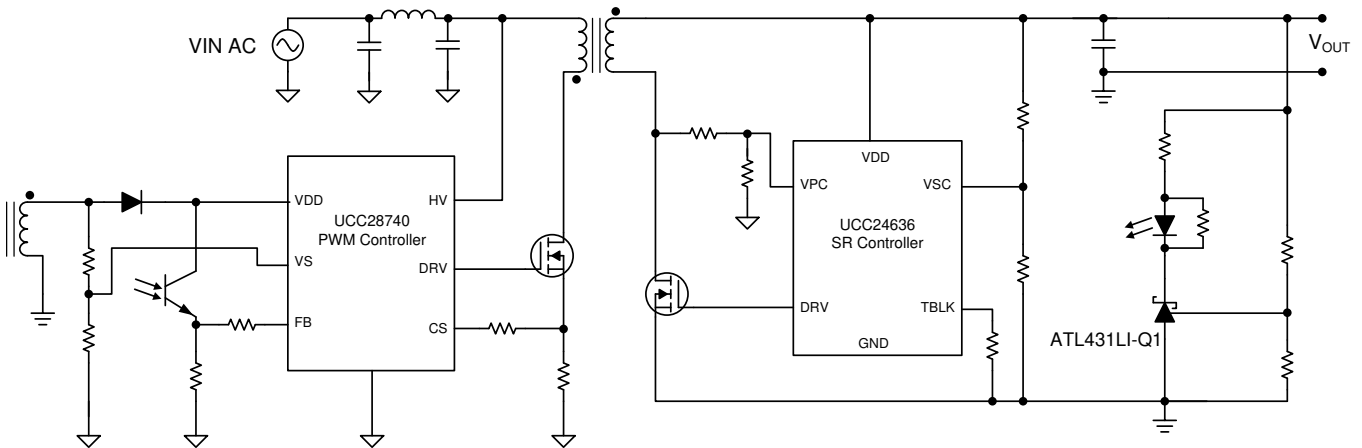
DESIGN PARAMETER	EXAMPLE VALUE
Voltage Output	20 V
Feedback Network Quiescent Current (I_q)	<40 mW

10.2.7.1.1 Detailed Design Procedure

In this example, a simplified design procedure will be discussed. The compensation network for the feedback network is beyond the scope of this section. Details on compensation network can be found in [Compensation Design with TL431 for UCC28600 Application Report](#).

The goal of this design is to design a low standby current feedback network to meet the Europe CoC Tier 2 and United States DoE Level VI requirements. To meet the design requirements, the system standby power needs to be below 75 mW. To meet this, the feedback network needs to consume less than 40 mW to allow margin for the power losses on the primary side controller and passive components. This can pose a challenge in systems greater than 10 V.

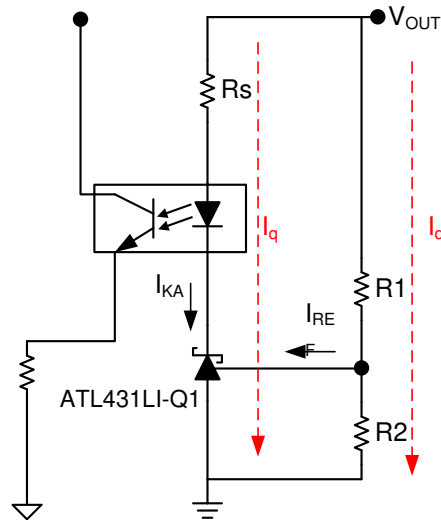

Figure 29. Feedback Quiescent Current

10.2.7.1.1.1 ATL431LI-Q1 Biasing

Figure 29 shows the simplified version of the feedback network. The standby I_q of the system is dependent on two paths: the ATL431LI-Q1 biasing path and the resistor feedback path. With the given design requirements, the total current through the feedback network cannot exceed 2 mA.

The design goal is to take full advantage of the I_{min} to set the I_{KA} of the ATL431LI-Q1. The benefit of the ATL431LI-Q1 is its low I_{min} of 80 μA which allows the I_{KA} to be lower at a full load condition compared to typical TL431LI-Q1 devices. This helps lower the I_{KA} at the no-load condition which is higher than the full load condition due to the dynamic changes in the I_{KA} as the system load varies. The I_{KA} at no-load, I_{OPTNL} , is dependent the value of R_s which is the biasing resistor. R_s is very application-specific and is dependent on variables such as the CTR of the optocoupler, voltage, and current at no-load. This can be seen in Equation 2. It is possible to lower I_{OPTNL} to a value of 1.5 mA for a power loss of 30 mW by using an optocoupler with a high CTR.

$$R_s \approx (V_{OUT} - V_{OPTNL} - 2V) / I_{OPTNL}$$

$$V_{OPTNL} = \text{Optocoupler Voltage at No - Load Conditions}$$

$$I_{OPTNL} = \text{Optocoupler Current at No - Load Conditions}$$

(2)

10.2.7.1.1.2 Resistor Feedback Network

The feedback resistors set the output voltage of the secondary side and consume the same I_q at a fixed voltage. The design goal for the feedback resistor path is to minimize the resistor error while maintaining a low I_q . For this system example, the feedback network path in this design consumes 0.5 mA to allow enough current for ATL431LI-Q1 biasing. The resistors, R_1 and R_2 , are sized based on a 0.5 mA budget for I_q and I_{ref} . By using the resistor values from Equation 3 and Equation 4, the total power consumption is 10 mW. This can be further decreased by using larger resistors.

$$R_1 = (V_{OUT} - V_{REF}) / I_{FB}$$

$$R_1 = (20V - 2.5V) / 0.5mA$$

$$R_1 = 35k\Omega$$

(3)

$$R_2 = V_{REF} / (I_{FB} - I_{REF})$$

$$R_2 = 2.5V / (0.5mA - 0.4\mu A)$$

$$R_2 = 5.004k\Omega$$

(4)

10.2.8 Adjustable Reference for Tracking LDO

10.2.8.1 Design Requirements

The ATL431LI-Q1 is used as a reference voltage to help regulate a supply voltage off an LDO. By adjusting the cathode voltage, the output voltage of the LDO can vary. The TPS7B4250-Q1 is a voltage-tracking LDO with an adjustable pin which needs a precise reference voltage to change the regulate output voltage.

表 5. Design Parameters

DESIGN PARAMETER	EXAMPLE VALUE
Input Voltage	4 V to 40 V
ADJ Reference Voltage	2.500 V–18 V
Output Voltage	2.500 V–18 V
Output Current Rating	50 mA
Output Capacitor Range	1 μ F to 50 μ F
Output Capacitor ESR Range	1 m Ω to 20 Ω

10.2.8.2 Detailed Design Procedure

The goal of this design is to create a precision and stable output stage using an LDO that requires an external voltage reference such as the TPS7B4250-Q1. To begin the design process, the input and desired output voltage range is required. The ATL431LI-Q1 can be adjusted between 2.5 V and 36 V so it covers most of the output voltage rating of TPS7B4250-Q1. For reference voltage under 2.5 V, the TLV431-Q1 voltage reference can be used. The input and output capacitor must also be taken into consideration for decoupling and stability.



图 30. Feedback Quiescent Current

10.2.8.2.1 External Capacitors

An input capacitor, C_I , is recommended to buffer line influences. Connect the capacitors close to the IC pins.

The output capacitor for the TPS7B4250-Q1 device is required for stability. Without the output capacitor, the regulator oscillates. The actual size and type of the output capacitor can vary based on the application load and temperature range. The effective series resistance (ESR) of the capacitor is also a factor in the IC stability. The worst case is determined at the minimum ambient temperature and maximum load expected. To ensure stability of TPS7B4250-Q1 device, the device requires an output capacitor between 1 μ F and 50 μ F with an ESR range between 0.001 Ω and 20 Ω that can cover most types of capacitor ESR variation under the recommend operating conditions. As a result, the output capacitor selection is flexible.

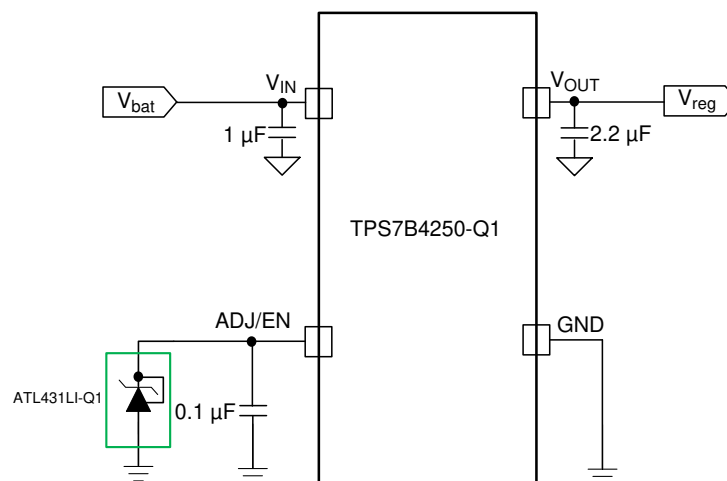
The capacitor must also be rated at all ambient temperature expected in the system. To maintain regulator stability down to -40°C , use a capacitor rated at that temperature.

10.3 System Examples

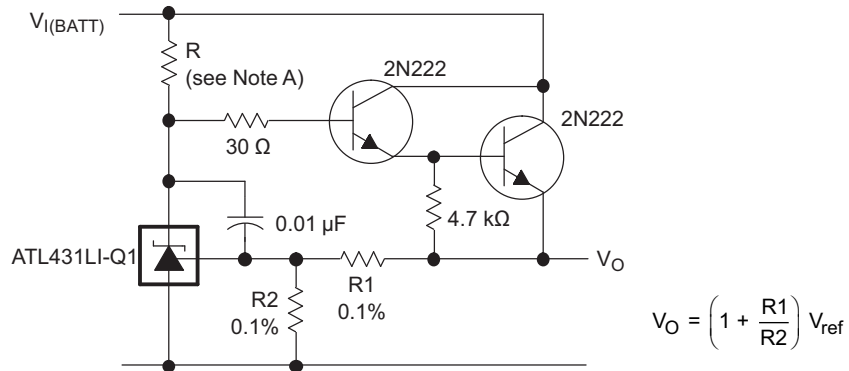

R should provide cathode current $\geq 80 \mu\text{A}$ to the ATL431LI-Q1 at minimum $V_{I(BATT)}$.

Figure 31. Precision High-Current Series Regulator

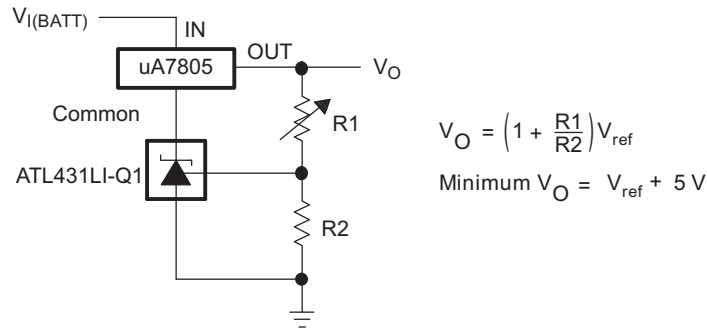

Figure 32. Output Control of a Three-Terminal Fixed Regulator

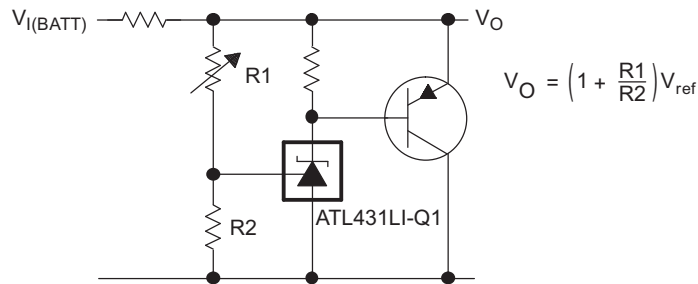
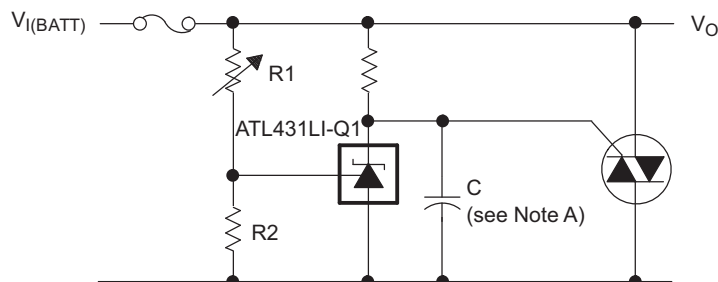

Figure 33. High-Current Shunt Regulator



Refer to the stability boundary conditions in Figure 13 to determine allowable values for C.

Figure 34. Crowbar Circuit

System Examples (continued)

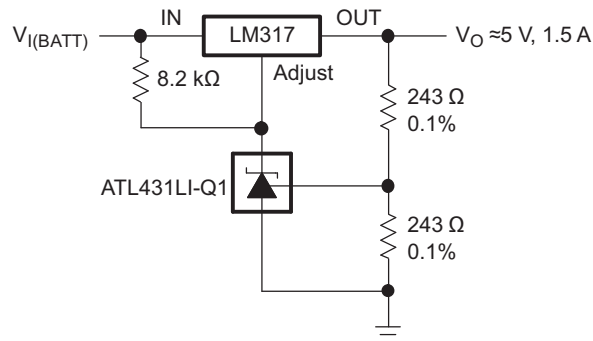
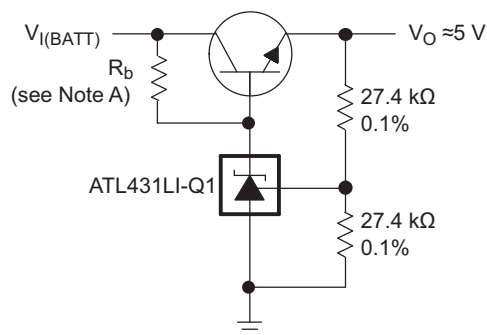

Figure 35. Precision 5-V, 1.5-A Regulator



R_b should provide cathode current $\geq 80 \mu\text{A}$ to the ATL431LI-Q1.

Figure 36. Efficient 5-V Low-Dropout (LDO) Regulator Configuration

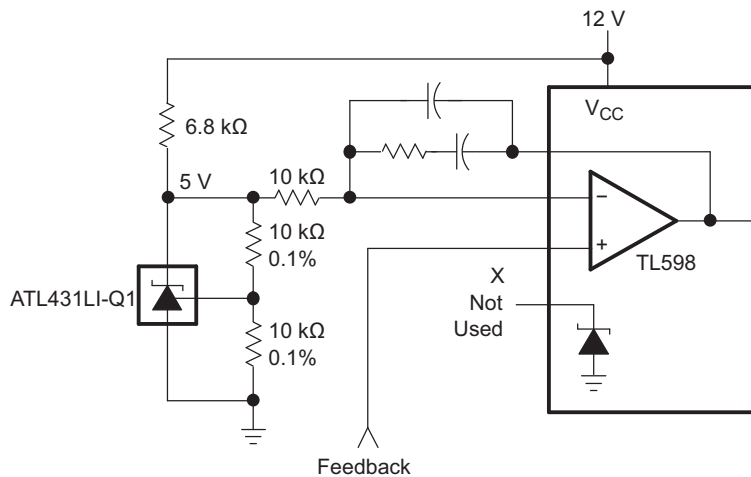
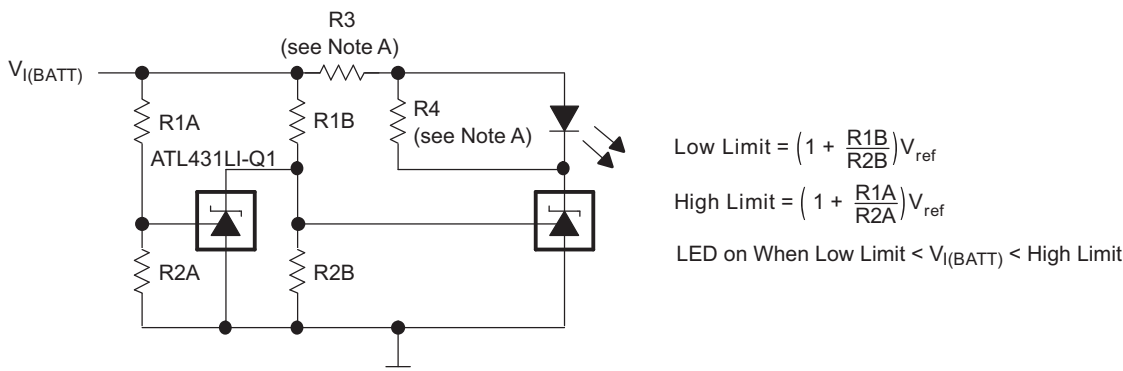

Figure 37. PWM Converter With Reference

System Examples (continued)



Select R3 and R4 to provide the desired LED intensity and cathode current $\geq 80 \mu A$ to the ATL431LI-Q1 at the available $V_{I(BATT)}$.

⊠ 38. Voltage Monitor

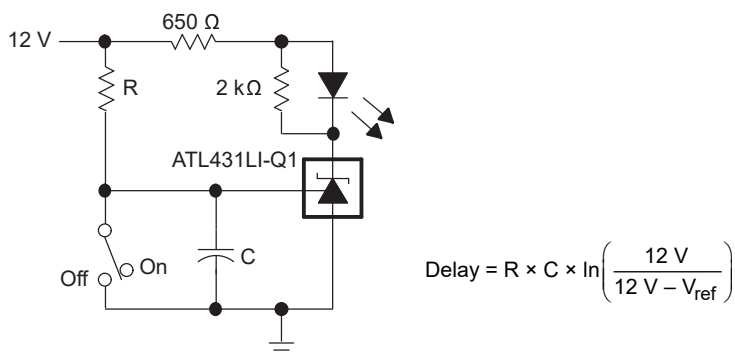

⊠ 39. Delay Timer

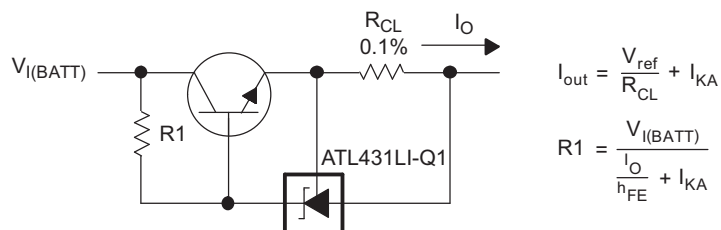

⊠ 40. Precision Current Limiter

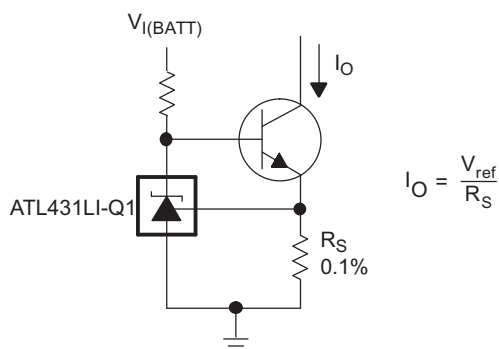

⊠ 41. Precision Constant-Current Sink

11 Power Supply Recommendations

When using ATL43xLI-Q1 as a Linear Regulator to supply a load, designers typically use a bypass capacitor on the output/cathode pin. When doing this, be sure that the capacitance is within the stability criteria shown in [Figure 13](#).

To not exceed the maximum cathode current, be sure that the supply voltage is current limited. Also, be sure to limit the current being driven into the Ref pin, so you do not exceed its absolute maximum rating.

For applications shunting high currents, pay attention to the cathode and anode trace lengths, adjusting the width of the traces to have the proper current density.

12 Layout

12.1 Layout Guidelines

Bypass capacitors must be placed as close to the part as possible. Current-carrying traces need to have widths appropriate for the amount of current they are carrying; in the case of the ATL43xLI-Q1, these currents are low.

12.2 Layout Example

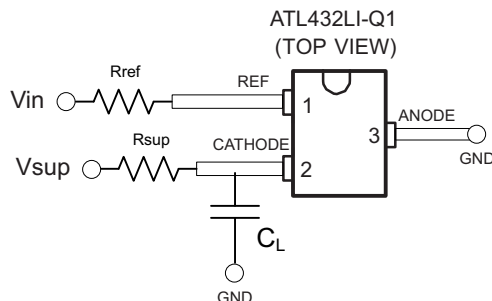

Figure 42. DBZ Layout Example

13 デバイスおよびドキュメントのサポート

13.1 デバイス・サポート

13.1.1 デバイスの項目表記

TI は、ATL43xLI-Q1 ファミリのすべての組み合わせを区別するために、接尾辞と接頭辞を割り当てています。詳細および注文可能な組み合わせについては、「付録: パッケージ・オプション」を参照してください。

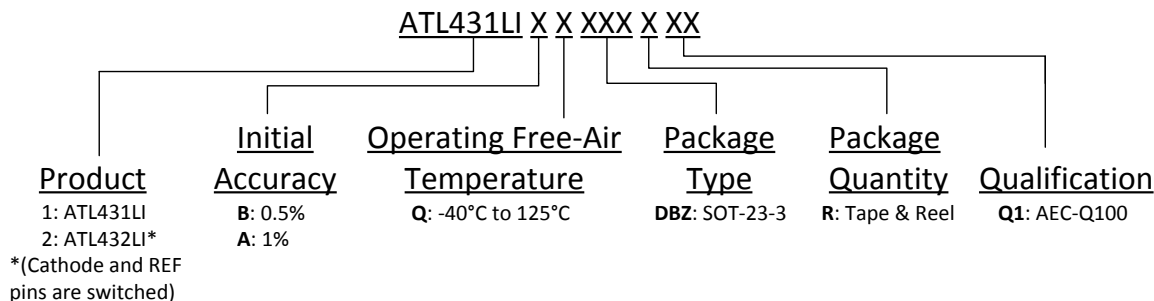

13.2 ドキュメントのサポート

13.2.1 関連資料

関連資料については、以下を参照してください。

テキサス・インスツルメンツ、[『Setting the Shunt Voltage on an Adjustable Shunt Regulator』](#) (英語)

13.3 関連リンク

次の表に、クイック・アクセス・リンクを示します。カテゴリには、技術資料、サポートおよびコミュニティ・リソース、ツールとソフトウェア、およびご注文へのクイック・アクセスが含まれます。

表 6. 関連リンク

製品	プロダクト・フォルダ	ご注文はこちら	技術資料	ツールとソフトウェア	サポートとコミュニティ
ATL431LI-Q1	ここをクリック	ここをクリック	ここをクリック	ここをクリック	ここをクリック
ATL432LI-Q1	ここをクリック	ここをクリック	ここをクリック	ここをクリック	ここをクリック

13.4 ドキュメントの更新通知を受け取る方法

ドキュメントの更新についての通知を受け取るには、[ti.com](#)のデバイス製品フォルダを開いてください。右上の「アラートを受け取る」をクリックして登録すると、変更されたすべての製品情報に関するダイジェストを毎週受け取れます。変更の詳細については、修正されたドキュメントに含まれている改訂履歴をご覧ください。

13.5 サポート・リソース

TI E2E™ support forums are an engineer's go-to source for fast, verified answers and design help — straight from the experts. Search existing answers or ask your own question to get the quick design help you need.

Linked content is provided "AS IS" by the respective contributors. They do not constitute TI specifications and do not necessarily reflect TI's views; see TI's [Terms of Use](#).

13.6 商標

E2E is a trademark of Texas Instruments.

All other trademarks are the property of their respective owners.

13.7 静電気放電に関する注意事項



すべての集積回路は、適切なESD保護方法を用いて、取扱いと保存を行うようにして下さい。

静電気放電はわずかな性能の低下から完全なデバイスの故障に至るまで、様々な損傷を与えます。高精度の集積回路は、損傷に対して敏感であり、極めてわずかなパラメータの変化により、デバイスに規定された仕様に適合しなくなる場合があります。

13.8 Glossary

[SLYZ022](#) — *TI Glossary*.

This glossary lists and explains terms, acronyms, and definitions.

14 メカニカル、パッケージ、および注文情報

以降のページには、メカニカル、パッケージ、および注文に関する情報が記載されています。この情報は、そのデバイスについて利用可能な最新のデータです。このデータは予告なく変更されることがあり、ドキュメントが改訂される場合もあります。本データシートのブラウザ版を使用されている場合は、画面左側の説明をご覧ください。

PACKAGING INFORMATION

Orderable Device	Status (1)	Package Type	Package Drawing	Pins	Package Qty	Eco Plan (2)	Lead finish/ Ball material (6)	MSL Peak Temp (3)	Op Temp (°C)	Device Marking (4/5)	Samples
ATL431LIAQDBZRQ1	ACTIVE	SOT-23	DBZ	3	3000	RoHS & Green	NIPDAU	Level-1-260C-UNLIM	-40 to 125	22XP	Samples
ATL431LIBQDBZRQ1	ACTIVE	SOT-23	DBZ	3	3000	RoHS & Green	NIPDAU	Level-1-260C-UNLIM	-40 to 125	22ZP	Samples
ATL432LIAQDBZRQ1	ACTIVE	SOT-23	DBZ	3	3000	RoHS & Green	NIPDAU	Level-1-260C-UNLIM	-40 to 125	23AP	Samples
ATL432LIBQDBZRQ1	ACTIVE	SOT-23	DBZ	3	3000	RoHS & Green	NIPDAU	Level-1-260C-UNLIM	-40 to 125	23BP	Samples

(1) The marketing status values are defined as follows:

ACTIVE: Product device recommended for new designs.

LIFEBUY: TI has announced that the device will be discontinued, and a lifetime-buy period is in effect.

NRND: Not recommended for new designs. Device is in production to support existing customers, but TI does not recommend using this part in a new design.

PREVIEW: Device has been announced but is not in production. Samples may or may not be available.

OBSELETE: TI has discontinued the production of the device.

(2) **RoHS:** TI defines "RoHS" to mean semiconductor products that are compliant with the current EU RoHS requirements for all 10 RoHS substances, including the requirement that RoHS substance do not exceed 0.1% by weight in homogeneous materials. Where designed to be soldered at high temperatures, "RoHS" products are suitable for use in specified lead-free processes. TI may reference these types of products as "Pb-Free".

RoHS Exempt: TI defines "RoHS Exempt" to mean products that contain lead but are compliant with EU RoHS pursuant to a specific EU RoHS exemption.

Green: TI defines "Green" to mean the content of Chlorine (Cl) and Bromine (Br) based flame retardants meet JS709B low halogen requirements of <=1000ppm threshold. Antimony trioxide based flame retardants must also meet the <=1000ppm threshold requirement.

(3) MSL, Peak Temp. - The Moisture Sensitivity Level rating according to the JEDEC industry standard classifications, and peak solder temperature.

(4) There may be additional marking, which relates to the logo, the lot trace code information, or the environmental category on the device.

(5) Multiple Device Markings will be inside parentheses. Only one Device Marking contained in parentheses and separated by a "-" will appear on a device. If a line is indented then it is a continuation of the previous line and the two combined represent the entire Device Marking for that device.

(6) Lead finish/Ball material - Orderable Devices may have multiple material finish options. Finish options are separated by a vertical ruled line. Lead finish/Ball material values may wrap to two lines if the finish value exceeds the maximum column width.

Important Information and Disclaimer:The information provided on this page represents TI's knowledge and belief as of the date that it is provided. TI bases its knowledge and belief on information provided by third parties, and makes no representation or warranty as to the accuracy of such information. Efforts are underway to better integrate information from third parties. TI has taken and

continues to take reasonable steps to provide representative and accurate information but may not have conducted destructive testing or chemical analysis on incoming materials and chemicals. TI and TI suppliers consider certain information to be proprietary, and thus CAS numbers and other limited information may not be available for release.

In no event shall TI's liability arising out of such information exceed the total purchase price of the TI part(s) at issue in this document sold by TI to Customer on an annual basis.

TAPE AND REEL INFORMATION



QUADRANT ASSIGNMENTS FOR PIN 1 ORIENTATION IN TAPE



*All dimensions are nominal

Device	Package Type	Package Drawing	Pins	SPQ	Reel Diameter (mm)	Reel Width W1 (mm)	A0 (mm)	B0 (mm)	K0 (mm)	P1 (mm)	W (mm)	Pin1 Quadrant
ATL431LIAQDBZRQ1	SOT-23	DBZ	3	3000	178.0	9.0	3.15	2.77	1.22	4.0	8.0	Q3
ATL431LIBQDBZRQ1	SOT-23	DBZ	3	3000	178.0	9.0	3.15	2.77	1.22	4.0	8.0	Q3
ATL432LIAQDBZRQ1	SOT-23	DBZ	3	3000	178.0	9.0	3.15	2.77	1.22	4.0	8.0	Q3
ATL432LIBQDBZRQ1	SOT-23	DBZ	3	3000	178.0	9.0	3.15	2.77	1.22	4.0	8.0	Q3

TAPE AND REEL BOX DIMENSIONS

*All dimensions are nominal

Device	Package Type	Package Drawing	Pins	SPQ	Length (mm)	Width (mm)	Height (mm)
ATL431LIAQDBZRQ1	SOT-23	DBZ	3	3000	180.0	180.0	18.0
ATL431LIBQDBZRQ1	SOT-23	DBZ	3	3000	180.0	180.0	18.0
ATL432LIAQDBZRQ1	SOT-23	DBZ	3	3000	180.0	180.0	18.0
ATL432LIBQDBZRQ1	SOT-23	DBZ	3	3000	180.0	180.0	18.0

EXAMPLE BOARD LAYOUT

DBZ0003A

SOT-23 - 1.12 mm max height

SMALL OUTLINE TRANSISTOR

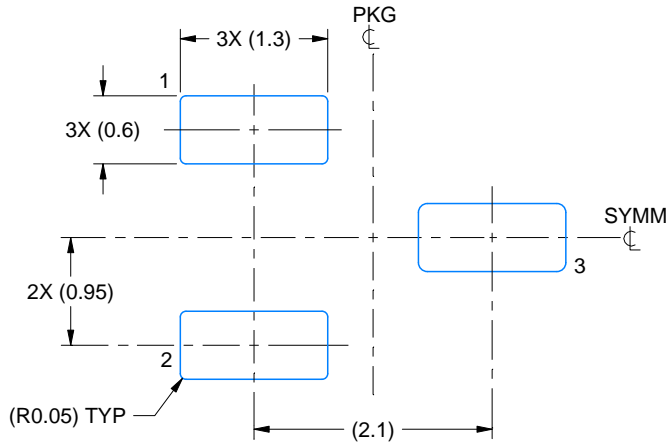

LAND PATTERN EXAMPLE
SCALE:15X

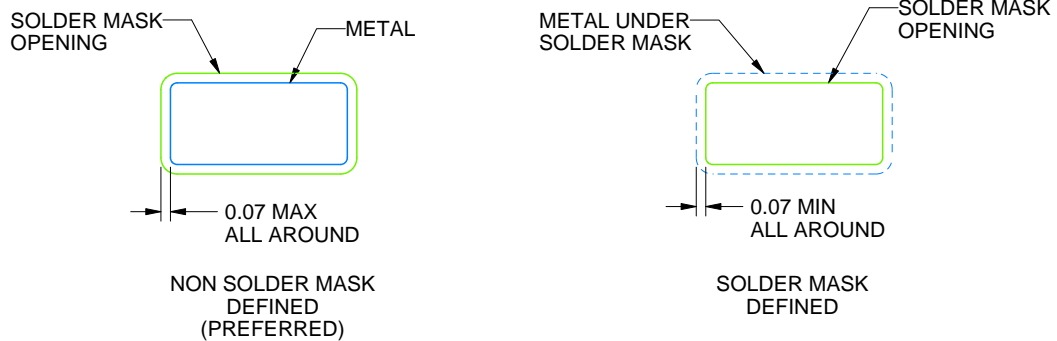

SOLDER MASK DETAILS

4214838/E 06/2024

NOTES: (continued)

- 5. Publication IPC-7351 may have alternate designs.
- 6. Solder mask tolerances between and around signal pads can vary based on board fabrication site.

EXAMPLE STENCIL DESIGN

DBZ0003A

SOT-23 - 1.12 mm max height

SMALL OUTLINE TRANSISTOR

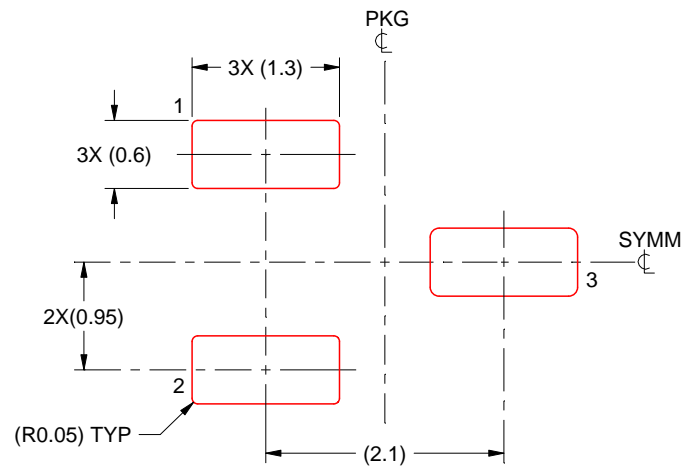

SOLDER PASTE EXAMPLE
BASED ON 0.125 THICK STENCIL
SCALE:15X

4214838/E 06/2024

NOTES: (continued)

7. Laser cutting apertures with trapezoidal walls and rounded corners may offer better paste release. IPC-7525 may have alternate design recommendations.
8. Board assembly site may have different recommendations for stencil design.

重要なお知らせと免責事項

TI は、技術データと信頼性データ(データシートを含みます)、設計リソース(リファレンス・デザインを含みます)、アプリケーションや設計に関する各種アドバイス、Web ツール、安全性情報、その他のリソースを、欠陥が存在する可能性のある「現状のまま」提供しており、商品性および特定目的に対する適合性の黙示保証、第三者の知的財産権の非侵害保証を含むいかなる保証も、明示的または黙示的にかかわらず拒否します。

これらのリソースは、TI 製品を使用する設計の経験を積んだ開発者への提供を意図したものです。(1) お客様のアプリケーションに適した TI 製品の選定、(2) お客様のアプリケーションの設計、検証、試験、(3) お客様のアプリケーションに該当する各種規格や、その他のあらゆる安全性、セキュリティ、規制、または他の要件への確実な適合に関する責任を、お客様のみが単独で負うものとし、

上記の各種リソースは、予告なく変更される可能性があります。これらのリソースは、リソースで説明されている TI 製品を使用するアプリケーションの開発の目的でのみ、TI はその使用をお客様に許諾します。これらのリソースに関して、他の目的で複製することや掲載することは禁止されています。TI や第三者の知的財産権のライセンスが付与されている訳ではありません。お客様は、これらのリソースを自身で使用した結果発生するあらゆる申し立て、損害、費用、損失、責任について、TI およびその代理人を完全に補償するものとし、TI は一切の責任を拒否します。

TI の製品は、[TI の販売条件](#)、または [ti.com](#) やかかる TI 製品の関連資料などのいずれかを通じて提供する適用可能な条項の下で提供されています。TI がこれらのリソースを提供することは、適用される TI の保証または他の保証の放棄の拡大や変更を意味するものではありません。

お客様がいかなる追加条項または代替条項を提案した場合でも、TI はそれらに異議を唱え、拒否します。

郵送先住所 : Texas Instruments, Post Office Box 655303, Dallas, Texas 75265
Copyright © 2024, Texas Instruments Incorporated