

BQ25172: 1~6 セル NiMH バッテリ向け 800mA リニア・バッテリ・チャージャ

1 特長

- 最大 30V の入力電圧に対応
- 自動スリープ・モードによる消費電力低減
 - バッテリ・リーク電流: 350nA
 - 充電ディセーブル時の入力リーク電流 85 μ A
- 1~6 セル NiMH の間欠充電をサポート
- 外付け抵抗でプログラム可能な動作
 - VSET により NiMH 直列スタックを 1s~6s に設定
 - ISET による充電電流の設定 (10mA~800mA)
 - TMR により、充電安全タイマの動作時間を 4 時間~22 時間に設定
- 高精度
 - $\pm 0.5\%$ の充電電圧精度
 - $\pm 10\%$ の充電電流精度
- 充電機能
 - NTC サーミスタ入力によるバッテリ温度監視
 - 低温および高温時の充電無効化
 - 低温時には V_{OUT_OVP} が低下
 - TS ピンによる充電機能制御
 - ステータスおよびフォルト通知用のオープン・ドレイン出力
- フォルト保護機能内蔵
 - 18V の IN 過電圧保護
 - VSET に基づく OUT 過電圧保護
 - 1000mA の過電流保護機能
 - 125°C のサーマル・レギュレーション、150°C のサーマル・シャットダウン保護
 - OUT 短絡保護
 - VSET、ISET、TMR ピンの短絡 / 開放保護

2 アプリケーション

- フリート管理、アセット追跡
- ガス検出器
- 電子 POS (ePOS)
- 美容および理容
- 電動歯ブラシ
- パルス・オキシメータ (血中酸素飽和度計)
- 血糖値測定器
- 赤外線温度計

3 概要

BQ25172 は、産業用および医療用アプリケーション向けの 1~6 セル NiMH バッテリに対応する統合型 800mA リニア・チャージャです。このデバイスには、バッテリを充電する電源出力が 1 つあります。バッテリと並列にシステム負荷を接続できますが、平均システム負荷によって安全タイマ設定時間内でのバッテリのフル充電を妨げないという条件があります。システム負荷をバッテリと並列に配置した場合、充電電流はシステムとバッテリの間で共有されません。

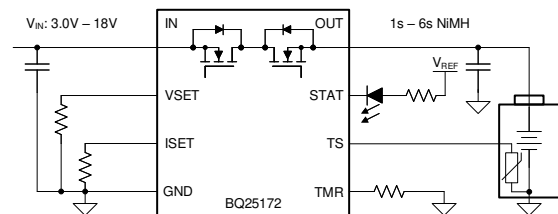
このデバイスは、定電流モードでのみ NiMH セルを充電し、プログラム可能なタイマが完了するか、またはバッテリ電圧が V_{OUT_OVP} スレッシュホルドを超えると、充電サイクルを終了します。すべての充電フェーズで、内部制御ループが IC 接合部の温度を監視して、内部の温度スレッシュホルド (T_{REG}) を超えた場合は、充電電流を減少させます。

充電器の電源段および充電電流センス機能がすべて統合されています。この充電器には、高精度電流、充電ステータスの表示、およびタイマによる充電終了の機能があります。直列セルの数、充電電流、充電タイマは、外付けの抵抗によりプログラムできます。間欠充電を使用すると、NiMH バッテリの電圧が再充電スレッシュホルドを下回ったときに、タイマの時間を短縮して自動的に再充電します。

製品情報

部品番号	パッケージ ⁽¹⁾	本体サイズ (公称)
BQ25172	WSON (8)	2.0mm × 2.0mm

- (1) 利用可能なパッケージについては、このデータシートの末尾にある注文情報を参照してください。



概略回路図



Table of Contents

1 特長	1	7.4 Device Functional Modes.....	16
2 アプリケーション	1	8 Application and Implementation	17
3 概要	1	8.1 Application Information.....	17
4 Revision History	2	8.2 Typical Applications.....	17
5 Pin Configuration and Functions	3	9 Power Supply Recommendations	20
6 Specifications	4	10 Layout	20
6.1 Absolute Maximum Ratings.....	4	10.1 Layout Guidelines.....	20
6.2 ESD Ratings.....	4	10.2 Layout Example.....	20
6.3 Recommended Operating Conditions.....	4	11 Device and Documentation Support	21
6.4 Thermal Information.....	5	11.1 Device Support.....	21
6.5 Electrical Characteristics.....	6	11.2 Receiving Notification of Documentation Updates..	21
6.6 Timing Requirements.....	7	11.3 サポート・リソース.....	21
6.7 Typical Characteristics.....	8	11.4 Trademarks.....	21
7 Detailed Description	9	11.5 Electrostatic Discharge Caution.....	21
7.1 Overview.....	9	11.6 Glossary.....	21
7.2 Functional Block Diagram.....	10	12 Mechanical, Packaging, and Orderable Information	22
7.3 Feature Description.....	11		

4 Revision History

資料番号末尾の英字は改訂を表しています。その改訂履歴は英語版に準じています。

DATE	REVISION	NOTES
June 2022	*	Initial Release

5 Pin Configuration and Functions

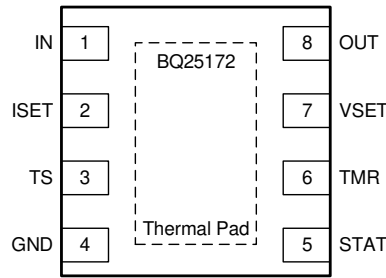


図 5-1. DSG Package WSON 8-Pin Top View

表 5-1. Pin Functions

PIN		I/O	DESCRIPTION
NAME	NUMBER		
IN	1	P	Input power, connected to external DC supply. Bypass IN with a $\geq 1\text{-}\mu\text{F}$ capacitor to GND, placed close to the IC.
ISET	2	I	Programs the device charge current. External resistor from ISET to GND defines charge current value. Expected range is 30 k Ω (10 mA) to 375 Ω (800 mA). $I_{\text{CHG}} = K_{\text{ISET}} / R_{\text{ISET}}$.
TS	3	I	Temperature qualification voltage input. Connect a negative temperature coefficient (NTC) thermistor directly from TS to GND (AT103-2 recommended). Charge suspends when the TS pin voltage is out of range. $V_{\text{OUT_OVP}}$ is reduced in cool region. If TS function is not needed, connect an external 10-k Ω resistor from this pin to GND. Pulling $V_{\text{TS}} < V_{\text{TS_ENZ}}$ disables the charger.
GND	4	–	Ground pin
STAT	5	O	Open drain charge status indication output. Connect to the pullup rail via a 10-k Ω resistor. LOW indicates charge in progress. HIGH indicates charge complete or charge disabled. When a fault condition is detected, the STAT pin blinks at 1 Hz.
TMR	6	I	Connect to a pulldown resistor to program charge safety timer duration. Valid resistor range is 3.6 k Ω to 36 k Ω . Refer to セクション 7.3.1.2 .
VSET	7	I	Programs the number of series NiMH cells. Valid resistor range is 3.6 k Ω to 62 k Ω . Recommend using a $\pm 1\%$ tolerance resistor with < 200 ppm/ $^{\circ}\text{C}$ temperature coefficient. Refer to セクション 7.3.1.3 .
OUT	8	P	Battery connection. System load may be connected in parallel to the battery. Bypass OUT with a $\geq 1\text{-}\mu\text{F}$ capacitor to GND, placed close to the IC.
Thermal Pad	—	—	Exposed pad beneath the IC for heat dissipation. Solder thermal pad to the board with vias connecting to solid GND plane.

6 Specifications

6.1 Absolute Maximum Ratings

over operating free-air temperature range (unless otherwise noted)⁽¹⁾

		MIN	MAX	UNIT
Voltage	IN	-0.3	30	V
Voltage	OUT	-0.3	13	V
Voltage	ISET, STAT, TMR, TS, VSET	-0.3	5.5	V
Output Sink Current	STAT		5	mA
Junction temperature, T _J		-40	150	°C
Storage temperature, T _{stg}		-65	150	°C

- (1) Operation outside the Absolute Maximum Ratings may cause permanent device damage. Absolute maximum ratings do not imply functional operation of the device at these or any other conditions beyond those listed under Recommended Operating Conditions. If briefly operating outside the Recommended Operating Conditions but within the Absolute Maximum Ratings, the device may not sustain damage, but it may not be fully functional. Operating the device in this manner may affect device reliability, functionality, performance, and shorten the device lifetime.

6.2 ESD Ratings

			VALUE	UNIT
V _(ESD)	Electrostatic discharge	Human body model (HBM), per ANSI/ESDA/ JEDEC JS-001, all pins ⁽¹⁾	±2500	V
		Charged device model (CDM), per JEDEC specification JESD22-C101, all pins ⁽²⁾	±1500	

- (1) JEDEC document JEP155 states that 500-V HBM allows safe manufacturing with a standard ESD control process.
 (2) JEDEC document JEP157 states that 250-V CDM allows safe manufacturing with a standard ESD control process.

6.3 Recommended Operating Conditions

over operating free-air temperature range (unless otherwise noted)

		MIN	NOM	MAX	UNIT
V _{IN}	Input voltage	3.0		18	V
V _{OUT}	Output voltage			10.5	V
I _{OUT}	Output current			0.8	A
T _J	Junction temperature	-40		125	°C
C _{IN}	IN capacitor	1			μF
C _{OUT}	OUT capacitor	1			μF
R _{TMR}	TMR resistor	3.6		36	kΩ
R _{VSET}	VSET resistor	3.6		62	kΩ
R _{TMR_VSET_TOL}	Tolerance for TMR, and VSET resistors	-1		1	%
R _{TMR_VSET_TEMPCO}	Temperature coefficient for TMR, and VSET resistors			200	ppm/°C
R _{ISET}	ISET resistor	0.375		30	kΩ
R _{TS}	TS thermistor resistor (recommend 103AT-2)		10		kΩ

6.4 Thermal Information

THERMAL METRIC ⁽¹⁾		BQ25172	UNIT
		DSG(WSON)	
		8 PINS	
$R_{\theta JA}$	Junction-to-ambient thermal resistance (JEDEC ⁽¹⁾)	75.2	°C/W
$R_{\theta JC(top)}$	Junction-to-case (top) thermal resistance	93.4	°C/W
$R_{\theta JB}$	Junction-to-board thermal resistance	41.8	°C/W
Ψ_{JT}	Junction-to-top characterization parameter	3.8	°C/W
Ψ_{JB}	Junction-to-board characterization parameter	41.7	°C/W
$R_{\theta JC(bot)}$	Junction-to-case (bottom) thermal resistance	17.0	°C/W

(1) For more information about traditional and new thermal metrics, see the [Semiconductor and IC Package Thermal Metrics](#) application report.

6.5 Electrical Characteristics

3.0V < V_{IN} < 18V and V_{IN} > V_{OUT} + V_{SLEEP}, T_J = -40°C to +125°C, and T_J = 25°C for typical values (unless otherwise noted)

PARAMETER		TEST CONDITIONS	MIN	TYP	MAX	UNIT
QUIESCENT CURRENTS						
I _{Q_OUT}	Quiescent output current (OUT)	OUT = 4.2V, IN floating or IN = 0V - 5V, Charge Disabled, T _J = 25 °C		0.350	0.6	μA
		OUT = 4.2V, IN floating or IN = 0V - 5V, Charge Disabled, T _J < 105 °C		0.350	0.8	μA
I _{Q_OUT}	Quiescent output current (OUT)	OUT = 8.4V, IN floating or IN = 0V - 14V, Charge Disabled, T _J = 25 °C		0.8	1.2	μA
		OUT = 8.4V, IN floating or IN = 0V - 14V, Charge Disabled, T _J < 105 °C		0.8	1.5	μA
I _{SD_IN_TS}	Shutdown input current (IN) with charge disabled via TS pin	IN = 5V, Charge Disabled (V _{TS} < V _{TS_ENZ}), no battery		80	110	μA
I _{STANDBY_IN}	Standby input current (IN) with charge terminated	IN = 5V, Charge Enabled, charge terminated		190		μA
I _{STANDBY_IN}	Standby input current (IN) with charge terminated	IN = 14V, Charge Enabled, charge terminated		230		μA
I _{Q_IN}	Quiescent input current (IN)	IN = 5V, OUT = 3.8V, Charge Enabled, I _{CHG} = 0A		0.45	0.6	mA
I _{Q_IN}	Quiescent input current (IN)	IN = 14V, OUT = 7.6V, Charge Enabled, I _{CHG} = 0A		0.45	0.6	mA
INPUT						
V _{IN_OP}	IN operating range		3.0		18	V
V _{IN_LOVV}	IN voltage to start charging	IN rising	3.05	3.09	3.15	V
V _{IN_LOVV}	IN voltage to stop charging	IN falling	2.80	2.95	3.10	V
V _{SLEEPZ}	Exit sleep mode threshold	IN rising, V _{IN} - V _{OUT} , OUT = 4V	95	135	175	mV
V _{SLEEP}	Sleep mode threshold hysteresis	IN falling, V _{IN} - V _{OUT} , OUT = 4V		80		mV
V _{IN_OV}	VIN overvoltage rising threshold	IN rising	18.1	18.4	18.7	V
V _{IN_OVZ}	VIN overvoltage falling threshold	IN falling		18.2		V
CONFIGURATION PINS SHORT/OPEN PROTECTION						
R _{ISET_SHORT}	Resistor value considered short	R _{ISET} below this at startup, charger does not initiate charge, power cycle or TS toggle to reset			350	Ω
R _{VSET_SHORT}	Resistor value considered short	R _{VSET} below this at startup, charger does not initiate charge, power cycle or toggle to reset			2.8	kΩ
R _{VSET_OPEN}	Resistor value considered open	R _{VSET} above this at startup, charger does not initiate charge, power cycle or toggle to reset	80			kΩ
R _{TMR_SHORT}	Resistor value considered short	R _{TMR} below this at startup, charger latches off, power cycle or TS toggle to reset			2.8	kΩ
R _{TMR_OPEN}	Resistor value considered open	R _{TMR} above this at startup, charger latches off, power cycle or TS toggle to reset	45			kΩ
BATTERY CHARGER						
I _{CHG_RANGE}	Typical charge current regulation range		10		800	mA
K _{ISET}	Charge current setting factor, I _{CHG} = K _{ISET} / R _{ISET}	10mA < I _{CHG} < 800mA	270	300	330	AΩ
I _{CHG_ACC}	Charge current accuracy	R _{ISET} = 375Ω, OUT = 3.8V	720	800	880	mA
		R _{ISET} = 600Ω, OUT = 3.8V	450	500	550	mA
		R _{ISET} = 3.0kΩ, OUT = 3.8V	90	100	110	mA
		R _{ISET} = 30kΩ, OUT = 3.8V	9	10	11	mA

6.5 Electrical Characteristics (continued)

3.0V < V_{IN} < 18V and V_{IN} > V_{OUT} + V_{SLEEP}, T_J = -40°C to +125°C, and T_J = 25°C for typical values (unless otherwise noted)

PARAMETER		TEST CONDITIONS	MIN	TYP	MAX	UNIT
V _{RECHG}	Battery recharge threshold, per cell	OUT falling, VSET configured for 2-cell	1.305	1.330	1.355	V
R _{ON}	Charging path FET on-resistance	IOU _T = 400mA, T _J = 25°C		845	1000	mΩ
		IOU _T = 400mA, T _J = -40 - 125°C		845	1450	mΩ
BATTERY CHARGER PROTECTION						
V _{OUT_OVP}	OUT overvoltage rising threshold, per cell	VOU _T rising, TS normal	1.65	1.70	1.75	V
V _{OUT_OVP}	OUT overvoltage falling threshold, per cell	VOU _T falling, TS normal	1.40	1.45	1.50	V
V _{OUT_OVP_TSCOO}	OUT overvoltage rising threshold, per cell	VOU _T rising, TS in cool range	1.45	1.50	1.55	V
V _{OUT_OVP_TSCOO}	OUT overvoltage falling threshold, per cell	VOU _T falling, TS in cool range	1.30	1.35	1.40	V
I _{OUT_OCP}	Output current limit threshold	IOU _T rising	0.9	1	1.1	A
TEMPERATURE REGULATION AND TEMPERATURE SHUTDOWN						
T _{REG}	Typical junction temperature regulation			125		°C
T _{SHUT}	Thermal shutdown rising threshold	Temperature increasing		150		°C
	Thermal shutdown falling threshold	Temperature decreasing		135		°C
BATTERY-PACK NTC MONITOR						
I _{TS_BIAS}	TS nominal bias current		36.5	38	39.5	μA
V _{COLD}	Cold temperature threshold	TS pin voltage rising (approx. 0°C)	0.99	1.04	1.09	V
	Cold temperature exit threshold	TS pin voltage falling (approx. 4°C)	0.83	0.88	0.93	V
V _{COOL}	Cool temperature threshold; V _{OUT_OVP} reduced	TS pin voltage rising (approx. 10°C)	650	680	710	mV
	Cool temperature exit threshold; V _{OUT_OVP} returns to normal	TS pin voltage falling (approx. 13°C)	580	610	640	mV
V _{HOT}	Hot temperature threshold	TS pin voltage falling (approx. 45°C)	176	188	200	mV
	Hot temperature exit threshold	TS pin voltage rising (approx. 40°C)	208	220	232	mV
V _{TS_ENZ}	Charge Disable threshold. Crossing this threshold shall shutdown IC	TS pin voltage falling	40	50	60	mV
V _{TS_EN}	Charge Enable threshold. Crossing this threshold shall restart IC operation	TS pin voltage rising	65	75	85	mV
V _{TS_CLAMP}	TS maximum voltage clamp	TS pin open-circuit (float)	2.3	2.6	2.9	V
LOGIC OUTPUT PIN (STAT)						
V _{OL}	Output low threshold level	Sink current = 5mA			0.4	V
I _{OUT_BIAS}	High-level leakage current	Pull up rail 3.3V			1	μA

6.6 Timing Requirements

		MIN	NOM	MAX	UNIT
BATTERY CHARGER					
t _{TS_DUTY_ON}	TS turn-on time during TS duty cycle mode		100		ms
t _{TS_DUTY_OFF}	TS turn-off time during TS duty cycle mode		2		s
t _{OUT_OCP_DGL}	Deglintch time for I _{OUT_OCP} , IOU _T rising		100		μs
t _{SAFETY}	Charge safety timer accuracy, R _{TMR} = 18kΩ	9.5	10	10.5	hr
t _{INTERMITTENT}	Commercial Intermittent charge safety timer (NiMH), as percentage of t _{SAFETY}		20		%

6.7 Typical Characteristics

$C_{IN} = 1 \mu F$, $C_{OUT} = 1 \mu F$, $V_{IN} = 5 V$, $V_{OUT} = 3.8 V$, Temperature = Ambient (unless otherwise specified)

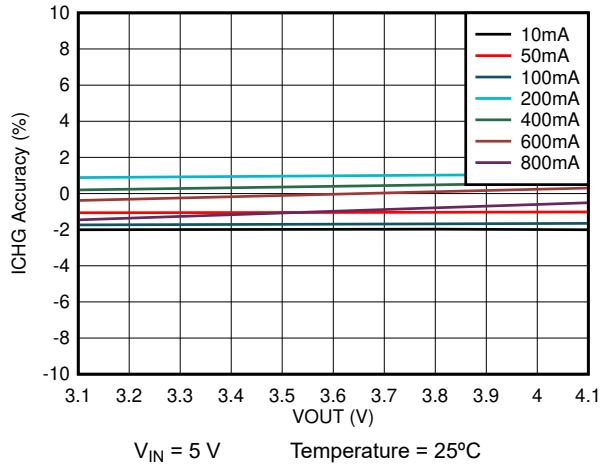


Figure 6-1. ICHG Accuracy vs. Output Voltage

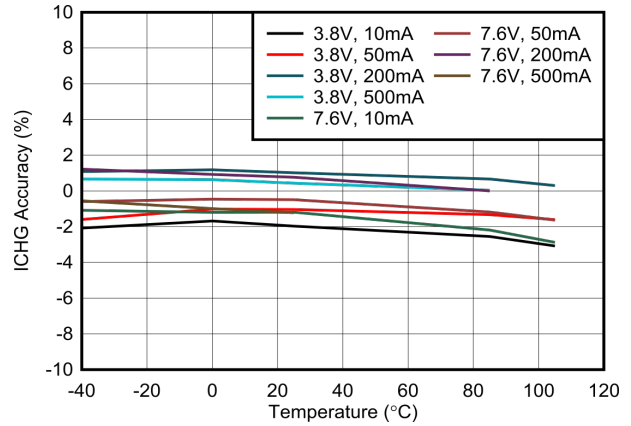


Figure 6-2. ICHG Accuracy vs. Temperature

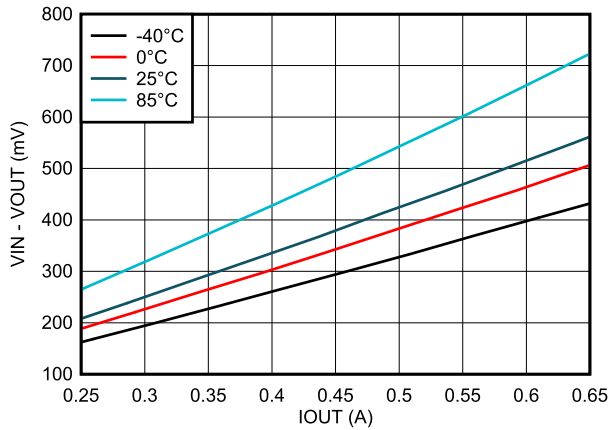


Figure 6-3. Dropout Voltage vs. Output Current

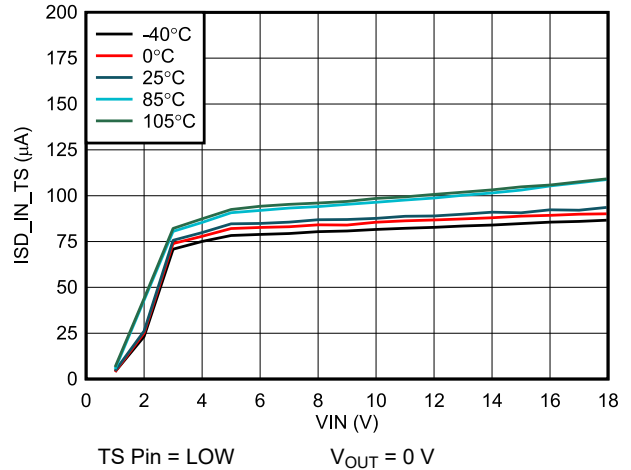


Figure 6-4. Input Shutdown Current vs. Input Voltage

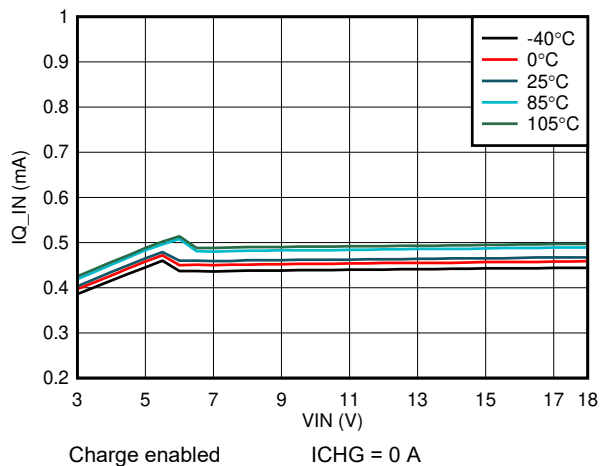


Figure 6-5. Input Quiescent Current vs. Input Voltage

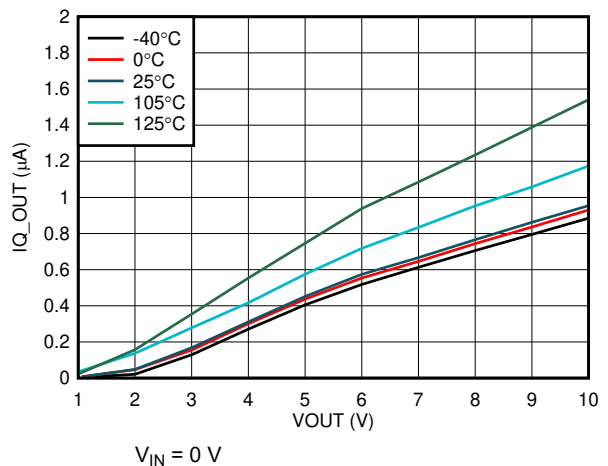


Figure 6-6. Output Quiescent Current vs. Output Voltage

7 Detailed Description

7.1 Overview

The BQ25172 is an integrated 800-mA linear charger for 1-cell to 6-cell NiMH battery applications. The device has a single power output that charges the battery. When the system load is placed in parallel with the battery, the input current is shared between the system and the battery.

The device charges a NiMH battery in constant current mode only and terminates the charge cycle when the programmable timer, t_{SAFETY} , expires or the battery voltage exceeds the $V_{\text{OUT_OVP}}$ threshold. An optional intermittent charging phase can be programmed to automatically recharge the NiMH battery for a reduced timer duration once its voltage falls below V_{RECHG} .

The charger includes flexibility in programming of the charge current, charge safety timer duration, and series cell-count. This charger is designed to work with a standard USB connection or dedicated charging adapter (DC output).

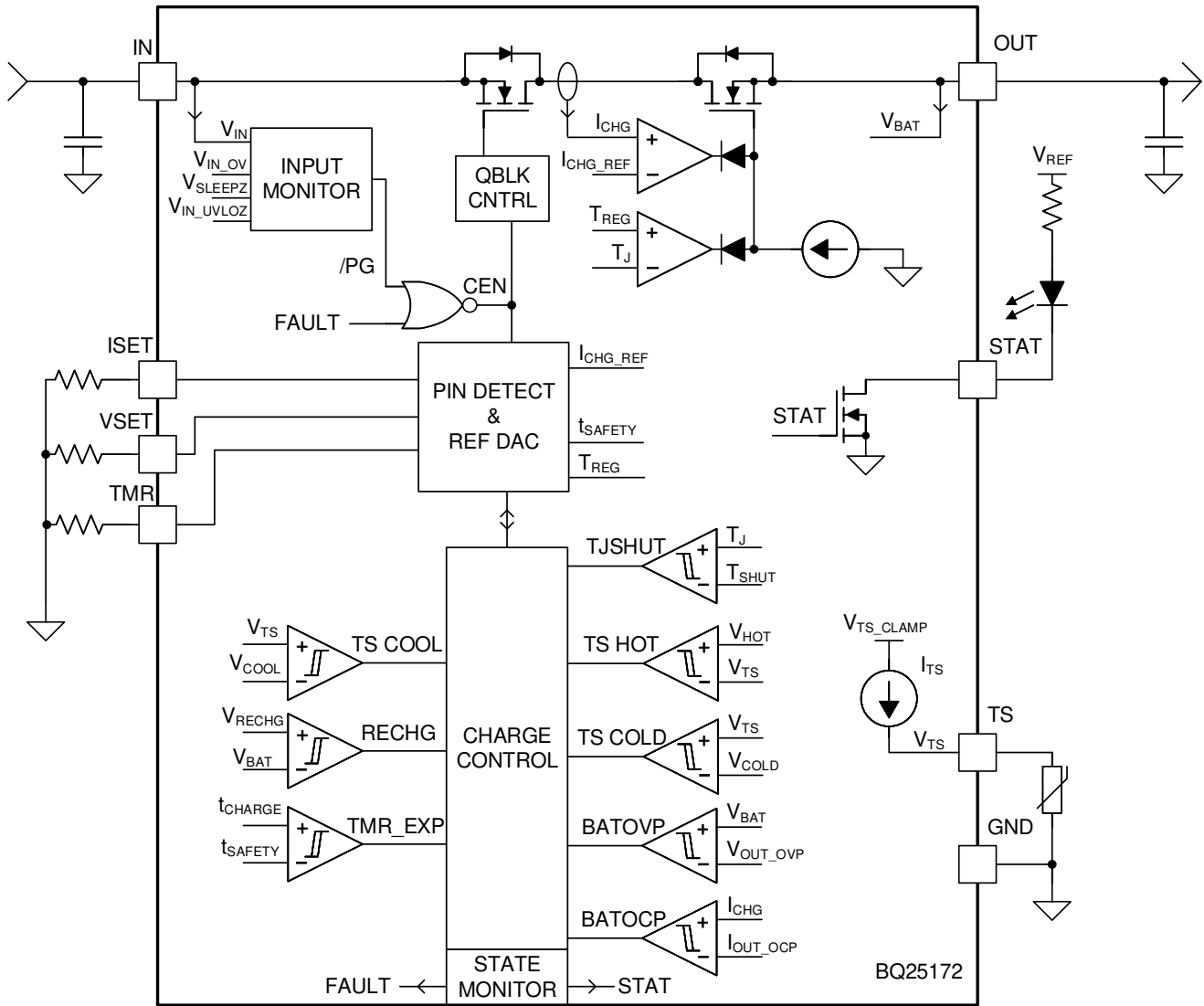
The charger also comes with a full set of safety features: battery temperature monitoring, overvoltage protection, charge safety timer, and configuration pin (VSET, ISET, TMR) short and open protection. Upon application of a valid input power source, the configuration pins are checked for short and open circuits. All of these features and more are described in detail in the following sections.

The charger is designed for a single path from the input to the output to charge the battery. Once the input adapter has been connected, the charge current is applied and the safety timer is started. The charge current is programmed using the ISET pin. The safety timer is programmed by the TMR pin.

Power dissipation in the IC is greatest at high charge currents and low battery voltages. If the IC temperature reaches T_{REG} , the IC enters thermal regulation, slows the timer clock by half, and reduces the charge current as needed to keep the temperature from rising any further.

Further details are described in [セクション 7.3](#).

7.2 Functional Block Diagram



7.3 Feature Description

7.3.1 Device Power Up from Input Source

When an input source is plugged in and charge is enabled ($V_{TS} > V_{TS_EN}$), the device checks the input source voltage to turn on all the bias circuits. It detects and sets the charge current, safety timer length, and series cell-count before the linear regulator is started. The power-up sequence from input source is as listed:

1. ISET pin detection
2. TMR pin detection to select charge timer
3. VSET pin detection to select battery stack configuration
4. Charger power up

7.3.1.1 ISET Pin Detection

After a valid VIN is plugged in and $V_{TS} > V_{TS_EN}$, the device checks the resistor on the ISET pin for a short circuit ($R_{ISET} < R_{ISET_SHORT}$). If a short condition is detected, the charger remains in the FAULT state until the input or TS pin is toggled. If the ISET pin is open-circuit, the charger proceeds through pin detection and starts the charger with no charge current. The ISET pin is monitored while charging and changes in R_{ISET} while the charger is operating immediately translates to changes in charge current.

An external pull-down resistor ($\pm 1\%$ or better is recommended to minimize charge current error) from the ISET pin to GND sets the charge current as:

$$I_{CHG} = \frac{K_{ISET}}{R_{ISET}} \tag{1}$$

where:

- I_{CHG} is the desired charge current
- K_{ISET} is a gain factor found in the electrical characteristics
- R_{ISET} is the pull-down resistor from the ISET pin to GND

For charge currents below 50 mA, an extra RC circuit is recommended on ISET to achieve a more stable current signal. For greater accuracy at lower currents, part of the current-sensing FET is disabled to give better resolution.

7.3.1.2 TMR Pin Detection

The TMR pin is used to program the safety timer using a $\pm 1\%$ pull-down resistor. The available pull-down resistors and corresponding timer lengths are listed in the following table.

表 7-1. TMR Pin Resistor Value Table

RESISTOR	CHARGE TIMER (HR)
> 45 kΩ	No charge (open-circuit)
36 kΩ	4 hr
27 kΩ	6 hr
24 kΩ	8 hr
18 kΩ	10 hr
15 kΩ	12 hr
11 kΩ	14 hr
8.2 kΩ	16 hr
6.2 kΩ	18 hr
4.7 kΩ	20 hr
3.6 kΩ	22 hr

表 7-1. TMR Pin Resistor Value Table (continued)

RESISTOR	CHARGE TIMER (HR)
< 3.0 kΩ	No charge (short-circuit)

If either a short- or open-circuit condition is detected, the charger stops operation and remains in the FAULT state until the input or TS pin is toggled.

Once a value has been detected, it is latched in and the pin is not continuously monitored during operation. A change in this pin is not acknowledged by the IC until the input supply or TS pin is toggled.

7.3.1.3 VSET Pin Detection

The VSET pin is used to program the device cell configuration using a $\pm 1\%$ pulldown resistor. The available pulldown resistors and corresponding cell configurations are listed in the following table.

表 7-2. VSET Pin Resistor Value Table

RESISTOR	CELL COUNT
> 80 Ω	No charge (open-circuit)
62 kΩ	1-cell
47 kΩ	1-cell + intermittent charge
36 kΩ	2-cell
27 kΩ	2-cell + intermittent charge
24 kΩ	3-cell
18 kΩ	3-cell + intermittent charge
15 kΩ	4-cell
11 kΩ	4-cell + intermittent charge
8.2 kΩ	5-cell
6.2 kΩ	5-cell + intermittent charge
4.7 kΩ	6-cell
3.6 kΩ	6-cell + intermittent charge
< 3.0 kΩ	No charge (short-circuit)

If either a short- or open-circuit condition is detected, the charger stops operation and remains in the FAULT state until the input or TS pin is toggled.

Once a valid resistor value has been detected, the corresponding cell configuration is latched in and the pin is not continuously monitored during operation. A change in this pin is not acknowledged by the IC until the input supply or TS pin is toggled.

7.3.1.4 Charger Power Up

After ISET, TMR, and VSET pin resistor values have been validated, the device proceeds to enable the charger. For more info see [セクション 7.3.2.1](#).

7.3.2 Battery Charging Features

When charge is enabled ($V_{TS} > V_{TS_EN}$), the device automatically completes a charging cycle according to the settings on the ISET, TMR, and VSET pins. Charging is terminated when the charge safety timer expires or battery voltage exceeds V_{OUT_OVP} .

7.3.2.1 NiMH Battery Charging Profile

The device charges NiMH batteries in constant current mode only. The charge current programmed by ISET is the only current applied over the charging cycle, as shown in [図 7-1](#). The charge termination method for the device is timer-based. The charge safety timer, t_{SAFETY} , sets the charging duration. Programming the charge safety timer is done with a pulldown resistor on the TMR pin.

Intermittent charging is designed to replenish the natural self-discharge of NiMH cells by restarting a short charge cycle (20% of t_{SAFETY}) when the output voltage falls below the V_{RECHG} threshold. If the intermittent charging function is disabled and a full charge cycle has been completed (safety timer expired with V_{OUT} above V_{RECHG}), the device does not start a new charge cycle automatically and requires input supply or TS pin toggle to initiate a new charge cycle.

If battery voltage is above V_{RECHG} at power up, the battery is considered full and the device does not charge. Once the battery voltage falls below V_{RECHG} , the device automatically begins charging. If the intermittent charging function is disabled, a single charge cycle is initiated with the safety timer duration programmed by the TMR pin. If intermittent charging is enabled, an intermittent charge cycle is initiated for 20% of the TMR programmed value.

When the charge timer (full-length or intermittent) expires, the battery voltage is checked again. If the battery voltage is below V_{RECHG} , a fault is reported through the STAT pin and further charging is prevented. If the charge timer expires with V_{OUT} above V_{RECHG} , the STAT pin indicates charge completed. In the case where the TS fault is within the cool threshold, V_{OUT_OVP} is automatically reduced to $V_{OUT_OVP_TSCOOL}$ voltage.

If the charger is in thermal regulation during charging, the actual charging current will be less than the programmed value. Termination by timer is still enabled, but the charging safety timer is counted at half the clock rate. For more information, refer to [セクション 7.3.2.2](#).

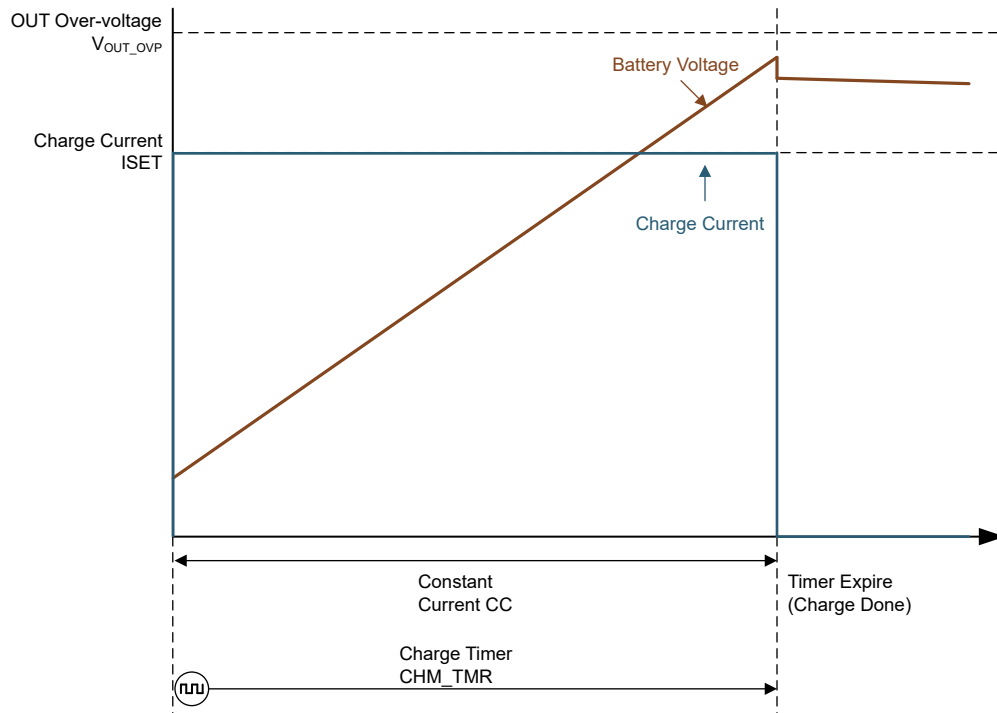


図 7-1. NIMH Battery Charging Profile with Intermittent Charging Disabled

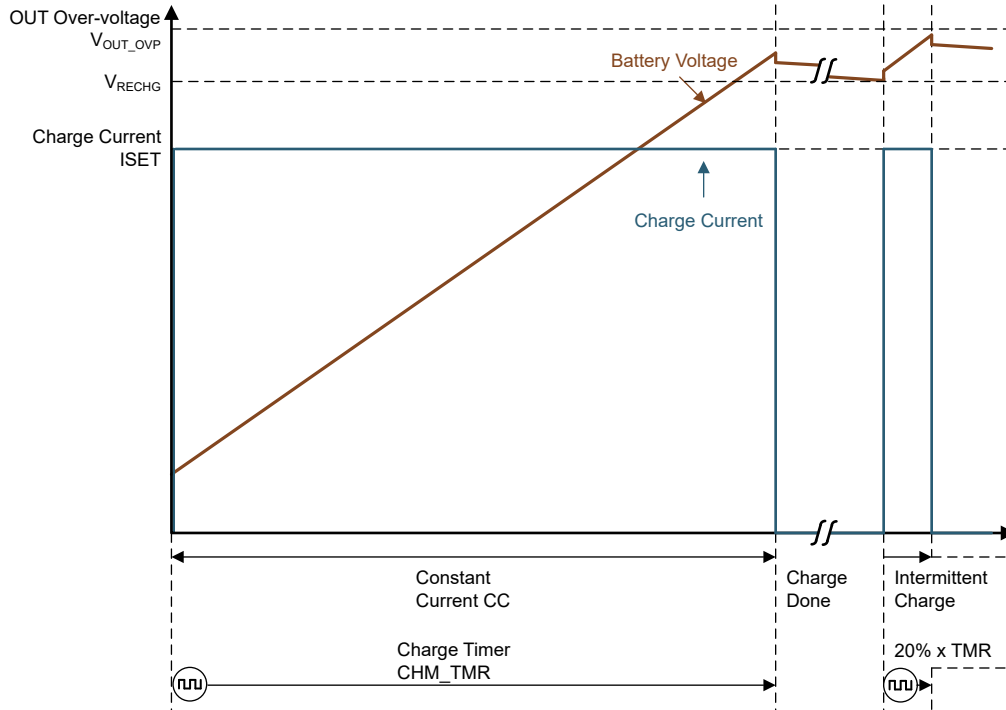


Figure 7-2. NiMH Battery Charging Profile with Intermittent Charging Enabled

7.3.2.2 Charging Safety Timers

The device has built-in safety timers to prevent an extended charging cycle due to abnormal battery conditions. When the safety timer expires, the charge cycle ends.

During thermal regulation, the safety timer counts at half the clock rate as the actual charge current is likely to be below the I_{SET} setting. For example, if the charger is in thermal regulation throughout the whole charging cycle and the safety timer is 10 hours, then the timer will expire in 20 hours.

During faults which disable charging, such as VIN OVP, BAT OVP, TSHUT, or TS faults, the timer is suspended. If the charging cycle is stopped and started again, the timer is reset (toggle of the TS pin restarts the timer).

The safety timer restarts counting when the charging cycle stops and restarts. This can occur as a result of the TS pin being toggled, the battery falling below the recharge threshold, or the input supply being toggled.

7.3.2.3 Battery Cold, Hot Temperature Qualification (TS Pin)

While charging, the device continuously monitors battery temperature by sensing the voltage at the TS pin. A negative temperature coefficient (NTC) thermistor should be connected between the TS and GND pins (recommend: 103AT-2). If temperature sensing is not required in the application, connect a fixed 10-k Ω resistor from the TS pin to GND to allow normal operation. Battery charging is allowed when the TS pin voltage falls between the V_{COLD} and V_{HOT} thresholds (typically 0°C to 45°C).

If the TS pin indicates battery temperature is outside this range, the device stops charging and enters the Standby state. Once battery temperature returns to normal conditions, charging resumes automatically.

In addition to battery temperature sensing, the TS pin can be used to disable the charger at any time by pulling TS voltage below V_{TS_ENZ} . The device disables the charger and consumes $I_{SD_IN_TS}$ from the input supply. In order to minimize quiescent current, the TS current source (I_{TS_BIAS}) is duty-cycled, with an on time of $t_{TS_DUTY_ON}$ and an off time of $t_{TS_DUTY_OFF}$. After the TS pin pulldown is released, the device may take up to $t_{TS_DUTY_OFF}$ to turn I_{TS_BIAS} back on. After the source is turned on, the TS pin voltage goes above V_{TS_EN} and reenables charger operation. The device treats this TS pin toggle as an input supply toggle, triggering a device power up from input source (see [セクション 7.3.1](#)).

7.3.3 Status Outputs (STAT)

7.3.3.1 Charging Status Indicator (STAT)

The device indicates the charging state on the open-drain STAT pin as listed in the following table. This pin can drive an LED.

表 7-3. STAT Pin States

CHARGING STATE	STAT PIN STATE
Charge completed (TMR_EXP), charger in Sleep mode or charge disabled	High
Charge in progress (including intermittent charge active)	Low
Fault (VIN OVP, BAT OVP, BAT OCP, or VSET, ISET, TMR pin short or open)	Blink at 1 Hz

7.3.4 Protection Features

The device closely monitors input and output voltages, as well as internal FET current and temperature for safe linear regulator operation.

7.3.4.1 Input Overvoltage Protection (VIN OVP)

If the voltage at the IN pin exceeds V_{IN_OV} , the device turns off, the safety timer suspends counting, and the device enters Standby mode. Once the IN voltage recovers to a normal level, the charge cycle and the safety timer automatically resume operation.

7.3.4.2 Output Overvoltage Protection (BAT OVP)

If the voltage at the OUT pin exceeds V_{OUT_OVP} , the device immediately stops charging, the safety timer suspends counting, and the device enters Standby mode. Once the OUT voltage recovers to a normal level, the charge cycle and the safety timer resume operation.

7.3.4.3 Output Overcurrent Protection (BAT OCP)

During normal operation, the OUT current should be regulated to the ISET programmed value. However, if a short circuit occurs on the ISET pin, the OUT current may rise to an unintended level. If the current at the OUT pin exceeds I_{OUT_OCP} , the device turns off after a deglitch, $t_{OUT_OCP_DGL}$, the safety timer resets the count, and the device remains latched off. An input supply or pin toggle is required to restart operation.

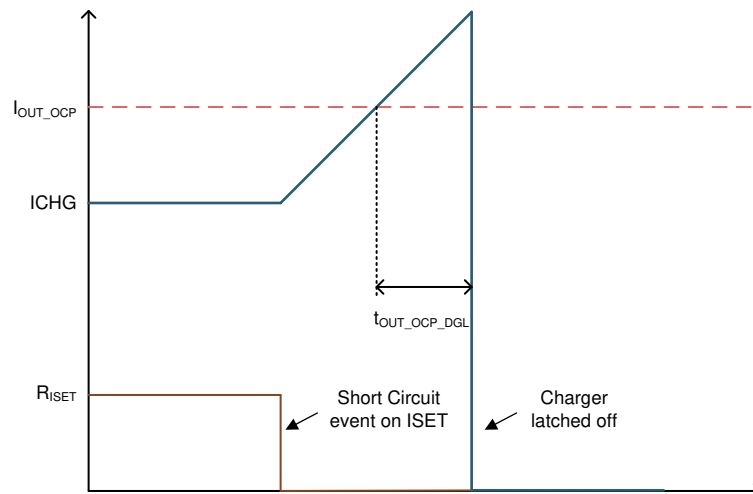


图 7-3. Overcurrent Protection

7.3.4.4 Thermal Regulation and Thermal Shutdown (TREG and TSHUT)

The device monitors its internal junction temperature (T_J) to avoid overheating and to limit the IC surface temperature. When the internal junction temperature exceeds the thermal regulation limit, the device automatically reduces the charge current to maintain the junction temperature at the thermal regulation limit (TREG). During thermal regulation, the safety timer runs at half the clock rate and the actual charging current is reduced below the programmed value on the ISET pin.

Additionally, the device has thermal shutdown to turn off the linear regulator when the IC junction temperature exceeds the TSHUT threshold. The charger resumes operation when the IC die temperature decreases below the TSHUT falling threshold.

7.4 Device Functional Modes

7.4.1 Shutdown or Undervoltage Lockout (UVLO)

The device is in the shutdown state if the IN pin voltage is less than V_{IN_LOWV} . The internal circuitry is powered down, all the pins are high impedance, and the device draws from the input supply. Once the IN voltage rises above the V_{IN_LOWV} threshold, the IC enters Sleep mode or Active mode depending on the OUT pin voltage.

7.4.2 Sleep Mode

The device is in Sleep mode when $V_{IN_LOWV} < V_{IN} < V_{OUT} + V_{SLEEPZ}$. The device waits for the input voltage to rise above $V_{OUT} + V_{SLEEPZ}$ to start operation.

7.4.3 Active Mode

The device is powered up and charges the battery when the TS pin is above V_{TS_ENZ} and the IN voltage ramps above both V_{IN_LOWV} and $V_{OUT} + V_{SLEEPZ}$. The device draws I_{Q_IN} from the supply to bias the internal circuitry. For details on the device power-up sequence, refer to [セクション 7.3.1](#).

7.4.3.1 Standby Mode

The device is in Standby mode if a valid input supply is present and charge is terminated or if a recoverable fault is detected. The internal circuitry is partially biased, and the device continues to monitor for either V_{OUT} to drop below V_{RECHG} or the recoverable fault to be removed.

7.4.4 Fault Mode

The fault conditions are categorized into recoverable and nonrecoverable as follows:

- Recoverable, from which the device should automatically recover once the fault condition is removed:
 - VIN OVP
 - BAT OVP
 - TS HOT
 - TS COLD
- Nonrecoverable, requiring pin or input supply toggle to resume operation:
 - BAT OCP
 - ISET pin short detected
 - Charge timer expires with V_{OUT} below V_{RECHG}

8 Application and Implementation

注

以下のアプリケーション情報は、TI の製品仕様に含まれるものではなく、TI ではその正確性または完全性を保証いたしません。個々の目的に対する製品の適合性については、お客様の責任で判断していただくことになります。お客様は自身の設計実装を検証しテストすることで、システムの機能を確認する必要があります。

8.1 Application Information

A typical application consists of the device configured as a standalone battery charger for a 1-cell to 6-cell NiMH battery. The charge voltage and number of cells is configured using a pull-down resistor on the VSET pin. The charge current is configured using a pull-down resistor on the ISET pin. A battery thermistor may be connected to the TS pin to allow the device to monitor battery temperature and control charging. Pulling the TS pin below V_{TS_ENZ} disables the charging function. The safety timer is programmable through a pull-down resistor on the TMR pin. Faults are indicated through the STAT pin.

8.2 Typical Applications

8.2.1 NiMH Charger Design Example

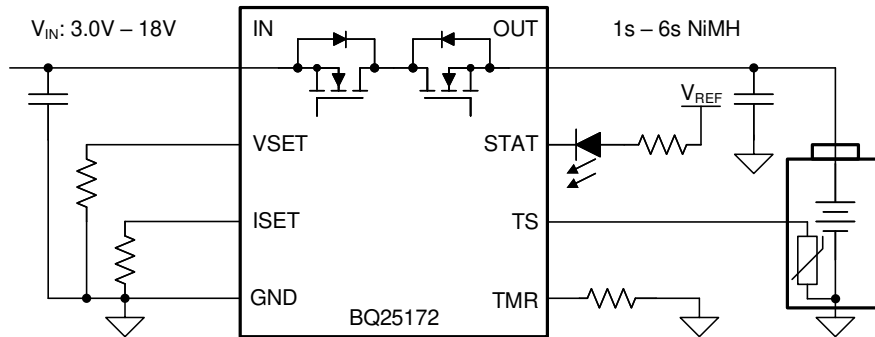


図 8-1. BQ25172 Simple Schematic

8.2.1.1 Design Requirements

The design requirements include the following:

- Input supply up to 18 V
- Battery: 4-cell NiMH, $R_{VSET} = 11 \text{ k}\Omega$
- Fast charge current: $I_{CHG} = 30 \text{ mA}$
- Recharge voltage for intermittent cycles: $V_{RECHG} = 1.33\text{V} \times 4 = 5.32 \text{ V}$
- Charge safety timer: $R_{TMR} = 8.2 \text{ k}\Omega$, $t_{SAFETY} = 16 \text{ hr}$
- TS – Battery temperature sense = 10-k Ω NTC (103AT-2)
- TS can be pulled low to disable charging

8.2.1.2 Detailed Design Procedure

The regulation voltage is set via the VSET pin to 2s NiMH, the input voltage is 5 V and the charge current is programmed via the ISET pin to 500 mA.

$$R_{ISET} = [K_{ISET} / I_{CHG}]$$

from electrical characteristics table. . . $K_{ISET} = 300 \text{ A}\Omega$

$$R_{ISET} = [300 \text{ A}\Omega / 0.5 \text{ A}] = 600 \Omega$$

Selecting the closest 1% resistor standard value, use a 604- Ω resistor between ISET and GND, for an expected I_{CHG} 497 mA.

8.2.1.3 Application Curves

$C_{IN} = 1 \mu\text{F}$, $C_{OUT} = 1 \mu\text{F}$, $V_{IN} = 5 \text{ V}$, $V_{OUT} = 3.8 \text{ V}$ (unless otherwise specified)



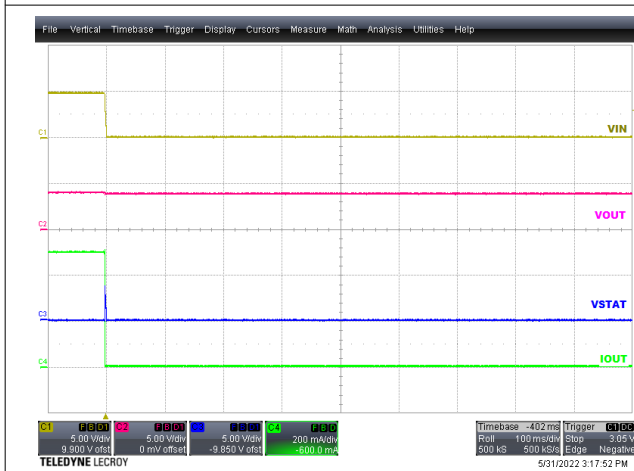
$R_{ISET} = 0.6\text{ k}\Omega$

8-2. Power Up with Battery



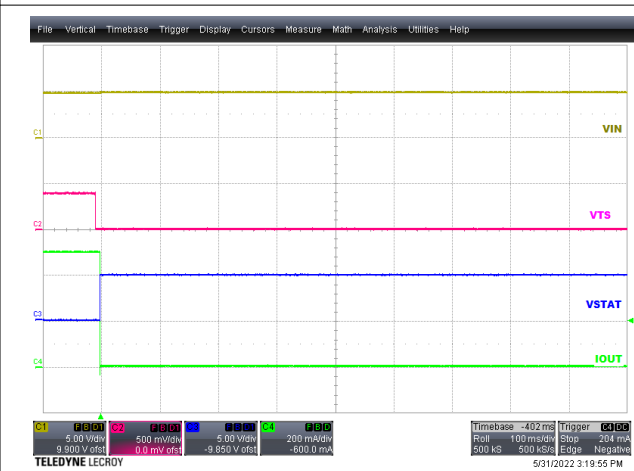
$R_{ISET} = 0.6\text{ k}\Omega$ OUT = open-circuit

8-3. Power Up without Battery



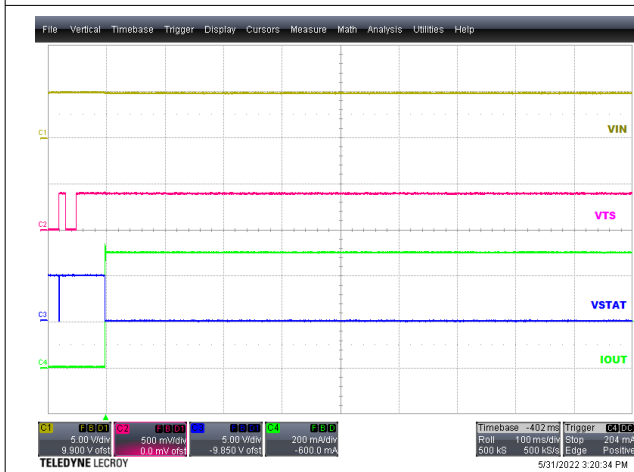
VIN = 5 V → 0 V

8-4. Power Down with Battery



TS pulled LOW

8-5. Charge Disable



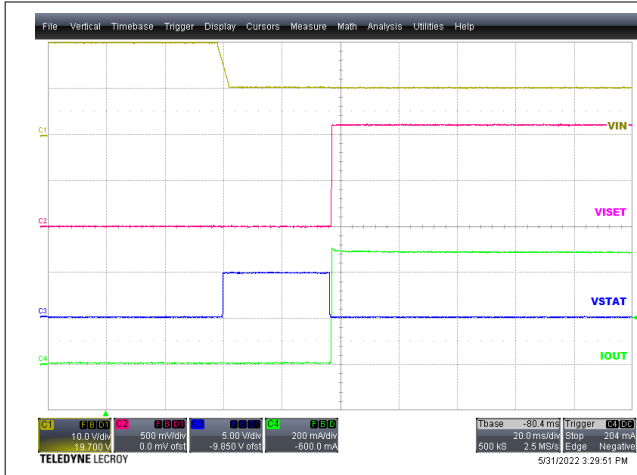
TS pin released

8-6. Charge Enable



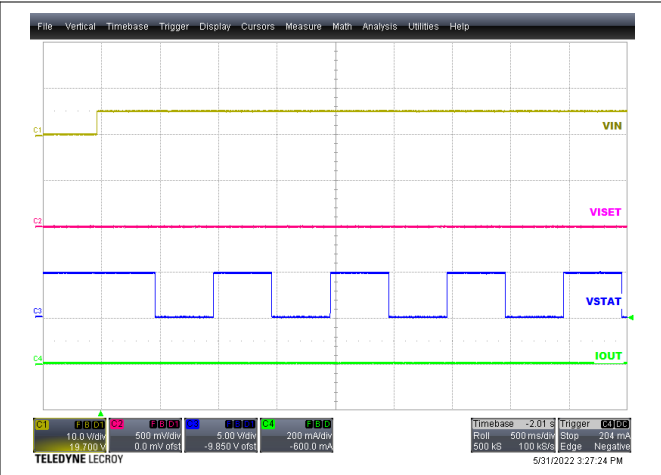
VIN = 5 V → 10 V

8-7. Input OVP Response



$V_{IN} = 20\text{ V} \rightarrow 10\text{ V}$

8-8. Input OVP Recovery



$I_{SET} = 0\ \Omega$

8-9. ISET Short-Circuit Then Power Up

9 Power Supply Recommendations

The device is designed to operate from an input voltage supply range between 3 V and 18 V (tolerant up to 30 V) and current capability of at least the maximum designed charge current. If located more than a few inches from the IN and GND pins, a larger capacitor is recommended.

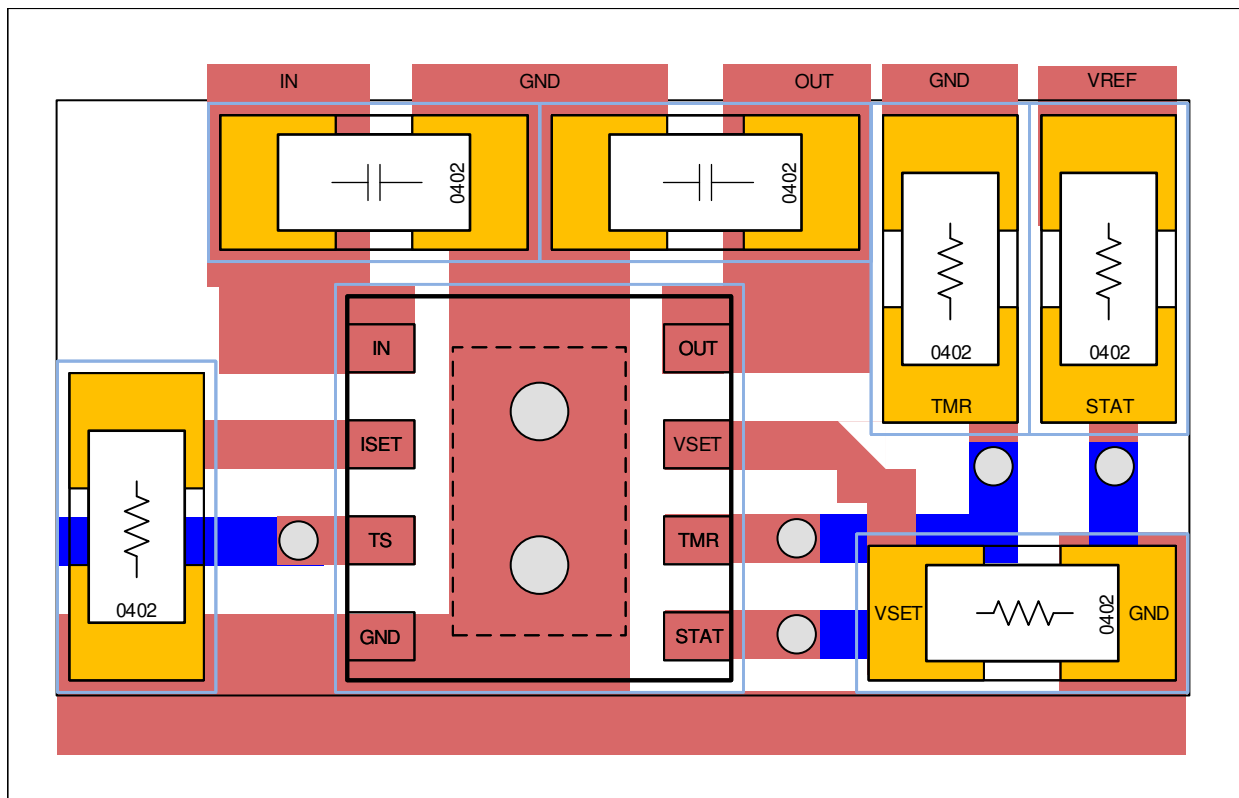
10 Layout

10.1 Layout Guidelines

To obtain optimal performance, the decoupling capacitor from the IN pin to the GND pin and the output filter capacitor from the OUT pin to the GND pin should be placed as close as possible to the device, with short trace runs to both IN, OUT, and GND.

- All low current GND connections should be kept separate from the high current charge or discharge paths from the battery. Use a single-point ground technique incorporating both the small signal ground path and the power ground path.
- The high current charge paths into the IN pin and from the OUT pin must be sized appropriately for the maximum charge current in order to avoid voltage drops in these traces.

10.2 Layout Example



☒ 10-1. BQ25172 Layout Example

11 Device and Documentation Support

11.1 Device Support

11.1.1 Third-Party Products Disclaimer

TI'S PUBLICATION OF INFORMATION REGARDING THIRD-PARTY PRODUCTS OR SERVICES DOES NOT CONSTITUTE AN ENDORSEMENT REGARDING THE SUITABILITY OF SUCH PRODUCTS OR SERVICES OR A WARRANTY, REPRESENTATION OR ENDORSEMENT OF SUCH PRODUCTS OR SERVICES, EITHER ALONE OR IN COMBINATION WITH ANY TI PRODUCT OR SERVICE.

11.2 Receiving Notification of Documentation Updates

To receive notification of documentation updates, navigate to the device product folder on [ti.com](https://www.ti.com). Click on *Subscribe to updates* to register and receive a weekly digest of any product information that has changed. For change details, review the revision history included in any revised document.

11.3 サポート・リソース

TI E2E™ サポート・フォーラムは、エンジニアが検証済みの回答と設計に関するヒントをエキスパートから迅速かつ直接得ることができる場所です。既存の回答を検索したり、独自の質問をしたりすることで、設計に必要な支援を迅速に得ることができます。

リンクされているコンテンツは、該当する貢献者により、現状のまま提供されるものです。これらは TI の仕様を構成するものではなく、必ずしも TI の見解を反映したものではありません。TI の [使用条件](#)を参照してください。

11.4 Trademarks

TI E2E™ is a trademark of Texas Instruments.

すべての商標は、それぞれの所有者に帰属します。

11.5 Electrostatic Discharge Caution



This integrated circuit can be damaged by ESD. Texas Instruments recommends that all integrated circuits be handled with appropriate precautions. Failure to observe proper handling and installation procedures can cause damage.

ESD damage can range from subtle performance degradation to complete device failure. Precision integrated circuits may be more susceptible to damage because very small parametric changes could cause the device not to meet its published specifications.

11.6 Glossary

[TI Glossary](#) This glossary lists and explains terms, acronyms, and definitions.

12 Mechanical, Packaging, and Orderable Information

The following pages include mechanical, packaging, and orderable information. This information is the most current data available for the designated devices. This data is subject to change without notice and revision of this document. For browser-based versions of this data sheet, refer to the left-hand navigation.

PACKAGING INFORMATION

Orderable Device	Status (1)	Package Type	Package Drawing	Pins	Package Qty	Eco Plan (2)	Lead finish/ Ball material (6)	MSL Peak Temp (3)	Op Temp (°C)	Device Marking (4/5)	Samples
BQ25172DSGR	ACTIVE	WSON	DSG	8	3000	RoHS & Green	NIPDAU	Level-1-260C-UNLIM	-40 to 125	B172	Samples

(1) The marketing status values are defined as follows:

ACTIVE: Product device recommended for new designs.

LIFEBUY: TI has announced that the device will be discontinued, and a lifetime-buy period is in effect.

NRND: Not recommended for new designs. Device is in production to support existing customers, but TI does not recommend using this part in a new design.

PREVIEW: Device has been announced but is not in production. Samples may or may not be available.

OBSELETE: TI has discontinued the production of the device.

(2) **RoHS:** TI defines "RoHS" to mean semiconductor products that are compliant with the current EU RoHS requirements for all 10 RoHS substances, including the requirement that RoHS substance do not exceed 0.1% by weight in homogeneous materials. Where designed to be soldered at high temperatures, "RoHS" products are suitable for use in specified lead-free processes. TI may reference these types of products as "Pb-Free".

RoHS Exempt: TI defines "RoHS Exempt" to mean products that contain lead but are compliant with EU RoHS pursuant to a specific EU RoHS exemption.

Green: TI defines "Green" to mean the content of Chlorine (Cl) and Bromine (Br) based flame retardants meet JS709B low halogen requirements of <=1000ppm threshold. Antimony trioxide based flame retardants must also meet the <=1000ppm threshold requirement.

(3) MSL, Peak Temp. - The Moisture Sensitivity Level rating according to the JEDEC industry standard classifications, and peak solder temperature.

(4) There may be additional marking, which relates to the logo, the lot trace code information, or the environmental category on the device.

(5) Multiple Device Markings will be inside parentheses. Only one Device Marking contained in parentheses and separated by a "-" will appear on a device. If a line is indented then it is a continuation of the previous line and the two combined represent the entire Device Marking for that device.

(6) Lead finish/Ball material - Orderable Devices may have multiple material finish options. Finish options are separated by a vertical ruled line. Lead finish/Ball material values may wrap to two lines if the finish value exceeds the maximum column width.

Important Information and Disclaimer:The information provided on this page represents TI's knowledge and belief as of the date that it is provided. TI bases its knowledge and belief on information provided by third parties, and makes no representation or warranty as to the accuracy of such information. Efforts are underway to better integrate information from third parties. TI has taken and continues to take reasonable steps to provide representative and accurate information but may not have conducted destructive testing or chemical analysis on incoming materials and chemicals. TI and TI suppliers consider certain information to be proprietary, and thus CAS numbers and other limited information may not be available for release.

In no event shall TI's liability arising out of such information exceed the total purchase price of the TI part(s) at issue in this document sold by TI to Customer on an annual basis.

GENERIC PACKAGE VIEW

DSG 8

WSON - 0.8 mm max height

2 x 2, 0.5 mm pitch

PLASTIC SMALL OUTLINE - NO LEAD

This image is a representation of the package family, actual package may vary.
Refer to the product data sheet for package details.



4224783/A

DSG0008A



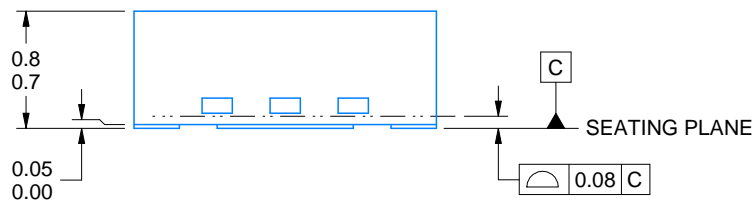
PACKAGE OUTLINE

WSON - 0.8 mm max height

PLASTIC SMALL OUTLINE - NO LEAD



ALTERNATIVE TERMINAL SHAPE TYPICAL



SIDE WALL METAL THICKNESS DIM A	
OPTION 1	OPTION 2
0.1	0.2



4218900/E 08/2022

NOTES:

1. All linear dimensions are in millimeters. Any dimensions in parenthesis are for reference only. Dimensioning and tolerancing per ASME Y14.5M.
2. This drawing is subject to change without notice.
3. The package thermal pad must be soldered to the printed circuit board for thermal and mechanical performance.

EXAMPLE BOARD LAYOUT

DSG0008A

WSON - 0.8 mm max height

PLASTIC SMALL OUTLINE - NO LEAD



LAND PATTERN EXAMPLE
SCALE:20X



SOLDER MASK DETAILS

4218900/E 08/2022

NOTES: (continued)

4. This package is designed to be soldered to a thermal pad on the board. For more information, see Texas Instruments literature number SLUA271 (www.ti.com/lit/slua271).
5. Vias are optional depending on application, refer to device data sheet. If any vias are implemented, refer to their locations shown on this view. It is recommended that vias under paste be filled, plugged or tented.

EXAMPLE STENCIL DESIGN

DSG0008A

WSON - 0.8 mm max height

PLASTIC SMALL OUTLINE - NO LEAD



SOLDER PASTE EXAMPLE
BASED ON 0.125 mm THICK STENCIL

EXPOSED PAD 9:
87% PRINTED SOLDER COVERAGE BY AREA UNDER PACKAGE
SCALE:25X

4218900/E 08/2022

NOTES: (continued)

6. Laser cutting apertures with trapezoidal walls and rounded corners may offer better paste release. IPC-7525 may have alternate design recommendations.

重要なお知らせと免責事項

TI は、技術データと信頼性データ (データシートを含みます)、設計リソース (リファレンス・デザインを含みます)、アプリケーションや設計に関する各種アドバイス、Web ツール、安全性情報、その他のリソースを、欠陥が存在する可能性のある「現状のまま」提供しており、商品性および特定目的に対する適合性の黙示保証、第三者の知的財産権の非侵害保証を含むいかなる保証も、明示的または黙示的にかかわらず拒否します。

これらのリソースは、TI 製品を使用する設計の経験を積んだ開発者への提供を意図したものです。(1) お客様のアプリケーションに適した TI 製品の選定、(2) お客様のアプリケーションの設計、検証、試験、(3) お客様のアプリケーションに該当する各種規格や、その他のあらゆる安全性、セキュリティ、規制、または他の要件への確実な適合に関する責任を、お客様のみが単独で負うものとし、

上記の各種リソースは、予告なく変更される可能性があります。これらのリソースは、リソースで説明されている TI 製品を使用するアプリケーションの開発の目的でのみ、TI はその使用をお客様に許諾します。これらのリソースに関して、他の目的で複製することや掲載することは禁止されています。TI や第三者の知的財産権のライセンスが付与されている訳ではありません。お客様は、これらのリソースを自身で使用した結果発生するあらゆる申し立て、損害、費用、損失、責任について、TI およびその代理人を完全に補償するものとし、TI は一切の責任を拒否します。

TI の製品は、[TI の販売条件](#)、または [ti.com](https://www.ti.com) やかかる TI 製品の関連資料などのいずれかを通じて提供する適用可能な条項の下で提供されています。TI がこれらのリソースを提供することは、適用される TI の保証または他の保証の放棄の拡大や変更を意味するものではありません。

お客様がいかなる追加条項または代替条項を提案した場合でも、TI はそれらに異議を唱え、拒否します。

郵送先住所 : Texas Instruments, Post Office Box 655303, Dallas, Texas 75265
Copyright © 2023, Texas Instruments Incorporated