

BQ298xyz シングルセル・リチウムイオン/リチウムポリマー・バッテリーの高速/フラッシュ充電用、ハイサイド NFET ドライバ内蔵の電圧/電流/温度プロテクタ

1 特長

- 電圧保護
 - 過電圧 (OV): $\pm 10\text{mV}$
 - 低電圧 (UV): $\pm 20\text{mV}$
- 電流保護:
 - 充電時の過電流 (OCC): $\pm 1\text{mV}$
 - 放電時の過電流 (OCD): $\pm 1\text{mV}$
 - 放電時の短絡 (SCD): $\pm 5\text{mV}$
- 温度保護
 - 過熱 (OT)
- その他の機能:
 - 最低 $1\text{m}\Omega$ の検知抵抗 (R_{SNS}) をサポート
 - ハイサイド保護
 - 高 V_{GS} FET ドライブ
 - 0V 充電 (BQ2980 のみ)
 - FET オーバーライド制御用の CTR ピンによりシステムリセット/シャットダウンを実現
 - 外付け PTC サーミスタを使った第 2 の OT 保護を目的として CTR を構成可能
- 消費電流:
 - 通常モード: $4\mu\text{A}$
 - シャットダウンモード: $0.1\mu\text{A}$ 以下
- パッケージ:
 - 8pin X2QFN: $1.50 \times 1.50 \times 0.37\text{mm}$

2 アプリケーション

- スマートフォン
- タブレット
- パワーバンク
- ウェアラブル

3 概要

BQ298xyz ファミリーは、内蔵のチャージポンプ FET ドライバによって、1 シリーズ リチウムイオン/リチウムポリマーバッテリーの使用時にハイサイドの 1 次バッテリーセルを保護し、セル電圧範囲全体で安定した R_{dson} を実現できます。システムの熱性能の向上に向けて、高精度な BQ298x では最小 $1\text{m}\Omega$ の検知抵抗を使用できます。

またホスト制御により FET ドライバをオーバーライドするように CTR ピンを構成し、システムリセットまたはシャットダウン機能を実装することも可能です。あるいは、内蔵されているダイ温度センサに加えて、外付けの正温度係数 (PTC) サーミスタに接続するように CTR ピンを構成し、FET OT 保護を実現することもできます。BQ2980xy デバイスはゼロボルト (0V) 充電をサポートしていますが、BQ2982xy デバイスはこの機能を無効にしています。

製品情報

部品番号 (1)	パッケージ	本体サイズ (公称)
BQ2980xy	X2QFN	$1.50\text{mm} \times 1.50\text{mm} \times 0.37\text{mm}$
BQ2982xy	X2QFN	$1.50\text{mm} \times 1.50\text{mm} \times 0.37\text{mm}$

(1) 利用可能なすべてのパッケージについては、注文情報および [デバイスの比較表](#) を参照してください。

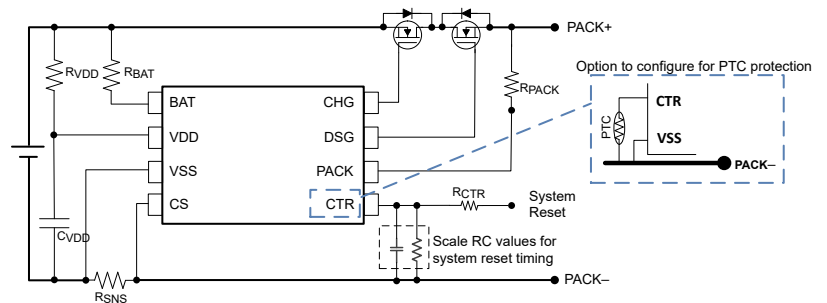

概略回路図



Table of Contents

1 特長	1	8 Application and Implementation	14
2 アプリケーション	1	8.1 Application Information.....	14
3 概要	1	8.2 Typical Applications.....	17
4 Device Comparison Table	3	9 Power Supply Recommendations	20
5 Pin Configuration and Functions	3	10 Layout	20
6 Specifications	4	10.1 Layout Guidelines.....	20
6.1 Absolute Maximum Ratings.....	4	10.2 Layout Example.....	21
6.2 ESD Ratings.....	4	11 Device and Documentation Support	22
6.3 Recommended Operating Conditions.....	4	11.1 サード・パーティ製品に関する免責事項.....	22
6.4 Thermal Information.....	4	11.2 ドキュメントの更新通知を受け取る方法.....	22
6.5 Electrical Characteristics.....	5	11.3 サポート・リソース.....	22
6.6 Typical Characteristics.....	8	11.4 Trademarks.....	22
7 Detailed Description	9	11.5 静電気放電に関する注意事項.....	22
7.1 Overview.....	9	11.6 用語集.....	22
7.2 Functional Block Diagram.....	10	12 Revision History	23
7.3 Feature Description.....	10	13 Mechanical, Packaging, and Orderable Information	24
7.4 Device Functional Modes.....	13		

4 Device Comparison Table

BQ298xyz Device Family (BQ2980xy with ZVCHG [0-V Charging] Enabled, BQ2982xy with ZVCHG Disabled)													
PART NUMBER	OVP (V)	OVP DELAY (s)	UVP (V)	UVP DELAY (ms)	OCC (mV)	OCC DELAY (ms)	OCD (mV)	OCD DELAY (ms)	SCD (mV)	SCD DELAY (μs)	OT (°C)	CTR/ PTC Config	UV_Shut
BQ298000	4.475	1.25	2.600	144	-8	8	8	8	20	250 Fixed	85	CTR	Enabled
BQ298006	4.475	1.00	2.500	20	-12	16	14	16	40	250 Fixed	75	CTR	Enabled
BQ298009	4.500	1.00	2.900	20	-18	8	30	16	40	250 Fixed	Disable	CTR	Enabled
BQ298010	4.500	1.00	2.900	20	-10	8	20	16	30	250 Fixed	Disable	CTR	Enabled
BQ298012	4.300	1.00	2.750	144	-4	8	14	20	30	250 Fixed	Disable	CTR	Enabled
BQ298015	4.440	1.25	2.800	144	-8	8	8	8	20	250 Fixed	85	CTR	Enabled
BQ298018	4.400	1.00	2.700	144	-8	8	20	48	60	250 Fixed	85	CTR	Enabled
BQ298019	4.425	1.25	2.800	144	-30	48	8	48	40	250 Fixed	85	CTR	Enabled
BQ298215	4.440	1.25	2.800	144	-8	8	8	8	20	250 Fixed	85	CTR	Enabled
BQ298216	4.300	1.00	2.500	144	-4	8	14	20	30	250 Fixed	Disabled	CTR	Enabled
BQ298217	4.250	1.25	2.600	125	-36	8	60	16	200	250 Fixed	Disabled	CTR	Enabled
BQ298218	4.200	1.25	2.500	125	-18	20	40	20	120	250 Fixed	75	PTC 5MΩ Pullup Enabled	Enabled

5 Pin Configuration and Functions



図 5-1. RUG Package 8-Pin X2QFN Top View

表 5-1. Pin Functions

NUMBER	NAME	TYPE	DESCRIPTION
1	BAT	I ⁽¹⁾	BAT voltage sensing input (connected to the battery side)
2	VDD	P	Supply voltage
3	VSS	—	Device ground
4	CS	I	Current sensing input (connect to PACK- side of the sense resistor)
5	CTR	I	Active high control pin to open FET drivers and shut down the device. It can be configured to enable an internal pull-up and connect the CTR pin to an external PTC for OT protection.
6	PACK	I	Pack voltage sensing pin (connected to the charger side, typically referred to as PACK+ and PACK-)
7	DSG	O	DSG FET driver
8	CHG	O	CHG FET driver

(1) I = input, O = output, P = power

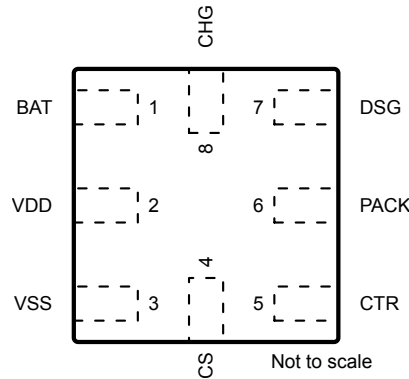
6 Specifications

6.1 Absolute Maximum Ratings

over operating free-air temperature range (unless otherwise noted)⁽¹⁾

		MIN	MAX	UNIT
Supply voltage	VDD	-0.3	6	V
Input voltage	PACK	-0.3	24	V
	BAT	-0.3	6	
	CS	-0.3	0.3	
	CTR	-0.3	5	
Output voltage	CHG	-0.3	20	V
	DSG	-0.3	20	
Storage temperature, T _{stg}		-55	150	°C

- (1) Operation outside the Absolute Maximum Ratings may cause permanent device damage. Absolute Maximum Ratings do not imply functional operation of the device at these or any other conditions beyond those listed under Recommended Operating Conditions. If outside the Recommended Operating Conditions but within the Absolute Maximum Ratings, the device may not be fully functional, and this may affect device reliability, functionality, performance, and shorten the device lifetime.

6.2 ESD Ratings

		VALUE	UNIT
V _(ESD) Electrostatic discharge	Human-body model (HBM), per ANSI/ESDA/JEDEC JS-001 ⁽¹⁾	±1000	V
	Charged-device model (CDM), per JEDEC specification JESD22-C101 ⁽²⁾	±250	

- (1) JEDEC document JEP155 states that 500-V HBM allows safe manufacturing with a standard ESD control process.
(2) JEDEC document JEP157 states that 250-V CDM allows safe manufacturing with a standard ESD control process.

6.3 Recommended Operating Conditions

over operating free-air temperature range (unless otherwise noted)

		MIN	MAX	UNIT
Supply voltage	VDD	1.5	5.5	V
Input voltage	PACK	0	20	V
	BAT	1.5	5.5	
	CS	-0.25	0.25	
	CTR	0	5	
Output voltage	CHG	V _{SS}	VDD + VDD × A _{FETON}	V
	DSG	V _{SS}	VDD + VDD × A _{FETON}	
Operating temperature, T _A		-40	85	°C

6.4 Thermal Information

THERMAL METRIC ⁽¹⁾		BQ2980xy/BQ2982xy	UNIT
		RUG (X2QFN)	
		8 PINS	
R _{θJA}	Junction-to-ambient thermal resistance	171.8	°C/W
R _{θJC(top)}	Junction-to-case (top) thermal resistance	75	°C/W
R _{θJB}	Junction-to-board thermal resistance	94.7	°C/W
ψ _{JT}	Junction-to-top characterization parameter	2.5	°C/W
ψ _{JB}	Junction-to-board characterization parameter	94.9	°C/W

- (1) For more information about traditional and new thermal metrics, see the [Semiconductor and IC Package Thermal Metrics](#) application report.

6.5 Electrical Characteristics

Typical values stated at $T_A = 25^\circ\text{C}$ and $V_{DD} = 3.6\text{ V}$. MIN/MAX values stated with $T_A = -40^\circ\text{C}$ to $+85^\circ\text{C}$ and $V_{DD} = 3$ to 5 V unless otherwise noted.

PARAMETER		TEST CONDITIONS	MIN	TYP	MAX	UNIT
SUPPLY CURRENT CONSUMPTION						
I_{NORMAL}	Normal mode supply current	V_{CHG} and $V_{\text{DSG}} > 5\text{ V}$, $C_{\text{LOAD}} = 8\text{ nF}$ (typical $20\text{ nA}^{(1)}$), $V_{\text{DD}} > 4.0\text{ V}$		5	8	μA
		V_{CHG} and $V_{\text{DSG}} > 5\text{ V}$, $C_{\text{LOAD}} = 8\text{ nF}$ (typical $20\text{ nA}^{(1)}$), $UVP < V_{\text{DD}} < 3.9\text{ V}$		4	6	μA
I_{FETOFF}	Supply current with both FET drivers off	$V_{\text{CHG}} = V_{\text{DSG}} \leq 0.2\text{ V}$		2	4	μA
I_{SHUT}	Shutdown current	$V_{\text{PACK}} < V_{\text{BAT}}$, $V_{\text{DD}} = 1.5\text{ V}$			0.1	μA
N-CH FET DRIVER, CHG and DSG						
A_{FETON}	FET driver gain factor, the V_{gs} voltage to FET	V_{CHG} or $V_{\text{DSG}} = V_{\text{DD}} + V_{\text{DD}} \times A_{\text{FETON}}$ $UVP < V_{\text{DD}} < 3.9\text{ V}$ $C_{\text{LOAD}} = 8\text{ nF}$	1.65	1.75	1.81	V/V
		V_{CHG} or $V_{\text{DSG}} = V_{\text{DD}} + V_{\text{DD}} \times A_{\text{FETON}}$ $V_{\text{DD}} > 4.0\text{ V}$ $C_{\text{LOAD}} = 8\text{ nF}$	1.45	1.55	1.68	V/V
V_{FETOFF}	FET driver off output voltage	$V_{\text{FETOFF}} = V_{\text{CHG}} - V_{\text{SS}}$ or $V_{\text{DSG}} - V_{\text{SS}}$ $C_{\text{LOAD}} = 8\text{ nF}$			0.2	V
$V_{\text{DRIVER_SHUT}}$	FET driver charge pump shut down voltage	Charge pump enabled when V_{DD} rises to $V_{\text{DRIVER_SHUT}}$	1.95	2	2.1	V
$V_{\text{DRIVER_SHUT_HYS}}$	FET driver charge pump shut down voltage hysteresis	Charge pump disabled when V_{DD} falls to $V_{\text{DRIVER_SHUT}} - V_{\text{DRIVER_SHUT_HYS}}$		50		mV
$t_{\text{rise}}^{(2)}$	FET driver rise time	$C_{\text{LOAD}} = 8\text{ nF}$, V_{CHG} or V_{DSG} rises from V_{DD} to $(2 \times V_{\text{DD}})$		400	800	μs
t_{fall}	FET driver fall time	$C_{\text{LOAD}} = 8\text{ nF}$, V_{CHG} or V_{DSG} fall to V_{FETOFF}		50	200	μs
I_{LOAD}	FET driver maximum loading				10	μA
VOLTAGE PROTECTION						
V_{OVP}	Overvoltage detection range	Factory configured, 50-mV step	3750		5200	mV
$V_{\text{OVP_ACC}}$	Overvoltage detection accuracy	$T_A = 25^\circ\text{C}$, CHG/DSG $C_{\text{LOAD}} < 1\text{ }\mu\text{A}$	-10		10	mV
		$T_A = 0^\circ\text{C}$ to 60°C , CHG/DSG $C_{\text{LOAD}} < 1\text{ }\mu\text{A}$	-15		15	
		$T_A = -40^\circ\text{C}$ to $+85^\circ\text{C}$, CHG/DSG $C_{\text{LOAD}} < 1\text{ }\mu\text{A}$	-25		25	
$V_{\text{OVP_HYS}}$	Overvoltage release hysteresis voltage	Fixed at 200 mV	150	200	250	mV
V_{UVP}	Undervoltage detection range	Factory configured, 50-mV step	2200		3000	mV
$V_{\text{UVP_ACC}}$	Undervoltage detection accuracy	$T_A = 25^\circ\text{C}$	-20		20	mV
		$T_A = 0^\circ\text{C}$ to 60°C	-30		30	
		$T_A = -40^\circ\text{C}$ to $+85^\circ\text{C}$	-50		50	
$V_{\text{UVP_HYS}}$	Undervoltage release hysteresis voltage	Fixed at 200 mV	150	200	250	mV
$R_{\text{PACK-VSS}}$	Resistance between PACK and VSS during UV fault		100	300	550	k Ω
CURRENT PROTECTION						
V_{OC}	Overcurrent in charge (OCC) and discharge (OCD) range	Factory configured, 2-mV step. For OCC, the range is negative (min = -64, max = -4).	4		64	mV

6.5 Electrical Characteristics (続き)

Typical values stated at $T_A = 25^\circ\text{C}$ and $V_{DD} = 3.6\text{ V}$. MIN/MAX values stated with $T_A = -40^\circ\text{C}$ to $+85^\circ\text{C}$ and $V_{DD} = 3$ to 5 V unless otherwise noted.

PARAMETER		TEST CONDITIONS	MIN	TYP	MAX	UNIT	
V_{SCD}	Short circuit in discharge threshold	Factory configured		10		mV	
				20			
				30			
				40			
				60			
				120			
				200			
V_{OC_ACC}	Overcurrent (OCC, OCD1, OCD2, SCD) detection accuracy	< 20 mV	-1		1	mV	
		20 to approximately 55 mV	-3	2	3		
		56 to approximately 100 mV	-5		5		
		> 100 mV	-12		12		
$I_{PACK-VDD}$	Current sink between PACK and VDD during current fault. Used for load removal detection		8		24	μA	
I_{OCD_REC}	OCD, SCD recovery detection current	Sum of current from VDD and BAT during OCD or SCD fault			55	μA	
V_{OC_REL}	OCC fault release threshold	$(V_{BAT} - V_{PACK})$		100		mV	
	OCD, SCD fault release threshold	$(V_{PACK} - V_{BAT})$		-400		mV	
OVERTEMPERATURE PROTECTION⁽²⁾							
T_{OT}	Internal overtemperature threshold	Factory configured		75		$^\circ\text{C}$	
				85			
T_{OT_ACC}	Internal overtemperature detection accuracy		-10		10	$^\circ\text{C}$	
T_{OT_HYS}	Internal overtemperature hysteresis		8	15	22	$^\circ\text{C}$	
PROTECTION DELAY⁽²⁾							
t_{OVP}	Overvoltage detection delay	Factory configured		0.2	0.25	0.3	s
				0.8	1	1.2	
				1	1.25	1.5	
				3.6	4.5	5.4	
t_{UVP}	Undervoltage detection delay	Factory configured		16	20	24	ms
				76.8	96	115.2	
				100	125	150	
				115.2	144	172.8	
t_{OC}	Overcurrent (OCC, OCD) detection delay	Factory configured		5.6	8	10.5	ms
				12.4	16	19.6	
				16	20	24	
				38.4	48	57.6	
t_{SCD}	Short circuit discharge detection delay	Fixed configuration	125	250	375	μs	
t_{OT}	Overtemperature detection delay	Fixed configuration	3.6	4.5	5.4	s	
FET OVERRIDE/DEVICE SHUTDOWN CONTROL, CTR							
V_{IH}	High-level input		1			V	

6.5 Electrical Characteristics (続き)

Typical values stated at $T_A = 25^\circ\text{C}$ and $V_{DD} = 3.6\text{ V}$. MIN/MAX values stated with $T_A = -40^\circ\text{C}$ to $+85^\circ\text{C}$ and $V_{DD} = 3$ to 5 V unless otherwise noted.

PARAMETER	TEST CONDITIONS	MIN	TYP	MAX	UNIT
V_{IL}	Low-level input			0.4	V
V_{HYS}	Hysteresis for V_{IH} and V_{IL}	200			mV
R_{PULL_UP}	Effective Internal pull-up resistance (to use with external PTC)	Factory configured if enabled		1.5	M Ω
			5		
			8		
ZVCHG (0-V Charging)					
V_{0CHGR}	Charger voltage requires to start 0-V charging	BQ2980xy only (ZVCHG is disabled in BQ2982xy). The CHG driver becomes high impedance when $V_{DD} < V_{0INH}$.		2	V
V_{0INH}	Battery voltage that inhibits 0-V charging			1	V

- (1) I_{NORMAL} is impacted by the efficiency of the charge pump driving the CHG and DSG FETs. An ultra-low-gate-leakage FET may be required. I_{NORMAL} can be significantly higher with FETs with typical I_{GSS} values of $10\ \mu\text{A}$. See [Selection of Power FET](#) for more details.
- (2) Specified by design.

6.6 Typical Characteristics

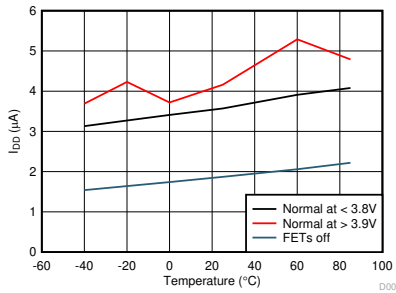

6-1. Normal and FET Off Current Across Temperature

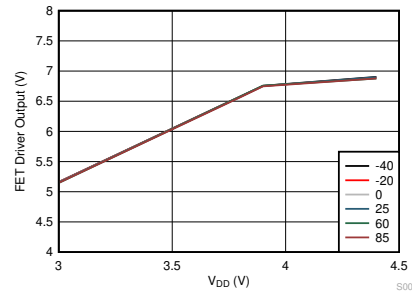

6-2. CHG and DSG Output (Loading with an 8-nF Capacitor on CHG and DSG) Across VDD

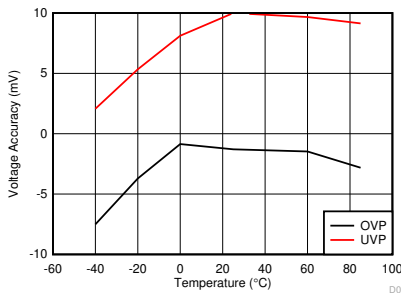

6-3. Overvoltage and Undervoltage Accuracy Across Temperature

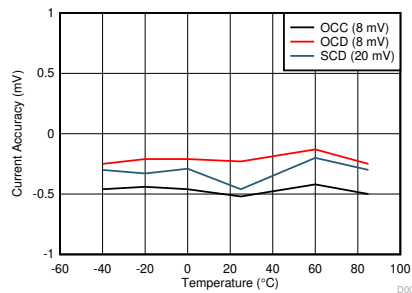

6-4. Overcurrent Accuracy Across Temperature

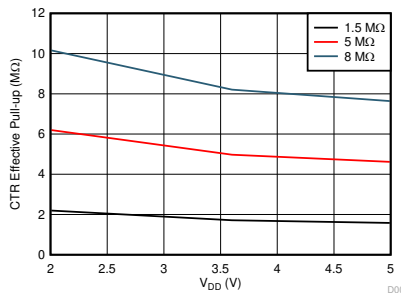

6-5. CTR Internal Pull-Up Resistor (if Configured) Across VDD

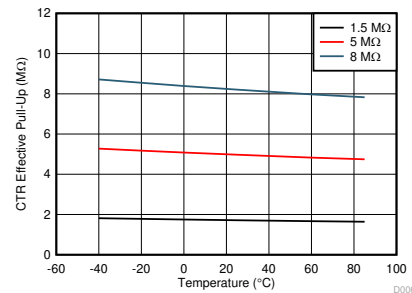

6-6. CTR Internal Pull-Up Resistor (if Configured) Across Temperature (VDD at 3.6 V)

7 Detailed Description

7.1 Overview

The BQ298xyz devices are high-side single-cell protectors designed to improve thermal performance by reducing power dissipation across the protection FETs. This is achieved with high-side protection with a built-in charge pump to provide higher V_{GS} to the FET gate voltage to reduce FET $R_{DS(on)}$. Additionally, the device supports as low as a 1-m Ω sense resistor with ± 1 -mV accuracy, resulting in lower heat dissipation at the sense resistor without compromising current accuracy.

The BQ298x device implements a CTR pin that allows external control to open the power FETs, as well as shut down the device for low power storage. Optionally, the CTR pin can be configured to connect to a PTC and be used for overtemperature protection.

7.1.1 Device Configurability

表 7-1 provides guidance on possible configurations of the BQ2980 and BQ2982 devices.

注

Texas Instruments preprograms devices: Devices are not intended to be further customized by the customer.

表 7-1. Device Configuration Range

FAULT		RANGE	STEP SIZE	UNIT	DELAY SELECTION	CHG, DSG STATUS	RECOVERY DESCRIPTION (Non-Configurable)
OV	Overvoltage	3750 – 5200	50	mV	0.25, 1, 1.25, 4.5 s	CHG OFF	(200-mV hysteresis AND charger removal) OR (below OV threshold AND discharge load is detected)
UV	Undervoltage	2200 – 3000	50	mV	20, 96, 125, 144 ms	Option 1: UV_SHUT enable The device goes into SHUTDOWN.	(200-mV hysteresis AND discharge load is removed before device shuts down) OR (above UV threshold AND charger connection)
						Option 2: UV_SHUT disable DSG off, power consumption drops to I_{FETOFF} , and the device does not shut down.	(200-mV hysteresis) OR (above UV threshold AND charger connection)
OCC	Overcurrent in Charge	–64 – –4	2	mV	8, 16, 20, 48 ms	CHG OFF	Detect a charger removal ($V_{BAT} - V_{PACK}$) > 100-mV typical
OCD	Overcurrent in Discharge	4 – 64	2	mV		DSG OFF	Detect a discharge load removal ($V_{BAT} - V_{PACK}$) < 400-mV typical
SCD	Short circuit in discharge	10, 20, 30, 40, 60, 120, 200	—	mV	Fixed 250 μ s		
OT	Overtemperature (through internal temperature sensor)	75, 85	—	°C	Fixed 4.5 s	CHG and DSG OFF	Fixed 15°C hysteresis
OT (PTC)	Internal pull-up resistor for OT with PTC (through external PTC on CTR pin)	1.5, 5, 8	—	M Ω	—	CHG and DSG OFF	Voltage on CTR pin drops below CTR V_{IL} level

7.2 Functional Block Diagram

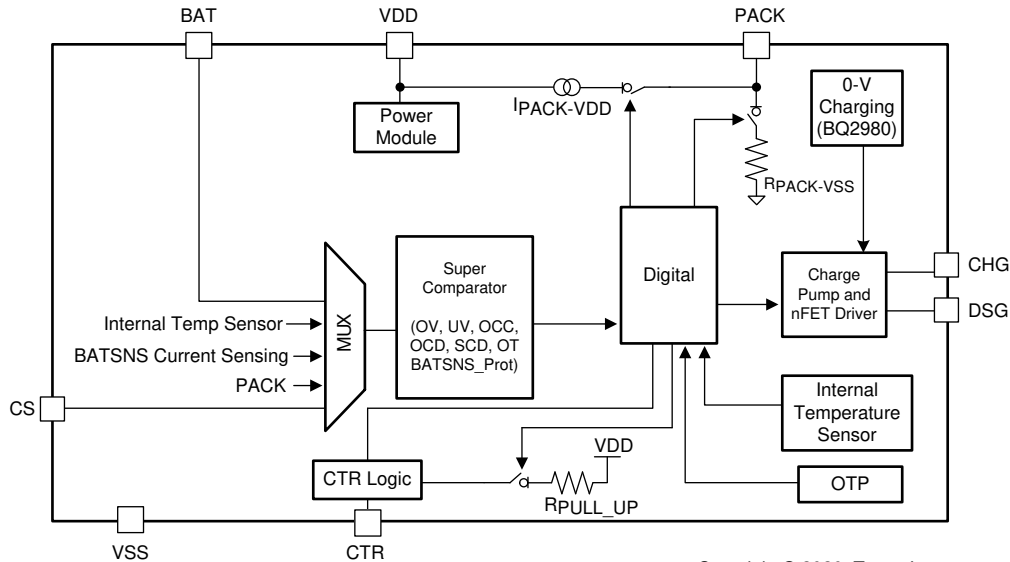

Copyright © 2020, Texas Instruments Incorporated

7.3 Feature Description

7.3.1 Overvoltage (OV) Status

The device detects an OV fault when $V_{BAT} > V_{OVP}$ (OV threshold) during charging. If this condition exists for longer than the OV delay (t_{OVP}), the CHG output is driven to V_{FETOFF} to turn off the CHG FET.

The OV status is released and the CHG output rises to HIGH, that is, $V_{CHG} = VDD \times (1 + A_{FETON})$, if one of the following conditions occurs:

- When V_{BAT} is $< (V_{OVP} - V_{OVP_HYS})$ and the charger is removed or
- When V_{BAT} is $< V_{OVP}$ and a discharge load is detected.

The device detects the charger is removed if $(V_{PACK} - V_{BAT}) < 100\text{-mV}$ typical. To detect if a load is attached, the device checks if $(V_{BAT} - V_{PACK}) > 400\text{-mV}$ typical.

7.3.2 Undervoltage (UV) Status

The device detects a UV fault when the battery voltage measured is below the UV threshold (V_{UVP}). If this condition exists for longer than the UV delay (t_{UVP}), the DSG output is driven to V_{FETOFF} to turn off the DSG FET.

The device includes a UV_SHUT option which may be enabled during factory configuration. If this option is enabled, during the UV fault state the device goes into SHUTDOWN mode to preserve the battery. In SHUTDOWN mode, the BQ2980 will drive the CHG output to the PACK voltage, putting the device into ZVCHG mode (the BQ2982 does not enable this ZVCHG mode). That means, the CHG FET can be turned on if a charger is connected and both VDD and PACK meet the ZVCHG turn-on conditions (see [セクション 7.3.9](#) for more details). The PACK pin is internally pulled to VSS through $R_{PACK-VSS}$. This is to determine if the charger is disconnected on the PACK+ terminal before shutting down the device. It is also to ensure the device does not falsely wake up from SHUTDOWN mode due to noise.

The UV status is released and the DSG output rises to HIGH, that is, $V_{DSG} = VDD \times (1 + A_{FETON})$, if one of the following conditions occurs:

- When V_{BAT} is $> (V_{UVP} + V_{UVP_HYS})$ and the discharge load is removed or
- When V_{BAT} is $> V_{UVP}$ and a charger is connected.

The device detects that the charger is attached if $(V_{PACK} - V_{BAT}) > 700\text{-mV}$ typical. To detect for load removal, the device checks if $(V_{BAT} - V_{PACK}) < 400\text{-mV}$ typical.

If the UV_SHUT option is disabled, during a UV fault DSG is turned off and the device does not go into SHUTDOWN. The power consumption is reduced to I_{FETOFF} . The PACK pin is still internally pulled to VSS through $R_{PACK-VSS}$. To recover UV with this option, one of the following conditions must occur:

- When V_{BAT} is $> (V_{UVP} + V_{UVP_HYS})$ or
- When V_{BAT} is $> V_{UVP}$ and a charger is connected.

7.3.3 Overcurrent in Charge (OCC) Status

The BQ298xyz device detects a current fault by monitoring the voltage drop across an external sense resistor (R_{SNS}) between the CS and VSS pins. The device detects an OCC fault when $(V_{CS} - VSS) < OCC$ threshold ($-V_{OC}$). If this condition exists for longer than the OCC delay (t_{OC}), the CHG output is driven to V_{FETOFF} to turn off the CHG FET.

The OCC status is released and the CHG output rises to HIGH, that is $V_{CHG} = VDD \times (1 + A_{FETON})$, if $(V_{BAT} - V_{PACK}) > 100$ mV, indicating a charger is removed.

7.3.4 Overcurrent in Discharge (OCD) and Short Circuit in Discharge (SCD) Status

The BQ298xyz device detects a current fault by monitoring the voltage drop across an external sense resistor (R_{SNS}) between the CS and VSS pins. The device applies the same method to detect OCD and SCD faults and applies the same recovery scheme to release the OCD and SCD faults.

The device detects an OCD fault when $(V_{CS} - VSS) > OCD$ threshold ($+V_{OC}$). If this condition exists for longer than the OCD delay (t_{OC}), the DSG output is driven to V_{FETOFF} to turn off the DSG FET. The SCD detection is similar to OCD, but uses the SCD threshold (V_{SCD}) and SCD delay (t_{SCD}) time.

During an OCD or SCD state, the device turns on the recovery detection circuit. An internal current sink ($I_{PACK-VDD}$) is connected between the PACK and VDD pins, and the device consumes I_{OC_REC} during the OCD and SCD fault until recovery is detected.

The OCD or SCD status is released and the DSG output rises to HIGH, that is $V_{DSG} = VDD \times (1 + A_{FETON})$, if $(V_{BAT} - V_{PACK}) < 400$ mV, indicating a discharge load is removed.

7.3.5 Overtemperature (OT) Status

The device has a built-in internal temperature sensor for OT protection. The sensor detects OT when the internal temperature measurement is above the internal overtemperature threshold (T_{OT}). If this condition exists for longer than the OT delay (t_{OT}), both CHG and DSG outputs are driven to V_{FETOFF} to turn off the CHG and DSG FETs.

The OT state is released and the CHG and DSG outputs rise to HIGH, that is V_{CHG} and $V_{DSG} = VDD \times (1 + A_{FETON})$, if the internal temperature measurement falls below $(T_{OT} - T_{OT_HYS})$.

7.3.6 Charge and Discharge Driver

The device has a built-in charge pump to support high-side protection using an NFET. When the drivers are on, the CHG and DSG pins are driven to the $VDD \times (1 + A_{FETON})$ voltage level. This means the V_{gs} across the CHG or DSG FET is about $(VDD \times A_{FETON})$. When the drivers are turned off and $VDD \geq V_{0INH}$, the CHG and/or DSG output is driven to V_{FETOFF} .

The charge pump requires $VDD > V_{DRIVER_SHUT}$ to operate. When VDD falls below $V_{DRIVER_SHUT} - V_{DRIVER_SHUT_HYS}$, the DSG output is off. The CHG output can be turned on in BQ2980 if the ZVCHG charging condition is met. See [セクション 7.3.9](#) for more details.

7.3.7 CTR for FET Override and Device Shutdown

The CTR pin is an active-high input pin, which can be controlled by the host system to turn off both CHG and DSG outputs momentarily to reset the system, shut down the system for low-power storage, or as a necessary shutdown if the host detects a critical system error.

The CTR pin uses a 4.5-s timer (same specification tolerance as the t_{OVP} delay 4.5-s option) to differentiate a reset and shutdown signal. CHG and DSG are off when $V_{CTR} > CTR V_{IH}$ for > 200 μ s. Counting from the start of

$V_{CTR} > V_{IH}$, if V_{CTR} drops below V_{IL} within 3.6 s, CHG and DSG simply turn back on. If CTR remains HIGH for > 5.4 s, the device enters SHUTDOWN mode.

With this timing control, the system designer can use an RC circuit to implement either a host-controlled power-on-reset or a system shutdown.



図 7-1. CTR Level in Rising and Falling Direction

注

- CTR shuts down the device only when V_{CTR} is HIGH for > 5.4 s AND when there is no OV or OT fault present.
- The CTR V_{IH} level is the voltage level at which the CTR pin is considered HIGH in the positive direction as voltage increases. There is a minimum hysteresis designed into the logic level; therefore, as voltage decreases, CTR is considered HIGH at the $(V_{IH} - V_{HYS})$ level.
- The FET override and the shutdown functions are not available if the CTR pull-up is enabled. See [セクション 7.3.8](#) for details.

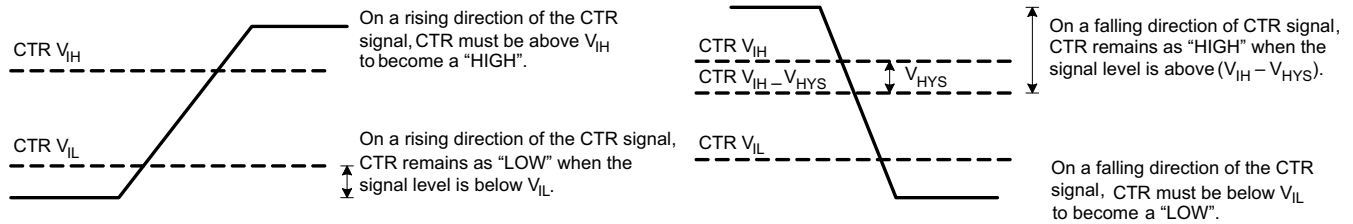

図 7-2. System Reset Function Implementation



図 7-3. Potential System- Controlled Shutdown Implementation

7.3.8 CTR for PTC Connection

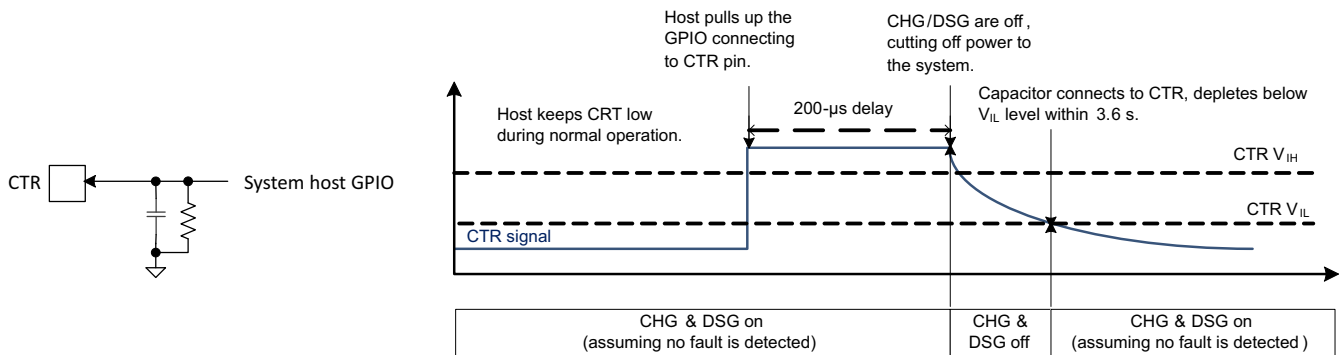
If any of the CTR pull-up resistors are selected, the device assumes a PTC is connected to the CTR pin. There are three internal pull-up options: 1.5 MΩ, 5 MΩ, or 8 MΩ. The internal pull-up allows a PTC to be connected

between the CTR pin and VSS. This turns the CTR pin to detect an overtemperature fault through an external PTC, as shown in [Figure 7-4](#).

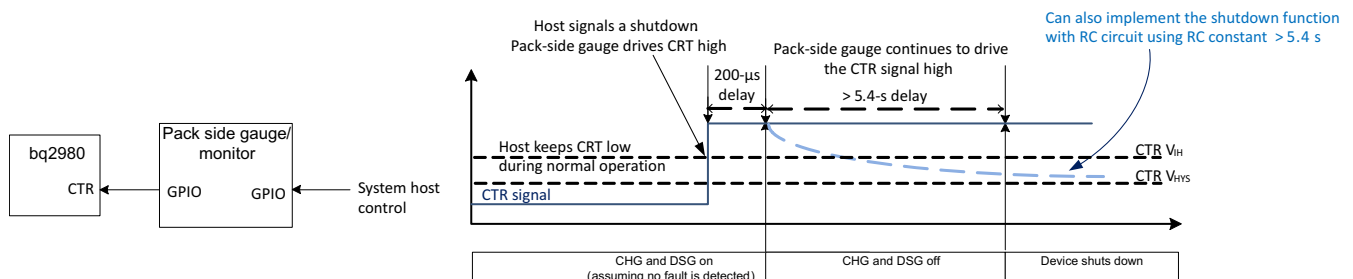
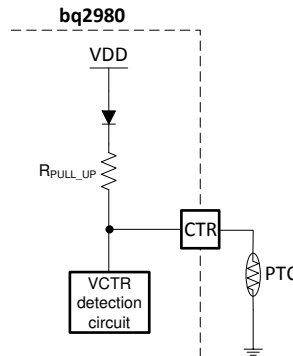

Copyright © 2017, Texas Instruments Incorporated

Figure 7-4. Connecting PTC to CTR Pin for Overtemperature Protection

When any of the CTR internal pull-up resistors are selected (factory configured), an active-high signal ($V_{CTR} > CTR V_{IH}$) on CTR turns off both CHG and DSG outputs, but it does not shut down the device.

As temperature goes up, the PTC resistance increases and when the voltage divided by the internal R_{PULL_UP} and the R_{PTC} is $> CTR V_{IH}$, the CHG and DSG outputs are turned off. As temperature falls and the PTC resistance decreases, the CHG and DSG outputs turn back on when ($V_{CTR} < CTR V_{IL}$).

7.3.9 ZVCHG (0-V Charging)

ZVCHG (0-V charging) is a special function that allows charging a severely depleted battery that is below the FET driver charge pump shutdown voltage (V_{DRIVER_SHUT}). The BQ2980 has ZVCHG enabled, while the BQ2982 device has it disabled.

In BQ2980, if $V_{BAT} > V_{OINH}$ and $VDD < V_{DRIVER_SHUT} - V_{DRIVER_SHUT_HYS}$ and the charger voltage at PACK+ is $> V_{0CHGR}$, then the CHG output will be driven to the voltage of the PACK pin, allowing charging. ZVCHG mode in the BQ2980 is exited when $V_{BAT} > V_{DRIVER_SHUT}$, at which point the charge pump is enabled, and CHG transitions to being driven by the charge pump. In the BQ2982, ZVCHG is entirely disabled, so charging is disabled whenever $VDD < V_{DRIVER_SHUT} - V_{DRIVER_SHUT_HYS}$.

For BQ2980 and BQ2982, when the voltage on VDD is below V_{OINH} , the CHG output becomes high impedance, and any leakage current flowing through the CHG FET may cause this voltage to rise and reenabling charging. If this is undesired, a high impedance resistor can be included between the CHG FET gate and source to overcome any leakage and ensure the FET remains disabled in this case. This resistance should be as high as possible while still ensuring the FET is disabled, since it will increase the device operating current when the CHG driver is enabled. Because gate leakage is typically extremely low, a gate-source resistance of 50 MΩ to 100 MΩ may be sufficient to overcome the leakage.

7.4 Device Functional Modes

7.4.1 Power Modes

7.4.1.1 Power-On-Reset (POR)

The device powers up in SHUTDOWN mode, assuming a UV fault. To enter NORMAL mode, both V_{BAT} and V_{PACK} must meet the UV recovery requirement. In summary, if UV_SHUT is enabled, ($V_{BAT} > V_{UVF}$) and V_{PACK} detecting a charger connection are required to enter NORMAL mode. If UV_SHUT is disabled, ($V_{BAT} > V_{UVF}$) and ($V_{PACK} > \text{the minimum value of VDD}$) are required to enter NORMAL mode. See [Section 7.4.1.4](#) for more details.

During the ZVCHG operation mode (only available in BQ2980), the CHG pin is internally connected to PACK when the device is in SHUTDOWN mode. If both V_{BAT} and V_{PACK} meet the ZVCHG condition (see [セクション 7.3.9](#) for details), CHG is on, even if UV recovery conditions are not met.

7.4.1.2 NORMAL Mode

In NORMAL mode, all configured protections are active. No fault is detected, and both CHG and DSG drivers are enabled. For the BQ298x device, if none of the internal CTR pull-up resistor options is selected, V_{CTR} must be $< CTR V_{IL}$ for CHG and DSG to be on.

7.4.1.3 FAULT Mode

If a protection fault is detected, the device enters FAULT mode. In this mode, the CHG or DSG driver is pulled to V_{FETOFF} to turn off the CHG or DSG FETs.

7.4.1.4 SHUTDOWN Mode

This mode is the lowest power-consumption state of the device, with both CHG and DSG turned off.

The two conditions to enter SHUTDOWN mode are as follows:

- Undervoltage (UV): If the device is configured with UV_SHUT enabled, when UV protection is triggered, the device enters SHUTDOWN mode. See [セクション 7.3.2](#) for details.
- CTR control: When CTR is HIGH for > 5.4 s, the device enters SHUTDOWN mode. See [セクション 7.3.7](#) for details.

注

If the internal CTR pull-up is enabled, a HIGH at CTR does not activate the shutdown process. This is because when the internal pull-up is enabled, the CTR pin is configured for use with an external PTC for overtemperature protection, and the CTR functionality is disabled.

8 Application and Implementation

Application Information Disclaimer

注

Information in the following applications sections is not part of the TI component specification, and TI does not warrant its accuracy or completeness. TI's customers are responsible for determining suitability of components for their purposes, as well as validating and testing their design implementation to confirm system functionality.

8.1 Application Information

8.1.1 Test Circuits for Device Evaluation

1. Test Power Consumption (Test Circuit 1)

This setup is suitable to test for device power consumption at different power modes. VS1 is a voltage source that simulates a battery cell. VS2 is used to simulate a charger and load under different power mode conditions.

I1 is a current meter that monitors the device power consumption at different modes. I2 is a current meter that monitors the PACK pin current. The I_{PACK} current is insignificant in most operation modes. If a charger is connected (VS2 has a positive voltage), but the device is still in SHUTDOWN mode, I2 reflects the I_{PACK} current drawing from the charger due to the internal $R_{PACK-VSS}$ resistor.

2. Test CHG and DSG Voltage and Status (Test Circuit 2)

This setup is suitable to test V_{CHG} and V_{DSG} levels or monitor the CHG and DSG status at different operation modes. It is not suitable to measure power consumption of the device, because the meters (or scope

probes) connected to CHG and/or DSG increase the charge pump loading beyond the normal application condition. Therefore, the current consumption of the device under this setup is greatly increased.

3. *Test for Fault Protection (Test Circuit 3)*

This setup is suitable to test OV, UV, OCD, OCD, and SCD protections.

Voltage protection:

Adjust VS1 to simulation OV and UV. TI recommends having 0 V on VS3 during the voltage test to avoid generating multiple faults. Adjust VS2 to simulate the charger/load connection or disconnection. Combine with test circuit 1 to monitor power consumption, or combine with test circuit 2 to monitor CHG and DSG status.

Test example for OV fault and OV recovery by charger removal:

- Adjust both VS1 and VS2 > OVP threshold.
- As the device triggers for OVP and CHG is open, VS2 can be set to a maximum expected charger voltage as if in an actual application when CHG is open, and charger voltage may regulate to the maximum setting.
- To test for OV recovery, adjust VS1 below $(V_{OVP} - V_{OVP_Hys})$. Reduce the VS2 voltage so that $(VS2 - VS1) < 100\text{ mV}$ (to emulate removal of a charger).

Current protection:

Similar to the voltage protection test, adjust VS3 to simulate OCC, OCD, and SCD thresholds. Use VS2 to simulate a charger/load status. TI recommends setting VS1 to the normal level to avoid triggering multiple faults.

注

It is normal to observe CHG or DSG flipping on and off if VS2 is not set up properly to simulate a charger or load connection/disconnection, especially when the voltage source is used to simulate fault conditions. It is because an improper VS2 setting may mislead the device to sense a recovery condition immediately after a fault protection is triggered.

4. *Test for CTR Control (Test Circuit 4)*

This setup is suitable to test for CTR control. Adjust VS4 above or below the CTR V_{IH} or V_{IL} level. Combine with test circuit 1 to observe the power consumption, or combine with test circuit 2 to observe the CHG and DSG status.

8.1.2 Test Circuit Diagrams



図 8-1. Test Circuit 1



図 8-2. Test Circuit 2

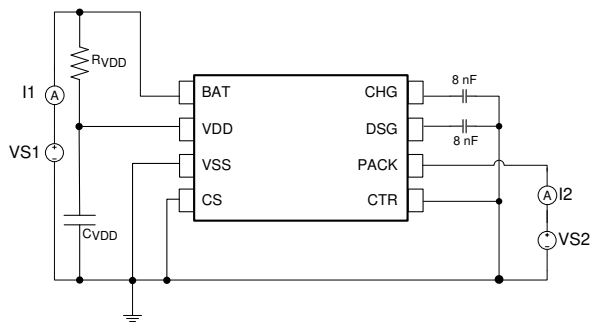

Copyright © 2017, Texas Instruments Incorporated

8-3. Test Circuit 3

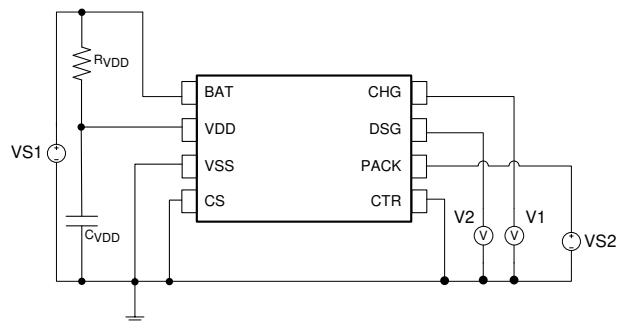
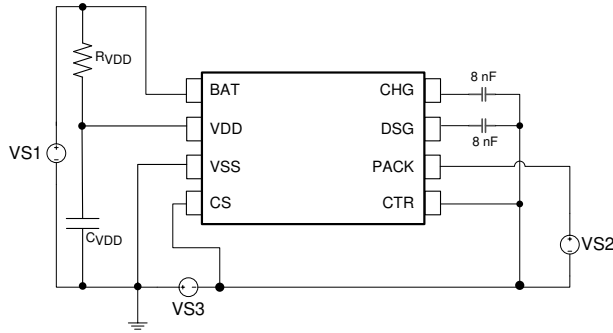
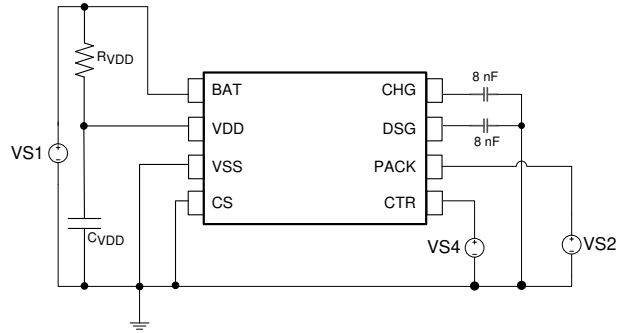

Copyright © 2017, Texas Instruments Incorporated

8-4. Test Circuit 4

8.1.3 Using CTR as FET Driver On/Off Control

Normally, CTR is not designed as a purely on/off control of the FET drivers, because there is a timing constriction on the pin. The following is a list of workarounds to implement the CTR as an on/off switch to the FET drivers.

1. *Switching CTR from high to low with less than 3.6 s:*

If the application only requires turning off the FET drivers in < 3.6 s, then the CTR pin can simply be viewed as an on/off switch of the FET drivers. That means, after the CTR pin is pulled high, the application will pull the CTR pin back low in < 3.6 s.

2. *Applying a voltage on PACK to prevent the device from entering SHUTDOWN mode:*

When the CTR pin is pulled high for > 3.6 s, there is a chance the device may go into SHUTDOWN mode. If the CTR pin is high for > 5.4 s, the device will be in SHUTDOWN mode. For applications that may use the CTR to keep the FET drivers off for > 3.6 s, the workaround is to keep V_{PACK} within the VDD recommended operating range while the CTR is pulled high to prevent the device from entering SHUTDOWN mode. The device is forced to stay in NORMAL mode with this method.

Because the PACK pin is also connected to the PACK terminal, the system designer should have a blocking diode to protect the GPIO (that controls the CTR pin) from high voltage.

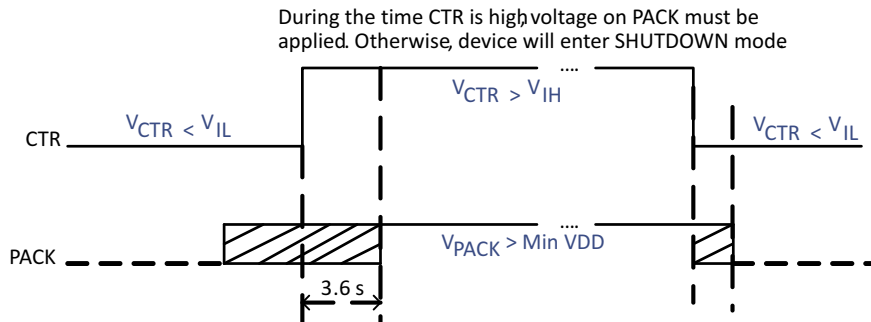

When CTR is pulled high (FETs off), the system ensures:

1. Voltage on PACK is applied before pulling CTR high or
2. Voltage on PACK is applied within 3.6 s after CTR is pulled high.

When CTR is pulled low (FET on), the system ensures:

1. Voltage on PACK is still applied before pulling CTR low.

Copyright © 2017, Texas Instruments Incorporated

8-5. PACK Voltage Timing with Switching CTR as On/Off Control of FET Drivers

8.2 Typical Applications

8.2.1 BQ298x Configuration 1: System-Controlled Reset/Shutdown Function

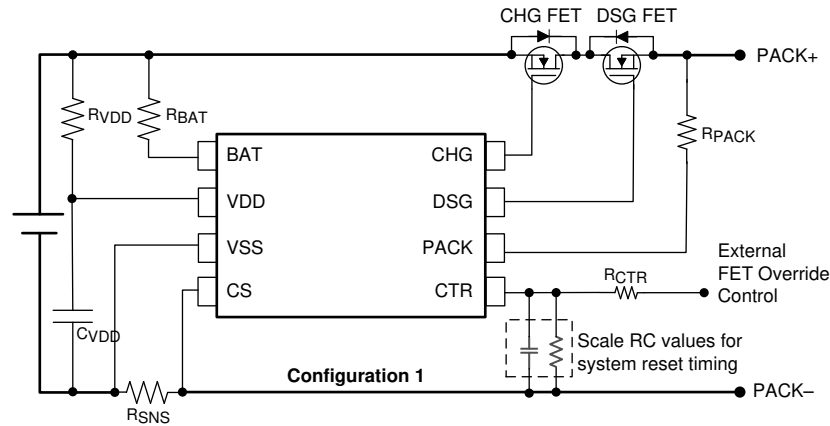

8-6. BQ298x Reference Schematic Configuration 1

8.2.1.1 Design Requirements

For this design example, use the parameters listed in [Table 8-1](#).

Table 8-1. Recommended Component Selection

PARAMETER	TYP	MAX	UNIT	COMMENT
R _{PACK} PACK resistor	—	2	kΩ	This resistor is used to protect the PACK pin from a reserve charging current condition.
R _{VDD} VDD filter resistor	—	300	Ω	
C _{VDD} VDD filter capacitor	0.1	1	μF	
R _{BAT} BAT resistor (for safety. To limit current if BAT pin is shorted internally)	20	—	Ω	This resistor limits current if the BAT pin is shorted to ground internally. BAT is used for voltage measurement for OV and UV. A larger resistor value can impact the voltage measurement accuracy.
R _{CTR} CTR resistor (optional for ESD)	100	—	Ω	This is optional for ESD protection and is highly dependent on the PCB layout.

8.2.1.2 Detailed Design Procedure

- Determine if a CTR for FET override or an improved voltage measurement function is required in the battery pack design.
- See [Figure 8-6](#) for the schematic design.
- Check the cell specification and system requirement to determine OV and UV levels.
- Define the sense resistor value and system requirement to determine OCC, OCD, and SCD levels. For example, with a 1-mΩ sense resistor and OCC, OCD, and SCD, the requirement is 6 A, 8 A, and 20 A, respectively. The OCC threshold should be set to 6 mV, the OCD threshold should be at 8 mV, and the SCD threshold should be at 20 mV.
- Determine the required OT protection threshold. The OT fault turns off the CHG and the DSG, so the threshold must account for the highest allowable charge and discharge temperature range.
- When a decision is made on the various thresholds, search for whether a device configuration is available or contact the local sales office for more information.

8.2.1.3 Selection of Power FET

The high-side driver of the BQ298x device limits the V_{gs} below 8 V with a 4.4-V battery cell. This means the device can work with a power FET with an absolute maximum rating as low as ±8 V V_{gs}, which is common in smartphone applications.

Additionally, TI highly recommends using a low gate leakage FET around 6-V to 7-V V_{gs} range. The power FET on the BQ298x evaluation module has the following typical gate leakage. TI recommends selecting a similar gate leakage FET for the design.

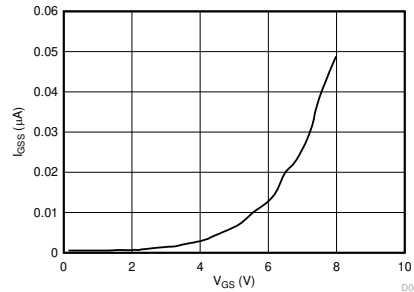

8-7. Power FET (on BQ2980 EVM) Gate Leakage Versus V_{gs}

8.2.1.4 Application Curves

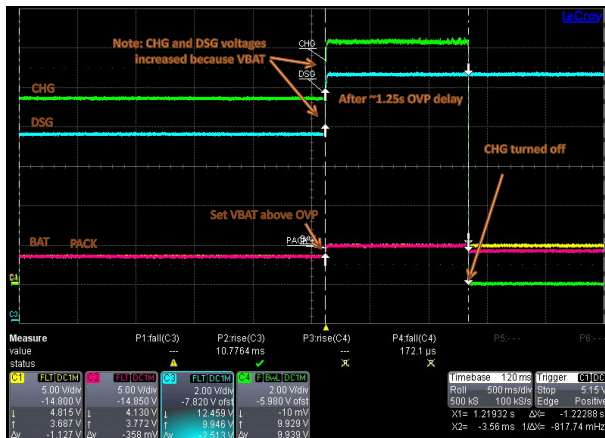

8-8. Overvoltage (OV) Protection

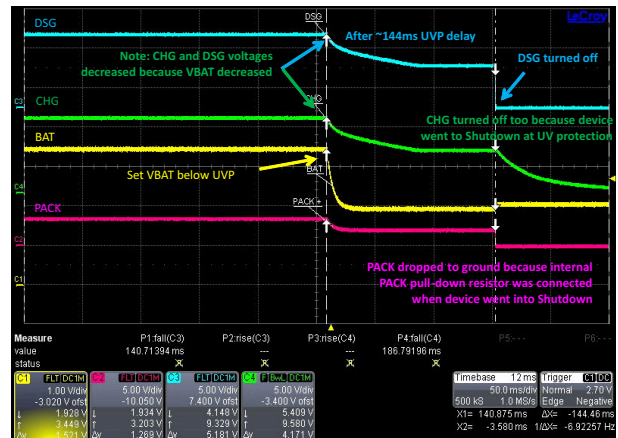

8-9. Undervoltage (UV) Protection

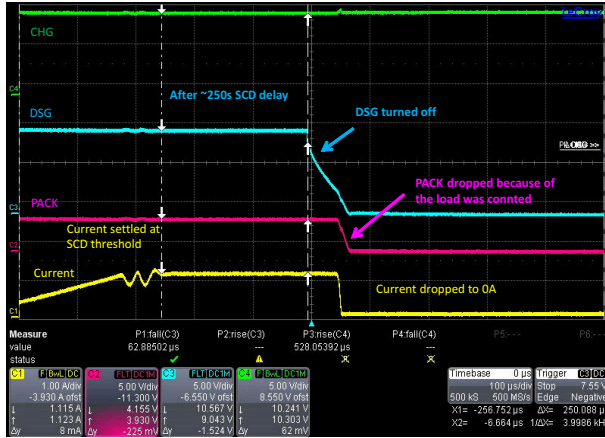

8-10. Short Circuit (SCD) Protection

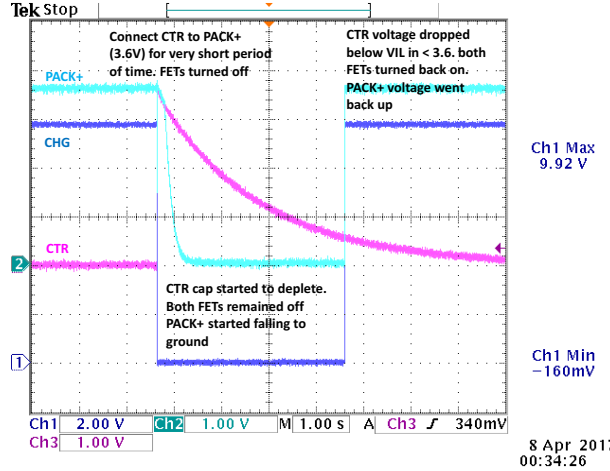

The RC values used in this example are for reference only. System designers should depend on their pull-up voltage and RC tolerance to add any additional margin. TI also recommends users keep the delay time below 3.6 s, if possible, for the reset function.

8-11. Setup CTR for System Reset (Using 5 MΩ and 1 μF RC)

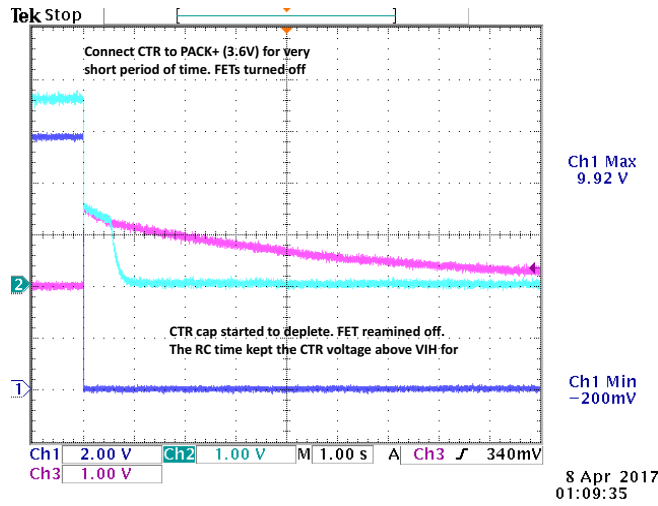

The RC values used in this example are for reference only. System designers should depend on their pull-up voltage and RC tolerance to add any additional margin. TI also recommends users keep the delay time below 5.4 s, if possible, for the shutdown function.

8-12. Setup CTR for System Shutdown (Using 5 MΩ and 1 μF RC)

8.2.2 BQ298x Configuration 2: CTR Function Disabled



图 8-13. BQ298x Reference Schematic Configuration 2

8.2.3 BQ298x Configuration 3: PTC Thermistor Protection

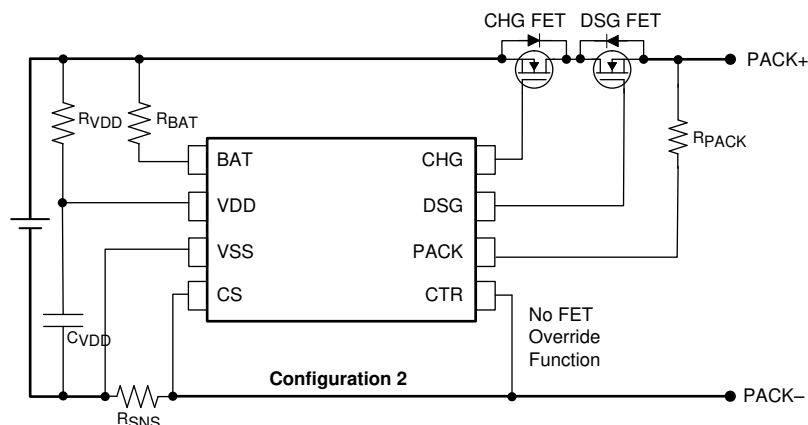

图 8-14. BQ298x Reference Schematic Configuration 3

9 Power Supply Recommendations

The device supports single-cell li-ion and li-polymer batteries of various chemistries with a maximum VDD below 5.5 V.

10 Layout

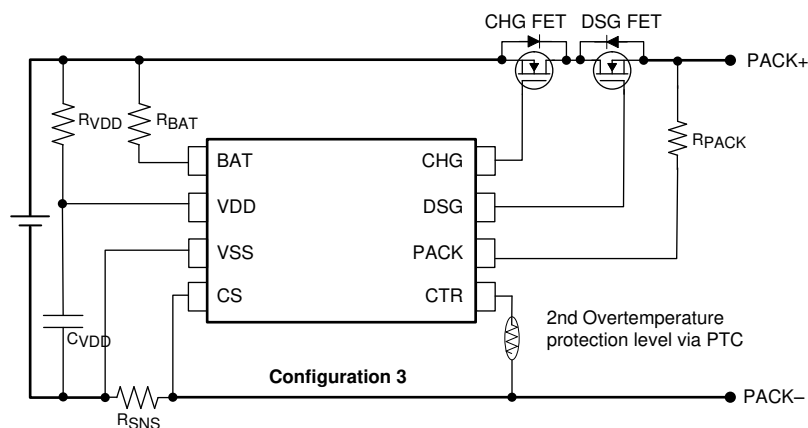
10.1 Layout Guidelines

1. Place the components to optimize the layout. For example, group the high-power components like cell pads, PACK+ and PACK- pads, power FETs, and R_{SNS} together, allowing the layout to optimize the power traces for the best thermal heat spreading.
2. Separate the device's VSS and low-power components to a low-current ground plane. Both grounds can meet at R_{SNS} .
3. Place the VDD RC filter close to the device's VDD pin.

10.2 Layout Example

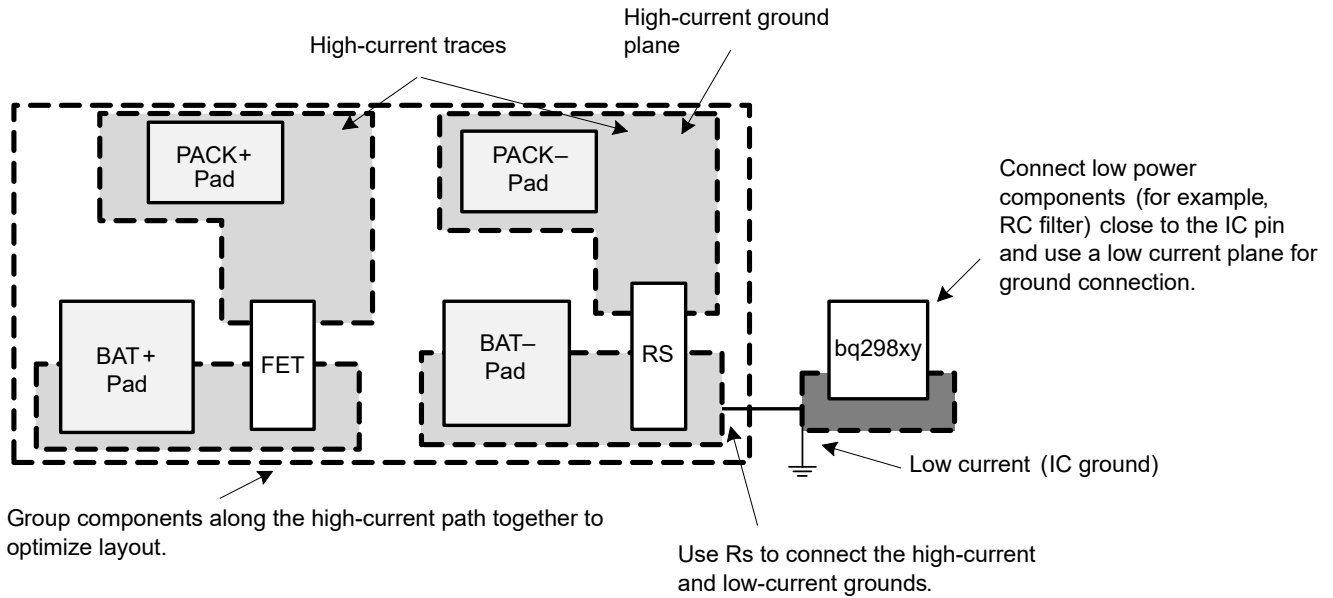

10-1. Component Placement and Grounding Pattern Example

11 Device and Documentation Support

11.1 サード・パーティ製品に関する免責事項

サード・パーティ製品またはサービスに関するテキサス・インスツルメンツの出版物は、単独またはテキサス・インスツルメンツの製品、サービスと一緒に提供される場合に関係なく、サード・パーティ製品またはサービスの適合性に関する是認、サード・パーティ製品またはサービスの是認の表明を意味するものではありません。

11.2 ドキュメントの更新通知を受け取る方法

ドキュメントの更新についての通知を受け取るには、www.tij.co.jp のデバイス製品フォルダを開いてください。[通知] をクリックして登録すると、変更されたすべての製品情報に関するダイジェストを毎週受け取ることができます。変更の詳細については、改訂されたドキュメントに含まれている改訂履歴をご覧ください。

11.3 サポート・リソース

テキサス・インスツルメンツ E2E™ サポート・フォーラムは、エンジニアが検証済みの回答と設計に関するヒントをエキスパートから迅速かつ直接得ることができる場所です。既存の回答を検索したり、独自の質問をしたりすることで、設計に必要な支援を迅速に得ることができます。

リンクされているコンテンツは、各寄稿者により「現状のまま」提供されるものです。これらはテキサス・インスツルメンツの仕様を構成するものではなく、必ずしもテキサス・インスツルメンツの見解を反映したものではありません。テキサス・インスツルメンツの[使用条件](#)を参照してください。

11.4 Trademarks

テキサス・インスツルメンツ E2E™ is a trademark of Texas Instruments.

すべての商標は、それぞれの所有者に帰属します。

11.5 静電気放電に関する注意事項



この IC は、ESD によって破損する可能性があります。テキサス・インスツルメンツは、IC を取り扱う際には常に適切な注意を払うことを推奨します。正しい取り扱いおよび設置手順に従わない場合、デバイスを破損するおそれがあります。

ESD による破損は、わずかな性能低下からデバイスの完全な故障まで多岐にわたります。精密な IC の場合、パラメータがわずかに変化するだけで公表されている仕様から外れる可能性があるため、破損が発生しやすくなっています。

11.6 用語集

テキサス・インスツルメンツ用語集

この用語集には、用語や略語の一覧および定義が記載されています。

12 Revision History

資料番号末尾の英字は改訂を表しています。その改訂履歴は英語版に準じています。

Changes from Revision J (December 2022) to Revision K (July 2024) Page

- Added the BQ298218 device to the [Device Comparison Table](#) 3

Changes from Revision I (November 2021) to Revision J (December 2022) Page

- Added the BQ298217 device to the [Device Comparison Table](#) 3

Changes from Revision H (July 2021) to Revision I (November 2021) Page

- Changed the [Device Comparison Table](#) 3

Changes from Revision G (May 2021) to Revision H (July 2021) Page

- Changed the BQ298019 device from PRODUCT PREVIEW to Production Data in the [Device Comparison Table](#) 3

Changes from Revision F (December 2020) to Revision G (May 2021) Page

- 「概要」の BQ2982 から「製品プレビュー」の脚注を削除 1
- Changed the [Device Comparison Table](#) 3
- Removed PRODUCT PREVIEW footnote from BQ2982xy in [Thermal Information](#) 4
- Clarified CHG driver at low VDD in [Electrical Characteristics](#) 5
- Clarified VDD condition in [Charge and Discharge Driver](#) 11
- Clarified ZVCHG in [ZVCHG \(0-V Charging\)](#) 13

Changes from Revision E (January 2020) to Revision F (December 2020) Page

- タイトルと文書のテキスト全体を通して BQ2982xy を追加 1
- BQ2980 のみが 0V 充電をサポートするという注を「特長」に追加 1
- 「概要」に BQ2980 と BQ2982 の違いについての説明を追加 1
- 「製品情報」の表に BQ2982 デバイス ファミリーを追加 1
- Added the BQ298018 and BQ298215 devices to the [Device Comparison Table](#) ; changed BQ298006, BQ298009, and BQ298015 devices from custom to catalog devices; added a table footnote for clarity regarding the CTR R_{PULL_UP} 3
- Included BQ2982xy in [Thermal Information](#) 4
- Added clarification that ZVCHG and associated specifications only apply to BQ2980xy, not to BQ2982xy in [Electrical Characteristics](#) 5
- Changed specification for V_{UVP_ACC} in [Electrical Characteristics](#) 5
- Corrected units for V_{UVP_HYS} specification in [Electrical Characteristics](#) 5
- Clarified description of V_{DRIVER_SHUT_HYS} and added V_{DRIVER_SHUT_HYS} specification in [Electrical Characteristics](#) 5
- Corrected error in [Device Configuration Range](#) table 9
- Added clarification on UV_SHUT and ZVCHG options in [Undervoltage \(UV\) Status](#) 10

• Added clarification regarding ZVCHG in Charge and Discharge Driver	11
• Clarified ZVCHG in ZVCHG (0-V Charging)	13
• Added clarification regarding ZVCHG in the BQ2980 device in Power-On-Reset (POR)	13

Changes from Revision D (August 2019) to Revision E (January 2020)	Page
• 低温 (UT) を削除	1
• Changed the Device Comparison Table	3
• Changed BQ298010 and BQ298012 devices from custom to catalog devices	3

Changes from Revision C (May 2018) to Revision D (August 2019)	Page
• 「 概略回路図 」のバッテリー アイコンをバッテリー回路図記号に置き換え	1
• Added the battery schematic symbol in BQ298x Reference Schematic Configuration 1	17
• Added the battery schematic symbol in BQ298x Reference Schematic Configuration 2	20
• Added the battery schematic symbol in BQ298x Reference Schematic Configuration 3	20

Changes from Revision B (February 2018) to Revision C (May 2018)	Page
• 「 特長 」に 0V 充電を追加	1
• Changed the Device Comparison Table	3
• Changed Undervoltage (UV) Status	10

Changes from Revision A (January 2018) to Revision B (February 2018)	Page
• Changed the Device Comparison Table	3

Changes from Revision * (October 2017) to Revision A (January 2018)	Page
• Changed the Device Comparison Table	3
• Changed I _{NORMAL} test conditions in Electrical Characteristics	5
• Changed V _{OC} test conditions in Electrical Characteristics	5
• Changed I _{OC} _REC in Electrical Characteristics	5

13 Mechanical, Packaging, and Orderable Information

The following pages include mechanical, packaging, and orderable information. This information is the most current data available for the designated devices. This data is subject to change without notice and revision of this document. For browser-based versions of this data sheet, refer to the left-hand navigation.

重要なお知らせと免責事項

テキサス・インスツルメンツは、技術データと信頼性データ (データシートを含みます)、設計リソース (リファレンス デザインを含みます)、アプリケーションや設計に関する各種アドバイス、Web ツール、安全性情報、その他のリソースを、欠陥が存在する可能性のある「現状のまま」提供しており、商品性および特定目的に対する適合性の黙示保証、第三者の知的財産権の非侵害保証を含むいかなる保証も、明示的または黙示的にかかわらず拒否します。

これらのリソースは、テキサス・インスツルメンツ製品を使用する設計の経験を積んだ開発者への提供を意図したものです。(1) お客様のアプリケーションに適した テキサス・インスツルメンツ製品の選定、(2) お客様のアプリケーションの設計、検証、試験、(3) お客様のアプリケーションに該当する各種規格や、その他のあらゆる安全性、セキュリティ、規制、または他の要件への確実な適合に関する責任を、お客様のみが単独で負うものとします。

上記の各種リソースは、予告なく変更される可能性があります。これらのリソースは、リソースで説明されている テキサス・インスツルメンツ製品を使用するアプリケーションの開発の目的でのみ、テキサス・インスツルメンツはその使用をお客様に許諾します。これらのリソースに関して、他の目的で複製することや掲載することは禁止されています。テキサス・インスツルメンツや第三者の知的財産権のライセンスが付与されている訳ではありません。お客様は、これらのリソースを自身で使用した結果発生するあらゆる申し立て、損害、費用、損失、責任について、テキサス・インスツルメンツおよびその代理人を完全に補償するものとし、テキサス・インスツルメンツは一切の責任を拒否します。

テキサス・インスツルメンツの製品は、[テキサス・インスツルメンツの販売条件](#)、または [ti.com](https://www.ti.com) やかかる テキサス・インスツルメンツ製品の関連資料などのいずれかを通じて提供する適用可能な条項の下で提供されています。テキサス・インスツルメンツがこれらのリソースを提供することは、適用されるテキサス・インスツルメンツの保証または他の保証の放棄の拡大や変更を意味するものではありません。

お客様がいかなる追加条項または代替条項を提案した場合でも、テキサス・インスツルメンツはそれらに異議を唱え、拒否します。

郵送先住所: Texas Instruments, Post Office Box 655303, Dallas, Texas 75265

Copyright © 2024, Texas Instruments Incorporated

PACKAGING INFORMATION

Orderable Device	Status (1)	Package Type	Package Drawing	Pins	Package Qty	Eco Plan (2)	Lead finish/ Ball material (6)	MSL Peak Temp (3)	Op Temp (°C)	Device Marking (4/5)	Samples
BQ298000RUGR	ACTIVE	X2QFN	RUG	8	3000	RoHS & Green	NIPDAU	Level-1-260C-UNLIM	-40 to 85	51	Samples
BQ298000RUGT	ACTIVE	X2QFN	RUG	8	250	RoHS & Green	NIPDAU	Level-1-260C-UNLIM	-40 to 85	51	Samples
BQ298006RUGR	ACTIVE	X2QFN	RUG	8	3000	RoHS & Green	NIPDAU	Level-1-260C-UNLIM	-40 to 85	51 06	Samples
BQ298006RUGT	ACTIVE	X2QFN	RUG	8	250	RoHS & Green	NIPDAU	Level-1-260C-UNLIM	-40 to 85	51 06	Samples
BQ298009RUGR	ACTIVE	X2QFN	RUG	8	3000	RoHS & Green	NIPDAU	Level-1-260C-UNLIM	-40 to 85	51 09	Samples
BQ298009RUGT	ACTIVE	X2QFN	RUG	8	250	RoHS & Green	NIPDAU	Level-1-260C-UNLIM	-40 to 85	51 09	Samples
BQ298010RUGR	ACTIVE	X2QFN	RUG	8	3000	RoHS & Green	NIPDAU	Level-1-260C-UNLIM	-40 to 85	51 10	Samples
BQ298010RUGT	ACTIVE	X2QFN	RUG	8	250	RoHS & Green	NIPDAU	Level-1-260C-UNLIM	-40 to 85	51 10	Samples
BQ298012RUGR	ACTIVE	X2QFN	RUG	8	3000	RoHS & Green	NIPDAU	Level-1-260C-UNLIM	-40 to 85	51 12	Samples
BQ298012RUGT	ACTIVE	X2QFN	RUG	8	250	RoHS & Green	NIPDAU	Level-1-260C-UNLIM	-40 to 85	51 12	Samples
BQ298015RUGR	ACTIVE	X2QFN	RUG	8	3000	RoHS & Green	NIPDAU	Level-1-260C-UNLIM	-40 to 85	51 15	Samples
BQ298015RUGT	ACTIVE	X2QFN	RUG	8	250	RoHS & Green	NIPDAU	Level-1-260C-UNLIM	-40 to 85	51 15	Samples
BQ298018RUGR	ACTIVE	X2QFN	RUG	8	3000	RoHS & Green	NIPDAU	Level-1-260C-UNLIM	-40 to 85	51 18	Samples
BQ298019RUGR	ACTIVE	X2QFN	RUG	8	3000	RoHS & Green	NIPDAU	Level-1-260C-UNLIM	-40 to 85	51 19	Samples
BQ298215RUGR	ACTIVE	X2QFN	RUG	8	3000	RoHS & Green	NIPDAU	Level-1-260C-UNLIM	-40 to 85	82 15	Samples
BQ298216RUGR	ACTIVE	X2QFN	RUG	8	3000	RoHS & Green	NIPDAU	Level-1-260C-UNLIM	-40 to 85	82 16	Samples
BQ298217RUGR	ACTIVE	X2QFN	RUG	8	3000	RoHS & Green	NIPDAU	Level-1-260C-UNLIM	-40 to 85	82 17	Samples

Orderable Device	Status (1)	Package Type	Package Drawing	Pins	Package Qty	Eco Plan (2)	Lead finish/ Ball material (6)	MSL Peak Temp (3)	Op Temp (°C)	Device Marking (4/5)	Samples
BQ298218RUGR	ACTIVE	X2QFN	RUG	8	3000	RoHS & Green	NIPDAU	Level-1-260C-UNLIM	-40 to 85	82 18	Samples

(1) The marketing status values are defined as follows:

ACTIVE: Product device recommended for new designs.

LIFEBUY: TI has announced that the device will be discontinued, and a lifetime-buy period is in effect.

NRND: Not recommended for new designs. Device is in production to support existing customers, but TI does not recommend using this part in a new design.

PREVIEW: Device has been announced but is not in production. Samples may or may not be available.

OBSOLETE: TI has discontinued the production of the device.

(2) **RoHS:** TI defines "RoHS" to mean semiconductor products that are compliant with the current EU RoHS requirements for all 10 RoHS substances, including the requirement that RoHS substance do not exceed 0.1% by weight in homogeneous materials. Where designed to be soldered at high temperatures, "RoHS" products are suitable for use in specified lead-free processes. TI may reference these types of products as "Pb-Free".

RoHS Exempt: TI defines "RoHS Exempt" to mean products that contain lead but are compliant with EU RoHS pursuant to a specific EU RoHS exemption.

Green: TI defines "Green" to mean the content of Chlorine (Cl) and Bromine (Br) based flame retardants meet JS709B low halogen requirements of <=1000ppm threshold. Antimony trioxide based flame retardants must also meet the <=1000ppm threshold requirement.

(3) MSL, Peak Temp. - The Moisture Sensitivity Level rating according to the JEDEC industry standard classifications, and peak solder temperature.

(4) There may be additional marking, which relates to the logo, the lot trace code information, or the environmental category on the device.

(5) Multiple Device Markings will be inside parentheses. Only one Device Marking contained in parentheses and separated by a "~" will appear on a device. If a line is indented then it is a continuation of the previous line and the two combined represent the entire Device Marking for that device.

(6) Lead finish/Ball material - Orderable Devices may have multiple material finish options. Finish options are separated by a vertical ruled line. Lead finish/Ball material values may wrap to two lines if the finish value exceeds the maximum column width.

Important Information and Disclaimer:The information provided on this page represents TI's knowledge and belief as of the date that it is provided. TI bases its knowledge and belief on information provided by third parties, and makes no representation or warranty as to the accuracy of such information. Efforts are underway to better integrate information from third parties. TI has taken and continues to take reasonable steps to provide representative and accurate information but may not have conducted destructive testing or chemical analysis on incoming materials and chemicals. TI and TI suppliers consider certain information to be proprietary, and thus CAS numbers and other limited information may not be available for release.

In no event shall TI's liability arising out of such information exceed the total purchase price of the TI part(s) at issue in this document sold by TI to Customer on an annual basis.

TAPE AND REEL INFORMATION



QUADRANT ASSIGNMENTS FOR PIN 1 ORIENTATION IN TAPE

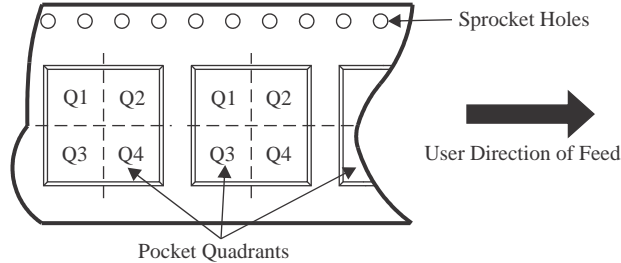

*All dimensions are nominal

Device	Package Type	Package Drawing	Pins	SPQ	Reel Diameter (mm)	Reel Width W1 (mm)	A0 (mm)	B0 (mm)	K0 (mm)	P1 (mm)	W (mm)	Pin1 Quadrant
BQ298000RUGR	X2QFN	RUG	8	3000	180.0	9.5	1.69	1.69	0.63	4.0	8.0	Q2
BQ298000RUGT	X2QFN	RUG	8	250	180.0	9.5	1.69	1.69	0.63	4.0	8.0	Q2
BQ298006RUGR	X2QFN	RUG	8	3000	180.0	9.5	1.69	1.69	0.63	4.0	8.0	Q2
BQ298006RUGT	X2QFN	RUG	8	250	180.0	9.5	1.69	1.69	0.63	4.0	8.0	Q2
BQ298009RUGR	X2QFN	RUG	8	3000	180.0	9.5	1.69	1.69	0.63	4.0	8.0	Q2
BQ298009RUGT	X2QFN	RUG	8	250	180.0	9.5	1.69	1.69	0.63	4.0	8.0	Q2
BQ298010RUGR	X2QFN	RUG	8	3000	180.0	9.5	1.69	1.69	0.63	4.0	8.0	Q2
BQ298010RUGT	X2QFN	RUG	8	250	180.0	9.5	1.69	1.69	0.63	4.0	8.0	Q2
BQ298012RUGR	X2QFN	RUG	8	3000	180.0	9.5	1.69	1.69	0.63	4.0	8.0	Q2
BQ298012RUGT	X2QFN	RUG	8	250	180.0	9.5	1.69	1.69	0.63	4.0	8.0	Q2
BQ298015RUGR	X2QFN	RUG	8	3000	180.0	9.5	1.69	1.69	0.63	4.0	8.0	Q2
BQ298015RUGT	X2QFN	RUG	8	250	180.0	9.5	1.69	1.69	0.63	4.0	8.0	Q2
BQ298018RUGR	X2QFN	RUG	8	3000	180.0	9.5	1.69	1.69	0.63	4.0	8.0	Q2
BQ298019RUGR	X2QFN	RUG	8	3000	180.0	9.5	1.69	1.69	0.63	4.0	8.0	Q2
BQ298215RUGR	X2QFN	RUG	8	3000	180.0	9.5	1.69	1.69	0.63	4.0	8.0	Q2
BQ298216RUGR	X2QFN	RUG	8	3000	180.0	9.5	1.69	1.69	0.63	4.0	8.0	Q2

Device	Package Type	Package Drawing	Pins	SPQ	Reel Diameter (mm)	Reel Width W1 (mm)	A0 (mm)	B0 (mm)	K0 (mm)	P1 (mm)	W (mm)	Pin1 Quadrant
BQ298217RUGR	X2QFN	RUG	8	3000	180.0	9.5	1.69	1.69	0.63	4.0	8.0	Q2
BQ298218RUGR	X2QFN	RUG	8	3000	180.0	9.5	1.69	1.69	0.63	4.0	8.0	Q2

TAPE AND REEL BOX DIMENSIONS



*All dimensions are nominal

Device	Package Type	Package Drawing	Pins	SPQ	Length (mm)	Width (mm)	Height (mm)
BQ298000RUGR	X2QFN	RUG	8	3000	189.0	185.0	36.0
BQ298000RUGT	X2QFN	RUG	8	250	189.0	185.0	36.0
BQ298006RUGR	X2QFN	RUG	8	3000	189.0	185.0	36.0
BQ298006RUGT	X2QFN	RUG	8	250	189.0	185.0	36.0
BQ298009RUGR	X2QFN	RUG	8	3000	189.0	185.0	36.0
BQ298009RUGT	X2QFN	RUG	8	250	189.0	185.0	36.0
BQ298010RUGR	X2QFN	RUG	8	3000	189.0	185.0	36.0
BQ298010RUGT	X2QFN	RUG	8	250	189.0	185.0	36.0
BQ298012RUGR	X2QFN	RUG	8	3000	189.0	185.0	36.0
BQ298012RUGT	X2QFN	RUG	8	250	189.0	185.0	36.0
BQ298015RUGR	X2QFN	RUG	8	3000	189.0	185.0	36.0
BQ298015RUGT	X2QFN	RUG	8	250	189.0	185.0	36.0
BQ298018RUGR	X2QFN	RUG	8	3000	189.0	185.0	36.0
BQ298019RUGR	X2QFN	RUG	8	3000	189.0	185.0	36.0
BQ298215RUGR	X2QFN	RUG	8	3000	189.0	185.0	36.0
BQ298216RUGR	X2QFN	RUG	8	3000	189.0	185.0	36.0
BQ298217RUGR	X2QFN	RUG	8	3000	189.0	185.0	36.0
BQ298218RUGR	X2QFN	RUG	8	3000	189.0	185.0	36.0

RUG (R-PQFP-N8)

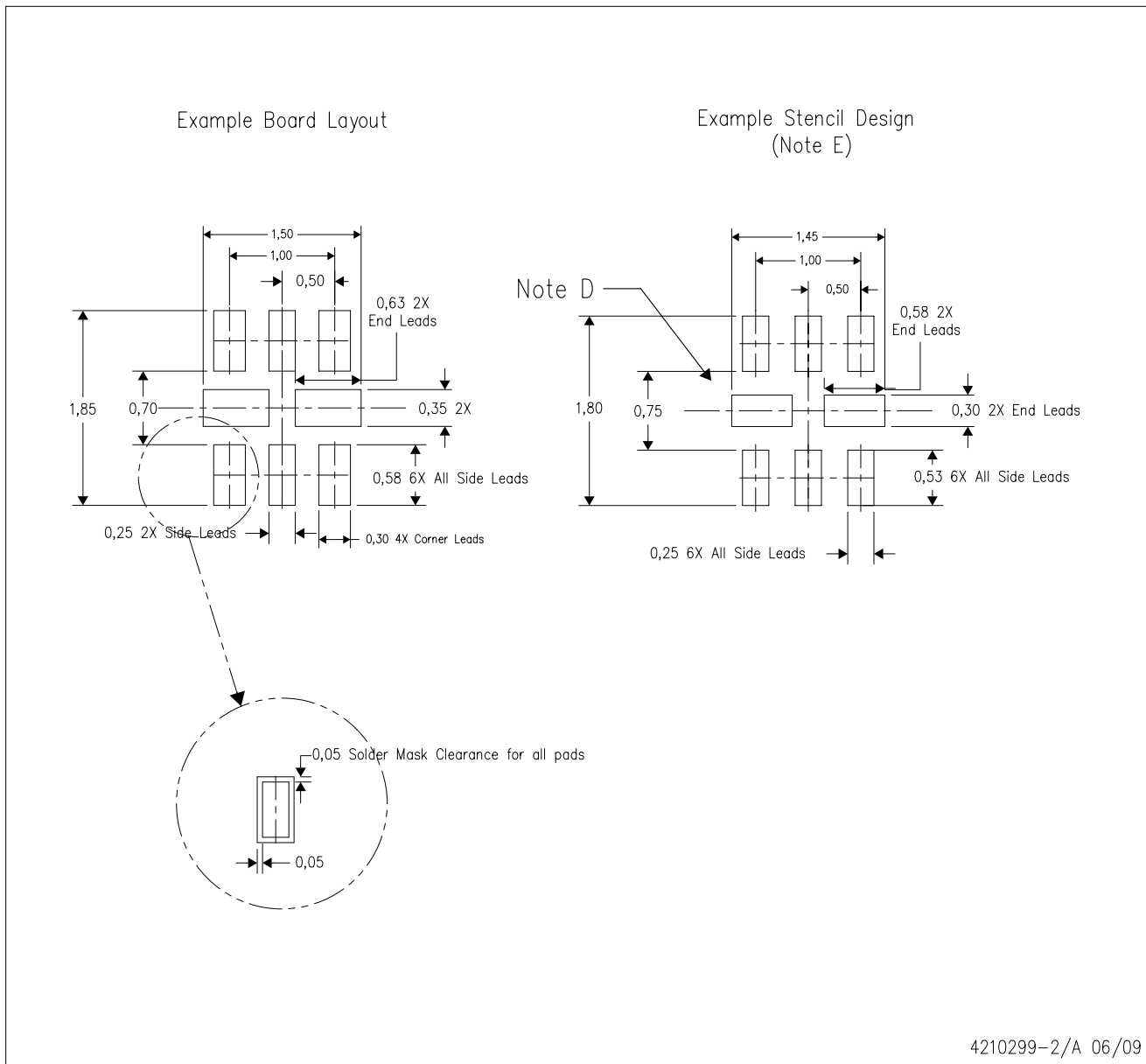

4210299-2/A 06/09

- NOTES:
- A. All linear dimensions are in millimeters.
 - B. This drawing is subject to change without notice.
 - C. Publication IPC-7351 is recommended for alternate designs.
 - D. Customers should contact their board fabrication site for minimum solder mask web tolerances between signal pads.
 - E. Maximum stencil thickness 0,127 mm (5 mils). All linear dimensions are in millimeters.
 - F. Laser cutting apertures with trapezoidal walls and also rounding corners will offer better paste release. Customers should contact their board assembly site for stencil design recommendations. Refer to IPC 7525 for stencil design considerations.
 - G. Side aperture dimensions over-print land for acceptable area ratio > 0.66. Customer may reduce side aperture dimensions if stencil manufacturing process allows for sufficient release at smaller opening.

重要なお知らせと免責事項

TI は、技術データと信頼性データ (データシートを含みます)、設計リソース (リファレンス・デザインを含みます)、アプリケーションや設計に関する各種アドバイス、Web ツール、安全性情報、その他のリソースを、欠陥が存在する可能性のある「現状のまま」提供しており、商品性および特定目的に対する適合性の黙示保証、第三者の知的財産権の非侵害保証を含むいかなる保証も、明示的または黙示的にかかわらず拒否します。

これらのリソースは、TI 製品を使用する設計の経験を積んだ開発者への提供を意図したものです。(1) お客様のアプリケーションに適した TI 製品の選定、(2) お客様のアプリケーションの設計、検証、試験、(3) お客様のアプリケーションに該当する各種規格や、その他のあらゆる安全性、セキュリティ、規制、または他の要件への確実な適合に関する責任を、お客様のみが単独で負うものとし、

上記の各種リソースは、予告なく変更される可能性があります。これらのリソースは、リソースで説明されている TI 製品を使用するアプリケーションの開発の目的でのみ、TI はその使用をお客様に許諾します。これらのリソースに関して、他の目的で複製することや掲載することは禁止されています。TI や第三者の知的財産権のライセンスが付与されている訳ではありません。お客様は、これらのリソースを自身で使用した結果発生するあらゆる申し立て、損害、費用、損失、責任について、TI およびその代理人を完全に補償するものとし、TI は一切の責任を拒否します。

TI の製品は、[TI の販売条件](#)、または [ti.com](#) やかかる TI 製品の関連資料などのいずれかを通じて提供する適用可能な条項の下で提供されています。TI がこれらのリソースを提供することは、適用される TI の保証または他の保証の放棄の拡大や変更を意味するものではありません。

お客様がいかなる追加条項または代替条項を提案した場合でも、TI はそれらに異議を唱え、拒否します。

郵送先住所 : Texas Instruments, Post Office Box 655303, Dallas, Texas 75265
Copyright © 2024, Texas Instruments Incorporated