

BQ7718 2 直列～5 直列セルのリチウムイオン・バッテリー 用過電圧保護、内部遅延タイマ付き

1 特長

- 2、3、4、5 直列セルの過電圧保護
- 内部遅延タイマ
- 固定 OVP スレッシュホールド
- 高精度の過電圧保護： $\pm 10\text{mV}$
- 低消費電力 $I_{CC} \approx 1\mu\text{A}$
($V_{CELL(ALL)} < V_{PROTECT}$)
- セル入力あたりのリーク電流が低い: 100nA 未満
- 機能安全対応
 - 機能安全システムの設計に役立つ資料を利用可能
- パッケージの占有面積オプション:
 - 小型の 8 ピン QFN (3.00mm × 4.00mm)
 - リード付き 8 ピン MSOP (3.00mm × 5.00mm、リードを含む)

2 アプリケーション

- 次のものに使用されるリチウムイオン・バッテリー・パックの保護:
 - ハンドヘルド園芸用器具
 - ハンドヘルド電動工具
 - コードレス真空掃除機
 - UPS バッテリー・バックアップ
 - 軽量電動車両(電動自転車、電動スクーター、ペダル・アシスト自転車)

3 概要

BQ7718xy 製品ファミリーは、リチウムイオン・バッテリー・パック・システム用の過電圧モニタおよびプロテクタを提供します。各セルの過電圧状況を個別に監視できます。生産ライン・テストを迅速に行えるよう、BQ7718xy デバイスは遅延時間を大幅に削減したカスタム・テスト・モード (CTM) を備えています。

BQ7718xy デバイスでは、いずれかのセルで過電圧状態が検出されると、内部遅延タイマが起動します。遅延タイマが満了すると、出力はアクティブ状態へとトリガされます (構成により HIGH または LOW)。

「製品情報」の表

部品番号	パッケージ	本体サイズ (公称)
BQ771800 ⁽¹⁾	DPJ (8)	3.00mm × 4.00mm
BQ771800 ⁽²⁾	DGK (8)	3.00mm × 3.00mm (3.00mm × 5.00mm、リード含む)

- (1) 利用可能なカタログ・パッケージについては、このデータシートの末尾にある注文情報および [セクション 5](#) を参照してください。
- (2) 詳細は TI までお問い合わせください。

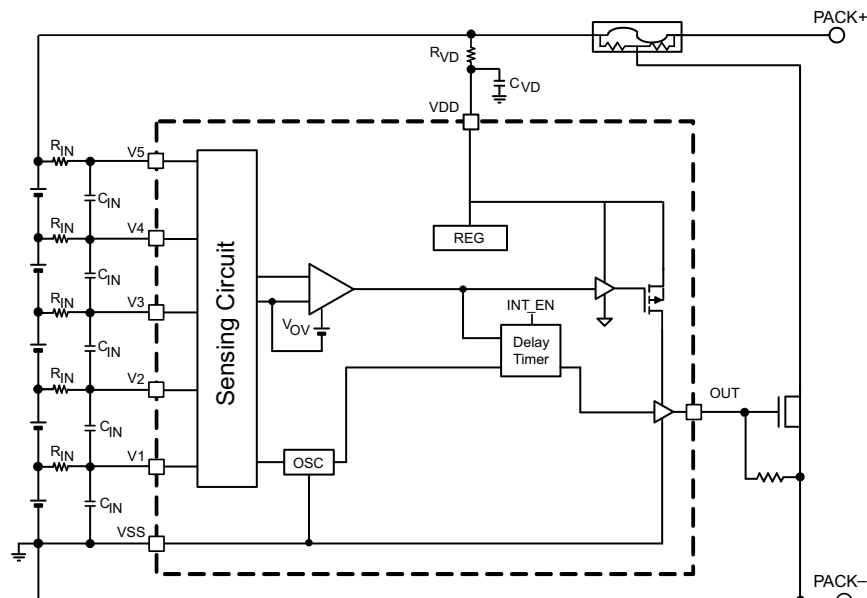

Copyright © 2016, Texas Instruments Incorporated

概略回路図



Table of Contents

1 特長.....	1	8.4 Device Functional Modes.....	10
2 アプリケーション.....	1	9 Application and Implementation.....	12
3 概要.....	1	9.1 Application Information.....	12
4 Revision History.....	2	9.2 Systems Examples.....	15
5 Device Comparison Table.....	3	10 Power Supply Recommendations.....	15
6 Pin Configuration and Functions.....	4	11 Layout.....	16
7 Specifications.....	5	11.1 Layout Guidelines.....	16
7.1 Absolute Maximum Ratings.....	5	11.2 Layout Example.....	16
7.2 ESD Ratings.....	5	12 Device and Documentation Support.....	17
7.3 Recommended Operating Conditions.....	5	12.1 Documentation Support.....	17
7.4 Thermal Information.....	5	12.2 Third-Party Products Disclaimer.....	17
7.5 DC Characteristics.....	6	12.3 Receiving Notification of Documentation Updates..	17
7.6 Timing Requirements.....	7	12.4 サポート・リソース.....	17
7.7 Typical Characteristics.....	8	12.5 Trademarks.....	17
8 Detailed Description.....	9	12.6 Electrostatic Discharge Caution.....	17
8.1 Overview.....	9	12.7 Glossary.....	17
8.2 Functional Block Diagram.....	9	13 Mechanical, Packaging, and Orderable	
8.3 Feature Description.....	9	Information.....	17

4 Revision History

資料番号末尾の英字は改訂を表しています。その改訂履歴は英語版に準じています。

Changes from Revision K (April 2021) to Revision L (June 2021)	Page
• Changed the BQ771825 device to Production Data.....	3

Changes from Revision J (September 2020) to Revision K (June 2021)	Page
• Added the BQ771825 device to the Device Comparison Table	3

Changes from Revision I (July 2020) to Revision J (September 2020)	Page
• Added the BQ771824 device to the Device Comparison Table	3
• Added BQ771824 to the DC Characteristics	6
• Added BQ771824 delay settings.....	7

Changes from Revision H (February 2020) to Revision I (July 2020)	Page
• 機能安全対応機能を追加.....	1
• Added the BQ771823 device to the Device Comparison Table	3
• Added BQ771823 to the DC Characteristics	6
• Added BQ771823 delay settings to セクション 7.6	7

5 Device Comparison Table

T _A	Part Number	Package	Package Designator	OVP (V)	OV Hysteresis (V)	Output Delay	Output Drive	Tape and Reel (Large)	Tape and Reel (Small)
-40°C to 110°C	BQ771800	8-Pin QFN or 8-Pin MSOP	DPJ/DGK	4.300	0.300	4 s	CMOS Active High	BQ771800DPJR	BQ771800DPJT
	BQ771801			4.275	0.050	3 s	NCH Active Low, Open Drain	BQ771801DPJR	BQ771801DPJT
	BQ771802			4.225	0.300	1 s	NCH Active Low, Open Drain	BQ771802DPJR	BQ771802DPJT
	BQ771803			4.275	0.050	1 s	NCH Active Low, Open Drain	BQ771803DPJR BQ771803DGKR ⁽²⁾	BQ771803DPJT BQ771803DGKT ⁽²⁾
	BQ771806			4.350	0.300	3 s	CMOS Active High	BQ771806DPJR	BQ771806DPJT
	BQ771807			4.450	0.300	3 s	CMOS Active High	BQ771807DPJR	BQ771807DPJT
	BQ771808			4.200	0.050	1 s	NCH Active Low, Open Drain	BQ771808DPJR	BQ771808DPJT
	BQ771809			4.200	0.050	1 s	CMOS Active High	BQ771809DPJR	BQ771809DPJT
	BQ771811			4.225	0.050	1 s	CMOS Active High	BQ771811DPJR	BQ771811DPJT
	BQ771815			4.225	0.050	1 s	NCH Active Low, Open Drain	BQ771815DPJR	BQ771815DPJT
	BQ771817			4.275	0.050	1 s	CMOS Active High	BQ771817DPJR	BQ771817DPJT
	BQ771818			4.300	0.300	1 s	CMOS Active High	BQ771818DPJR BQ771818DGKR	BQ771818DPJT BQ771818DGKT
	BQ771823			4.275	0.300	3 s	NCH Active Low, Open Drain	BQ771823DPJR	—
	BQ771824			3.850	0.300	4 s	CMOS Active High	BQ771824DPJR	—
	BQ771825			3.950	0.050	3 s	NCH Active Low, Open Drain	BQ771825DPJR BQ771825DGKR ⁽²⁾	BQ771825DPJT BQ771825DGKT ⁽²⁾
	BQ7718xy ⁽¹⁾			3.850 – 4.650	Latch, 0.05, 0.25, 0.3	1, 4, 3, 5.5 s	NCH, Active Low, Open Drain, CMOS Active High	BQ7718xyDPJR	BQ7718xyDPJT

- (1) Future option. Contact TI for more information.
(2) Contact TI for more information.

6 Pin Configuration and Functions



图 6-1. DPJ Package 8-Pin (WSO) Top View



图 6-2. DGK Package 8-Pin (PDSO) Top View

表 6-1. Pin Functions

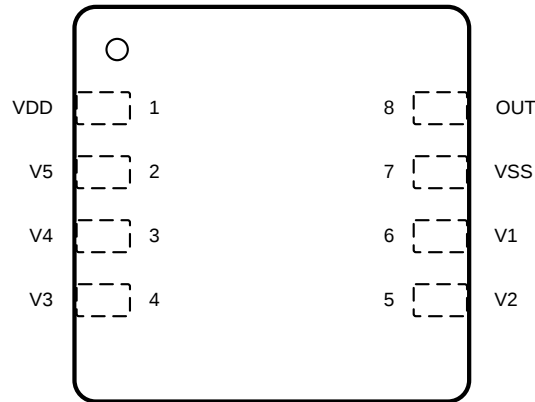
NO.	NAME	TYPE I/O	DESCRIPTION
1	VDD	P	Power supply
2	V5	I	Sense input for positive voltage of the fifth cell from the bottom of the stack
3	V4	I	Sense input for positive voltage of the fourth cell from the bottom of the stack
4	V3	I	Sense input for positive voltage of the third cell from the bottom of the stack
5	V2	I	Sense input for positive voltage of the second cell from the bottom of the stack
6	V1	I	Sense input for positive voltage of the lowest cell in the stack
7	VSS	P	Electrically connected to IC ground and negative terminal of the lowest cell in the stack
8	OUT	O	Output drive for overvoltage fault signal

O = Output, I = Input, P = Power connection

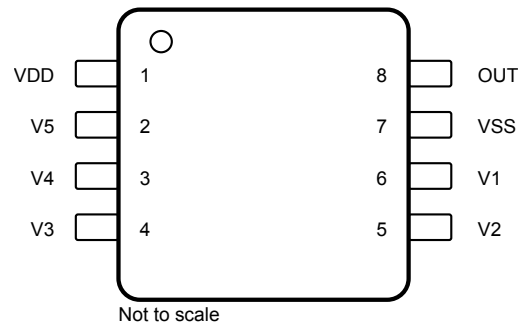
7 Specifications

7.1 Absolute Maximum Ratings

Over-operating free-air temperature range (unless otherwise noted)⁽¹⁾

		MIN	MAX	UNIT
Supply voltage range	VDD – VSS	–0.3	30	V
Input voltage range	V5 – VSS or V4 – VSS or V3 – VSS or V2 – VSS or V1 – VSS	–0.3	30	V
Output voltage range	OUT – VSS	–0.3	30	V
Continuous total power dissipation, P _{TOT}		See セクション 7.4 .		
Functional temperature		–40	110	°C
Storage temperature range, T _{STG}		–65	150	°C

- (1) Stresses beyond those listed under “absolute maximum ratings” may cause permanent damage to the device. These are stress ratings only and functional operation of the device at these or any other conditions beyond those indicated under “recommended operating conditions” is not implied. Exposure to absolute-maximum-rated conditions for extended periods may affect device reliability.

7.2 ESD Ratings

			VALUE	UNIT
V _(ESD) Rating	Electrostatic discharge	Human body model (HBM) ESD stress voltage ⁽¹⁾	±2000	V
		Charged device model (CDM) ESD stress voltage ⁽²⁾	±500	

- (1) JEDEC document JEP155 states that 500-V HBM allows safe manufacturing with a standard ESD control process.
(2) JEDEC document JEP157 states that 250-V CDM allows safe manufacturing with a standard ESD control process.

7.3 Recommended Operating Conditions

Over-operating free-air temperature range (unless otherwise noted)

		MIN	MAX	UNIT
Supply voltage, V _{DD}	⁽¹⁾	3	25	V
Input voltage range	V5–V4 or V4–V3 or V3–V2 or V2–V1 or V1–VSS	0	5	V
Operating ambient temperature range, T _A		–40	110	°C

- (1) See [セクション 9.2](#).

7.4 Thermal Information

THERMAL METRIC ⁽¹⁾		BQ7718xy		UNIT
		DPJ (WSON)		
		8 PINS		
R _{θJA}	Junction-to-ambient thermal resistance	56.6		°C/W
R _{θJCTop}	Junction-to-case(top) thermal resistance	56.4		°C/W
R _{θJB}	Junction-to-board thermal resistance	30.6		°C/W
ψ _{JT}	Junction-to-top characterization parameter	1.0		°C/W
ψ _{JB}	Junction-to-board characterization parameter	37.8		°C/W
R _{θJCbott}	Junction-to-case(bottom) thermal resistance	11.3		°C/W

- (1) For more information about traditional and new thermal metrics, see the [Semiconductor and IC Package Thermal Metrics](#) application report.

7.5 DC Characteristics

Typical values stated where $T_A = 25^\circ\text{C}$ and $V_{DD} = 18\text{ V}$, MIN/MAX values stated where $T_A = -40^\circ\text{C}$ to 110°C and $V_{DD} = 3\text{ V}$ to 25 V (unless otherwise noted).

SYMBOL	PARAMETER	CONDITION	MIN	TYP	MAX	UNIT
Voltage Protection Threshold VCx						
V_{OV}	$V_{(PROTECT)}$ Overvoltage Detection	BQ771800		4.300		V
		BQ771801		4.275		V
		BQ771803		4.275		V
		BQ771802		4.225		V
		BQ771806		4.350		V
		BQ771807		4.450		V
		BQ771808		4.200		V
		BQ771809		4.200		V
		BQ771811		4.225		V
		BQ771815		4.225		V
		BQ771817		4.275		V
		BQ771818		4.300		V
		BQ771823		4.275		V
BQ771824		3.850		V		
V_{HYS}	OV Detection Hysteresis	BQ771800	250	300	400	mV
		BQ771801	0	50	100	mV
		BQ771802	250	300	400	mV
		BQ771803	0	50	100	mV
		BQ771806	250	300	400	mV
		BQ771807	250	300	400	mV
		BQ771808	0	50	100	mV
		BQ771809	0	50	100	mV
		BQ771811	0	50	100	mV
		BQ771815	0	50	100	mV
		BQ771817	0	50	100	mV
		BQ771818	250	300	400	mV
		BQ771823	250	300	400	mV
BQ771824	250	300	400	mV		
V_{OA}	OV Detection Accuracy	$T_A = 25^\circ\text{C}$	-10		10	mV
$V_{OADRIFT}$	OV Detection Accuracy Across Temperature	$T_A = -40^\circ\text{C}$	-40		44	mV
		$T_A = 0^\circ\text{C}$	-20		20	mV
		$T_A = 60^\circ\text{C}$	-24		24	mV
		$T_A = 110^\circ\text{C}$	-54		54	mV
Supply and Leakage Current						
I_{CC}	Supply Current	$(V_5-V_4) = (V_4-V_3) = (V_3-V_2) = (V_2-V_1) = (V_1-V_{SS}) = 4\text{ V}$ (See 8-2 .)		1	2	μA
I_{IN}	Input Current at Vx Pins	$(V_5-V_4) = (V_4-V_3) = (V_3-V_2) = (V_2-V_1) = (V_1-V_{SS}) = 4\text{ V}$ (See 8-2 .)	-0.1		0.1	μA

Typical values stated where $T_A = 25^\circ\text{C}$ and $V_{DD} = 18\text{ V}$, MIN/MAX values stated where $T_A = -40^\circ\text{C}$ to 110°C and $V_{DD} = 3\text{ V}$ to 25 V (unless otherwise noted).

SYMBOL	PARAMETER	CONDITION	MIN	TYP	MAX	UNIT
Output Drive OUT, CMOS Active HIGH Versions Only						
V_{OUT1}	Output Drive Voltage, Active High	$(V5-V4)$, $(V4-V3)$, $(V3-V2)$, $(V2-V1)$, or $(V1-VSS) > V_{OV}$, $V_{DD} = 18\text{ V}$, $I_{OH} = 100\ \mu\text{A}$	6			V
		If three of four cells are short circuited and only one cell remains powered and $> V_{OV}$, $V_{DD} = V_x$ (cell voltage), $I_{OH} = 100\ \mu\text{A}$		$V_{DD} - 0.3$		V
		$(V5-V4)$, $(V4-V3)$, $(V3-V2)$, $(V2-V1)$, and $(V1-VSS) < V_{OV}$, $V_{DD} = 18\text{ V}$, $I_{OL} = 100\ \mu\text{A}$ measured into pin		250	400	mV
I_{OUTH1}	OUT Source Current (during OV)	$(V5-V4)$, $(V4-V3)$, $(V3-V2)$, $(V2-V1)$, or $(V1-VSS) > V_{OV}$, $V_{DD} = 18\text{ V}$. OUT = 0 V. Measured out of OUT pin			4.5	mA
I_{OUTL1}	OUT Sink Current (no OV)	$(V5-V4)$, $(V4-V3)$, $(V3-V2)$, $(V2-V1)$, and $(V1-VSS) < V_{OV}$, $V_{DD} = 18\text{ V}$, OUT = VDD. Measured into OUT pin	0.5		14	mA
Output Drive OUT, NCH Open Drain Active LOW Versions Only						
V_{OUT2}	Output Drive Voltage, Active Low	$(V5-V4)$, $(V4-V3)$, $(V3-V2)$, $(V2-V1)$, or $(V1-VSS) > V_{OV}$, $V_{DD} = 18\text{ V}$, $I_{OL} = 100\ \mu\text{A}$ measured into OUT pin		250	400	mV
I_{OUTH2}	OUT Sink Current (during OV)	$(V5-V4)$, $(V4-V3)$, $(V3-V2)$, $(V2-V1)$, or $(V1-VSS) > V_{OV}$, $V_{DD} = 18\text{ V}$. OUT = VDD. Measured into OUT pin	0.5		14	mA
I_{OUTL2}	OUT Source Current (no OV)	$(V5-V4)$, $(V4-V3)$, $(V3-V2)$, $(V2-V1)$, and $(V1-VSS) < V_{OV}$, $V_{DD} = 18\text{ V}$. OUT = VDD. Measured out of OUT pin			100	nA

7.6 Timing Requirements

			MIN	NOM	MAX	UNIT
Delay Timer						
t_{DELAY}	OV Delay Time	BQ771800, BQ771824	3.2	4	4.8	s
		BQ771801, BQ771807, BQ771823	2.4	3	3.6	s
		BQ771802, BQ771803, BQ771811, BQ771815, BQ771818	0.8	1	1.2	s
		Preview option only. Contact TI.	4.4	5.5	6.6	s
$X_{CTMDELAY}$	Fault Detection Delay Time during Customer Test Mode	See セクション 8.4.3 .		15		ms

7.7 Typical Characteristics

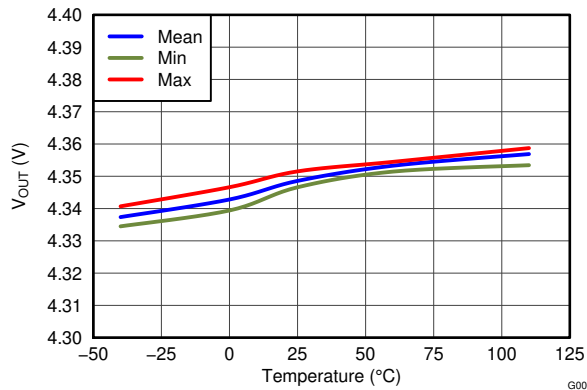

7-1. Overvoltage Threshold (OVT) vs. Temperature

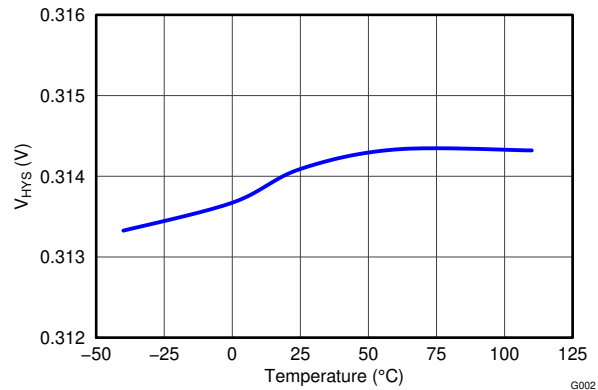

7-2. Hysteresis V_{HYS} vs. Temperature

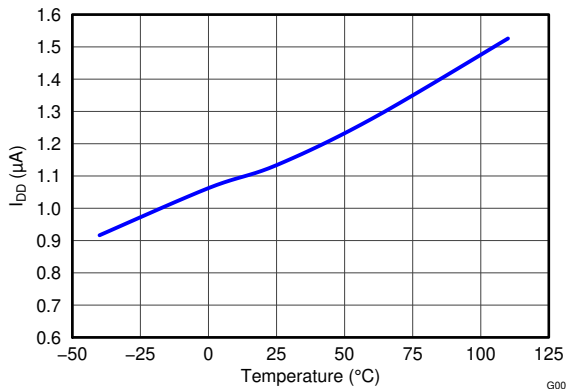

7-3. I_{DD} Current Consumption vs. Temperature at $V_{DD} = 16\text{ V}$

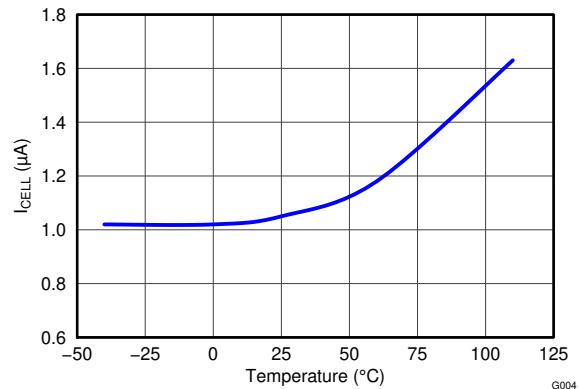

7-4. I_{CELL} vs. Temperature at $V_{CELL} = 9.2\text{ V}$

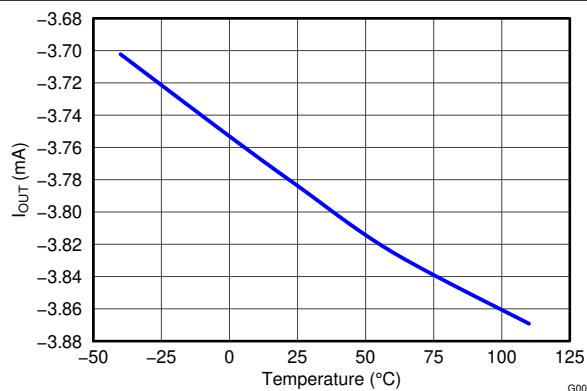

7-5. Output Current I_{OUT} vs. Temperature

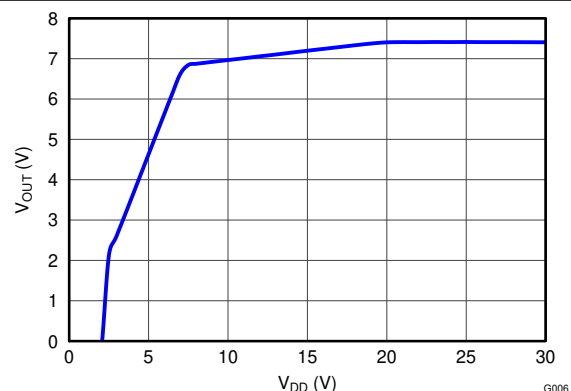

7-6. V_{OUT} vs. V_{DD}

8 Detailed Description

8.1 Overview

In the BQ7718xy family of devices, each cell is monitored independently and an external delay timer is initiated if an overvoltage condition is detected on any cell.

For quicker production-line testing, the device provides a Customer Test Mode with greatly reduced delay time.

8.2 Functional Block Diagram

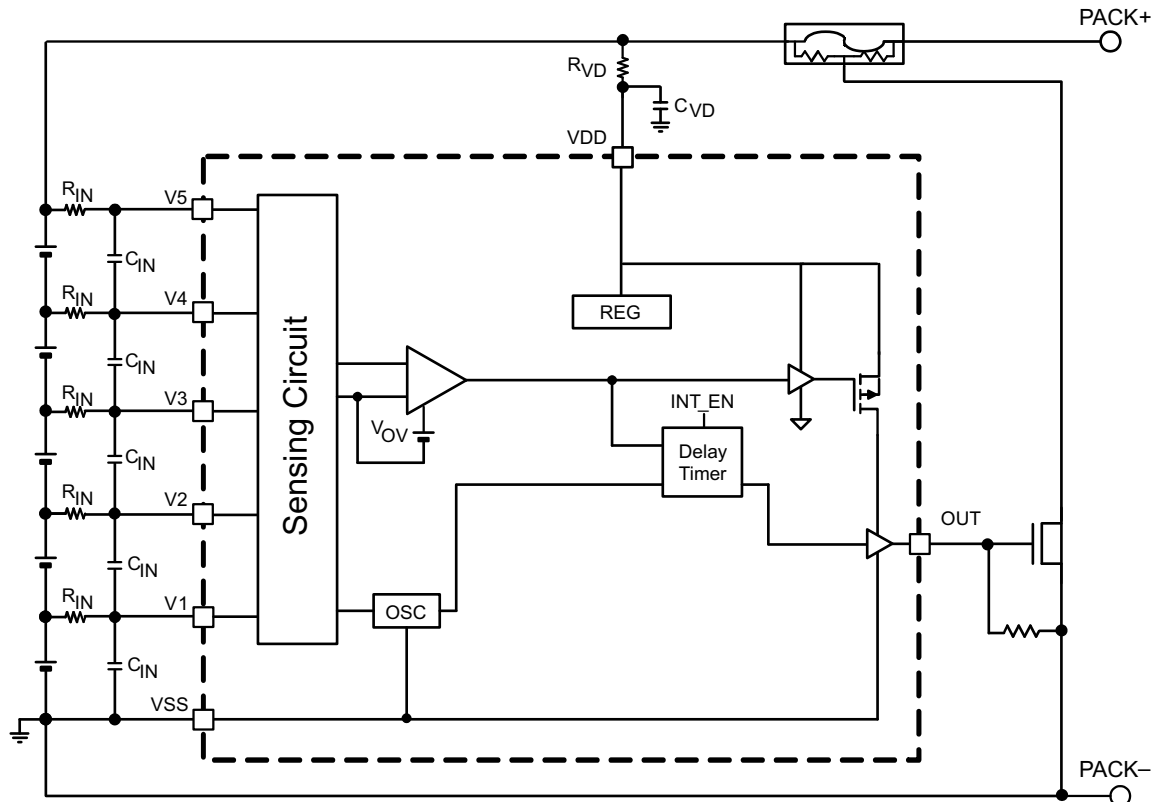

Copyright © 2016, Texas Instruments Incorporated

8.3 Feature Description

In the BQ7718xy device, each cell is monitored independently. Overvoltage is detected by comparing the actual cell voltage to a protection voltage reference, V_{OV} . If any cell voltage exceeds the programmed OV value, a timer circuit is activated. When the timer expires, the OUT pin goes from inactive to active state.

For NCH Open Drain Active Low configurations, the OUT pin pulls down to VSS when active (OV present) and is high impedance when inactive (no OV).

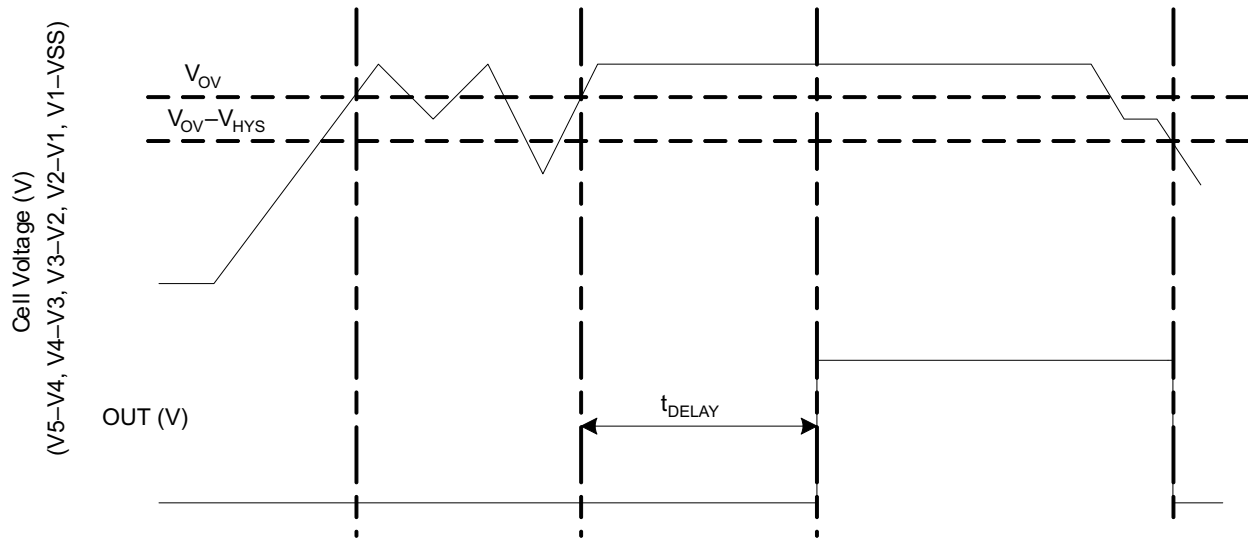

8-1. Timing for Overvoltage Sensing

8.3.1 Sense Positive Input for V_x

This is an input to sense each single battery cell voltage. A series resistor and a capacitor across the cell for each input is required for noise filtering and stable voltage monitoring.

8.3.2 Output Drive, OUT

This pin serves as the fault signal output, and may be ordered in either active HIGH or LOW options.

8.3.3 Supply Input, VDD

This pin is the unregulated input power source for the IC. A series resistor is connected to limit the current, and a capacitor is connected to ground for noise filtering.

8.4 Device Functional Modes

8.4.1 NORMAL Mode

When all of the cell voltages are below the overvoltage threshold, V_{OV} , the device operates in NORMAL mode. The device monitors the differential cell voltages connected across $(V1 - VSS)$, $(V2 - V1)$, $(V3 - V2)$, $(V4 - V3)$, and $(VC4 - VC5)$. The OUT pin is inactive and if configured:

The OUT pin is inactive and if configured:

- Active high is low.
- Active low is being externally pulled up and is an open drain.

8.4.2 OVERVOLTAGE Mode

OVERVOLTAGE mode is detected if any of the cell voltages exceeds the overvoltage threshold, V_{OV} for configured OV delay time. The OUT pin is activated after a delay time set by the capacitance in the CD pin. The OUT pin will either pull high internally, if configured as active high, or will be pulled low internally, if configured as active low. When all of the cell voltages fall below the $(V_{OV} - V_{HYS})$, the device returns to NORMAL mode.

8.4.3 Customer Test Mode

Customer Test Mode (CTM) helps to reduce test time for checking the overvoltage delay timer parameter once the circuit is implemented in the battery pack. To enter CTM, VDD should be set to at least 10 V higher than V5 (see 8-2). The delay timer is greater than 10 ms, but considerably shorter than the timer delay in normal operation. To exit Customer Test Mode, remove the VDD to a V5 voltage differential of 10 V so that the decrease in this value automatically causes an exit.

CAUTION

Avoid exceeding any Absolute Maximum Voltages on any pins when placing the part into Customer Test Mode. Also avoid exceeding Absolute Maximum Voltages for the individual cell voltages (V5–V4), (V4–V3), (V3–V2), (V2–V1), and (V1–VSS). Stressing the pins beyond the rated limits may cause permanent damage to the device.

Figure 8-2 shows the timing for the Customer Test Mode.

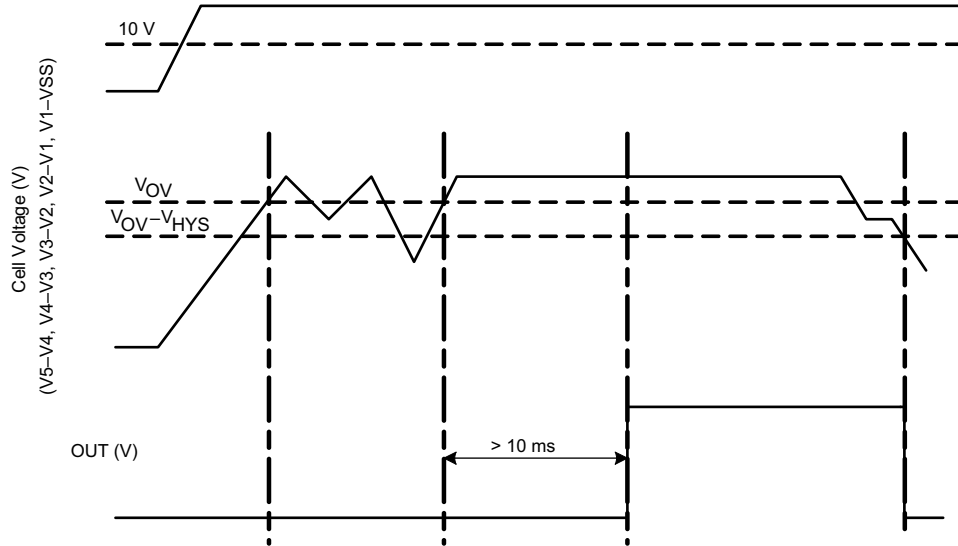

Figure 8-2. Timing for Customer Test Mode

9 Application and Implementation

Note

Information in the following applications sections is not part of the TI component specification, and TI does not warrant its accuracy or completeness. TI's customers are responsible for determining suitability of components for their purposes. Customers should validate and test their design implementation to confirm system functionality.

9.1 Application Information

In the case of an Open Drain Active Low configuration, an external pull-up resistor is required on the OUT pin. Changes to the ranges stated in 表 9-1 will impact the accuracy of the cell measurements.

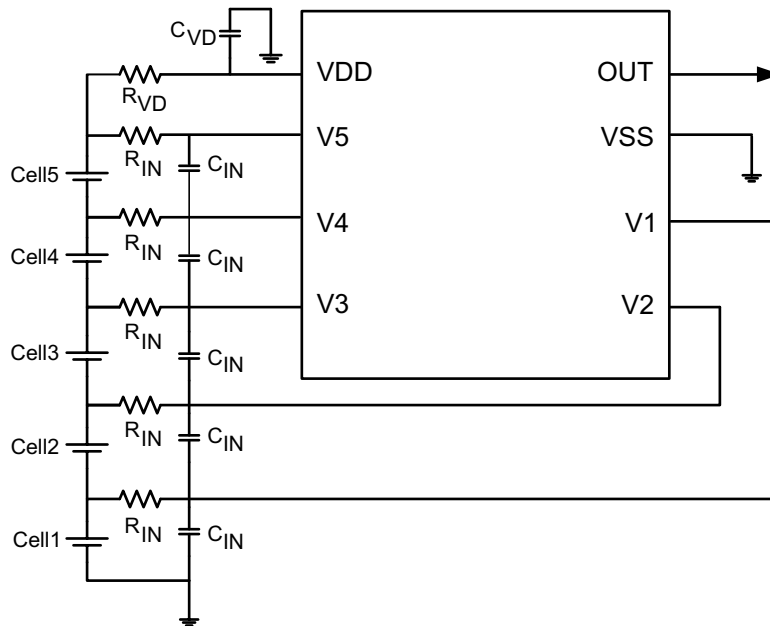

Copyright © 2016, Texas Instruments Incorporated

图 9-1. Application Configuration

9.1.1 Design Requirements

Changes to the ranges stated in 表 9-1 will impact the accuracy of the cell measurements. 图 9-1 shows each external component.

表 9-1. Parameters

PARAMETER	EXTERNAL COMPONENT	MIN	NOM	MAX	UNIT
Voltage monitor filter resistance	R_{IN}	900	1000	1100	Ω
Voltage monitor filter capacitance	C_{IN}	0.01		0.1	μF
Supply voltage filter resistance	R_{VD}	100		1K	Ω
Supply voltage filter capacitance	C_{VD}		0.1		μF
CD external delay capacitance			0.1	1	μF
OUT Open drain version pull-up resistance to PACK+			100		k Ω

Note

The device is calibrated using an R_{IN} value = 1 k Ω . Using a value other than this recommended value changes the accuracy of the cell voltage measurements and V_{OV} trigger level.

9.1.2 Detailed Design Procedure

Figure 9-2 shows the measurement for current consumption for the product for both VDD and V_x .

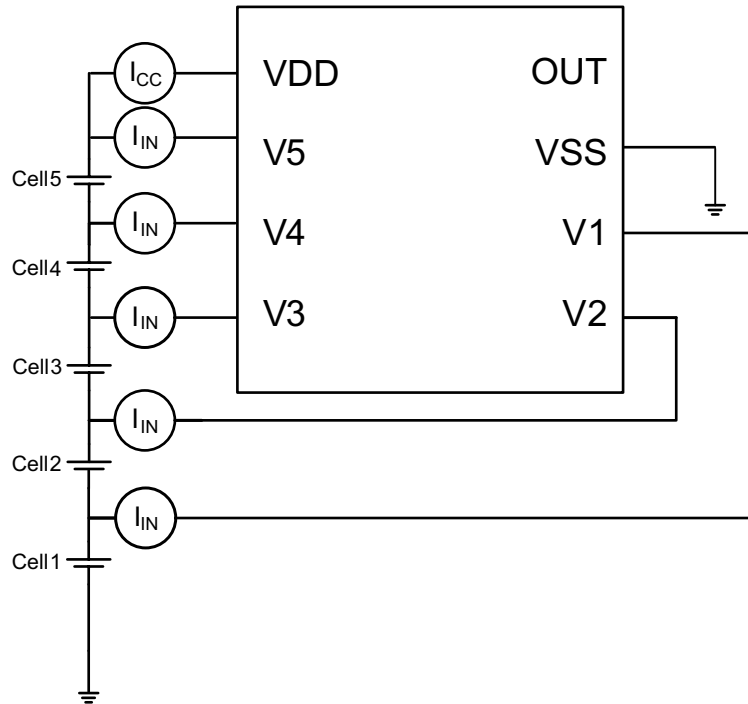

Copyright © 2016, Texas Instruments Incorporated

Figure 9-2. Configuration for IC Current Consumption Test

9.1.2.1 Application Curves

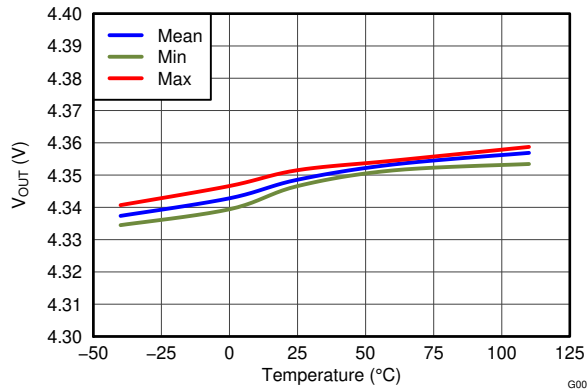

9-3. Overvoltage Threshold (OVT) vs. Temperature

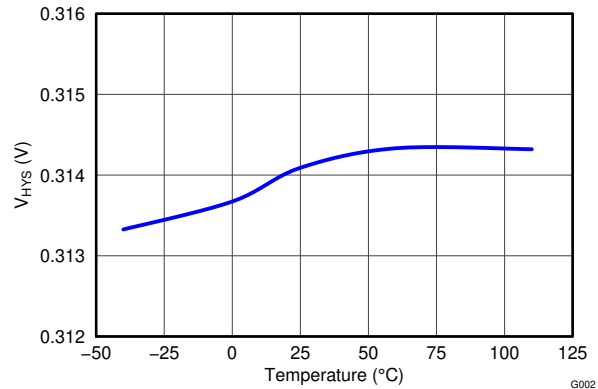

9-4. Hysteresis V_{HYS} vs. Temperature

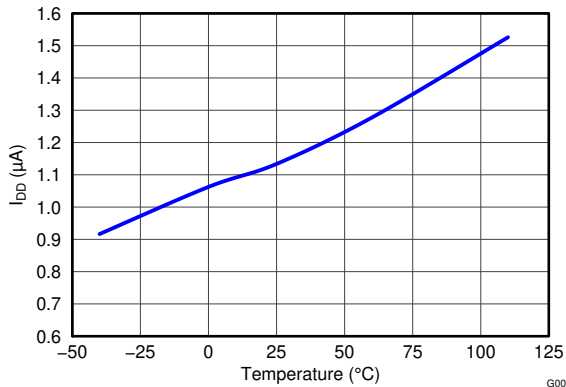

9-5. I_{DD} Current Consumption vs. Temperature at $V_{DD} = 16\text{ V}$

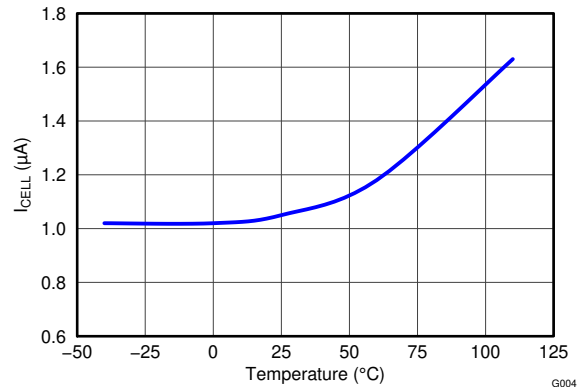

9-6. I_{CELL} vs. Temperature at $V_{CELL} = 9.2\text{ V}$

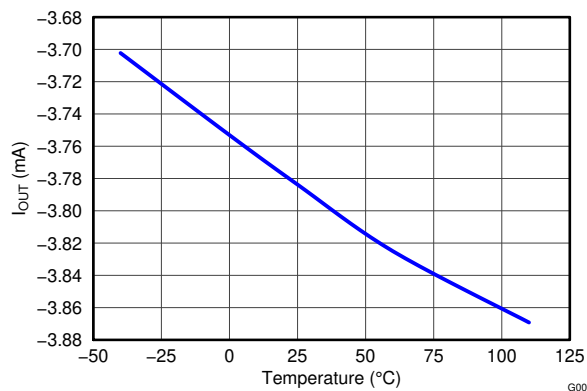

9-7. Output Current I_{OUT} vs. Temperature

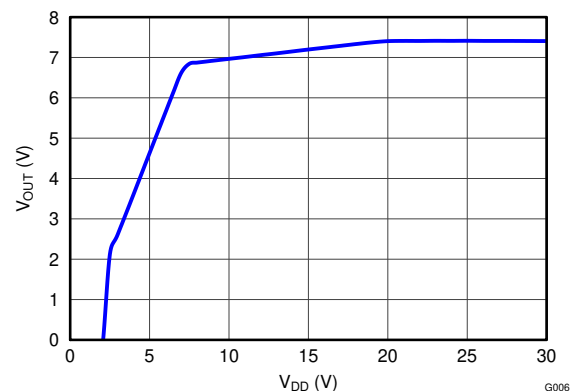

9-8. V_{OUT} vs. V_{DD}

9.2 Systems Examples

In these application examples, an external pull-up resistor is required on the OUT pin to configure for an Open Drain Active Low operation.

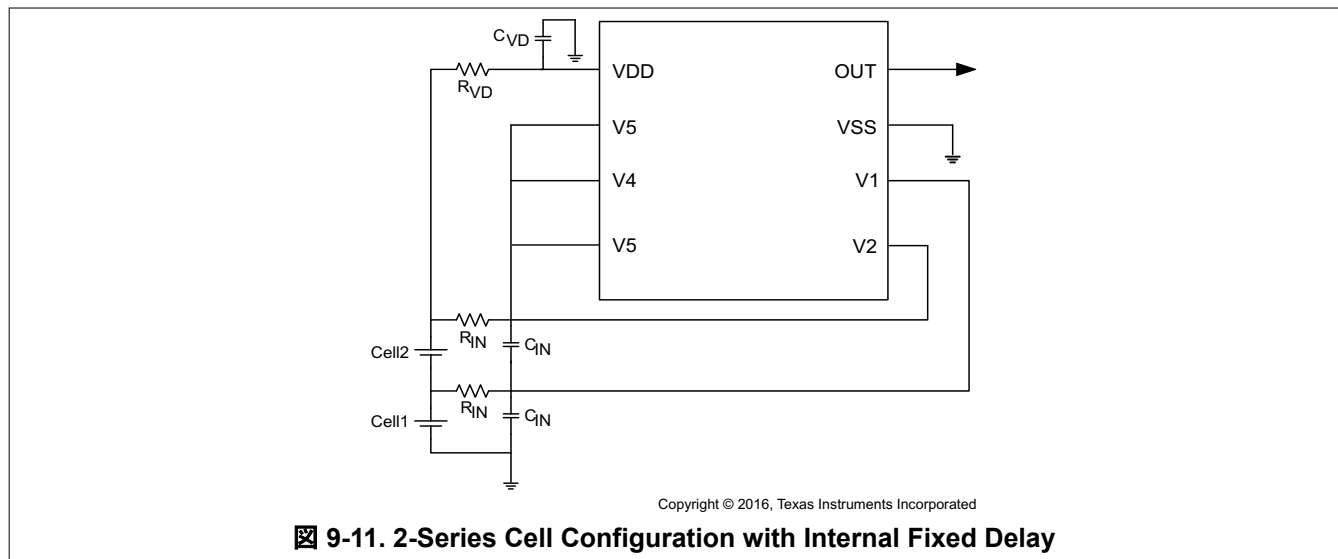
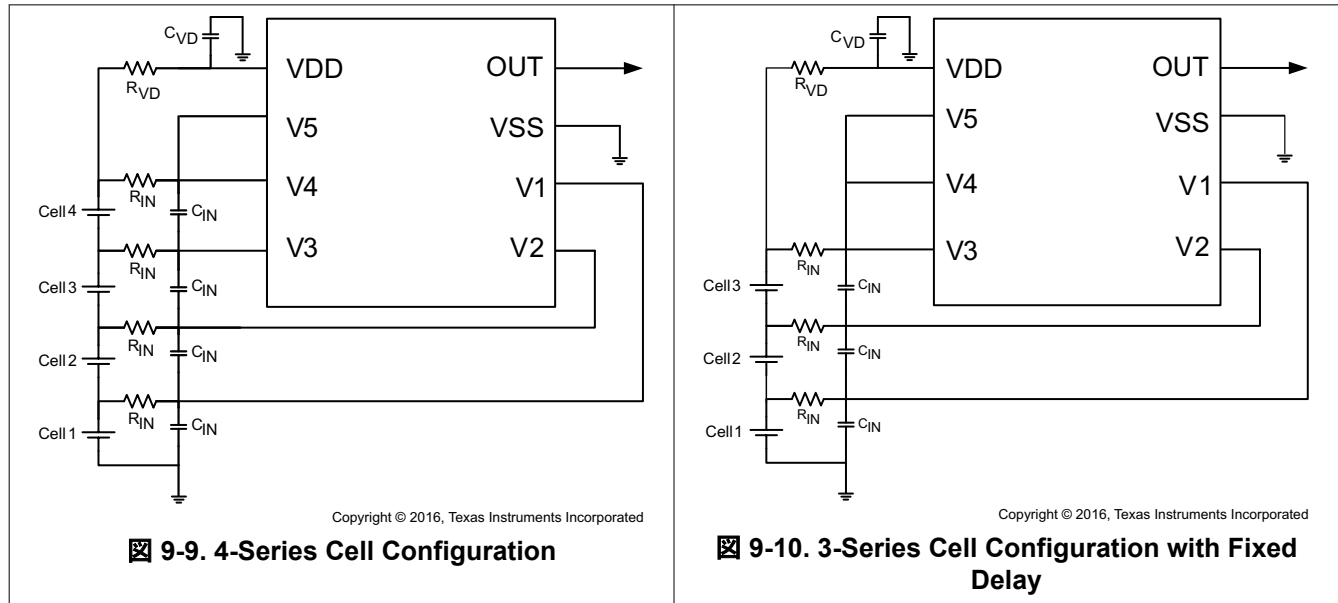

10 Power Supply Recommendations

The maximum power of this device is 25 V on VDD.

11 Layout

11.1 Layout Guidelines

- Ensure the RC filters for the V1 and VDD pins are placed as close as possible to the target terminal.
- The VSS pin should be routed to the CELL– terminal.

11.2 Layout Example

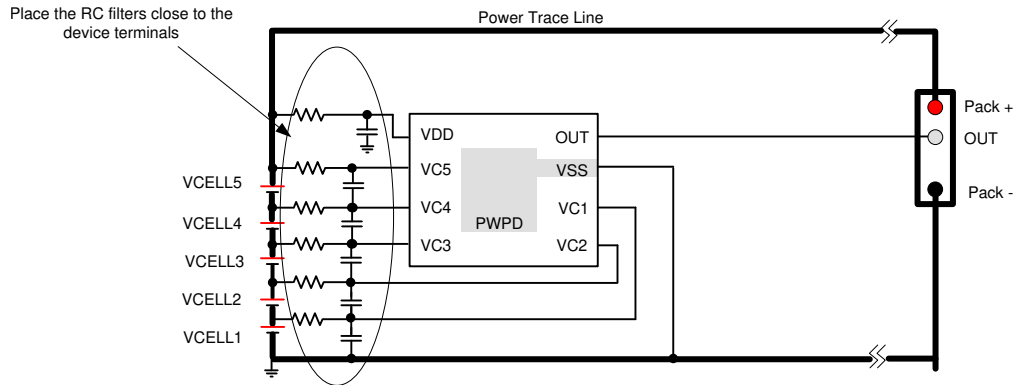

☒ 11-1. Example Layout

12 Device and Documentation Support

12.1 Documentation Support

For additional information, see the [BQ7718 technical documentation](#), including the documentation available to aid functional safety system design.

12.2 Third-Party Products Disclaimer

TI'S PUBLICATION OF INFORMATION REGARDING THIRD-PARTY PRODUCTS OR SERVICES DOES NOT CONSTITUTE AN ENDORSEMENT REGARDING THE SUITABILITY OF SUCH PRODUCTS OR SERVICES OR A WARRANTY, REPRESENTATION OR ENDORSEMENT OF SUCH PRODUCTS OR SERVICES, EITHER ALONE OR IN COMBINATION WITH ANY TI PRODUCT OR SERVICE.

12.3 Receiving Notification of Documentation Updates

To receive notification of documentation updates, navigate to the device product folder on [ti.com](#). Click on *Subscribe to updates* to register and receive a weekly digest of any product information that has changed. For change details, review the revision history included in any revised document.

12.4 サポート・リソース

[TI E2E™ サポート・フォーラム](#)は、エンジニアが検証済みの回答と設計に関するヒントをエキスパートから迅速かつ直接得ることができる場所です。既存の回答を検索したり、独自の質問をしたりすることで、設計に必要な支援を迅速に得ることができます。

リンクされているコンテンツは、該当する貢献者により、現状のまま提供されるものです。これらは TI の仕様を構成するものではなく、必ずしも TI の見解を反映したものではありません。TI の[使用条件](#)を参照してください。

12.5 Trademarks

TI E2E™ is a trademark of Texas Instruments.

すべての商標は、それぞれの所有者に帰属します。

12.6 Electrostatic Discharge Caution



This integrated circuit can be damaged by ESD. Texas Instruments recommends that all integrated circuits be handled with appropriate precautions. Failure to observe proper handling and installation procedures can cause damage.

ESD damage can range from subtle performance degradation to complete device failure. Precision integrated circuits may be more susceptible to damage because very small parametric changes could cause the device not to meet its published specifications.

12.7 Glossary

[TI Glossary](#) This glossary lists and explains terms, acronyms, and definitions.

13 Mechanical, Packaging, and Orderable Information

The following pages include mechanical, packaging, and orderable information. This information is the most current data available for the designated devices. This data is subject to change without notice and revision of this document. For browser-based versions of this data sheet, refer to the left-hand navigation.

PACKAGING INFORMATION

Orderable Device	Status (1)	Package Type	Package Drawing	Pins	Package Qty	Eco Plan (2)	Lead finish/ Ball material (6)	MSL Peak Temp (3)	Op Temp (°C)	Device Marking (4/5)	Samples
BQ771800DPJR	ACTIVE	WSO	DPJ	8	3000	RoHS & Green	NIPDAU	Level-1-260C-UNLIM	-40 to 85	771800	Samples
BQ771800DPJT	ACTIVE	WSO	DPJ	8	250	RoHS & Green	NIPDAU	Level-1-260C-UNLIM	-40 to 85	771800	Samples
BQ771801DPJR	ACTIVE	WSO	DPJ	8	3000	RoHS & Green	NIPDAU	Level-1-260C-UNLIM	-40 to 85	771801	Samples
BQ771801DPJT	ACTIVE	WSO	DPJ	8	250	RoHS & Green	NIPDAU	Level-1-260C-UNLIM	-40 to 85	771801	Samples
BQ771802DPJR	ACTIVE	WSO	DPJ	8	3000	RoHS & Green	NIPDAU	Level-1-260C-UNLIM	-40 to 85	771802	Samples
BQ771802DPJT	ACTIVE	WSO	DPJ	8	250	RoHS & Green	NIPDAU	Level-1-260C-UNLIM	-40 to 85	771802	Samples
BQ771803DPJR	ACTIVE	WSO	DPJ	8	3000	RoHS & Green	NIPDAU	Level-1-260C-UNLIM	-40 to 85	771803	Samples
BQ771803DPJT	ACTIVE	WSO	DPJ	8	250	RoHS & Green	NIPDAU	Level-1-260C-UNLIM	-40 to 85	771803	Samples
BQ771806DPJR	ACTIVE	WSO	DPJ	8	3000	RoHS & Green	NIPDAU	Level-1-260C-UNLIM	-40 to 85	771806	Samples
BQ771806DPJT	ACTIVE	WSO	DPJ	8	250	RoHS & Green	NIPDAU	Level-1-260C-UNLIM	-40 to 85	771806	Samples
BQ771807DPJR	ACTIVE	WSO	DPJ	8	3000	RoHS & Green	NIPDAU	Level-1-260C-UNLIM	-40 to 85	771807	Samples
BQ771807DPJT	ACTIVE	WSO	DPJ	8	250	RoHS & Green	NIPDAU	Level-1-260C-UNLIM	-40 to 85	771807	Samples
BQ771808DPJR	ACTIVE	WSO	DPJ	8	3000	RoHS & Green	NIPDAU	Level-1-260C-UNLIM	-40 to 85	771808	Samples
BQ771808DPJT	ACTIVE	WSO	DPJ	8	250	RoHS & Green	NIPDAU	Level-1-260C-UNLIM	-40 to 85	771808	Samples
BQ771809DPJR	ACTIVE	WSO	DPJ	8	3000	RoHS & Green	NIPDAU	Level-1-260C-UNLIM	-40 to 85	771809	Samples
BQ771809DPJT	ACTIVE	WSO	DPJ	8	250	RoHS & Green	NIPDAU	Level-1-260C-UNLIM	-40 to 85	771809	Samples
BQ771811DPJR	ACTIVE	WSO	DPJ	8	3000	RoHS & Green	NIPDAU	Level-1-260C-UNLIM	-40 to 85	771811	Samples
BQ771811DPJT	ACTIVE	WSO	DPJ	8	250	RoHS & Green	NIPDAU	Level-1-260C-UNLIM	-40 to 85	771811	Samples
BQ771815DPJR	ACTIVE	WSO	DPJ	8	3000	RoHS & Green	NIPDAU	Level-1-260C-UNLIM	-40 to 85	771815	Samples
BQ771815DPJT	ACTIVE	WSO	DPJ	8	250	RoHS & Green	NIPDAU	Level-1-260C-UNLIM	-40 to 85	771815	Samples

Orderable Device	Status (1)	Package Type	Package Drawing	Pins	Package Qty	Eco Plan (2)	Lead finish/ Ball material (6)	MSL Peak Temp (3)	Op Temp (°C)	Device Marking (4/5)	Samples
BQ771817DPJR	ACTIVE	WSO	DPJ	8	3000	RoHS & Green	NIPDAU	Level-1-260C-UNLIM	-40 to 85	771817	Samples
BQ771817DPJT	ACTIVE	WSO	DPJ	8	250	RoHS & Green	NIPDAU	Level-1-260C-UNLIM	-40 to 85	771817	Samples
BQ771818DPJR	ACTIVE	WSO	DPJ	8	3000	RoHS & Green	NIPDAU	Level-1-260C-UNLIM	-40 to 85	771818	Samples
BQ771818DPJT	ACTIVE	WSO	DPJ	8	250	RoHS & Green	NIPDAU	Level-1-260C-UNLIM	-40 to 85	771818	Samples
BQ771823DPJR	ACTIVE	WSO	DPJ	8	3000	RoHS & Green	NIPDAU	Level-1-260C-UNLIM	-40 to 110	771823	Samples
BQ771824DPJR	ACTIVE	WSO	DPJ	8	3000	RoHS & Green	NIPDAU	Level-1-260C-UNLIM	-40 to 110	771824	Samples
BQ771825DPJR	ACTIVE	WSO	DPJ	8	3000	RoHS & Green	NIPDAU	Level-1-260C-UNLIM	-40 to 85	771825	Samples

(1) The marketing status values are defined as follows:

ACTIVE: Product device recommended for new designs.

LIFEBUY: TI has announced that the device will be discontinued, and a lifetime-buy period is in effect.

NRND: Not recommended for new designs. Device is in production to support existing customers, but TI does not recommend using this part in a new design.

PREVIEW: Device has been announced but is not in production. Samples may or may not be available.

OBSOLETE: TI has discontinued the production of the device.

(2) **RoHS:** TI defines "RoHS" to mean semiconductor products that are compliant with the current EU RoHS requirements for all 10 RoHS substances, including the requirement that RoHS substance do not exceed 0.1% by weight in homogeneous materials. Where designed to be soldered at high temperatures, "RoHS" products are suitable for use in specified lead-free processes. TI may reference these types of products as "Pb-Free".

RoHS Exempt: TI defines "RoHS Exempt" to mean products that contain lead but are compliant with EU RoHS pursuant to a specific EU RoHS exemption.

Green: TI defines "Green" to mean the content of Chlorine (Cl) and Bromine (Br) based flame retardants meet JS709B low halogen requirements of <=1000ppm threshold. Antimony trioxide based flame retardants must also meet the <=1000ppm threshold requirement.

(3) MSL, Peak Temp. - The Moisture Sensitivity Level rating according to the JEDEC industry standard classifications, and peak solder temperature.

(4) There may be additional marking, which relates to the logo, the lot trace code information, or the environmental category on the device.

(5) Multiple Device Markings will be inside parentheses. Only one Device Marking contained in parentheses and separated by a "~" will appear on a device. If a line is indented then it is a continuation of the previous line and the two combined represent the entire Device Marking for that device.

(6) Lead finish/Ball material - Orderable Devices may have multiple material finish options. Finish options are separated by a vertical ruled line. Lead finish/Ball material values may wrap to two lines if the finish value exceeds the maximum column width.

Important Information and Disclaimer: The information provided on this page represents TI's knowledge and belief as of the date that it is provided. TI bases its knowledge and belief on information provided by third parties, and makes no representation or warranty as to the accuracy of such information. Efforts are underway to better integrate information from third parties. TI has taken and continues to take reasonable steps to provide representative and accurate information but may not have conducted destructive testing or chemical analysis on incoming materials and chemicals. TI and TI suppliers consider certain information to be proprietary, and thus CAS numbers and other limited information may not be available for release.

In no event shall TI's liability arising out of such information exceed the total purchase price of the TI part(s) at issue in this document sold by TI to Customer on an annual basis.

TAPE AND REEL INFORMATION

QUADRANT ASSIGNMENTS FOR PIN 1 ORIENTATION IN TAPE

*All dimensions are nominal

Device	Package Type	Package Drawing	Pins	SPQ	Reel Diameter (mm)	Reel Width W1 (mm)	A0 (mm)	B0 (mm)	K0 (mm)	P1 (mm)	W (mm)	Pin1 Quadrant
BQ771800DPJR	WSO	DPJ	8	3000	330.0	12.4	3.3	4.3	1.1	8.0	12.0	Q2
BQ771800DPJT	WSO	DPJ	8	250	180.0	12.4	3.3	4.3	1.1	8.0	12.0	Q2
BQ771801DPJR	WSO	DPJ	8	3000	330.0	12.4	3.3	4.3	1.1	8.0	12.0	Q2
BQ771801DPJT	WSO	DPJ	8	250	180.0	12.4	3.3	4.3	1.1	8.0	12.0	Q2
BQ771802DPJR	WSO	DPJ	8	3000	330.0	12.4	3.3	4.3	1.1	8.0	12.0	Q2
BQ771802DPJT	WSO	DPJ	8	250	180.0	12.4	3.3	4.3	1.1	8.0	12.0	Q2
BQ771803DPJR	WSO	DPJ	8	3000	330.0	12.4	3.3	4.3	1.1	8.0	12.0	Q2
BQ771803DPJT	WSO	DPJ	8	250	180.0	12.4	3.3	4.3	1.1	8.0	12.0	Q2
BQ771806DPJR	WSO	DPJ	8	3000	330.0	12.4	3.3	4.3	1.1	8.0	12.0	Q2
BQ771806DPJT	WSO	DPJ	8	250	180.0	12.4	3.3	4.3	1.1	8.0	12.0	Q2
BQ771807DPJR	WSO	DPJ	8	3000	330.0	12.4	3.3	4.3	1.1	8.0	12.0	Q2
BQ771807DPJT	WSO	DPJ	8	250	180.0	12.4	3.3	4.3	1.1	8.0	12.0	Q2
BQ771808DPJR	WSO	DPJ	8	3000	330.0	12.4	3.3	4.3	1.1	8.0	12.0	Q2
BQ771808DPJT	WSO	DPJ	8	250	180.0	12.4	3.3	4.3	1.1	8.0	12.0	Q2
BQ771809DPJR	WSO	DPJ	8	3000	330.0	12.4	3.3	4.3	1.1	8.0	12.0	Q2
BQ771809DPJT	WSO	DPJ	8	250	180.0	12.4	3.3	4.3	1.1	8.0	12.0	Q2

Device	Package Type	Package Drawing	Pins	SPQ	Reel Diameter (mm)	Reel Width W1 (mm)	A0 (mm)	B0 (mm)	K0 (mm)	P1 (mm)	W (mm)	Pin1 Quadrant
BQ771811DPJR	WSON	DPJ	8	3000	330.0	12.4	3.3	4.3	1.1	8.0	12.0	Q2
BQ771811DPJT	WSON	DPJ	8	250	180.0	12.4	3.3	4.3	1.1	8.0	12.0	Q2
BQ771815DPJR	WSON	DPJ	8	3000	330.0	12.4	3.3	4.3	1.1	8.0	12.0	Q2
BQ771815DPJT	WSON	DPJ	8	250	180.0	12.4	3.3	4.3	1.1	8.0	12.0	Q2
BQ771817DPJR	WSON	DPJ	8	3000	330.0	12.4	3.3	4.3	1.1	8.0	12.0	Q2
BQ771817DPJT	WSON	DPJ	8	250	180.0	12.4	3.3	4.3	1.1	8.0	12.0	Q2
BQ771818DPJR	WSON	DPJ	8	3000	330.0	12.4	3.3	4.3	1.1	8.0	12.0	Q2
BQ771818DPJT	WSON	DPJ	8	250	180.0	12.4	3.3	4.3	1.1	8.0	12.0	Q2
BQ771823DPJR	WSON	DPJ	8	3000	330.0	12.4	3.3	4.3	1.1	8.0	12.0	Q2
BQ771824DPJR	WSON	DPJ	8	3000	330.0	12.4	3.3	4.3	1.1	8.0	12.0	Q2
BQ771825DPJR	WSON	DPJ	8	3000	330.0	12.4	3.3	4.3	1.1	8.0	12.0	Q2

TAPE AND REEL BOX DIMENSIONS

*All dimensions are nominal

Device	Package Type	Package Drawing	Pins	SPQ	Length (mm)	Width (mm)	Height (mm)
BQ771800DPJR	WSON	DPJ	8	3000	335.0	335.0	25.0
BQ771800DPJT	WSON	DPJ	8	250	182.0	182.0	20.0
BQ771801DPJR	WSON	DPJ	8	3000	335.0	335.0	25.0
BQ771801DPJT	WSON	DPJ	8	250	182.0	182.0	20.0
BQ771802DPJR	WSON	DPJ	8	3000	335.0	335.0	25.0
BQ771802DPJT	WSON	DPJ	8	250	182.0	182.0	20.0
BQ771803DPJR	WSON	DPJ	8	3000	335.0	335.0	25.0
BQ771803DPJT	WSON	DPJ	8	250	182.0	182.0	20.0
BQ771806DPJR	WSON	DPJ	8	3000	335.0	335.0	25.0
BQ771806DPJT	WSON	DPJ	8	250	182.0	182.0	20.0
BQ771807DPJR	WSON	DPJ	8	3000	335.0	335.0	25.0
BQ771807DPJT	WSON	DPJ	8	250	182.0	182.0	20.0
BQ771808DPJR	WSON	DPJ	8	3000	335.0	335.0	25.0
BQ771808DPJT	WSON	DPJ	8	250	182.0	182.0	20.0
BQ771809DPJR	WSON	DPJ	8	3000	335.0	335.0	25.0
BQ771809DPJT	WSON	DPJ	8	250	182.0	182.0	20.0
BQ771811DPJR	WSON	DPJ	8	3000	335.0	335.0	25.0
BQ771811DPJT	WSON	DPJ	8	250	182.0	182.0	20.0

Device	Package Type	Package Drawing	Pins	SPQ	Length (mm)	Width (mm)	Height (mm)
BQ771815DPJR	WSON	DPJ	8	3000	335.0	335.0	25.0
BQ771815DPJT	WSON	DPJ	8	250	182.0	182.0	20.0
BQ771817DPJR	WSON	DPJ	8	3000	335.0	335.0	25.0
BQ771817DPJT	WSON	DPJ	8	250	182.0	182.0	20.0
BQ771818DPJR	WSON	DPJ	8	3000	346.0	346.0	33.0
BQ771818DPJT	WSON	DPJ	8	250	210.0	185.0	35.0
BQ771823DPJR	WSON	DPJ	8	3000	367.0	367.0	35.0
BQ771824DPJR	WSON	DPJ	8	3000	367.0	367.0	35.0
BQ771825DPJR	WSON	DPJ	8	3000	367.0	367.0	35.0

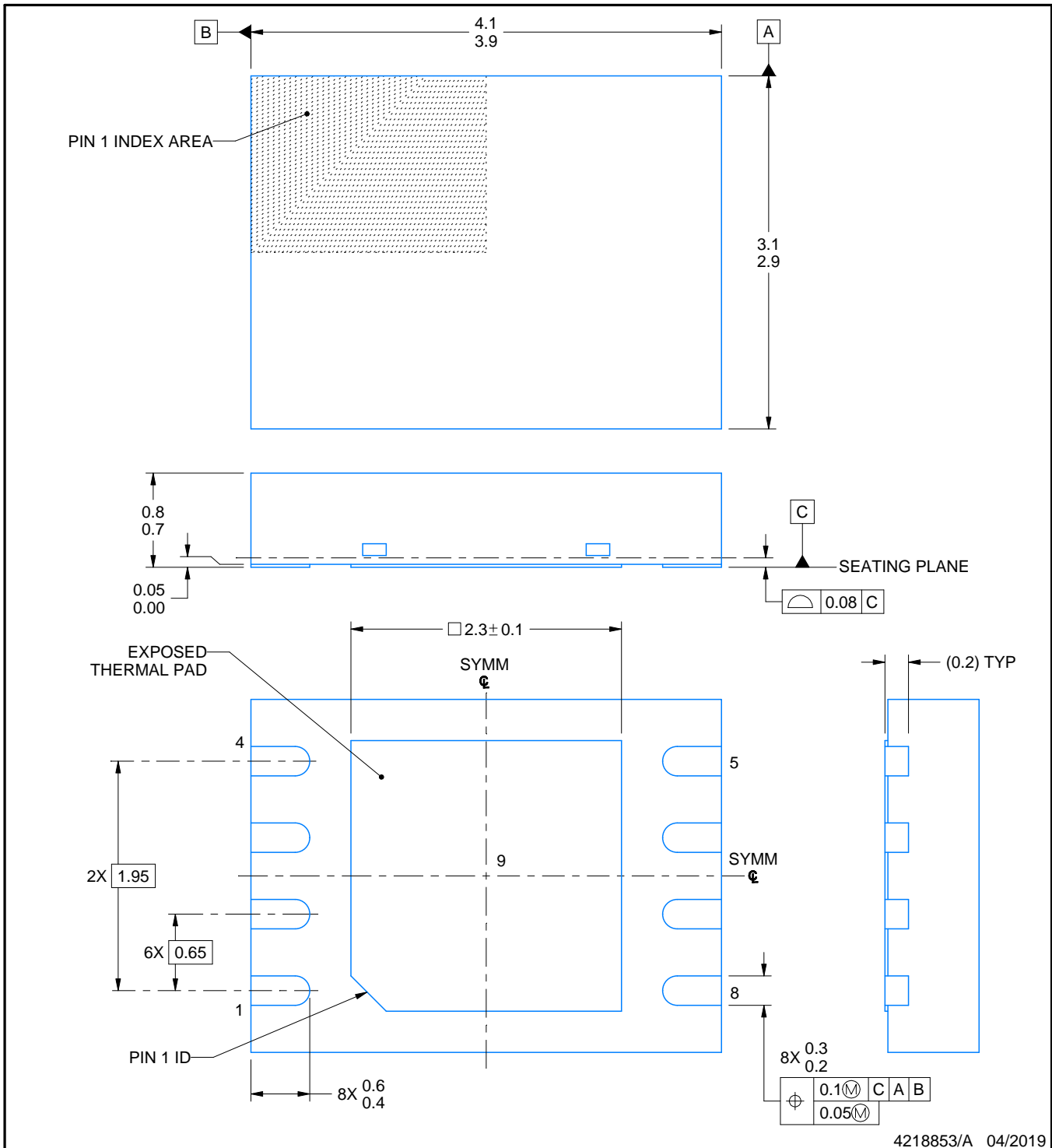
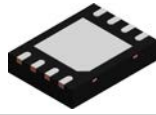

NOTES:

1. All linear dimensions are in millimeters. Any dimensions in parenthesis are for reference only. Dimensioning and tolerancing per ASME Y14.5M.
2. This drawing is subject to change without notice.
3. The package thermal pad must be soldered to the printed circuit board for thermal and mechanical performance.

EXAMPLE BOARD LAYOUT

DPJ0008A

WSON - 0.8 mm max height

PLASTIC SMALL OUTLINE - NO LEAD

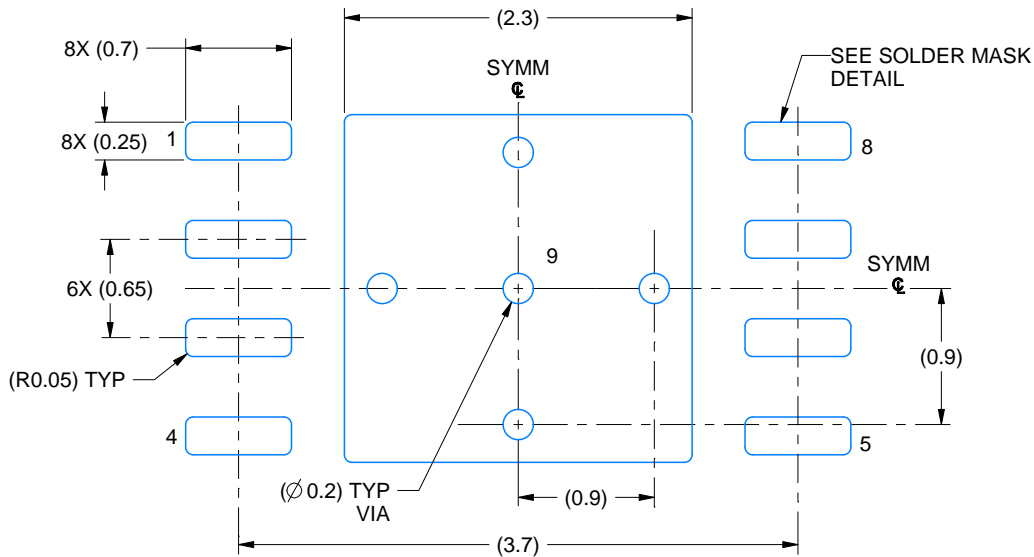

LAND PATTERN EXAMPLE
EXPOSED METAL SHOWN
SCALE: 20X

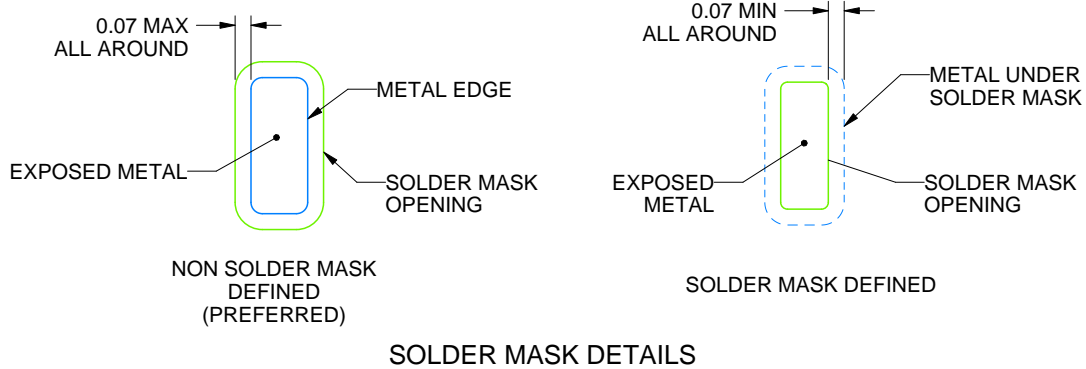

4218853/A 04/2019

NOTES: (continued)

- This package is designed to be soldered to a thermal pad on the board. For more information, see Texas Instruments literature number SLUA271 (www.ti.com/lit/slua271).
- Vias are optional depending on application, refer to device data sheet. If any vias are implemented, refer to their locations shown on this view. It is recommended that vias under paste be filled, plugged or tented.

EXAMPLE STENCIL DESIGN

DPJ0008A

WSON - 0.8 mm max height

PLASTIC SMALL OUTLINE - NO LEAD

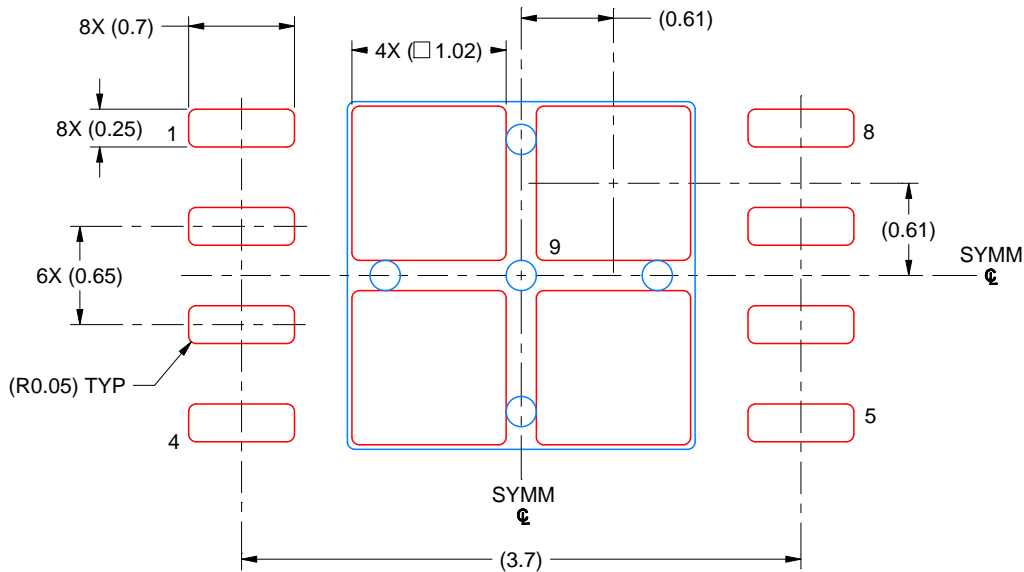

SOLDER PASTE EXAMPLE
BASED ON 0.125 MM THICK STENCIL
SCALE: 20X

EXPOSED PAD 9
79% PRINTED SOLDER COVERAGE BY AREA UNDER PACKAGE

4218853/A 04/2019

NOTES: (continued)

6. Laser cutting apertures with trapezoidal walls and rounded corners may offer better paste release. IPC-7525 may have alternate design recommendations.

重要なお知らせと免責事項

TI は、技術データと信頼性データ (データシートを含みます)、設計リソース (リファレンス・デザインを含みます)、アプリケーションや設計に関する各種アドバイス、Web ツール、安全性情報、その他のリソースを、欠陥が存在する可能性のある「現状のまま」提供しており、商品性および特定目的に対する適合性の黙示保証、第三者の知的財産権の非侵害保証を含むいかなる保証も、明示的または黙示的にかかわらず拒否します。

これらのリソースは、TI 製品を使用する設計の経験を積んだ開発者への提供を意図したものです。(1) お客様のアプリケーションに適した TI 製品の選定、(2) お客様のアプリケーションの設計、検証、試験、(3) お客様のアプリケーションに該当する各種規格や、その他のあらゆる安全性、セキュリティ、規制、または他の要件への確実な適合に関する責任を、お客様のみが単独で負うものとし、

上記の各種リソースは、予告なく変更される可能性があります。これらのリソースは、リソースで説明されている TI 製品を使用するアプリケーションの開発の目的でのみ、TI はその使用をお客様に許諾します。これらのリソースに関して、他の目的で複製することや掲載することは禁止されています。TI や第三者の知的財産権のライセンスが付与されている訳ではありません。お客様は、これらのリソースを自身で使用した結果発生するあらゆる申し立て、損害、費用、損失、責任について、TI およびその代理人を完全に補償するものとし、TI は一切の責任を拒否します。

TI の製品は、[TI の販売条件](#)、または [ti.com](#) やかかる TI 製品の関連資料などのいずれかを通じて提供する適用可能な条項の下で提供されています。TI がこれらのリソースを提供することは、適用される TI の保証または他の保証の放棄の拡大や変更を意味するものではありません。

お客様がいかなる追加条項または代替条項を提案した場合でも、TI はそれらに異議を唱え、拒否します。

郵送先住所 : Texas Instruments, Post Office Box 655303, Dallas, Texas 75265
Copyright © 2024, Texas Instruments Incorporated