

# CDx4HC393、CDx4HCT393 ハイスピード CMOS ロジック、デュアル、4 段バイナリ・カウンタ

## 1 特長

- 完全静的動作
- バッファ付き入力
- コモン・リセット
- ネガティブ・エッジ・クロッキング
- ファンアウト (全温度範囲にわたって):
  - 標準出力は 10 個の LSTTL 負荷を駆動可能
  - バス・ドライバ出力は 15 個の LSTTL 負荷を駆動可能
- 広い動作温度範囲:  $-55^{\circ}\text{C} \sim 125^{\circ}\text{C}$
- 平衡な伝搬遅延と遷移時間
- LSTTL ロジック IC に比べて消費電力を大幅削減
- HC タイプ
  - 2V~6V で動作
  - 優れたノイズ耐性:  $N_{IL} = V_{CC}$  の 30%、 $N_{IH} = V_{CC}$  の 30% ( $V_{CC} = 5\text{V}$  の場合)
- HCT タイプ
  - 4.5V~5.5V で動作
  - LSTTL 入力ロジックと直接互換、 $V_{IL} = 0.8\text{V}$  (最大値)、 $V_{IH} = 2\text{V}$  (最小値)
  - CMOS 入力互換、 $V_{OL}$ 、 $V_{OH}$  で  $I_L \leq 1\mu\text{A}$

## 2 概要

HC393 と HCT393 は、4 段リップルキャリー・バイナリ・カウンタです。すべてのカウンタ段は、1 次動作可能なフリップ・フロップです。段の状態は、各クロック・パルスの負の遷移時に 1 カウント進み、MR ラインが High レベルになると、すべてのカウンタがゼロ状態にリセットされます。すべての入出力はバッファ付きです。

### デバイス情報

部品番号	パッケージ <sup>(1)</sup>	本体サイズ (公称)
CD74HC393M	SOIC (14)	8.65mm × 3.90mm
CD74HC393E	PDIP (14)	19.31mm × 6.35mm
CD74HCT393M	SOIC (14)	8.65mm × 3.90mm
CD74HCT393E	PDIP (14)	19.31mm × 6.35mm
CD54HC393F3A	CDIP (14)	19.55mm × 6.71mm
CD54HCT393F	CDIP (14)	19.55mm × 6.71mm

(1) 利用可能なすべてのパッケージについては、このデータシートの末尾にある注文情報を参照してください。

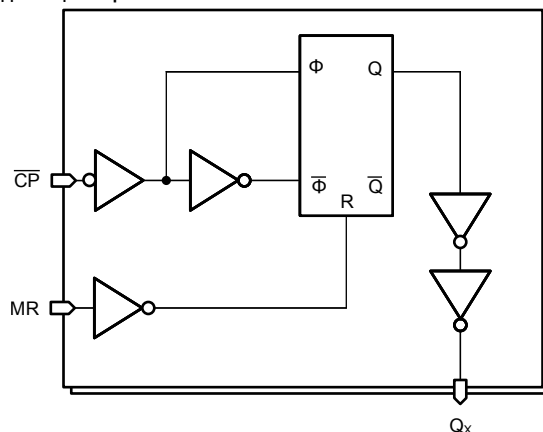

機能ブロック図



## Table of Contents

<b>1 特長</b> .....	1	7.2 Functional Block Diagram.....	9
<b>2 概要</b> .....	1	7.3 Device Functional Modes.....	9
<b>3 Revision History</b> .....	2	<b>8 Power Supply Recommendations</b> .....	11
<b>4 Pin Configuration and Functions</b> .....	3	<b>9 Layout</b> .....	11
<b>5 Specifications</b> .....	4	9.1 Layout Guidelines.....	11
5.1 Absolute Maximum Ratings <sup>(1)</sup> .....	4	<b>10 Device and Documentation Support</b> .....	12
5.2 Recommended Operating Conditions.....	4	10.1 Receiving Notification of Documentation Updates..	12
5.3 Thermal Information.....	4	10.2 サポート・リソース.....	12
5.4 Electrical Characteristics.....	5	10.3 Trademarks.....	12
5.5 Prerequisite for Switching Characteristics.....	6	10.4 Electrostatic Discharge Caution.....	12
5.6 Switching Characteristics.....	6	10.5 Glossary.....	12
<b>6 Parameter Measurement Information</b> .....	8	<b>11 Mechanical, Packaging, and Orderable Information</b> .....	12
<b>7 Detailed Description</b> .....	9		
7.1 Overview.....	9		

### 3 Revision History

資料番号末尾の英字は改訂を表しています。その改訂履歴は英語版に準じています。

<b>Changes from Revision E (August 2003) to Revision F (March 2022)</b>	<b>Page</b>
• 最新のデータシート規格を反映するように、文書全体の採番、書式設定、表、図、相互参照を更新.....	1

## 4 Pin Configuration and Functions

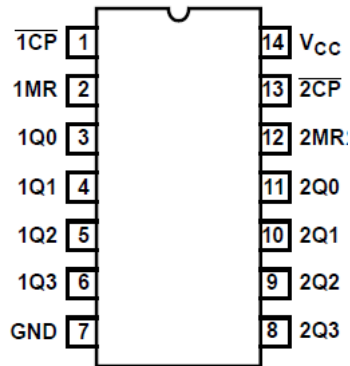

J, N, or D package  
14-PIN CDIP, PDIP, or SOIC  
Top View

## 5 Specifications

### 5.1 Absolute Maximum Ratings<sup>(1)</sup>

		MIN	MAX	UNIT
V <sub>CC</sub>	Supply voltage	-0.5	7	V
I <sub>IK</sub>	Input diode current	For V <sub>I</sub> < -0.5 V or V <sub>I</sub> > V <sub>CC</sub> + 0.5 V		±20 mA
I <sub>OK</sub>	Output diode current	For V <sub>O</sub> < -0.5 V or V <sub>O</sub> > V <sub>CC</sub> + 0.5 V		±20 mA
I <sub>O</sub>	Output source or sink current per output pin	For V <sub>O</sub> > -0.5 V or V <sub>O</sub> < V <sub>CC</sub> + 0.5 V		±25 mA
	Continuous current through V <sub>CC</sub> or GND		±50	mA
T <sub>J</sub>	Junction temperature		150	°C
T <sub>stg</sub>	Storage temperature range	-65	150	°C
	Lead temperature (Soldering 10s) (SOIC - lead tips only)		300	°C

- (1) Stresses above those listed in "Absolute Maximum Ratings" may cause permanent damage to the device. This is a stress only rating and operation of the device at these or any other conditions above those indicated in the operational sections of this specification is not implied.

### 5.2 Recommended Operating Conditions

		MIN	MAX	UNIT	
V <sub>CC</sub>	Supply voltage range	HC types	2	6	V
		HCT types	4.5	5.5	
V <sub>I</sub> , V <sub>O</sub>	DC input or output voltage	0	V <sub>CC</sub>	V	
	Input rise and fall time	2 V	1000	ns	
		4.5 V	500		
		6 V	400		
T <sub>A</sub>	Temperature range	-55	125	°C	

### 5.3 Thermal Information

THERMAL METRIC		D (SOIC)	N (PDIP)	UNIT
		14 PINS	14 PINS	
R <sub>θJA</sub>	Junction-to-ambient thermal resistance <sup>(1)</sup>	86	80	°C/W

- (1) For more information about traditional and new thermal metrics, see the [Semiconductor and IC package thermal metrics](#) application report.

## 5.4 Electrical Characteristics

PARAMETER		TEST CONDITIONS <sup>(2)</sup>	V <sub>CC</sub> (V)	25°C			-40°C to 85°C		-55°C to 125°C		UNIT
				MIN	TYP	MAX	MIN	MAX	MIN	MAX	
<b>HC TYPES</b>											
V <sub>IH</sub>	High level input voltage		2	1.5		1.5		1.5		V	
			4.5	3.15		3.15		3.15			
			6	4.2		4.2		4.2			
V <sub>IL</sub>	Low level input voltage		2		0.5		0.5		0.5	V	
			4.5		1.35		1.35		1.35		
			6		1.8		1.8		1.8		
V <sub>OH</sub>	High level output voltage CMOS loads	I <sub>OH</sub> = -20 μA	2	1.9		1.9		1.9		V	
		I <sub>OH</sub> = -20 μA	4.5	4.4		4.4		4.4			
		I <sub>OH</sub> = -20 μA	6	5.9		5.9		5.9			
	High level output voltage TTL loads	I <sub>OH</sub> = 4 mA	4.5	3.98		3.84		3.7		V	
		I <sub>OH</sub> = 5.2 mA	6	5.48		5.34		5.2			
V <sub>OL</sub>	Low level output voltage CMOS loads	I <sub>OL</sub> = 20 μA	2		0.1		0.1		0.1	V	
		I <sub>OL</sub> = 20 μA	4.5		0.1		0.1		0.1		
		I <sub>OL</sub> = 20 μA	6		0.1		0.1		0.1		
	Low level output voltage TTL loads	I <sub>OL</sub> = 4 mA	4.5		0.26		0.33		0.4	V	
		I <sub>OL</sub> = 5.2 mA	6		0.26		0.33		0.4		
I <sub>I</sub>	Input leakage current	V <sub>CC</sub> or GND	6		±0.1		±1		±1	μA	
I <sub>CC</sub>	Supply current	V <sub>CC</sub> or GND	6		8		80		160	μA	
<b>HCT TYPES</b>											
V <sub>IH</sub>	High level input voltage		4.5 to 5.5	2			2		2	V	
V <sub>IL</sub>	Low level input voltage		4.5 to 5.5		0.8		0.8		0.8	V	
V <sub>OH</sub>	High level output voltage CMOS loads	I <sub>OH</sub> = -20 μA	4.5	4.4		4.4		4.4		V	
	High level output voltage TTL loads	I <sub>OH</sub> = -4 mA	4.5	3.98		3.84		3.7		V	
V <sub>OL</sub>	Low level output voltage CMOS loads	I <sub>OL</sub> = 20 μA	4.5		0.1		0.1		0.1	V	
	Low level output voltage TTL loads	I <sub>OL</sub> = 4 mA	4.5		0.26		0.33		0.4	V	
I <sub>I</sub>	Input leakage current	V <sub>CC</sub> and GND	5.5		±0.1		±1		±1	μA	
I <sub>CC</sub>	Supply current	V <sub>CC</sub> or GND	5.5		8		80		160	μA	
ΔI <sub>CC</sub> <sup>(1)</sup>	Additional supply current per input pin	nCP input held at V <sub>CC</sub> - 2.1	4.5 to 5.5	100	144		180		196	μA	
		nMR input held at V <sub>CC</sub> - 2.1	4.5 to 5.5	100	360		450		490	μA	

(1) For dual-supply systems theoretical worst case (V<sub>I</sub> = 2.4 V, V<sub>CC</sub> = 5.5 V) specification is 1.8 mA.

(2) V<sub>I</sub> = V<sub>IH</sub> or V<sub>IL</sub>, unless otherwise noted.

## 5.5 Prerequisite for Switching Characteristics

PARAMETER		V <sub>CC</sub> (V)	25°C			-40°C to 85°C		-55°C to 125°C		UNIT
			MIN	TYP	MAX	MIN	MAX	MIN	MAX	
<b>HC TYPES</b>										
f <sub>MAX</sub>	Maximum clock frequency	2	6			5		4		MHz
		4.5	30			24		20		
		6	35			28		24		
t <sub>W</sub>	Clock pulse width	2	80			100		120		ns
		4.5	16			20		24		
		6	14			17		20		
t <sub>REC</sub>	Reset recovery time	2	5			5		5		ns
		4.5	5			5		5		
		6	5			5		5		
t <sub>W</sub>	Reset pulse width	2	80			100		120		ns
		4.5	16			20		24		
		6	14			17		20		
<b>HCT TYPES</b>										
f <sub>MAX</sub>	Maximum clock frequency	4.5	27			22		18		MHz
t <sub>W</sub>	Clock pulse width	4.5	19			24		29		ns
t <sub>REC</sub>	Reset recovery time	4.5	5			5		5		ns
t <sub>W</sub>	Reset pulse width	4.5	16			20		24		ns

## 5.6 Switching Characteristics

Input t<sub>r</sub>, t<sub>f</sub> = 6 ns. See (Parameter Measurement Information)

PARAMETER		TEST CONDITIONS	V <sub>CC</sub> (V)	25°C			-40°C to 85°C		-55°C to 125°C		UNIT
				MIN	TYP	MAX	MIN	MAX	MIN	MAX	
<b>HC TYPES</b>											
t <sub>PLH</sub> , t <sub>PHL</sub>	Propagation delay time nCP̄ to nQ <sub>0</sub>	C <sub>L</sub> = 50 pF	2	150			190		225		ns
			4.5	30			38		59		
		C <sub>L</sub> = 15 pF	5	12							ns
			6	26			33		50		ns
t <sub>PLH</sub> , t <sub>PHL</sub>	nCP̄ to nQ <sub>1</sub>	C <sub>L</sub> = 50 pF	2	190			245		295		ns
			4.5	38			49		59		
			6	33			42		50		
t <sub>PLH</sub> , t <sub>PHL</sub>	nCP̄ to nQ <sub>2</sub>	C <sub>L</sub> = 50 pF	2	240			300		360		ns
			4.5	48			60		72		
			6	41			51		61		
t <sub>PLH</sub> , t <sub>PHL</sub>	nCP̄ to nQ <sub>3</sub>	C <sub>L</sub> = 50 pF	2	285			355		430		ns
			4.5	57			71		86		
			6	48			60		73		
t <sub>PLH</sub> , t <sub>PHL</sub>	MR to Q <sub>n</sub>	C <sub>L</sub> = 50 pF	2	135			170		205		ns
			4.5	27			34		41		
		C <sub>L</sub> = 15 pF	5	11							ns
			6	23			29		35		

## 5.6 Switching Characteristics (continued)

Input  $t_r$ ,  $t_f = 6$  ns. See (Parameter Measurement Information)

PARAMETER		TEST CONDITIONS	$V_{CC}$ (V)	25°C			-40°C to 85°C		-55°C to 125°C		UNIT
				MIN	TYP	MAX	MIN	MAX	MIN	MAX	
$t_{TLH}$ , $t_{THL}$	Output transition time	$C_L = 50$ pF	2		75		95		110	ns	
			4.5		15		19		22		
			6		13		16		19		
$C_{IN}$	Input capacitance	$C_L = 50$ pF			10		10		10	pF	
$C_{PD}$	Power dissipation capacitance <sup>(1) (2)</sup>	$C_L = 15$ pF	5		20					pF	
<b>HCT TYPES</b>											
$t_{PLH}$ , $t_{PHL}$	Propagation delay time $n\overline{CP}$ to $nQ_0$	$C_L = 50$ pF	4.5		32		40		48	ns	
		$C_L = 15$ pF	5		13					ns	
$t_{PLH}$ , $t_{PHL}$	$n\overline{CP}$ to $nQ_1$	$C_L = 50$ pF	4.5		44		55		66	ns	
$t_{PLH}$ , $t_{PHL}$	$n\overline{CP}$ to $nQ_2$	$C_L = 50$ pF	4.5		50		63		75	ns	
$t_{PLH}$ , $t_{PHL}$	$n\overline{CP}$ to $nQ_3$	$C_L = 50$ pF	4.5		62		78		93	ns	
$t_{PLH}$ , $t_{PHL}$	MR to $Q_n$	$C_L = 50$ pF	4.5		32		40		48	ns	
		$C_L = 15$ pF	5		13					ns	
$t_{TLH}$ , $t_{THL}$	Output transition	$C_L = 50$ pF	4.5		15		19		22	ns	
$C_{IN}$	Input capacitance	$C_L = 15$ pF			10		10		10	pF	
$C_{PD}$	Power dissipation capacitance <sup>(1) (2)</sup>	$C_L = 15$ pF	5		21					pF	

(1)  $C_{PD}$  is used to determine the dynamic power consumption, per stage.

(2)  $P_D = V_{CC}^2 f_i (C_{PD} + C_L)$  where  $f_i$  = input frequency,  $C_L$  = output load capacitance,  $V_{CC}$  = supply voltage.

## 6 Parameter Measurement Information

Phase relationships between waveforms were chosen arbitrarily. All input pulses are supplied by generators having the following characteristics:  $PRR \leq 1 \text{ MHz}$ ,  $Z_O = 50 \Omega$ ,  $t_t < 6 \text{ ns}$ .

For clock inputs,  $f_{\text{max}}$  is measured when the input duty cycle is 50%.

The outputs are measured one at a time with one input transition per measurement.



(1)  $C_L$  includes probe and test-fixture capacitance.

**6-1. Load Circuit for Push-Pull Outputs**

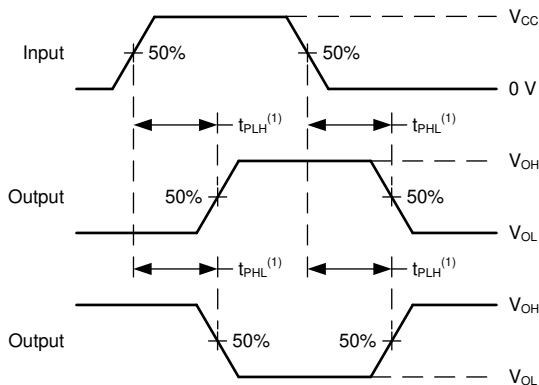

(1) The greater between  $t_{\text{PLH}}$  and  $t_{\text{PHL}}$  is the same as  $t_{\text{pd}}$ .

**6-2. Voltage Waveforms, Propagation Delays for Standard CMOS Inputs**

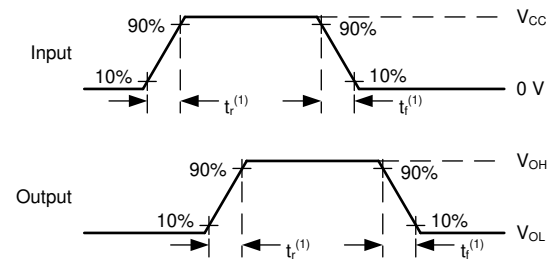

(1) The greater between  $t_r$  and  $t_f$  is the same as  $t_t$ .

**6-3. Voltage Waveforms, Input and Output Transition Times for Standard CMOS Inputs**

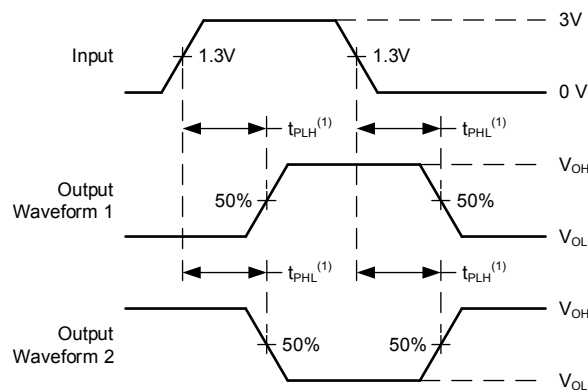

(1) The greater between  $t_{\text{PLH}}$  and  $t_{\text{PHL}}$  is the same as  $t_{\text{pd}}$ .

**6-4. Voltage Waveforms, Propagation Delays for TTL-Compatible Inputs**



## 7 Detailed Description

### 7.1 Overview

The 'HC393 and 'HCT393 are 4-stage ripple-carry binary counters. All counter stages are controller flip-flops. The state of the stage advances one count on the negative transition of each clock pulse; a high voltage level on the MR line resets all counters to their zero state. All inputs and outputs are buffered.

### 7.2 Functional Block Diagram



图 7-1. Functional Diagram

### 7.3 Device Functional Modes

表 7-1. Truth Table<sup>(1)</sup>

CP COUNT	OUTPUTS			
	Q <sub>0</sub>	Q <sub>1</sub>	Q <sub>2</sub>	Q <sub>3</sub>
0	L	L	L	L
1	H	L	L	L
2	L	H	L	L
3	H	H	L	L
4	L	L	H	L
5	H	L	H	L
6	L	H	H	L
7	H	H	H	L
8	L	L	L	H
9	H	L	L	H
10	L	H	L	H
11	H	H	L	H
12	L	L	H	H
13	H	L	H	H
14	L	H	H	H
15	H	H	H	H

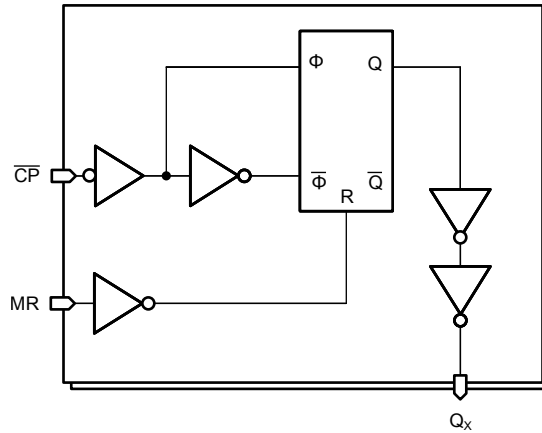
(1) H = high voltage level, L = low voltage level, X = don't care, ↑ = transition from low to high level, ↓ = transition from high to low.

表 7-2. Truth Table<sup>(1)</sup>

CP COUNT	MR	OUTPUT
↑	L	No change
↓	L	Count
X	H	L L L L

(1) H = high voltage level, L = low voltage level, X = don't care, ↑ = transition from low to high level, ↓ = transition from high to low.

## 8 Power Supply Recommendations

The power supply can be any voltage between the minimum and maximum supply voltage rating located in the *Recommended Operating Conditions*. Each  $V_{CC}$  terminal should have a good bypass capacitor to prevent power disturbance. A 0.1- $\mu\text{F}$  capacitor is recommended for this device. It is acceptable to parallel multiple bypass caps to reject different frequencies of noise. The 0.1- $\mu\text{F}$  and 1- $\mu\text{F}$  capacitors are commonly used in parallel. The bypass capacitor should be installed as close to the power terminal as possible for best results.

## 9 Layout

### 9.1 Layout Guidelines

When using multiple-input and multiple-channel logic devices inputs must not ever be left floating. In many cases, functions or parts of functions of digital logic devices are unused; for example, when only two inputs of a triple-input AND gate are used or only 3 of the 4 buffer gates are used. Such unused input pins must not be left unconnected because the undefined voltages at the outside connections result in undefined operational states. All unused inputs of digital logic devices must be connected to a logic high or logic low voltage, as defined by the input voltage specifications, to prevent them from floating. The logic level that must be applied to any particular unused input depends on the function of the device. Generally, the inputs are tied to GND or  $V_{CC}$ , whichever makes more sense for the logic function or is more convenient.

## 10 Device and Documentation Support

TI offers an extensive line of development tools. Tools and software to evaluate the performance of the device, generate code, and develop solutions are listed below.

### 10.1 Receiving Notification of Documentation Updates

To receive notification of documentation updates, navigate to the device product folder on [ti.com](http://ti.com). Click on *Subscribe to updates* to register and receive a weekly digest of any product information that has changed. For change details, review the revision history included in any revised document.

### 10.2 サポート・リソース

TI E2E™ サポート・フォーラムは、エンジニアが検証済みの回答と設計に関するヒントをエキスパートから迅速かつ直接得ることができる場所です。既存の回答を検索したり、独自の質問をしたりすることで、設計に必要な支援を迅速に得ることができます。

リンクされているコンテンツは、該当する貢献者により、現状のまま提供されるものです。これらは TI の仕様を構成するものではなく、必ずしも TI の見解を反映したものではありません。TI の [使用条件](#) を参照してください。

### 10.3 Trademarks

TI E2E™ is a trademark of Texas Instruments.

すべての商標は、それぞれの所有者に帰属します。

### 10.4 Electrostatic Discharge Caution



This integrated circuit can be damaged by ESD. Texas Instruments recommends that all integrated circuits be handled with appropriate precautions. Failure to observe proper handling and installation procedures can cause damage.

ESD damage can range from subtle performance degradation to complete device failure. Precision integrated circuits may be more susceptible to damage because very small parametric changes could cause the device not to meet its published specifications.

### 10.5 Glossary

[TI Glossary](#) This glossary lists and explains terms, acronyms, and definitions.

## 11 Mechanical, Packaging, and Orderable Information

The following pages include mechanical, packaging, and orderable information. This information is the most current data available for the designated devices. This data is subject to change without notice and revision of this document. For browser-based versions of this data sheet, refer to the left-hand navigation.

**PACKAGING INFORMATION**

Orderable Device	Status (1)	Package Type	Package Drawing	Pins	Package Qty	Eco Plan (2)	Lead finish/ Ball material (6)	MSL Peak Temp (3)	Op Temp (°C)	Device Marking (4/5)	Samples
5962-8989001CA	ACTIVE	CDIP	J	14	25	Non-RoHS & Green	SNPB	N / A for Pkg Type	-55 to 125	5962-8989001CA CD54HCT393F3A	<a href="#">Samples</a>
CD54HC393F3A	ACTIVE	CDIP	J	14	25	Non-RoHS & Green	SNPB	N / A for Pkg Type	-55 to 125	8410001CA CD54HC393F3A	<a href="#">Samples</a>
CD54HCT393F	ACTIVE	CDIP	J	14	25	Non-RoHS & Green	SNPB	N / A for Pkg Type	-55 to 125	CD54HCT393F	<a href="#">Samples</a>
CD54HCT393F3A	ACTIVE	CDIP	J	14	25	Non-RoHS & Green	SNPB	N / A for Pkg Type	-55 to 125	5962-8989001CA CD54HCT393F3A	<a href="#">Samples</a>
CD74HC393E	ACTIVE	PDIP	N	14	25	RoHS & Green	NIPDAU	N / A for Pkg Type	-55 to 125	CD74HC393E	<a href="#">Samples</a>
CD74HC393M	OBSOLETE	SOIC	D	14		TBD	Call TI	Call TI	-55 to 125	HC393M	
CD74HC393M96	ACTIVE	SOIC	D	14	2500	RoHS & Green	NIPDAU   SN	Level-1-260C-UNLIM	-55 to 125	HC393M	<a href="#">Samples</a>
CD74HCT393E	ACTIVE	PDIP	N	14	25	RoHS & Green	NIPDAU	N / A for Pkg Type	-55 to 125	CD74HCT393E	<a href="#">Samples</a>
CD74HCT393M96	ACTIVE	SOIC	D	14	2500	RoHS & Green	NIPDAU   SN	Level-1-260C-UNLIM	-55 to 125	HCT393M	<a href="#">Samples</a>
CD74HCT393MT	OBSOLETE	SOIC	D	14		TBD	Call TI	Call TI	-55 to 125	HCT393M	

(1) The marketing status values are defined as follows:

**ACTIVE:** Product device recommended for new designs.

**LIFEBUY:** TI has announced that the device will be discontinued, and a lifetime-buy period is in effect.

**NRND:** Not recommended for new designs. Device is in production to support existing customers, but TI does not recommend using this part in a new design.

**PREVIEW:** Device has been announced but is not in production. Samples may or may not be available.

**OBSOLETE:** TI has discontinued the production of the device.

(2) **RoHS:** TI defines "RoHS" to mean semiconductor products that are compliant with the current EU RoHS requirements for all 10 RoHS substances, including the requirement that RoHS substance do not exceed 0.1% by weight in homogeneous materials. Where designed to be soldered at high temperatures, "RoHS" products are suitable for use in specified lead-free processes. TI may reference these types of products as "Pb-Free".

**RoHS Exempt:** TI defines "RoHS Exempt" to mean products that contain lead but are compliant with EU RoHS pursuant to a specific EU RoHS exemption.

**Green:** TI defines "Green" to mean the content of Chlorine (Cl) and Bromine (Br) based flame retardants meet JS709B low halogen requirements of <=1000ppm threshold. Antimony trioxide based flame retardants must also meet the <=1000ppm threshold requirement.

(3) MSL, Peak Temp. - The Moisture Sensitivity Level rating according to the JEDEC industry standard classifications, and peak solder temperature.

(4) There may be additional marking, which relates to the logo, the lot trace code information, or the environmental category on the device.

<sup>(5)</sup> Multiple Device Markings will be inside parentheses. Only one Device Marking contained in parentheses and separated by a "~" will appear on a device. If a line is indented then it is a continuation of the previous line and the two combined represent the entire Device Marking for that device.

<sup>(6)</sup> Lead finish/Ball material - Orderable Devices may have multiple material finish options. Finish options are separated by a vertical ruled line. Lead finish/Ball material values may wrap to two lines if the finish value exceeds the maximum column width.

**Important Information and Disclaimer:**The information provided on this page represents TI's knowledge and belief as of the date that it is provided. TI bases its knowledge and belief on information provided by third parties, and makes no representation or warranty as to the accuracy of such information. Efforts are underway to better integrate information from third parties. TI has taken and continues to take reasonable steps to provide representative and accurate information but may not have conducted destructive testing or chemical analysis on incoming materials and chemicals. TI and TI suppliers consider certain information to be proprietary, and thus CAS numbers and other limited information may not be available for release.

In no event shall TI's liability arising out of such information exceed the total purchase price of the TI part(s) at issue in this document sold by TI to Customer on an annual basis.

**OTHER QUALIFIED VERSIONS OF CD54HC393, CD54HCT393, CD74HC393, CD74HCT393 :**

- Catalog : [CD74HC393](#), [CD74HCT393](#)
- Military : [CD54HC393](#), [CD54HCT393](#)

NOTE: Qualified Version Definitions:

- Catalog - TI's standard catalog product
- Military - QML certified for Military and Defense Applications

**TAPE AND REEL INFORMATION**

**QUADRANT ASSIGNMENTS FOR PIN 1 ORIENTATION IN TAPE**

\*All dimensions are nominal

Device	Package Type	Package Drawing	Pins	SPQ	Reel Diameter (mm)	Reel Width W1 (mm)	A0 (mm)	B0 (mm)	K0 (mm)	P1 (mm)	W (mm)	Pin1 Quadrant
CD74HC393M96	SOIC	D	14	2500	330.0	16.4	6.5	9.0	2.1	8.0	16.0	Q1
CD74HC393M96	SOIC	D	14	2500	330.0	16.4	6.6	9.3	2.1	8.0	16.0	Q1
CD74HC393M96	SOIC	D	14	2500	330.0	16.4	6.5	9.0	2.1	8.0	16.0	Q1
CD74HCT393M96	SOIC	D	14	2500	330.0	16.4	6.5	9.0	2.1	8.0	16.0	Q1
CD74HCT393M96	SOIC	D	14	2500	330.0	16.4	6.5	9.0	2.1	8.0	16.0	Q1
CD74HCT393M96	SOIC	D	14	2500	330.0	16.4	6.6	9.3	2.1	8.0	16.0	Q1

**TAPE AND REEL BOX DIMENSIONS**

\*All dimensions are nominal

Device	Package Type	Package Drawing	Pins	SPQ	Length (mm)	Width (mm)	Height (mm)
CD74HC393M96	SOIC	D	14	2500	356.0	356.0	35.0
CD74HC393M96	SOIC	D	14	2500	366.0	364.0	50.0
CD74HC393M96	SOIC	D	14	2500	356.0	356.0	35.0
CD74HCT393M96	SOIC	D	14	2500	356.0	356.0	35.0
CD74HCT393M96	SOIC	D	14	2500	356.0	356.0	35.0
CD74HCT393M96	SOIC	D	14	2500	366.0	364.0	50.0



**TUBE**

\*All dimensions are nominal

Device	Package Name	Package Type	Pins	SPQ	L (mm)	W (mm)	T (μm)	B (mm)
CD74HC393E	N	PDIP	14	25	506	13.97	11230	4.32
CD74HC393E	N	PDIP	14	25	506	13.97	11230	4.32
CD74HCT393E	N	PDIP	14	25	506	13.97	11230	4.32
CD74HCT393E	N	PDIP	14	25	506	13.97	11230	4.32

J 14

**GENERIC PACKAGE VIEW**  
**CDIP - 5.08 mm max height**  
CERAMIC DUAL IN LINE PACKAGE



Images above are just a representation of the package family, actual package may vary.  
Refer to the product data sheet for package details.

4040083-5/G

J0014A



# PACKAGE OUTLINE

CDIP - 5.08 mm max height

CERAMIC DUAL IN LINE PACKAGE



4214771/A 05/2017

NOTES:

1. All controlling linear dimensions are in inches. Dimensions in brackets are in millimeters. Any dimension in brackets or parenthesis are for reference only. Dimensioning and tolerancing per ASME Y14.5M.
2. This drawing is subject to change without notice.
3. This package is hermetically sealed with a ceramic lid using glass frit.
4. Index point is provided on cap for terminal identification only and on press ceramic glass frit seal only.
5. Falls within MIL-STD-1835 and GDIP1-T14.

# EXAMPLE BOARD LAYOUT

J0014A

CDIP - 5.08 mm max height

CERAMIC DUAL IN LINE PACKAGE



LAND PATTERN EXAMPLE  
NON-SOLDER MASK DEFINED  
SCALE: 5X



4214771/A 05/2017

D (R-PDSO-G14)

PLASTIC SMALL OUTLINE



- NOTES:
- A. All linear dimensions are in inches (millimeters).
  - B. This drawing is subject to change without notice.
  -  Body length does not include mold flash, protrusions, or gate burrs. Mold flash, protrusions, or gate burrs shall not exceed 0.006 (0,15) each side.
  -  Body width does not include interlead flash. Interlead flash shall not exceed 0.017 (0,43) each side.
  - E. Reference JEDEC MS-012 variation AB.

D (R-PDSO-G14)

PLASTIC SMALL OUTLINE



4211283-3/E 08/12

- NOTES:
- All linear dimensions are in millimeters.
  - This drawing is subject to change without notice.
  - Publication IPC-7351 is recommended for alternate designs.
  - Laser cutting apertures with trapezoidal walls and also rounding corners will offer better paste release. Customers should contact their board assembly site for stencil design recommendations. Refer to IPC-7525 for other stencil recommendations.
  - Customers should contact their board fabrication site for solder mask tolerances between and around signal pads.

N (R-PDIP-T\*\*)

PLASTIC DUAL-IN-LINE PACKAGE

16 PINS SHOWN



4040049/E 12/2002

- NOTES:
- A. All linear dimensions are in inches (millimeters).
  - B. This drawing is subject to change without notice.
  - $\triangle C$  Falls within JEDEC MS-001, except 18 and 20 pin minimum body length (Dim A).
  - $\triangle D$  The 20 pin end lead shoulder width is a vendor option, either half or full width.

## 重要なお知らせと免責事項

TI は、技術データと信頼性データ（データシートを含みます）、設計リソース（リファレンス・デザインを含みます）、アプリケーションや設計に関する各種アドバイス、Web ツール、安全性情報、その他のリソースを、欠陥が存在する可能性のある「現状のまま」提供しており、商品性および特定目的に対する適合性の黙示保証、第三者の知的財産権の非侵害保証を含むいかなる保証も、明示的または黙示的にかかわらず拒否します。

これらのリソースは、TI 製品を使用する設計の経験を積んだ開発者への提供を意図したものです。(1) お客様のアプリケーションに適した TI 製品の選定、(2) お客様のアプリケーションの設計、検証、試験、(3) お客様のアプリケーションに該当する各種規格や、その他のあらゆる安全性、セキュリティ、規制、または他の要件への確実な適合に関する責任を、お客様のみが単独で負うものとし、

上記の各種リソースは、予告なく変更される可能性があります。これらのリソースは、リソースで説明されている TI 製品を使用するアプリケーションの開発の目的でのみ、TI はその使用をお客様に許諾します。これらのリソースに関して、他の目的で複製することや掲載することは禁止されています。TI や第三者の知的財産権のライセンスが付与されている訳ではありません。お客様は、これらのリソースを自身で使用した結果発生するあらゆる申し立て、損害、費用、損失、責任について、TI およびその代理人を完全に補償するものとし、TI は一切の責任を拒否します。

TI の製品は、[TI の販売条件](#)、または [ti.com](#) やかかる TI 製品の関連資料などのいずれかを通じて提供する適用可能な条項の下で提供されています。TI がこれらのリソースを提供することは、適用される TI の保証または他の保証の放棄の拡大や変更を意味するものではありません。

お客様がいかなる追加条項または代替条項を提案した場合でも、TI はそれらに異議を唱え、拒否します。

郵送先住所：Texas Instruments, Post Office Box 655303, Dallas, Texas 75265  
Copyright © 2024, Texas Instruments Incorporated