

DS90LVRA2-Q1 車載対応、LVDS デュアル差動ラインレシーバ

1 特長

- 車載アプリケーション向けに AEC-Q100 および AEC-Q006 認定済み
 - 温度グレード 2: -40°C ~ +105°C
- 600Mbps (300MHz) のスイッチング レート
- 50ps の差動スキュー (標準値)
- 0.1ns のチャンネル間スキュー (標準値)
- 1.8V ~ 3.3V の電源に対応
- フロースルーのピン配置
- 電源オフ時に高インピーダンスになる LVDS 入力
- 出力スルーレート制御
- LVDS 入力は LVDS/CML/LVPECL 信号に対応
- ANSI/TIA/EIA-644 規格に準拠
- DS90LV028A-Q1 とピン互換

2 アプリケーション

- 車載用インフォテインメントおよびクラスタ
- 車載ヘッド ユニット

3 概要

DS90LVRA2-Q1 は、デュアル CMOS 差動ラインレシーバであり、広い入力同相範囲、高いデータレート、スルーレート制御付き CMOS 出力を必要とするアプリケーション向けに設計されています。このデバイスは、低電圧差動信号 (LVDS) テクノロジーを活用して、600Mbps (300MHz) のデータ速度をサポートするよう設計されています。

DS90LVRA2-Q1 は、低電圧 (標準値 350mV) の差動入力信号を受信し、電源電圧に応じて 1.8V から 3.3V CMOS 出力レベルへ変換します。DS90LVRA2-Q1 は、フロースルー設計を採用しており、PCB レイアウトが容易です。

DS90LVRA2-Q1 およびこれと対になる LVDS ラインドライバ DS90LV027AQ は、消費電力の大きい PECL/ECL デバイスの新しい代替品として、高速のポイントツーポイント インターフェイス アプリケーションに使用できます。

パッケージ情報

部品番号	パッケージ ⁽¹⁾	パッケージサイズ ⁽²⁾
DS90LVRA2-Q1	DEM (WSON, 8)	2mm × 2mm

- 詳細については、[セクション 11](#) を参照してください。
- パッケージサイズ (長さ×幅) は公称値で、該当する場合はピンも含まれます。

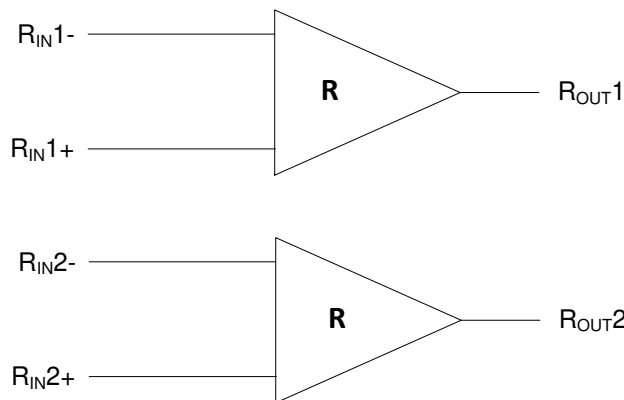

機能図



Table of Contents

1 特長	1	7.4 Device Functional Modes.....	9
2 アプリケーション	1	8 Application and Implementation	10
3 概要	1	8.1 Application Information.....	10
4 Pin Configuration and Functions	3	8.2 Typical Application.....	10
5 Specifications	4	8.3 Power Supply Recommendations.....	11
5.1 Absolute Maximum Ratings.....	4	8.4 Layout.....	11
5.2 ESD Ratings.....	4	9 Device and Documentation Support	13
5.3 Recommended Operating Conditions.....	4	9.1 Documentation Support.....	13
5.4 Thermal Information.....	4	9.2 ドキュメントの更新通知を受け取る方法.....	13
5.5 Electrical Characteristics.....	5	9.3 サポート・リソース.....	13
5.6 Switching Characteristics.....	6	9.4 Trademarks.....	13
5.7 Typical Characteristics.....	7	9.5 静電気放電に関する注意事項.....	13
6 Parameter Measurement Information	8	9.6 用語集.....	13
7 Detailed Description	9	10 Revision History	13
7.1 Overview.....	9	11 Mechanical, Packaging, and Orderable Information	13
7.2 Functional Block Diagram.....	9		
7.3 Feature Description.....	9		

4 Pin Configuration and Functions



図 4-1. DEM Package, WSON 8 Pin (Top View)

表 4-1. Pin Functions

PIN		TYPE ⁽¹⁾	DESCRIPTION
NAME	NO.		
GND	5	G	Ground pin
R _{IN1-}	1	I	Inverting receiver input pin
R _{IN2-}	4	I	
R _{IN1+}	2	I	Non-inverting receiver input pin
R _{IN2+}	3	I	
R _{OUT2}	6	O	Receiver output pin
R _{OUT1}	7	O	
V _{CC}	8	P	Power supply pin

(1) I = input, O = output, G = ground

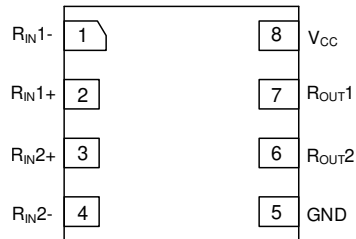
5 Specifications

5.1 Absolute Maximum Ratings

over operating free-air temperature range (unless otherwise noted)⁽¹⁾

		MIN	MAX	UNIT
Supply Voltage (V_{CC})		-0.3	4	V
Input Voltage (R_{IN+} , R_{IN-})		-5	6	V
Differential Voltage (R_{IN+} - R_{IN-}) for LVDS		0	3	V
Output Voltage (R_{OUT})		-0.3	3.6	V
Lead Temperature Range Soldering	(4 sec.)		260	°C
Maximum Junction Temperature			135	°C
Storage temperature, T_{stg}		-65	150	°C

- (1) Operation outside the *Absolute Maximum Rating* may cause permanent device damage. *Absolute Maximum Rating* do not imply functional operation of the device at these or any other conditions beyond those listed under *Recommended Operating Condition*. If used outside the *Recommended Operating Condition* but within the *Absolute Maximum Rating*, the device may not be fully functional, and this may affect device reliability, functionality, performance, and shorten the device lifetime.

5.2 ESD Ratings

			VALUE	UNIT
$V_{(ESD)}$	Electrostatic discharge	Human-body model (HBM), per AEC Q100-002 ⁽¹⁾	±2000	V
		Charged-device model (CDM), per AEC Q100-011 ⁽²⁾	±1000	

- (1) AEC Q100-002 HBM ESD Classification Level 2
 (2) AEC Q100-011 CDM ESD Classification Level C4A

5.3 Recommended Operating Conditions

over operating free-air temperature range (unless otherwise noted)

		MIN	NOM	MAX	UNIT
V_{CC}	Supply voltage (3.3V mode)	3.0	3.3	3.6	V
V_{CC}	Supply voltage (2.5V mode)	2.25	2.5	2.75	V
V_{CC}	Supply voltage (1.8V mode)	1.62	1.80	1.98	V
V_R	Receiver input voltage (LVDS)	0		3.0	V
T_A	Operating free-air temperature	-40		105	°C
T_{PCB}	PCB temperature (1mm away from device)			112	°C
T_J	Junction temperature			125	°C

5.4 Thermal Information

THERMAL METRIC ⁽¹⁾		DEM	UNIT
		(WSON)	
		8 PINS	
$R_{\theta JA}$	Junction-to-ambient thermal resistance	143.7	°C/W
$R_{\theta JC(top)}$	Junction-to-case (top) thermal resistance	77.9	°C/W
$R_{\theta JB}$	Junction-to-board thermal resistance	69.8	°C/W
Ψ_{JT}	Junction-to-top characterization parameter	5.0	°C/W
Ψ_{JB}	Junction-to-board characterization parameter	69.6	°C/W

- (1) For more information about traditional and new thermal metrics, see the [Semiconductor and IC Package Thermal Metrics](#) application report.

5.5 Electrical Characteristics

over recommended operating conditions (unless otherwise noted)

PARAMETER		TEST CONDITIONS	MIN	TYP	MAX	UNIT
V_{ITH}	Differential input high threshold	$V_{IB} = -4\text{ V or }5\text{ V}, V_{CC} = 1.62\text{ V to }3.6\text{ V}$	100			mV
V_{ITL}	Differential input low threshold		-100			
V_{HYS}	Differential input voltage hysteresis, $V_{IT1} - V_{IT2}$	$V_{CC} = 1.62\text{ V to }3.6\text{ V}$	20	40	120	mV
V_{CM_RANGE}	Input common mode voltage range	$V_{CC} = 1.62 - 1.98\text{ V}$	-1	1.2	2	V
		$V_{CC} = 2.3 - 2.7\text{ V}$	-2.5	1.2	3	V
		$V_{CC} = 3.0 - 3.6\text{ V}$	-4	1.2	5	V
V_{OH}	High-level output voltage	$I_{OH} = -4\text{ mA}, V_{CC} = 1.8\text{ V} \pm 10\%$	1.3			V
		$I_{OH} = -4\text{ mA}, V_{CC} = 2.5\text{ V} \pm 10\%$	1.8			V
		$I_{OH} = -4\text{ mA}, V_{CC} = 3.3\text{ V} \pm 10\%$	2.6			V
V_{OL}	Low-level output voltage	$I_{OL} = 4\text{ mA}, V_{CC} = 1.8\text{ V} \pm 10\%$	0.2			V
		$I_{OL} = 4\text{ mA}, V_{CC} = 2.5\text{ V} \pm 10\%$	0.3			V
		$I_{OL} = 4\text{ mA}, V_{CC} = 3.3\text{ V} \pm 10\%$	0.4			V
I_{CC_ACTIVE}	Supply current	$V_{CC} = 3.6\text{ V}, \text{ No load, Steady-state, } V_{ID}=200\text{ mV/-}200\text{ mV}$	25			mA
		$V_{CC} = 2.7\text{ V}, \text{ No load, Steady-state, } V_{ID}=200\text{ mV/-}200\text{ mV}$	25			mA
		$V_{CC} = 1.98\text{ V}, \text{ No load, Steady-state, } V_{ID}=200\text{ mV/-}200\text{ mV}$	25			mA
I_I	Input current (A or B inputs)	$V_I = -1.0\text{ V}, \text{ Other input open}$	± 35			μA
		$V_I = 2.4\text{ V}, \text{ Other input open}$	± 20			μA
		$V_I = -4\text{ V}, \text{ Other input open (split between } 85^\circ\text{C) } (\pm 80\ \mu\text{A})$	± 120			μA
		$V_I = 5\text{ V}, \text{ Other input open}$	± 40			μA
$I_{I(OFF)}$	Power-off output current (Y or Z outputs)	$V_Y \text{ or } V_Z = 1.98\text{ V}, V_{CC} = 0\text{ V}$	± 20			μA
$I_{I(OFF)}$	Power-off input current (A or B inputs)	$V_A \text{ or } V_B = -1\text{ V or }2.0\text{ V}, V_{CC} = 0\text{ V}$	± 30			μA
		$V_A \text{ or } V_B = -4\text{ or }5\text{ V}, V_{CC} = 0\text{ V}$	± 70			μA
		$V_A \text{ or } V_B = 0\text{ V or }2.4\text{ V}, V_{CC} = 0\text{ V}$	± 30			μA

5.6 Switching Characteristics

$V_{ID} = 200\text{mV}$, $C_L = 10\text{pF}$ and over operating temperature ranges, unless otherwise specified. ⁽¹⁾ ⁽²⁾

Symbol	Parameter	Conditions	MIN	TYP	MAX	UNIT
t_{PHLD}	Differential Propagation Delay High to Low	$V_{CC} = 1.8\text{V} \pm 10\%$, $\text{trf} = 1\text{ns}$	2.5	4.4	7.7	ns
		$V_{CC} = 2.5\text{V} \pm 10\%$, $\text{trf} = 1\text{ns}$	2.2	3.3	5.1	ns
		$V_{CC} = 3.3\text{V} \pm 10\%$, $\text{trf} = 1\text{ns}$	1.9	2.9	4.1	ns
t_{PLHD}	Differential Propagation Delay Low to High	$V_{CC} = 1.8\text{V} \pm 10\%$, $\text{trf} = 1\text{ns}$	2.7	4.4	7.7	ns
		$V_{CC} = 2.5\text{V} \pm 10\%$, $\text{trf} = 1\text{ns}$	2.4	3.4	5.1	ns
		$V_{CC} = 3.3\text{V} \pm 10\%$, $\text{trf} = 1\text{ns}$	2.2	3.1	4.1	ns
t_{SKD1_S}	Differential Pulse Skew ($t_{PHLD} - t_{PLHD}$) ⁽³⁾	$V_{CC} = 1.8\text{V} \pm 10\%$, $\text{trf} = 1\text{ns}$	-680		680	ps
		$V_{CC} = 2.5\text{V} \pm 10\%$, $\text{trf} = 1\text{ns}$	-500		500	ps
		$V_{CC} = 3.3\text{V} \pm 10\%$, $\text{trf} = 1\text{ns}$	-610		610	ps
t_{SKD1_400M}	Differential Pulse Skew ($t_{PHLD} - t_{PLHD}$) ⁽³⁾	$V_{CC} = 1.8\text{V} \pm 10\%$, $\text{trf} = 0.25\text{ns}$, 400Mbps	-1990		1990	ps
		$V_{CC} = 2.5\text{V} \pm 10\%$, $\text{trf} = 0.25\text{ns}$, 400Mbps	-1400		1400	ps
		$V_{CC} = 3.3\text{V} \pm 10\%$, $\text{trf} = 0.25\text{ns}$, 400Mbps	-1800		1800	ps
t_{SKD2}	Differential Channel-to-Channel Skew ⁽⁴⁾	$V_{CC} = 1.8\text{V} \pm 10\%$, $\text{trf} = 0.25\text{ns}$			0.6	ns
		$V_{CC} = 2.5\text{V} \pm 10\%$, $\text{trf} = 0.25\text{ns}$			0.3	ns
		$V_{CC} = 3.3\text{V} \pm 10\%$, $\text{trf} = 0.25\text{ns}$			0.3	ns
t_{SKD3}	Differential Part to Part Skew ⁽⁵⁾	$V_{CC} = 1.8\text{V} \pm 10\%$, $\text{trf} = 0.25\text{ns}$			3.0	ns
		$V_{CC} = 2.5\text{V} \pm 10\%$, $\text{trf} = 0.25\text{ns}$			1.7	ns
		$V_{CC} = 3.3\text{V} \pm 10\%$, $\text{trf} = 0.25\text{ns}$			1.2	ns
t_R	Rise Time	$V_{CC} = 1.8\text{V}$	250	500	740	ps
		$V_{CC} = 2.5\text{V}$	250	390	740	ps
		$V_{CC} = 3.3\text{V}$	250	450	740	ps
t_F	Fall Time	$V_{CC} = 1.8\text{V}$	250	560	740	ps
		$V_{CC} = 2.5\text{V}$	250	360	740	ps
		$V_{CC} = 3.3\text{V}$	250	400	740	ps
f_{MAX}	Maximum Operating Frequency ⁽¹¹⁾		300			MHz

- (1) C_L includes probe and jig capacitance.
- (2) Generator waveform for all tests unless otherwise specified: $f = 1\text{MHz}$, $Z_O = 50\Omega$, t_r and t_f (0% to 100%) $\leq 3\text{ns}$ for R_{IN} .
- (3) t_{SKD1} is the magnitude difference in differential propagation delay time between the positive-going-edge and the negative-going-edge of the same channel.
- (4) t_{SKD2} is the differential channel-to-channel skew of any event on the same device. This specification applies to devices having multiple receivers within the integrated circuit.
- (5) t_{SKD3} , part to part skew, is the differential channel-to-channel skew of any event between devices. This specification applies to devices at the same V_{CC} and within 5°C of each other within the operating temperature range.
- (6) f_{MAX} generator input conditions: $t_r = t_f < 1\text{ns}$ (0% to 100%), 50% duty cycle, differential (1.05V to 1.35 peak to peak). Output criteria: 60%/40% duty cycle, V_{OL} (max), V_{OH} (min), load = 15pF (stray plus probes).

5.7 Typical Characteristics

$T_A = 25^\circ\text{C}$, Load = 5pF (unless otherwise notes)

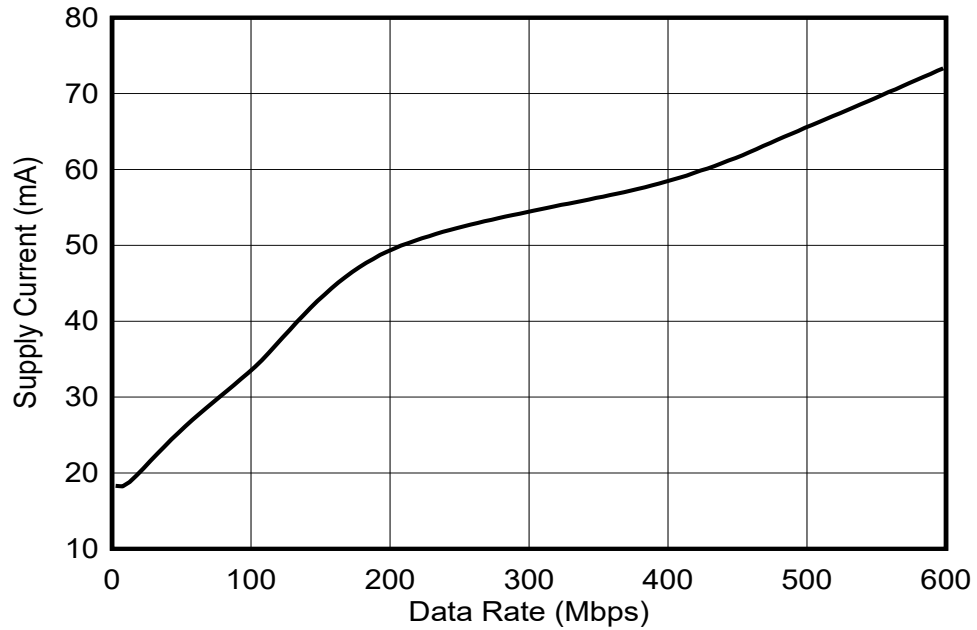

☒ 5-1. Power Supply Current vs Data Rate ($V_{CC} = 1.8\text{V}$, 2 Channels)

6 Parameter Measurement Information

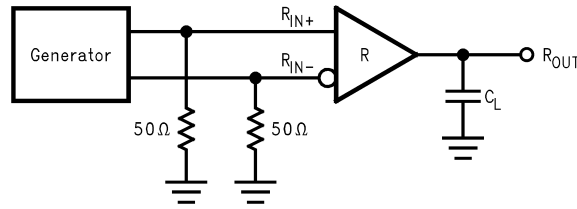

☒ 6-1. Receiver Propagation Delay and Transition Time Test Circuit

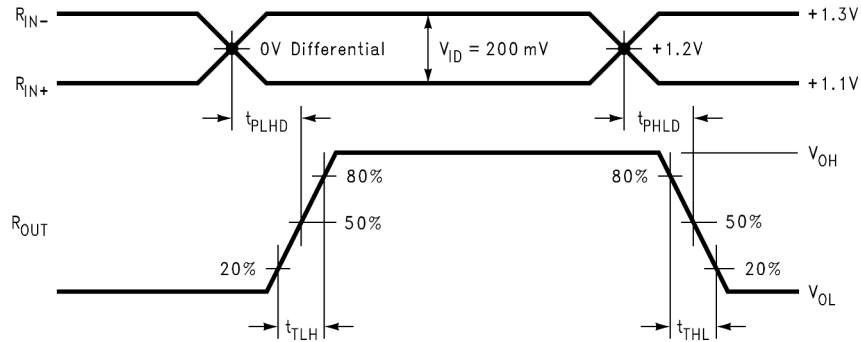

☒ 6-2. Receiver Propagation Delay and Transition Time Waveforms

7 Detailed Description

7.1 Overview

 8-1 shows how LVDS drivers and receivers are intended to be used primarily in a simple point-to-point configuration. This configuration provides a clean signaling environment for the fast edge rates of the drivers. The receiver is connected to the source through a impedance controlled 100Ω differential PCB traces. Use a termination resistor of 100Ω and place it as close to the receiver input pins as possible. The termination resistor converts the driver output (current mode) into a voltage that is detected by the receiver.

7.2 Functional Block Diagram

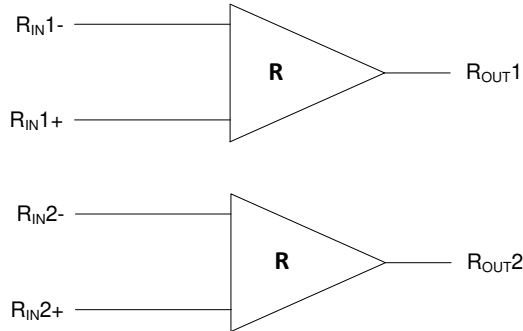

7.3 Feature Description

The DS90LVRA2-Q1 differential line receiver is capable of detecting signals as low as 100mV over a common-mode range of $-4V$ to $5V$ (V_{CC} at 3.3V). The common voltage range is related to the LVDS driver offset voltage, which is typically +1.2V. The differential signal from the LVDS driver is centered around the +1.2V offset voltage and may shift around this center point. The shifting may be the result of a ground potential difference between the driver's ground reference and the receiver's ground reference, the common-mode effects of coupled noise, or a combination of the two. The AC parameters of both receiver input pins are optimized for a recommended operating input voltage range of +0V to +3V (measured from each pin to ground).

7.4 Device Functional Modes

表 7-1. Truth Table

INPUTS ⁽¹⁾	OUTPUT
$V_{ID} \geq 100mV$	H
$V_{ID} \leq -100mV$	L
$-100mV \leq V_{ID} \leq 100mV$	Undetermined

(1) $V_{ID} = [R_{IN+}] - [R_{IN-}]$

8 Application and Implementation

注

Information in the following applications sections is not part of the TI component specification, and TI does not warrant its accuracy or completeness. TI's customers are responsible for determining suitability of components for their purposes. Customers should validate and test their design implementation to confirm system functionality.

8.1 Application Information

For general application guidelines and hints about LVDS drivers and receivers, refer to the [LVDS application notes and design guides](#).

8.2 Typical Application



図 8-1. Balanced System Point-to-Point Application

8.2.1 Design Requirements

When using LVDS devices, it is important to specify controlled impedance PCB traces. All components of the transmission media must have a matched differential impedance of 100Ω and must not introduce major impedance discontinuities.

8.2.2 Detailed Design Procedure

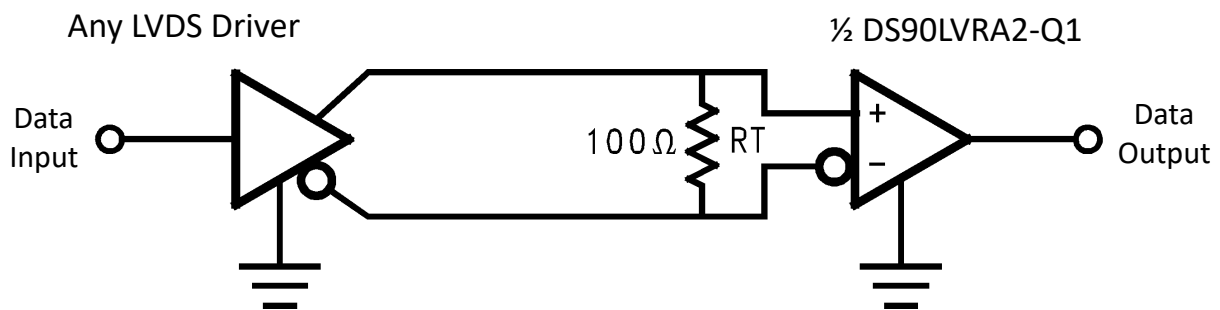
8.2.2.1 Power Decoupling Recommendations

Bypass capacitors must be used on power pins. It is recommended to use surface mount high frequency ceramic 0.1μF and 0.01μF capacitors in parallel at the power supply pin with the smallest value capacitor closest to the device supply pin. Additional scattered capacitors over the printed circuit board will improve decoupling. Multiple vias should be used to connect the decoupling capacitors to the power planes. A 10μF (35V) or greater solid tantalum capacitor should be connected at the power entry point on the printed circuit board between the supply and ground.

8.2.2.2 Termination

Use a termination resistor that best matches the differential impedance or the transmission line. The resistor should be between 90Ω and 110Ω. Remember that the current mode outputs need the termination resistor to generate the differential voltage. LVDS will not work correctly without resistor termination. Typically, connecting a single resistor across the pair at the receiver end will suffice. Surface mount 1% resistors are the best

PCB stubs, component lead, and the distance from the termination to the receiver inputs should be minimized. The distance between the termination resistor and the receiver should be < 10mm (12mm maximum).

8.2.2.3 Input Failsafe Biasing

External pull up and pull down resistors may be used to provide enough of an offset to enable an input failsafe under open-circuit conditions. This configuration ties the positive LVDS input pin to V_{DD} through a pull up resistor and ties the negative LVDS input pin to GND by a pull down resistor. The pull up and pull down resistors should be in the 5k Ω to 15k Ω range to minimize loading and waveform distortion to the driver. Set the common-mode bias point to approximately 1.2V so that it is compatible with the internal circuitry. For more information, refer to application note AN-1194 [Failsafe Biasing of LVDS Interfaces](#).

8.2.2.4 Probing LVDS Transmission Lines

Always use high impedance (> 100k Ω), low capacitance (< 2pF) scope probes with a wide bandwidth (1GHz) scope. Improper probing will give deceiving results.

8.2.3 Application Curves

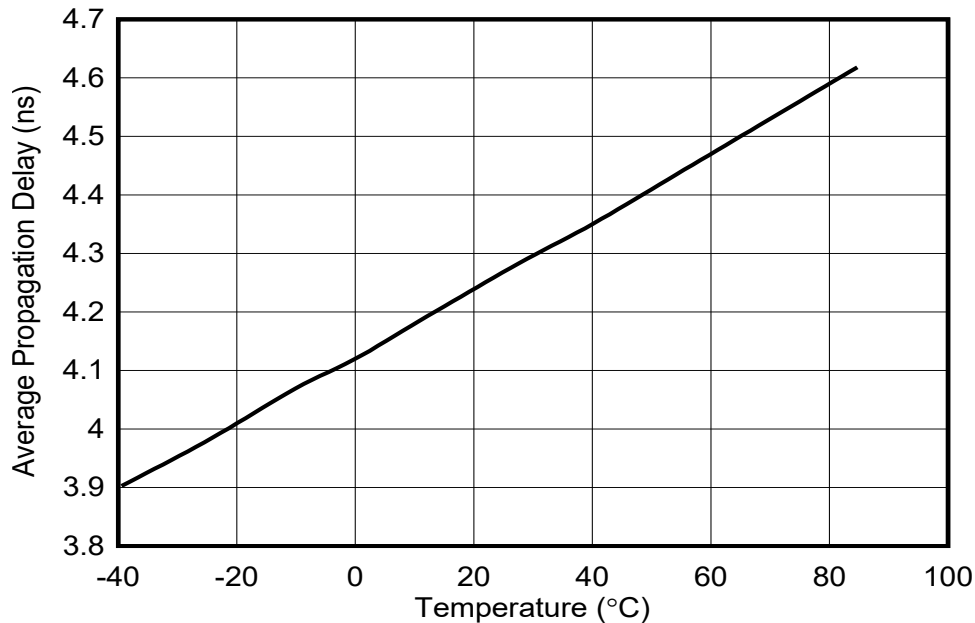

8-2. Propagation Delay vs Temperature ($V_{CC} = 1.8V$, Load = 10pF, Average of 2 Channels)

8.3 Power Supply Recommendations

Bypass capacitors must be used on power pins. TI recommends using high-frequency, ceramic, 0.1 μ F and 0.01 μ F capacitors in parallel at the power supply pin with the smallest value capacitor closest to the device supply pin. Additional scattered capacitors over the printed-circuit board improves decoupling. Multiple vias must be used to connect the decoupling capacitors to the power planes. A 10 μ F bulk capacitor, 35V (or greater) solid tantalum capacitor must be connected at the power entry point on the printed-circuit board between the supply and ground.

8.4 Layout

8.4.1 Layout Guidelines

8.4.1.1 Differential Traces

Use controlled impedance traces which match the differential impedance of your transmission trace and termination resistor. Run the differential pair trace lines as close together as possible as soon as they leave the IC (stubs should be < 10mm long). This will help eliminate reflections and make sure noise is coupled as common-mode. In fact, differential signals which are 1mm apart radiate far less noise than traces 3mm apart since magnetic field cancellation is much better with the closer traces. In addition, noise induced on the differential lines is much more likely to appear as common-mode, which is rejected by the receiver.

Match electrical lengths between traces to reduce skew. It is important to note: skew between the signals of a pair means a phase difference between signals, which destroys the magnetic field cancellation benefits of differential signals and EMI, will result. (Note that the velocity of propagation, $v = c/E_r$, where c (the speed of light) = 0.2997mm/ps or 0.0118in/ps). Do not rely solely on the auto-route function for differential traces. Carefully review dimensions to match differential impedance and provide isolation for the differential lines. Minimize the number of vias and other discontinuities on the line.

Avoid 90° turns (these cause impedance discontinuities). Use arcs or 45° bevels.

Within a pair of traces, the distance between the two traces should be minimized to maintain common-mode rejection of the receivers. On the printed circuit board, this distance should remain constant to avoid discontinuities in differential impedance. Minor violations at connection points are allowed.

8.4.1.2 PC Board Considerations

Use at least 4 PCB board layers (top to bottom): LVDS signals, ground, power, and TTL signals.

Isolate TTL signals from LVDS signals, otherwise the TTL signals may couple onto the LVDS lines. It is best to put TTL and LVDS signals on different layers, which are isolated by one or more power or ground planes.

8.4.2 Layout Examples

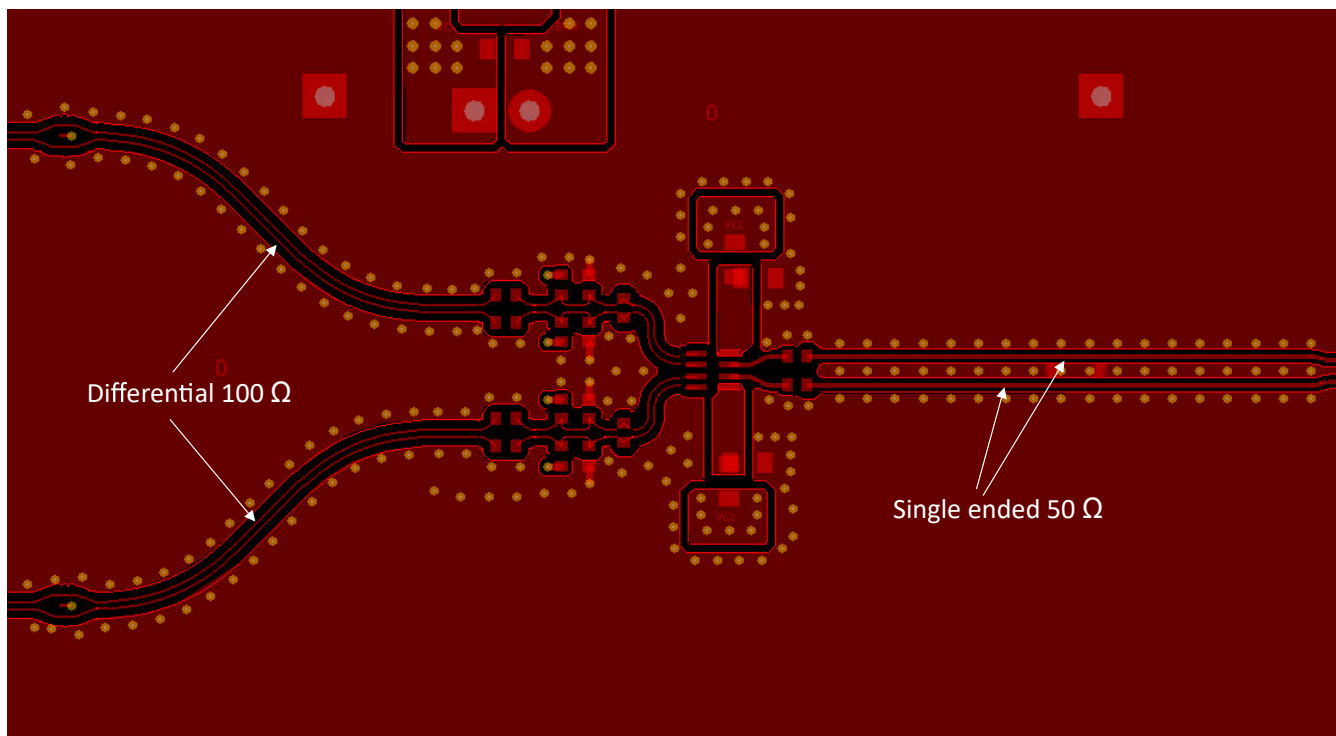

☒ 8-3. EVM Layout

9 Device and Documentation Support

9.1 Documentation Support

9.1.1 Related Documentation

For related documentation, see the following:

- Texas Instruments, [Fail-safe Biasing of LVDS Interfaces application note](#)

9.2 ドキュメントの更新通知を受け取る方法

ドキュメントの更新についての通知を受け取るには、www.tij.co.jp のデバイス製品フォルダを開いてください。[通知] をクリックして登録すると、変更されたすべての製品情報に関するダイジェストを毎週受け取ることができます。変更の詳細については、改訂されたドキュメントに含まれている改訂履歴をご覧ください。

9.3 サポート・リソース

テキサス・インスツルメンツ E2E™ サポート・フォーラムは、エンジニアが検証済みの回答と設計に関するヒントをエキスパートから迅速かつ直接得ることができる場所です。既存の回答を検索したり、独自の質問をしたりすることで、設計に必要な支援を迅速に得ることができます。

リンクされているコンテンツは、各寄稿者により「現状のまま」提供されるものです。これらはテキサス・インスツルメンツの仕様を構成するものではなく、必ずしもテキサス・インスツルメンツの見解を反映したものではありません。テキサス・インスツルメンツの[使用条件](#)を参照してください。

9.4 Trademarks

テキサス・インスツルメンツ E2E™ is a trademark of Texas Instruments.

すべての商標は、それぞれの所有者に帰属します。

9.5 静電気放電に関する注意事項



この IC は、ESD によって破損する可能性があります。テキサス・インスツルメンツは、IC を取り扱う際には常に適切な注意を払うことを推奨します。正しい取り扱いおよび設置手順に従わない場合、デバイスを破損するおそれがあります。

ESD による破損は、わずかな性能低下からデバイスの完全な故障まで多岐にわたります。精密な IC の場合、パラメータがわずかに変化するだけで公表されている仕様から外れる可能性があるため、破損が発生しやすくなっています。

9.6 用語集

[テキサス・インスツルメンツ用語集](#)

この用語集には、用語や略語の一覧および定義が記載されています。

10 Revision History

DATE	REVISION	NOTES
December 2023	*	Initial Release

11 Mechanical, Packaging, and Orderable Information

The following pages include mechanical, packaging, and orderable information. This information is the most current data available for the designated devices. This data is subject to change without notice and revision of this document. For browser-based versions of this data sheet, refer to the left-hand navigation.

PACKAGING INFORMATION

Orderable Device	Status (1)	Package Type	Package Drawing	Pins	Package Qty	Eco Plan (2)	Lead finish/ Ball material (6)	MSL Peak Temp (3)	Op Temp (°C)	Device Marking (4/5)	Samples
D9LVRA2DEMRQ1	ACTIVE	WSON	DEM	8	3000	RoHS & Green	NIPDAU	Level-1-260C-UNLIM	-40 to 125	LR2Q	Samples

(1) The marketing status values are defined as follows:

ACTIVE: Product device recommended for new designs.

LIFEBUY: TI has announced that the device will be discontinued, and a lifetime-buy period is in effect.

NRND: Not recommended for new designs. Device is in production to support existing customers, but TI does not recommend using this part in a new design.

PREVIEW: Device has been announced but is not in production. Samples may or may not be available.

OBSELETE: TI has discontinued the production of the device.

(2) **RoHS:** TI defines "RoHS" to mean semiconductor products that are compliant with the current EU RoHS requirements for all 10 RoHS substances, including the requirement that RoHS substance do not exceed 0.1% by weight in homogeneous materials. Where designed to be soldered at high temperatures, "RoHS" products are suitable for use in specified lead-free processes. TI may reference these types of products as "Pb-Free".

RoHS Exempt: TI defines "RoHS Exempt" to mean products that contain lead but are compliant with EU RoHS pursuant to a specific EU RoHS exemption.

Green: TI defines "Green" to mean the content of Chlorine (Cl) and Bromine (Br) based flame retardants meet JS709B low halogen requirements of <=1000ppm threshold. Antimony trioxide based flame retardants must also meet the <=1000ppm threshold requirement.

(3) MSL, Peak Temp. - The Moisture Sensitivity Level rating according to the JEDEC industry standard classifications, and peak solder temperature.

(4) There may be additional marking, which relates to the logo, the lot trace code information, or the environmental category on the device.

(5) Multiple Device Markings will be inside parentheses. Only one Device Marking contained in parentheses and separated by a "-" will appear on a device. If a line is indented then it is a continuation of the previous line and the two combined represent the entire Device Marking for that device.

(6) Lead finish/Ball material - Orderable Devices may have multiple material finish options. Finish options are separated by a vertical ruled line. Lead finish/Ball material values may wrap to two lines if the finish value exceeds the maximum column width.

Important Information and Disclaimer:The information provided on this page represents TI's knowledge and belief as of the date that it is provided. TI bases its knowledge and belief on information provided by third parties, and makes no representation or warranty as to the accuracy of such information. Efforts are underway to better integrate information from third parties. TI has taken and continues to take reasonable steps to provide representative and accurate information but may not have conducted destructive testing or chemical analysis on incoming materials and chemicals. TI and TI suppliers consider certain information to be proprietary, and thus CAS numbers and other limited information may not be available for release.

In no event shall TI's liability arising out of such information exceed the total purchase price of the TI part(s) at issue in this document sold by TI to Customer on an annual basis.

OTHER QUALIFIED VERSIONS OF DS90LVRA2-Q1 :

- Catalog : [DS90LVRA2](#)

NOTE: Qualified Version Definitions:

- Catalog - TI's standard catalog product

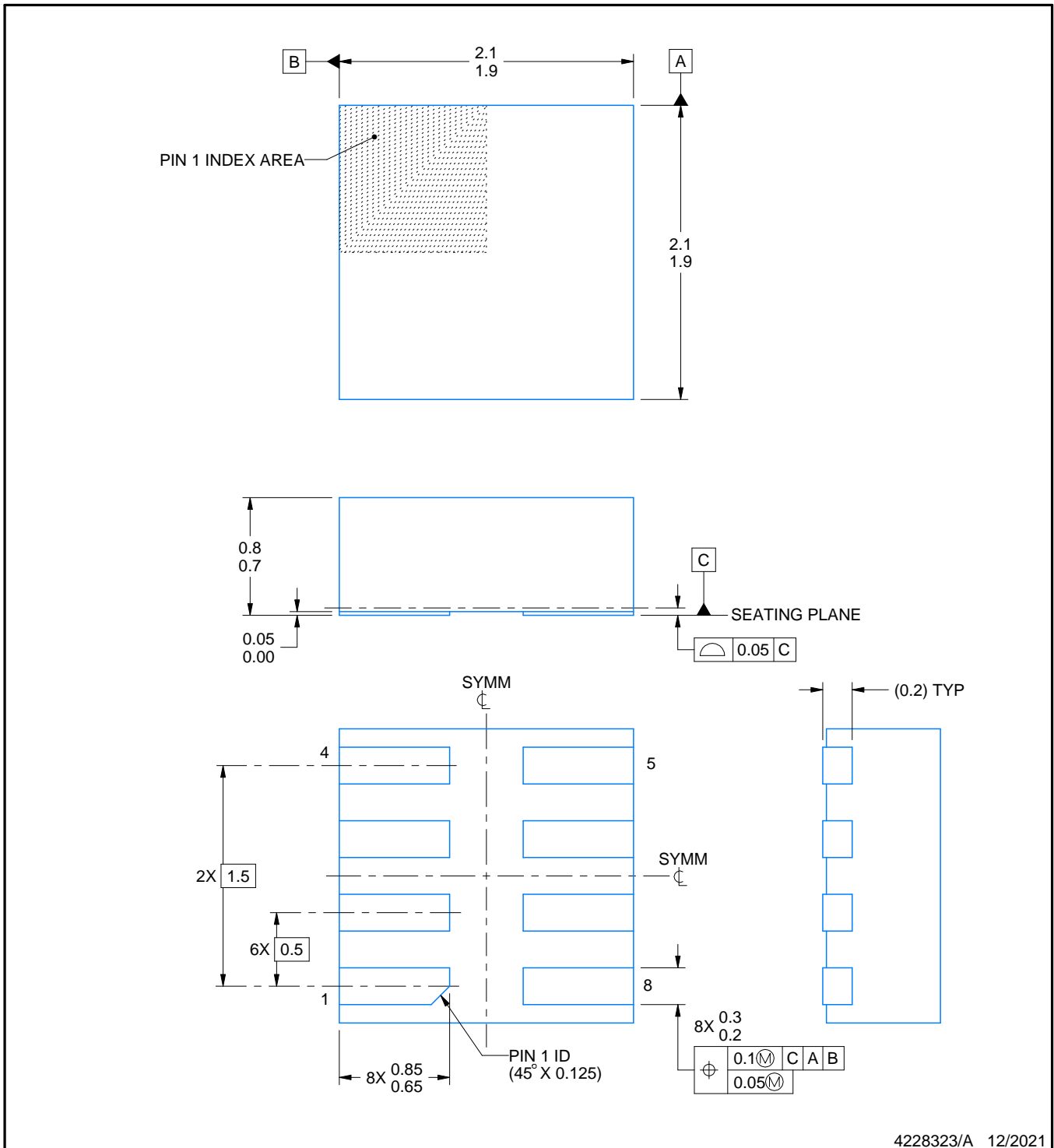
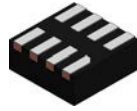

4228323/A 12/2021

NOTES:

1. All linear dimensions are in millimeters. Any dimensions in parenthesis are for reference only. Dimensioning and tolerancing per ASME Y14.5M.
2. This drawing is subject to change without notice.

EXAMPLE BOARD LAYOUT

DEM0008A

WSON - 0.8 mm max height

PLASTIC SMALL OUTLINE - NO LEAD

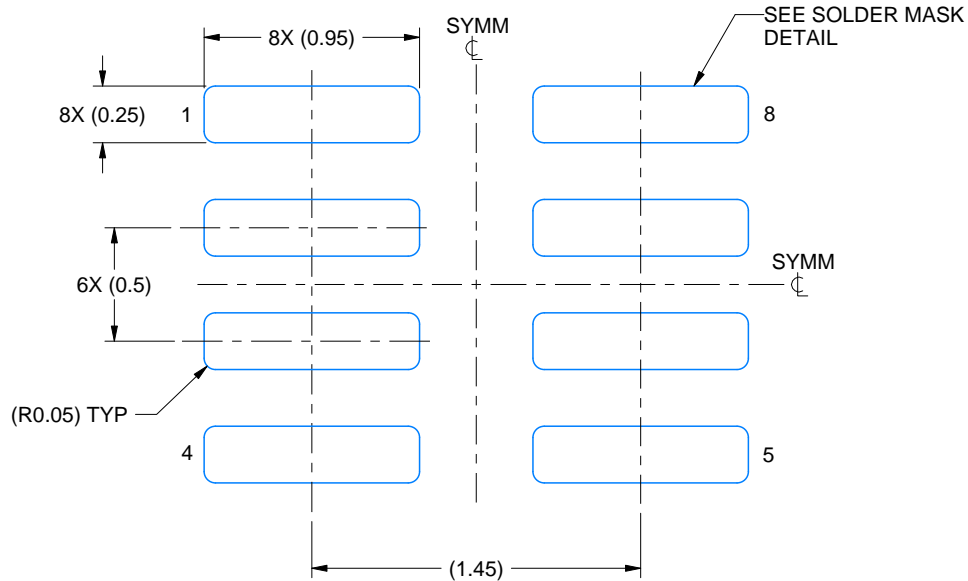

LAND PATTERN EXAMPLE
EXPOSED METAL SHOWN
SCALE: 30X

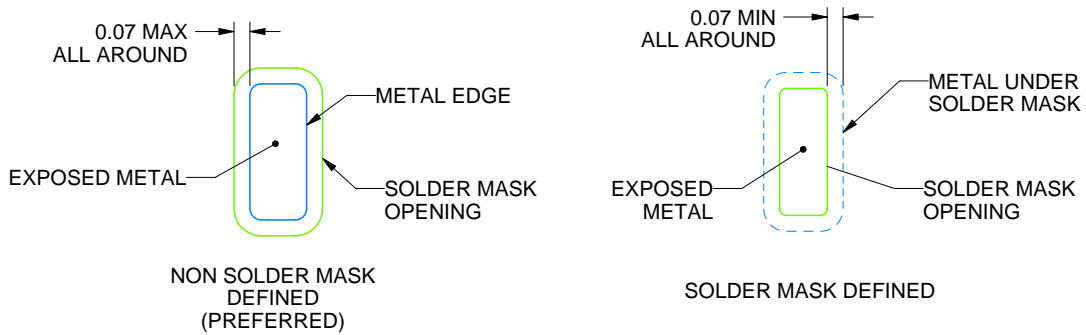

SOLDER MASK DETAILS

4228323/A 12/2021

NOTES: (continued)

- This package is designed to be soldered to a thermal pad on the board. For more information, see Texas Instruments literature number SLUA271 (www.ti.com/lit/slua271).

EXAMPLE STENCIL DESIGN

DEM0008A

WSON - 0.8 mm max height

PLASTIC SMALL OUTLINE - NO LEAD

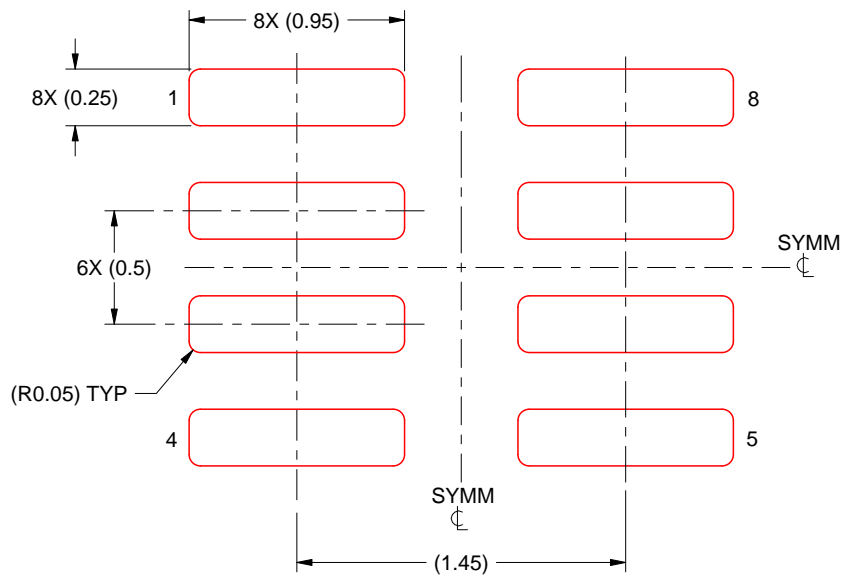

SOLDER PASTE EXAMPLE
BASED ON 0.125 MM THICK STENCIL
SCALE: 30X

4228323/A 12/2021

NOTES: (continued)

4. Laser cutting apertures with trapezoidal walls and rounded corners may offer better paste release. IPC-7525 may have alternate design recommendations.

重要なお知らせと免責事項

TI は、技術データと信頼性データ(データシートを含みます)、設計リソース(リファレンス・デザインを含みます)、アプリケーションや設計に関する各種アドバイス、Web ツール、安全性情報、その他のリソースを、欠陥が存在する可能性のある「現状のまま」提供しており、商品性および特定目的に対する適合性の黙示保証、第三者の知的財産権の非侵害保証を含むいかなる保証も、明示的または黙示的にかかわらず拒否します。

これらのリソースは、TI 製品を使用する設計の経験を積んだ開発者への提供を意図したものです。(1) お客様のアプリケーションに適した TI 製品の選定、(2) お客様のアプリケーションの設計、検証、試験、(3) お客様のアプリケーションに該当する各種規格や、その他のあらゆる安全性、セキュリティ、規制、または他の要件への確実な適合に関する責任を、お客様のみが単独で負うものとし、

上記の各種リソースは、予告なく変更される可能性があります。これらのリソースは、リソースで説明されている TI 製品を使用するアプリケーションの開発の目的でのみ、TI はその使用をお客様に許諾します。これらのリソースに関して、他の目的で複製することや掲載することは禁止されています。TI や第三者の知的財産権のライセンスが付与されている訳ではありません。お客様は、これらのリソースを自身で使用した結果発生するあらゆる申し立て、損害、費用、損失、責任について、TI およびその代理人を完全に補償するものとし、TI は一切の責任を拒否します。

TI の製品は、[TI の販売条件](#)、または [ti.com](#) やかかる TI 製品の関連資料などのいずれかを通じて提供する適用可能な条項の下で提供されています。TI がこれらのリソースを提供することは、適用される TI の保証または他の保証の放棄の拡大や変更を意味するものではありません。

お客様がいかなる追加条項または代替条項を提案した場合でも、TI はそれらに異議を唱え、拒否します。

郵送先住所 : Texas Instruments, Post Office Box 655303, Dallas, Texas 75265
Copyright © 2024, Texas Instruments Incorporated