

HD3SS212 5.4Gbps、DisplayPort 1.2 対応、2 対 1 差動スイッチ

1 特長

- DisplayPort 1.2 電気規格に対応
- 最大 5.4Gbps のデータ・レートをサポートする 2:1 スイッチング
- HPD スイッチングをサポート
- 5.4GHz を超える広い -3dB 差動帯域幅
- 優れた動的特性 (2.7GHz 時)
 - クロストーク = -50dB
 - 絶縁 = -22dB
 - 挿入損失 = -1.4dB
 - 反射損失 = -11dB
 - 最大ビット間スキュー = 4ps
- VDD 動作範囲: 3.3V ±10%
- 小型の 5mm × 5mm × 1mm、48 ボールの nFBGA パッケージ
- 出力イネーブル (OE) ピンは、消費電力を節約するためにスイッチをディセーブルします
- 消費電力
 - HD3SS212 < 10mW (OE = L の場合、スタンバイ時: 30µW 未満)

2 アプリケーション

- PC / ノート PC
- タブレット
- ネットワーク接続の周辺機器とプリンタ

3 概要

HD3SS212 デバイスは高速パッシブ・スイッチで、2 つのフル DisplayPort 4 レーン・ポートを、アプリケーション内で 2 つのソースのうちの 1 つから 1 つのターゲット位置に切り替えることができます。HD3SS212 が補助 (AUX) 信号とホット・プラグ検出 (HPD) 信号のスイッチングにも対応する DisplayPort アプリケーション向け。HPD パスは、HPDC ラインに 125kΩ のプルダウン抵抗を必要とするバッファです。

代表的なアプリケーションの 1 つは、1 つの DisplayPort シンクを駆動する必要のある 2 つの GPU を搭載したマザーボードです。GPU は Dx_SEL ピンで選択します。HD3SS212 は 48 ボールの bFBGA パッケージで供給され、-40°C ~ 105°C の産業用温度範囲全体にわたって 3.3V の単一電源電圧で動作することが規定されています。

製品情報 (1)

部品番号	パッケージ	本体サイズ (公称)
HD3SS212	nFBGA (48)	5.00mm × 5.00mm

- (1) 利用可能なすべてのパッケージについては、このデータシートの末尾にある注文情報を参照してください。

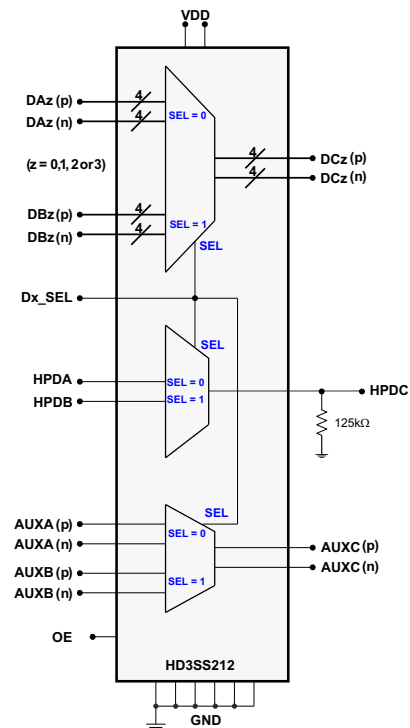

機能ブロック図



Table of Contents

1 特長.....	1	8.2 Functional Block Diagram.....	10
2 アプリケーション.....	1	8.3 Feature Description.....	10
3 概要.....	1	8.4 Device Functional Modes.....	11
4 Revision History.....	2	9 Application and Implementation.....	12
5 Pin Configuration and Function.....	3	9.1 Application Information.....	12
6 Specifications.....	5	9.2 Typical Application.....	13
6.1 Absolute Maximum Ratings.....	5	10 Layout.....	16
6.2 ESD Ratings.....	5	10.1 Layout Guidelines.....	16
6.3 Recommended Operating Conditions.....	5	10.2 Layout Example.....	16
6.4 Thermal Information.....	5	11 Device and Documentation Support.....	17
6.5 Electrical Characteristics.....	6	11.1 Receiving Notification of Documentation Updates..	17
6.6 Typical Characteristics.....	7	11.2 Community Resource.....	17
7 Parameter Measurement Information.....	8	11.3 Trademarks.....	17
7.1 Test Timing Diagrams.....	8	12 Mechanical, Packaging, and Orderable Information.....	17
8 Detailed Description.....	10		
8.1 Overview.....	10		

4 Revision History

資料番号末尾の英字は改訂を表しています。その改訂履歴は英語版に準じています。

Changes from Revision C (October 2016) to Revision D (December 2020)

Page

• 注: MicroStar Jr. BGA パッケージのデバイスは、ラミネート nFBGA パッケージを使用して再設計されています。この nFBGA パッケージは、データシート上、同等の電気的性能を実現します。また、MicroStar Jr. BGA と同等のフットプリントを実現しています。生産中止となったパッケージ識別子に代わる新しいパッケージ識別子が、データシート全体を通して更新されます。.....	1
• u*jr BGA を nFBGA に変更.....	1
• Changed u*jr ZQE to nFBGA ZXH. Updated thermal information.....	5
• Corrected typo from HD3SS3412 to HD3SS212.....	16

Changes from Revision B (January 2014) to Revision C (October 2016)

Page

• 「製品情報」表、「ESD 定格」表、「機能説明」セクション、「デバイスの機能モード」セクション、「アプリケーションと実装」セクション、「電源に関する推奨事項」セクション、「レイアウト」セクション、「デバイスおよびドキュメントのサポート」セクション、「メカニカル、パッケージ、および注文情報」セクションを追加.....	1
• 「注文情報」表を削除データシートの末尾にある POA を参照。.....	1

Changes from Revision A (March 2012) to Revision B (January 2014)

Page

• ドキュメント全体で OE を OE に変更.....	1
------------------------------	---

Changes from Revision * (December 2011) to Revision A (March 2012)

Page

• 「概要」の「産業用温度範囲: -40°C~85°C」を「産業用温度範囲: -40°C~105°C」に変更.....	1
• Added Operating Temperature to the Abs Max Table.....	5
• Changed the Operating free-air temperature From MAX = 85°C To: 105°C.....	5
• Changed the values of ψ_{JT} and ψ_{JB} in the Thermal Information table.....	5
• Changed the MAX value of Leakage current (Dx_SEL), VDD = 0 V From: 8 μ A To: 10 μ A.....	6

5 Pin Configuration and Function

	1	2	3	4	5	6	7	8	9
A	Dx_SEL	VDD		DA0(n)	DA1(n)	DA2(n)		DA3(p)	DA3(n)
B	DC0(n)	DC0(p)	GND	DA0(p)	DA1(p)	DA2(p)	OE	DB0(p)	DB0(n)
C		NC						GND	
D	DC1(n)	DC1(p)						DB1(p)	DB1(n)
E	DC2(n)	DC2(p)						DB2(p)	DB2(n)
F	DC3(n)	DC3(p)						DB3(p)	DB3(n)
G		GND						GND	
H	AUXC(n)	AUXC(p)	HPDB	GND	NC	AUXB(p)	GND	NC	AUXA(p)
J	HPDC	HPDA		VDD	NC	AUXB(n)		NC	AUXA(n)

表 5-1. Pin Functions

PIN	PIN NAME	I/O	DESCRIPTION
A1	Dx_SEL	Control I	High Speed Port Selection Control Pins
B4 A4	DA0(p) DA0(n)	I/O	Port A, Channel 0, High Speed Positive Signal Port A, Channel 0, High Speed Negative Signal
B5 A5	DA1(p) DA1(n)	I/O	Port A, Channel 1, High Speed Positive Signal Port A, Channel 1, High Speed Negative Signal
B6 A6	DA2(p) DA2(n)	I/O	Port A, Channel 2, High Speed Positive Signal Port A, Channel 2, High Speed Negative Signal
A8 A9	DA3(p) DA3(n)	I/O	Port A, Channel 3, High Speed Positive Signal Port A, Channel 3, High Speed Negative Signal
B8 B9	DB0(p) DB0(n)	I/O	Port B, Channel 0, High Speed Positive Signal Port B, Channel 0, High Speed Negative Signal
D8 D9	DB1(p) DB1(n)	I/O	Port B, Channel 1, High Speed Positive Signal Port B, Channel 1, High Speed Negative Signal
E8 E9	DB2(p) DB2(n)	I/O	Port B, Channel 2, High Speed Positive Signal Port B, Channel 2, High Speed Negative Signal
F8 F9	DB3(p) DB3(n)	I/O	Port B, Channel 3, High Speed Positive Signal Port B, Channel 3, High Speed Negative Signal
B2 B1	DC0(p) DC0(n)	I/O	Port C, Channel 0, High Speed Positive Signal Port C, Channel 0, High Speed Negative Signal
D2 D1	DC1(p) DC1(n)	I/O	Port C, Channel 1, High Speed Positive Signal Port C, Channel 1, High Speed Negative Signal
E2 E1	DC2(p) DC2(n)	I/O	Port C, Channel 2, High Speed Positive Signal Port C, Channel 2, High Speed Negative Signal
F2 F1	DC3(p) DC3(n)	I/O	Port C, Channel 3, High Speed Positive Signal Port C, Channel 3, High Speed Negative Signal
H9 J9	AUXA(p) AUXA(n)	I/O	Port A AUX Positive Signal Port A AUX Negative Signal

表 5-1. Pin Functions (continued)

PIN	PIN NAME	I/O	DESCRIPTION
H6 J6	AUXB(p) AUXB(n)	I/O	Port B AUX Positive Signal Port B AUX Negative Signal
H2 H1	AUXC(p) AUXC(n)	I/O	Port C AUX Positive Signal Port C AUX Negative Signal
J2, H3, J1	HPDA/B/C	I/O	Port A/B/C Hot Plug Detect
B7	OE	I	Output Enable
A2, J4	VDD	Supply	3.3V Positive power supply voltage
B3, C8, G2, G8, H4, H7	GND	Supply	Negative power supply voltage
C2, H5, H8, J5, J8	NC		Electrically not connected

6 Specifications

6.1 Absolute Maximum Ratings

over operating free-air temperature range (unless otherwise noted) ⁽¹⁾ ⁽²⁾

		MIN	MAX	UNIT
Supply voltage range ⁽³⁾	VDD	-0.5	4	V
Voltage range	Differential I/O	-0.5	4	V
	Control pin	-0.5	VCC +0.5	V
Operating free-air temperature		-40	105	°C
Continuous power dissipation		See セクション 6.4		
Storage temperature		-55	125	°C

- (1) Stresses beyond those listed under *absolute maximum ratings* may cause permanent damage to the device. These are stress ratings only and functional operation of the device at these or any conditions beyond those indicated under *recommended operating conditions* is not implied. Exposure to absolute-maximum-rated conditions for extended periods may affect device reliability.
- (2) All voltage values, except differential voltages, are with respect to network ground terminal.
- (3) Tested in accordance with JEDEC Standard 22, Test Method A114-B

6.2 ESD Ratings

		VALUE	UNIT
V _(ESD) Electrostatic discharge	Human-body model (HBM) ⁽¹⁾	±4000	V
	Charged-device model (CDM) ⁽²⁾	±1000	

- (1) Tested in accordance with JEDEC Standard 22, Test Method C101-A
- (2) Tested in accordance with JEDEC Standard 22, Test Method A115-A

6.3 Recommended Operating Conditions

Nominal values for all parameters are at V_{CC} = 3.3V and T_A = 25°C, all temperature limits are specified by design

PARAMETER	CONDITIONS	MIN	NOM	MAX	UNIT
V _{DD} Supply voltage		3.0	3.3	3.6	V
V _{IH} Input high voltage	Control Pins, Signal Pins (Dx_SEL, OE) (HPDC, 5V Tolerant)	2.0		VDD	V
V _{IL} Input low voltage	Control Pins, Signal Pins (Dx_SEL, OE, HPDC)	-0.1		0.8	V
V _{I/O_Diff} Differential voltage (Dx, AUXx)	Switch I/O diff voltage	0		1.8	V _{pp}
V _{I/O_CM} Common voltage (Dx, AUXx)	Switch I/O common mode voltage	0		2.0	V
Operating free-air temperature		-40		105	°C

6.4 Thermal Information

THERMAL METRIC ⁽¹⁾		HD3SS212	UNIT
		nFBGA (ZXH)	
		48-Ball	
θ _{JA}	Junction-to-ambient thermal resistance	64.9	°C/W
θ _{JCtop}	Junction-to-case (top) thermal resistance	28.7	°C/W
θ _{JB}	Junction-to-board thermal resistance	36.4	°C/W
ψ _{JT}	Junction-to-top characterization parameter	1.0	°C/W
ψ _{JB}	Junction-to-board characterization parameter	36.1	°C/W

- (1) For more information about traditional and new thermal metrics, see the [Semiconductor and IC Package Thermal Metrics](#) application report.

6.5 Electrical Characteristics

under recommended operating conditions

PARAMETER		TEST CONDITIONS	MIN	TYP	MAX	UNIT
DEVICE PARAMETERS						
I_{IH}	Input high current (Dx_SEL)	VDD = 3.6 V, VIN = VDD		3	10	μ A
I_{IL}	Input low current (Dx_SEL)	VDD = 3.6 V, VIN = GND		0.01	1	μ A
I_{LK}	Leakage current (Dx_SEL)	VDD = 3.3 V, Vi = 2V, OE = 3.3V		2	5	μ A
		VDD = 0 V, Vi = 2 V, OE = 3.3 V		6	10	
	Leakage current (HPDA)	VDD = 3.3 V, Vi = 2 V, OE = 3.3 V; Dx_SEL=3.3 V		0.01	2	
	Leakage current (HPDB)	VDD = 3.3 V, Vi = 2 V, OE = 3.3 V; Dx_SEL=GND		0.01	2	
I_{off}	Device shut down current	VDD = 3.6 V, OE = GND			5	μ A
I_{DD}	Supply current	VDD = 3.6 V, Dx_SELx = VCC/GND; Outputs floating		2.5	5	mA
DA, DB, DC HIGH SPEED SIGNAL PATH						
C_{ON}	Outputs ON capacitance	Vi = 0 V, Outputs open, Switch ON		1.5		pF
C_{OFF}	Outputs OFF capacitance	Vi = 0 V, Outputs open, Switch OFF		1		pF
R_{ON}	Output ON resistance	VDD = 3.3 V, VCM = 0.5V - 1.5 V, IO = -40 mA		6.5	10	Ω
ΔR_{ON}	On resistance match between pairs of the same channel	VDD = 3.3 V; -0.35V \leq Vi \leq 1.2 V; IO = -40 mA			1.5	Ω
R_{FLAT_ON}	On resistance flatness ($R_{ON(MAX)} - R_{ON(MAIN)}$)	VDD = 3.3 V; -0.35 V \leq Vi \leq 1.2 V		1.3		Ω
AUXx SIGNAL PATH						
C_{ON}	Outputs ON capacitance	Vi = 0 V, Outputs open, Switch ON		9		pF
C_{OFF}	Outputs OFF capacitance	Vi = 0 V, Outputs open, Switch OFF		3		pF
R_{ON}	Output ON resistance	VDD = 3.3 V, VCM = 0.5 V - 1.5 V, IO = -40 mA		7	12	Ω
DEVICE PARAMETERS (under recommended operating conditions; RL, Rsc = 50 Ω unless otherwise noted)						
t_{PD}	Switch propagation delay	Rsc and RL = 50 Ω , See Figure 7-2			200	ps
T_{on}	Dx_SEL -to-Switch Ton (Data and AUX)	Rsc and RL = 50 Ω , See Figure 7-1		175	250	ns
T_{off}	Dx_SEL -to-Switch Toff (Data and AUX)			175	250	
T_{on}	Dx_SEL -to-Switch Ton (HPD)	RL = 50 Ω , See Figure 7-1		275	350	ns
T_{off}	Dx_SEL -to-Switch Toff (HPD)			275	350	
$T_{SK(O)}$	Inter-pair output skew (CH-CH)	Rsc and RL = 1 k Ω , See Figure 7-2			50	ps
$T_{SK(b-b)}$	Intra-pair output skew (bit-bit)			1	4	
RL	Dx Differential return loss ⁽¹⁾	1.35 GHz, See Section 6.6		-17		dB
		2.7 GHz, See Section 6.6		-11		
X_{TALK}	Dx Differential crosstalk ⁽¹⁾	2.7 GHz		-50		
O_{IRR}	Dx Differential off-isolation ⁽¹⁾	2.7 GHz, See Section 6.6		-22		
I_L	Dx Differential insertion loss ⁽¹⁾	f = 1.35 GHz, See Section 6.6		-0.7		dB
		f = 2.7 GHz, See Section 6.6		-1.4		
		f = 5.4 GHz, See Section 6.6		-1.7		
	AUX Differential insertion loss ⁽¹⁾	f = 360 MHz		-1		dB

(1) For Return Loss, Crosstalk, Off-Isolation, and Insertion Loss values the data was collected on a Rogers material board with minimum length traces on the input and output of the device under test.

6.6 Typical Characteristics

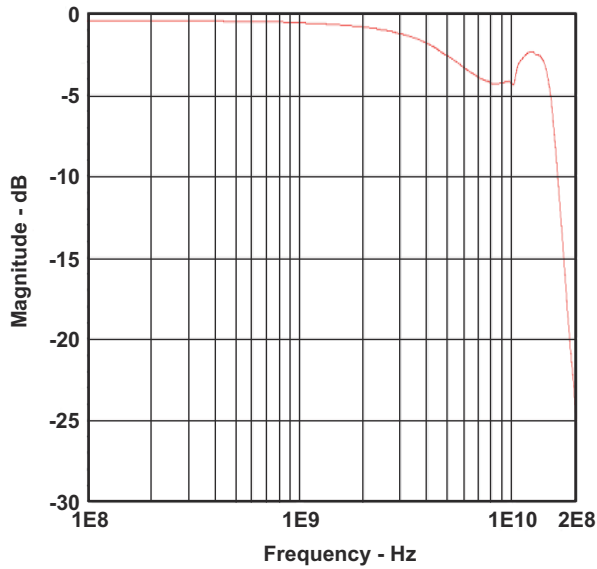

6-1. Insertion Loss and -3dB Bandwidth

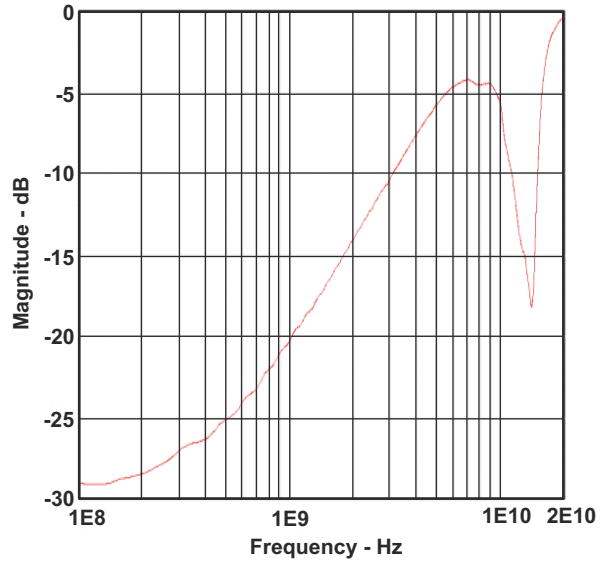

6-2. Return Loss

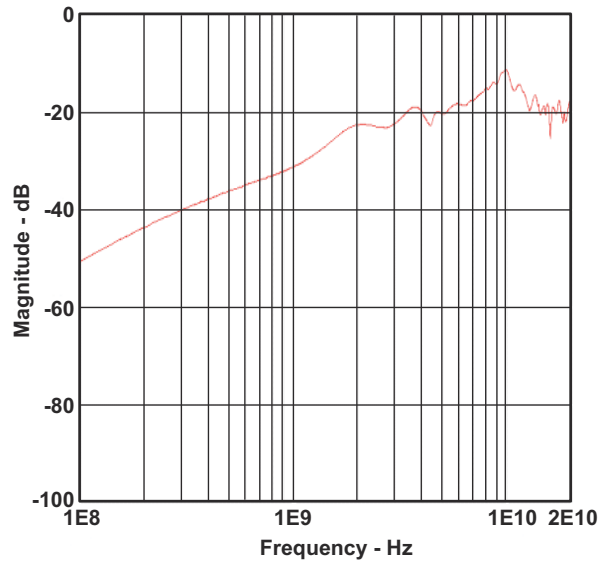

6-3. OF Isolation

7 Parameter Measurement Information

7.1 Test Timing Diagrams



图 7-1. Select to Switch T_{on} and T_{off}



7-2. Propagation Delay and Skew

8 Detailed Description

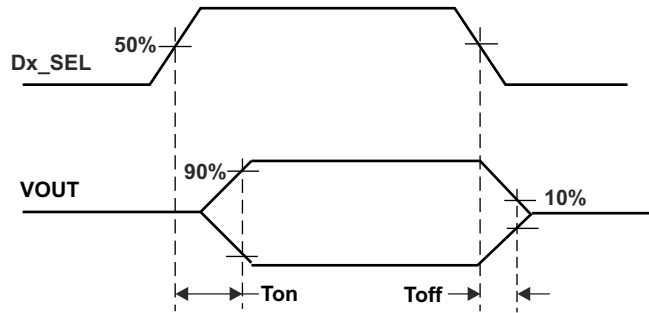
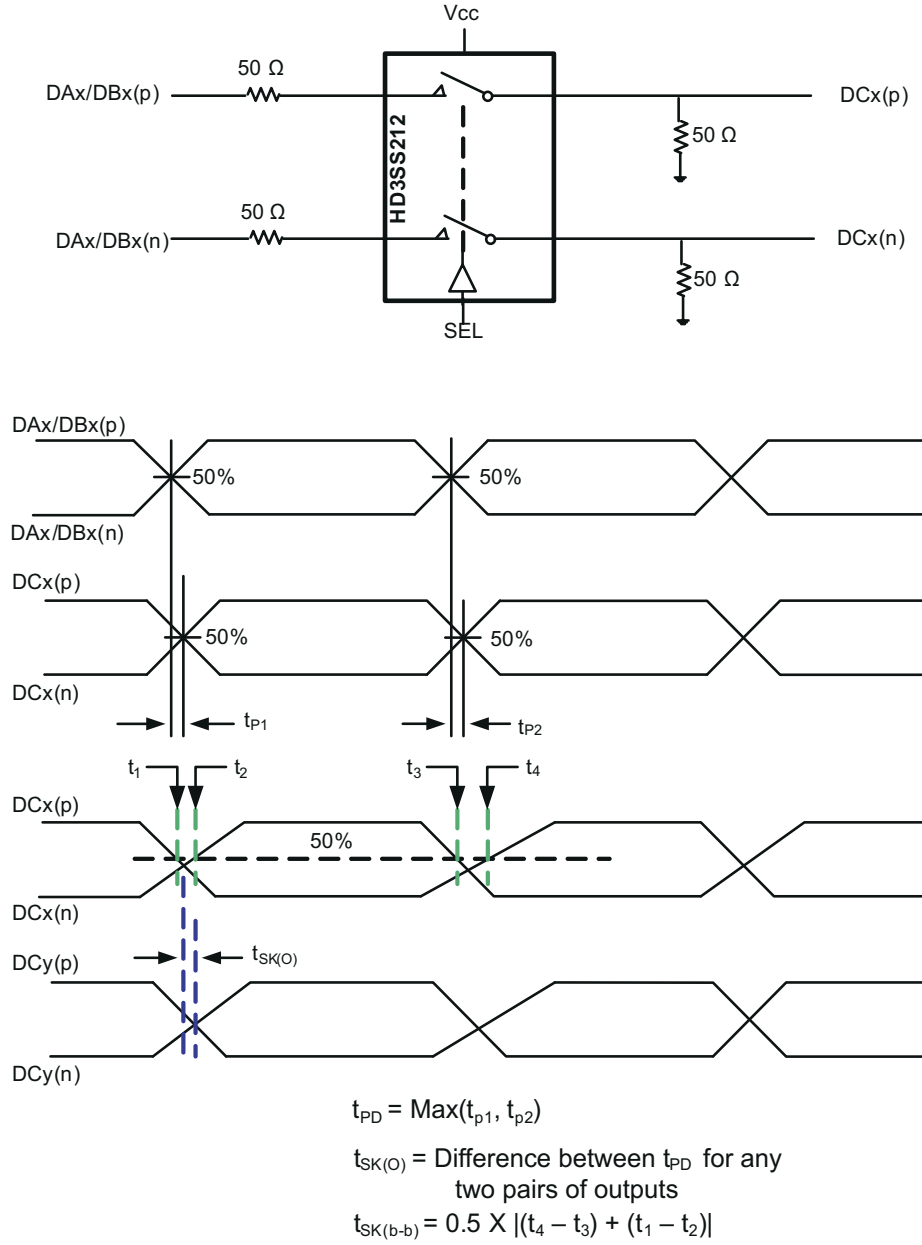
8.1 Overview

The HD3SS212 is a high-speed passive switch offered in an industry standard 48-pin u*BGA package available in a common footprint shared by several other vendors. The device is specified to operate from a single supply voltage of 3.3 V over the industrial temperature range of -40°C to 105°C.

The HD3SS212 is a generic 4-CH high-speed mux/demux type of switch that can be used for routing high-speed signals between two different locations on a circuit board. The HD3SS212 will also support several other high-speed data protocols with a differential amplitude of < 1800 mVpp and a common-mode voltage of < 2.0 V, as with USB 3.0 and DisplayPort 1.2. For Display Port Applications the HD3SS212 also supports switching of both the Auxiliary and Hot Plug Detect signals.

The device's High Speed Port Selection Control input (Dx_SEL) pin can easily be controlled by an available GPIO pin within a system.

8.2 Functional Block Diagram

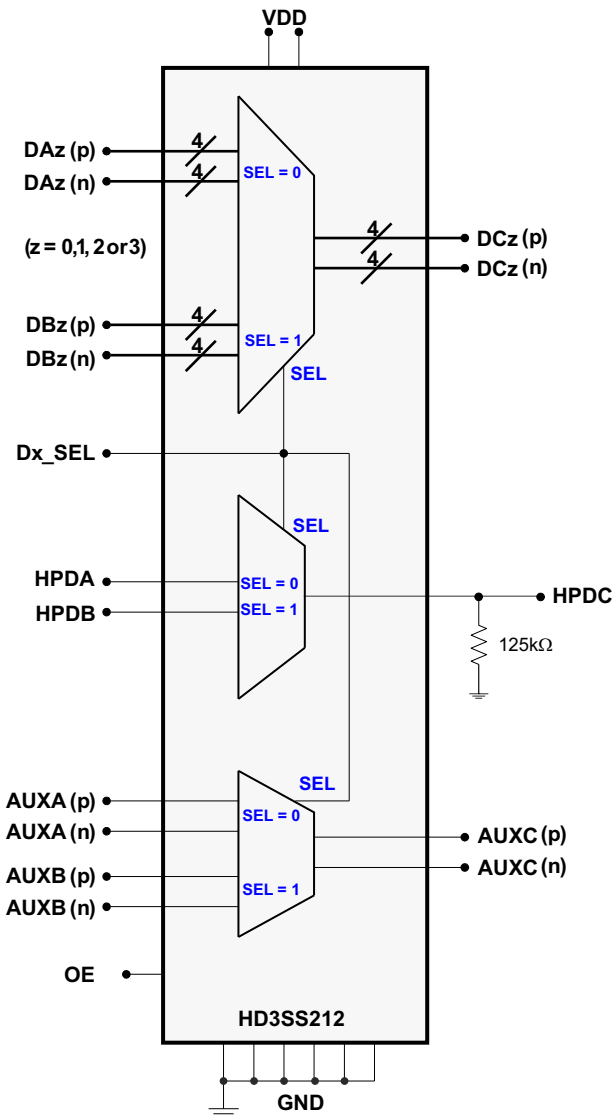

8.3 Feature Description

Refer to [セクション 8.2](#).

The HD3SS212 behaves as a two to one using high bandwidth pass gates. The input port is selected using the Dx_SEL pin according to [表 8-1](#).

表 8-1. Switch Control Logic

CONTROL LINES	SWITCHED I/O PINS ^{(1) (2)}				
	Dx_SEL	DCz(p) PIN z = 0, 1, 2 or 3	DCz(n) PIN z = 0, 1, 2 or 3	HPDC PIN	AUXC(p) PIN
L	DAz(p)	DAz(n)	HPDA	AUXA(p)	AUXA(n)
H	DBz(p)	DBz(n)	HPDB	AUXVB(p)	AUXVB(n)

(1) OE pin - For normal operation, drive OE high. Driving the OE pin low will disable the switch to enable power savings.

(2) The ports which are not selected by the Control Lines will be in High Impedance State.

8.4 Device Functional Modes

The HD3SS212 can be operated in normal operation mode or in shut down mode. In normal operation, the input ports of the HD3SS212 are routed to the output ports according to [表 8-1](#). In shut down mode the HD3SS212 is disabled to enable power savings with a typical current consumption of 5 μ A. The functional mode is selected through the OE input pin with High for normal operation and LOW for shut down.

9 Application and Implementation

注

Information in the following applications sections is not part of the TI component specification, and TI does not warrant its accuracy or completeness. TI's customers are responsible for determining suitability of components for their purposes. Customers should validate and test their design implementation to confirm system functionality.

9.1 Application Information

9.1.1 AC Coupling Caps

Many interfaces require AC coupling between the transmitter and receiver. The 0402 capacitors are the preferred option to provide AC coupling, and the 0603 size capacitors also work. The 0805 size capacitors and C-packs should be avoided. When placing AC coupling capacitors symmetric placement is best. A capacitor value of 0.1 μF is best and the value should be match for the \pm signal pair. The placement should be along the TX pairs on the system board, which are usually routed on the top layer of the board. There are several placement options for the AC coupling capacitors. Because the switch requires a bias voltage, the capacitors must only be placed on one side of the switch. If they are placed on both sides of the switch, a biasing voltage should be provided. A few placement options are shown below. In [Figure 9-1](#), the coupling capacitors are placed between the switch and endpoint. In this situation, the switch is biased by the system/host controller.

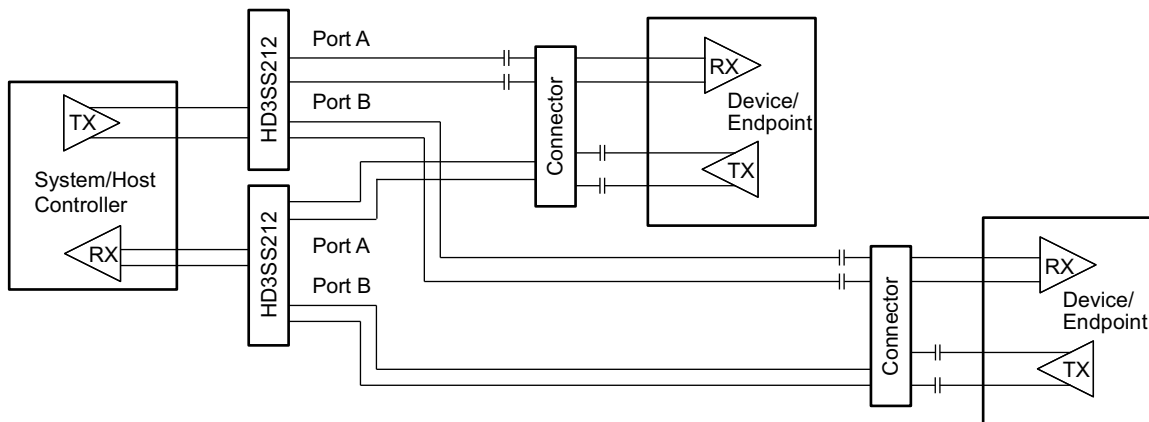

Figure 9-1. AC Coupling Capacitors Between Switch TX and Endpoint TX

In [Figure 9-2](#), the coupling capacitors are placed on the host transmit pair and endpoint transmit pair. In this situation, the switch on the top is biased by the endpoint and the lower switch is biased by the host controller.

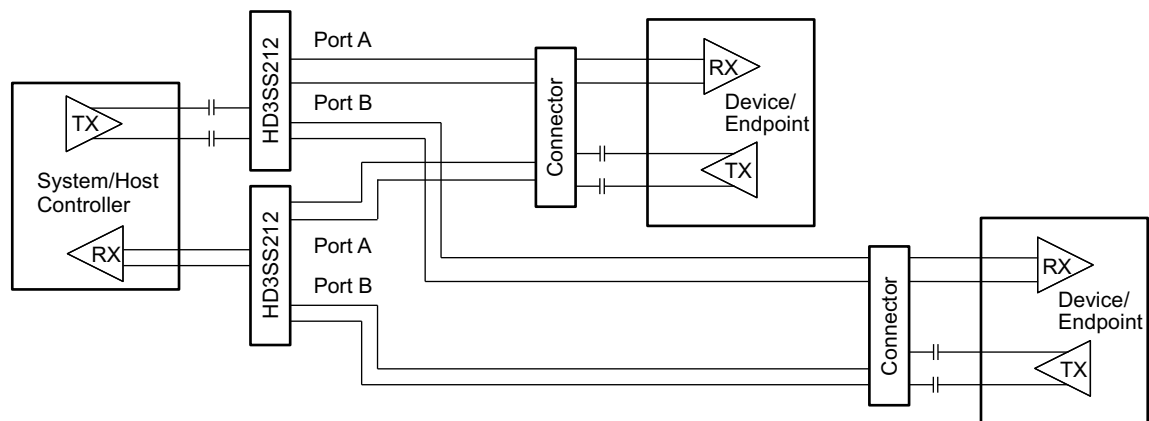
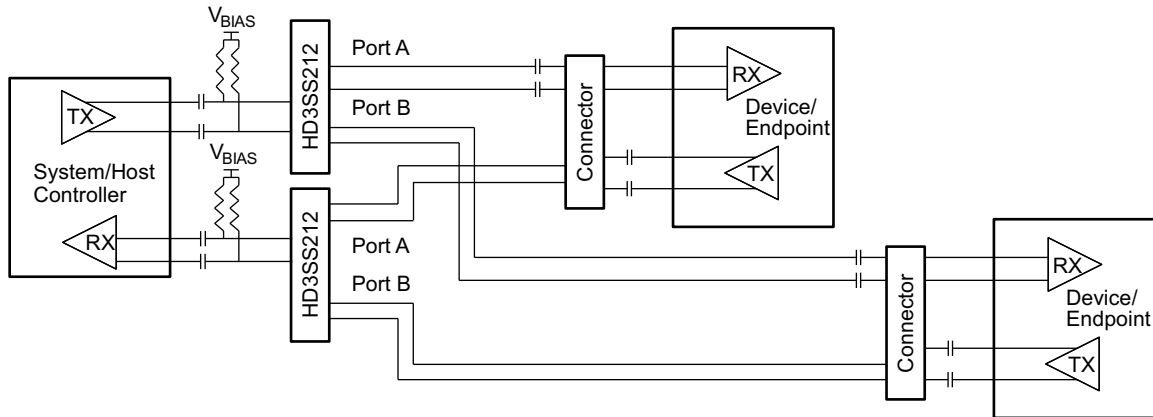

Figure 9-2. AC Coupling Capacitors on Host TX and Endpoint TX

If the common-mode voltage in the system is higher than 2 V, the coupling capacitors are placed on both sides of the switch (shown in 9-3). A biasing voltage of less than 2 V is required in this case.



9-3. AC Coupling Capacitors on Both Sides of Switch

9.2 Typical Application

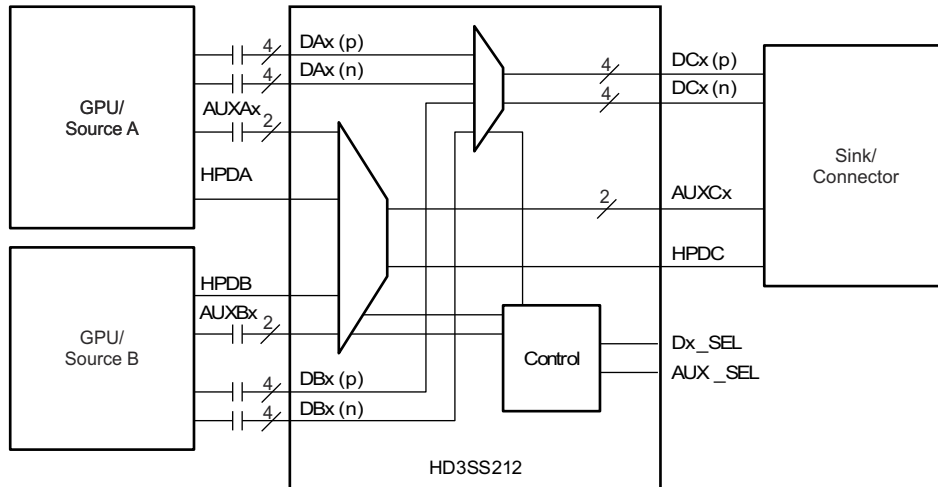

Copyright © 2016, Texas Instruments Incorporated

9-4. Dual Source Connection Block Diagram

9.2.1 Design Requirements

表 9-1 lists the design parameters.

表 9-1. Design Parameters

DESIGN PARAMETERS	EXAMPLE VALUE
Input voltage range	3.3 V
Decoupling capacitors	0.1 μ F
AC capacitors	75 nF – 200 nF (100 nF shown) USBAA TX p and AC capacitors n lines require AC capacitors. Alternate mode signals may or may not require AC capacitors

9.2.2 Detailed Design Procedure

- Connect VDD and GND pins to the power and ground planes of the printed circuit board, with 0.1- μ F bypass capacitor

HD3SS212

JAJSQA0D – DECEMBER 2011 – REVISED DECEMBER 2020

- Use +3.3-V TTL/CMOS logic level at SEL
- Use controlled-impedance transmission media for all the differential signals
- Ensure the received complimentary signals are with a differential amplitude of < 1800 mVpp and a common-mode voltage of < 2V.

9.2.3 Application Curves

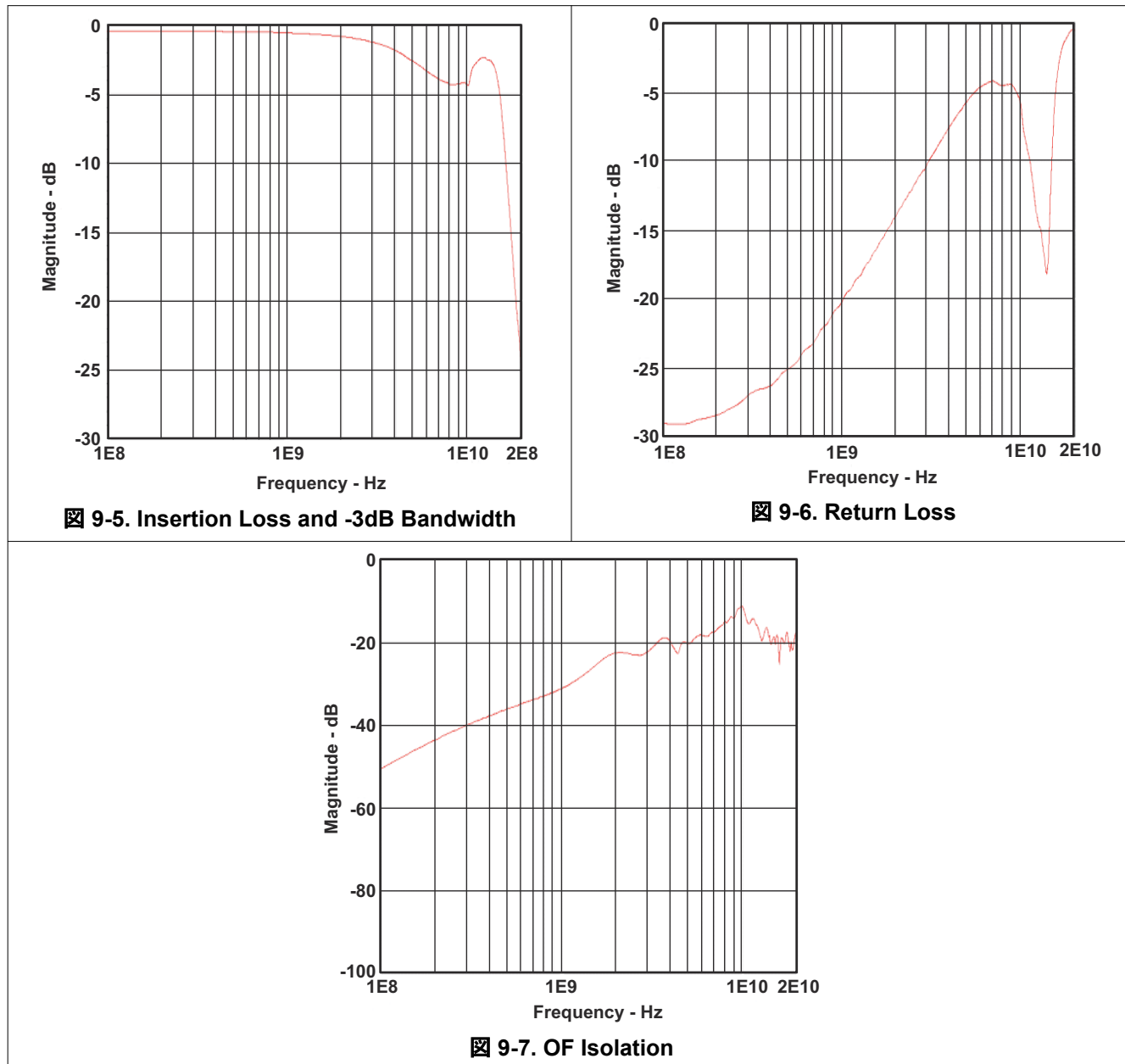

Power Supply Recommendations

The HD3SS212 requires +3.3-V digital power sources. VDD 3.3 supply must have 0.1- μ F bypass capacitors to VSS (ground) in order for proper operation. The recommendation is one capacitor for each power terminal. Place the capacitor as close as possible to the terminal on the device and keep trace length to a minimum. Smaller value capacitors like 0.01- μ F are also recommended on the digital supply terminals.

10 Layout

10.1 Layout Guidelines

- Decoupling caps should be placed next to each power terminal on the HD3SS212. Take care to minimize the stub length of the trace connecting the capacitor to the power pin.
- Avoid sharing vias between multiple decoupling caps
- Place vias as close as possible to the decoupling cap solder pad
- Widen VDD/GND planes to reduce effect of static and dynamic IR drop
- The VBUS traces/planes must be wide enough to carry maximum of 2-A current

10.2 Layout Example

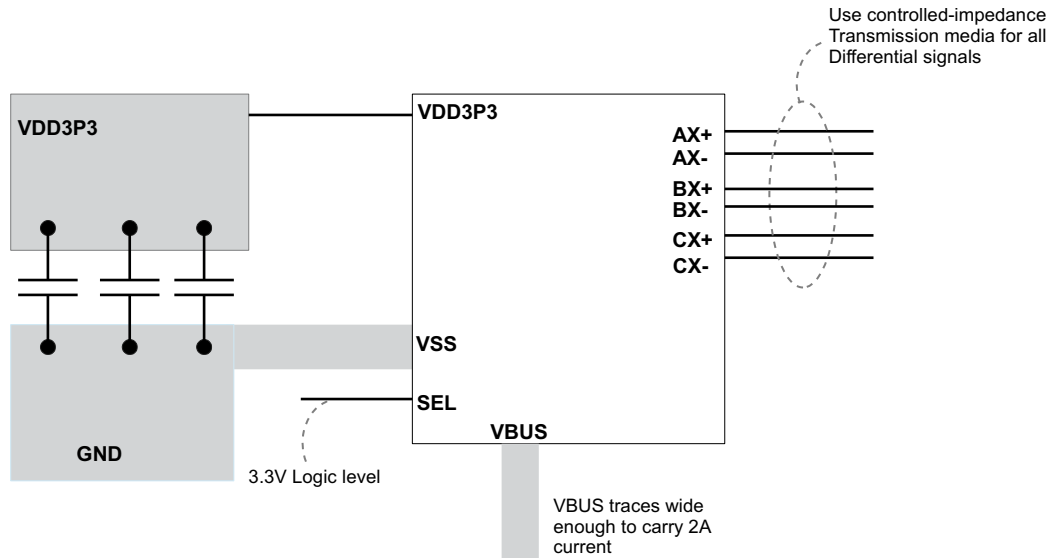

 10-1. Layout Example

11 Device and Documentation Support

11.1 Receiving Notification of Documentation Updates

To receive notification of documentation updates, navigate to the device product folder on ti.com. In the upper right corner, click on *Alert me* to register and receive a weekly digest of any product information that has changed. For change details, review the revision history included in any revised document.

11.2 Community Resource

11.3 Trademarks

すべての商標は、それぞれの所有者に帰属します。

12 Mechanical, Packaging, and Orderable Information

The following pages include mechanical, packaging, and orderable information. This information is the most current data available for the designated devices. This data is subject to change without notice and revision of this document. For browser-based versions of this data sheet, refer to the left-hand navigation.

PACKAGING INFORMATION

Orderable Device	Status (1)	Package Type	Package Drawing	Pins	Package Qty	Eco Plan (2)	Lead finish/ Ball material (6)	MSL Peak Temp (3)	Op Temp (°C)	Device Marking (4/5)	Samples
HD3SS212ZXHR	ACTIVE	NFBGA	ZXH	48	2500	RoHS & Green	SNAGCU	Level-3-260C-168 HR	-40 to 105	HD3SS212	Samples
HD3SS212ZXHT	ACTIVE	NFBGA	ZXH	48	250	RoHS & Green	SNAGCU	Level-3-260C-168 HR	-40 to 105	HD3SS212	Samples

(1) The marketing status values are defined as follows:

ACTIVE: Product device recommended for new designs.

LIFEBUY: TI has announced that the device will be discontinued, and a lifetime-buy period is in effect.

NRND: Not recommended for new designs. Device is in production to support existing customers, but TI does not recommend using this part in a new design.

PREVIEW: Device has been announced but is not in production. Samples may or may not be available.

OBSOLETE: TI has discontinued the production of the device.

(2) **RoHS:** TI defines "RoHS" to mean semiconductor products that are compliant with the current EU RoHS requirements for all 10 RoHS substances, including the requirement that RoHS substance do not exceed 0.1% by weight in homogeneous materials. Where designed to be soldered at high temperatures, "RoHS" products are suitable for use in specified lead-free processes. TI may reference these types of products as "Pb-Free".

RoHS Exempt: TI defines "RoHS Exempt" to mean products that contain lead but are compliant with EU RoHS pursuant to a specific EU RoHS exemption.

Green: TI defines "Green" to mean the content of Chlorine (Cl) and Bromine (Br) based flame retardants meet JS709B low halogen requirements of <=1000ppm threshold. Antimony trioxide based flame retardants must also meet the <=1000ppm threshold requirement.

(3) MSL, Peak Temp. - The Moisture Sensitivity Level rating according to the JEDEC industry standard classifications, and peak solder temperature.

(4) There may be additional marking, which relates to the logo, the lot trace code information, or the environmental category on the device.

(5) Multiple Device Markings will be inside parentheses. Only one Device Marking contained in parentheses and separated by a "~" will appear on a device. If a line is indented then it is a continuation of the previous line and the two combined represent the entire Device Marking for that device.

(6) Lead finish/Ball material - Orderable Devices may have multiple material finish options. Finish options are separated by a vertical ruled line. Lead finish/Ball material values may wrap to two lines if the finish value exceeds the maximum column width.

Important Information and Disclaimer:The information provided on this page represents TI's knowledge and belief as of the date that it is provided. TI bases its knowledge and belief on information provided by third parties, and makes no representation or warranty as to the accuracy of such information. Efforts are underway to better integrate information from third parties. TI has taken and continues to take reasonable steps to provide representative and accurate information but may not have conducted destructive testing or chemical analysis on incoming materials and chemicals. TI and TI suppliers consider certain information to be proprietary, and thus CAS numbers and other limited information may not be available for release.

In no event shall TI's liability arising out of such information exceed the total purchase price of the TI part(s) at issue in this document sold by TI to Customer on an annual basis.

TAPE AND REEL INFORMATION

QUADRANT ASSIGNMENTS FOR PIN 1 ORIENTATION IN TAPE



*All dimensions are nominal

Device	Package Type	Package Drawing	Pins	SPQ	Reel Diameter (mm)	Reel Width W1 (mm)	A0 (mm)	B0 (mm)	K0 (mm)	P1 (mm)	W (mm)	Pin1 Quadrant
HD3SS212ZXHR	NFBGA	ZXH	48	2500	330.0	12.4	5.3	5.3	1.5	8.0	12.0	Q1
HD3SS212ZXHT	NFBGA	ZXH	48	250	330.0	12.4	5.3	5.3	1.5	8.0	12.0	Q1

TAPE AND REEL BOX DIMENSIONS

*All dimensions are nominal

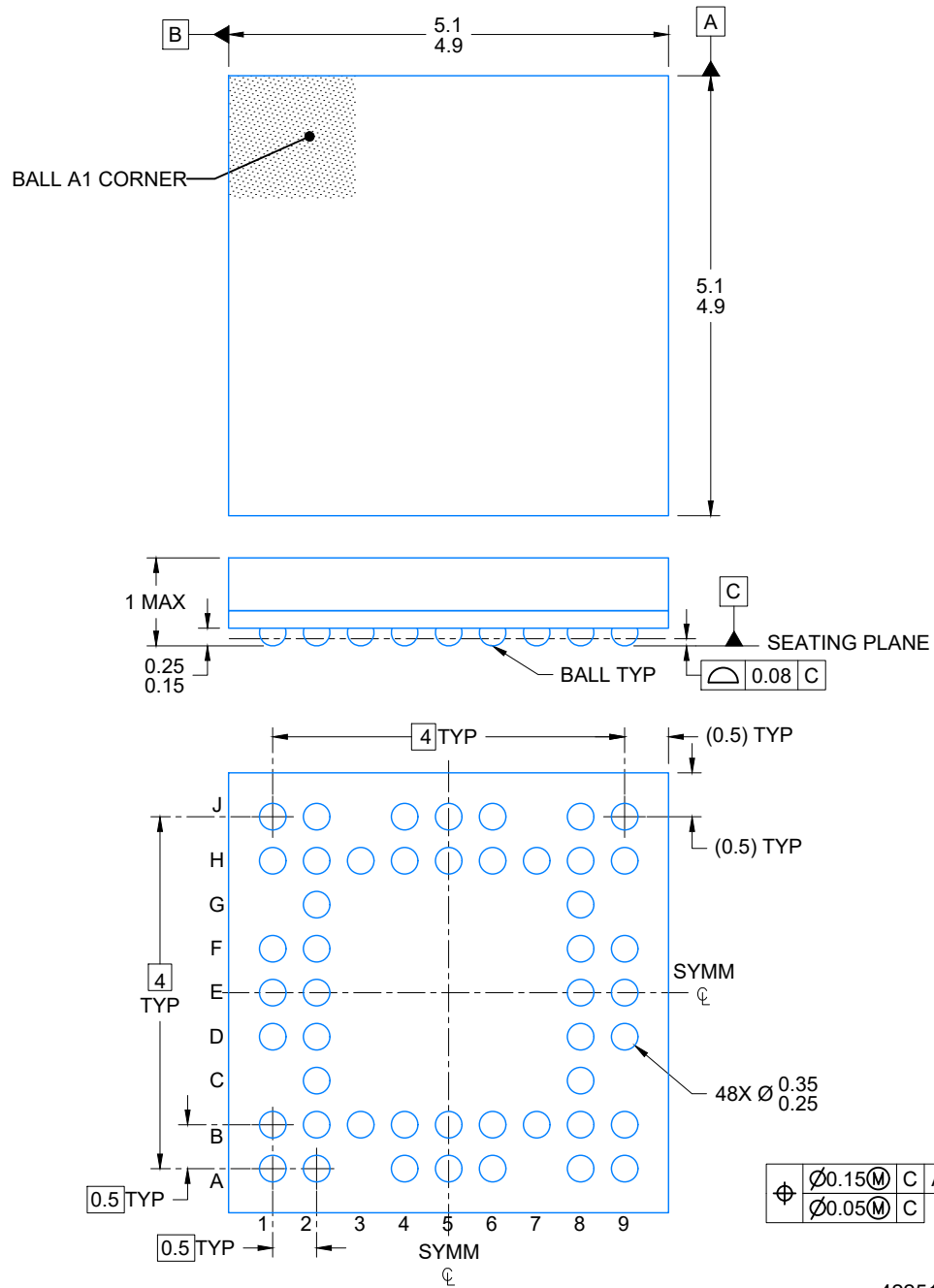
Device	Package Type	Package Drawing	Pins	SPQ	Length (mm)	Width (mm)	Height (mm)
HD3SS212ZXHR	NFBGA	ZXH	48	2500	336.6	336.6	31.8
HD3SS212ZXHT	NFBGA	ZXH	48	250	336.6	336.6	31.8



4225133 /A 08/2019

NOTES:

NanoFree is a trademark of Texas Instruments.

1. All linear dimensions are in millimeters. Any dimensions in parenthesis are for reference only. Dimensioning and tolerancing per ASME Y14.5M.
2. This drawing is subject to change without notice.

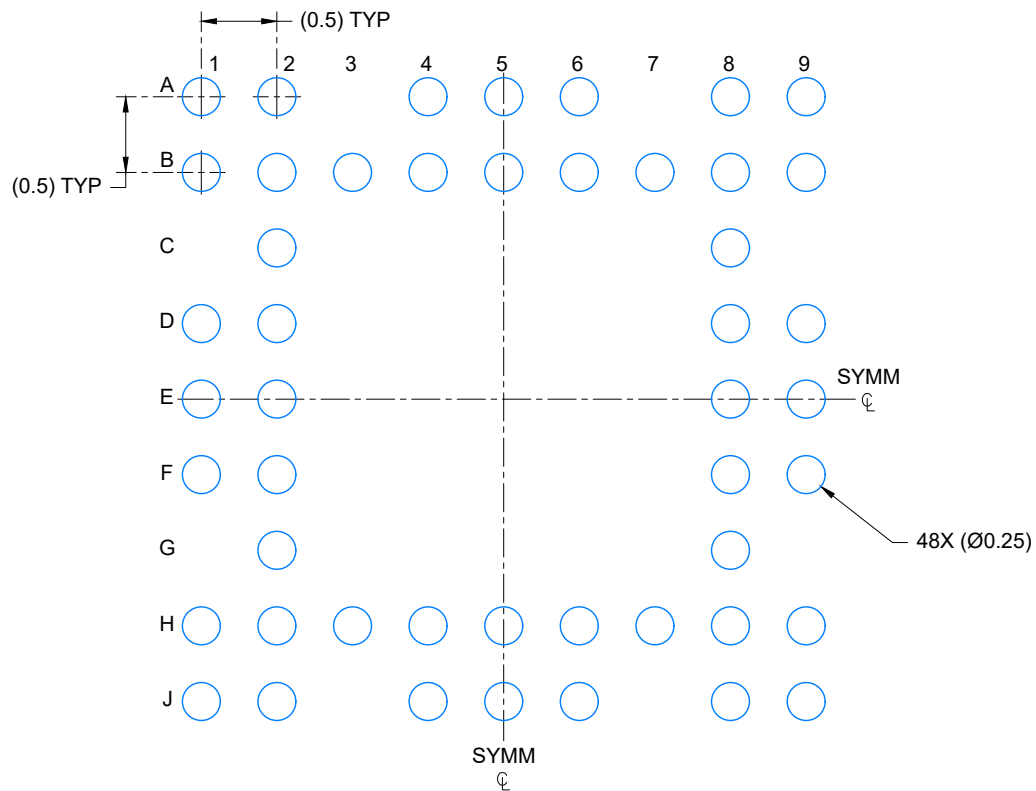

LAND PATTERN EXAMPLE
SCALE: 20X

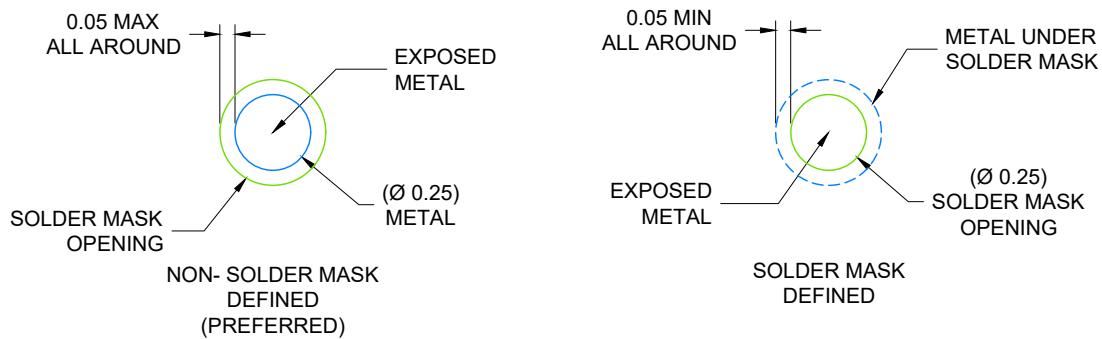

SOLDER MASK DETAILS
NOT TO SCALE

4225133 /A 08/2019

NOTES: (continued)

- Final dimensions may vary due to manufacturing tolerance considerations and also routing constraints. Refer to Texas Instruments Literature number SNVA009 (www.ti.com/lit/snva009).

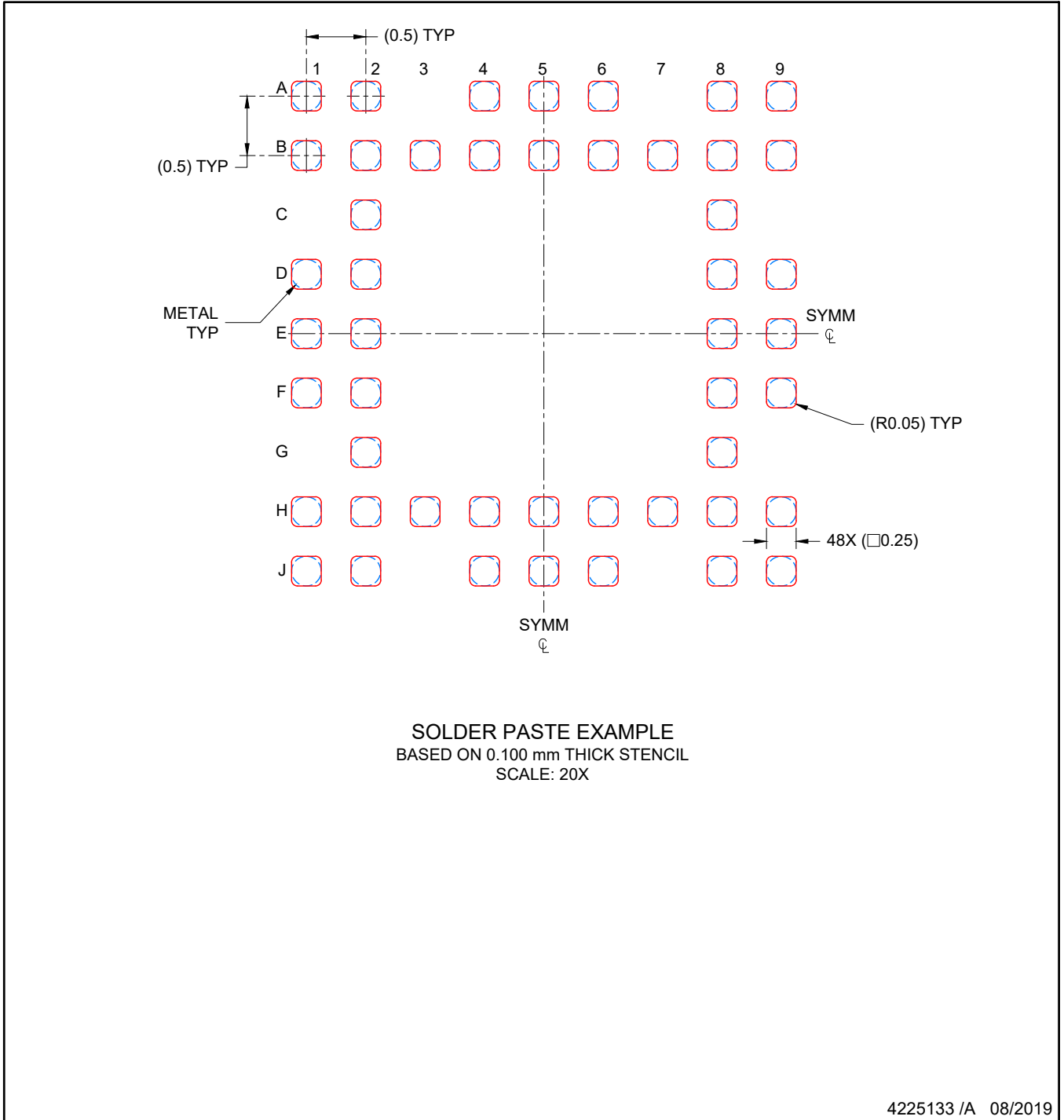

NOTES: (continued)

- 4. Laser cutting apertures with trapezoidal walls and rounded corners may offer better paste release.

重要なお知らせと免責事項

TI は、技術データと信頼性データ (データシートを含みます)、設計リソース (リファレンス・デザインを含みます)、アプリケーションや設計に関する各種アドバイス、Web ツール、安全性情報、その他のリソースを、欠陥が存在する可能性のある「現状のまま」提供しており、商品性および特定目的に対する適合性の黙示保証、第三者の知的財産権の非侵害保証を含むいかなる保証も、明示的または黙示的にかかわらず拒否します。

これらのリソースは、TI 製品を使用する設計の経験を積んだ開発者への提供を意図したものです。(1) お客様のアプリケーションに適した TI 製品の選定、(2) お客様のアプリケーションの設計、検証、試験、(3) お客様のアプリケーションに該当する各種規格や、その他のあらゆる安全性、セキュリティ、規制、または他の要件への確実な適合に関する責任を、お客様のみが単独で負うものとし、

上記の各種リソースは、予告なく変更される可能性があります。これらのリソースは、リソースで説明されている TI 製品を使用するアプリケーションの開発の目的でのみ、TI はその使用をお客様に許諾します。これらのリソースに関して、他の目的で複製することや掲載することは禁止されています。TI や第三者の知的財産権のライセンスが付与されている訳ではありません。お客様は、これらのリソースを自身で使用した結果発生するあらゆる申し立て、損害、費用、損失、責任について、TI およびその代理人を完全に補償するものとし、TI は一切の責任を拒否します。

TI の製品は、[TI の販売条件](#)、または [ti.com](https://www.ti.com) やかかる TI 製品の関連資料などのいずれかを通じて提供する適用可能な条項の下で提供されています。TI がこれらのリソースを提供することは、適用される TI の保証または他の保証の放棄の拡大や変更を意味するものではありません。

お客様がいかなる追加条項または代替条項を提案した場合でも、TI はそれらに異議を唱え、拒否します。

郵送先住所 : Texas Instruments, Post Office Box 655303, Dallas, Texas 75265
Copyright © 2023, Texas Instruments Incorporated