

## HD3SS3412A 4チャンネル高性能差動スイッチ

### 1 特長

- PCI Express Gen3やUSB 3.0などの各種インターフェイス規格に準拠し、最大12Gbpsで動作
- 8GHzを超える広い-3dBの差動帯域幅
- 優れた動特性(4GHz時)
  - クロストーク=-35dB
  - オフ・アイソレーション=-19dB
  - 挿入損失=-1.5dB
  - リターン・ロス=-11dB
- 双方向「マルチプレクサ/デマルチプレクサ」差動スイッチ
- VDD動作範囲: 3.3V±10%
- 小型の3.5mm×9.0mm、42ピンWQFNパッケージ
- 共通の業界標準ピン配置
- XAUIおよびSGMIIをサポート

### 2 アプリケーション

- デスクトップPCおよびノートPC
- サーバーおよびストレージ・エリア・ネットワーク
- PCI Expressバックプレーン
- 共有I/Oポート

### 3 概要

HD3SS3412Aデバイスは、PCまたはサーバーで2つのフルPCI Express x1レーンを使用し、それぞれ1つのソースから2つのターゲット地点のいずれかに接続するようなアプリケーションなど、4つの差動チャンネルのスイッチングに対応した高速パッシブ・スイッチです。双方向型であるため、2つのプラットフォームで共有するペリフェラルなど、1つのターゲット・デバイスと2つのソース・デバイスの間の接続を可能にするアプリケーションもサポートしています。

HD3SS3412Aには1つの制御線(SELピン)があり、これを使用してポートAと、ポートBまたはポートCとの間の信号経路を制御できます。

HD3SS3412Aは、他の複数のベンダと共通の実装サイズを持つ業界標準の42ピンWQFNパッケージで供給されます。このデバイスは、0°C~70°Cの全温度範囲にわたり3.3Vの単一電源で動作する仕様となっています。

#### 製品情報<sup>(1)</sup>

型番	パッケージ	本体サイズ(公称)
HD3SS3412A	WQFN (42)	9.0mm×3.50mm

(1) 利用可能なすべてのパッケージについては、このデータシートの末尾にある注文情報を参照してください。

HD3SS3412Aピン配置

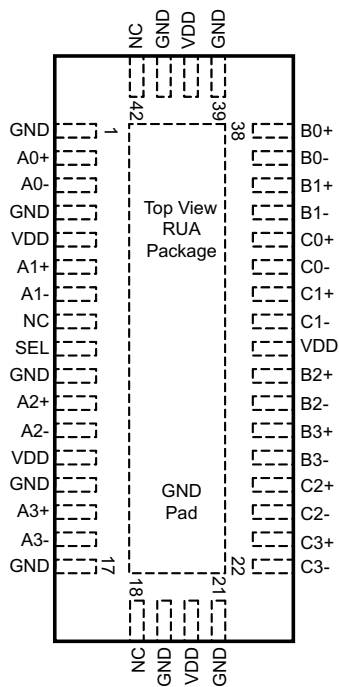

HD3SS3412Aスイッチのフロースルー配線

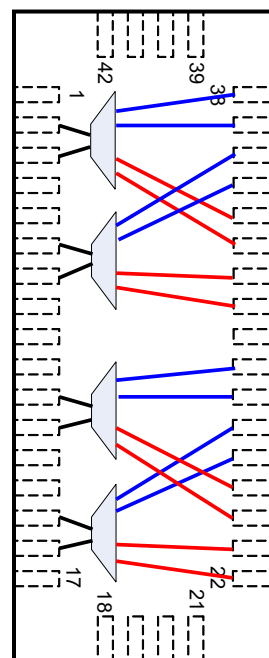

## 目次

<b>1</b>	特長 .....	1	9.2	Functional Block Diagram .....	12
<b>2</b>	アプリケーション .....	1	9.3	Feature Description .....	13
<b>3</b>	概要 .....	1	9.4	Device Functional Modes .....	13
<b>4</b>	改訂履歴 .....	2	<b>10</b>	<b>Application and Implementation</b> .....	14
<b>5</b>	概要 (続き) .....	3	10.1	Application Information .....	14
<b>6</b>	<b>Pin Configuration and Functions</b> .....	3	10.2	Typical Application .....	15
<b>7</b>	<b>Specifications</b> .....	6	<b>11</b>	<b>Power Supply Recommendations</b> .....	17
7.1	Absolute Maximum Ratings .....	6	<b>12</b>	<b>Layout</b> .....	17
7.2	ESD Ratings .....	6	12.1	Layout Guidelines .....	17
7.3	Recommended Operating Conditions .....	6	12.2	Layout Example .....	17
7.4	Thermal Information .....	6	<b>13</b>	<b>デバイスおよびドキュメントのサポート</b> .....	18
7.5	Electrical Characteristics .....	7	13.1	ドキュメントの更新通知を受け取る方法 .....	18
7.6	Dissipation Ratings .....	7	13.2	コミュニティ・リソース .....	18
7.7	Typical Characteristics .....	9	13.3	商標 .....	18
<b>8</b>	<b>Parameter Measurement Information</b> .....	10	13.4	静電気放電に関する注意事項 .....	18
<b>9</b>	<b>Detailed Description</b> .....	12	13.5	Glossary .....	18
9.1	Overview .....	12	<b>14</b>	<b>メカニカル、パッケージ、および注文情報</b> .....	18

## 4 改訂履歴

資料番号末尾の英字は改訂を表しています。その改訂履歴は英語版に準じています。

日付	改訂内容	注
2017年12月	*	初版

## 5 概要 (続き)

HD3SS3412Aは、回路基板における2地点間の高速信号のルーティングに適した汎用4チャンネル高速マルチプレクサ/デマルチプレクサ・スイッチです。PCI Express Gen3アプリケーション専用には設計されていますが、ほかにもUSB 3.0やDisplayPort 1.2など、差動振幅1800mVpp未満、同相電圧2.0V未満のいくつかの高速データ・プロトコルをサポートしています。このデバイスにある1つのセレクト(SEL)入力ピンは、システム内またはマイクロコントローラから利用可能なGPIOピンにより簡単に制御できます。

## 6 Pin Configuration and Functions

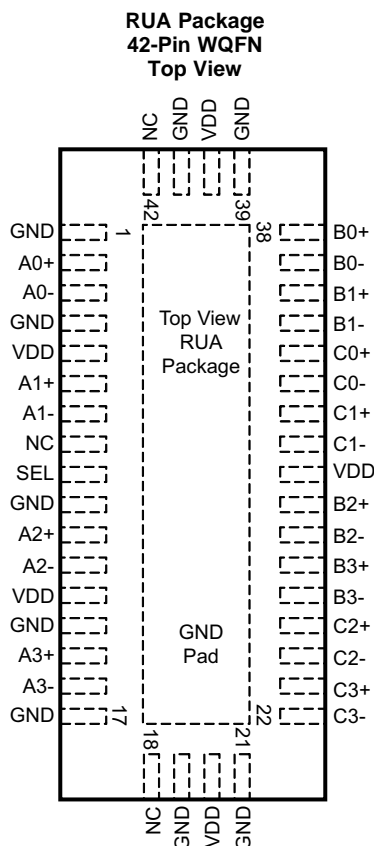

**Pin Functions**

PIN		I/O	DESCRIPTION
NAME	NO.		
<b>SWITCH PORT A</b>			
A0+	2	I/O	Port A, Channel 0, High-Speed Positive Signal
A0-	3	I/O	Port A, Channel 0, High-Speed Negative Signal
A1+	6	I/O	Port A, Channel 1, High-Speed Positive Signal
A1-	7	I/O	Port A, Channel 1, High-Speed Negative Signal
A2+	11	I/O	Port A, Channel 2, High-Speed Positive Signal
A2-	12	I/O	Port A, Channel 2, High-Speed Negative Signal
A3+	15	I/O	Port A, Channel 3, High-Speed Positive Signal
A3-	16	I/O	Port A, Channel 3, High-Speed Negative Signal
<b>SWITCH PORT B</b>			
B0+	38	I/O	Port B, Channel 0, High-Speed Positive Signal
B0-	37	I/O	Port B, Channel 0, High-Speed Negative Signal

**Pin Functions (continued)**

PIN		I/O	DESCRIPTION
NAME	NO.		
B1+	36	I/O	Port B, Channel 1, High-Speed Positive Signal
B1–	35	I/O	Port B, Channel 1, High-Speed Negative Signal
B2+	29	I/O	Port B, Channel 2, High-Speed Positive Signal
B2–	28	I/O	Port B, Channel 2, High-Speed Negative Signal
B3+	27	I/O	Port B, Channel 3, High-Speed Positive Signal
B3–	26	I/O	Port B, Channel 3, High-Speed Negative Signal

**Pin Functions (continued)**

PIN		I/O	DESCRIPTION
NAME	NO.		
<b>SWITCH PORT C</b>			
C0+	34	I/O	Port C, Channel 0, High-Speed Positive Signal
C0–	33	I/O	Port C, Channel 0, High-Speed Negative Signal
C1+	32	I/O	Port C, Channel 1, High-Speed Positive Signal
C1–	31	I/O	Port C, Channel 1, High-Speed Negative Signal
C2+	25	I/O	Port C, Channel 2, High-Speed Positive Signal
C2–	24	I/O	Port C, Channel 2, High-Speed Negative Signal
C3+	23	I/O	Port C, Channel 3, High-Speed Positive Signal
C3–	22	I/O	Port C, Channel 3, High-Speed Negative Signal
<b>CONTROL, SUPPLY, AND NO CONNECT</b>			
NC	8	—	Electrically not connected. May connect to VDD or GND, or leave unconnected.
	18		
	42		
GND	1	Supply	Negative power supply voltage
	4		
	10		
	14		
	17		
	19		
	21		
	39		
	41		
	Center Pad		
SEL	9	I	Select between port B or port C. Internally tied to GND through a 100-kΩ resistor
VDD	5	Supply	Positive power supply voltage
	13		
	20		
	30		
	40		

## 7 Specifications

### 7.1 Absolute Maximum Ratings

Over operating free-air temperature range (unless otherwise noted)<sup>(1)(2)</sup>

		MIN	MAX	UNIT
Supply voltage ( $V_{DD}$ )	Absolute minimum/maximum supply voltage	-0.5	4	V
Voltage	Differential I/O	-0.5	4	V
	Control pin (SEL)	-0.5	$V_{DD} + 0.5$	
Storage temperature, $T_{stg}$		-65	150	°C

- (1) Stresses beyond those listed under *Absolute Maximum Ratings* may cause permanent damage to the device. These are stress ratings only and functional operation of the device at these or any conditions beyond those indicated under *Recommended Operating Conditions* is not implied. Exposure to absolute-maximum-rated conditions for extended periods may affect device reliability.
- (2) All voltage values, except differential voltages, are with respect to network ground terminal.

### 7.2 ESD Ratings

		VALUE	UNIT
$V_{(ESD)}$ Electrostatic discharge	Human-body model (HBM), per ANSI/ESDA/JEDEC JS-001 <sup>(1)</sup>	±4000	V
	Charged-device model (CDM), per JEDEC specification JESD22-C101 <sup>(2)</sup>	±1500	

- (1) JEDEC document JEP155 states that 500-V HBM allows safe manufacturing with a standard ESD control process.
- (2) JEDEC document JEP157 states that 250-V CDM allows safe manufacturing with a standard ESD control process.

### 7.3 Recommended Operating Conditions

Typical values for all parameters are at  $V_{DD} = 3.3$  V and  $T_A = 25^\circ\text{C}$ . (Temperature limits are specified by design)

			MIN	NOM	MAX	UNIT
$V_{DD}$	Supply voltage		3.0	3.3	3.6	V
$V_{IH}$	Input high voltage (SEL pin)		2.0		$V_{DD}$	V
$V_{IL}$	Input low voltage (SEL pin)		-0.1		0.8	V
$V_{I/O\_Diff}$	Differential voltage (differential pins)	Switch I/O diff voltage	0		1.8	V <sub>PP</sub>
$V_{I/O\_CM}$	Common voltage (differential pins)	Switch I/O common-mode voltage	0		2.0	V
$T_A$	Operating free-air temperature	Ambient temperature	0		70	°C

### 7.4 Thermal Information

THERMAL METRIC <sup>(1)</sup>		HD3SS3412A	UNIT
		RUA (WQFN)	
		42 PINS	
$R_{\theta JA}$	Junction-to-ambient thermal resistance	53.8	°C/W
$R_{\theta JC(top)}$	Junction-to-case (top) thermal resistance	38.2	°C/W
$R_{\theta JB}$	Junction-to-board thermal resistance	21.9	°C/W
$\Psi_{JT}$	Junction-to-top characterization parameter	27.4	°C/W
$\Psi_{JB}$	Junction-to-board characterization parameter	5.6	°C/W
$R_{\theta JC(bot)}$	Junction-to-case (bottom) thermal resistance	27.3	°C/W

- (1) For more information about traditional and new thermal metrics, see the [Semiconductor and IC Package Thermal Metrics](#) application report.

## 7.5 Electrical Characteristics

Over operating free-air temperature range (unless otherwise noted)

PARAMETER		TEST CONDITIONS	MIN	TYP	MAX	UNIT
<b>DEVICE PARAMETERS</b>						
$I_{IH}$	Input High Voltage (SEL)	$V_{DD} = 3.6\text{ V}; V_{IN} = V_{DD}$			95	$\mu\text{A}$
$I_{IL}$	Input Low Voltage (SEL)	$V_{DD} = 3.6\text{ V}; V_{IN} = \text{GND}$			1	$\mu\text{A}$
$I_{LK}$	Leakage Current (Differential I/O pins)	$V_{DD} = 3.6\text{ V}; V_{IN} = 0\text{ V}; V_{OUT} = 2\text{ V}$ ( $I_{LK}$ On OPEN outputs) [Ports B and C]			130	$\mu\text{A}$
		$V_{DD} = 3.6\text{ V}; V_{IN} = 2\text{ V}; V_{OUT} = 0\text{ V}$ ( $I_{LK}$ On OPEN outputs) [Port A]			4	
$I_{DD}$	Supply Current	$V_{DD} = 3.6\text{ V}; \text{SEL} = V_{DD}/\text{GND}; \text{Outputs Floating}$		4.7	6	mA
$C_{ON}$	Outputs ON Capacitance	$V_{IN} = 0\text{ V}; \text{Outputs Open}; \text{Switch ON}$		1.5		pF
$C_{OFF}$	Outputs OFF Capacitance	$V_{IN} = 0\text{ V}; \text{Outputs Open}, \text{Switch OFF}$		1		pF
$R_{ON}$	Output ON resistance	$V_{DD} = 3.3\text{ V}; V_{CM} = 0.5\text{ V to } 1.5\text{ V}; I_O = -8\text{ mA}$		5	8	$\Omega$
$\Delta R_{ON}$	ON-resistance match between channels	$V_{DD} = 3.3\text{ V}; -0.35\text{ V} \leq V_{IN} \leq 1.2\text{ V}; I_O = -8\text{ mA}$			2	$\Omega$
	ON-resistance match between pairs of the same channel	$V_{DD} = 3.3\text{ V}; -0.35\text{ V} \leq V_{IN} \leq 1.2\text{ V}; I_O = -8\text{ mA}$			0.7	$\Omega$
$R_{FLAT\_ON}$	ON-resistance flatness ( $R_{ON(MAX)} - R_{ON(MAIN)}$ )	$V_{DD} = 3.3\text{ V}; -0.35\text{ V} \leq V_{IN} \leq 1.2\text{ V}$			1.15	$\Omega$
$t_{PD}$	Switch propagation delay	$R_{sc}$ and $R_{LOAD} = 50\ \Omega$			85	ps
	SEL-to-switch $T_{ON}$	$R_{sc}$ and $R_{LOAD} = 50\ \Omega$		70	250	ns
	SEL-to-switch $T_{OFF}$			70	250	
$T_{SKEW\_Inter}$	Inter-pair output skew (CH-CH)	$R_{sc}$ and $R_{LOAD} = 50\ \Omega$			20	ps
$T_{SKEW\_Intra}$	Intra-pair output skew (bit-bit)	$R_{sc}$ and $R_{LOAD} = 50\ \Omega$			8	ps
$R_L$	Differential return loss ( $V_{CM} = 0\text{ V}$ ) Also see <a href="#">Typical Characteristics</a>	$f = 0.3\text{ MHz}$		-28		dB
		$f = 2500\text{ MHz}$		-12		
		$f = 4000\text{ MHz}$		-11		
$X_{TALK}$	Differential Crosstalk ( $V_{CM} = 0\text{ V}$ ) Also see <a href="#">Typical Characteristics</a>	$f = 0.3\text{ MHz}$		-90		dB
		$f = 2500\text{ MHz}$		-39		
		$f = 4000\text{ MHz}$		-35		
$O_{IRR}$	Differential Off-Isolation ( $V_{CM} = 0\text{ V}$ ) Also see <a href="#">Typical Characteristics</a>	$f = 0.3\text{ MHz}$		-75		dB
		$f = 2500\text{ MHz}$		-22		
		$f = 4000\text{ MHz}$		-19		
$I_L$	Differential Insertion Loss ( $V_{CM} = 0\text{ V}$ ) Also see <a href="#">Typical Characteristics</a>	$f = 0.3\text{ MHz}$		-0.5		dB
		$f = 2500\text{ MHz}$		-1.1		
		$f = 4000\text{ MHz}$		-1.5		
BW	Bandwidth	At -3 dB		8		GHz

## 7.6 Dissipation Ratings

		MIN	MAX	UNIT
$P_D$	Power Dissipation	15.5	21.6	mW

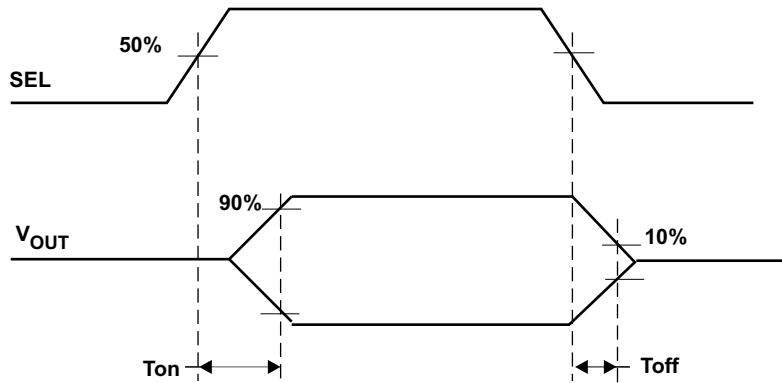
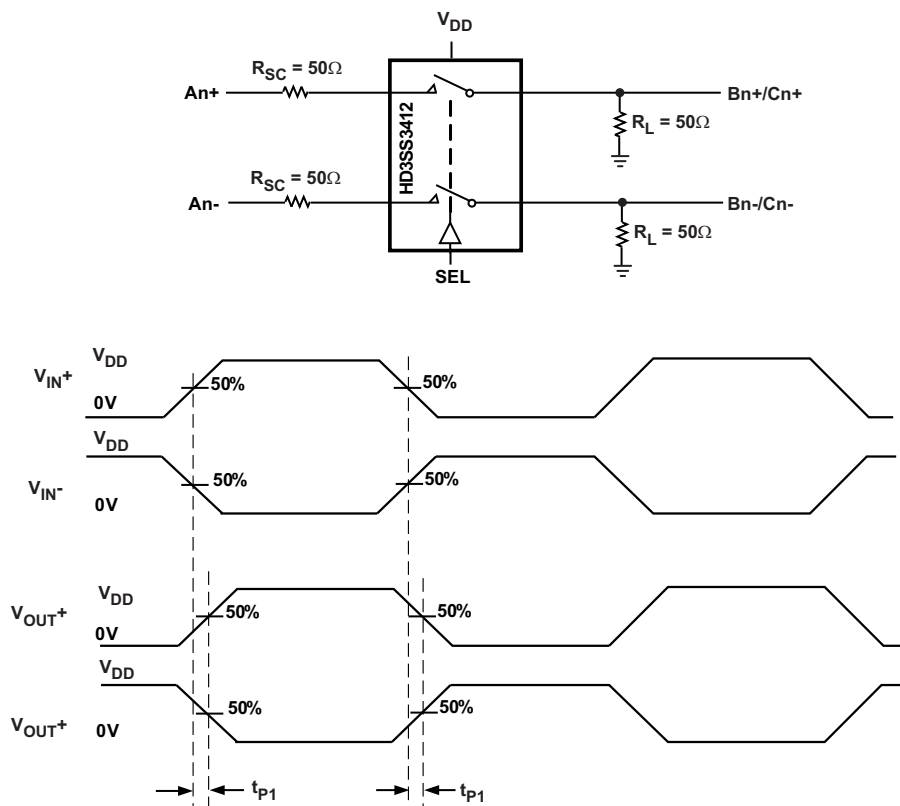

Figure 1. Switch ON and OFF Timing Diagram



$T_{SKEWInter}$  = Difference between  $t_{PD}$  for any two pairs of outputs

$T_{SKEWIntra}$  = Difference between  $t_{p1}$  and  $t_{p2}$  of same pair

Figure 2. Propagation Delay Timing Diagram and Test Setup



## 7.7 Typical Characteristics

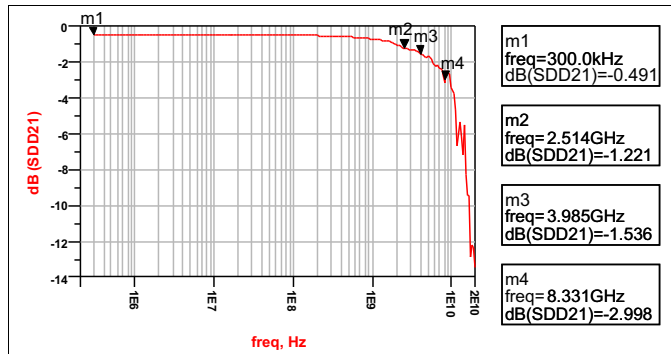

Figure 3. Differential Insertion Loss

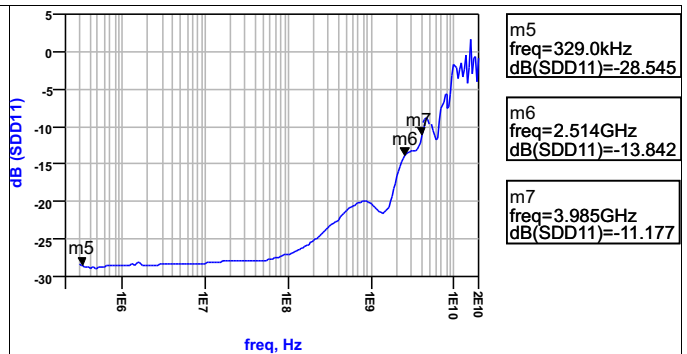

Figure 4. Differential Return Loss

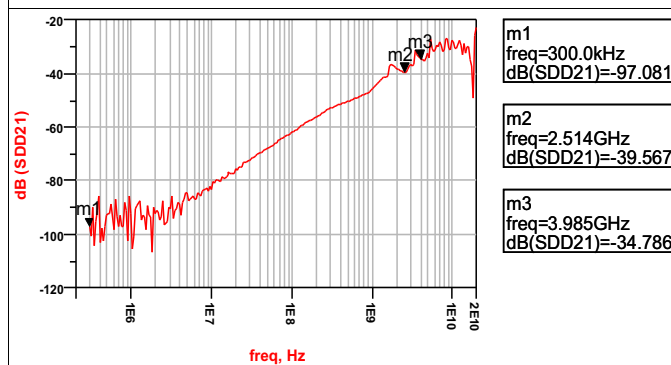

Figure 5. Differential Crosstalk

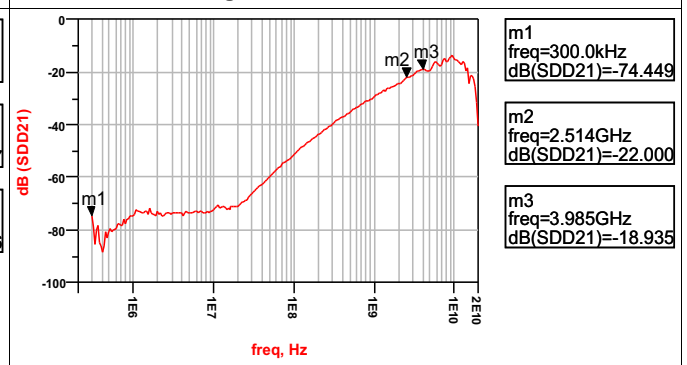

Figure 6. Differential Off Isolation

## 8 Parameter Measurement Information

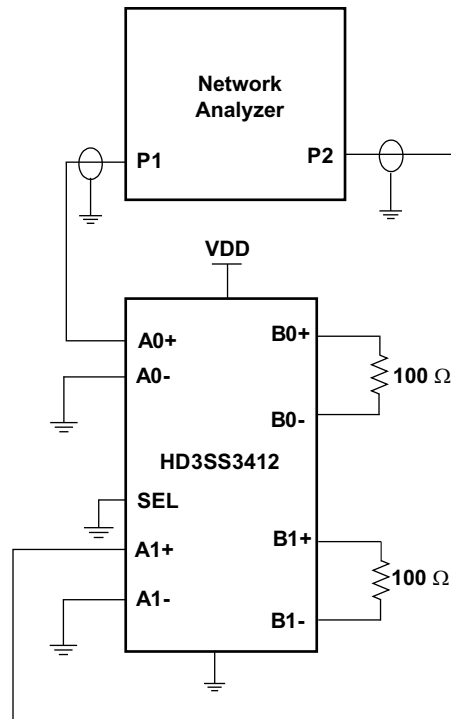

Figure 7. Cross Talk Measurement Setup

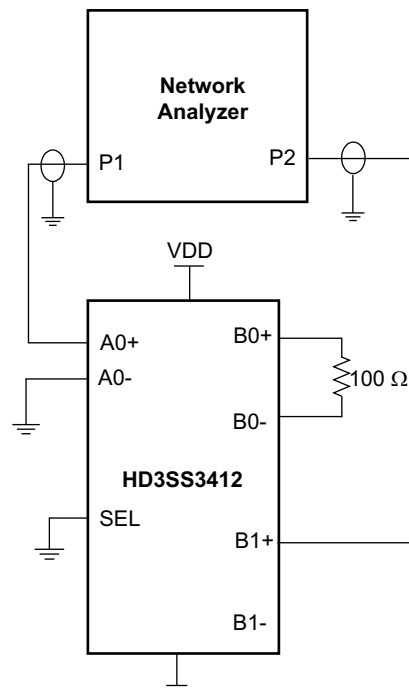

Figure 8. Off Isolation Measurement Setup

Parameter Measurement Information (continued)

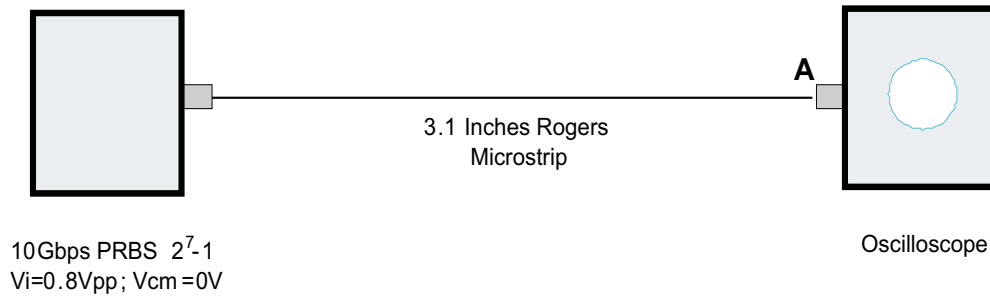

Figure 9. Source Eye Diagram Test Setup

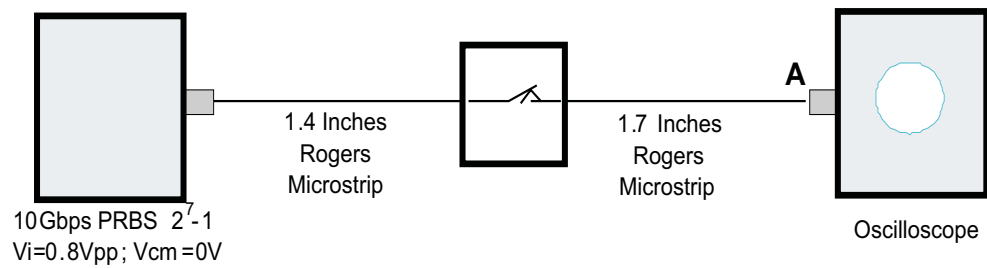

Figure 10. Output Eye Diagram Test Setup

## 9 Detailed Description

### 9.1 Overview

The HD3SS3412A is a high-speed passive switch offered in an industry standard 42-pin WQFN package available in a common footprint shared by several other vendors. The device is specified to operate from a single supply voltage of 3.3 V over the commercial temperature range of 0°C to 70°C. The HD3SS3412A is a generic 4-CH high-speed mux/demux type of switch that can be used for routing high-speed signals between two different locations on a circuit board. Although it was designed specifically to address PCI Express Gen III applications, the HD3SS3412A will also support several other high-speed data protocols with a differential amplitude of < 1800 mVpp and a common-mode voltage of < 2.0 V, as with USB 3.0 and DisplayPort 1.2. The device's one select input (SEL) pin can easily be controlled by an available GPIO pin within a system or from a microcontroller.

### 9.2 Functional Block Diagram

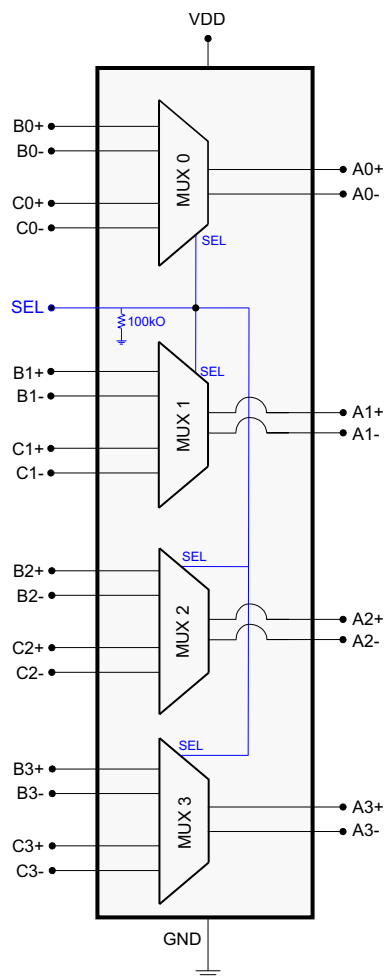

### 9.3 Feature Description

The HD3SS3412A has a single control line (SEL Pin) which can be used to control the signal path between Port A and either Port B or Port C. The one select input (SEL) pin of the device can easily be controlled by an available GPIO pin within a system or from a microcontroller. The input signal is selected using the SEL pin.

**Table 1. Mux Pin Connections<sup>(1)</sup>**

PORT A CHANNEL	PORT B OR PORT C CHANNEL CONNECTED TO PORT A CHANNEL	
	SEL = L	SEL = H
A0+	B0+	C0+
A0–	B0–	C0–
A1+	B1+	C1+
A1–	B1–	C1–
A2+	B2+	C2+
A2–	B2–	C2–
A3+	B3+	C3+
A3–	B3–	C3–

(1) The HD3SS3412A can tolerate polarity inversions for all differential signals on Ports A, B, and C. Take care to ensure the same polarity is maintained on Port A versus Port B/C.

### 9.4 Device Functional Modes

Table 2 lists the functional modes for the HD3SS3412A.

**Table 2. HD3SS3412A Control Logic**

CONTROL PIN (SEL)	PORT A TO PORT B CONNECTION STATUS	PORT A TO PORT C CONNECTION STATUS
L (Default State)	Connected	Disconnected
H	Disconnected	Connected

## 10 Application and Implementation

### NOTE

Information in the following applications sections is not part of the TI component specification, and TI does not warrant its accuracy or completeness. TI's customers are responsible for determining suitability of components for their purposes. Customers should validate and test their design implementation to confirm system functionality.

### 10.1 Application Information

#### 10.1.1 AC Coupling Caps

Many interfaces require AC coupling between the transmitter and receiver. The 0402 capacitors are the preferred option to provide AC coupling, and the 0603 size capacitors also work. The 0805 size capacitors and C-packs should be avoided. When placing AC coupling capacitors symmetric placement is best. A capacitor value of 0.1  $\mu\text{F}$  is best and the value should be match for the  $\pm$  signal pair. The placement should be along the TX pairs on the system board, which are usually routed on the top layer of the board.

There are several placement options for the AC coupling capacitors. Because the switch requires a bias voltage, the capacitors must only be placed on one side of the switch. If they are placed on both sides of the switch, a biasing voltage should be provided. A few placement options are shown below. In [Figure 11](#), the coupling capacitors are placed between the switch and endpoint. In this situation, the switch is biased by the system/host controller.

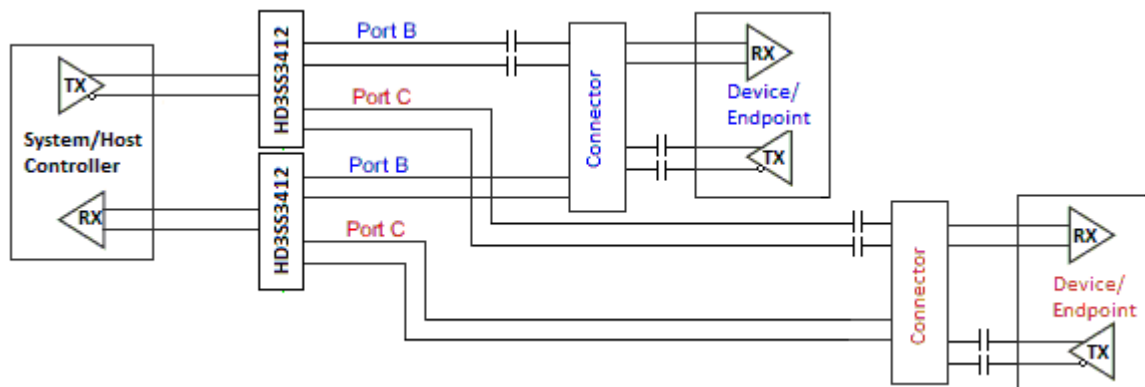

**Figure 11. AC Coupling Capacitors Between Switch Tx and Endpoint Tx**

In [Figure 12](#), the coupling capacitors are placed on the host transmit pair and endpoint transmit pair. In this situation, the switch on the top is biased by the endpoint and the lower switch is biased by the host controller.

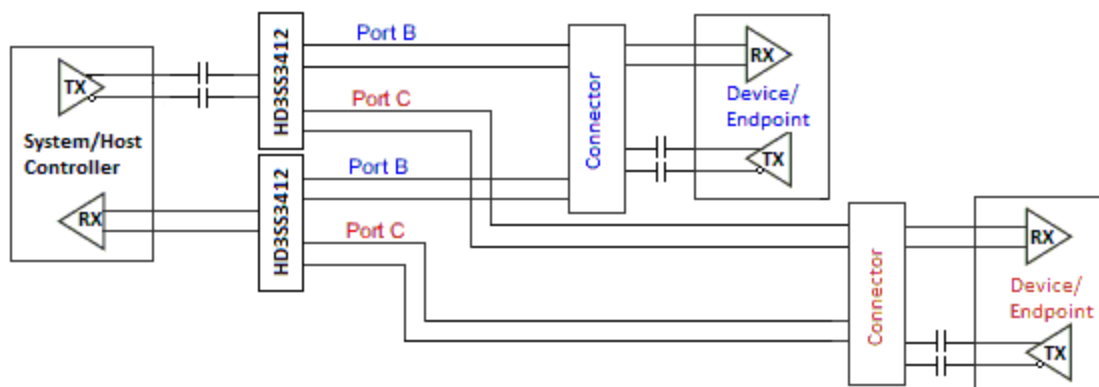

**Figure 12. AC Coupling Capacitors on Host Tx and Endpoint Tx**

### Application Information (continued)

If the common-mode voltage in the system is higher than 2 V, the coupling capacitors are placed on both sides of the switch (shown in Figure 13). A biasing voltage of less than 2 V is required in this case.

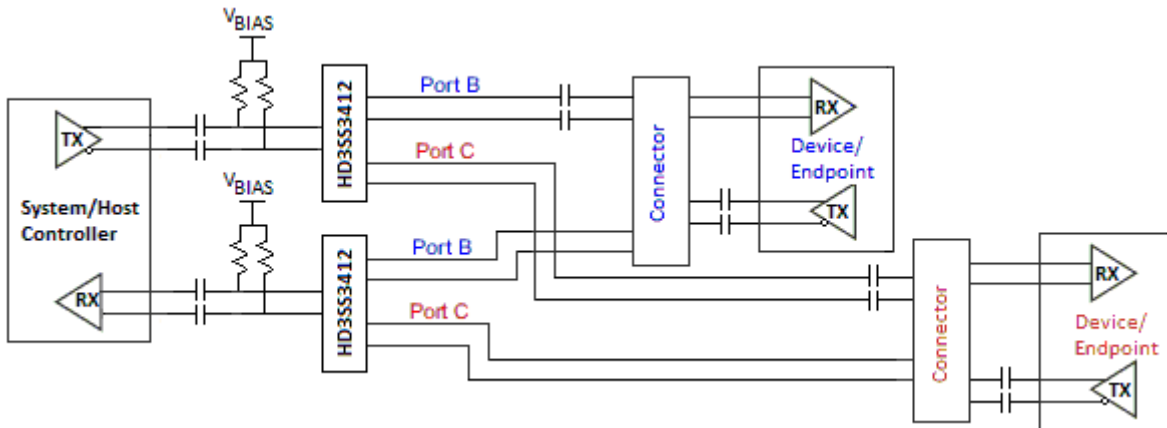

Figure 13. AC Coupling Capacitors on Both Sides of Switch

## 10.2 Typical Application

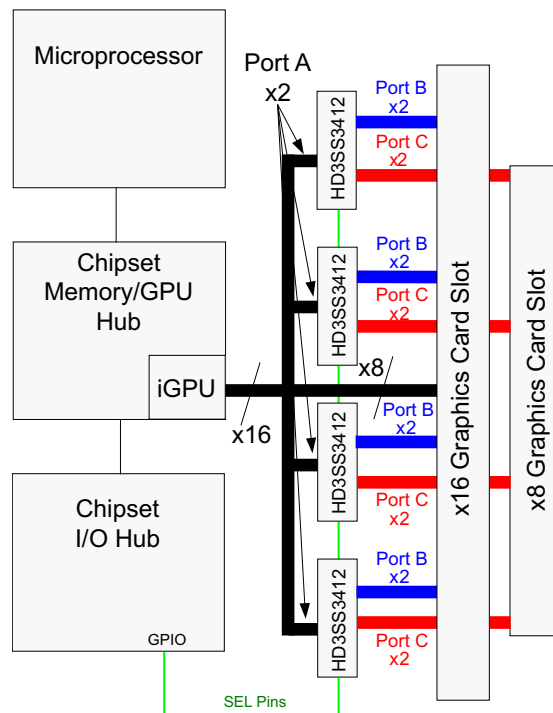

Figure 14. Typical Application Block Diagram

## Typical Application (continued)

### 10.2.1 Design Requirements

Table 3 lists the design parameters of this example.

**Table 3. Design Parameters**

DESIGN PARAMETERS	EXAMPLE VALUE
Input voltage range	3.3 V
Decoupling capacitors	0.1 $\mu$ F
AC capacitors	75 nF – 200 nF (100 nF shown) USBAA TX p and n lines require AC capacitors. Alternate mode signals may or may not require AC capacitors

### 10.2.2 Detailed Design Procedure

- Connect VDD and GND pins to the power and ground planes of the printed circuit board, with 0.1-uF bypass capacitor
- Use +3.3-V TTL/CMOS logic level at SEL
- Use controlled-impedance transmission media for all the differential signals
- Ensure the received complimentary signals are with a differential amplitude of <1800 mVpp and a common-mode voltage of <2 V

### 10.2.3 Application Curves

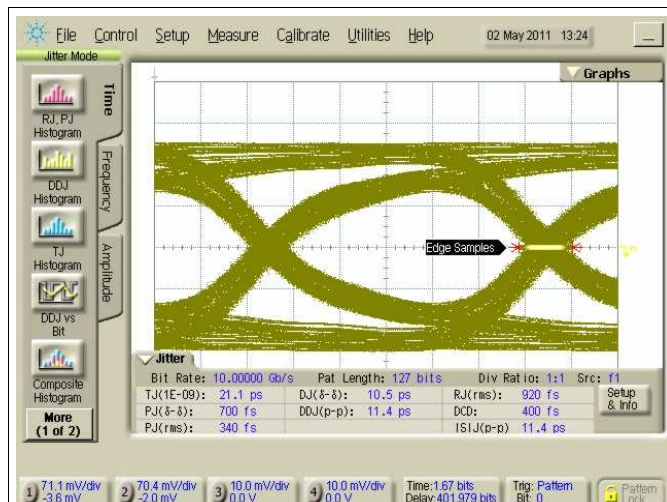

**Figure 15. 10-gbps Source Eye Diagram at a:  $V_{ID} = 800$  Mvpp;  $2^7-1$  Prbs;  $V_{CM} = 0$  V**

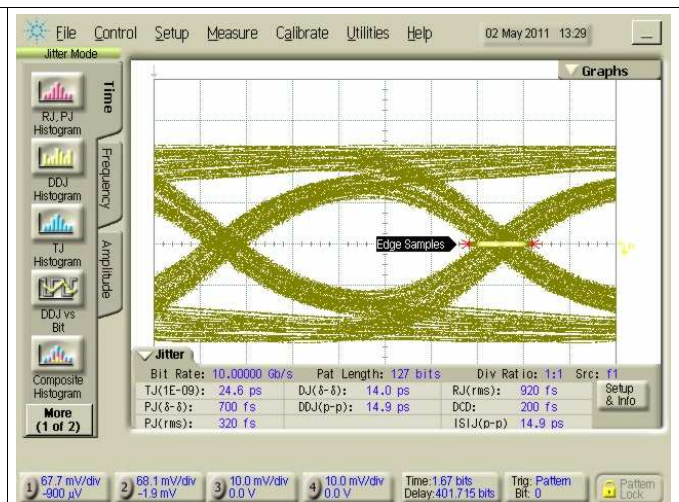

**Figure 16. 10-gbps Output Eye Diagram at a:  $V_{ID} = 800$  Mvpp;  $2^7-1$  Prbs;  $V_{CM} = 0$  v;  $V_{DD} = 3.3$  V; Sel= 0 V**



## 11 Power Supply Recommendations

The HD3SS3412A requires +3.3-V digital power sources. VDD 3.3 supply must have 0.1- $\mu$ F bypass capacitors to VSS (ground) in order for proper operation. The recommendation is one capacitor for each power terminal. Place the capacitor as close as possible to the terminal on the device and keep trace length to a minimum. Smaller value capacitors like 0.01- $\mu$ F are also recommended on the digital supply terminals.

## 12 Layout

### 12.1 Layout Guidelines

- Decoupling caps should be placed next to each power terminal on the HD3SS3412A. Take care to minimize the stub length of the trace connecting the capacitor to the power pin.
- Avoid sharing vias between multiple decoupling caps
- Place vias as close as possible to the decoupling cap solder pad
- Widen VDD/GND planes to reduce effect of static and dynamic IR drop
- The VBUS traces/planes must be wide enough to carry maximum of 2-A current

### 12.2 Layout Example

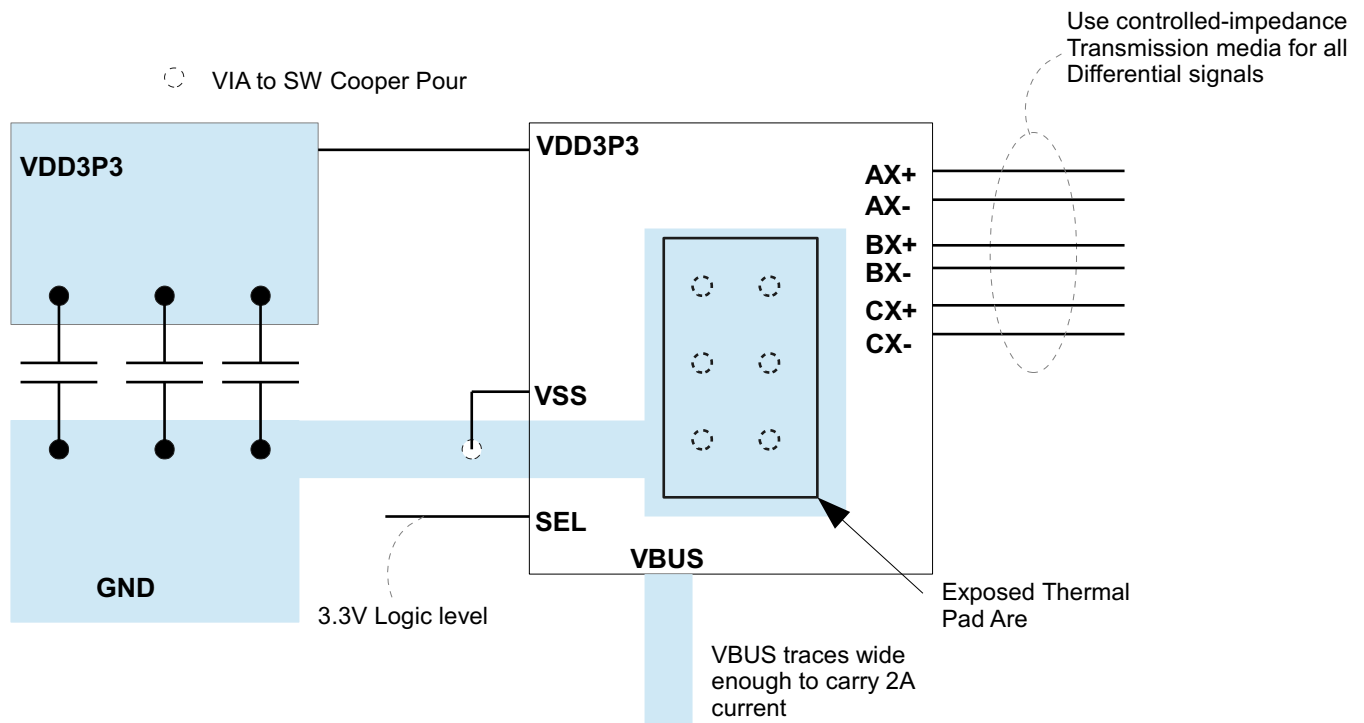

Figure 17. Layout Example

## 13 デバイスおよびドキュメントのサポート

### 13.1 ドキュメントの更新通知を受け取る方法

ドキュメントの更新についての通知を受け取るには、[ti.com](http://ti.com)のデバイス製品フォルダを開いてください。右上の隅にある「通知を受け取る」をクリックして登録すると、変更されたすべての製品情報に関するダイジェストを毎週受け取れます。変更の詳細については、修正されたドキュメントに含まれている改訂履歴をご覧ください。

### 13.2 コミュニティ・リソース

The following links connect to TI community resources. Linked contents are provided "AS IS" by the respective contributors. They do not constitute TI specifications and do not necessarily reflect TI's views; see TI's [Terms of Use](#).

**TI E2E™オンライン・コミュニティ** *TIのE2E (Engineer-to-Engineer) コミュニティ*。エンジニア間の共同作業を促進するために開設されたものです。e2e.ti.comでは、他のエンジニアに質問し、知識を共有し、アイデアを検討して、問題解決に役立てることができます。

**設計サポート** *TIの設計サポート* 役に立つE2Eフォーラムや、設計サポート・ツールをすばやく見つけることができます。技術サポート用の連絡先情報も参照できます。

### 13.3 商標

E2E is a trademark of Texas Instruments.  
All other trademarks are the property of their respective owners.

### 13.4 静電気放電に関する注意事項



すべての集積回路は、適切なESD保護方法を用いて、取扱いと保存を行うようにして下さい。

静電気放電はわずかな性能の低下から完全なデバイスの故障に至るまで、様々な損傷を与えます。高精度の集積回路は、損傷に対して敏感であり、極めてわずかなパラメータの変化により、デバイスに規定された仕様に適合しなくなる場合があります。

### 13.5 Glossary

**SLYZ022** — *TI Glossary*.

This glossary lists and explains terms, acronyms, and definitions.

## 14 メカニカル、パッケージ、および注文情報

以降のページには、メカニカル、パッケージ、および注文に関する情報が記載されています。この情報は、そのデバイスについて利用可能な最新のデータです。このデータは予告なく変更されることがあり、ドキュメントが改訂される場合もあります。本データシートのブラウザ版を使用されている場合は、画面左側の説明をご覧ください。

**PACKAGING INFORMATION**

Orderable Device	Status (1)	Package Type	Package Drawing	Pins	Package Qty	Eco Plan (2)	Lead finish/ Ball material (6)	MSL Peak Temp (3)	Op Temp (°C)	Device Marking (4/5)	Samples
HD3SS3412ARUAR	ACTIVE	WQFN	RUA	42	3000	RoHS & Green	NIPDAU	Level-2-260C-1 YEAR	0 to 70	HD3SS3412	<a href="#">Samples</a>
HD3SS3412ARUAT	ACTIVE	WQFN	RUA	42	250	RoHS & Green	NIPDAU	Level-2-260C-1 YEAR	0 to 70	HD3SS3412	<a href="#">Samples</a>

(1) The marketing status values are defined as follows:

**ACTIVE:** Product device recommended for new designs.

**LIFEBUY:** TI has announced that the device will be discontinued, and a lifetime-buy period is in effect.

**NRND:** Not recommended for new designs. Device is in production to support existing customers, but TI does not recommend using this part in a new design.

**PREVIEW:** Device has been announced but is not in production. Samples may or may not be available.

**OBSOLETE:** TI has discontinued the production of the device.

(2) **RoHS:** TI defines "RoHS" to mean semiconductor products that are compliant with the current EU RoHS requirements for all 10 RoHS substances, including the requirement that RoHS substance do not exceed 0.1% by weight in homogeneous materials. Where designed to be soldered at high temperatures, "RoHS" products are suitable for use in specified lead-free processes. TI may reference these types of products as "Pb-Free".

**RoHS Exempt:** TI defines "RoHS Exempt" to mean products that contain lead but are compliant with EU RoHS pursuant to a specific EU RoHS exemption.

**Green:** TI defines "Green" to mean the content of Chlorine (Cl) and Bromine (Br) based flame retardants meet JS709B low halogen requirements of <=1000ppm threshold. Antimony trioxide based flame retardants must also meet the <=1000ppm threshold requirement.

(3) MSL, Peak Temp. - The Moisture Sensitivity Level rating according to the JEDEC industry standard classifications, and peak solder temperature.

(4) There may be additional marking, which relates to the logo, the lot trace code information, or the environmental category on the device.

(5) Multiple Device Markings will be inside parentheses. Only one Device Marking contained in parentheses and separated by a "~" will appear on a device. If a line is indented then it is a continuation of the previous line and the two combined represent the entire Device Marking for that device.

(6) Lead finish/Ball material - Orderable Devices may have multiple material finish options. Finish options are separated by a vertical ruled line. Lead finish/Ball material values may wrap to two lines if the finish value exceeds the maximum column width.

**Important Information and Disclaimer:**The information provided on this page represents TI's knowledge and belief as of the date that it is provided. TI bases its knowledge and belief on information provided by third parties, and makes no representation or warranty as to the accuracy of such information. Efforts are underway to better integrate information from third parties. TI has taken and continues to take reasonable steps to provide representative and accurate information but may not have conducted destructive testing or chemical analysis on incoming materials and chemicals. TI and TI suppliers consider certain information to be proprietary, and thus CAS numbers and other limited information may not be available for release.

In no event shall TI's liability arising out of such information exceed the total purchase price of the TI part(s) at issue in this document sold by TI to Customer on an annual basis.



**TAPE AND REEL INFORMATION**

**QUADRANT ASSIGNMENTS FOR PIN 1 ORIENTATION IN TAPE**

\*All dimensions are nominal

Device	Package Type	Package Drawing	Pins	SPQ	Reel Diameter (mm)	Reel Width W1 (mm)	A0 (mm)	B0 (mm)	K0 (mm)	P1 (mm)	W (mm)	Pin1 Quadrant
HD3SS3412ARUAR	WQFN	RUA	42	3000	330.0	24.4	3.9	9.4	1.0	8.0	24.0	Q1
HD3SS3412ARUAT	WQFN	RUA	42	250	180.0	24.4	3.9	9.4	1.0	8.0	24.0	Q1

## TAPE AND REEL BOX DIMENSIONS



\*All dimensions are nominal

Device	Package Type	Package Drawing	Pins	SPQ	Length (mm)	Width (mm)	Height (mm)
HD3SS3412ARUAR	WQFN	RUA	42	3000	367.0	367.0	45.0
HD3SS3412ARUAT	WQFN	RUA	42	250	211.0	193.0	46.0

## GENERIC PACKAGE VIEW

**RUA 42**

**WQFN - 0.8 mm max height**

9 x 3.5, 0.5 mm pitch

PLASTIC QUAD FLATPACK - NO LEAD

This image is a representation of the package family, actual package may vary.  
Refer to the product data sheet for package details.

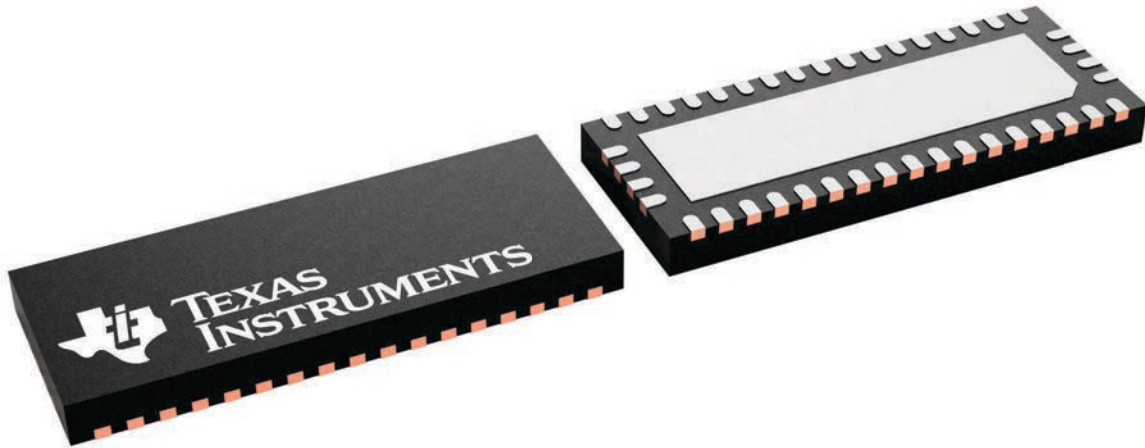

4226504/A

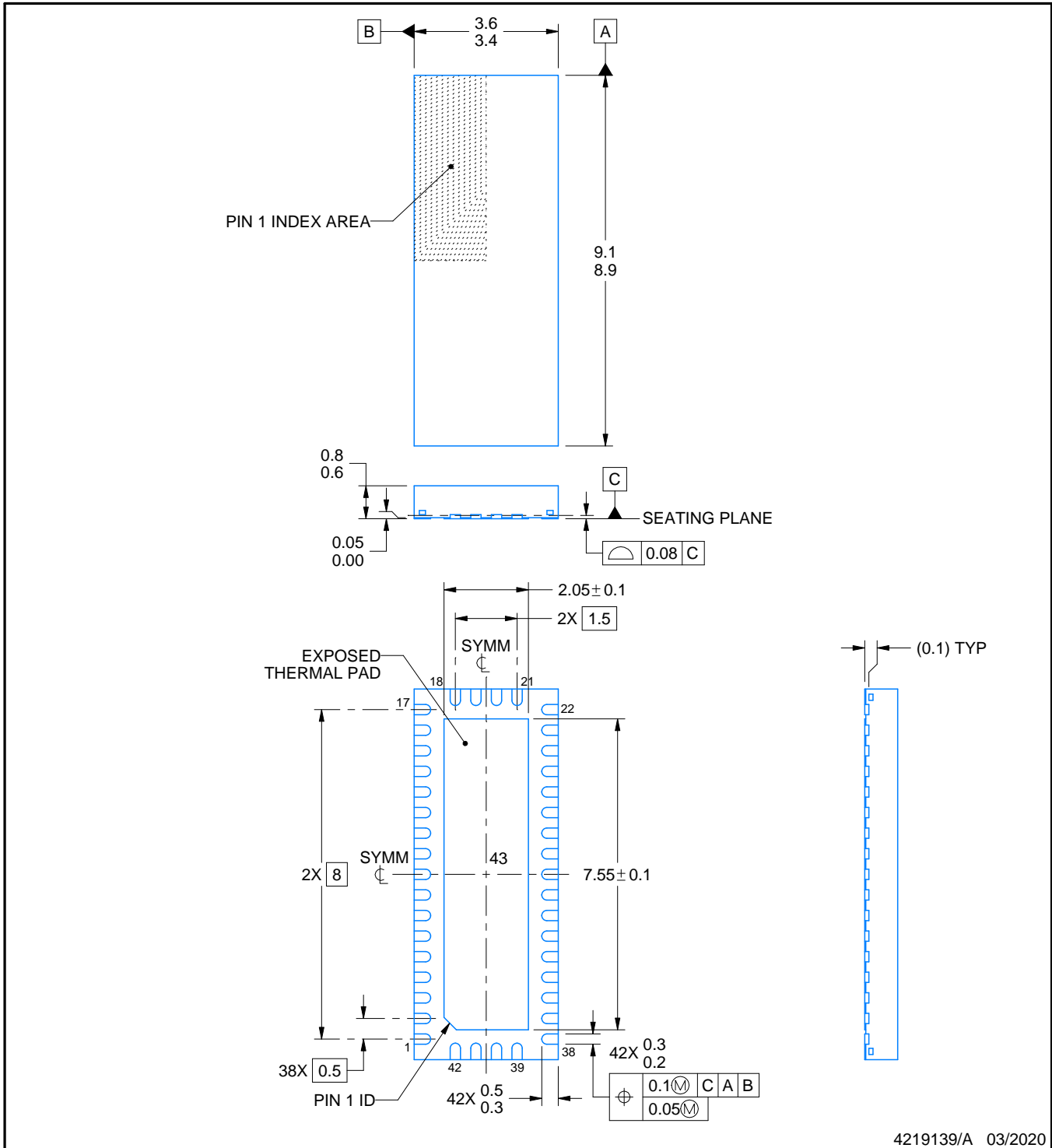

4219139/A 03/2020

NOTES:

1. All linear dimensions are in millimeters. Any dimensions in parenthesis are for reference only. Dimensioning and tolerancing per ASME Y14.5M.
2. This drawing is subject to change without notice.
3. The package thermal pad must be soldered to the printed circuit board for thermal and mechanical performance.



# EXAMPLE BOARD LAYOUT

RUA0042A

WQFN - 0.8 mm max height

PLASTIC QUAD FLATPACK - NO LEAD

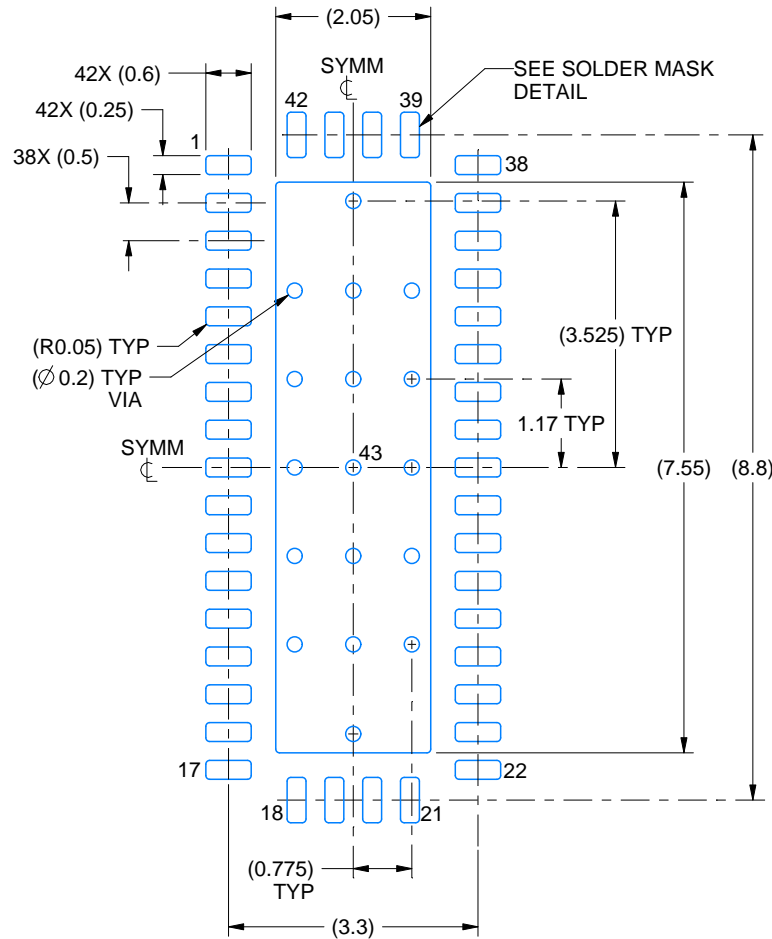

LAND PATTERN EXAMPLE  
EXPOSED METAL SHOWN  
SCALE: 10X

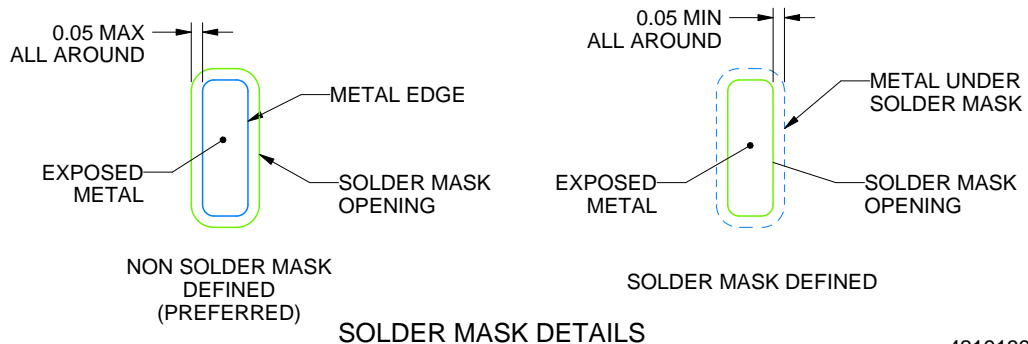

4219139/A 03/2020

NOTES: (continued)

- This package is designed to be soldered to a thermal pad on the board. For more information, see Texas Instruments literature number SLUA271 ([www.ti.com/lit/slua271](http://www.ti.com/lit/slua271)).
- Vias are optional depending on application, refer to device data sheet. If any vias are implemented, refer to their locations shown on this view. It is recommended that vias under paste be filled, plugged or tented.

# EXAMPLE STENCIL DESIGN

RUA0042A

WQFN - 0.8 mm max height

PLASTIC QUAD FLATPACK - NO LEAD

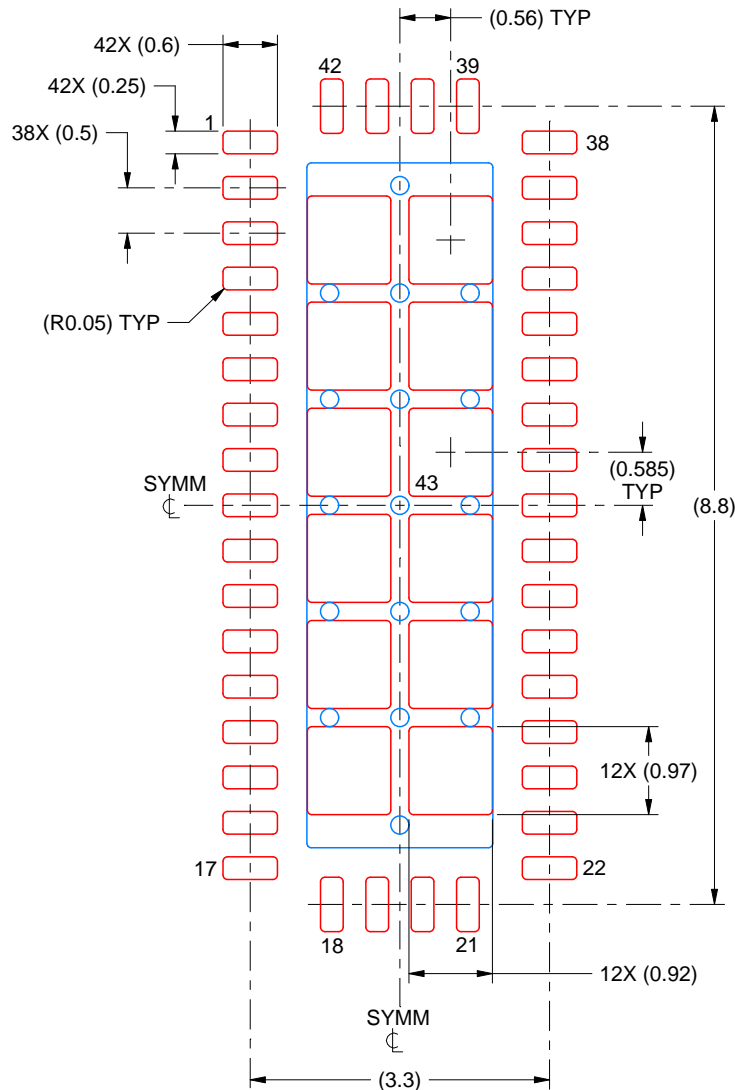

SOLDER PASTE EXAMPLE  
BASED ON 0.125 MM THICK STENCIL  
SCALE: 12X

EXPOSED PAD 43  
69% PRINTED SOLDER COVERAGE BY AREA UNDER PACKAGE

4219139/A 03/2020

NOTES: (continued)

6. Laser cutting apertures with trapezoidal walls and rounded corners may offer better paste release. IPC-7525 may have alternate design recommendations.

## 重要なお知らせと免責事項

TI は、技術データと信頼性データ (データシートを含みます)、設計リソース (リファレンス・デザインを含みます)、アプリケーションや設計に関する各種アドバイス、Web ツール、安全性情報、その他のリソースを、欠陥が存在する可能性のある「現状のまま」提供しており、商品性および特定目的に対する適合性の黙示保証、第三者の知的財産権の非侵害保証を含むいかなる保証も、明示的または黙示的にかかわらず拒否します。

これらのリソースは、TI 製品を使用する設計の経験を積んだ開発者への提供を意図したものです。(1) お客様のアプリケーションに適した TI 製品の選定、(2) お客様のアプリケーションの設計、検証、試験、(3) お客様のアプリケーションが適用される各種規格や、その他のあらゆる安全性、セキュリティ、またはその他の要件を満たしていることを確実にする責任を、お客様のみが単独で負うものとします。上記の各種リソースは、予告なく変更される可能性があります。これらのリソースは、リソースで説明されている TI 製品を使用するアプリケーションの開発の目的でのみ、TI はその使用をお客様に許諾します。これらのリソースに関して、他の目的で複製することや掲載することは禁止されています。TI や第三者の知的財産権のライセンスが付与されている訳ではありません。お客様は、これらのリソースを自身で使用した結果発生するあらゆる申し立て、損害、費用、損失、責任について、TI およびその代理人を完全に補償するものとし、TI は一切の責任を拒否します。

TI の製品は、TI の販売約款 (<https://www.tij.co.jp/ja-jp/legal/terms-of-sale.html>)、または [ti.com](https://www.ti.com) やかかる TI 製品の関連資料などのいずれかを通じて提供する適用可能な条項の下で提供されています。TI がこれらのリソースを提供することは、適用される TI の保証または他の保証の放棄の拡大や変更を意味するものではありません。

日本語版 日本テキサス・インスツルメンツ合同会社  
Copyright © 2021, Texas Instruments Incorporated