

LM284x SIMPLE SWITCHER® 4.5V~42V 入力、0.1、0.3、0.6A 出力、 降圧型 DC/DC レギュレータ、薄型 SOT パッケージ

1 特長

- 入力電圧：4.5V~42V
- 100mA、300mA、600mA の出力電流オプション
- 0.765V の帰還ピン電圧
- 550kHz (X) または 1.25MHz (Y) のスイッチング周波数
- 低いシャットダウン I_Q ：16 μ A (標準値)
- 短絡保護
- 内部補償
- ソフトスタート回路
- ソリューション全体のサイズの小型化 (SOT-6L パッケージ)
- WEBENCH® Power Designer により、LM2840 (または LM2841/42) を使用するカスタム設計を作成

2 アプリケーション

- バッテリ駆動の機器
- 産業用分散電源アプリケーション
- ポータブル・メディア・プレーヤ
- 携帯用ハンドヘルド計測器

3 概要

LM284x SIMPLE SWITCHER™ デバイスは、PWM DC/DC バック (降圧型) レギュレータです。4.5V~42V の範囲の入力電圧で動作するため、レギュレートされていないソースからのパワー・コンディショニングなど、広範なアプリケーションに適しています。R_{DS(on)}の低い(標準値 0.9 Ω)内部スイッチにより、最高の効率を実現しています(標準値85%)。動作周波数は550kHz (Xオプション)および1.25MHz (Yオプション)に固定され、小型の外部部品を使用可能にしながら、低い出力電圧リップルを実現しています。シャットダウン (SHDN) ピンと外部の RC 回路を使用してソフトスタートを実装できるため、ユーザーは特定のアプリケーションに応じてソフトスタート時間を変更できます。

LM2840 は最大 100mA、LM2841 は最大 300mA、LM2842 は最大 600mAの負荷電流に最適化されています。いずれのデバイスも、公称帰還電圧は 0.765V です。

追加機能として、サーマル・シャットダウン、V_{IN} 低電圧誤動作防止、ゲート・ドライブ低電圧誤動作防止が搭載されています。LM284x は、低プロファイルの SOT-6L パッケージで供給されます。

製品情報⁽¹⁾

型番	パッケージ	本体サイズ(公称)
LM2840、LM2841、LM2842	SOT (6)	1.60mmx2.90mm

(1) 提供されているすべてのパッケージについては、データシートの末尾にある注文情報を参照してください。

代表的なアプリケーション回路

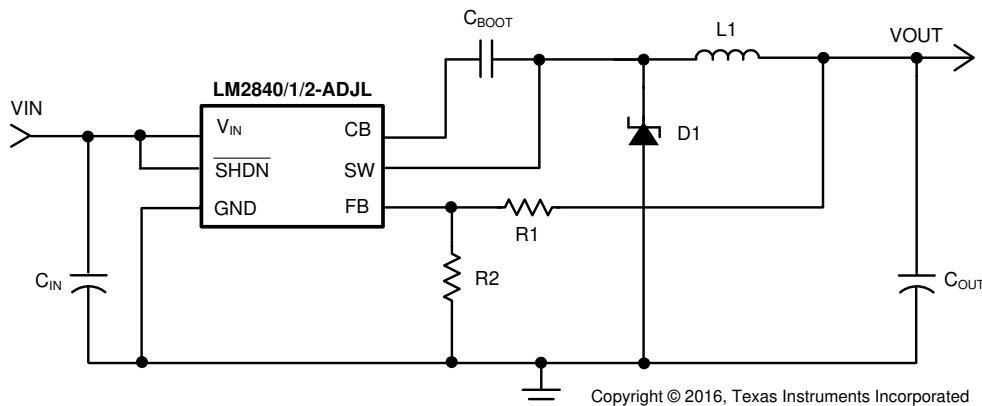

目次

1	特長	1	8	Application and Implementation	11
2	アプリケーション	1	8.1	Application Information	11
3	概要	1	8.2	Typical Applications	11
4	改訂履歴	2	9	Power Supply Recommendations	16
5	Pin Configuration and Functions	3	10	Layout	16
6	Specifications	4	10.1	Layout Guidelines	16
6.1	Absolute Maximum Ratings	4	10.2	Layout Example	16
6.2	ESD Ratings	4	11	デバイスおよびドキュメントのサポート	17
6.3	Recommended Operating Conditions	4	11.1	デバイス・サポート	17
6.4	Thermal Information	4	11.2	ドキュメントのサポート	17
6.5	Electrical Characteristics	5	11.3	関連リンク	17
6.6	Typical Characteristics	7	11.4	ドキュメントの更新通知を受け取る方法	17
7	Detailed Description	9	11.5	コミュニティ・リソース	17
7.1	Overview	9	11.6	商標	18
7.2	Functional Block Diagram	9	11.7	静電気放電に関する注意事項	18
7.3	Feature Description	9	11.8	Glossary	18
7.4	Device Functional Modes	10	12	メカニカル、パッケージ、および注文情報	18

4 改訂履歴

資料番号末尾の英字は改訂を表しています。その改訂履歴は英語版に準じています。

Revision J (February 2017) から Revision K に変更	Page
• 車載用データシートを別のドキュメント (SNVSBE5) に分割し、車載用固有のコンテンツを SNVS540 から削除	1
• データシートのタイトルに SIMPLE SWITCHER® を追加	1

Revision I (September 2016) から Revision J に変更	Page
• Added new text for Pin 4	3
• Added this new line of text in Shutdown Operation section	13

Revision H (April 2013) から Revision I に変更	Page
• 「ESD定格」表、「機能説明」セクション、「デバイスの機能モード」セクション、「アプリケーションと実装」セクション、「電源に関する推奨事項」セクション、「レイアウト」セクション、「デバイスおよびドキュメントのサポート」セクション、「メカニカル、パッケージ、および注文情報」セクションを追加	1
• Added Thermal Information table	4

Revision G (April 2013) から Revision H に変更	Page
• ナショナル セミコンダクターのデータシートのレイアウトを TI フォーマットへ 変更	1

5 Pin Configuration and Functions

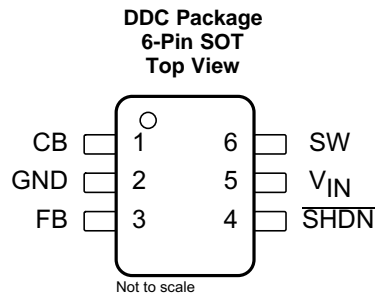

Pin Functions

PIN		I/O	DESCRIPTION
NO.	NAME		
1	CB	I	SW FET gate bias voltage. Connect C_{BOOT} capacitor between CB and SW.
2	GND	—	Ground connection
3	FB	I	Feedback pin: Set feedback voltage divider ratio with $V_{OUT} = V_{FB} (1 + (R1 / R2))$. Resistors must be from 100 Ω to 10 k Ω to avoid input bias errors.
4	$\overline{\text{SHDN}}$	I	Logic level shutdown input. Pull to GND to disable the device and pull high to enable the device. If this function is not used tie to V_{IN} . DO NOT ALLOW TO FLOAT.
5	V_{IN}	I	Power input voltage pin: 4.5-V to 42-V normal operating range.
6	SW	O	Power FET output: Connect to inductor, diode, and C_{BOOT} capacitor.

6 Specifications

6.1 Absolute Maximum Ratings

See ⁽¹⁾⁽²⁾

	MIN	MAX	UNIT
V _{IN}	-0.3	45	V
SHDN	-0.3	(V _{IN} + 0.3 V) < 45	V
SW voltage	-0.3	45	V
CB voltage above SW voltage		7	V
FB voltage	-0.3	5	V
Power dissipation ⁽³⁾	Internally Limited		
Maximum junction temperature		150	°C
Storage temperature, T _{stg}	-65	150	°C

- Stresses beyond those listed under *Absolute Maximum Ratings* may cause permanent damage to the device. These are stress ratings only, which do not imply functional operation of the device at these or any other conditions beyond those indicated under *Recommended Operating Conditions*. Exposure to absolute-maximum-rated conditions for extended periods may affect device reliability.
- If Military/Aerospace specified devices are required, contact the Texas Instruments Sales Office/Distributors for availability and specifications.
- The maximum allowable power dissipation is a function of the maximum junction temperature, T_{J(MAX)}, the junction-to-ambient thermal resistance, R_{θJA}, and the ambient temperature, T_A. The maximum allowable power dissipation at any ambient temperature is calculated using: P_{D (MAX)} = (T_{J(MAX)} - T_A) / R_{θJA}. Exceeding the maximum allowable power dissipation causes excessive die temperature, and the regulator goes into thermal shutdown. Internal thermal shutdown circuitry protects the device from permanent damage. Thermal shutdown engages at T_J=175°C (typical) and disengages at T_J= 155°C (typical).

6.2 ESD Ratings

	VALUE	UNIT
V _(ESD) Electrostatic discharge Human-body model (HBM), per ANSI/ESDA/JEDEC JS-001 ⁽¹⁾	±2000	V

- JEDEC document JEP155 states that 500-V HBM allows safe manufacturing with a standard ESD control process.

6.3 Recommended Operating Conditions

over operating free-air temperature range (unless otherwise noted)

	MIN	MAX	UNIT
Operating junction temperature ⁽¹⁾	-40	125	°C
Input voltage V _{IN}	4.5	42	V
SW voltage		42	V

- All limits specified at room temperature (T_A = 25°C) unless otherwise specified. All room temperature limits are 100% production tested. All limits at temperature extremes are ensured through correlation using standard Statistical Quality Control (SQC) methods. All limits are used to calculate Average Outgoing Quality Level (AOQL).

6.4 Thermal Information

THERMAL METRIC ⁽¹⁾		LM284x	UNIT
		DDC (SOT)	
		6 PINS	
R _{θJA}	Junction-to-ambient thermal resistance ⁽²⁾⁽³⁾	121	°C/W
R _{θJC(top)}	Junction-to-case (top) thermal resistance	94	°C/W

- For more information about traditional and new thermal metrics, see the *Semiconductor and IC Package Thermal Metrics* application report.
- The package thermal impedance is calculated in accordance to JESD 51-7.
- Thermal Resistances were simulated on a 4-layer, JEDEC board

6.5 Electrical Characteristics

Specifications are for $T_J = 25^\circ\text{C}$ unless otherwise specified. Minimum and Maximum limits are specified through test, design, or statistical correlation. Typical values represent the most likely parametric norm at $T_J = 25^\circ\text{C}$, and are provided for reference purposes only. Unless otherwise stated the following conditions apply: $V_{IN} = 12\text{ V}$.⁽¹⁾⁽²⁾⁽³⁾

PARAMETER		TEST CONDITIONS		MIN	TYP	MAX	UNIT	
I_Q	Quiescent current	$\overline{\text{SHDN}} = 0\text{ V}$			16		μA	
			$T_J = -40^\circ\text{C}$ to 125°C			40		
		Device ON, not switching				1.3		mA
			$T_J = -40^\circ\text{C}$ to 125°C				1.75	
Device ON, no load				1.35		mA		
$T_J = -40^\circ\text{C}$ to 125°C					1.85			
$R_{\text{DS(ON)}}$	Switch ON resistance	See ⁽⁴⁾			0.9		Ω	
			$T_J = -40^\circ\text{C}$ to 125°C					1.6
I_{LSW}	Switch leakage current	$V_{\text{IN}} = 42\text{ V}$			0		μA	
			$T_J = -40^\circ\text{C}$ to 125°C					0.5
I_{CL}	Switch current limit	LM2840 ⁽⁵⁾			525		mA	
			$T_J = -40^\circ\text{C}$ to 125°C					900
		LM2841 ⁽⁵⁾				525		mA
			$T_J = -40^\circ\text{C}$ to 125°C				900	
		LM2842 ⁽⁵⁾				1.15		A
			$T_J = -40^\circ\text{C}$ to 125°C				1.7	
I_{FB}	Feedback pin bias current	LM284[0,1,2] ⁽⁶⁾			0.1		μA	
			$T_J = -40^\circ\text{C}$ to 125°C					1
V_{FB}	FB Pin reference voltage				0.765		V	
		$T_J = -40^\circ\text{C}$ to 125°C			0.747	0.782		
$t_{\text{ON(min)}}$	Minimum ON-time	See ⁽⁷⁾			100		ns	
			$T_J = -40^\circ\text{C}$ to 125°C					150
$t_{\text{OFF(min)}}$	Minimum OFF-time	X option			110		ns	
			$T_J = -40^\circ\text{C}$ to 125°C					370
		Y option				104		ns
			$T_J = -40^\circ\text{C}$ to 125°C				200	
f_{SW}	Switching frequency	X option, $V_{\text{FB}} = 0.5\text{ V}$			550		kHz	
			$T_J = -40^\circ\text{C}$ to 125°C			325		750
		X option, $V_{\text{FB}} = 0\text{ V}$				140		MHz
			$T_J = -40^\circ\text{C}$ to 125°C				1.25	
		Y option, $V_{\text{FB}} = 0.5\text{ V}$				0.95	1.5	MHz
			$T_J = -40^\circ\text{C}$ to 125°C					
D_{MAX}	Maximum duty cycle	X option			94%			
			$T_J = -40^\circ\text{C}$ to 125°C			88%		
		Y option				87%		
			$T_J = -40^\circ\text{C}$ to 125°C			81%		

(1) All limits specified at room temperature ($T_A = 25^\circ\text{C}$) unless otherwise noted. Room temperature limits are production tested. Limits at temperature extremes are ensured through correlation using standard Statistical Quality Control (SQC) methods. Limits are used to calculate Average Outgoing Quality Level (AOQL).

(2) Typical numbers are at 25°C and represent the most likely norm.

(3) The part numbers in this table represent both the Q1 and non-Q1 versions of the respective parts.

(4) Includes the bond wires, $R_{\text{DS(ON)}}$ from V_{IN} pin to SW pin.

(5) Current limit at 0% duty cycle. May be lower at higher duty cycle or input voltages below 6 V.

(6) Bias currents flow into pin.

(7) Minimum ON-time specified by design and simulation.

Electrical Characteristics (continued)

Specifications are for $T_J = 25^\circ\text{C}$ unless otherwise specified. Minimum and Maximum limits are specified through test, design, or statistical correlation. Typical values represent the most likely parametric norm at $T_J = 25^\circ\text{C}$, and are provided for reference purposes only. Unless otherwise stated the following conditions apply: $V_{IN} = 12\text{ V}$.⁽¹⁾⁽²⁾⁽³⁾

PARAMETER		TEST CONDITIONS		MIN	TYP	MAX	UNIT
V_{UVP}	Undervoltage lockout thresholds	On threshold			3.7		V
			$T_J = -40^\circ\text{C}$ to 125°C	4.4			
		Off threshold			3.5		
			$T_J = -40^\circ\text{C}$ to 125°C			3.25	
$V_{\overline{\text{SHDN}}}$	Shutdown threshold	Device ON			1		V
			$T_J = -40^\circ\text{C}$ to 125°C	2.3			
		Device OFF			0.9		
			$T_J = -40^\circ\text{C}$ to 125°C			0.3	
$I_{\overline{\text{SHDN}}}$	Shutdown pin input bias current	$V_{\overline{\text{SHDN}}} = 2.3\text{ V}^{(6)}$			0.05		μA
			$T_J = -40^\circ\text{C}$ to 125°C			1.5	
		$V_{\overline{\text{SHDN}}} = 0\text{ V}$			0.02		
			$T_J = -40^\circ\text{C}$ to 125°C			1.5	

6.6 Typical Characteristics

The part numbers in this section represent both the Q1 and non-Q1 versions of the respective parts.

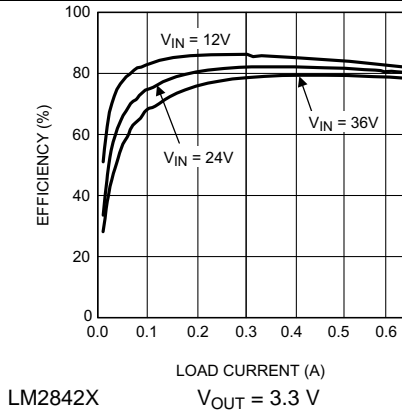

Figure 1. Efficiency vs Load Current

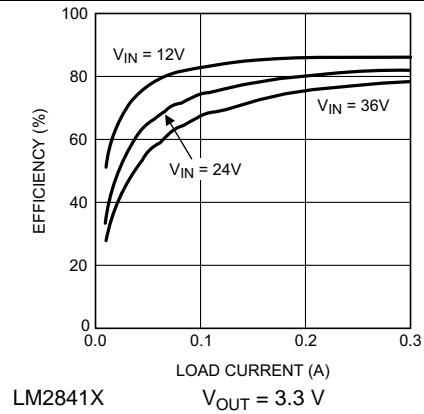

Figure 2. Efficiency vs Load Current

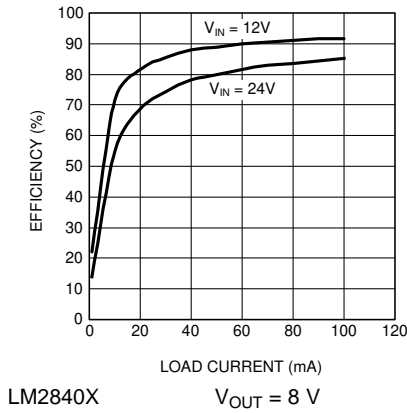

Figure 3. Efficiency vs Load Current

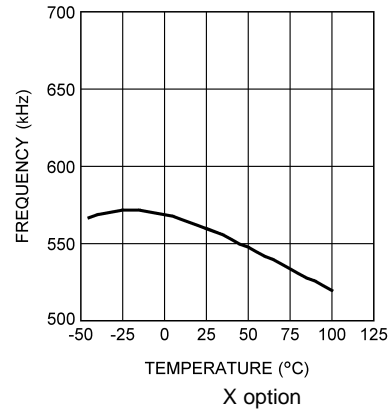

Figure 4. Switching Frequency vs Temperature

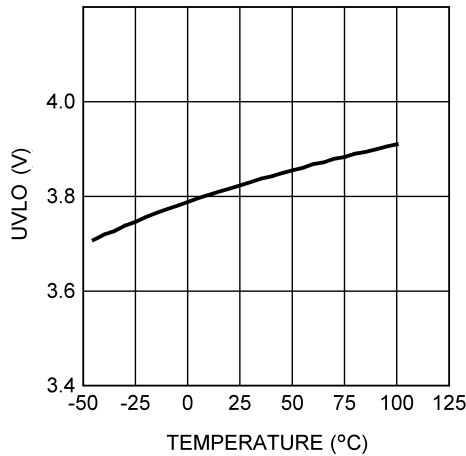

Figure 5. Input UVLO Voltage vs Temperature

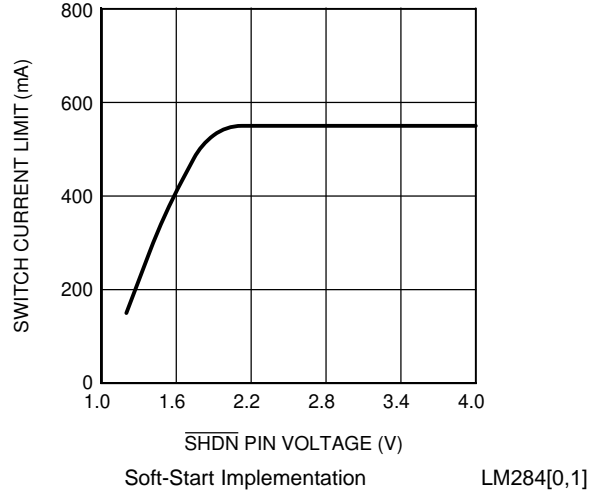
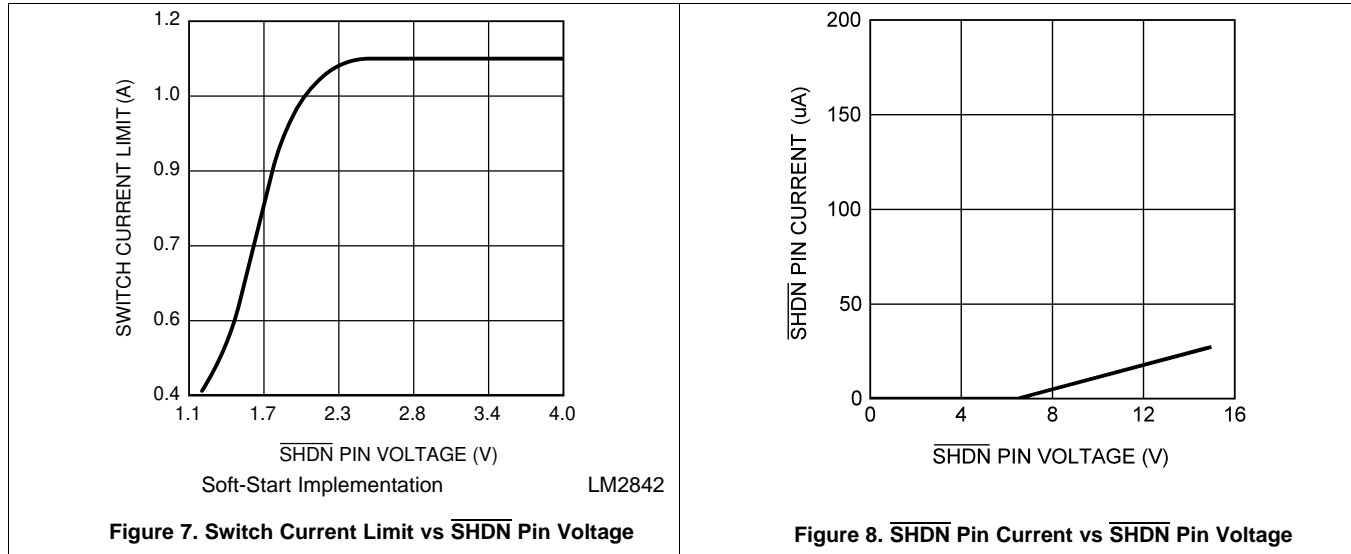

Figure 6. Switch Current Limit vs $\overline{\text{SHDN}}$ Pin Voltage

Typical Characteristics (continued)

The part numbers in this section represent both the Q1 and non-Q1 versions of the respective parts.



7 Detailed Description

7.1 Overview

The LM284x SIMPLE SWITCHER® regulators are easy-to-use, non-synchronous, step-down DC/DC converters with a wide input voltage range up to 42 V. The devices are capable of delivering up to 100-mA, 300-mA, or 600-mA DC load current with excellent line and load regulation. These devices are available in fixed frequency of 550 kHz and 1.25 MHz. The family requires few external components, and the pin arrangement was designed for simple, optimum PCB layout.

7.2 Functional Block Diagram

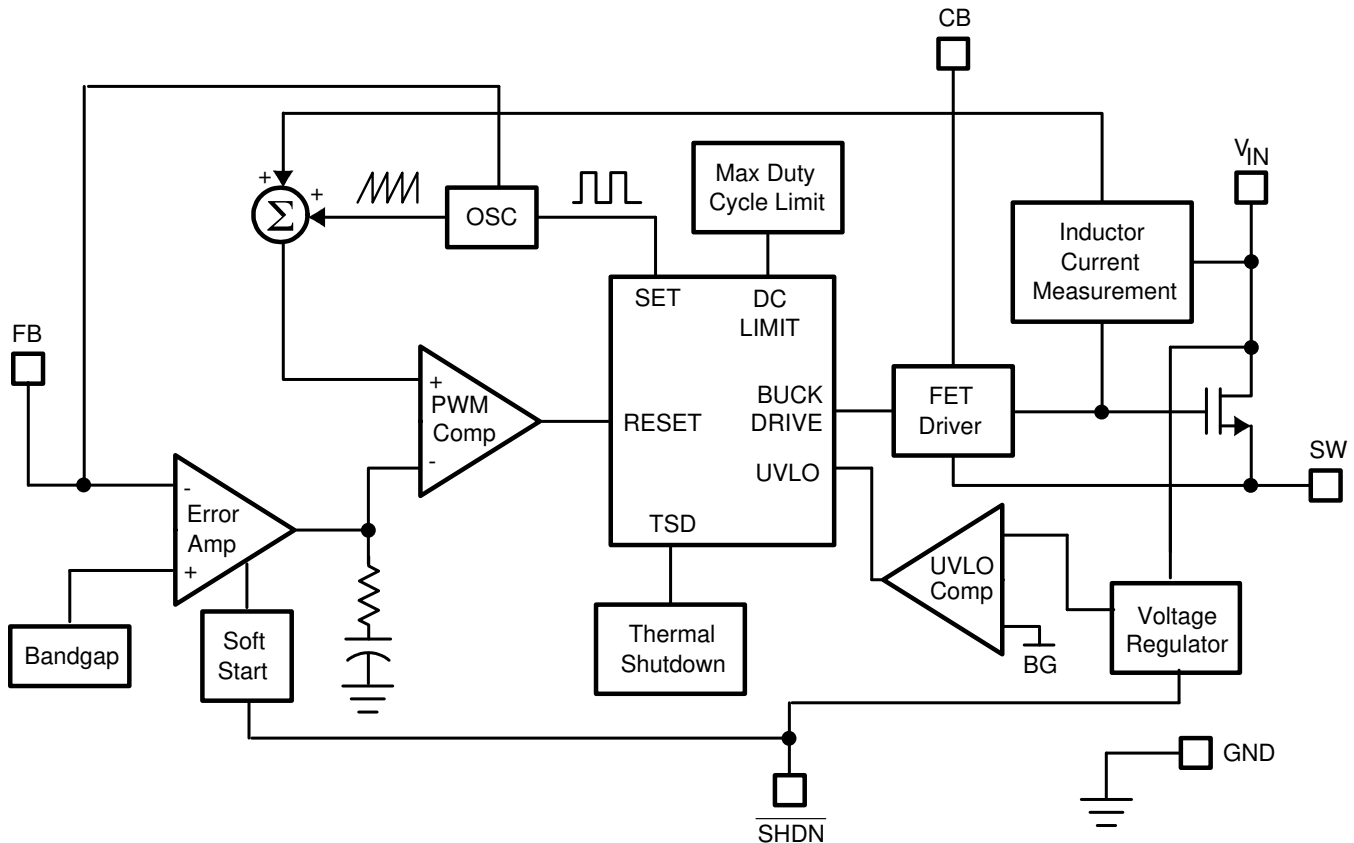

Copyright © 2016, Texas Instruments Incorporated

7.3 Feature Description

7.3.1 Protection

The LM284x have dedicated protection circuitry running during normal operation to protect the IC. The thermal shutdown circuitry turns off the power device when the die temperature reaches excessive levels. The UVLO comparator protects the power device during supply power start-up and shutdown to prevent operation at voltages less than the minimum input voltage. A gate drive (CB) undervoltage lockout is included to ensure that there is enough gate drive voltage to drive the MOSFET before the device tries to start switching. The LM284x also feature a shutdown mode decreasing the supply current to approximately 16 μ A.

7.4 Device Functional Modes

7.4.1 Continuous Conduction Mode

The LM284x contain a current-mode, PWM buck regulator. A buck regulator steps the input voltage down to a lower output voltage. In continuous conduction mode (when the inductor current never reaches zero at steady-state operation), the buck regulator operates in two cycles. The power switch is connected between V_{IN} and SW. In the first cycle of operation the transistor is closed and the diode is reverse biased. Energy is collected in the inductor and the load current is supplied by C_{OUT} and the rising current through the inductor. During the second cycle the transistor is open and the diode is forward biased due to the fact that the inductor current cannot instantaneously change direction. The energy stored in the inductor is transferred to the load and output capacitor. The ratio of these two cycles determines the output voltage. The output voltage is defined approximately as shown in [Equation 1](#).

$$D = V_{OUT} / V_{IN} \quad (1)$$

$$D' = (1 - D)$$

where

- D is the duty cycle of the switch (2)

D and D' are required for design calculations.

8 Application and Implementation

NOTE

Information in the following applications sections is not part of the TI component specification, and TI does not warrant its accuracy or completeness. TI's customers are responsible for determining suitability of components for their purposes. Customers should validate and test their design implementation to confirm system functionality.

8.1 Application Information

The LM284x are step-down DC/DC regulators. They are typically used to convert a higher DC voltage to a lower DC voltage with a maximum output current of 100 mA, 300 mA, or 600 mA. The following design procedure can be used to select components for the LM284x. Alternately, the WEBENCH® software may be used to generate complete designs. When generating a design, the WEBENCH software uses iterative design procedure and accesses comprehensive databases of components. See ti.com and [Detailed Design Procedure](#) for more details.

8.2 Typical Applications

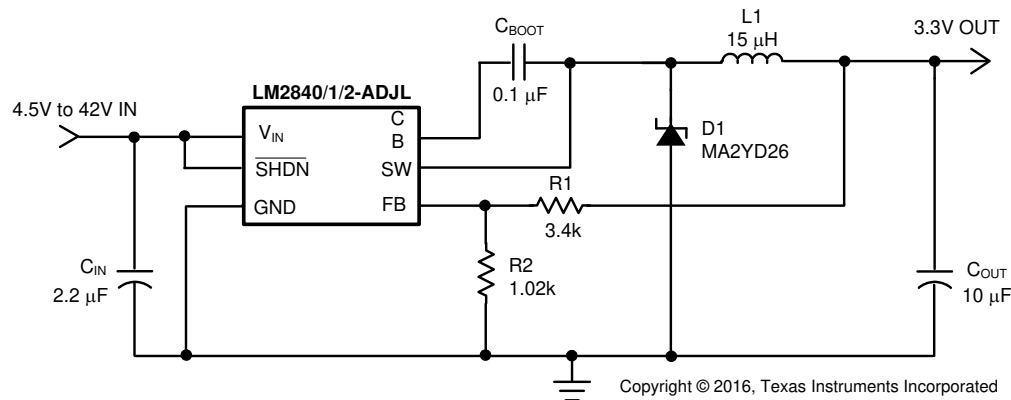

Figure 9. Application Circuit With 3.3-V Output Voltage at 100 mA

8.2.1 Design Requirements

Table 1 lists the design parameters for this example.

Table 1. Design Parameters

DESIGN PARAMETER	EXAMPLE VALUE
Input voltage	4.5 V to 42 V
Output voltage	3.3 V
Output current	0.1 A

8.2.2 Detailed Design Procedure

8.2.2.1 Custom Design With WEBENCH® Tools

[Click here](#) to create a custom design using the LM2840 device with the WEBENCH® Power Designer.

1. Start by entering the input voltage (V_{IN}), output voltage (V_{OUT}), and output current (I_{OUT}) requirements.
2. Optimize the design for key parameters such as efficiency, footprint, and cost using the optimizer dial.
3. Compare the generated design with other possible solutions from Texas Instruments.

The WEBENCH Power Designer provides a customized schematic along with a list of materials with real-time pricing and component availability.

In most cases, these actions are available:

- Run electrical simulations to see important waveforms and circuit performance

- Run thermal simulations to understand board thermal performance
- Export customized schematic and layout into popular CAD formats
- Print PDF reports for the design, and share the design with colleagues

Get more information about WEBENCH tools at www.ti.com/WEBENCH.

This section presents guidelines for selecting external components.

8.2.2.2 Setting the Output Voltage

The output voltage is set using the feedback pin and a resistor divider connected to the output as shown in [代表的なアプリケーション回路](#). The feedback pin voltage 0.765 V, so the ratio of the feedback resistors sets the output voltage according to [Equation 3](#):

$$V_{OUT} = 0.765 \text{ V} (1 + (R1 / R2)) \quad (3)$$

Typically R2 is given as 100 Ω to 10 kΩ for a starting value. To solve for R1 given R2 and V_{OUT} , use [Equation 4](#):

$$R1 = R2 ((V_{OUT} / 0.765 \text{ V}) - 1) \quad (4)$$

8.2.2.3 Inductor Selection

The most critical parameters for the inductor are the inductance, peak current, and the DC resistance. The inductance is related to the peak-to-peak inductor ripple current, the input and the output voltages.

$$L = \frac{(V_{IN} - V_{OUT})V_{OUT}}{V_{IN} \times I_{RIPPLE} \times f_{SW}} \quad (5)$$

A higher value of ripple current reduces inductance, but increases the conduction loss, core loss, and current stress for the inductor and switch devices. It also requires a bigger output capacitor for the same output voltage ripple requirement. A reasonable value is setting the ripple current to be 30% of the DC output current. Because the ripple current increases with the input voltage, the maximum input voltage is always used to determine the inductance. The DC resistance of the inductor is a key parameter for the efficiency. Lower DC resistance is available with a bigger winding area. A good tradeoff between the efficiency and the core size is letting the inductor copper loss equal 2% of the output power. See [Selecting Inductors for Buck Converters](#) for more information on selecting inductors. A good starting point for most applications is a 10 μH to 22 μH with 1.1 A or greater current rating for the LM2842 or a 0.7 A or greater current rating for the LM284x. Using such a rating enables the device to current limit without saturating the inductor. This is preferable to the device going into thermal shutdown mode and the possibility of damaging the inductor if the output is shorted to ground or other long-term overload.

Table 2. Recommended Inductors

MANUFACTURER	INDUCTOR	CONTACT INFORMATION
Coilcraft	LPS4018, DO1608C, DO3308, and LPO2506 series	www.coilcraft.com 800-3222645
MuRata	LQH55D and LQH66S series	www.murata.com
Coiltronics	MP2 and MP2A series	www.cooperbusman.com

8.2.2.4 Input Capacitor

A low ESR ceramic capacitor (C_{IN}) is needed between the V_{IN} pin and GND pin. This capacitor prevents large voltage transients from appearing at the input. Use a 2.2-μF to 10-μF value with X5R or X7R dielectric. Depending on construction, a ceramic capacitor's value can decrease up to 50% of its nominal value when rated voltage is applied. Consult with the capacitor manufacturer's data sheet for information on capacitor derating over voltage and temperature.

8.2.2.5 Output Capacitor

The selection of C_{OUT} is driven by the maximum allowable output voltage ripple. The output ripple in the constant frequency, PWM mode is approximated by Equation 6.

$$V_{RIPPLE} = I_{RIPPLE} (ESR + (1 / (8f_{SW}C_{OUT}))) \quad (6)$$

The ESR term usually plays the dominant role in determining the voltage ripple. Low-ESR ceramic capacitors are recommended. Capacitors in the range of 22 μ F to 100 μ F are a good starting point with an ESR of 0.1 Ω or less.

Table 3. Recommended Input and Output Capacitors

MANUFACTURER	CAPACITOR	CONTACT INFORMATION
Vishay Sprague	293D, 592D, and 595D series tantalum	www.vishay.com 407-324-4140
Taiyo Yuden	High capacitance MLCC ceramic	www.t-yuden.com 408-573-4150
Cornell Dubilier	ESRD series Polymer Aluminum Electrolytic SPV and AFK series V-chip series	www.cde.com
MuRata	High capacitance MLCC ceramic	www.murata.com

8.2.2.6 Bootstrap Capacitor

A 0.15- μ F ceramic capacitor or larger is recommended for the bootstrap capacitor (C_{BOOT}). For applications where the input voltage is less than twice the output voltage a larger capacitor is recommended, generally 0.15 μ F to 1 μ F to ensure plenty of gate drive for the internal switches and a consistently low $R_{DS(ON)}$.

8.2.2.7 Soft-Start Components

The devices have circuitry that is used in conjunction with the \overline{SHDN} pin to limit the inrush current on start-up of the DC/DC switching regulator. The \overline{SHDN} pin in conjunction with a RC filter is used to tailor the soft start for a specific application. When a voltage applied to the \overline{SHDN} pin is between 0 V and up to 2.3 V it causes the cycle-by-cycle current limit in the power stage to be modulated for minimum current limit at 0 V up to the rated current limit at 2.3 V. Thus controlling the output rise time and inrush current at start-up. The resistor value must be selected so the current injected into the \overline{SHDN} pin is greater than the leakage current of the \overline{SHDN} pin (1.5 μ A) when the voltage at \overline{SHDN} is equal or greater than 2.3 V.

8.2.2.8 Shutdown Operation

The \overline{SHDN} pin of the LM284x is designed so that it may be controlled using 2.3 V or higher logic signals. If the shutdown function is not to be used the \overline{SHDN} pin may be tied to V_{IN} . This input must not be allowed to float

The maximum voltage to the \overline{SHDN} pin should not exceed 42 V. If the use of a higher voltage is desired due to system or other constraints it may be used; however, a 100 k Ω or larger resistor is recommended between the applied voltage and the \overline{SHDN} pin to protect the device.

8.2.2.9 Schottky Diode

The breakdown voltage rating of the diode (D1) is preferred to be 25% higher than the maximum input voltage. The current rating for the diode must be equal to the maximum output current for best reliability in most applications. In cases where the duty cycle is greater than 50%, the average diode current is lower. In this case it is possible to use a diode with a lower average current rating, approximately $(1 - D)I_{OUT}$; however, the peak current rating should be higher than the maximum load current. A 0.5-A to 1-A rated diode is a good starting point.

8.2.3 Application Curves

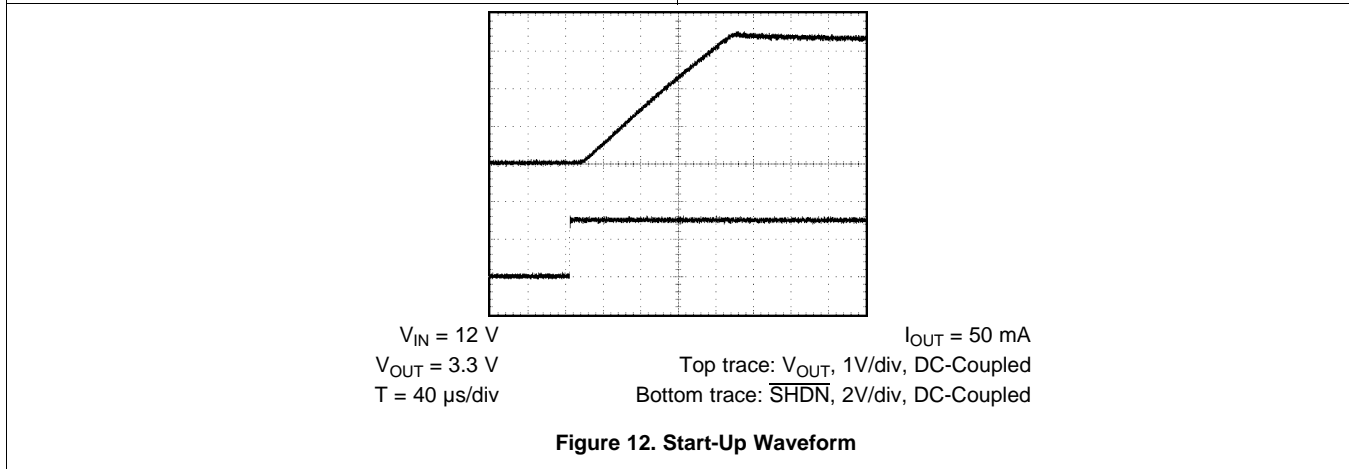
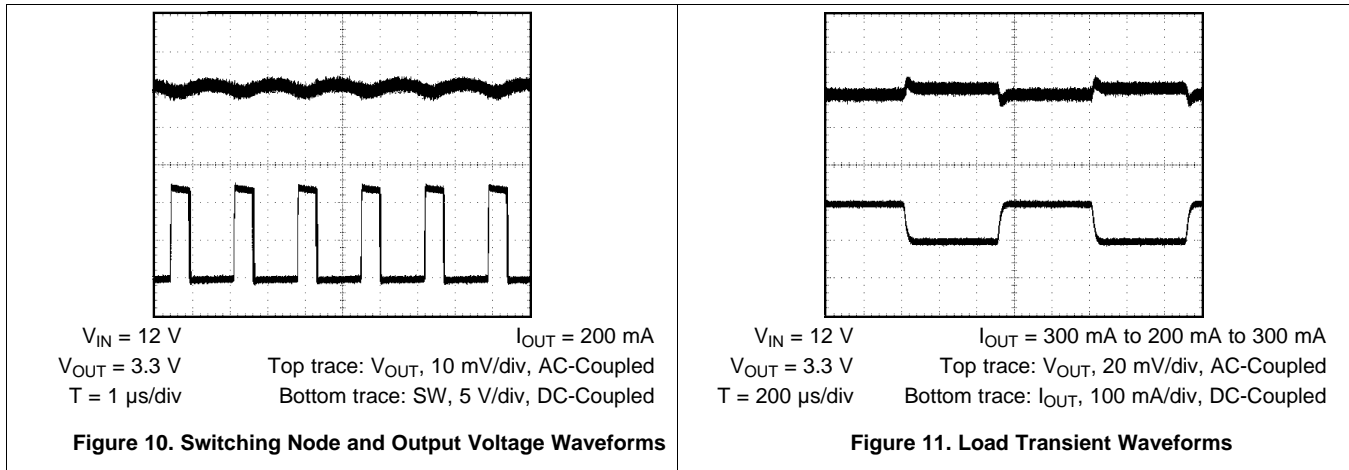

8.2.4 Other Application Circuits

Figure 13 to Figure 16 show application circuit examples using the LM284x devices. Customers must fully validate and test these circuits before implementing a design based on these examples. Unless otherwise noted, the design procedures in are applicable to these designs.

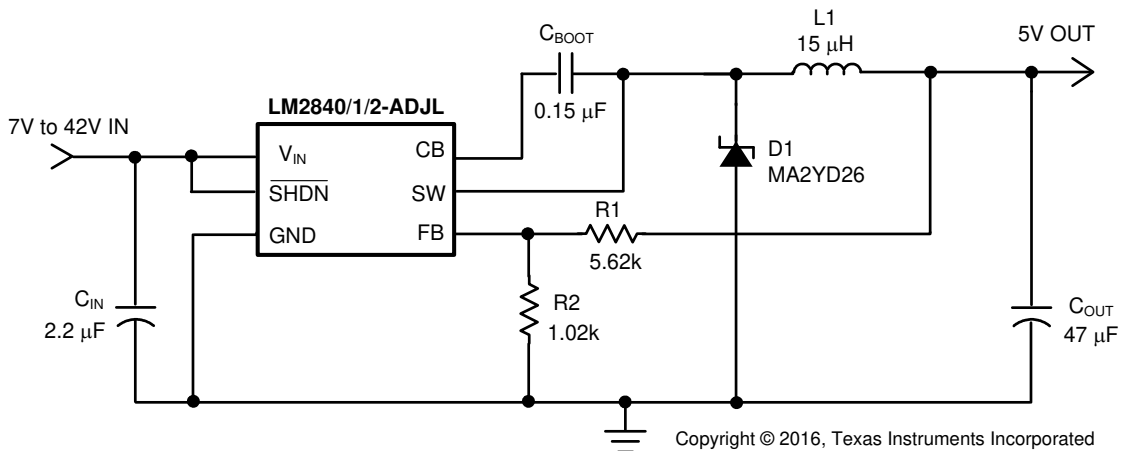

Figure 13. Step-Down Converter With 5-V Output Voltage

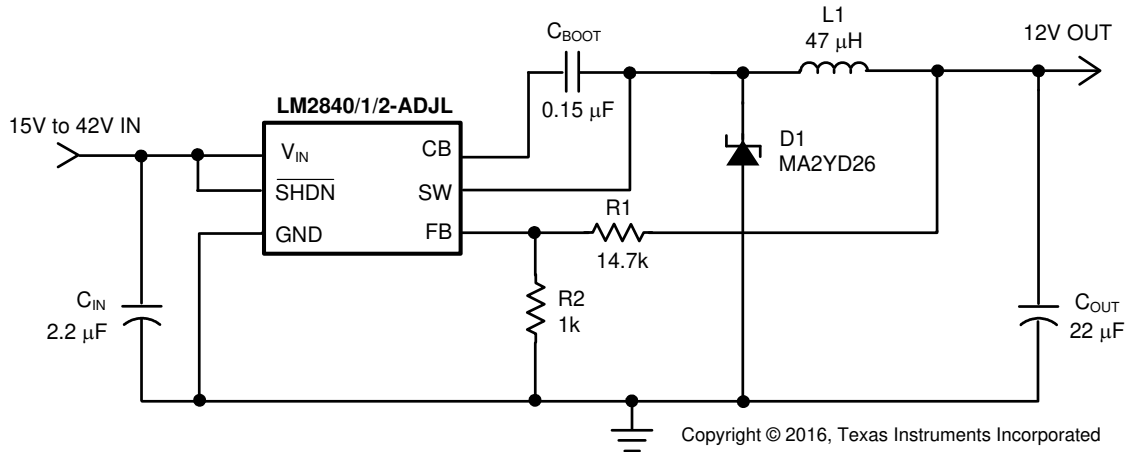

Figure 14. Step-Down Converter With 12-V Output Voltage

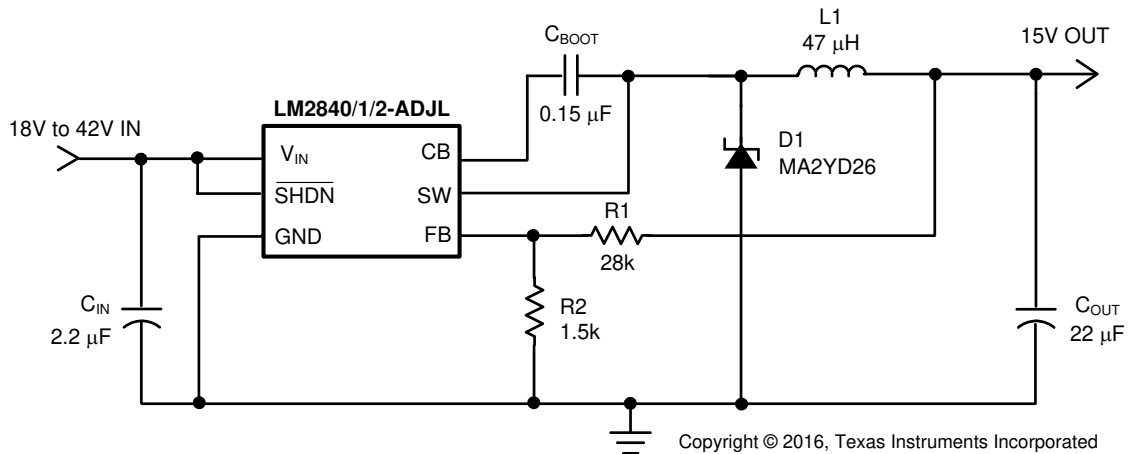

Figure 15. Step-Down Converter With 15-V Output Voltage

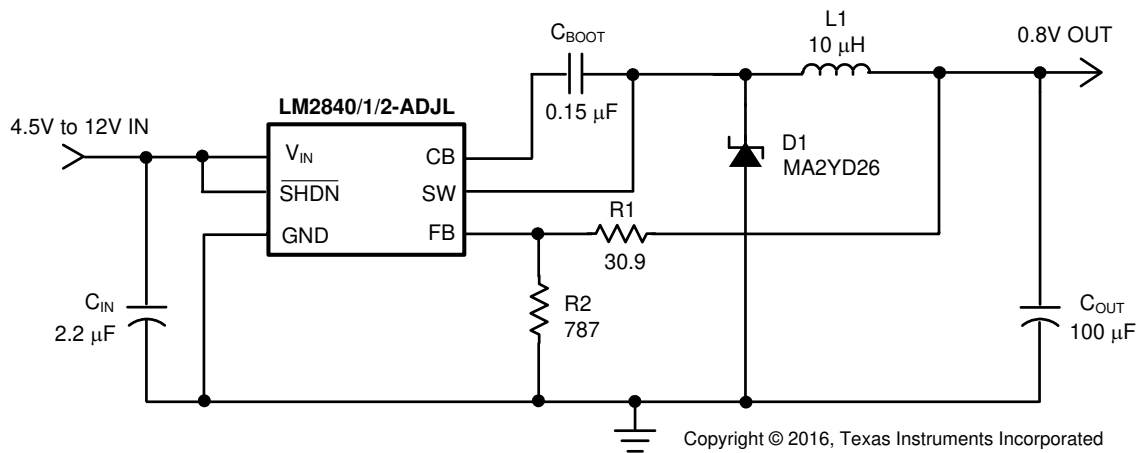

Figure 16. Step-Down Converter With 0.8-V Output Voltage

9 Power Supply Recommendations

The LM284x are designed to operate from an input voltage supply range between 4 V and 42 V. This input supply must be able to withstand the maximum input current and maintain a voltage above 4.5 V. The resistance of the input supply rail must be low enough that an input current transient does not cause a drop at the device supply voltage high enough to cause a false UVLO fault triggering and system reset. If the input supply is located more than a few inches from the device, additional bulk capacitance may be required in addition to the ceramic input capacitors.

10 Layout

10.1 Layout Guidelines

To reduce problems with conducted noise pickup, the ground side of the feedback network should be connected directly to the GND pin with its own connection. The feedback network, resistors R1 and R2, must be kept close to the FB pin, and away from the inductor to minimize coupling noise into the feedback pin. The input bypass capacitor C_{IN} must be placed close to the V_{IN} pin. This reduces copper trace resistance, which effects input voltage ripple of the IC. The inductor L1 must be placed close to the SW pin to reduce EMI and capacitive coupling. The output capacitor, C_{OUT} must be placed close to the junction of L1 and the diode D1. The L1, D1, and C_{OUT} trace must be as short as possible to reduce conducted and radiated noise and increase overall efficiency. The ground connection for the diode, C_{IN} , and C_{OUT} must be as small as possible and tied to the system ground plane in only one spot (preferably at the C_{OUT} ground point) to minimize conducted noise in the system ground plane. See [Layout Guidelines for Switching Power Supplies](#) for more detail on switching power supply layout considerations.

10.2 Layout Example

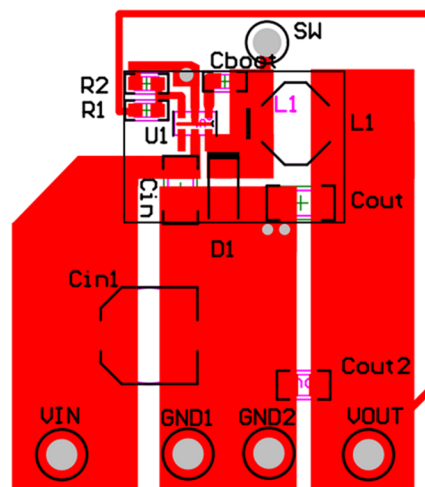

Figure 17. Recommended Layout

11 デバイスおよびドキュメントのサポート

11.1 デバイス・サポート

11.1.1 デベロッパー・ネットワークの製品に関する免責事項

デベロッパー・ネットワークの製品またはサービスに関するTIの出版物は、単独またはTIの製品、サービスと一緒に提供される場合に関係なく、デベロッパー・ネットワークの製品またはサービスの適合性に関する是認、デベロッパー・ネットワークの製品またはサービスの是認の表明を意味するものではありません。

11.1.2 開発サポート

11.1.2.1 WEBENCH®ツールによるカスタム設計

[ここをクリック](#)すると、WEBENCH® Power Designerにより、LM2840デバイスを使用するカスタム設計を作成できます。

1. 最初に、入力電圧(V_{IN})、出力電圧(V_{OUT})、出力電流(I_{OUT})の要件を入力します。
2. オプティマイザのダイヤルを使用して、効率、占有面積、コストなどの主要なパラメータについて設計を最適化します。
3. 生成された設計を、テキサス・インスツルメンツが提供する他の方式と比較します。

WEBENCH Power Designerでは、カスタマイズされた回路図と部品リストを、リアルタイムの価格と部品の在庫情報と併せて参照できます。

通常、次の操作を実行可能です。

- 電氣的なシミュレーションを実行し、重要な波形と回路の性能を確認する。
- 熱シミュレーションを実行し、基板の熱特性を把握する。
- カスタマイズされた回路図やレイアウトを、一般的なCADフォーマットで出力する。
- 設計のレポートをPDFで印刷し、設計を共有する。

WEBENCHツールの詳細は、www.ti.com/WEBENCHでご覧になれます。

11.2 ドキュメントのサポート

11.2.1 関連資料

関連資料については、以下を参照してください。

- 『AN-1197 バック・コンバータ用のインダクタの選択』(SNVA038)
- 『AN-1149 スwitchング電源のレイアウトのガイドライン』(SNVA021)

11.3 関連リンク

次の表に、クイック・アクセス・リンクを示します。カテゴリには、技術資料、サポートおよびコミュニティ・リソース、ツールとソフトウェア、およびご注文へのクイック・アクセスが含まれます。

表 4. 関連リンク

製品	プロダクト・フォルダ	ご注文はこちら	技術資料	ツールとソフトウェア	サポートとコミュニティ
LM2840	ここをクリック	ここをクリック	ここをクリック	ここをクリック	ここをクリック
LM2841	ここをクリック	ここをクリック	ここをクリック	ここをクリック	ここをクリック
LM2842	ここをクリック	ここをクリック	ここをクリック	ここをクリック	ここをクリック

11.4 ドキュメントの更新通知を受け取る方法

ドキュメントの更新についての通知を受け取るには、ti.comのデバイス製品フォルダを開いてください。右上の「アラートを受け取る」をクリックして登録すると、変更されたすべての製品情報に関するダイジェストを毎週受け取れます。変更の詳細については、修正されたドキュメントに含まれている改訂履歴をご覧ください。

11.5 コミュニティ・リソース

The following links connect to TI community resources. Linked contents are provided "AS IS" by the respective contributors. They do not constitute TI specifications and do not necessarily reflect TI's views; see TI's [Terms of Use](#).

コミュニティ・リソース (continued)

TI E2E™ Online Community *TI's Engineer-to-Engineer (E2E) Community*. Created to foster collaboration among engineers. At e2e.ti.com, you can ask questions, share knowledge, explore ideas and help solve problems with fellow engineers.

Design Support *TI's Design Support* Quickly find helpful E2E forums along with design support tools and contact information for technical support.

11.6 商標

SIMPLE SWITCHER, E2E are trademarks of Texas Instruments.
WEBENCH, SIMPLE SWITCHER are registered trademarks of Texas Instruments.
All other trademarks are the property of their respective owners.

11.7 静電気放電に関する注意事項



これらのデバイスは、限定的なESD(静電破壊)保護機能を内蔵しています。保存時または取り扱い時は、MOSゲートに対する静電破壊を防止するために、リード線同士をショートさせておくか、デバイスを導電フォームに入れる必要があります。

11.8 Glossary

SLYZ022 — *TI Glossary*.

This glossary lists and explains terms, acronyms, and definitions.

12 メカニカル、パッケージ、および注文情報

以降のページには、メカニカル、パッケージ、および注文に関する情報が記載されています。この情報は、そのデバイスについて利用可能な最新のデータです。このデータは予告なく変更されることがあり、ドキュメントが改訂される場合もあります。本データシートのブラウザ版を使用されている場合は、画面左側の説明をご覧ください。

PACKAGING INFORMATION

Orderable Device	Status (1)	Package Type	Package Drawing	Pins	Package Qty	Eco Plan (2)	Lead finish/ Ball material (6)	MSL Peak Temp (3)	Op Temp (°C)	Device Marking (4/5)	Samples
LM2840XMK-ADJL/NOPB	ACTIVE	SOT-23-THIN	DDC	6	1000	RoHS & Green	SN	Level-1-260C-UNLIM	-40 to 125	SE8B	Samples
LM2840XMKX-ADJL/NOPB	ACTIVE	SOT-23-THIN	DDC	6	3000	RoHS & Green	SN	Level-1-260C-UNLIM	-40 to 125	SE8B	Samples
LM2840YMK-ADJL/NOPB	ACTIVE	SOT-23-THIN	DDC	6	1000	RoHS & Green	SN	Level-1-260C-UNLIM	-40 to 125	SF1B	Samples
LM2841XMK-ADJL/NOPB	ACTIVE	SOT-23-THIN	DDC	6	1000	RoHS & Green	SN	Level-1-260C-UNLIM	-40 to 125	STFB	Samples
LM2841XMKX-ADJL/NOPB	ACTIVE	SOT-23-THIN	DDC	6	3000	RoHS & Green	SN	Level-1-260C-UNLIM	-40 to 125	STFB	Samples
LM2841YMK-ADJL/NOPB	ACTIVE	SOT-23-THIN	DDC	6	1000	RoHS & Green	SN	Level-1-260C-UNLIM	-40 to 125	STTB	Samples
LM2841YMKX-ADJL/NOPB	ACTIVE	SOT-23-THIN	DDC	6	3000	RoHS & Green	SN	Level-1-260C-UNLIM	-40 to 125	STTB	Samples
LM2842XMK-ADJL/NOPB	ACTIVE	SOT-23-THIN	DDC	6	1000	RoHS & Green	SN	Level-1-260C-UNLIM	-40 to 125	STVB	Samples
LM2842XMKX-ADJL/NOPB	ACTIVE	SOT-23-THIN	DDC	6	3000	RoHS & Green	SN	Level-1-260C-UNLIM	-40 to 125	STVB	Samples
LM2842YMK-ADJL/NOPB	ACTIVE	SOT-23-THIN	DDC	6	1000	RoHS & Green	SN	Level-1-260C-UNLIM	-40 to 125	STXB	Samples
LM2842YMKX-ADJL/NOPB	ACTIVE	SOT-23-THIN	DDC	6	3000	RoHS & Green	SN	Level-1-260C-UNLIM	-40 to 125	STXB	Samples

(1) The marketing status values are defined as follows:

ACTIVE: Product device recommended for new designs.

LIFEBUY: TI has announced that the device will be discontinued, and a lifetime-buy period is in effect.

NRND: Not recommended for new designs. Device is in production to support existing customers, but TI does not recommend using this part in a new design.

PREVIEW: Device has been announced but is not in production. Samples may or may not be available.

OBSOLETE: TI has discontinued the production of the device.

(2) **RoHS:** TI defines "RoHS" to mean semiconductor products that are compliant with the current EU RoHS requirements for all 10 RoHS substances, including the requirement that RoHS substance do not exceed 0.1% by weight in homogeneous materials. Where designed to be soldered at high temperatures, "RoHS" products are suitable for use in specified lead-free processes. TI may reference these types of products as "Pb-Free".

RoHS Exempt: TI defines "RoHS Exempt" to mean products that contain lead but are compliant with EU RoHS pursuant to a specific EU RoHS exemption.

Green: TI defines "Green" to mean the content of Chlorine (Cl) and Bromine (Br) based flame retardants meet JS709B low halogen requirements of <=1000ppm threshold. Antimony trioxide based flame retardants must also meet the <=1000ppm threshold requirement.

(3) MSL, Peak Temp. - The Moisture Sensitivity Level rating according to the JEDEC industry standard classifications, and peak solder temperature.

(4) There may be additional marking, which relates to the logo, the lot trace code information, or the environmental category on the device.

(5) Multiple Device Markings will be inside parentheses. Only one Device Marking contained in parentheses and separated by a "~" will appear on a device. If a line is indented then it is a continuation of the previous line and the two combined represent the entire Device Marking for that device.

(6) Lead finish/Ball material - Orderable Devices may have multiple material finish options. Finish options are separated by a vertical ruled line. Lead finish/Ball material values may wrap to two lines if the finish value exceeds the maximum column width.

Important Information and Disclaimer:The information provided on this page represents TI's knowledge and belief as of the date that it is provided. TI bases its knowledge and belief on information provided by third parties, and makes no representation or warranty as to the accuracy of such information. Efforts are underway to better integrate information from third parties. TI has taken and continues to take reasonable steps to provide representative and accurate information but may not have conducted destructive testing or chemical analysis on incoming materials and chemicals. TI and TI suppliers consider certain information to be proprietary, and thus CAS numbers and other limited information may not be available for release.

In no event shall TI's liability arising out of such information exceed the total purchase price of the TI part(s) at issue in this document sold by TI to Customer on an annual basis.

TAPE AND REEL INFORMATION

QUADRANT ASSIGNMENTS FOR PIN 1 ORIENTATION IN TAPE

*All dimensions are nominal

Device	Package Type	Package Drawing	Pins	SPQ	Reel Diameter (mm)	Reel Width W1 (mm)	A0 (mm)	B0 (mm)	K0 (mm)	P1 (mm)	W (mm)	Pin1 Quadrant
LM2840XMK-ADJL/NOPB	SOT-23-THIN	DDC	6	1000	178.0	8.4	3.2	3.2	1.4	4.0	8.0	Q3
LM2840XMKX-ADJL/NOPB	SOT-23-THIN	DDC	6	3000	178.0	8.4	3.2	3.2	1.4	4.0	8.0	Q3
LM2840YMK-ADJL/NOPB	SOT-23-THIN	DDC	6	1000	178.0	8.4	3.2	3.2	1.4	4.0	8.0	Q3
LM2841XMK-ADJL/NOPB	SOT-23-THIN	DDC	6	1000	178.0	8.4	3.2	3.2	1.4	4.0	8.0	Q3
LM2841XMKX-ADJL/NOPB	SOT-23-THIN	DDC	6	3000	178.0	8.4	3.2	3.2	1.4	4.0	8.0	Q3
LM2841YMK-ADJL/NOPB	SOT-23-THIN	DDC	6	1000	178.0	8.4	3.2	3.2	1.4	4.0	8.0	Q3
LM2841YMKX-ADJL/NOPB	SOT-23-THIN	DDC	6	3000	178.0	8.4	3.2	3.2	1.4	4.0	8.0	Q3
LM2842XMK-ADJL/NOPB	SOT-23-THIN	DDC	6	1000	178.0	8.4	3.2	3.2	1.4	4.0	8.0	Q3
LM2842XMKX-ADJL/NOPB	SOT-23-THIN	DDC	6	3000	178.0	8.4	3.2	3.2	1.4	4.0	8.0	Q3

Device	Package Type	Package Drawing	Pins	SPQ	Reel Diameter (mm)	Reel Width W1 (mm)	A0 (mm)	B0 (mm)	K0 (mm)	P1 (mm)	W (mm)	Pin1 Quadrant
LM2842YMK-ADJL/NOPB	SOT-23-THIN	DDC	6	1000	178.0	8.4	3.2	3.2	1.4	4.0	8.0	Q3
LM2842YMKX-ADJL/NOPB	SOT-23-THIN	DDC	6	3000	178.0	8.4	3.2	3.2	1.4	4.0	8.0	Q3

TAPE AND REEL BOX DIMENSIONS

*All dimensions are nominal

Device	Package Type	Package Drawing	Pins	SPQ	Length (mm)	Width (mm)	Height (mm)
LM2840XMK-ADJL/NOPB	SOT-23-THIN	DDC	6	1000	210.0	185.0	35.0
LM2840XMKX-ADJL/NOPB	SOT-23-THIN	DDC	6	3000	210.0	185.0	35.0
LM2840YMK-ADJL/NOPB	SOT-23-THIN	DDC	6	1000	210.0	185.0	35.0
LM2841XMK-ADJL/NOPB	SOT-23-THIN	DDC	6	1000	210.0	185.0	35.0
LM2841XMKX-ADJL/NOPB	SOT-23-THIN	DDC	6	3000	210.0	185.0	35.0
LM2841YMK-ADJL/NOPB	SOT-23-THIN	DDC	6	1000	210.0	185.0	35.0
LM2841YMKX-ADJL/NOPB	SOT-23-THIN	DDC	6	3000	208.0	191.0	35.0
LM2842XMK-ADJL/NOPB	SOT-23-THIN	DDC	6	1000	208.0	191.0	35.0
LM2842XMKX-ADJL/NOPB	SOT-23-THIN	DDC	6	3000	208.0	191.0	35.0
LM2842YMK-ADJL/NOPB	SOT-23-THIN	DDC	6	1000	208.0	191.0	35.0
LM2842YMKX-ADJL/NOPB	SOT-23-THIN	DDC	6	3000	208.0	191.0	35.0

EXAMPLE BOARD LAYOUT

DDC0006A

SOT-23 - 1.1 max height

SMALL OUTLINE TRANSISTOR

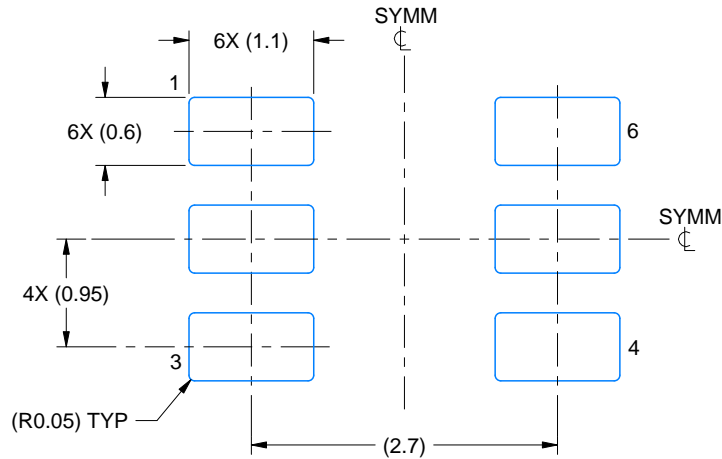

LAND PATTERN EXAMPLE
EXPLODED METAL SHOWN
SCALE:15X



SOLDEMASK DETAILS

4214841/E 08/2024

NOTES: (continued)

- 4. Publication IPC-7351 may have alternate designs.
- 5. Solder mask tolerances between and around signal pads can vary based on board fabrication site.

EXAMPLE STENCIL DESIGN

DDC0006A

SOT-23 - 1.1 max height

SMALL OUTLINE TRANSISTOR

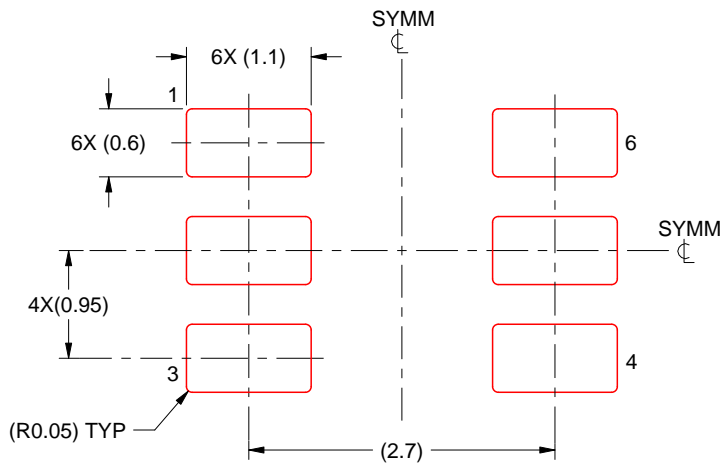

SOLDER PASTE EXAMPLE
BASED ON 0.125 THICK STENCIL
SCALE:15X

4214841/E 08/2024

NOTES: (continued)

6. Laser cutting apertures with trapezoidal walls and rounded corners may offer better paste release. IPC-7525 may have alternate design recommendations.
7. Board assembly site may have different recommendations for stencil design.

重要なお知らせと免責事項

TI は、技術データと信頼性データ (データシートを含みます)、設計リソース (リファレンス・デザインを含みます)、アプリケーションや設計に関する各種アドバイス、Web ツール、安全性情報、その他のリソースを、欠陥が存在する可能性のある「現状のまま」提供しており、商品性および特定目的に対する適合性の黙示保証、第三者の知的財産権の非侵害保証を含むいかなる保証も、明示的または黙示的にかかわらず拒否します。

これらのリソースは、TI 製品を使用する設計の経験を積んだ開発者への提供を意図したものです。(1) お客様のアプリケーションに適した TI 製品の選定、(2) お客様のアプリケーションの設計、検証、試験、(3) お客様のアプリケーションに該当する各種規格や、その他のあらゆる安全性、セキュリティ、規制、または他の要件への確実な適合に関する責任を、お客様のみが単独で負うものとし、

上記の各種リソースは、予告なく変更される可能性があります。これらのリソースは、リソースで説明されている TI 製品を使用するアプリケーションの開発の目的でのみ、TI はその使用をお客様に許諾します。これらのリソースに関して、他の目的で複製することや掲載することは禁止されています。TI や第三者の知的財産権のライセンスが付与されている訳ではありません。お客様は、これらのリソースを自身で使用した結果発生するあらゆる申し立て、損害、費用、損失、責任について、TI およびその代理人を完全に補償するものとし、TI は一切の責任を拒否します。

TI の製品は、[TI の販売条件](#)、または [ti.com](#) やかかる TI 製品の関連資料などのいずれかを通じて提供する適用可能な条項の下で提供されています。TI がこれらのリソースを提供することは、適用される TI の保証または他の保証の放棄の拡大や変更を意味するものではありません。

お客様がいかなる追加条項または代替条項を提案した場合でも、TI はそれらに異議を唱え、拒否します。

郵送先住所 : Texas Instruments, Post Office Box 655303, Dallas, Texas 75265
Copyright © 2024, Texas Instruments Incorporated