

LM741-MIL オペアンプ

1 特長

- 入力および出力の過負荷保護
- 同相範囲の超過時にラッチアップなし

2 アプリケーション

- コンパレータ
- マルチバイブレータ
- DCアンプ
- 加算アンプ
- 積分器または微分器
- アクティブ・フィルタ

3 概要

LM741-MILは汎用オペアンプで、LM709など業界標準の製品と比べて性能が向上しています。ほとんどのアプリケーションにおいて、709C、LM201、MC1439、748の直接プラグイン代替品として使用できます。

このアンプには、入力と出力の過負荷保護、同相範囲を超過したときにラッチアップが発生しない、発振の影響を受けないなど多くの特長があり、アプリケーションの誤使用をほぼ完全に防止できます。

製品情報⁽¹⁾

型番	パッケージ	本体サイズ(公称)
LM741-MIL	TO-99 (8)	9.08mm×9.08mm
	CDIP (8)	10.16mm×6.502mm
	PDIP (8)	9.81mm×6.35mm

(1) 利用可能なすべてのパッケージについては、このデータシートの末尾にある注文情報を参照してください。

アプリケーション概略図

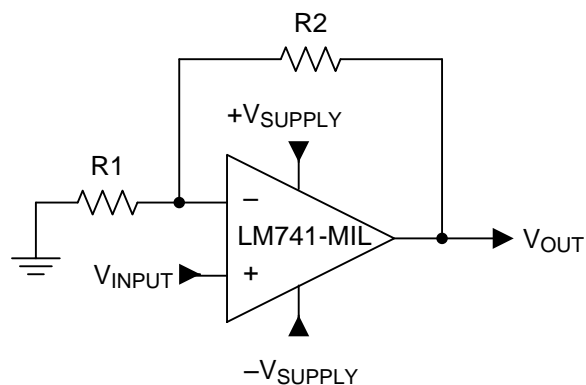

Copyright © 2017, Texas Instruments Incorporated

目次

1	特長	1	7.4	Device Functional Modes	7
2	アプリケーション	1	8	Application and Implementation	8
3	概要	1	8.1	Application Information	8
4	改訂履歴	2	8.2	Typical Application	8
5	Pin Configuration and Functions	3	9	Power Supply Recommendations	9
6	Specifications	4	10	Layout	9
6.1	Absolute Maximum Ratings	4	10.1	Layout Guidelines	9
6.2	ESD Ratings	4	10.2	Layout Example	9
6.3	Recommended Operating Conditions	4	11	デバイスおよびドキュメントのサポート	10
6.4	Thermal Information	4	11.1	ドキュメントの更新通知を受け取る方法	10
6.5	Electrical Characteristics	5	11.2	コミュニティ・リソース	10
7	Detailed Description	6	11.3	商標	10
7.1	Overview	6	11.4	静電気放電に関する注意事項	10
7.2	Functional Block Diagram	6	11.5	Glossary	10
7.3	Feature Description	6	12	メカニカル、パッケージ、および注文情報	10

4 改訂履歴

資料番号末尾の英字は改訂を表しています。その改訂履歴は英語版に準じています。

日付	改訂内容	注
2017年6月	*	初版

5 Pin Configuration and Functions

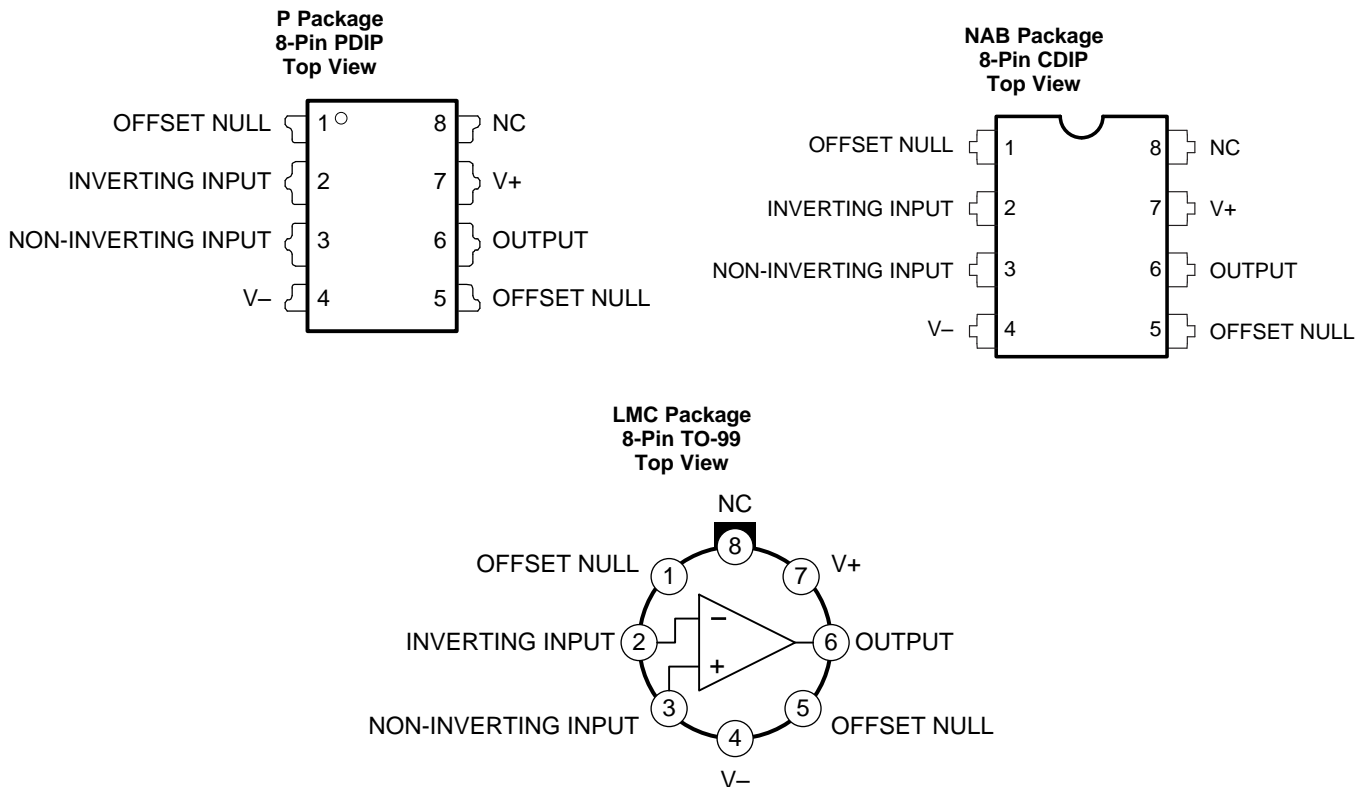

Pin Functions

PIN		I/O	DESCRIPTION
NAME	NO.		
INVERTING INPUT	2	I	Inverting signal input
NC	8	N/A	No Connect, leave floating
NONINVERTING INPUT	3	I	Noninverting signal input
OFFSET NULL	1	I	Offset null pin used to eliminate the offset voltage and balance the input voltages.
OFFSET NULL	5		
OUTPUT	6	O	Amplified signal output
V+	7	I	Positive supply voltage
V-	4	I	Negative supply voltage

6 Specifications

6.1 Absolute Maximum Ratings

 over operating free-air temperature range (unless otherwise noted)⁽¹⁾⁽²⁾⁽³⁾

	MIN	MAX	UNIT
Supply voltage		±22	V
Power dissipation ⁽⁴⁾		500	mW
Differential input voltage		±30	V
Input voltage ⁽⁵⁾		±15	V
Output short circuit duration		Continuous	
Operating temperature	–50	125	°C
Junction temperature, $T_{J(max)}$		150	°C
Storage temperature, T_{stg}	–65	150	°C

- (1) Stresses beyond those listed under *Absolute Maximum Ratings* may cause permanent damage to the device. These are stress ratings only, which do not imply functional operation of the device at these or any other conditions beyond those specified in the *Recommended Operating Conditions* table. Exposure to absolute-maximum-rated conditions for extended periods may affect device reliability.
- (2) For military specifications see RETS741X for LM741-MIL and RETS741AX for LM741-MILA.
- (3) If Military/Aerospace specified devices are required, please contact the TI Sales Office/Distributors for availability and specifications.
- (4) For operation at elevated temperatures, these devices must be derated based on thermal resistance, and $T_{J(max)}$. (listed in the *Absolute Maximum Ratings* table). $T_j = T_A + (\theta_{JA} \times P_D)$.
- (5) For supply voltages less than ±15 V, the absolute maximum input voltage is equal to the supply voltage.

6.2 ESD Ratings

	VALUE	UNIT
$V_{(ESD)}$ Electrostatic discharge Human body model (HBM), per ANSI/ESDA/JEDEC JS-001 ⁽¹⁾	±400	V

- (1) Level listed above is the passing level per ANSI, ESDA, and JEDEC JS-001. JEDEC document JEP155 states that 500-V HBM allows safe manufacturing with a standard ESD control process.

6.3 Recommended Operating Conditions

over operating free-air temperature range (unless otherwise noted)

	MIN	NOM	MAX	UNIT
Supply voltage (VDD-GND)	±10	±15	±22	V
Temperature	–55		125	°C

6.4 Thermal Information

THERMAL METRIC ⁽¹⁾	LM741-MIL			UNIT
	LMC (TO-99)	NAB (CDIP)	P (PDIP)	
	8 PINS	8 PINS	8 PINS	
$R_{\theta JA}$ Junction-to-ambient thermal resistance	170	100	100	°C/W
$R_{\theta JC(top)}$ Junction-to-case (top) thermal resistance	25	—	—	°C/W

- (1) For more information about traditional and new thermal metrics, see the *Semiconductor and IC Package Thermal Metrics* application report, [SPRA953](#).

6.5 Electrical Characteristics

 $V_S = \pm 15\text{ V}$, $-55^\circ\text{C} \leq T_A \leq 125^\circ\text{C}$ (unless otherwise specified)

PARAMETER		TEST CONDITIONS	MIN	TYP	MAX	UNIT
Input offset voltage	$R_S \leq 10\text{ k}\Omega$	$T_A = 25^\circ\text{C}$		1	5	mV
					6	mV
Input offset voltage adjustment range	$T_A = 25^\circ\text{C}$, $V_S = \pm 20\text{ V}$			± 15		mV
Input offset current	$T_A = 25^\circ\text{C}$			20	200	nA
				85	500	
Input bias current	$T_A = 25^\circ\text{C}$			80	500	nA
					1.5	μA
Input resistance	$T_A = 25^\circ\text{C}$, $V_S = \pm 20\text{ V}$		0.3	2		M Ω
Input voltage range			± 12	± 13		V
Large signal voltage gain	$V_S = \pm 15\text{ V}$, $V_O = \pm 10\text{ V}$, $R_L \geq 2\text{ k}\Omega$	$T_A = 25^\circ\text{C}$	50	200		V/mV
			25			
Output voltage swing	$V_S = \pm 15\text{ V}$	$R_L \geq 10\text{ k}\Omega$	± 12	± 14		V
		$R_L \geq 2\text{ k}\Omega$	± 10	± 13		
Output short circuit current	$T_A = 25^\circ\text{C}$			25		mA
Common-mode rejection ratio	$R_S \leq 10\ \Omega$, $V_{CM} = \pm 12\text{ V}$		80	95		dB
Supply voltage rejection ratio	$V_S = \pm 20\text{ V}$ to $V_S = \pm 5\text{ V}$, $R_S \leq 10\ \Omega$		86	96		dB
Transient response	Rise time	$T_A = 25^\circ\text{C}$, unity gain		0.3		μs
	Overshoot			5%		
Slew rate	$T_A = 25^\circ\text{C}$, unity gain			0.5		V/ μs
Supply current	$T_A = 25^\circ\text{C}$			1.7	2.8	mA
Power consumption	$V_S = \pm 15\text{ V}$	$T_A = 25^\circ\text{C}$		50	85	mW
		$T_A = T_{A(\text{min})}$		60	100	
		$T_A = T_{A(\text{min})}$		45	75	

7 Detailed Description

7.1 Overview

The LM741-MIL device is a general-purpose operational amplifier which features improved performance over industry standards such as the LM709. It is intended for a wide range of analog applications. The high gain and wide range of operating voltage provide superior performance in integrator, summing amplifier, and general feedback applications. The LM741-MIL operates with either a single or dual power supply voltage. The LM741-MIL device is a direct, plug-in replacement for the 709C, LM201, MC1439, and 748 in most applications.

7.2 Functional Block Diagram

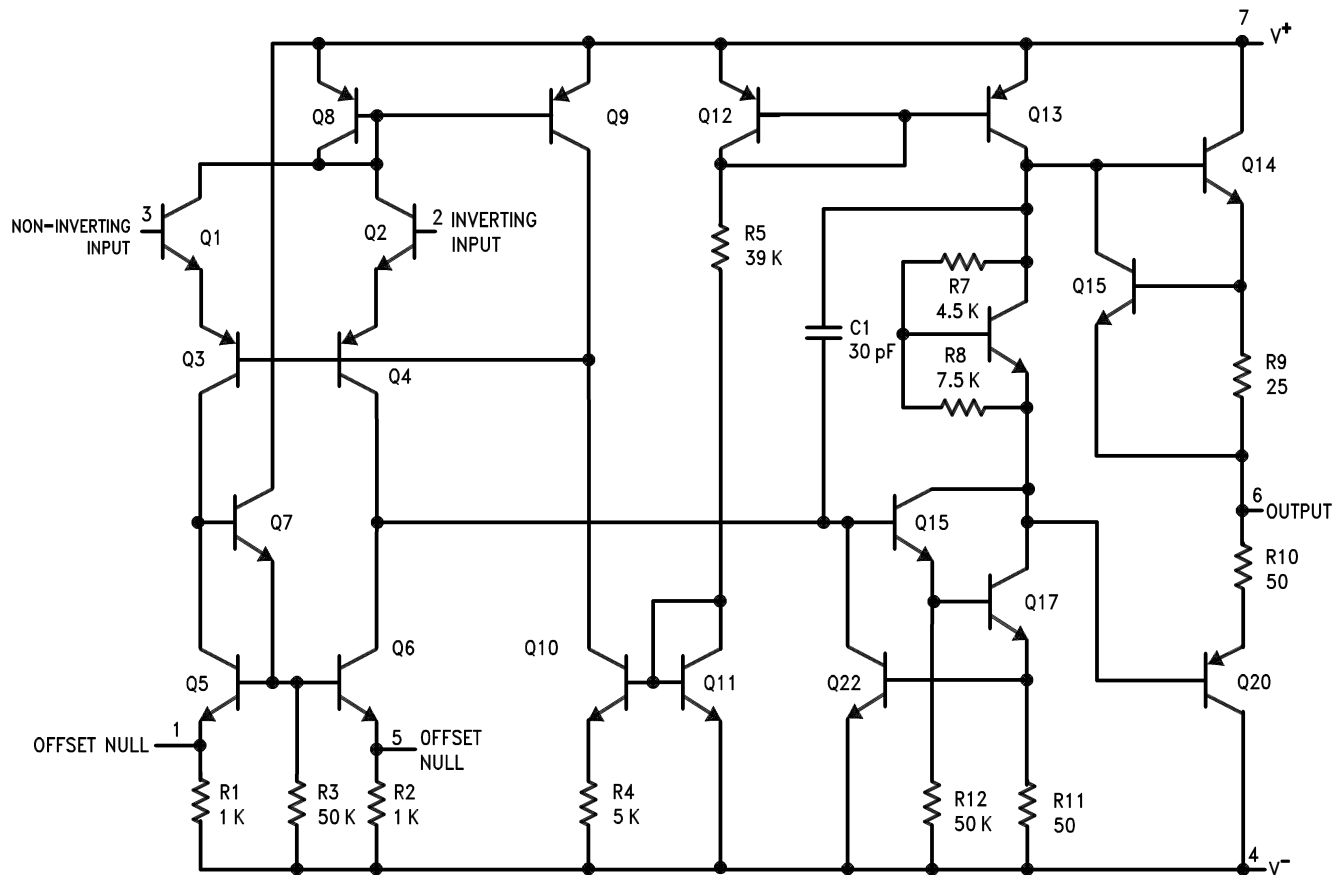

7.3 Feature Description

7.3.1 Overload Protection

The LM741-MIL features overload protection circuitry on the input and output. This prevents possible circuit damage to the device.

7.3.2 Latch-up Prevention

The LM741-MIL is designed so that there is no latch-up occurrence when the common-mode range is exceeded. This allows the device to function properly without having to power cycle the device.

7.3.3 Pin-to-Pin Capability

The LM741-MIL is a pin-to-pin direct replacement for the LM709C, LM201, MC1439, and LM748 in most applications. Direct replacement capabilities allows flexibility in design for replacing obsolete parts.

7.4 Device Functional Modes

7.4.1 Open-Loop Amplifier

The LM741-MIL can be operated in an open-loop configuration. The magnitude of the open-loop gain is typically large thus for a small difference between the non-inverting input terminals and the inverting input terminals, the amplifier output is driven near the supply voltage. Without negative feedback, the LM741-MIL can act as a comparator. If the inverting input is held at 0 V, and the input voltage applied to the non-inverting input is positive, the output will be positive. If the input voltage applied to the non-inverting input is negative, the output is negative.

7.4.2 Closed-Loop Amplifier

In a closed-loop configuration, negative feedback is used by applying a portion of the output voltage to the inverting input. Unlike the open-loop configuration, closed loop feedback reduces the gain of the circuit. The overall gain and response of the circuit is determined by the feedback network rather than the operational amplifier characteristics. The response of the operational amplifier circuit is characterized by the transfer function.

8 Application and Implementation

NOTE

Information in the following applications sections is not part of the TI component specification, and TI does not warrant its accuracy or completeness. TI's customers are responsible for determining suitability of components for their purposes. Customers should validate and test their design implementation to confirm system functionality.

8.1 Application Information

The LM741-MIL is a general-purpose amplifier that can be used in a variety of applications and configurations. One common configuration is in a non-inverting amplifier configuration. In this configuration, the output signal is in phase with the input (not inverted as in the inverting amplifier configuration), the input impedance of the amplifier is high, and the output impedance is low. The characteristics of the input and output impedance is beneficial for applications that require isolation between the input and output. No significant loading will occur from the previous stage before the amplifier. The gain of the system is set accordingly so the output signal is a factor larger than the input signal.

8.2 Typical Application

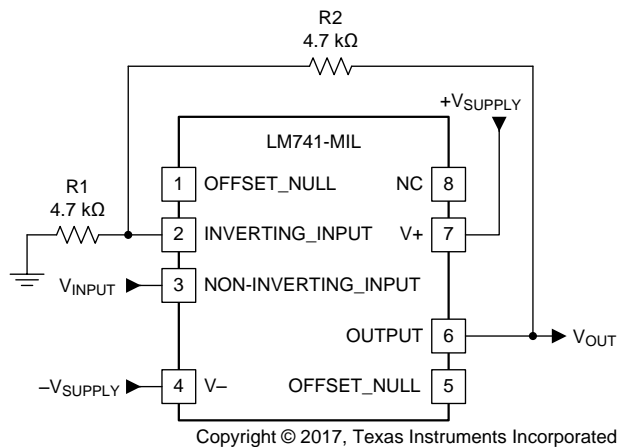

Figure 1. LM741-MIL Noninverting Amplifier Circuit

8.2.1 Design Requirements

As shown in [Figure 1](#), the signal is applied to the noninverting input of the LM741-MIL. The gain of the system is determined by the feedback resistor and input resistor connected to the inverting input. The gain can be calculated by [Equation 1](#):

$$\text{Gain} = 1 + (R2/R1) \quad (1)$$

The gain is set to 2 for this application. R1 and R2 are 4.7-kΩ resistors with 5% tolerance.

8.2.2 Detailed Design Procedure

The LM741-MIL can be operated in either single supply or dual supply. This application is configured for dual supply with the supply rails at ± 15 V. The input signal is connected to a function generator. A 1- V_{pp} , 10-kHz sine wave was used as the signal input. 5% tolerance resistors were used, but if the application requires an accurate gain response, use 1% tolerance resistors.

8.2.3 Application Curve

The waveforms in [Figure 2](#) show the input and output signals of the LM741-MIL non-inverting amplifier circuit. The blue waveform (top) shows the input signal, while the red waveform (bottom) shows the output signal. The input signal is 1.06 V_{p-p} and the output signal is 1.94 V_{p-p} . With the 4.7-kΩ resistors, the theoretical gain of the system is 2. Due to the 5% tolerance, the gain of the system including the tolerance is 1.992. The gain of the system when measured from the mean amplitude values on the oscilloscope was 1.83.

Typical Application (continued)

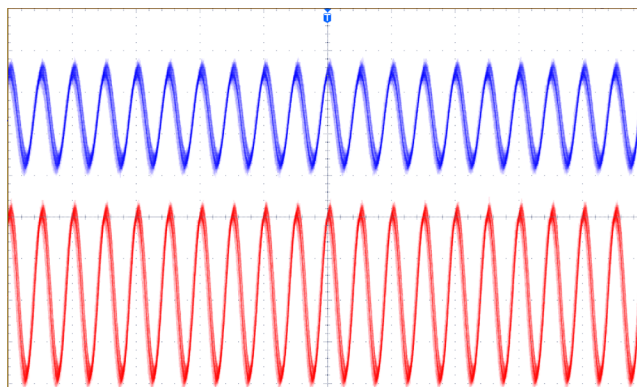

Figure 2. Waveforms for LM741-MIL Non-inverting Amplifier Circuit

9 Power Supply Recommendations

For proper operation, the power supplies must be properly decoupled. For decoupling the supply lines, a 0.1- μ F capacitor is recommended and should be placed as close as possible to the LM741-MIL power supply pins.

10 Layout

10.1 Layout Guidelines

As with most amplifiers, take care with lead dress, component placement, and supply decoupling in order to ensure stability. For example, resistors from the output to an input should be placed with the body close to the input to minimize pick-up and maximize the frequency of the feedback pole by minimizing the capacitance from the input to ground. As shown in Figure 3, the feedback resistors and the decoupling capacitors are located close to the device to ensure maximum stability and noise performance of the system.

10.2 Layout Example

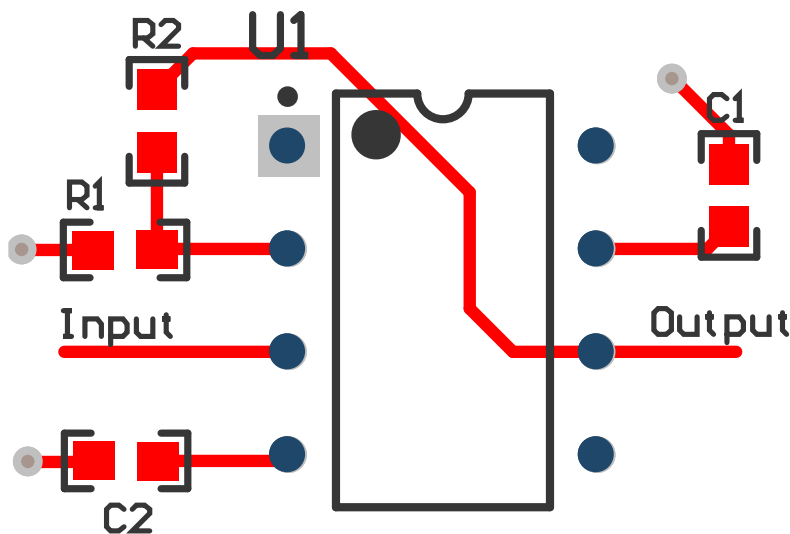

Figure 3. LM741-MIL Layout

11 デバイスおよびドキュメントのサポート

11.1 ドキュメントの更新通知を受け取る方法

ドキュメントの更新についての通知を受け取るには、ti.comのデバイス製品フォルダを開いてください。右上の隅にある「通知を受け取る」をクリックして登録すると、変更されたすべての製品情報に関するダイジェストを毎週受け取れます。変更の詳細については、修正されたドキュメントに含まれている改訂履歴をご覧ください。

11.2 コミュニティ・リソース

The following links connect to TI community resources. Linked contents are provided "AS IS" by the respective contributors. They do not constitute TI specifications and do not necessarily reflect TI's views; see TI's [Terms of Use](#).

TI E2E™オンライン・コミュニティ *TIのE2E (Engineer-to-Engineer) コミュニティ*。エンジニア間の共同作業を促進するために開設されたものです。e2e.ti.comでは、他のエンジニアに質問し、知識を共有し、アイデアを検討して、問題解決に役立てることができます。

設計サポート *TIの設計サポート* 役に立つE2Eフォーラムや、設計サポート・ツールをすばやく見つけることができます。技術サポート用の連絡先情報も参照できます。

11.3 商標

E2E is a trademark of Texas Instruments.
All other trademarks are the property of their respective owners.

11.4 静電気放電に関する注意事項



これらのデバイスは、限定的なESD(静電破壊)保護機能を内蔵しています。保存時または取り扱い時は、MOSゲートに対する静電破壊を防止するために、リード線同士をショートさせておくか、デバイスを導電フォームに入れる必要があります。

11.5 Glossary

[SLYZ022](#) — *TI Glossary*.

This glossary lists and explains terms, acronyms, and definitions.

12 メカニカル、パッケージ、および注文情報

以降のページには、メカニカル、パッケージ、および注文に関する情報が記載されています。この情報は、そのデバイスについて利用可能な最新のデータです。このデータは予告なく変更されることがあり、ドキュメントが改訂される場合もあります。本データシートのブラウザ版を使用されている場合は、画面左側の説明をご覧ください。

PACKAGING INFORMATION

Orderable Device	Status (1)	Package Type	Package Drawing	Pins	Package Qty	Eco Plan (2)	Lead finish/ Ball material (6)	MSL Peak Temp (3)	Op Temp (°C)	Device Marking (4/5)	Samples
LM741CH	ACTIVE	TO-99	LMC	8	500	Non-RoHS & Green	Call TI	Level-1-NA-UNLIM	0 to 70	(LM741CH, LM741CH)	Samples
LM741CH/NOPB	ACTIVE	TO-99	LMC	8	500	RoHS & Green	Call TI	Level-1-NA-UNLIM	0 to 70	(LM741CH, LM741CH)	Samples
LM741H	ACTIVE	TO-99	LMC	8	500	Non-RoHS & Green	Call TI	Level-1-NA-UNLIM	-55 to 125	(LM741H, LM741H)	Samples
LM741H/NOPB	ACTIVE	TO-99	LMC	8	500	RoHS & Green	Call TI	Level-1-NA-UNLIM	-55 to 125	(LM741H, LM741H)	Samples
LM741J	ACTIVE	CDIP	NAB	8	40	Non-RoHS & Green	Call TI	Level-1-NA-UNLIM	-55 to 125	LM741J	Samples
U5B7741312	ACTIVE	TO-99	LMC	8	500	Non-RoHS & Green	Call TI	Level-1-NA-UNLIM	-55 to 125	(LM741H, LM741H)	Samples
U5B7741393	ACTIVE	TO-99	LMC	8	500	Non-RoHS & Green	Call TI	Level-1-NA-UNLIM	0 to 70	(LM741CH, LM741CH)	Samples

(1) The marketing status values are defined as follows:

ACTIVE: Product device recommended for new designs.

LIFEBUY: TI has announced that the device will be discontinued, and a lifetime-buy period is in effect.

NRND: Not recommended for new designs. Device is in production to support existing customers, but TI does not recommend using this part in a new design.

PREVIEW: Device has been announced but is not in production. Samples may or may not be available.

OBSOLETE: TI has discontinued the production of the device.

(2) **RoHS:** TI defines "RoHS" to mean semiconductor products that are compliant with the current EU RoHS requirements for all 10 RoHS substances, including the requirement that RoHS substance do not exceed 0.1% by weight in homogeneous materials. Where designed to be soldered at high temperatures, "RoHS" products are suitable for use in specified lead-free processes. TI may reference these types of products as "Pb-Free".

RoHS Exempt: TI defines "RoHS Exempt" to mean products that contain lead but are compliant with EU RoHS pursuant to a specific EU RoHS exemption.

Green: TI defines "Green" to mean the content of Chlorine (Cl) and Bromine (Br) based flame retardants meet JS709B low halogen requirements of <=1000ppm threshold. Antimony trioxide based flame retardants must also meet the <=1000ppm threshold requirement.

(3) MSL, Peak Temp. - The Moisture Sensitivity Level rating according to the JEDEC industry standard classifications, and peak solder temperature.

(4) There may be additional marking, which relates to the logo, the lot trace code information, or the environmental category on the device.

(5) Multiple Device Markings will be inside parentheses. Only one Device Marking contained in parentheses and separated by a "~" will appear on a device. If a line is indented then it is a continuation of the previous line and the two combined represent the entire Device Marking for that device.

⁽⁶⁾ Lead finish/Ball material - Orderable Devices may have multiple material finish options. Finish options are separated by a vertical ruled line. Lead finish/Ball material values may wrap to two lines if the finish value exceeds the maximum column width.

Important Information and Disclaimer: The information provided on this page represents TI's knowledge and belief as of the date that it is provided. TI bases its knowledge and belief on information provided by third parties, and makes no representation or warranty as to the accuracy of such information. Efforts are underway to better integrate information from third parties. TI has taken and continues to take reasonable steps to provide representative and accurate information but may not have conducted destructive testing or chemical analysis on incoming materials and chemicals. TI and TI suppliers consider certain information to be proprietary, and thus CAS numbers and other limited information may not be available for release.

In no event shall TI's liability arising out of such information exceed the total purchase price of the TI part(s) at issue in this document sold by TI to Customer on an annual basis.

NAB0008A

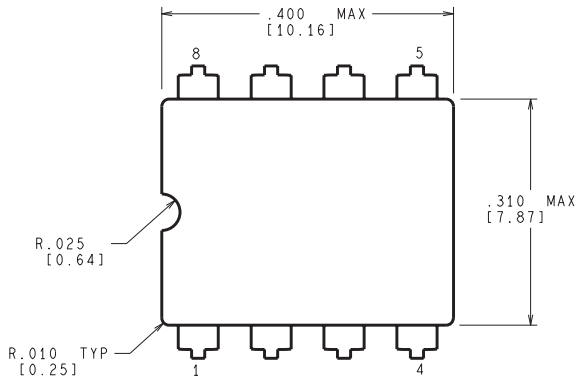

CONTROLLING DIMENSION IS INCH
VALUES IN [] ARE MILLIMETERS

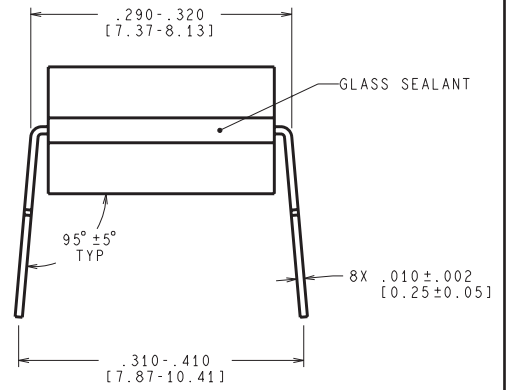
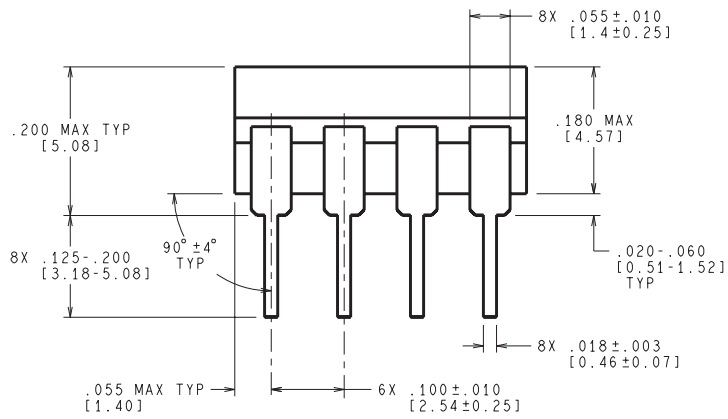

J08A (Rev M)

PACKAGE OUTLINE

LMC0008A

TO-CAN - 5.72 mm max height

TRANSISTOR OUTLINE

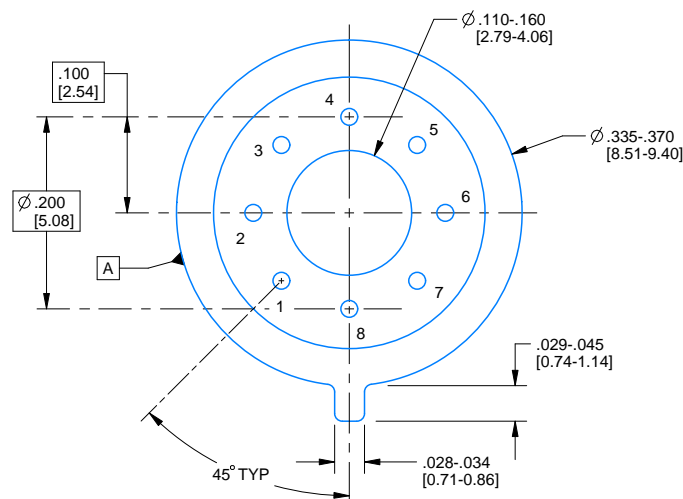
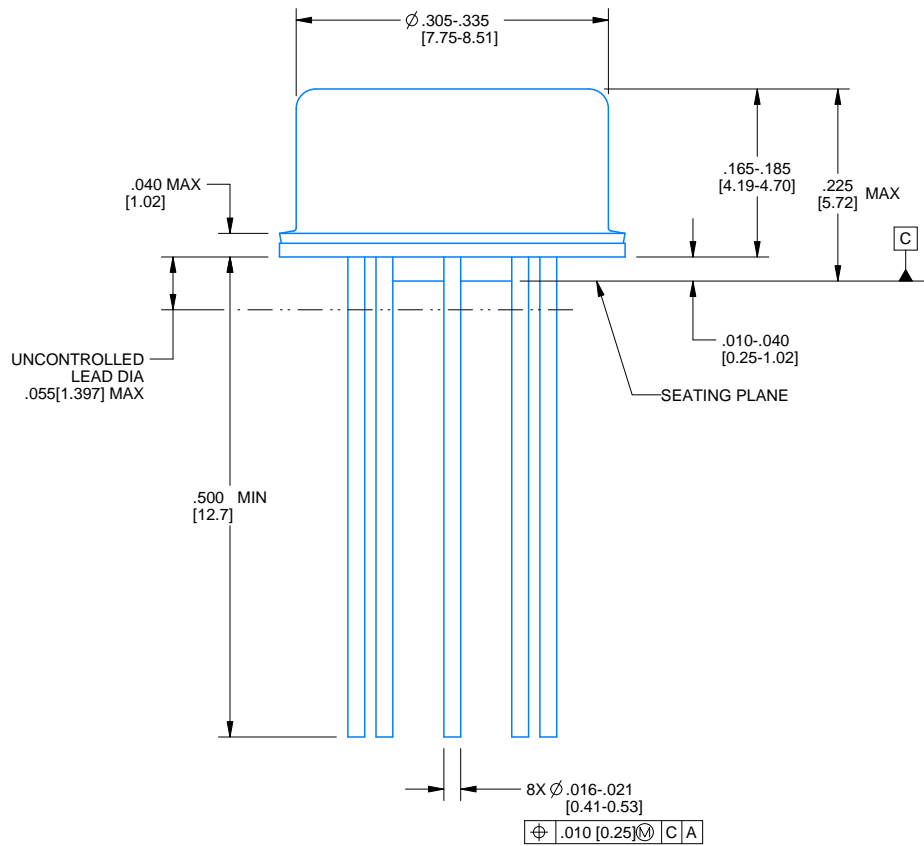

4220610/B 09/2024

NOTES:

1. All linear dimensions are in inches [millimeters]. Any dimensions in parenthesis are for reference only. Dimensioning and tolerancing per ASME Y14.5M.
2. This drawing is subject to change without notice.
3. Pin numbers shown for reference only. Numbers may not be marked on package.
4. Reference JEDEC registration MO-002/TO-99.

EXAMPLE BOARD LAYOUT

LMC0008A

TO-CAN - 5.72 mm max height

TRANSISTOR OUTLINE

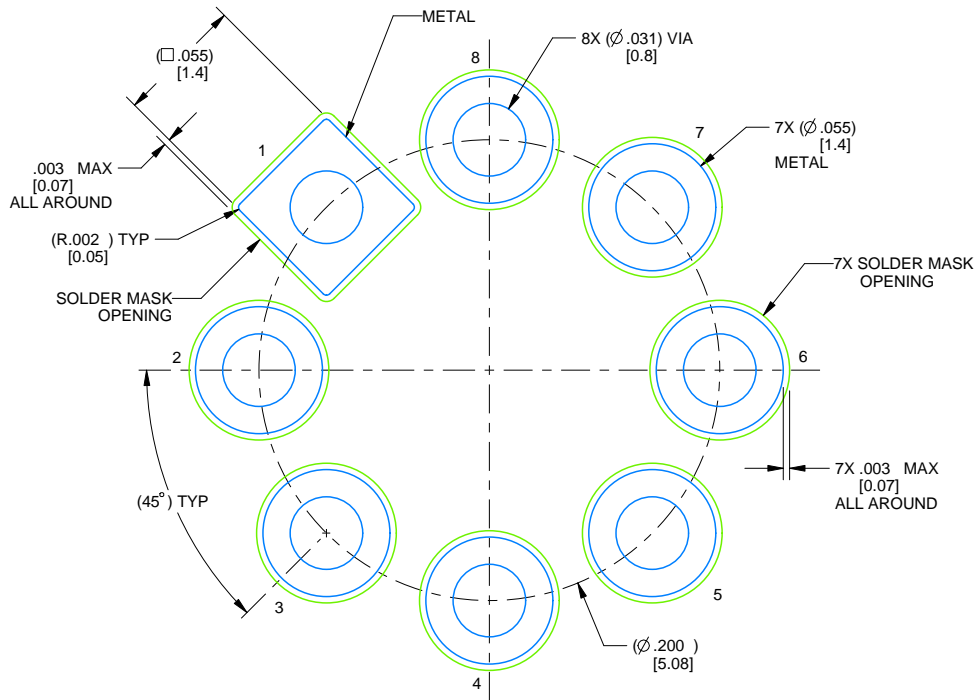

LAND PATTERN EXAMPLE
NON-SOLDER MASK DEFINED
SCALE: 12X

4220610/B 09/2024

重要なお知らせと免責事項

TI は、技術データと信頼性データ（データシートを含みます）、設計リソース（リファレンス・デザインを含みます）、アプリケーションや設計に関する各種アドバイス、Web ツール、安全性情報、その他のリソースを、欠陥が存在する可能性のある「現状のまま」提供しており、商品性および特定目的に対する適合性の黙示保証、第三者の知的財産権の非侵害保証を含むいかなる保証も、明示的または黙示的にかかわらず拒否します。

これらのリソースは、TI 製品を使用する設計の経験を積んだ開発者への提供を意図したものです。(1) お客様のアプリケーションに適した TI 製品の選定、(2) お客様のアプリケーションの設計、検証、試験、(3) お客様のアプリケーションに該当する各種規格や、その他のあらゆる安全性、セキュリティ、規制、または他の要件への確実な適合に関する責任を、お客様のみが単独で負うものとし、

上記の各種リソースは、予告なく変更される可能性があります。これらのリソースは、リソースで説明されている TI 製品を使用するアプリケーションの開発の目的でのみ、TI はその使用をお客様に許諾します。これらのリソースに関して、他の目的で複製することや掲載することは禁止されています。TI や第三者の知的財産権のライセンスが付与されている訳ではありません。お客様は、これらのリソースを自身で使用した結果発生するあらゆる申し立て、損害、費用、損失、責任について、TI およびその代理人を完全に補償するものとし、TI は一切の責任を拒否します。

TI の製品は、[TI の販売条件](#)、または [ti.com](#) やかかる TI 製品の関連資料などのいずれかを通じて提供する適用可能な条項の下で提供されています。TI がこれらのリソースを提供することは、適用される TI の保証または他の保証の放棄の拡大や変更を意味するものではありません。

お客様がいかなる追加条項または代替条項を提案した場合でも、TI はそれらに異議を唱え、拒否します。

郵送先住所：Texas Instruments, Post Office Box 655303, Dallas, Texas 75265
Copyright © 2024, Texas Instruments Incorporated