

LMG1025-Q1 Automotive Low Side GaN and MOSFET Driver For High Frequency and Narrow Pulse Applications

1 Features

- AEC-Q100 grade 1 qualified
- 1.25-ns typical minimum input pulse width
- 2.6-ns typical rising propagation delay
- 2.9-ns typical falling propagation delay
- 300-ps typical pulse distortion
- Independent 7-A pull-up and 5-A pull-down current
- 650-ps typical rise time (220-pF load)
- 850-ps typical fall time (220-pF load)
- 2-mm x 2-mm QFN package
- Inverting and non-inverting inputs
- UVLO and over-temperature protection
- Single 5-V supply voltage

2 Applications

- [Automotive LIDAR](#)
- [Driver Monitoring](#)
- [Vehicle Occupant Detection Sensor](#)
- [DC/DC Converter](#)

3 Description

The LMG1025-Q1 is a single channel low-side enhancement-mode GaN FET and logic-level MOSFET driver for high switching frequency automotive applications. Narrow pulse width capability, fast switching specification, and small pulse distortion combine to significantly enhance LiDAR, ToF, and Power Converter performance. 1.25-ns output pulse width enables more powerful, eye-safe diode pulses. This, combined with 300-ns distortion, leads to longer-range, precise LiDAR/ToF systems. 2.9-ns propagation delay significantly improves the control loop response time and thus overall performance of the power converters. Split output allows the drive strength and timing to be independently adjusted through external resistors between OUTH, OUTL, and the FET gate.

The driver features undervoltage lockout (UVLO) and over-temperature protection (OTP) to ensure the device is not damaged in overload or fault conditions. LMG1025-Q1 is available in a compact, leadless, AEC-Q100 automotive qualified package to meet the size and gate loop inductance requirements of high switching frequency automotive applications.

Device Information⁽¹⁾

PART NUMBER	PACKAGE	BODY SIZE (NOM) (mm)
LMG1025-Q1	WSON(6)	2-mm x 2-mm

(1) For all available packages, see the orderable addendum at the end of the data sheet.

Typical (Simplified) System Diagram

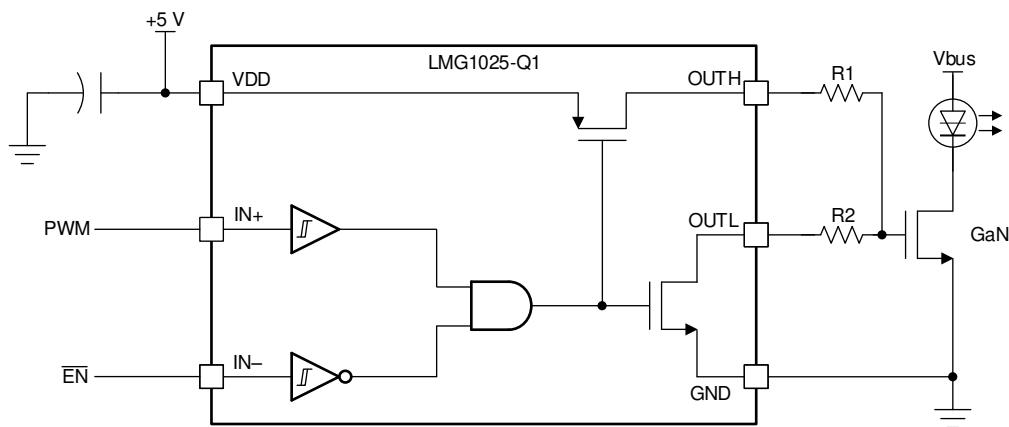

Table of Contents

1 Features	1	7.3 Feature Description.....	7
2 Applications	1	7.4 Device Functional Modes.....	8
3 Description	1	8 Application and Implementation	9
4 Revision History	2	8.1 Application Information.....	9
5 Pin Configuration and Functions	3	8.2 Typical Application	9
6 Specifications	4	9 Power Supply Recommendations	15
6.1 Absolute Maximum Ratings	4	10 Layout	16
6.2 ESD Ratings.....	4	10.1 Layout Guidelines	16
6.3 Recommended Operating Conditions.....	4	10.2 Layout Example	16
6.4 Thermal Information	4	11 Device and Documentation Support	17
6.5 Electrical Characteristics.....	5	11.1 Receiving Notification of Documentation Updates	17
6.6 Switching Characteristics	5	11.2 Support Resources	17
6.7 Typical Characteristics	6	11.3 Trademarks	17
7 Detailed Description	7	11.4 Electrostatic Discharge Caution.....	17
7.1 Overview	7	11.5 Glossary	17
7.2 Functional Block Diagram	7	12 Mechanical, Packaging, and Orderable Information	17

4 Revision History

Changes from Revision A (August 2019) to Revision B

Page

• Changed marketing status from Advance Information to Production Data	1
--	----------

5 Pin Configuration and Functions

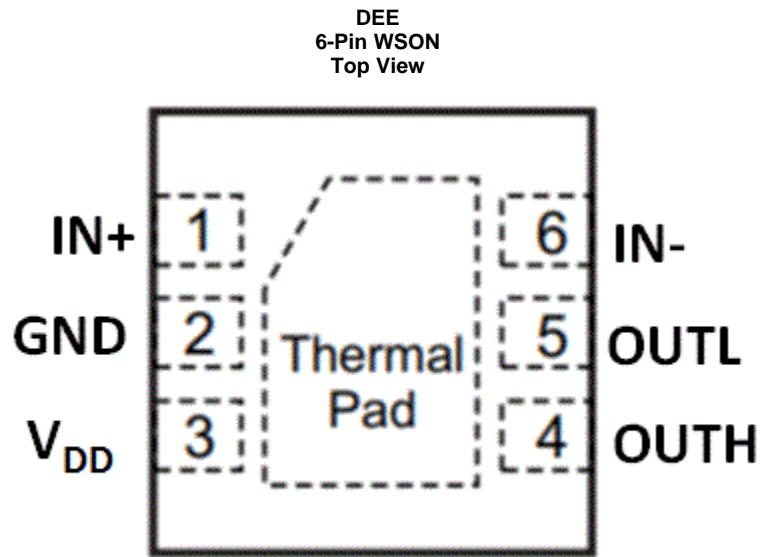

Pin Functions

PIN		I/O ⁽¹⁾	DESCRIPTION
NAME	NO.		
GND	2	G	Power supply and source return. Connect with a direct path to the transistor's source.
IN+	1	I	Positive logic-level input.
IN-	6	I	Negative logic-level input.
OUTL	5	O	Pull-down gate drive output. Connect through an optional resistor to the target transistor's gate.
OUTH	4	O	Pull-up gate drive output. Connect through a resistor to the target transistor's gate.
VDD	3	P	Input voltage supply. Decouple through a compact capacitor to GND.
Thermal Pad	-	-	Internally connected to GND through substrate. Connect this pad to large copper area, generally a ground plane.

(1) I=Input, O=Output, P=Power, G=Ground

6 Specifications

6.1 Absolute Maximum Ratings

All voltages are with respect to GND pin.⁽¹⁾

		MIN	MAX	UNIT
V _{DD}	Supply voltage	0	5.75	V
V _{IN}	IN+, IN- pin voltage	-0.3	V _{DD} + 0.3	V
V _{OUT}	OUTH, OUTL pin voltage	-0.3	5.75	V
T _{STG}	Storage Temperature	-55	150	°C
T _J	Operating Temperature	-40	150	°C

(1) Stresses beyond those listed under *Absolute Maximum Rating* may cause permanent damage to the device. These are stress ratings only, which do not imply functional operation of the device at these or any other conditions beyond those indicated under *Recommended Operating Condition*. Exposure to absolute-maximum-rated conditions for extended periods may affect device reliability.

6.2 ESD Ratings

			VALUE	UNIT
V _(ESD)	Electrostatic discharge	Human body model (HBM), per AEC Q100-002 ⁽¹⁾	±2000	V
		Charged device model (CDM), per AEC Q100-011	±500	

(1) AEC Q100-002 indicates that HBM stressing shall be in accordance with the ANSI/ESDA/JEDEC JS-001 specification.

6.3 Recommended Operating Conditions

over operating free-air temperature range (unless otherwise noted)

		MIN	NOM	MAX	UNIT
V _{DD}	Supply voltage	4.75	5	5.25	V
V _{INx}	IN+ or IN- input voltage	0		V _{DD}	V
V _{OUTx}	OUTH, OUTL pin voltage	0		5.25	V
T _J	Operating Temperature	-40		125	°C

6.4 Thermal Information

THERMAL METRIC ⁽¹⁾		LMG1025-Q1	UNIT
		DEE (WSON)	
		6 PINS	
R _{θJA}	Junction-to-ambient thermal resistance	66.7	°C/W
R _{θJC(top)}	Junction-to-case (top) thermal resistance	87.3	°C/W
R _{θJB}	Junction-to-board thermal resistance	30.8	°C/W
Ψ _{JT}	Junction-to-top characterization parameter	2.2	°C/W
Y _{JB}	Junction-to-board characterization parameter	30.7	°C/W
R _{θJC(bot)}	Junction-to-case (bottom) thermal resistance	6.7	°C/W

(1) For more information about traditional and new thermal metrics, see the [Semiconductor and IC Package Thermal Metrics](#) application report.

6.5 Electrical Characteristics

V_{DD} = 5V, good feed-through bypass capacitor from V_{DD} to GND pin, over operating free-air temperature range (unless otherwise noted)

PARAMETER		TEST CONDITIONS	MIN	TYP	MAX	UNIT
DC Characteristics						
I _{VDD, Q}	VDD Quiescent Current	IN ₊ = IN ₋ = 0 V			75	μA
I _{VDD, op}	VDD Operating Current	fsw = 30 MHz, no load, 2Ω as R _{OUTH} and R _{OUTL}		40		mA
		fsw = 30 MHz, 100-pF load, 2Ω as R _{OUTH} and R _{OUTL}		51		mA
V _{DD, UVLO}	Under-voltage Lockout	V _{DD} rising	4.0		4.35	V
ΔV _{DD, UVLO}	UVLO Hysteresis			85		mV
T _{OTP}	Over temperature shutdown, turn-off threshold			170		°C
ΔT _{OTP}	Over temperature hysteresis			20		°C
Input DC Characteristics						
V _{IH}	IN ₊ , IN ₋ high threshold		1.7		2.6	V
V _{IL}	IN ₊ , IN ₋ low threshold		1.1		1.8	V
V _{HYST}	IN ₊ , IN ₋ hysteresis		0.38		1	V
R _{IN+}	Positive input pull-down resistance	To GND	100	150	250	kΩ
R _{IN-}	Negative input pull-up resistance	to V _{DD}	100	150	250	kΩ
C _{IN+}	Positive input pin capacitance	To GND		1.45		pF
C _{IN-}	Negative input pin capacitance	To GND		1.45		pF
Output DC Characteristics						
V _{OL}	OUTL voltage	I _{OUTL} = 100 mA, IN ₊ = IN ₋ = 0 V			45	mV
V _{DD} -V _{OH}	OUTH voltage	I _{OUTH} = 100 mA, IN ₊ = 5 V, IN ₋ = 0 V, V _{DD} = 5 V			52	mV
I _{OH}	Peak source current	V _{OUTH} = 0 V, IN ₊ = 5 V, IN ₋ = 0 V, V _{DD} = 5 V		7		A
I _{OL}	Peak sink current	V _{OUTL} = 5 V, IN ₊ = IN ₋ = 0 V, V _{DD} = 5 V		5		A

6.6 Switching Characteristics

over operating free-air temperature range (unless otherwise noted)

PARAMETER		TEST CONDITIONS	MIN	TYP	MAX	UNIT
t _{start}	Startup Time, V _{DD} rising above UVLO	IN ₋ = GND, IN ₊ = V _{DD} , V _{DD} rising above 4.4 V to OUTH rising		40	78	μs
t _{shut-off}	ULVO falling	IN ₋ = GND, IN ₊ = V _{DD} , V _{DD} falling below 3.9 V to OUTH falling	0.7	2.5	3.5	μs
t _{pd, r}	Propagation delay, turn on	IN ₋ = 0 V, IN ₊ to OUTH, 100-pF load	1.5	2.6	4.1	ns
t _{pd, f}	Propagation delay, turn off	IN ₋ = 0 V, IN ₊ to OUTL, 100-pF load	1.8	2.9	4.4	ns
Δt _{pd}	Pulse positive distortion, (t _{pd, f} - t _{pd, r})		0	300	610	ps
t _{rise}	Output rise time	0Ω series 220 pF load ⁽¹⁾		650		ps
t _{fall}	Output fall time	0Ω series 220 pF load ⁽¹⁾		850		ps
t _{min}	Minimum input pulse width that changes output state	0Ω series 220 pF load ⁽¹⁾		1.25		ns

(1) Rise and fall time calculated as time from 20% of the gate voltage to 80% of the gate voltage of the GaN FET.

6.7 Typical Characteristics

VDD = 5 V

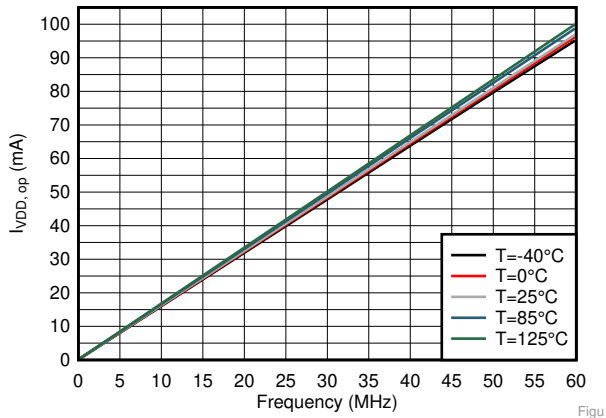

Figure 1. I_{VDD,op} with 2 Ω in series with 100 pF load

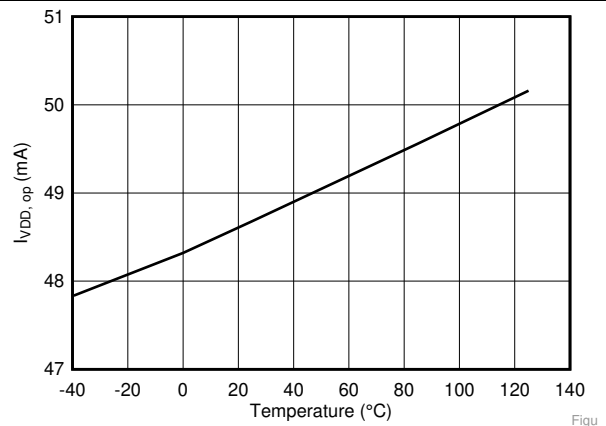

Figure 2. I_{VDD,op} with 2 Ω in series with 100 pF load

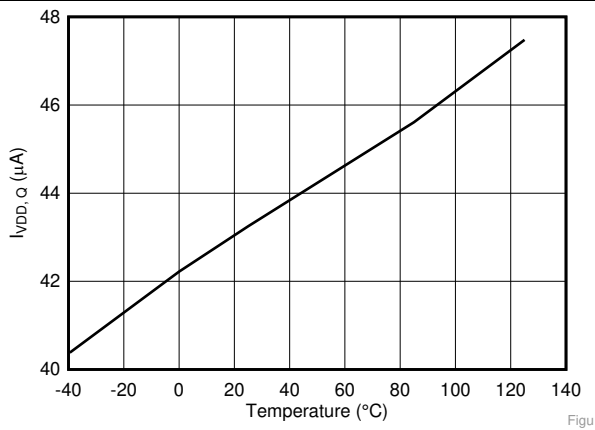

Figure 3. Quiescent current

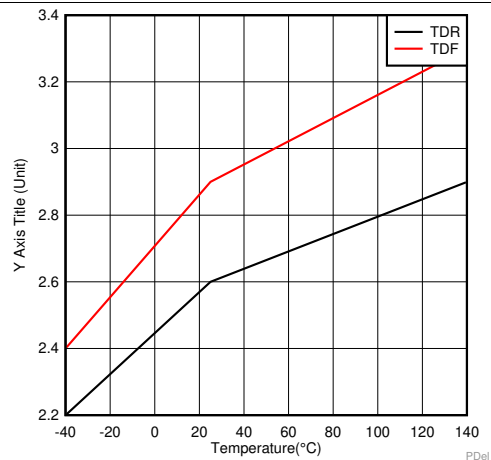

Figure 4. Propagation Delay with 1.8nC load

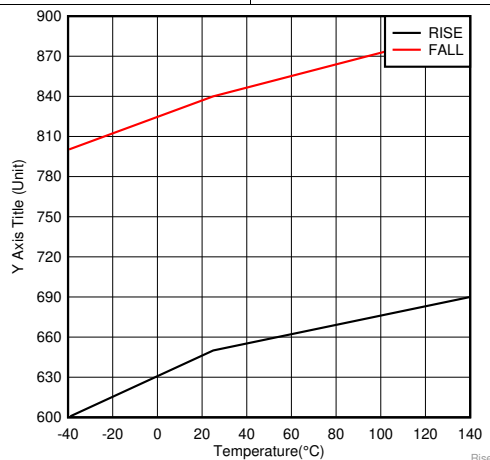

Figure 5. Rise And Fall Time with 1.8nC load

7 Detailed Description

7.1 Overview

LMG1025-Q1 is a high-performance low-side 5-V gate driver for GaN and logic-level MOSFETs. While it is designed to function well in high-speed applications, such as wireless power transmission and LiDAR/ToF, it can be used in any application where a low-side gate driver is required. The LMG1025-Q1 is optimized to provide the lowest propagation delay through the driver to the power transistor. LMG1025-Q1 is in a small 2mm×2mm QFN package with wettable flanks, in order to minimize its parasitic inductance. This low inductance design is necessary to achieve high current, low ringing performance in very high frequency operation when driving power FETs. The same holds true for when designing with LMG1025-Q1. QFN package with wettable flanks is also needed to improve system robustness in many automotive applications.

7.2 Functional Block Diagram

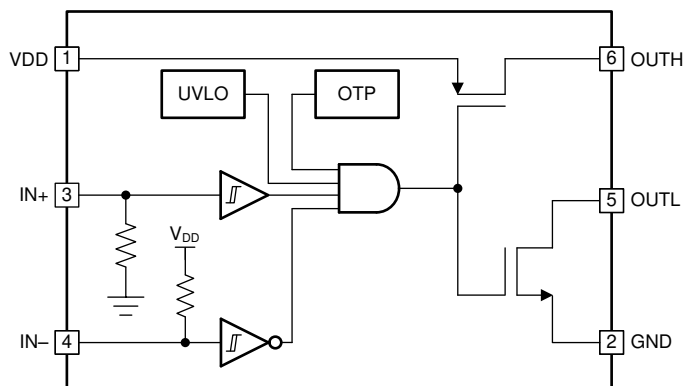

7.3 Feature Description

7.3.1 Input Stage

The input stage features two Schmitt-triggers at the pins IN+ and IN– to reduce sensitivity to noise on the inputs. IN+ signal and the inverted IN– signal are both sent to an AND gate. IN+ is connected with a pull-down resistor while IN– is connected with a pull-up resistor to prevent unintended turn-on. The output of the driver will be high when input voltage goes above input thresholds and output goes low when input voltage is below input threshold mentioned in the electrical characteristics table. Both IN+ and IN– are single ended inputs, and these two pins cannot be used as a differential input pair. Parasitic elements become extremely important in high frequency designs and extreme care should be taken while laying out the printed circuit board to minimize these parasitic elements. The performance of the LMG1025-Q1 and the performance of the overall system gets affected by the layout and components being selected.

7.3.2 Output Stage

LMG1025-Q1 provides 7-A source, 5-A sink (asymmetrical drive) peak-drive current capability, and features a split output configuration. The OUTH and OUTL outputs of the LMG1025-Q1 allow the user to use independent resistors connecting to the gate. The two resistors allow the user to independently adjust the turn-on and turn-off drive strengths to control slew rate and EMI, and to control ringing on the gate signal. For GaN FETs, controlling ringing is important to reduce stress on the GaN FET and driver. The output stage OUTL is also pulled down in undervoltage condition, which prevents the unintended charge accumulation of device Ciss, and thus preventing false turn-on. This ringing heavily depends on the layout as switching frequency increases and as rise and fall time gets shorter. The distance between the gate driver and power device need to be as minimum as possible. Gate loop should be as minimum as possible. If ringing is un-avoidable then the gate resistor should be selected in such a way that the ringing is minimized. Bypass capacitor type, value, and position also significantly affects this ringing.

Feature Description (continued)

7.3.3 Bias Supply and Under Voltage Lockout

LMG1025-Q1 features nominal 5 V and maximum 5.25 V of supply voltage, and its absolute maximum supply voltage is 5.75 V. In the design, it is recommended to limit the variability of the power supply to be within 5% (0.25 V), and the overshoot voltage during switching transient not to exceed the absolute maximum voltage. Refer to Section VDD and Overshoot for more on the detailed design guide. LMG1025-Q1 also features internal undervoltage lockout (UVLO) to protect the driver and circuit in case of fault conditions. The UVLO point is setup between 4.0 V and 4.35 V with a hysteresis of 85mV. This UVLO level is specifically designed to guarantee that GaN power devices can be switched at a low $R_{DS(ON)}$ region. During UVLO condition, the OUTL pin is pulled down to ground.

7.3.4 Overtemperature Protection (OTP)

LMG1025-Q1 features overtemperature protection (OTP) function by having a rising edge trigger point at around 170°C of junction temperature. With a hysteresis of 20°C, the device can restart to operate when junction temperature is below 150°C.

7.4 Device Functional Modes

The device will operate in following mode when not in UVLO state.

Table 1. Truth Table

IN-	IN+	OUTH	OUTL
L	L	Open	L
L	H	H	Open
H	L	Open	L
H	H	Open	L

8 Application and Implementation

NOTE

Information in the following applications sections is not part of the TI component specification, and TI does not warrant its accuracy or completeness. TI's customers are responsible for determining suitability of components for their purposes. Customers should validate and test their design implementation to confirm system functionality.

8.1 Application Information

To operate GaN FET or MOSFET at very high switching frequencies and to reduce associated switching losses, a powerful gate driver is employed between the PWM output of controller and the gate of the GaN transistor. Also, gate drivers are indispensable when the outputs of the PWM controller do not meet the voltage or current levels needed to directly drive the gates of the switching devices. With the advent of digital power, this situation is often encountered because the PWM signal from the digital controller is often a 3.3-V logic signal, which cannot effectively turn on a power switch. A level-shift circuit is needed to boost the 3.3-V signal to the gate-drive voltage (such as 5 V) in order to fully turn on the power device and minimize conduction losses.

Gate drivers effectively provide the buffer-drive functions. Gate drivers also address other needs such as minimizing the effect of high-frequency switching noise (by placing the high-current driver IC physically close to the power switch), reducing power dissipation and thermal stress in controllers by moving gate charge power losses from the controller into the driver.

The LMG1025-Q1 is a high frequency low-side gate driver for enhancement mode GaN FETs and Si FETs in a single ended configuration. The split-gate outputs with strong source and sink capability provides flexibility to adjust the turn-on and turn-off strength independently. As a low side driver, LMG1025-Q1 can be used in a variety of applications, including different power converters, LiDAR, time-of-flight (ToF) laser drivers, class-E wireless chargers, synchronous rectifiers, and augmented reality devices. LMG1025-Q1 can also be used as a high frequency low current laser diode driver, or as a signal buffer with very fast rise/fall time.

8.2 Typical Application

The LMG1025-Q1 is designed to be used with a single low-side, ground-referenced GaN or logic-level FET, as shown in [Figure 6](#). Independent gate drive resistors, R1 and R2, are used to independently control the turnon and turnoff drive strengths, respectively. For fast and strong turnoff, R2 can be shorted and OUTL directly connected to the transistor's gate. For symmetric drive strengths, it is acceptable to short OUTH and OUTL and use a single gate-drive resistor. The care should be taken that the ringing on the gate of the power device or ringing on any of the gate driver pin does not exceed the recommended rating. Resistors play an important role in damping these ringing. The layout and type of gate resistor with respect to gate driver and power device is also very important.

It is strongly recommended to use at least a 2-Ω resistor at each OUTH and OUTL to avoid voltage overstress due to inductive ringing. Ringing has to be ensured to be below $V_{DD}+0.3$ V.

For applications requiring smaller resistance, please contact the factory for guidance.

Typical Application (continued)

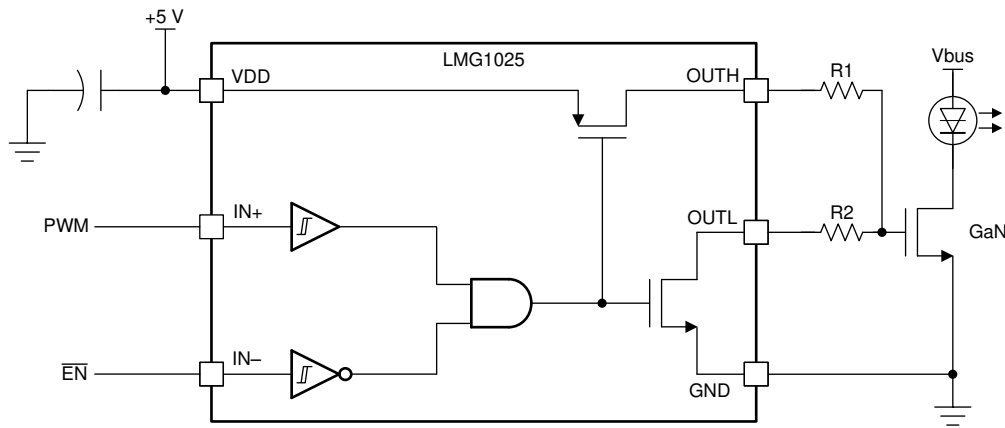

Figure 6. Typical Implementation of a Circuit

8.2.1 Design Requirements

When designing a multi-MHz (or nano-second pulse) application that incorporates the LMG1025-Q1 gate driver and GaN power FETs, some design considerations must be evaluated first to make the most appropriate selection. Among these considerations are layout optimization, circuit voltages, passive components, operating frequency, and controller selection.

8.2.2 Detailed Design Procedure

8.2.2.1 Handling Ground Bounce

For the best switching performance and gate loop with lowest parasitics, it is recommended to connect the ground return pin of LMG1025-Q1 as close as possible to the source of the low-side FET in a low inductance manner. However, doing so can cause the ground of LMG1025-Q1 to bounce relative to the system or controller ground and lead to erroneous switching logic so as mis-turn on/off on the output.

First of all, LMG1025-Q1 has input hysteresis built into the input buffers to help counteract this effect. The maximum di/dt allowed to prevent the input voltage transient from exceeding the input hysteresis is given by [Equation 1](#)

$$\frac{di_s}{dt} = \frac{V_{HYST}}{L_{RS}}$$

where

- L_{RS} is the inductance of the sense resistor,
- V_{HYST} is the hysteresis of the input pin,
- and di_s/dt is the maximum allowed current slew rate.

(1)

For an assumed shunt resistor parasitic inductance of 0.5 nH and a minimum hysteresis of 0.5 V, the maximum slew rate is 1 A/ns. Many applications would exhibit higher current slew rates, up to the 10 A/ns range, which would make this approach impractical. The stability of this approach can be improved by using the IN– input for the PWM signal and locally tying IN+ to VDD. By using the inverting input, the transient voltage applied to the input pin reinforces the PWM signal in a positive feedback loop. While this approach would reduce the probability of false pulses or oscillation, the transient spikes due to high di/dt may overly stress the inputs to the LMG1025-Q1. A current-limiting, 100 Ω resistor can be placed right before the IN– input to limit excessive current spikes in the device.

Typical Application (continued)

Secondly, for moderate ground-bounce cases, a simple R-C filter can be built with a simple resistor in series with the inputs. By utilizing the input capacitance of LMG1025-Q1, the resistor could be close to its input pin. The addition of a small capacitor on the input as supplement can also be helpful. A small time constant of the R-C filter may be enough to filter out high frequency noise. This solution is acceptable for moderate cases in applications where extra delay is acceptable and the pulse width is not extremely short such as in 1ns range.

For more extreme cases, or where no delay is tolerable while pulse width is extremely short, using a commonmode choke provides the best results.

One example application where ground-bounce is particularly challenging is when using a current sense resistor. In Figure 7 LMG1025-Q1 ground is connected to the source of GaN FET, while the controller ground is connected to the other side of the current sense resistor as shown in Figure 7. Due to the fast switching and very fast current slew rates, the high ground potential bounce induced by inductance of the sense resistor can disrupt the operation of the circuit or even damage the part. To prevent this, a common-mode choke can be used for IN+ and IN-, respectively. Resistors can also added to the signal output line before LMG1025-Q1 depending on the input signal pulse width to provide additional RC filtering. Figure 9 presents the schematic using approach A with the preferred filtering method. Approach B as shown in Figure 8 places the current sense resistor within the gate drive loop path. In this case, the LMG1025-Q1 GND pin is connected to the signal ground, and with good ground plane connection, the ground bounce issue can be less severe than approach A. However, the inductance of the current sense resistor adds common-source inductance to the gate drive loop. The voltage generated across this parasitic inductance will subtract from the gate-drive voltage of the FET, slowing down the turnon and turnoff di/dt of the FET, or even cause mis-turn on and off. Additional gate resistance will have to be added to ensure the loop is stable and ring-free. The slower rise may negate the advantage of the fast switching of the GaN FET and may cause additional losses in the circuit. Therefore, this approach is not recommended.

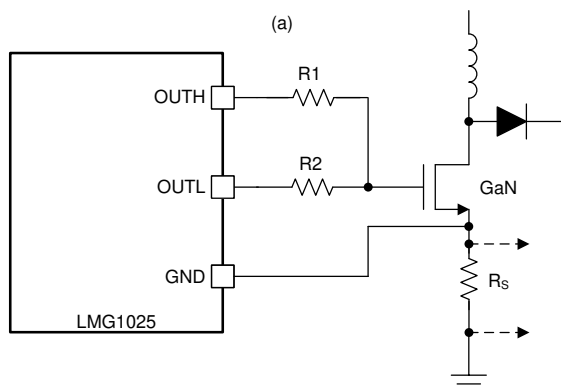

Figure 7. Source Resistor Current Sense A Configuration

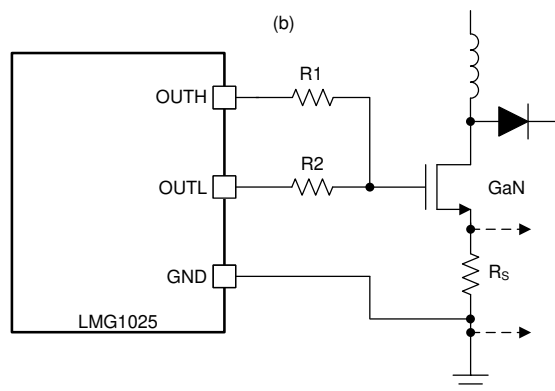

Figure 8. Source Resistor Current Sense B Configuration

Typical Application (continued)

Figure 9. Filtering For Ground Bounce Noise Handling When Using LMG1025-Q1

8.2.2.2 Creating Nanosecond Pulse

LMG1025-Q1 can be used to drive pulses of nano seconds duration on to a capacitive load. LMG1025-Q1 can be driven with a equivalently short pulse on one input pin. However, this takes a sufficiently strong digital driver and careful consideration of the routing parasitics from digital output to input of LMG1025-Q1. Two inputs and included AND gate in LMG1025-Q1 provide an alternate method to create a short pulse at the LMG1025-Q1 output. Starting with both IN+ and IN- at low, taking IN+ high will cause the output to go high. Now if IN- is taken high as well, output will be pulled low. So a digital signal and its delayed version can be applied to IN+ and IN- respectively to create a pulse at the output with width corresponding to the delay between the signals, as shown in Figure 10. The delay can be digitally controlled in the nanosecond range. This method alleviates the requirements for driving the input of LMG1025-Q1. If a separate delayed version of the digital signal is not available, an RC delay followed by a buffer can be used to derive the second signal. Optionally, if LMG1025-Q1 must be driven with a single short duration pulse, that pulse can itself be generated using another LMG1025-Q1 by the above method to meet drive requirements.

Typical Application (continued)

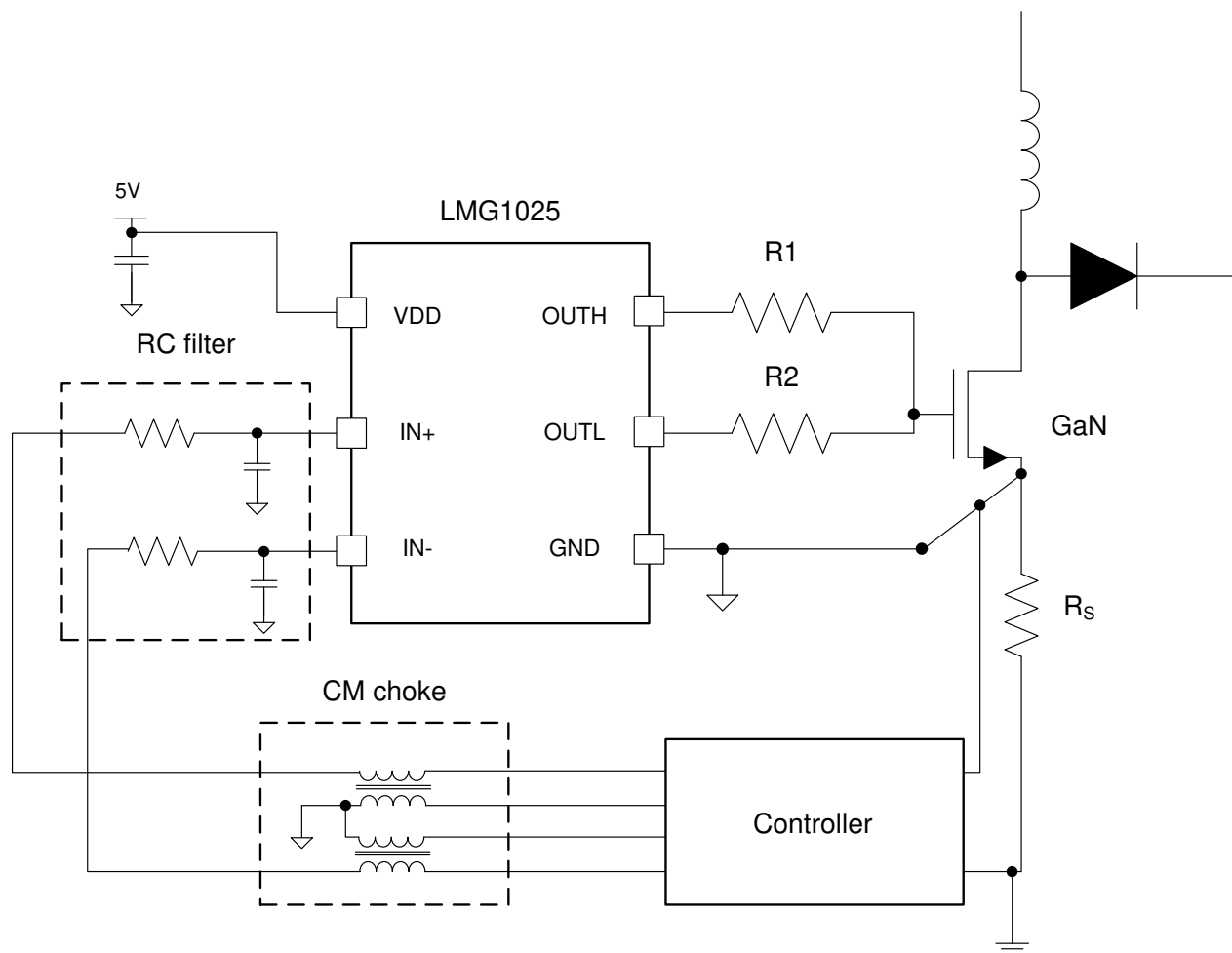
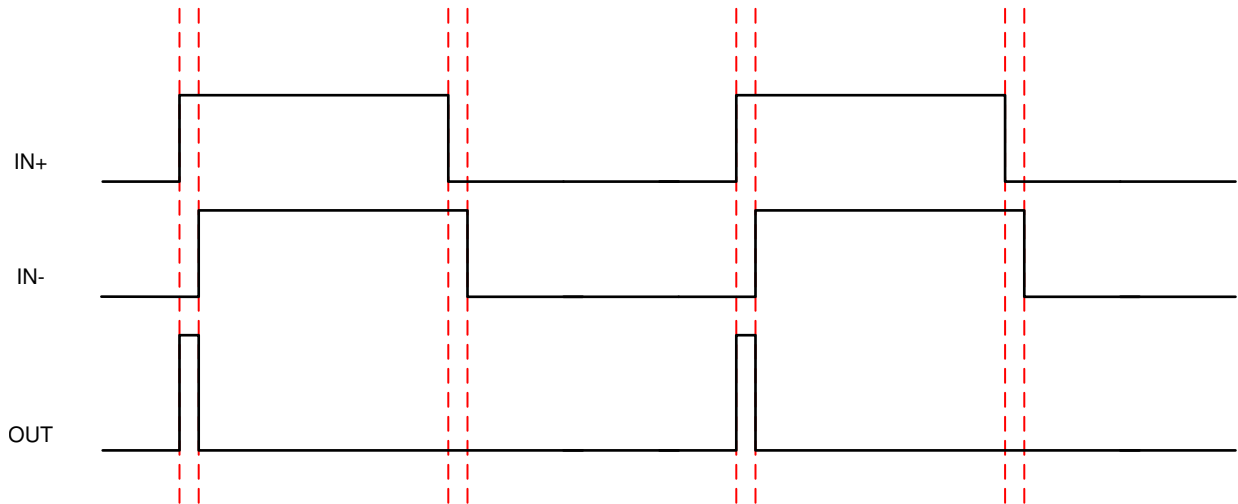

Figure 10. Timing Diagram To Create Short Pulses

8.2.3 VDD and Overshoot

Fast switching with high current is prone to ringing with parasitic inductances, including those on PCB traces. Overshoot associated with such ringing transients need to be evaluated and controlled as a part of the PCB design process to limit device stress. The parameters affecting stress are how high the overshoot is above the absolute maximum specification and the ratio of overshoot duration to the switching time period. Recommended design practice is to limit the overshoots to the absolute maximum pin voltages. This is accomplished with careful PCB layout to minimize parasitic inductances, choice of components with low ESL and addition of series resistance to limit rise times. For large overshoots, limiting the variability of the power supply may be required. For example, 0.5V of overshoot will be permissible with a maximum recommended supply of 5.25 V (5% variability); however, for larger overshoots, a supply with lower variability will be preferred.

8.2.4 Operating at Higher Frequency

With fast rise/fall time, and capability of achieving nano-second pulse width, depending on the capacitive load condition, the operating frequency of LMG1025-Q1 can be increased in a burst manner. In conditions which requires very high frequency pulsing, a pulse train with certain period of pause between each burst can be adopted to avoid overheat of the device. This will help maintain the RMS output current similar as lower frequency operation but boost the transient frequency to very high. In addition, higher decoupling capacitance will be needed to supply high frequency charging of the capacitive load.

8.2.5 Application Curves

LMG1025-Q1 EVM is used to take application waveforms. This EVM has LDO, input buffer, GaN FET, and load resistor. It shows the switching performance of the LMG1025-Q1 when equivalent laser diode current is switched. Figure 11 and Figure 12 show VDD turn-on and turn-off delay in an application-like set-up. System designer need to make sure that these delays are acceptable in their designs. LIDAR design needs to pulse the laser diode for very short duration. Figure 13 shows how LMG1025-Q1 can not only handle nano-second pulse at its input but also can produce a nano-second pulse at the output while driving a reasonably sized GaN FET that has 3.2nC of typical total gate charge. Figure 13 also shows very small, e.g. less than 3 ns, rising and falling propagation delay of LMG1025-Q1. Figure 14 shows drive strength of LMG1025-Q1. It shows how LMG1025-Q1 can achieve sub-nano second rise and fall time, which is very important for LIDAR applicatoins.

Typical Application (continued)

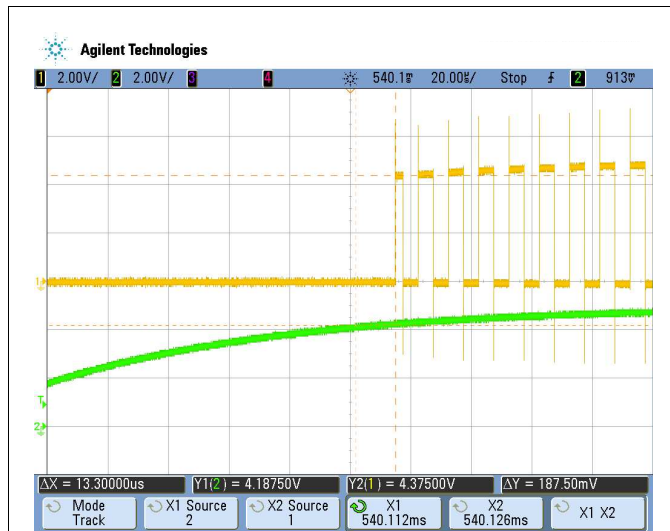

Figure 11. Startup Time

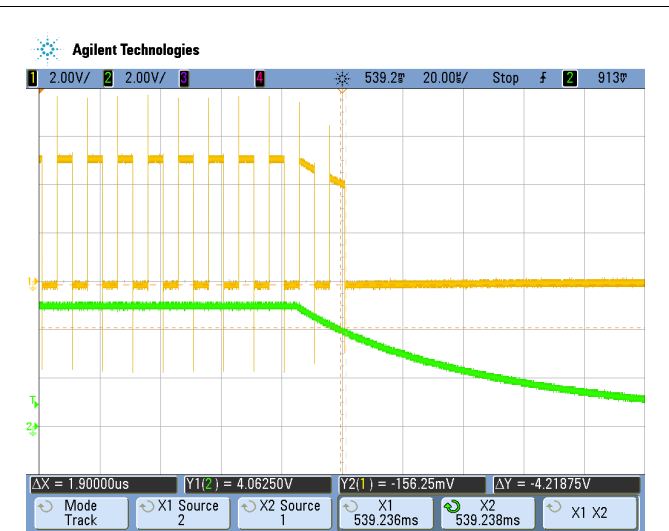

Figure 12. Shutdown Time

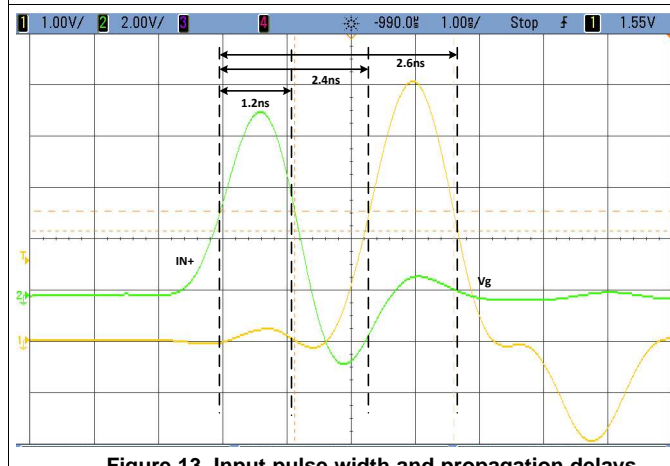

Figure 13. Input pulse width and propagation delays

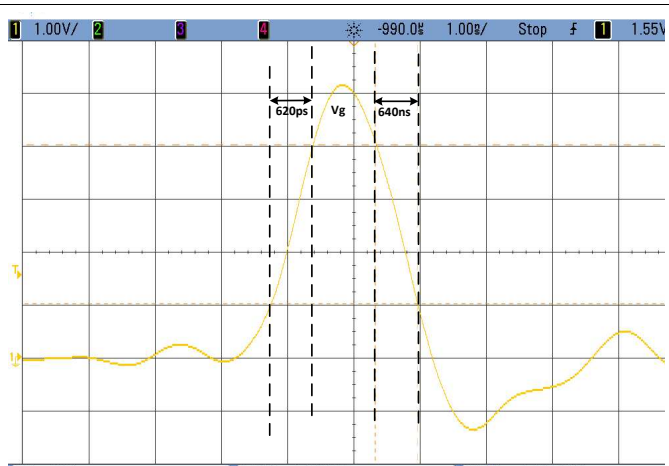

Figure 14. Rise and fall time

9 Power Supply Recommendations

A low-ESR/ESL ceramic capacitor must be connected close to the IC, between VDD and GND pins to support the high peak current being drawn from VDD during turnon of the FETs. It is most desirable to place the VDD decoupling capacitor on the same side of the PC board as the driver. The inductance of via holes can impose excessive ringing on the IC pins.

TI recommends the use of a three-terminal capacitor connecting in shunt-through manner to achieve the lowest ESL and best transient performance. This capacitor can be placed as close as possible to the IC, while another capacitor in larger capacitance can be placed closely to the three-terminal cap to supply enough charge but with slightly lower bandwidth. As a general practice, the combination of a 0.1 μF of 0402 or feed-through capacitor (closest to LMG1025-Q1) and a 1 μF 0603 capacitor is recommended.

10 Layout

10.1 Layout Guidelines

The layout of the LMG1025-Q1 is critical to its performance and functionality. The LMG1025-Q1 is available in a 2x2 DFN, which allows a low inductance connection to a FET. Figure 15 shows the recommended layout of the LMG1025-Q1 with a ball-grid GaN FET.

A four-layer or higher layer count board is required to reduce the parasitic inductances of the layout to achieve suitable performance. To minimize inductance and board space, resistors and capacitors in the 0201 package should be used here. The gate drive power loss must be calculated to ensure an 0201 resistor will be able to handle the power level.

10.1.1 Gate Drive Loop Inductance and Ground Connection

A compact, low-inductance gate-drive loop is essential to achieving fast switching frequencies with the LMG1025-Q1. The LMG1025-Q1 should be placed as close to the GaN FET as possible, with gate drive resistors immediately connecting OUTH and OUTL to the FET gate. Large traces need to be used to minimize resistance and parasitic inductance.

To minimize gate drive loop inductance, the source return should be on layer 2 of the PCB, immediately under the component (top) layer. Vias immediately adjacent to both the FET source and the LMG1025-Q1 GND pin connect to this plane with minimal impedance. Finally, care must be taken to connect the GND plane to the source power plane only at the FET to minimize common-source inductance and to reduce coupling to the ground plane.

10.1.2 Bypass Capacitor

The VDD power terminal of the LMG1025-Q1 must be bypassed to ground immediately adjacent to the IC. The placement and value of the bypass capacitor is very critical because of the fast gate drive of the IC. The bypass capacitor must be located on the top layer, as close as possible to the IC, and connected to both VDD and GND using large power planes. This bypass capacitor has to be at least a 0.1 μF , up to 1 μF , with temperature coefficient X7R or better. Recommended body types are LICC, IDC, Feed-through, and LGA. Finally, an additional 1 μF capacitor should be placed as close to the IC as practical.

10.2 Layout Example

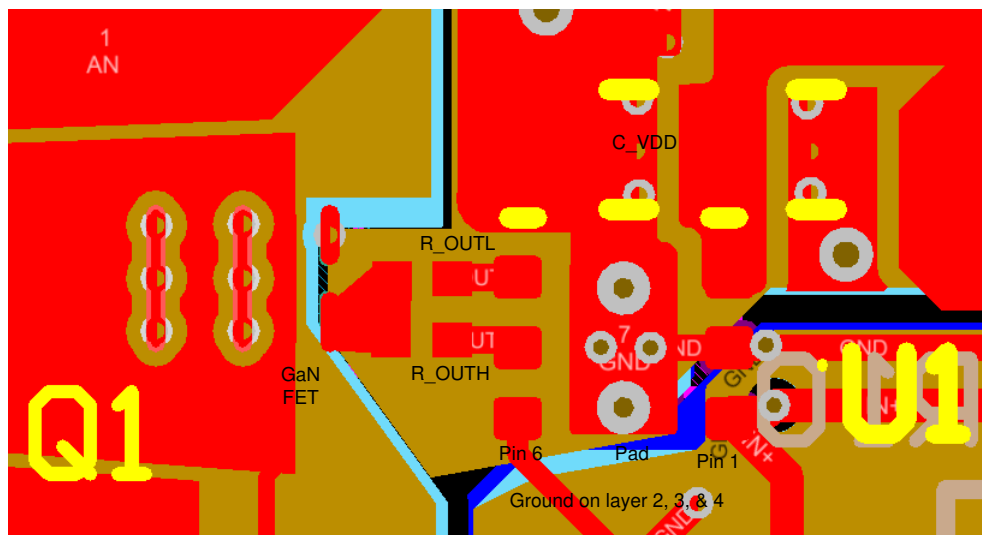

Figure 15. Typical LMG1025-Q1 Layout With Ball-Grid GaN FET

11 Device and Documentation Support

11.1 Receiving Notification of Documentation Updates

To receive notification of documentation updates, navigate to the device product folder on ti.com. In the upper right corner, click on *Alert me* to register and receive a weekly digest of any product information that has changed. For change details, review the revision history included in any revised document.

11.2 Support Resources

TI E2E™ [support forums](#) are an engineer's go-to source for fast, verified answers and design help — straight from the experts. Search existing answers or ask your own question to get the quick design help you need.

Linked content is provided "AS IS" by the respective contributors. They do not constitute TI specifications and do not necessarily reflect TI's views; see TI's [Terms of Use](#).

11.3 Trademarks

E2E is a trademark of Texas Instruments.

All other trademarks are the property of their respective owners.

11.4 Electrostatic Discharge Caution



This integrated circuit can be damaged by ESD. Texas Instruments recommends that all integrated circuits be handled with appropriate precautions. Failure to observe proper handling and installation procedures can cause damage.

ESD damage can range from subtle performance degradation to complete device failure. Precision integrated circuits may be more susceptible to damage because very small parametric changes could cause the device not to meet its published specifications.

11.5 Glossary

[SLYZ022](#) — *TI Glossary*.

This glossary lists and explains terms, acronyms, and definitions.

12 Mechanical, Packaging, and Orderable Information

The following pages include mechanical, packaging, and orderable information. This information is the most current data available for the designated devices. This data is subject to change without notice and revision of this document. For browser-based versions of this data sheet, refer to the left-hand navigation.

PACKAGING INFORMATION

Orderable Device	Status (1)	Package Type	Package Drawing	Pins	Package Qty	Eco Plan (2)	Lead finish/ Ball material (6)	MSL Peak Temp (3)	Op Temp (°C)	Device Marking (4/5)	Samples
LMG1025QDEERQ1	ACTIVE	WSON	DEE	6	3000	RoHS & Green	SN	Level-2-260C-1 YEAR	-40 to 125	LMG	Samples
LMG1025QDEETQ1	ACTIVE	WSON	DEE	6	250	RoHS & Green	SN	Level-2-260C-1 YEAR	-40 to 125	LMG	Samples

(1) The marketing status values are defined as follows:

ACTIVE: Product device recommended for new designs.

LIFEBUY: TI has announced that the device will be discontinued, and a lifetime-buy period is in effect.

NRND: Not recommended for new designs. Device is in production to support existing customers, but TI does not recommend using this part in a new design.

PREVIEW: Device has been announced but is not in production. Samples may or may not be available.

OBsolete: TI has discontinued the production of the device.

(2) **RoHS:** TI defines "RoHS" to mean semiconductor products that are compliant with the current EU RoHS requirements for all 10 RoHS substances, including the requirement that RoHS substance do not exceed 0.1% by weight in homogeneous materials. Where designed to be soldered at high temperatures, "RoHS" products are suitable for use in specified lead-free processes. TI may reference these types of products as "Pb-Free".

RoHS Exempt: TI defines "RoHS Exempt" to mean products that contain lead but are compliant with EU RoHS pursuant to a specific EU RoHS exemption.

Green: TI defines "Green" to mean the content of Chlorine (Cl) and Bromine (Br) based flame retardants meet JS709B low halogen requirements of <=1000ppm threshold. Antimony trioxide based flame retardants must also meet the <=1000ppm threshold requirement.

(3) MSL, Peak Temp. - The Moisture Sensitivity Level rating according to the JEDEC industry standard classifications, and peak solder temperature.

(4) There may be additional marking, which relates to the logo, the lot trace code information, or the environmental category on the device.

(5) Multiple Device Markings will be inside parentheses. Only one Device Marking contained in parentheses and separated by a "~" will appear on a device. If a line is indented then it is a continuation of the previous line and the two combined represent the entire Device Marking for that device.

(6) Lead finish/Ball material - Orderable Devices may have multiple material finish options. Finish options are separated by a vertical ruled line. Lead finish/Ball material values may wrap to two lines if the finish value exceeds the maximum column width.

Important Information and Disclaimer:The information provided on this page represents TI's knowledge and belief as of the date that it is provided. TI bases its knowledge and belief on information provided by third parties, and makes no representation or warranty as to the accuracy of such information. Efforts are underway to better integrate information from third parties. TI has taken and continues to take reasonable steps to provide representative and accurate information but may not have conducted destructive testing or chemical analysis on incoming materials and chemicals. TI and TI suppliers consider certain information to be proprietary, and thus CAS numbers and other limited information may not be available for release.

In no event shall TI's liability arising out of such information exceed the total purchase price of the TI part(s) at issue in this document sold by TI to Customer on an annual basis.

TAPE AND REEL INFORMATION



QUADRANT ASSIGNMENTS FOR PIN 1 ORIENTATION IN TAPE



*All dimensions are nominal

Device	Package Type	Package Drawing	Pins	SPQ	Reel Diameter (mm)	Reel Width W1 (mm)	A0 (mm)	B0 (mm)	K0 (mm)	P1 (mm)	W (mm)	Pin1 Quadrant
LMG1025QDEERQ1	WSON	DEE	6	3000	180.0	8.4	2.2	2.2	1.2	4.0	8.0	Q2
LMG1025QDEETQ1	WSON	DEE	6	250	180.0	8.4	2.2	2.2	1.2	4.0	8.0	Q2

TAPE AND REEL BOX DIMENSIONS

*All dimensions are nominal

Device	Package Type	Package Drawing	Pins	SPQ	Length (mm)	Width (mm)	Height (mm)
LMG1025QDEERQ1	WSON	DEE	6	3000	213.0	191.0	35.0
LMG1025QDEETQ1	WSON	DEE	6	250	213.0	191.0	35.0

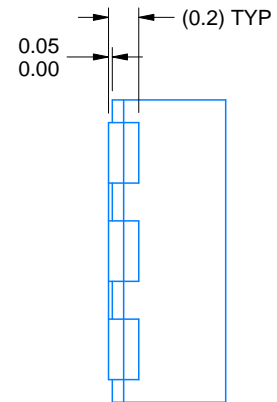
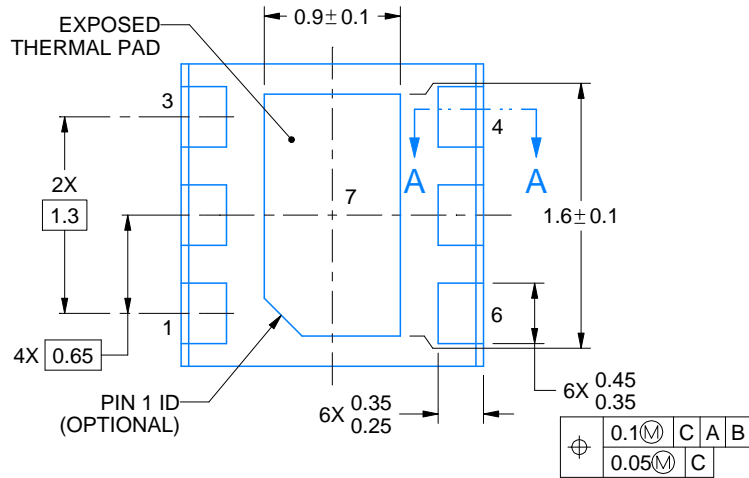
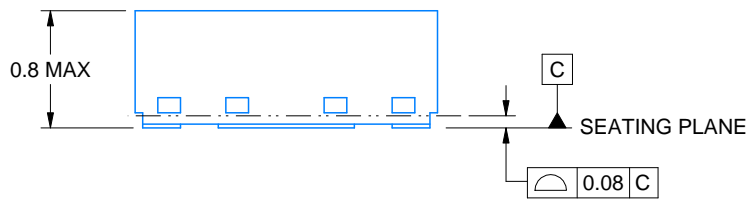
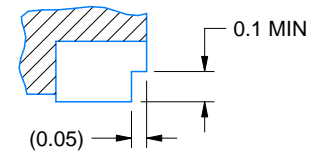
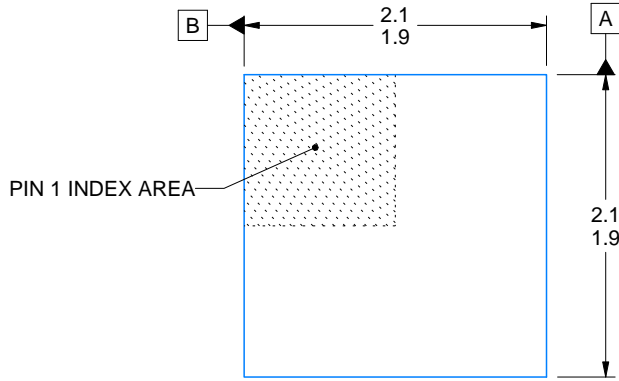
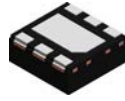

4219364/A 01/2019

NOTES:

1. All linear dimensions are in millimeters. Any dimensions in parenthesis are for reference only. Dimensioning and tolerancing per ASME Y14.5M.
2. This drawing is subject to change without notice.

EXAMPLE BOARD LAYOUT

DEE0006A

WSON - 0.8 mm max height

PLASTIC SMALL OUTLINE - NO LEAD

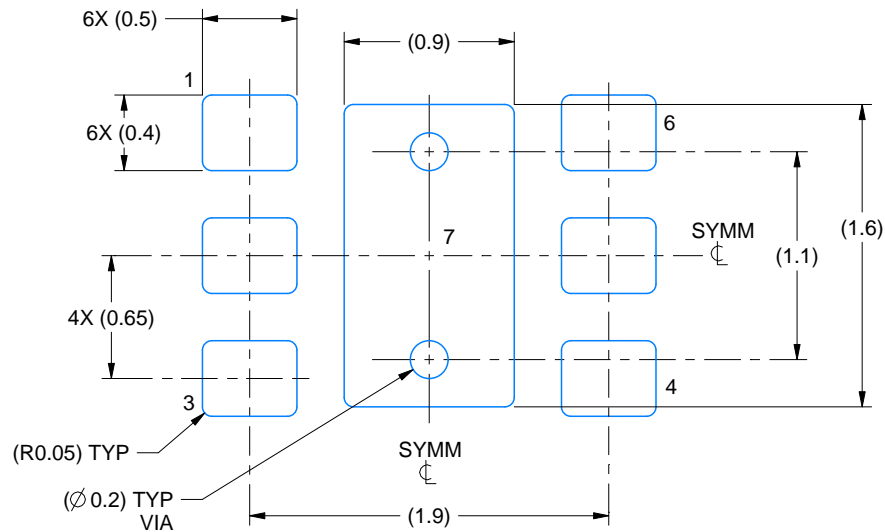

LAND PATTERN EXAMPLE
EXPOSED METAL SHOWN
SCALE:25X

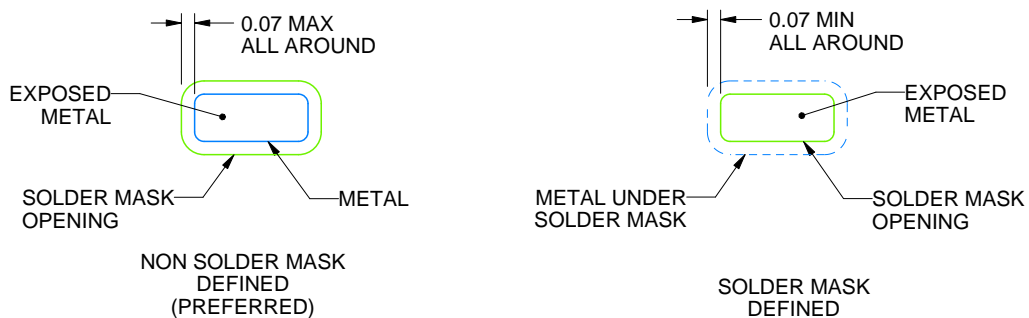

SOLDER MASK DETAILS

4219364/A 01/2019

NOTES: (continued)

3. For more information, see Texas Instruments literature number SLUA271 (www.ti.com/lit/sluea271).
4. Vias are optional depending on application, refer to device data sheet. If any vias are implemented, refer to their locations shown on this view. It is recommended that vias under paste be filled, plugged or tented.

EXAMPLE STENCIL DESIGN

DEE0006A

WSON - 0.8 mm max height

PLASTIC SMALL OUTLINE - NO LEAD

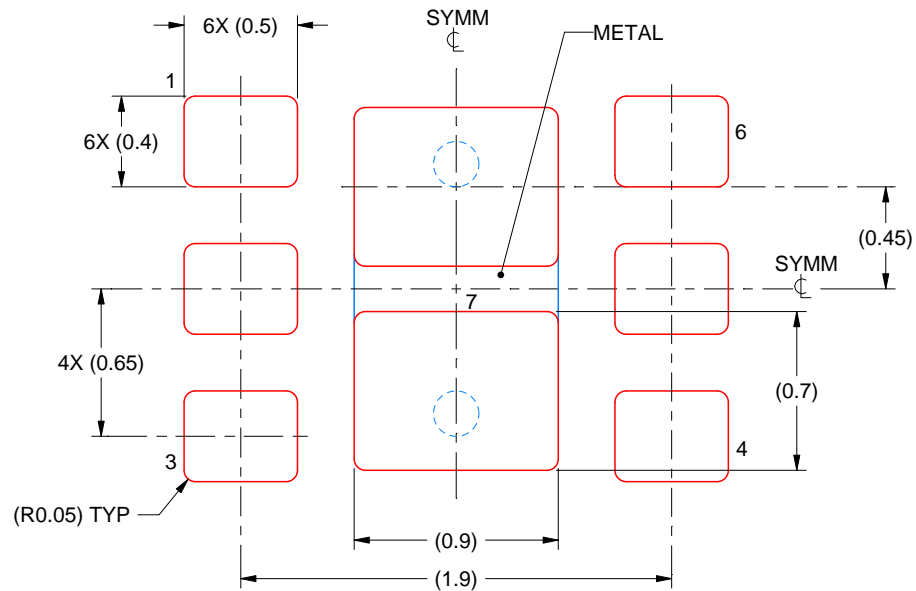

SOLDER PASTE EXAMPLE
BASED ON 0.125 mm THICK STENCIL

EXPOSED PAD #7:
88% PRINTED SOLDER COVERAGE BY AREA UNDER PACKAGE
SCALE:30X

4219364/A 01/2019

NOTES: (continued)

5. Laser cutting apertures with trapezoidal walls and rounded corners may offer better paste release. IPC-7525 may have alternate design recommendations.

IMPORTANT NOTICE AND DISCLAIMER

TI PROVIDES TECHNICAL AND RELIABILITY DATA (INCLUDING DATASHEETS), DESIGN RESOURCES (INCLUDING REFERENCE DESIGNS), APPLICATION OR OTHER DESIGN ADVICE, WEB TOOLS, SAFETY INFORMATION, AND OTHER RESOURCES "AS IS" AND WITH ALL FAULTS, AND DISCLAIMS ALL WARRANTIES, EXPRESS AND IMPLIED, INCLUDING WITHOUT LIMITATION ANY IMPLIED WARRANTIES OF MERCHANTABILITY, FITNESS FOR A PARTICULAR PURPOSE OR NON-INFRINGEMENT OF THIRD PARTY INTELLECTUAL PROPERTY RIGHTS.

These resources are intended for skilled developers designing with TI products. You are solely responsible for (1) selecting the appropriate TI products for your application, (2) designing, validating and testing your application, and (3) ensuring your application meets applicable standards, and any other safety, security, or other requirements. These resources are subject to change without notice. TI grants you permission to use these resources only for development of an application that uses the TI products described in the resource. Other reproduction and display of these resources is prohibited. No license is granted to any other TI intellectual property right or to any third party intellectual property right. TI disclaims responsibility for, and you will fully indemnify TI and its representatives against, any claims, damages, costs, losses, and liabilities arising out of your use of these resources.

TI's products are provided subject to TI's Terms of Sale (<https://www.ti.com/legal/termsofsale.html>) or other applicable terms available either on [ti.com](https://www.ti.com) or provided in conjunction with such TI products. TI's provision of these resources does not expand or otherwise alter TI's applicable warranties or warranty disclaimers for TI products.

Mailing Address: Texas Instruments, Post Office Box 655303, Dallas, Texas 75265
Copyright © 2021, Texas Instruments Incorporated