

LMR10520 5.5V_{IN}、2A 降圧型電圧レギュレータ、WSO_N パッケージ

1 特長

- 3V~5.5V の入力電圧範囲
- 0.6V~4.5V の出力電圧範囲
- 最大 2A の出力電流
- 1.6MHz (LMR10520X) および 3MHz (LMR10520Y) のスイッチング周波数
- 低いシャットダウン I_Q : 30nA (標準値)
- 内部ソフトスタート
- 内部補償
- 電流モード PWM 動作
- サーマル・シャットダウン
- ソリューション全体の小型化によりシステムのコストを削減
- WSO_N (3 × 3 × 0.8mm) パッケージ
- WEBENCH[®] Power Designer により、LMR10520 を使用するカスタム設計を作成

2 アプリケーション

- 3.3Vおよび5Vレールからのポイント・オブ・ロード(POL)変換
- スペースに制約のあるアプリケーション
- バッテリ駆動の機器
- 産業用分散電源アプリケーション
- パワー・メーター
- 携帯用ハンドヘルド計測器

3 概要

LMR10520 レギュレータは、6 ピン WSO_N パッケージのモノリシック高周波数 PWM 降圧型 DC/DC コンバータです。ローカル DC/DC 変換に必要なアクティブ機能をすべて内蔵し、高速過渡応答と正確なレギュレーションを、極めて小さな PCB 面積で実現しています。LMR10520 は必要な外付け部品が最小限であるため簡単に使用できます。内蔵の 150mΩ PMOS スイッチで 2A の負荷を駆動できるため、電力密度を最大限に高めることができます。世界最先端の制御回路により、最短で 30ns のオン時間を実現することから、3V~5.5V の入力動作範囲にわたって最小 0.6V の出力電圧に極めて高い周波数で変換できます。LMR10520 は内部で補償されているため使いやすく、外付け部品はほとんど不要です。動作周波数が高いにもかかわらず、最高 93% の高い効率を簡単に実現できます。外部からのシャットダウン機能を備えており、スタンバイ電流が 30nA と非常に低くなっています。LMR10520 は電流モード制御と内部補償を使用し、広範な動作条件にわたって高性能のレギュレーションを行います。追加機能として、内部ソフトスタート回路による突入電流の低減、パルス単位の電流制限、サーマル・シャットダウン、出力過電圧保護が搭載されています。

製品情報⁽¹⁾

型番	パッケージ	本体サイズ(公称)
LMR10520	WSO _N (6)	3.00mm×3.00mm

(1) 提供されているすべてのパッケージについては、巻末の注文情報を参照してください。

代表的なアプリケーション

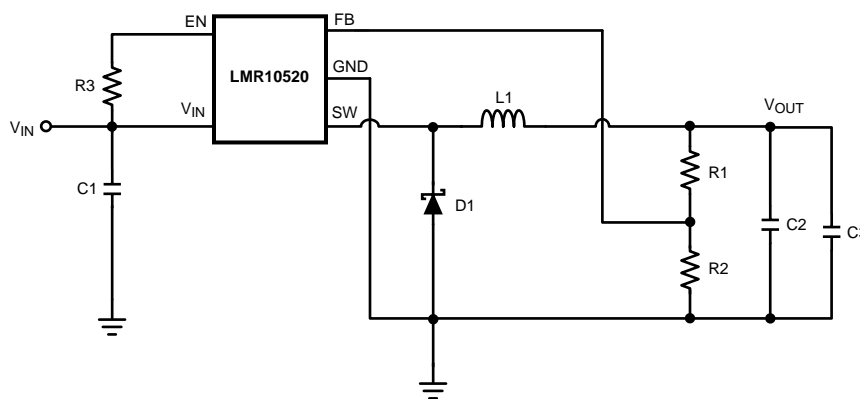

目次

1	特長	1	8.1	Application Information.....	11
2	アプリケーション	1	8.2	Typical Application	11
3	概要	1	9	Layout	19
4	改訂履歴.....	2	9.1	Layout Guidelines	19
5	Pin Configuration and Functions	3	9.2	Layout Example	19
6	Specifications.....	4	9.3	Thermal Definitions	20
6.1	Absolute Maximum Ratings	4	9.4	WSON Package	21
6.2	Recommended Operating Ratings.....	4	10	デバイスおよびドキュメントのサポート	22
6.3	Electrical Characteristics.....	5	10.1	デバイス・サポート.....	22
6.4	Typical Characteristics	6	10.2	ドキュメントの更新通知を受け取る方法.....	22
7	Detailed Description	8	10.3	コミュニティ・リソース	22
7.1	Overview	8	10.4	商標.....	22
7.2	Functional Block Diagram	9	10.5	静電気放電に関する注意事項	22
7.3	Feature Description.....	10	10.6	Glossary	23
8	Application and Implementation	11	11	メカニカル、パッケージ、および注文情報	23

4 改訂履歴

資料番号末尾の英字は改訂を表しています。その改訂履歴は英語版に準じています。

Revision B (April 2013) から Revision C に変更

Page

- 編集上の変更のみ、WEBENCH へのリンクを追加

1

Revision A (April 2013) から Revision B に変更

Page

- ナショナル セミコンダクターのデータシートのレイアウトを TI フォーマットに 変更

1

5 Pin Configuration and Functions

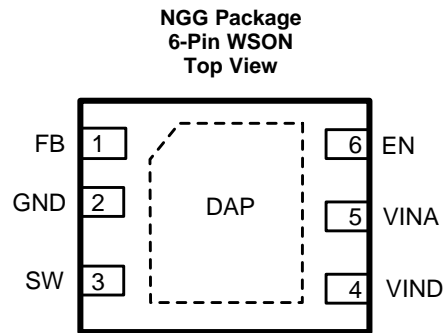

Pin Descriptions

PIN		DESCRIPTION
NO.	NAME	
1	FB	Feedback pin. Connect to external resistor divider to set output voltage.
2	GND	Signal and power ground pin. Place the bottom resistor of the feedback network as close as possible to this pin.
3	SW	Switch node. Connect to the inductor and catch diode.
4	VIND	Power input supply.
5	VINA	Control circuitry supply voltage. Connect VINA to VIND on PC board.
6	EN	Enable control input. Logic high enables operation. Do not allow this pin to float or be greater than VINA + 0.3 V.
DAP	Die Attach Pad	Connect to system ground for low thermal impedance, but it cannot be used as a primary GND connection.

6 Specifications

6.1 Absolute Maximum Ratings

 See ⁽¹⁾⁽²⁾.

VIN	-0.5V to 7V
FB Voltage	-0.5V to 3V
EN Voltage	-0.5V to 7V
SW Voltage	-0.5V to 7V
ESD Susceptibility	2kV
Junction Temperature ⁽³⁾	150°C
Storage Temperature	-65°C to +150°C
Soldering Information	
For soldering specifications: http://www.ti.com/lit/SNOA549	

- (1) If Military/Aerospace specified devices are required, contact the Texas Instruments Sales Office/ Distributors for availability and specifications.
- (2) Absolute maximum ratings indicate limits beyond which damage to the device may occur. Operating Range indicates conditions for which the device is intended to be functional, but does not ensure specific performance limits. For ensured specifications and test conditions, see [Electrical Characteristics](#).
- (3) Thermal shutdown occurs if the junction temperature exceeds the maximum junction temperature of the device.

6.2 Recommended Operating Ratings

VIN	3V to 5.5V
Junction Temperature	-40°C to +125°C

6.3 Electrical Characteristics

$V_{IN} = 5\text{ V}$ unless otherwise indicated under the **TEST CONDITIONS** column. Limits in standard type are for $T_J = 25^\circ\text{C}$ only; limits in **boldface type** apply over the junction temperature (T_J) range of -40°C to $+125^\circ\text{C}$. Minimum and Maximum limits are ensured through test, design, or statistical correlation. Typical values represent the most likely parametric norm at $T_J = 25^\circ\text{C}$, and are provided for reference purposes only. ⁽¹⁾⁽²⁾

PARAMETER		TEST CONDITIONS	MIN	TYP	MAX	UNIT
V_{FB}	Feedback Voltage		0.588	0.600	0.612	V
$\Delta V_{FB}/V_{IN}$	Feedback Voltage Line Regulation	$V_{IN} = 3\text{V to }5\text{V}$		0.02		%/V
I_B	Feedback Input Bias Current			0.1	100	nA
UVLO	Undervoltage Lockout	V_{IN} Rising		2.73	2.90	V
		V_{IN} Falling	1.85	2.3		
	UVLO Hysteresis			0.43		V
F_{SW}	Switching Frequency	LMR10520-X	1.2	1.6	1.95	MHz
		LMR10520-Y	2.25	3.0	3.75	
D_{MAX}	Maximum Duty Cycle	LMR10520-X	86%	94%		
		LMR10520-Y	82%	90%		
D_{MIN}	Minimum Duty Cycle	LMR10520-X		5%		
		LMR10520-Y		7%		
$R_{DS(ON)}$	Switch On Resistance			150		m Ω
I_{CL}	Switch Current Limit	$V_{IN} = 3.3\text{V}$	2.4	3.25		A
V_{EN_TH}	Shutdown Threshold Voltage				0.4	V
	Enable Threshold Voltage		1.8			
I_{SW}	Switch Leakage			100		nA
I_{EN}	Enable Pin Current	Sink/Source		100		nA
I_Q	Quiescent Current (switching)	LMR10520X $V_{FB} = 0.55$		3.3	5	mA
		LMR10520Y $V_{FB} = 0.55$		4.3	6.5	
	Quiescent Current (shutdown)	All Options $V_{EN} = 0\text{V}$		30		nA
θ_{JA}	Junction to Ambient 0 LFPM Air Flow ⁽³⁾			80		$^\circ\text{C/W}$
θ_{JC}	Junction to Case			18		$^\circ\text{C/W}$
T_{SD}	Thermal Shutdown Temperature			165		$^\circ\text{C}$

- (1) Minimum and Maximum limits are 100% production tested at 25°C . Limits over the operating temperature range are specified through correlation using Statistical Quality Control (SQC) methods. Limits are used to calculate Average Outgoing Quality Level (AOQL).
- (2) Typical numbers are at 25°C and represent the most likely parametric norm.
- (3) Applies for packages soldered directly onto a $3'' \times 3''$ PC board with 2 oz. copper on 4 layers in still air.

6.4 Typical Characteristics

Unless stated otherwise, all curves taken at $V_{IN} = 5\text{ V}$ with configuration in typical application circuit shown in Figure 14. $T_J = 25^\circ\text{C}$, unless otherwise specified.

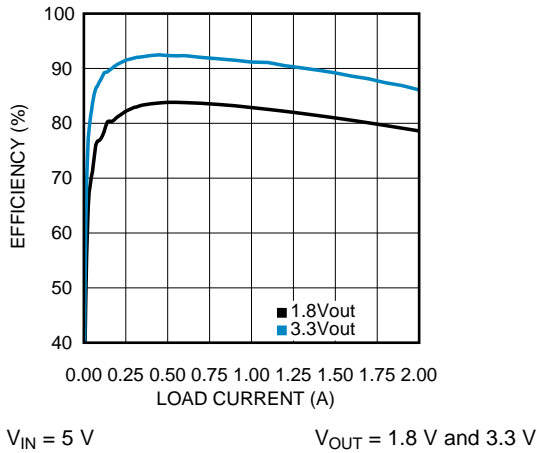

Figure 1. Efficiency vs Load "X"

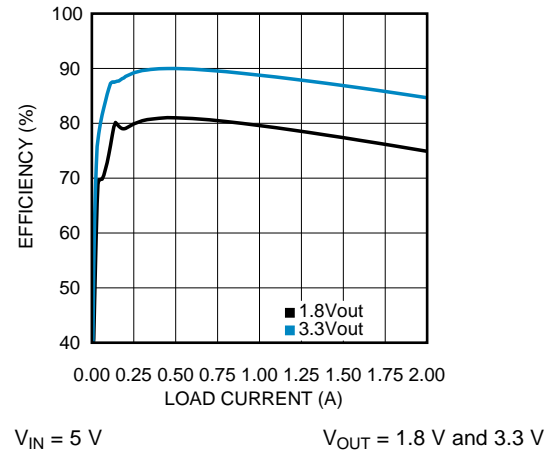

Figure 2. Efficiency vs Load "Y"

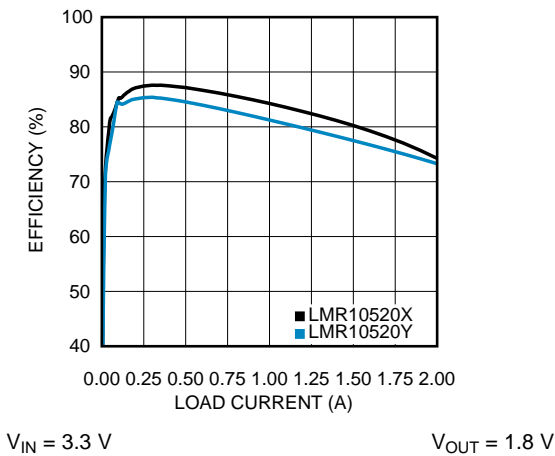

Figure 3. Efficiency vs Load "X" and "Y"

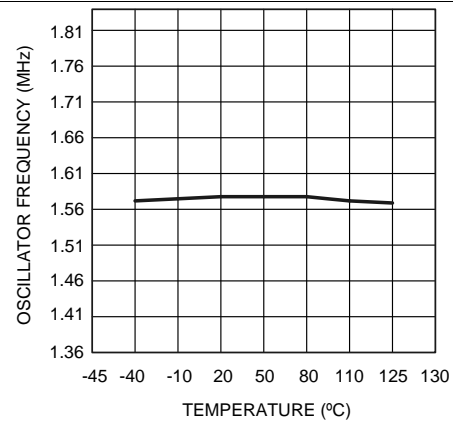

Figure 4. Oscillator Frequency vs Temperature - "X"

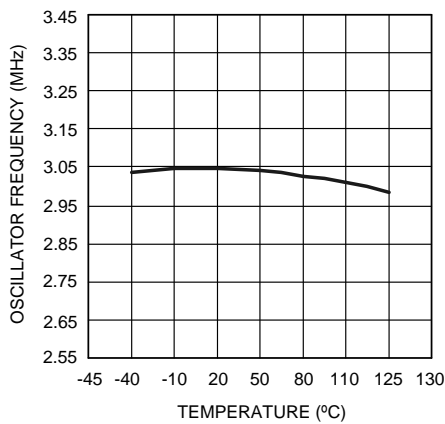

Figure 5. Oscillator Frequency vs Temperature - "Y"

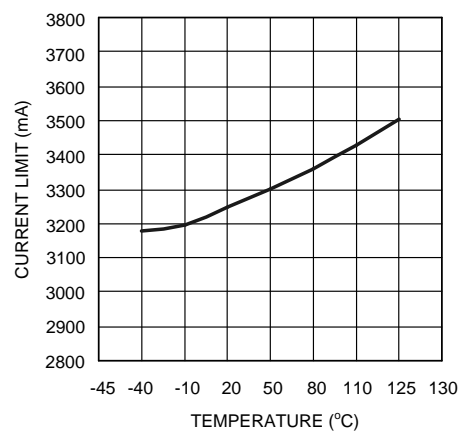

Figure 6. Current Limit vs Temperature

Typical Characteristics (continued)

Unless stated otherwise, all curves taken at $V_{IN} = 5\text{ V}$ with configuration in typical application circuit shown in Figure 14.

$T_j = 25^\circ\text{C}$, unless otherwise specified.

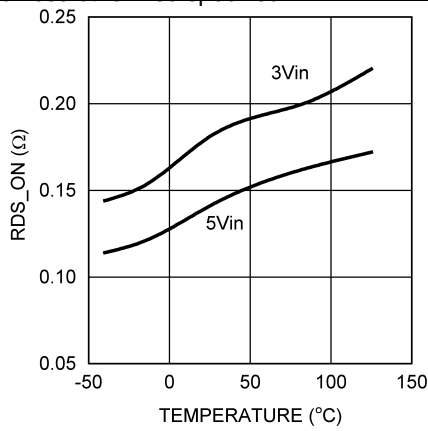

Figure 7. $R_{DS(ON)}$ vs Temperature

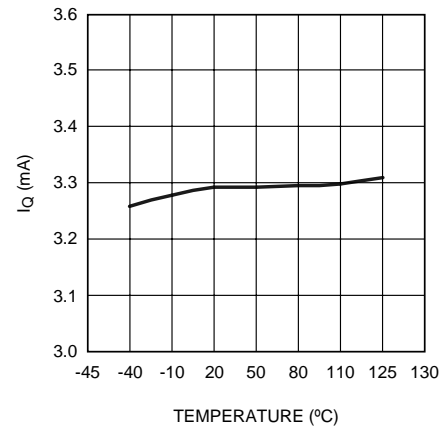

Figure 8. LMR10520X I_Q (Quiescent Current)

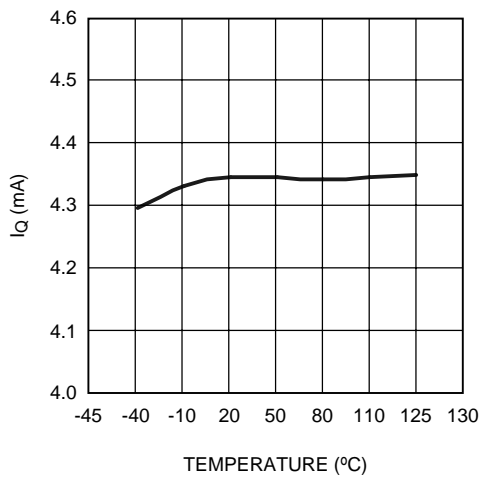

Figure 9. LMR10520Y I_Q (Quiescent Current)

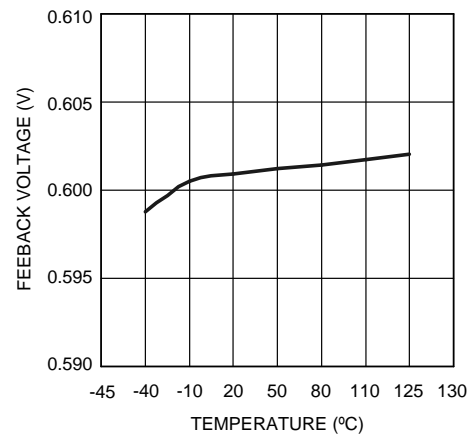

Figure 10. V_{FB} vs Temperature

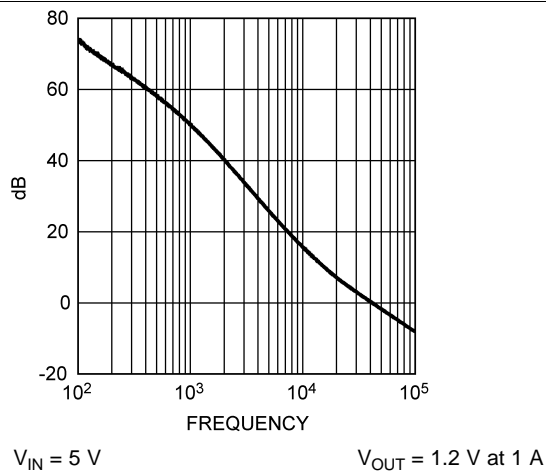

Figure 11. Gain vs Frequency

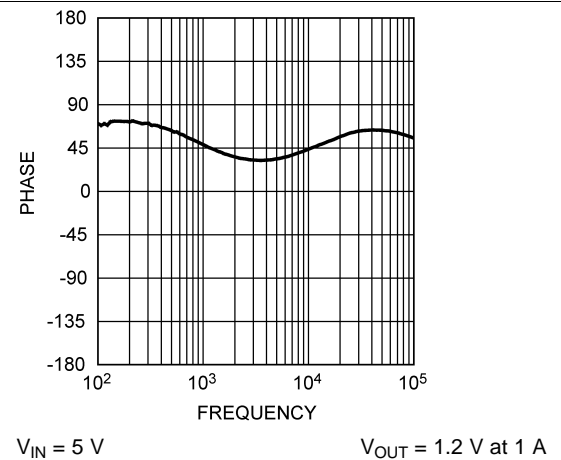

Figure 12. Phase Plot vs Frequency

7 Detailed Description

7.1 Overview

The following operating description of the LMR10520 refers to [Functional Block Diagram](#) and to the waveforms in [Figure 13](#). The LMR10520 supplies a regulated output voltage by switching the internal PMOS control switch at constant frequency and variable duty cycle. A switching cycle begins at the falling edge of the reset pulse generated by the internal oscillator. When this pulse goes low, the output control logic turns on the internal PMOS control switch. During this on-time, the SW pin voltage (V_{SW}) swings up to approximately V_{IN} , and the inductor current (I_L) increases with a linear slope. I_L is measured by the current sense amplifier, which generates an output proportional to the switch current. The sense signal is summed with the regulator's corrective ramp and compared to the error amplifier's output, which is proportional to the difference between the feedback voltage and V_{REF} . When the PWM comparator output goes high, the output switch turns off until the next switching cycle begins. During the switch off-time, inductor current discharges through the Schottky catch diode, which forces the SW pin to swing below ground by the forward voltage (V_D) of the Schottky catch diode. The regulator loop adjusts the duty cycle (D) to maintain a constant output voltage.

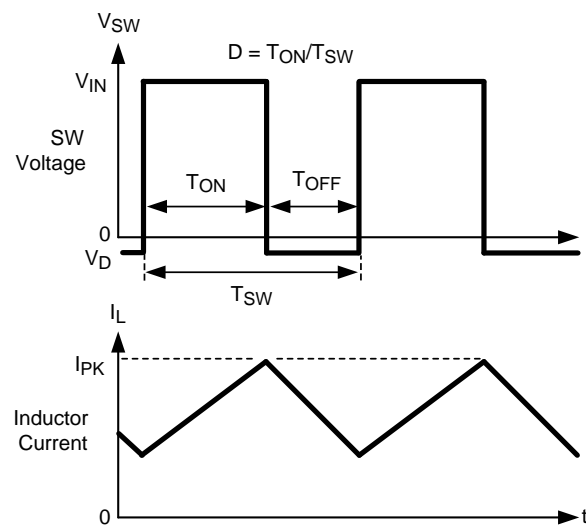
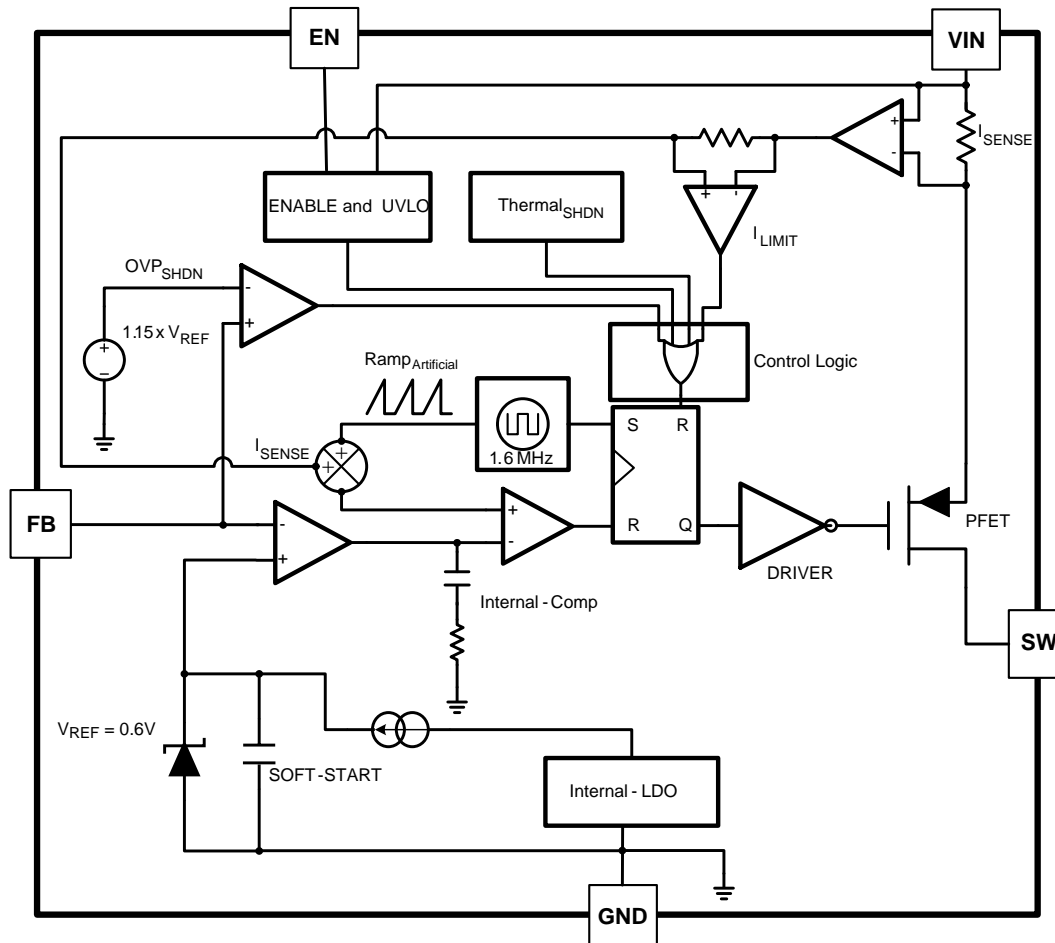

Figure 13. Typical Waveforms

7.2 Functional Block Diagram



7.3 Feature Description

7.3.1 Soft-Start

This function forces V_{OUT} to increase at a controlled rate during start-up. During soft start, the error amplifier's reference voltage ramps from 0 V to its nominal value of 0.6 V in approximately 600 μ s. This forces the regulator output to ramp up in a controlled fashion, which helps reduce inrush current.

7.3.2 Output Overvoltage Protection

The overvoltage comparator compares the FB pin voltage to a voltage that is 15% higher than the internal reference V_{REF} . Once the FB pin voltage goes 15% above the internal reference, the internal PMOS control switch is turned off, which allows the output voltage to decrease toward regulation.

7.3.3 Undervoltage Lockout

Undervoltage lockout (UVLO) prevents the LMR10520 from operating until the input voltage exceeds 2.73 V (typical). The UVLO threshold has approximately 430 mV of hysteresis, so the part will operate until V_{IN} drops below 2.3 V (typical). Hysteresis prevents the part from turning off during power-up if V_{IN} is non-monotonic.

7.3.4 Current Limit

The LMR10520 uses cycle-by-cycle current limiting to protect the output switch. During each switching cycle, a current limit comparator detects if the output switch current exceeds 2.5 A (typical), and turns off the switch until the next switching cycle begins.

7.3.5 Thermal Shutdown

Thermal shutdown limits total power dissipation by turning off the output switch when the IC junction temperature exceeds 165°C. After thermal shutdown occurs, the output switch doesn't turn on until the junction temperature drops to approximately 150°C.

8 Application and Implementation

NOTE

Information in the following applications sections is not part of the TI component specification, and TI does not warrant its accuracy or completeness. TI's customers are responsible for determining suitability of components for their purposes. Customers should validate and test their design implementation to confirm system functionality.

8.1 Application Information

The LMR10520 is internally compensated, so it is simple to use and requires few external components. The regulator has a preset switching frequency of 1.6 MHz or 3 MHz. This high frequency allows the LMR10520 to operate with small surface mount capacitors and inductors, resulting in a DC/DC converter that requires a minimum amount of board space

8.2 Typical Application

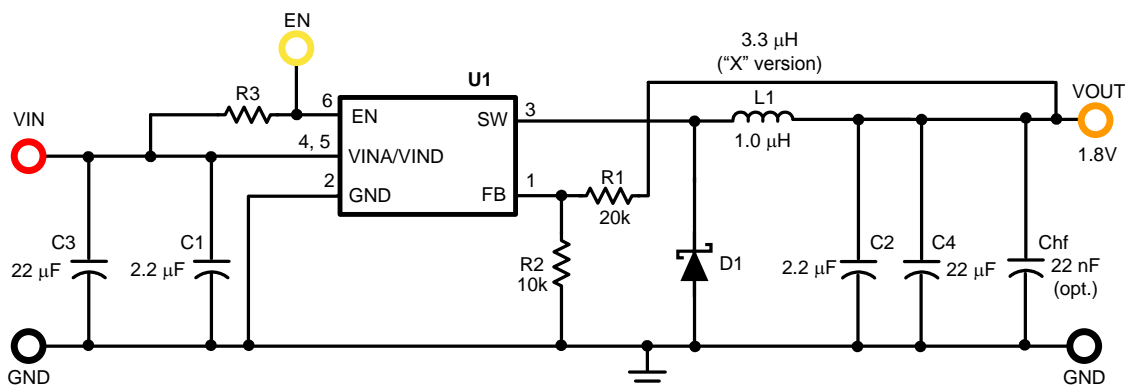

Figure 14. Typical Application Schematic

8.2.1 Detailed Design Procedure

8.2.1.1 Custom Design With WEBENCH® Tools

[Click here](#) to create a custom design using the LMR10520 device with the WEBENCH® Power Designer.

1. Start by entering the input voltage (V_{IN}), output voltage (V_{OUT}), and output current (I_{OUT}) requirements.
2. Optimize the design for key parameters such as efficiency, footprint, and cost using the optimizer dial.
3. Compare the generated design with other possible solutions from Texas Instruments.

The WEBENCH Power Designer provides a customized schematic along with a list of materials with real-time pricing and component availability.

In most cases, these actions are available:

- Run electrical simulations to see important waveforms and circuit performance
- Run thermal simulations to understand board thermal performance
- Export customized schematic and layout into popular CAD formats
- Print PDF reports for the design, and share the design with colleagues

Get more information about WEBENCH tools at www.ti.com/WBENCH.

Typical Application (continued)

8.2.1.2 Inductor Selection

The duty cycle (D) can be approximated quickly using the ratio of output voltage (V_O) to input voltage (V_{IN}):

The catch diode (D1) forward-voltage drop and the voltage drop across the internal PMOS must be included to calculate a more accurate duty cycle. Calculate D by using the following formula:

$$D = \frac{V_{OUT} + V_D}{V_{IN} + V_D - V_{SW}} \tag{1}$$

V_{SW} can be approximated by:

$$V_{SW} = I_{OUT} \times R_{DS(ON)} \tag{2}$$

The diode forward drop (V_D) can range from 0.3 V to 0.7 V depending on the quality of the diode. The lower the V_D, the higher the operating efficiency of the converter. The inductor value determines the output ripple current. Lower inductor values decrease the size of the inductor, but increase the output ripple current. An increase in the inductor value will decrease the output ripple current.

One must ensure that the minimum current limit (2.4A) is not exceeded, so the peak current in the inductor must be calculated. The peak current (I_{LPK}) in the inductor is calculated by:

$$I_{LPK} = I_{OUT} + \Delta i_L \tag{3}$$

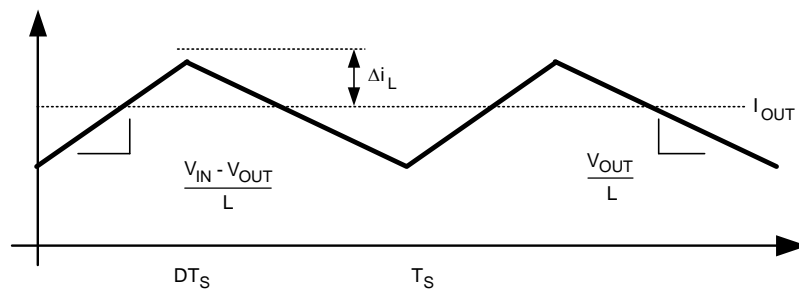

Figure 15. Inductor Current

$$\frac{V_{IN} - V_{OUT}}{L} = \frac{2\Delta i_L}{DT_S} \tag{4}$$

In general,

$$\Delta i_L = 0.1 \times (I_{OUT}) \rightarrow 0.2 \times (I_{OUT}) \tag{5}$$

If Δi_L = 20% of 2 A, the peak current in the inductor will be 2.4A. The minimum ensured current limit over all operating conditions is 2.4 A. One can either reduce Δi_L, or make the engineering judgment that zero margin will be safe enough. The typical current limit is 3.25 A.

The LMR10520 operates at frequencies allowing the use of ceramic output capacitors without compromising transient response. Ceramic capacitors allow higher inductor ripple without significantly increasing output ripple. See the [Output Capacitor](#) section for more details on calculating output voltage ripple. Now that the ripple current is determined, the inductance is calculated by:

$$L = \left(\frac{DT_S}{2\Delta i_L} \right) \times (V_{IN} - V_{OUT})$$

where

$$T_S = \frac{1}{f_S} \tag{7}$$

Typical Application (continued)

When selecting an inductor, make sure that it is capable of supporting the peak output current without saturating. Inductor saturation will result in a sudden reduction in inductance and prevent the regulator from operating correctly. Because of the speed of the internal current limit, the peak current of the inductor need only be specified for the required maximum output current. For example, if the designed maximum output current is 1 A, and the peak current is 1.25 A, then the inductor should be specified with a saturation current limit of > 1.25 A. There is no need to specify the saturation or peak current of the inductor at the 3.25 A typical switch current limit. The difference in inductor size is a factor of 5. Because of the operating frequency of the LMR10520, ferrite based inductors are preferred to minimize core losses. This presents little restriction since the variety of ferrite-based inductors is huge. Lastly, inductors with lower series resistance (R_{DCR}) will provide better operating efficiency. For recommended inductors, see [Other System Examples](#).

8.2.1.3 Input Capacitor

An input capacitor is necessary to ensure that V_{IN} does not drop excessively during switching transients. The primary specifications of the input capacitor are capacitance, voltage, RMS current rating, and equivalent series inductance (ESL). The recommended input capacitance is 22 μ F. The input voltage rating is specifically stated by the capacitor manufacturer. Make sure to check any recommended deratings and also verify if there is any significant change in capacitance at the operating input voltage and the operating temperature. The input capacitor maximum RMS input current rating (I_{RMS_IN}) must be greater than:

$$I_{RMS_IN} \sqrt{D \left[I_{OUT}^2 (1-D) + \frac{\Delta i^2}{3} \right]} \quad (8)$$

Neglecting inductor ripple simplifies the above equation to:

$$I_{RMS_IN} = I_{OUT} \times \sqrt{D(1 - D)} \quad (9)$$

It can be shown from the above equation that maximum RMS capacitor current occurs when $D = 0.5$. Always calculate the RMS at the point where the duty cycle D is closest to 0.5. The ESL of an input capacitor is usually determined by the effective cross sectional area of the current path. A large leaded capacitor will have high ESL and a 0805 ceramic chip capacitor will have very low ESL. At the operating frequencies of the LMR10520, leaded capacitors may have an ESL so large that the resulting impedance ($2\pi fL$) will be higher than that required to provide stable operation. As a result, surface mount capacitors are strongly recommended.

Sanyo POSCAP, Tantalum or Niobium, Panasonic SP, and multilayer ceramic capacitors (MLCC) are all good choices for both input and output capacitors and have very low ESL. For MLCCs it is recommended to use X7R or X5R type capacitors due to their tolerance and temperature characteristics. Consult capacitor manufacturer datasheets to see how rated capacitance varies over operating conditions.

8.2.1.4 Output Capacitor

The output capacitor is selected based upon the desired output ripple and transient response. The initial current of a load transient is provided mainly by the output capacitor. The output ripple of the converter is:

$$\Delta V_{OUT} = \Delta I_L \left(R_{ESR} + \frac{1}{8 \times F_{SW} \times C_{OUT}} \right) \quad (10)$$

When using MLCCs, the ESR is typically so low that the capacitive ripple may dominate. When this occurs, the output ripple will be approximately sinusoidal and 90° phase shifted from the switching action. Given the availability and quality of MLCCs and the expected output voltage of designs using the LMR10520, there is really no need to review any other capacitor technologies. Another benefit of ceramic capacitors is their ability to bypass high frequency noise. A certain amount of switching edge noise will couple through parasitic capacitances in the inductor to the output. A ceramic capacitor will bypass this noise while a tantalum will not. Since the output capacitor is one of the two external components that control the stability of the regulator control loop, most applications will require a minimum of 22 μ F of output capacitance. Capacitance often, but not always, can be increased significantly with little detriment to the regulator stability. Like the input capacitor, recommended multilayer ceramic capacitors are X7R or X5R types.

Typical Application (continued)

8.2.1.5 Catch Diode

The catch diode (D1) conducts during the switch off-time. A Schottky diode is recommended for its fast switching times and low forward voltage drop. The catch diode should be chosen so that its current rating is greater than:

$$I_{D1} = I_{OUT} \times (1-D) \quad (11)$$

The reverse breakdown rating of the diode must be at least the maximum input voltage plus appropriate margin. To improve efficiency, choose a Schottky diode with a low forward voltage drop.

8.2.1.6 Output Voltage

The output voltage is set using the following equation where R2 is connected between the FB pin and GND, and R1 is connected between V_O and the FB pin. A good value for R2 is 10kΩ. When designing a unity gain converter (V_O = 0.6V), R1 should be between 0Ω and 100Ω, and R2 should be equal or greater than 10kΩ.

$$R1 = \left(\frac{V_{OUT}}{V_{REF}} - 1 \right) \times R2 \quad (12)$$

$$V_{REF} = 0.60V \quad (13)$$

8.2.1.7 Calculating Efficiency and Junction Temperature

The complete LMR10520 DC/DC converter efficiency can be calculated in the following manner.

$$\eta = \frac{P_{OUT}}{P_{IN}} \quad (14)$$

Or

$$\eta = \frac{P_{OUT}}{P_{OUT} + P_{LOSS}} \quad (15)$$

Calculations for determining the most significant power losses are shown below. Other losses totaling less than 2% are not discussed.

Power loss (P_{LOSS}) is the sum of two basic types of losses in the converter: switching and conduction. Conduction losses usually dominate at higher output loads, whereas switching losses remain relatively fixed and dominate at lower output loads. The first step in determining the losses is to calculate the duty cycle (D):

$$D = \frac{V_{OUT} + V_D}{V_{IN} + V_D - V_{SW}} \quad (16)$$

V_{SW} is the voltage drop across the internal PFET when it is on, and is equal to:

$$V_{SW} = I_{OUT} \times R_{DSON} \quad (17)$$

V_D is the forward voltage drop across the Schottky catch diode. It can be obtained from the diode manufactures Electrical Characteristics section. If the voltage drop across the inductor (V_{DCR}) is accounted for, the equation becomes:

$$D = \frac{V_{OUT} + V_D + V_{DCR}}{V_{IN} + V_D + V_{DCR} - V_{SW}} \quad (18)$$

The conduction losses in the free-wheeling Schottky diode are calculated as follows:

$$P_{DIODE} = V_D \times I_{OUT} \times (1-D) \quad (19)$$

Often this is the single most significant power loss in the circuit. Care should be taken to choose a Schottky diode that has a low forward voltage drop.

Typical Application (continued)

Another significant external power loss is the conduction loss in the output inductor. The equation can be simplified to:

$$P_{IND} = I_{OUT}^2 \times R_{DCR} \quad (20)$$

The LMR10520 conduction loss is mainly associated with the internal PFET:

$$P_{COND} = (I_{OUT}^2 \times D) \left(1 + \frac{1}{3} \times \left(\frac{\Delta i_L}{I_{OUT}} \right)^2 \right) R_{DS(ON)} \quad (21)$$

If the inductor ripple current is fairly small, the conduction losses can be simplified to:

$$P_{COND} = I_{OUT}^2 \times R_{DS(ON)} \times D \quad (22)$$

Switching losses are also associated with the internal PFET. They occur during the switch on and off transition periods, where voltages and currents overlap resulting in power loss. The simplest means to determine this loss is to empirically measuring the rise and fall times (10% to 90%) of the switch at the switch node.

Switching Power Loss is calculated as follows:

$$P_{SWR} = 1/2(V_{IN} \times I_{OUT} \times F_{SW} \times T_{RISE}) \quad (23)$$

$$P_{SWF} = 1/2(V_{IN} \times I_{OUT} \times F_{SW} \times T_{FALL}) \quad (24)$$

$$P_{SW} = P_{SWR} + P_{SWF} \quad (25)$$

Another loss is the power required for operation of the internal circuitry:

$$P_Q = I_Q \times V_{IN} \quad (26)$$

I_Q is the quiescent operating current, and is typically around 3.3 mA for the 1.6-MHz frequency option.

Typical application power losses are:

Table 1. Power Loss Tabulation

V_{IN}	5 V		
V_{OUT}	3.3 V	P_{OUT}	5.78 W
I_{OUT}	1.75 A		
V_D	0.45 V	P_{DIODE}	262 mW
F_{SW}	1.6 MHz		
I_Q	3.3 mA	P_Q	16.5 mW
T_{RISE}	4 ns	P_{SWR}	28 mW
T_{FALL}	4 ns	P_{SWF}	28 mW
$R_{DS(ON)}$	150 m Ω	P_{COND}	306 mW
IND_{DCR}	50 m Ω	P_{IND}	153 mW
D	0.667	P_{LOSS}	794 mW
η	88%	$P_{INTERNAL}$	379 mW

$$\Sigma P_{COND} + P_{SW} + P_{DIODE} + P_{IND} + P_Q = P_{LOSS} \quad (27)$$

$$\Sigma P_{COND} + P_{SWF} + P_{SWR} + P_Q = P_{INTERNAL} \quad (28)$$

$$P_{INTERNAL} = 379\text{mW} \quad (29)$$

8.2.2 Application Curves

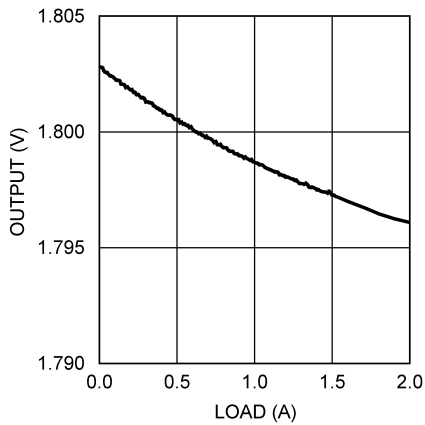

$V_{IN} = 3.3\text{ V}$ $V_{OUT} = 1.8\text{ V}$ (All Options)

Figure 16. Load Regulation

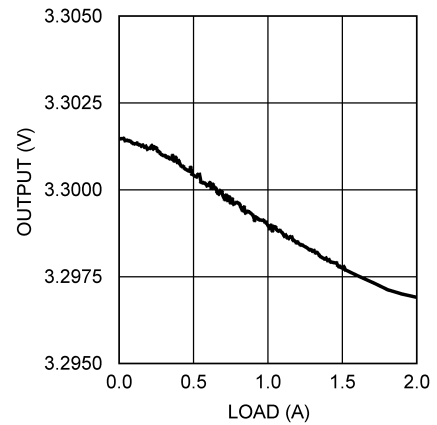

$V_{IN} = 3.3\text{ V}$ $V_{OUT} = 3.3\text{ V}$ (All Options)

Figure 17. Load Regulation

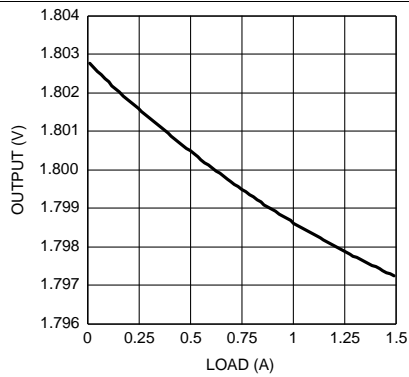
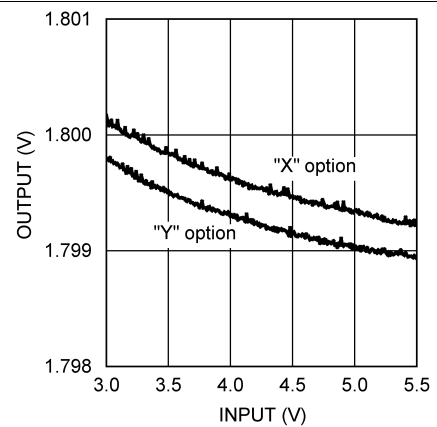

Figure 18. Load Regulation



$V_{OUT} = 1.8\text{ V}$ $I_{OUT} = 500\text{ mA}$

Figure 19. Line Regulation

8.2.3 Other System Examples

8.2.3.1 LMR10520X Design Example 1

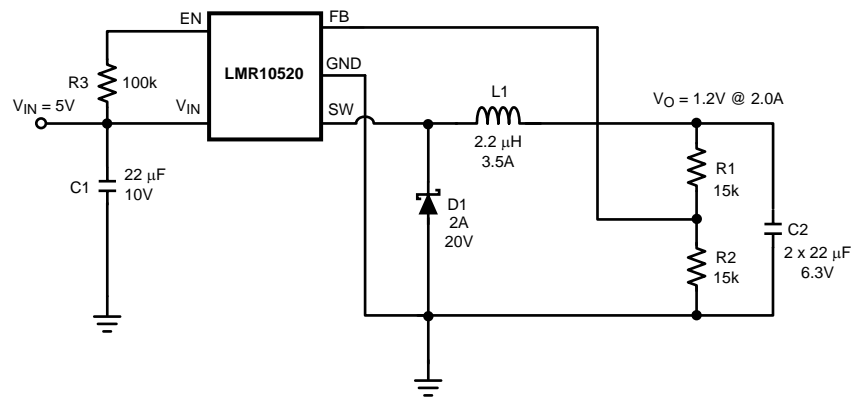

Figure 20. LMR10520x (1.6 MHz): $V_{IN} = 5\text{ V}$, $V_{OUT} = 1.2\text{ V}$ at 2 A

8.2.3.2 LMR10510X Design Example 2

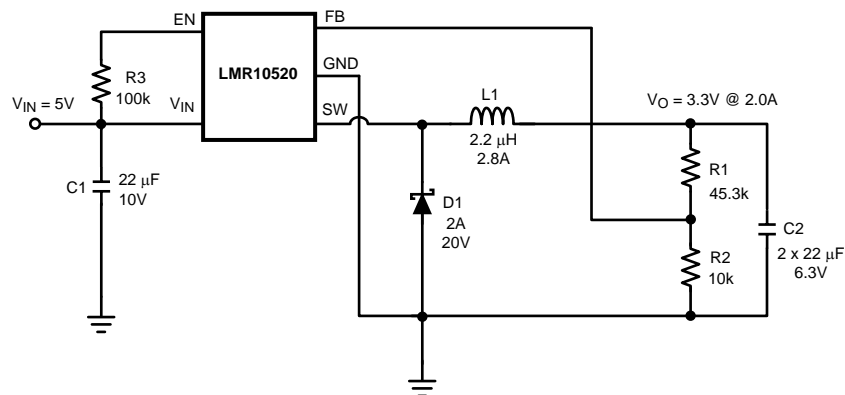
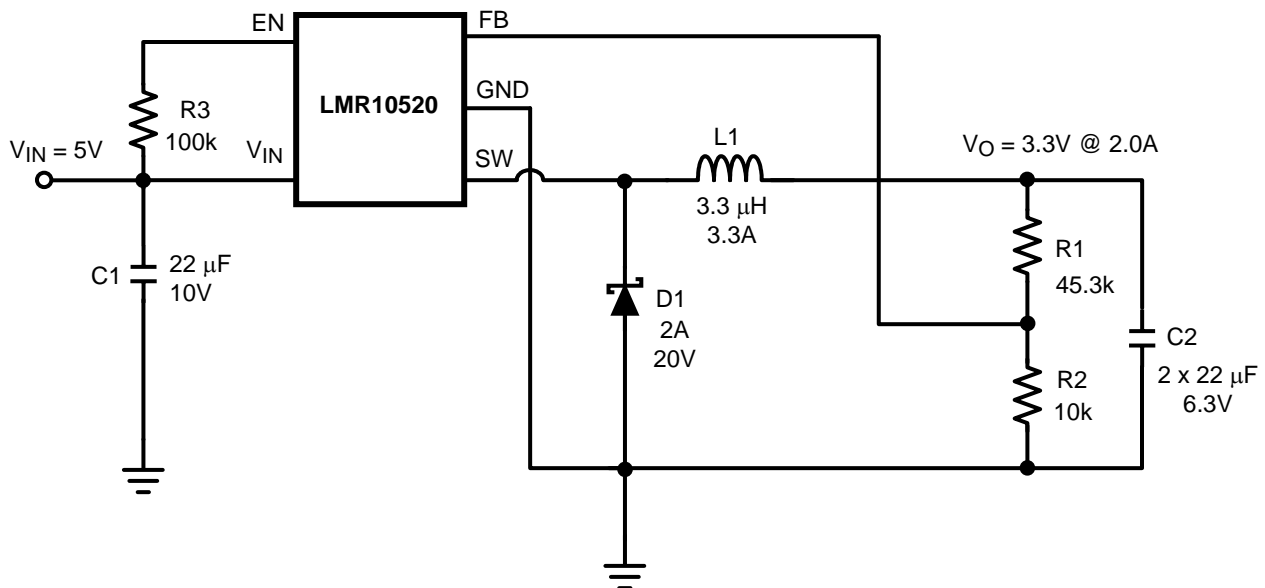
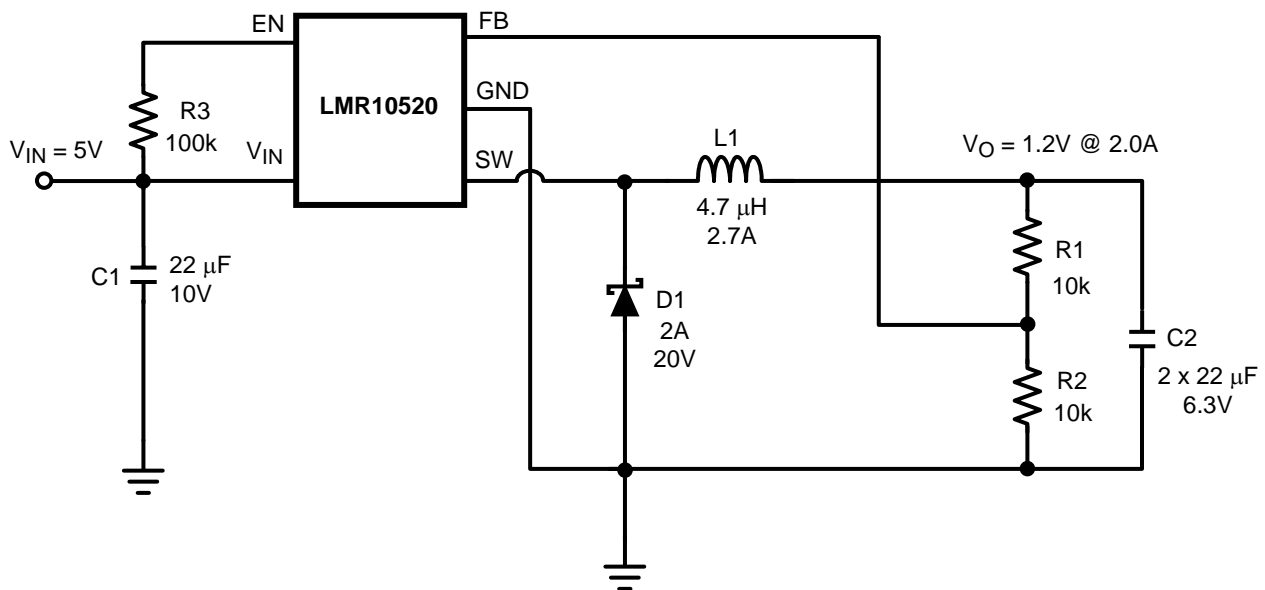

Figure 21. LMR10520X (1.6 MHz): $V_{IN} = 5\text{ V}$, $V_{OUT} = 3.3\text{ V}$ at 2 A

LMR10520

JAJSHK5C –OCTOBER 2011–REVISED JUNE 2019

www.ti.com
8.2.3.3 LMR10510Y Design Example 3

Figure 22. LMR10520Y (3 MHz): $V_{IN} = 5\text{ V}$, $V_{OUT} = 3.3\text{ V}$ at 2 A
8.2.3.4 LMR10510Y Design Example 4

Figure 23. LMR10520Y (3 MHz): $V_{IN} = 5\text{ V}$, $V_{OUT} = 1.2\text{ V}$ at 2 A

9 Layout

9.1 Layout Guidelines

When planning layout there are a few things to consider when trying to achieve a clean, regulated output. The most important consideration is the close coupling of the GND connections of the input capacitor and the catch diode D1. Place these ground ends close to one another and be connected to the GND plane with at least two through-holes. Place these components as close to the IC as possible. Next in importance is the location of the GND connection of the output capacitor, which should be near the GND connections of CIN and D1. There should be a continuous ground plane on the bottom layer of a two-layer board except under the switching node island. The FB pin is a high impedance node and care should be taken to make the FB trace short to avoid noise pickup and inaccurate regulation. Place the feedback resistors as close as possible to the IC, with the GND of R1 placed as close as possible to the GND of the IC. Route the V_{OUT} trace to R2 away from the inductor and any other traces that are switching. High AC currents flow through the V_{IN} , SW and V_{OUT} traces, so they should be as short and wide as possible. However, making the traces wide increases radiated noise, so the designer must make this trade-off. Radiated noise can be decreased by choosing a shielded inductor. The remaining components should also be placed as close as possible to the IC. See

[Application Note AN-1229](#) for further considerations and the LMR10520 demo board as an example of a good layout.

9.2 Layout Example

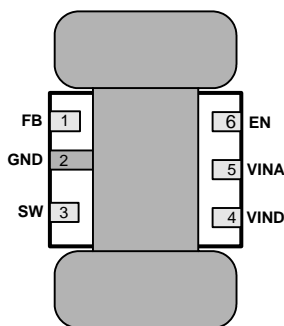

Figure 24. 6-Lead WSON PCB Dog-Bone Layout

9.3 Thermal Definitions

T_J = Chip junction temperature

T_A = Ambient temperature

$R_{\theta JC}$ = Thermal resistance from chip junction to device case

$R_{\theta JA}$ = Thermal resistance from chip junction to ambient air

Heat in the LMR10520 due to internal power dissipation is removed through conduction and/or convection.

Conduction: Heat transfer occurs through cross sectional areas of material. Depending on the material, the transfer of heat can be considered to have poor to good thermal conductivity properties (insulator vs. conductor).

Heat Transfer goes as:

Silicon → package → lead frame → PCB

Convection: Heat transfer is by means of airflow. This could be from a fan or natural convection. Natural convection occurs when air currents rise from the hot device to cooler air.

Thermal impedance is defined as:

$$R_{\theta} = \frac{\Delta T}{\text{Power}} \quad (30)$$

Thermal impedance from the silicon junction to the ambient air is defined as:

$$R_{\theta JA} = \frac{T_J - T_A}{\text{Power}} \quad (31)$$

The PCB size, weight of copper used to route traces and ground plane, and number of layers within the PCB can greatly effect $R_{\theta JA}$. The type and number of thermal vias can also make a large difference in the thermal impedance. Thermal vias are necessary in most applications. They conduct heat from the surface of the PCB to the ground plane. Four to six thermal vias should be placed under the exposed pad to the ground plane.

Thermal impedance also depends on the thermal properties of the application operating conditions (V_{in} , V_o , I_o etc), and the surrounding circuitry.

Silicon Junction Temperature Determination Method 1:

To accurately measure the silicon temperature for a given application, two methods can be used. The first method requires the user to know the thermal impedance of the silicon junction to case temperature.

$R_{\theta JC}$ is approximately 18°C/Watt for the 6-pin WSON package with the exposed pad. Knowing the internal dissipation from the efficiency calculation given previously, and the case temperature, which can be empirically measured on the bench we have:

$$R_{\theta JC} = \frac{T_J - T_C}{\text{Power}}$$

where

- T_C is the temperature of the exposed pad and can be measured on the bottom side of the PCB. (32)

Therefore:

$$T_J = (R_{\theta JC} \times P_{\text{LOSS}}) + T_C \quad (33)$$

From the previous example:

$$T_J = (R_{\theta JC} \times P_{\text{INTERNAL}}) + T_C \quad (34)$$

$$T_J = 18^{\circ}\text{C/W} \times 0.213\text{W} + T_C \quad (35)$$

The second method can give a very accurate silicon junction temperature.

Thermal Definitions (continued)

The first step is to determine $R_{\theta JA}$ of the application. The LMR10520 has over-temperature protection circuitry. When the silicon temperature reaches 165°C, the device stops switching. The protection circuitry has a hysteresis of about 15°C. Once the silicon temperature has decreased to approximately 150°C, the device will start to switch again. Knowing this, the $R_{\theta JA}$ for any application can be characterized during the early stages of the design one may calculate the $R_{\theta JA}$ by placing the PCB circuit into a thermal chamber. Raise the ambient temperature in the given working application until the circuit enters thermal shutdown. If the SW-pin is monitored, it will be obvious when the internal PFET stops switching, indicating a junction temperature of 165°C. Knowing the internal power dissipation from the above methods, the junction temperature, and the ambient temperature $R_{\theta JA}$ can be determined.

$$R_{\theta JA} = \frac{165^{\circ} - T_a}{P_{INTERNAL}} \tag{36}$$

Once this is determined, the maximum ambient temperature allowed for a desired junction temperature can be found.

An example of calculating $R_{\theta JA}$ for an application using the LMR10520 is shown below.

A sample PCB is placed in an oven with no forced airflow. The ambient temperature was raised to 120°C, and at that temperature, the device went into thermal shutdown.

From the previous example:

$$P_{INTERNAL} = 379 \text{ mW} \tag{37}$$

$$R_{\theta JA} = \frac{165^{\circ}\text{C} - 120^{\circ}\text{C}}{379 \text{ mW}} = 119^{\circ}\text{C/W} \tag{38}$$

Since the junction temperature must be kept below 125°C, then the maximum ambient temperature can be calculated as:

$$T_j - (R_{\theta JA} \times P_{LOSS}) = T_a \tag{39}$$

$$125^{\circ}\text{C} - (119^{\circ}\text{C/W} \times 379 \text{ mW}) = 80^{\circ}\text{C} \tag{40}$$

9.4 WSON Package

For certain high power applications, the PCB land may be modified to a "dog bone" shape (see [Figure 24](#)). By increasing the size of ground plane, and adding thermal vias, the $R_{\theta JA}$ for the application can be reduced.

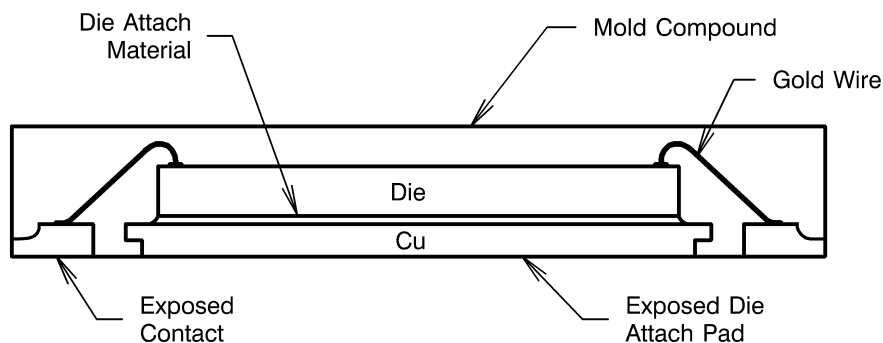

Figure 25. Internal WSON Connection

10 デバイスおよびドキュメントのサポート

10.1 デバイス・サポート

10.1.1 デベロッパー・ネットワークの製品に関する免責事項

デベロッパー・ネットワークの製品またはサービスに関するTIの出版物は、単独またはTIの製品、サービスと一緒に提供される場合に関係なく、デベロッパー・ネットワークの製品またはサービスの適合性に関する是認、デベロッパー・ネットワークの製品またはサービスの是認の表明を意味するものではありません。

10.1.2 開発サポート

10.1.2.1 WEBENCH®ツールによるカスタム設計

[ここをクリック](#)すると、WEBENCH® Power Designerにより、LMR10520 デバイスを使用するカスタム設計を作成できます。

1. 最初に、入力電圧(V_{IN})、出力電圧(V_{OUT})、出力電流(I_{OUT})の要件を入力します。
2. オプティマイザのダイヤルを使用して、効率、占有面積、コストなどの主要なパラメータについて設計を最適化します。
3. 生成された設計を、テキサス・インスツルメンツが提供する他の方式と比較します。

WEBENCH Power Designerでは、カスタマイズされた回路図と部品リストを、リアルタイムの価格と部品の在庫情報と併せて参照できます。

通常、次の操作を実行可能です。

- 電氣的なシミュレーションを実行し、重要な波形と回路の性能を確認する。
- 熱シミュレーションを実行し、基板の熱特性を把握する。
- カスタマイズされた回路図やレイアウトを、一般的なCADフォーマットで出力する。
- 設計のレポートをPDFで印刷し、設計を共有する。

WEBENCHツールの詳細は、www.ti.com/WEBENCHでご覧になれます。

10.2 ドキュメントの更新通知を受け取る方法

ドキュメントの更新についての通知を受け取るには、ti.comのデバイス製品フォルダを開いてください。右上の「アラートを受け取る」をクリックして登録すると、変更されたすべての製品情報に関するダイジェストを毎週受け取れます。変更の詳細については、修正されたドキュメントに含まれている改訂履歴をご覧ください。

10.3 コミュニティ・リソース

The following links connect to TI community resources. Linked contents are provided "AS IS" by the respective contributors. They do not constitute TI specifications and do not necessarily reflect TI's views; see TI's [Terms of Use](#).

TI E2E™ Online Community *TI's Engineer-to-Engineer (E2E) Community*. Created to foster collaboration among engineers. At e2e.ti.com, you can ask questions, share knowledge, explore ideas and help solve problems with fellow engineers.

Design Support *TI's Design Support* Quickly find helpful E2E forums along with design support tools and contact information for technical support.

10.4 商標

E2E is a trademark of Texas Instruments.

WEBENCH is a registered trademark of Texas Instruments.

All other trademarks are the property of their respective owners.

10.5 静電気放電に関する注意事項



すべての集積回路は、適切なESD保護方法を用いて、取扱いと保存を行うようにして下さい。

静電気放電はわずかな性能の低下から完全なデバイスの故障に至るまで、様々な損傷を与えます。高精度の集積回路は、損傷に対して敏感であり、極めてわずかなパラメータの変化により、デバイスに規定された仕様に適合しなくなる場合があります。

10.6 Glossary

[SLYZ022](#) — *TI Glossary*.

This glossary lists and explains terms, acronyms, and definitions.

11 メカニカル、パッケージ、および注文情報

以降のページには、メカニカル、パッケージ、および注文に関する情報が記載されています。この情報は、そのデバイスについて利用可能な最新のデータです。このデータは予告なく変更されることがあり、ドキュメントが改訂される場合もあります。本データシートのブラウザ版を使用されている場合は、画面左側の説明をご覧ください。

PACKAGING INFORMATION

Orderable Device	Status (1)	Package Type	Package Drawing	Pins	Package Qty	Eco Plan (2)	Lead finish/ Ball material (6)	MSL Peak Temp (3)	Op Temp (°C)	Device Marking (4/5)	Samples
LMR10520XSD/NOPB	ACTIVE	WSON	NGG	6	1000	RoHS & Green	SN	Level-3-260C-168 HR	-40 to 125	L266B	Samples
LMR10520XSDE/NOPB	ACTIVE	WSON	NGG	6	250	RoHS & Green	SN	Level-3-260C-168 HR	-40 to 125	L266B	Samples
LMR10520XSDX/NOPB	ACTIVE	WSON	NGG	6	4500	RoHS & Green	SN	Level-3-260C-168 HR	-40 to 125	L266B	Samples
LMR10520YSD/NOPB	ACTIVE	WSON	NGG	6	1000	RoHS & Green	SN	Level-3-260C-168 HR	-40 to 125	L267B	Samples
LMR10520YSDE/NOPB	ACTIVE	WSON	NGG	6	250	RoHS & Green	SN	Level-3-260C-168 HR	-40 to 125	L267B	Samples
LMR10520YSDX/NOPB	ACTIVE	WSON	NGG	6	4500	RoHS & Green	SN	Level-3-260C-168 HR	-40 to 125	L267B	Samples

(1) The marketing status values are defined as follows:

ACTIVE: Product device recommended for new designs.

LIFEBUY: TI has announced that the device will be discontinued, and a lifetime-buy period is in effect.

NRND: Not recommended for new designs. Device is in production to support existing customers, but TI does not recommend using this part in a new design.

PREVIEW: Device has been announced but is not in production. Samples may or may not be available.

OBSOLETE: TI has discontinued the production of the device.

(2) **RoHS:** TI defines "RoHS" to mean semiconductor products that are compliant with the current EU RoHS requirements for all 10 RoHS substances, including the requirement that RoHS substance do not exceed 0.1% by weight in homogeneous materials. Where designed to be soldered at high temperatures, "RoHS" products are suitable for use in specified lead-free processes. TI may reference these types of products as "Pb-Free".

RoHS Exempt: TI defines "RoHS Exempt" to mean products that contain lead but are compliant with EU RoHS pursuant to a specific EU RoHS exemption.

Green: TI defines "Green" to mean the content of Chlorine (Cl) and Bromine (Br) based flame retardants meet JS709B low halogen requirements of <=1000ppm threshold. Antimony trioxide based flame retardants must also meet the <=1000ppm threshold requirement.

(3) MSL, Peak Temp. - The Moisture Sensitivity Level rating according to the JEDEC industry standard classifications, and peak solder temperature.

(4) There may be additional marking, which relates to the logo, the lot trace code information, or the environmental category on the device.

(5) Multiple Device Markings will be inside parentheses. Only one Device Marking contained in parentheses and separated by a "~" will appear on a device. If a line is indented then it is a continuation of the previous line and the two combined represent the entire Device Marking for that device.

(6) Lead finish/Ball material - Orderable Devices may have multiple material finish options. Finish options are separated by a vertical ruled line. Lead finish/Ball material values may wrap to two lines if the finish value exceeds the maximum column width.

Important Information and Disclaimer: The information provided on this page represents TI's knowledge and belief as of the date that it is provided. TI bases its knowledge and belief on information provided by third parties, and makes no representation or warranty as to the accuracy of such information. Efforts are underway to better integrate information from third parties. TI has taken and continues to take reasonable steps to provide representative and accurate information but may not have conducted destructive testing or chemical analysis on incoming materials and chemicals. TI and TI suppliers consider certain information to be proprietary, and thus CAS numbers and other limited information may not be available for release.

In no event shall TI's liability arising out of such information exceed the total purchase price of the TI part(s) at issue in this document sold by TI to Customer on an annual basis.

TAPE AND REEL INFORMATION

QUADRANT ASSIGNMENTS FOR PIN 1 ORIENTATION IN TAPE

*All dimensions are nominal

Device	Package Type	Package Drawing	Pins	SPQ	Reel Diameter (mm)	Reel Width W1 (mm)	A0 (mm)	B0 (mm)	K0 (mm)	P1 (mm)	W (mm)	Pin1 Quadrant
LMR10520XSD/NOPB	WSON	NGG	6	1000	178.0	12.4	3.3	3.3	1.0	8.0	12.0	Q1
LMR10520XSDE/NOPB	WSON	NGG	6	250	178.0	12.4	3.3	3.3	1.0	8.0	12.0	Q1
LMR10520XSDX/NOPB	WSON	NGG	6	4500	330.0	12.4	3.3	3.3	1.0	8.0	12.0	Q1
LMR10520YSD/NOPB	WSON	NGG	6	1000	178.0	12.4	3.3	3.3	1.0	8.0	12.0	Q1
LMR10520YSDE/NOPB	WSON	NGG	6	250	178.0	12.4	3.3	3.3	1.0	8.0	12.0	Q1
LMR10520YSDX/NOPB	WSON	NGG	6	4500	330.0	12.4	3.3	3.3	1.0	8.0	12.0	Q1

TAPE AND REEL BOX DIMENSIONS



*All dimensions are nominal

Device	Package Type	Package Drawing	Pins	SPQ	Length (mm)	Width (mm)	Height (mm)
LMR10520XSD/NOPB	WSON	NGG	6	1000	208.0	191.0	35.0
LMR10520XSDE/NOPB	WSON	NGG	6	250	208.0	191.0	35.0
LMR10520XSDX/NOPB	WSON	NGG	6	4500	356.0	356.0	36.0
LMR10520YSD/NOPB	WSON	NGG	6	1000	208.0	191.0	35.0
LMR10520YSDE/NOPB	WSON	NGG	6	250	208.0	191.0	35.0
LMR10520YSDX/NOPB	WSON	NGG	6	4500	356.0	356.0	36.0

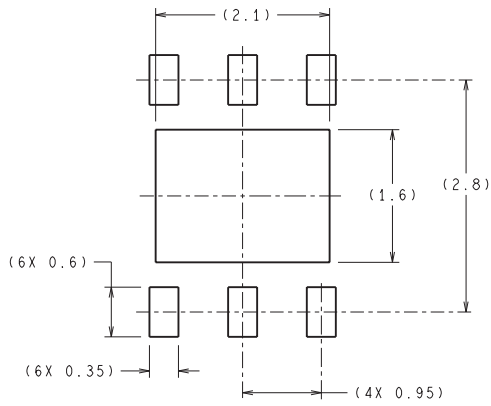
NGG0006A

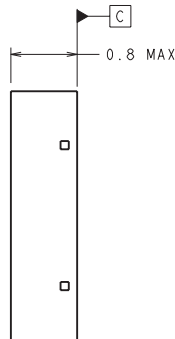
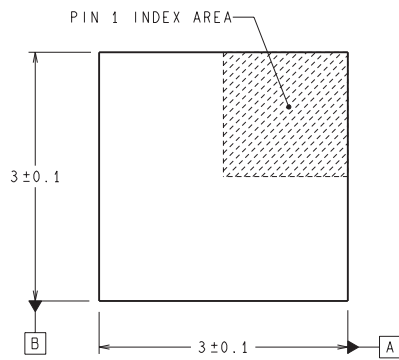

RECOMMENDED LAND PATTERN



DIMENSIONS ARE IN MILLIMETERS
DIMENSION IN () FOR REFERENCE ONLY

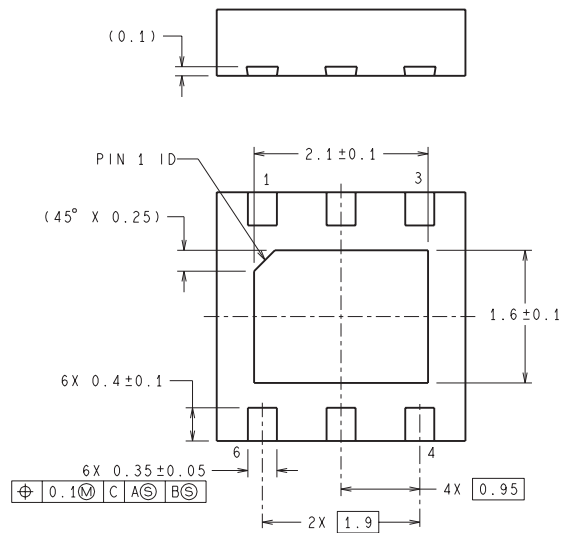

SDE06A (Rev A)

重要なお知らせと免責事項

TI は、技術データと信頼性データ(データシートを含みます)、設計リソース(リファレンス・デザインを含みます)、アプリケーションや設計に関する各種アドバイス、Web ツール、安全性情報、その他のリソースを、欠陥が存在する可能性のある「現状のまま」提供しており、商品性および特定目的に対する適合性の黙示保証、第三者の知的財産権の非侵害保証を含むいかなる保証も、明示的または黙示的にかかわらず拒否します。

これらのリソースは、TI 製品を使用する設計の経験を積んだ開発者への提供を意図したものです。(1) お客様のアプリケーションに適した TI 製品の選定、(2) お客様のアプリケーションの設計、検証、試験、(3) お客様のアプリケーションに該当する各種規格や、その他のあらゆる安全性、セキュリティ、規制、または他の要件への確実な適合に関する責任を、お客様のみが単独で負うものとし、

上記の各種リソースは、予告なく変更される可能性があります。これらのリソースは、リソースで説明されている TI 製品を使用するアプリケーションの開発の目的でのみ、TI はその使用をお客様に許諾します。これらのリソースに関して、他の目的で複製することや掲載することは禁止されています。TI や第三者の知的財産権のライセンスが付与されている訳ではありません。お客様は、これらのリソースを自身で使用した結果発生するあらゆる申し立て、損害、費用、損失、責任について、TI およびその代理人を完全に補償するものとし、TI は一切の責任を拒否します。

TI の製品は、[TI の販売条件](#)、または [ti.com](#) やかかる TI 製品の関連資料などのいずれかを通じて提供する適用可能な条項の下で提供されています。TI がこれらのリソースを提供することは、適用される TI の保証または他の保証の放棄の拡大や変更を意味するものではありません。

お客様がいかなる追加条項または代替条項を提案した場合でも、TI はそれらに異議を唱え、拒否します。

郵送先住所 : Texas Instruments, Post Office Box 655303, Dallas, Texas 75265
Copyright © 2024, Texas Instruments Incorporated