

LP5868T 8 × 18 LED 大電流マトリクスドライバ、8 ビットアナログおよび 8/16 ビット PWM 調光付き

1 特長

- LED マトリクスのトポロジ:
 - 144 の LED ドットに対する 8 のスキャン スイッチを備えた 18 個の定電流シンク
 - 1~8 に構成できるスキャン スイッチ
- 動作電圧範囲:
 - V_{CC}/V_{LED} 範囲: 2.7V~5.5V
 - 1.8V、3.3V、5V 互換のロジックピン
- 18 個の高精度定電流シンク:
 - 電流シンクあたり 100mA ($V_{CC} \geq 3.3V$)
 - デバイス間誤差: $\pm 5\%$
 - チャンネル間誤差: $\pm 5\%$
 - 位相シフトによる過渡電力の平衡化
- 極めて低い消費電力:
 - シャットダウン モード: $I_{CC} \leq 1\mu A$ (EN = Low 時)
 - スタンバイ モード: $I_{CC} \leq 10\mu A$ (EN = High かつ CHIP_EN = 0 (データ保持) 時)
 - アクティブ モード: $I_{CC} = 5mA$ (標準値)、チャンネル電流 = 12.5mA
- 柔軟な調光オプション:
 - 各 LED ドットを個別にオン / オフ制御
 - アナログ調光法 (電流ゲイン制御)
 - すべての LED ドットに対するグローバル 7 ステップ最大電流 (MC) 設定
 - 3 グループの 7 ビット カラー電流 (CC) RGB 設定
 - 各 LED ドットに対する個別の 8 ビットドット電流 (DC) 設定
 - 可聴ノイズが発生しない周波数を使った PWM 調光
 - すべての LED ドットに対するグローバル 8 ビット PWM 調光法
 - LED ドットを任意に割り当てるための 3 つのプログラム可能な 8 ビット PWM 調光法グループ
 - 各 LED ドットに対する個別の 8 ビットまたは 16 ビット PWM 調光法
- データ通信量を最小限に抑えるための完全にアドレス指定可能な SRAM
- 個別の LED ドット開放 / 短絡検出
- ゴースト除去および低輝度補償機能
- インターフェイス オプション
 - 1MHz (最大値) の I²C インターフェイス (IFS = Low 時)
 - 12MHz (最大値) の SPI インターフェイス (IFS = High 時)

2 アプリケーション

- LED アニメーションおよび表示:
 - 大型およびスマート家電
 - グローバル RGB キーボードのバックライト
 - 屋外キーパッドのバックライト
 - ビデオ監視および IP カメラ用 IR モジュール
 - 光学モジュール内のレーザー・ダイオード

3 概要

LP5868T は、大電流で高性能の LED マトリクスドライバです。本デバイスは、N (N = 6/8/11) スイッチング MOSFET を備えた 18 の定電流シンクを内蔵しており、をサポートします。LP5868T は、最大 144 の LED ドットまたは 48 の RGB LED に対応する 8 個の MOSFET を内蔵しています。

LP5868T はアナログ調光法と PWM 調光法の両方をサポートしています。アナログ調光法の場合、各 LED ドットを 256 ステップで調整できます。PWM 調光法の場合、内蔵の 8 ビットまたは 16 ビット構成可能 PWM ジェネレータが、滑らかで可聴ノイズの発生しない調光制御を実現します。各 LED ドットを 8 ビットグループ PWM に任意に割り当てることで、調光制御をまとめて行うこともできます。

LP5868T デバイスは、データ通信量を最小限に抑えるために、完全にアドレス指定可能な SRAM を実装しています。上側と下側のゴーストを除去するため、ゴーストキャンセル回路を内蔵しています。LP5868T は LED 開放 / 短絡検出機能もサポートしています。LP5868T では、1MHz (最大値) の I²C と 12MHz (最大値) の SPI が使用できます。

パッケージ情報

部品番号	パッケージ ⁽¹⁾	本体サイズ (公称)
LP5868T	RKP (VQFN, 40)	5.00mm × 5.00mm

- (1) 利用可能なすべてのパッケージについては、データシートの末尾にある注文情報を参照してください。



LP5868T

JAJSOY3B – MAY 2023 – REVISED NOVEMBER 2023

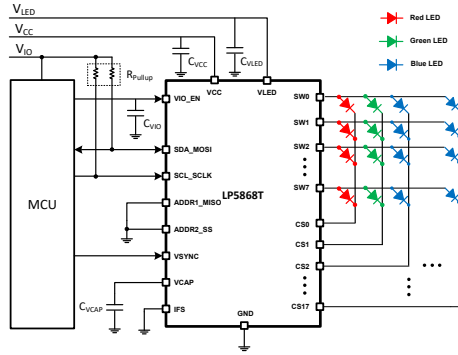

概略回路図

Table of Contents

<p>1 特長..... 1</p> <p>2 アプリケーション..... 1</p> <p>3 概要..... 1</p> <p>4 Device Comparison..... 4</p> <p>5 Pin Configuration and Functions..... 5</p> <p>6 Specifications..... 7</p> <p> 6.1 Absolute Maximum Ratings..... 7</p> <p> 6.2 ESD Ratings..... 7</p> <p> 6.3 Recommended Operating Conditions..... 7</p> <p> 6.4 Thermal Information..... 7</p> <p> 6.5 Electrical Characteristics..... 8</p> <p> 6.6 Timing Requirements..... 9</p> <p> 6.7 Typical Characteristics..... 12</p> <p>7 Detailed Description..... 14</p> <p> 7.1 Overview..... 14</p> <p> 7.2 Functional Block Diagram..... 14</p> <p> 7.3 Feature Description..... 15</p>	<p> 7.4 Device Functional Modes..... 26</p> <p> 7.5 Programming..... 27</p> <p> 7.6 Register Maps..... 32</p> <p>8 Application and Implementation..... 47</p> <p> 8.1 Application Information..... 47</p> <p> 8.2 Typical Application..... 47</p> <p> 8.3 Power Supply Recommendations..... 50</p> <p> 8.4 Layout..... 50</p> <p>9 Device and Documentation Support..... 52</p> <p> 9.1 ドキュメントの更新通知を受け取る方法..... 52</p> <p> 9.2 サポート・リソース..... 52</p> <p> 9.3 Trademarks..... 52</p> <p> 9.4 静電気放電に関する注意事項..... 52</p> <p> 9.5 用語集..... 52</p> <p>10 Revision History..... 52</p> <p>11 Mechanical, Packaging, and Orderable Information..... 53</p>
---	---

4 Device Comparison

PART NUMBER	MATERIAL	LED DOT NUMBER	MAX CURRENT PER CS	PACKAGE ⁽²⁾	SOFTWARE COMPATIBLE
LP5861T	LP5861TRSMR	18 × 1 = 18	125mA	VQFN-32	Yes
	LP5861TMRSMR ⁽¹⁾				
LP5866T	LP5866TRKPR	18 × 6 = 108	100mA	VQFN-40	
	LP5866TMRKPR ⁽¹⁾				
LP5868T	LP5868TRKPR	18 × 8 = 144			
	LP5868TMRKPR ⁽¹⁾				
LP5860T	LP5860TRKPR	18 × 11 = 198			
	LP5860TMRKPR ⁽¹⁾				
LP5861	LP5861RSMR	18 × 1 = 18	50mA	VQFN-32	
LP5862	LP5862RSMR	18 × 2 = 36		VQFN-32	
	LP5862DBTR			TSSOP-38	
LP5864	LP5864RSMR	18 × 4 = 72		VQFN-32	
	LP5864MRSMR ⁽¹⁾				
LP5866	LP5866RKPR	18 × 6 = 108		VQFN-40	
	LP5866DBTR			TSSOP-38	
	LP5866MDBTR ⁽¹⁾				
LP5868	LP5868RKPR	18 × 8 = 144		VQFN-40	
LP5860	LP5860RKPR	18 × 11 = 198		VQFN-40	
	LP5860MRKPR ⁽¹⁾				

(1) Extended Temperature devices, supporting –55°C to approximately 125°C operating ambient temperature.

(2) The same packages are hardware compatible.

5 Pin Configuration and Functions



図 5-1. LP5868T RKP Package 40-Pin VQFN with Exposed Thermal Pad Top View

表 5-1. Pin Functions

PIN		I/O	DESCRIPTION
NO.	NAME		
1	CS0	O	Current sink 0. If not used, this pin must be floating.
2	CS1	O	Current sink 1. If not used, this pin must be floating.
3	CS2	O	Current sink 2. If not used, this pin must be floating.
4	CS3	O	Current sink 3. If not used, this pin must be floating.
5	CS4	O	Current sink 4. If not used, this pin must be floating.
6	CS5	O	Current sink 5. If not used, this pin must be floating.
7	CS6	O	Current sink 6. If not used, this pin must be floating.
8	CS7	O	Current sink 7. If not used, this pin must be floating.
9	CS8	O	Current sink 8. If not used, this pin must be floating.
10	SW0	O	High-side PMOS switch output for scan line 0. If not used, this pin must be floating.
11	SW1	O	High-side PMOS switch output for scan line 1. If not used, this pin must be floating.
12	SW2	O	High-side PMOS switch output for scan line 2. If not used, this pin must be floating.
13	SW3	O	High-side PMOS switch output for scan line 3. If not used, this pin must be floating.
14	SW4	O	High-side PMOS switch output for scan line 4. If not used, this pin must be floating.
15	SW5	O	High-side PMOS switch output for scan line 5. If not used, this pin must be floating.
16	VLED	Power	Power input for high-side switches.
17	SW6	O	High-side PMOS switch output for scan line 6. If not used, this pin must be floating.
18	SW7	O	High-side PMOS switch output for scan line 7. If not used, this pin must be floating.
19	NC	-	No connection.
20	NC	-	No connection.

表 5-1. Pin Functions (続き)

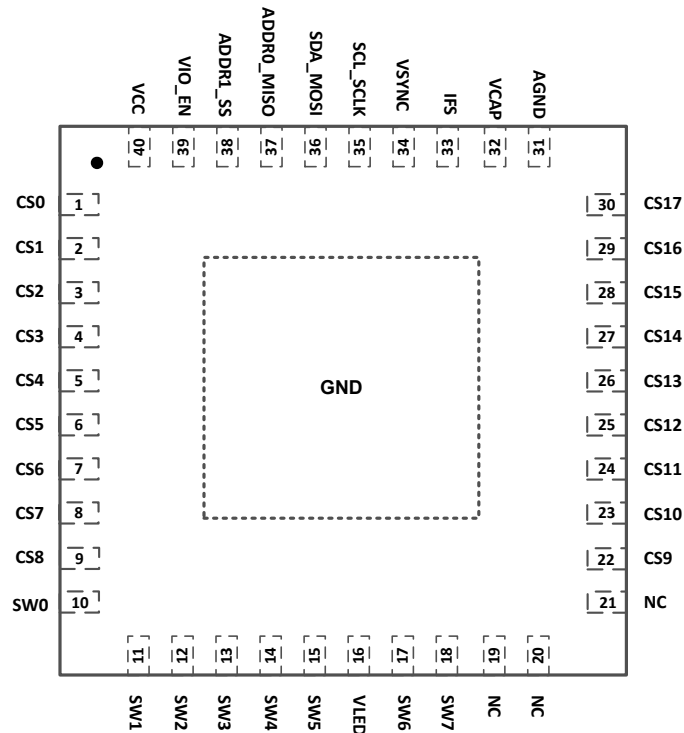
PIN		I/O	DESCRIPTION
NO.	NAME		
21	NC	-	No connection.
22	CS9	O	Current sink 9. If not used, this pin must be floating.
23	CS10	O	Current sink 10. If not used, this pin must be floating.
24	CS11	O	Current sink 11. If not used, this pin must be floating.
25	CS12	O	Current sink 12. If not used, this pin must be floating.
26	CS13	O	Current sink 13. If not used, this pin must be floating.
27	CS14	O	Current sink 14. If not used, this pin must be floating.
28	CS15	O	Current sink 15. If not used, this pin must be floating.
29	CS16	O	Current sink 16. If not used, this pin must be floating.
30	CS17	O	Current sink 17. If not used, this pin must be floating.
31	AGND	Ground	Analog ground. Must be connected to exposed thermal pad and common ground plane.
32	VCAP	O	Internal LDO output. An 1 μ F capacitor must be connected between this pin with GND. Place the capacitor as close to the device as possible.
33	IFS	I	Interface type select. I ² C is selected when IFS is low. SPI is selected when IFS is high. A resistor must be connected between VIO and this pin.
34	VSYNC	I	External synchronize signal for display mode 2 and mode 3.
35	SCL_SCLK	I	I ² C clock input or SPI clock input. Pull up to VIO when configured as I ² C.
36	SDA_MOSI	I/O	I ² C data input or SPI leader output follower input. Pull up to VIO when configured as I ² C.
37	ADDR0_MISO	I/O	I ² C address select 0 or SPI leader input follower output.
38	ADDR1_SS	I	I ² C address select 1 or SPI follower select.
39	VIO_EN	Power,I	Power supply for digital circuits and chip enable. An 1nF capacitor must be connected between this pin with GND and be placed as close to the device as possible.
40	VCC	Power	Power supply for device. A 1 μ F capacitor must be connected between this pin with GND and be placed as close to the device as possible.
Exposed Thermal Pad	GND	Ground	Must be connected to AGND and common ground plane.

6 Specifications

6.1 Absolute Maximum Ratings

over operating free-air temperature range (unless otherwise noted)⁽¹⁾

		MIN	MAX	UNIT
Voltage on V _{CC} / V _{LED} / VIO / EN / CS / SW / SDA / SCL / SCLK / MOSI / MISO / SS / ADDR0 / ADDR1 / VSYNC / IFS		-0.3	6	V
Voltage on VCAP		-0.3	2	V
T _J	Junction temperature	-55	150	°C
T _{stg}	Storage temperature	-65	150	°C

- (1) Operation outside the Absolute Maximum Ratings may cause permanent device damage. Absolute Maximum Ratings do not imply functional operation of the device at these or any other conditions beyond those listed under Recommended Operating Conditions. If used outside the Recommended Operating Conditions but within the Absolute Maximum Ratings, the device may not be fully functional, and this may affect device reliability, functionality, performance, and shorten the device lifetime.

6.2 ESD Ratings

			VALUE	UNIT
V _(ESD)	Electrostatic discharge	Human body model (HBM), per ANSI/ESDA/ JEDEC JS-001, all pins ⁽¹⁾	±3000	V
		Charged device model (CDM), per ANSI/ESDA/ JEDEC JS-002, all pins ⁽²⁾	±1000	

- (1) JEDEC document JEP155 states that 500-V HBM allows safe manufacturing with a standard ESD control process.
(2) JEDEC document JEP157 states that 250-V CDM allows safe manufacturing with a standard ESD control process.

6.3 Recommended Operating Conditions

over operating free-air temperature range (unless otherwise noted)

		MIN	NOM	MAX	UNIT
Input voltage on V _{CC}	Supply voltage	2.7		5.5	V
Input voltage on V _{LED}	LED supply voltage	2.7		5.5	V
Input voltage on VIO_EN		1.65		5.5	V
Voltage on SDA / SCL / SCLK / MOSI / MISO / SS / ADDR _x / VSYNC / IFS				VIO	V
T _A	Operating ambient temperature	-40		85	°C
T _A	Operating ambient temperature - LP5860TMRKPR, LP5866TMRKPR and LP5868TMRKPR	-55		125	°C

6.4 Thermal Information

THERMAL METRIC		LP5860T, LP5868T, LP5866T	UNIT
		RKP (VQFN)	
		40 PINS	
R _{θJA}	Junction-to-ambient thermal resistance	31.4	°C/W
R _{θJC(top)}	Junction-to-case (top) thermal resistance	22.9	°C/W
R _{θJB}	Junction-to-board thermal resistance	12.0	°C/W
Ψ _{JT}	Junction-to-top characterization parameter	0.3	°C/W
Ψ _{JB}	Junction-to-board characterization parameter	12.0	°C/W
R _{θJC(bot)}	Junction-to-case (bottom) thermal resistance	3.5	°C/W

6.5 Electrical Characteristics

$V_{CC} = 3.3V$, $V_{LED} = 5V$, $V_{IO} = 1.8V$ and $T_A = -40^{\circ}C$ to $+85^{\circ}C$ ($T_A = -55^{\circ}C$ to $+125^{\circ}C$ for LP5860TMRKPR, LP5866TMRKPR and LP5868TMRKPR); Typical values are at $T_A = 25^{\circ}C$ (unless otherwise specified)

PARAMETER		TEST CONDITIONS	MIN	TYP	MAX	UNIT
Power supplies						
V_{CC}	Device supply voltage		2.7		5.5	V
V_{UVR}	Undervoltage restart	V_{CC} rising, Test mode			2.5	V
V_{UVF}	Undervoltage shutdown	V_{CC} falling, Test mode	1.9			V
V_{UV_HYS}	Undervoltage shutdown hysteresis			0.3		V
V_{CAP}	Internal LDO output	$V_{CC} = 2.7V$ to $5.5V$		1.78		V
I_{CC}	Shutdown supply current $I_{SHUTDOWN}$	$V_{EN} = 0$, $CHIP_EN = 0$ (bit), $ADDx = 0$; measure the total current from V_{CC} and V_{LED}		0.1	1.5	μA
	Standby supply current $I_{STANDBY}$	$V_{EN} = 3.3V$, $CHIP_EN = 0$ (bit), measure the total current from V_{CC} and V_{LED}		5.5	12	μA
	Active mode supply current I_{NORMAL}	$V_{EN} = 3.3V$, $CHIP_EN = 1$ (bit), all channels $I_{OUT} = 12.5$ mA ($MC = 1$, $CC = 127$, $DC = 256$), measure the current from V_{CC}		4.3	6	mA
V_{LED}	LED supply voltage		2.7		5.5	V
V_{VIO}	VIO supply voltage		1.65		5.5	V
I_{VIO}	VIO supply current	Interface idle			5	μA
Output Stages						
I_{CS}	Constant current sink output range (CS0 – CS17)	$2.7 \leq V_{CC} < 3.3V$, PWM = 100%	0.1		75	mA
		$V_{CC} \geq 3.3V$ PWM = 100%	0.1		100	mA
I_{LKG}	Leakage current (CS0 – CS17)	channels off, up_degghost = 0, $V_{CS} = 5V$		0.1	1	μA
I_{ERR_DD}	Device to device current error, $I_{ERR_DD} = (I_{AVE} - I_{SET}) / I_{SET} \times 100\%$	All channels ON. Current set to 1 mA. $MC = 0$ $CC = 17$ $DC = 255$ $PWM = 100\%$	-5		5	%
		All channels ON. Current set to 25 mA. $MC = 2$ $CC = 127$ $DC = 255$ $PWM = 100\%$	-5		5	%
		All channels ON. Current set to 50 mA. $MC = 4$ $CC = 127$ $DC = 255$ $PWM = 100\%$	-5		5	%
		All channels ON. Current set to 75 mA. $MC = 5$ $CC = 64$ $DC = 255$ $PWM = 100\%$	-5		5	%
		All channels ON. Current set to 100 mA. $MC = 6$ $CC = 127$ $DC = 255$ $PWM = 100\%$	-5		5	%
I_{ERR_CC}	Channel to channel current error, $I_{ERR_CC} = (I_{OUTx} - I_{AVE}) / I_{AVE} \times 100\%$	All channels ON. Current set to 1 mA. $MC = 0$ $CC = 17$ $DC = 255$ $PWM = 100\%$	-5		5	%
		All channels ON. Current set to 25 mA. $MC = 2$ $CC = 127$ $DC = 255$ $PWM = 100\%$	-5		5	%
		All channels ON. Current set to 50 mA. $MC = 4$ $CC = 127$ $DC = 255$ $PWM = 100\%$	-5		5	%
		All channels ON. Current set to 75 mA. $MC = 5$ $CC = 64$ $DC = 255$ $PWM = 100\%$	-5		5	%
		All channels ON. Current set to 100 mA. $MC = 6$ $CC = 127$ $DC = 255$ $PWM = 100\%$	-5		5	%
f_{PWM}	LED PWM frequency	PWM_Fre = 1, PWM = 100%		62.5		KHz
		PWM_Fre = 0, PWM = 100%		125		KHz

$V_{CC} = 3.3V$, $V_{LED} = 5V$, $V_{IO} = 1.8V$ and $T_A = -40^{\circ}C$ to $+85^{\circ}C$ ($T_A = -55^{\circ}C$ to $+125^{\circ}C$ for LP5860TMRKPR, LP5866TMRKPR and LP5868TMRKPR); Typical values are at $T_A = 25^{\circ}C$ (unless otherwise specified)

PARAMETER		TEST CONDITIONS	MIN	TYP	MAX	UNIT
V_{SAT}	Output saturation voltage	$I_{OUT} = 100mA$, decreasing output voltage, when the LED current has dropped 5% (only apply to LP5860TMRKPR, LP5866TMRKPR and LP5868TMRKPR)			0.8	V
		$I_{OUT} = 100mA$, decreasing output voltage, when the LED current has dropped 5% (only apply to LP5860TRKPR, LP5866TRKPR and LP5868TRKPR)			0.7	V
		$I_{OUT} = 75mA$, decreasing output voltage, when the LED current has dropped 5%			0.6	V
		$I_{OUT} = 25mA$, decreasing output voltage, when the LED current has dropped 5%			0.5	V
R_{SW}	High-side PMOS ON resistance	$V_{LED} = 2.7V$, $I_{SW} = 200mA$		450		m Ω
		$V_{LED} = 2.7V$, $I_{SW} = 200mA$, LP5860MRKPR and LP5864MRSMR		450		m Ω
		$V_{LED} = 3.8V$, $I_{SW} = 200mA$		380		m Ω
		$V_{LED} = 3.8V$, $I_{SW} = 200mA$, LP5860MRKPR and LP5864MRSMR		380		m Ω
		$V_{LED} = 5V$, $I_{SW} = 200mA$		310		m Ω
		$V_{LED} = 5V$, $I_{SW} = 200mA$, LP5860MRKPR and LP5864MRSMR		310		m Ω
Logic Interfaces						
V_{LOGIC_IL}	Low-level input voltage, SDA, SCL, SCLK, MOSI, SS, ADDR _x , VSYNC, IFS			0.3 x V_{IO}		V
V_{LOGIC_IH}	High-level input voltage, SDA, SCL, SCLK, MOSI, SS, ADDR _x , VSYNC, IFS		0.7 x V_{IO}			V
V_{EN_IL}	Low-level input voltage of EN			0.4		V
V_{EN_IH}	High-level input voltage of EN	When V_{CAP} powered up	1.4			V
I_{LOGIC_I}	Input current, SDA, SCL, SCLK, MOSI, SS, ADDR _x		-1		1	μA
V_{LOGIC_OL}	Low-level output voltage, SDA, MISO	$I_{PULLUP} = 3mA$			0.4	V
V_{LOGIC_OH}	High-level output voltage, MISO	$I_{PULLUP} = -3mA$	0.7 x V_{IO}			V
Protection Circuits						
V_{LOD_TH}	Threshold for channel open detection			0.25		V
V_{LSD_TH}	Threshold for channel short detection			$V_{LED} - 1$		V
T_{TSD}	Thermal-shutdown junction temperature			150		$^{\circ}C$
T_{HYS}	Thermal shutdown temperature hysteresis			15		$^{\circ}C$

6.6 Timing Requirements

		MIN	NOM	MAX	UNIT
MISC. Timing Requirements					
f_{OSC}	Internal oscillator frequency		31.2		MHz
f_{OSC_ERR}	Device to device oscillator frequency error	-3%		3%	
t_{POR_H}	Wait time from UVLO disactive to device NORMAL			500	μs
t_{CHIP_EN}	Wait time from setting Chip_EN (Register) =1 to device NORMAL			100	μs
t_{RISE}	LED output rise time		10		ns

		MIN	NOM	MAX	UNIT
t_{FALL}	LED output fall time		15		ns
$t_{\text{VSYNC_H}}$	The minimum high-level pulse width of VSYNC	200			μs
SPI timing requirements					
f_{SCLK}	SPI Clock frequency			12	MHz
1	Cycle time	83.3			ns
2	SS active lead-time	50			ns
3	SS active leg time	50			ns
4	SS inactive time	50			ns
5	SCLK low time	36			ns
6	SCLK high time	36			ns
7	MOSI set-up time	20			ns
8	MOSI hold time	20			ns
9	MISO disable time			30	ns
10	MISO data valid time			35	ns
C_b	Bus capacitance	5		40	pF
I²C fast mode timing requirements					
f_{SCL}	I ² C clock frequency	0		400	KHz
1	Hold time (repeated) START condition	600			ns
2	Clock low time	1300			ns
3	Clock high time	600			ns
4	Setup time for a repeated START condition	600			ns
5	Data hold time	0			ns
6	Data setup time	100			ns
7	Rise time of SDA and SCL			300	ns
8	Fall time of SDA and SCL			300	ns
9	Setup time for STOP condition	600			ns
10	Bus free time between a STOP and a START condition	1.3			μs
I²C fast mode plus timing requirements					
f_{SCL}	I ² C clock frequency	0		1000	KHz
1	Hold time (repeated) START condition	260			ns
2	Clock low time	500			ns
3	Clock high time	260			ns
4	Setup time for a repeated START condition	260			ns
5	Data hold time	0			ns
6	Data setup time	50			ns
7	Rise time of SDA and SCL			120	ns
8	Fall time of SDA and SCL			120	ns
9	Setup time for STOP condition	260			ns
10	Bus free time between a STOP and a START condition	0.5			μs



图 6-1. SPI Timing Parameters



图 6-2. I²C Timing Parameters

6.7 Typical Characteristics

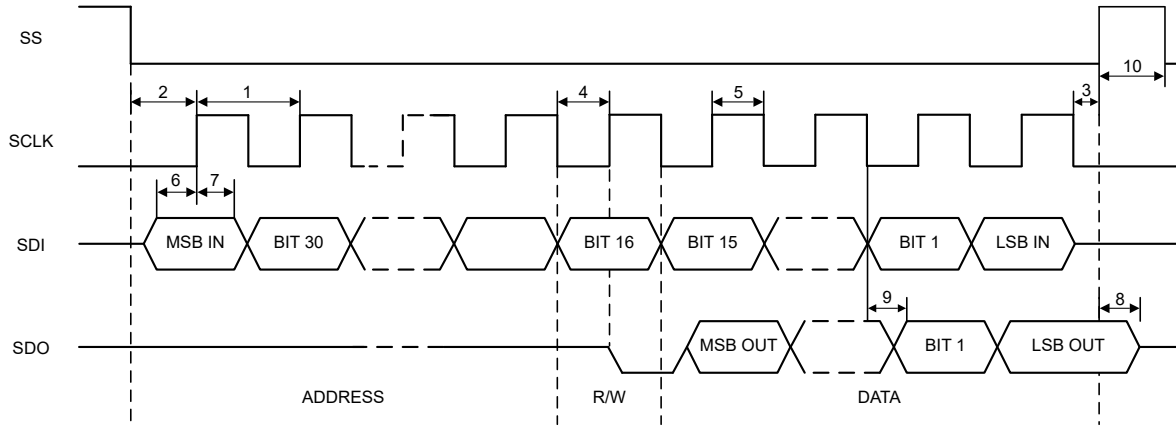
Unless specified otherwise, typical characteristics apply over the full ambient temperature range ($-55^{\circ}\text{C} < T_A < +125^{\circ}\text{C}$ for LP5868TMRKPR, LP5864MRSMR, and LP5866MDBTR while $-40^{\circ}\text{C} < T_A < +85^{\circ}\text{C}$ for the other devices), $V_{CC} = 3.3\text{V}$, $V_{IO} = 3.3\text{V}$, $V_{LED} = 5\text{V}$, $I_{LED_Peak} = 50\text{mA}$, $C_{VLED} = 1\mu\text{F}$, $C_{VCC} = 1\mu\text{F}$.

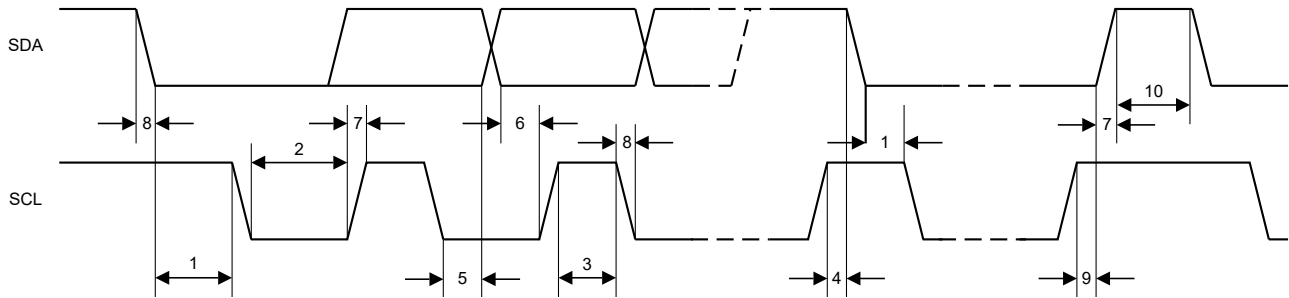
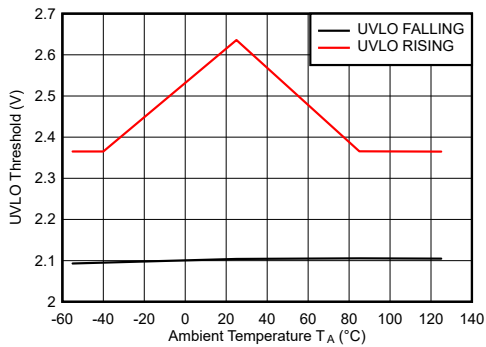

6-3. V_{CC} UVLO Rising and Falling Thresholds

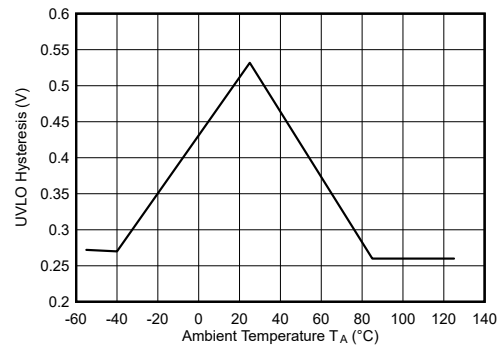

6-4. V_{CC} UVLO Hysteresis

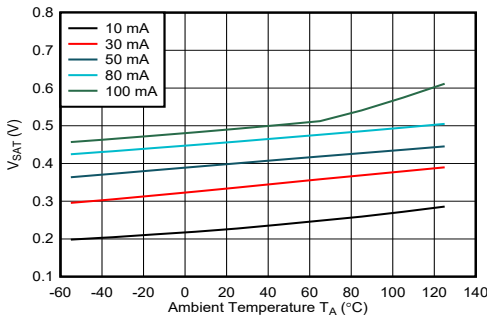

6-5. V_{SAT} vs Temperature

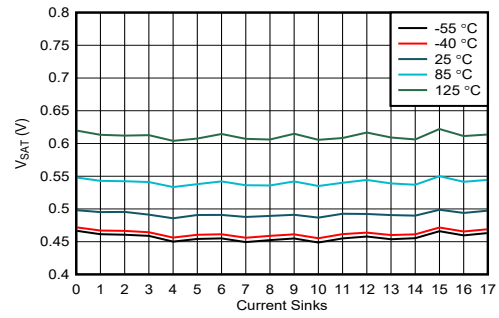

6-6. V_{SAT} vs Current Sinks (100mA)

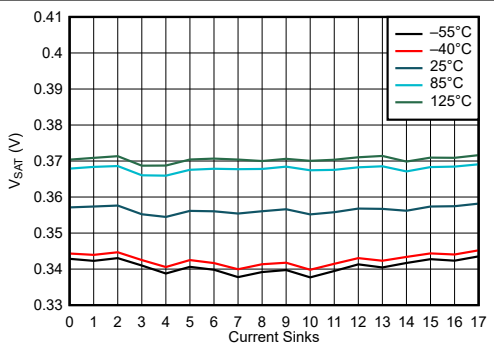

6-7. V_{SAT} vs Current Sinks (50mA)

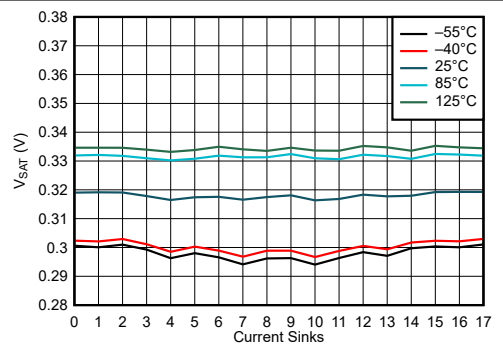

6-8. V_{SAT} vs Current Sinks (30mA)

6.7 Typical Characteristics (continued)

Unless specified otherwise, typical characteristics apply over the full ambient temperature range ($-55^{\circ}\text{C} < T_A < +125^{\circ}\text{C}$ for LP5868TMRKPR, LP5864MRSMR, and LP5866MDBTR while $-40^{\circ}\text{C} < T_A < +85^{\circ}\text{C}$ for the other devices), $V_{CC} = 3.3\text{V}$, $V_{IO} = 3.3\text{V}$, $V_{LED} = 5\text{V}$, $I_{LED_Peak} = 50\text{mA}$, $C_{VLED} = 1\mu\text{F}$, $C_{VCC} = 1\mu\text{F}$.

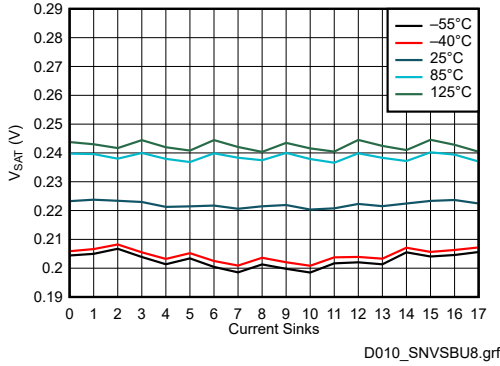

6-9. V_{SAT} vs Current Sinks (10mA)

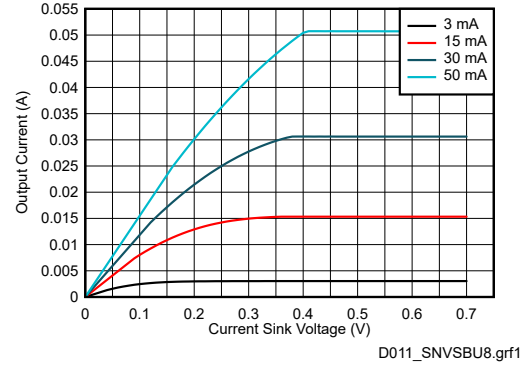

$T_A = 25^{\circ}\text{C}$

6-10. Current Sinks Voltage vs Current

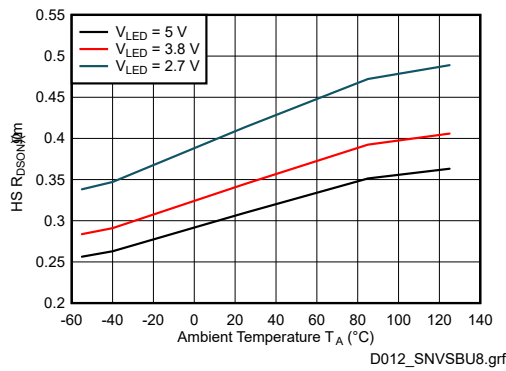

6-11. High Side Switch $R_{DS(on)}$

7 Detailed Description

7.1 Overview

The LP5868T is an 8 × 18 LED matrix driver. The device integrates 8 switching FETs with 18 constant current sinks. One LP5868T device can drive up to 144 LED dots or 48 RGB pixels by using time-multiplexing matrix scheme.

The LP5868T supports both analog dimming and PWM dimming methods. For analog dimming, the current gain of each individual LED dot can be adjusted with 256 steps through 8-bits dot correction. For PWM dimming, the integrated 8-bits or 16-bits configurable, > 20KHz PWM generators for each LED dot enable smooth, vivid animation effects without audible noise. Each LED can also be mapped into a 8-bits group PWM to achieve the group control with minimum data traffic.

The LP5868T device implements full addressable SRAM. The device supports entire SRAM data refresh and partial SRAM data update on demand to minimize the data traffic. The LP5868T implements the ghost cancellation circuit to eliminate both upside and downside ghosting. The LP5868T also uses low brightness compensation technology to support high density LED pixels. Both 1MHz (maximum) I²C and 12MHz (maximum) SPI interfaces are available in the LP5868T.

7.2 Functional Block Diagram

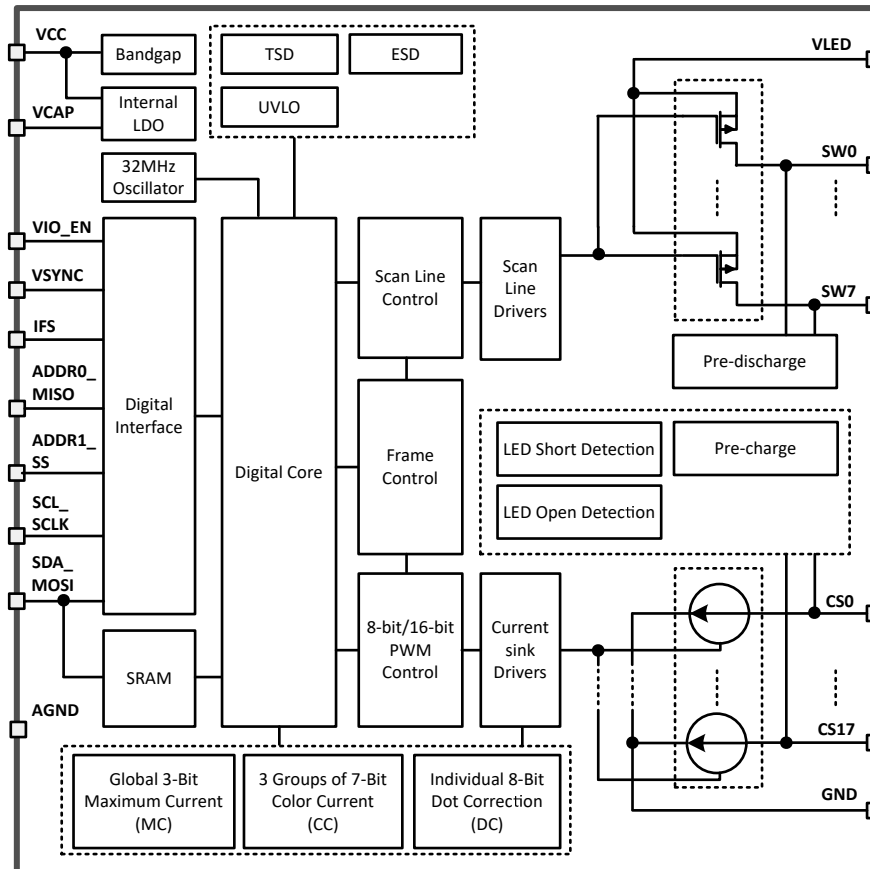

7.3 Feature Description

7.3.1 Time-Multiplexing Matrix

The LP5868T device uses a time-multiplexing matrix scheme to support up to 144 LED dots with one chip. The device integrates 18 current sinks with 8 scan lines to drive $18 \times 8 = 144$ LED dots or $6 \times 8 = 48$ RGB pixels. In matrix control scheme, the device scans from Line 0 to Line 7 sequentially as shown in [Figure 7-1](#). Current gain and PWM duty registers are programmable for each LED dot to support individual analog and PWM dimming.

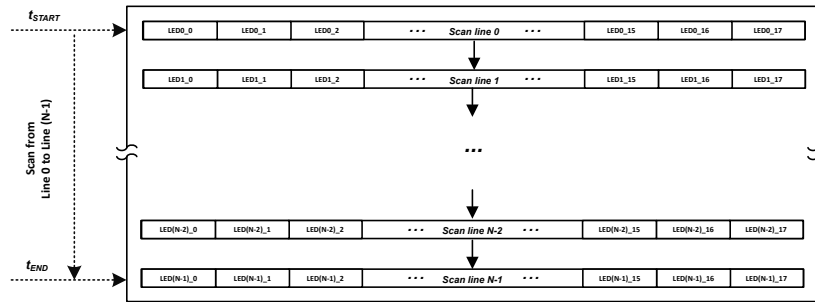

Figure 7-1. Scan Line Control Scheme

There are 8 high-side p-channel MOSFETs (PMOS) integrated in LP5868T device. Users can flexibly set the active scan numbers from 6 to 8 by configuring the 'Max_Line_Num' in Dev_initial register. The time-multiplexing matrix timing sequence follows the [Figure 7-2](#).

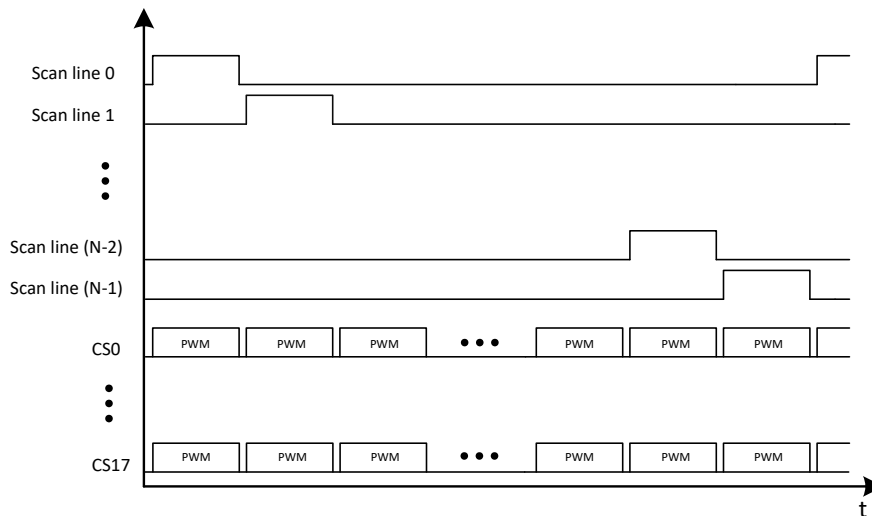

Figure 7-2. Time-Multiplexing Matrix Timing Sequence

One cycle time of the line switching can be calculated as below:

$$t_{\text{line_switch}} = t_{\text{PWM}} + t_{\text{SW_BLK}} + 2 \times t_{\text{phase_shift}} \quad (1)$$

- t_{PWM} is the current sink active time, which equals to $8\mu\text{s}$ (PWM frequency set at 125kHz) or $16\mu\text{s}$ (PWM frequency set at 62.5kHz) by configuring 'PWM_Fre' in Dev_initial register.
- $t_{\text{SW_BLK}}$ is the switch blank time, which equals to $1\mu\text{s}$ or $0.5\mu\text{s}$ by configuring 'SW_BLK' in Dev_config1 register.
- $t_{\text{phase_shift}}$ is the PWM phase shift time, which equal to 0 or 125ns by configuring 'PWM_Phase_Shift' in Dev_config1 register.

Total display time for one complete sub-period is $t_{\text{sub_period}}$ and can be calculated by the following equation:

$$t_{\text{sub_period}} = t_{\text{line_switch}} \times \text{Scan_line\#} \quad (2)$$

- Scan_line# is the scan line number determined by 'Max_Line_Num' in Dev_initial register.

The time-multiplexing matrix scheme time diagram is shown in [Figure 7-3](#). The $t_{\text{CS_ON_Shift}}$ is the current sink turning on shift by configuring 'CS_ON_Shift' bit in Dev_config1 register.

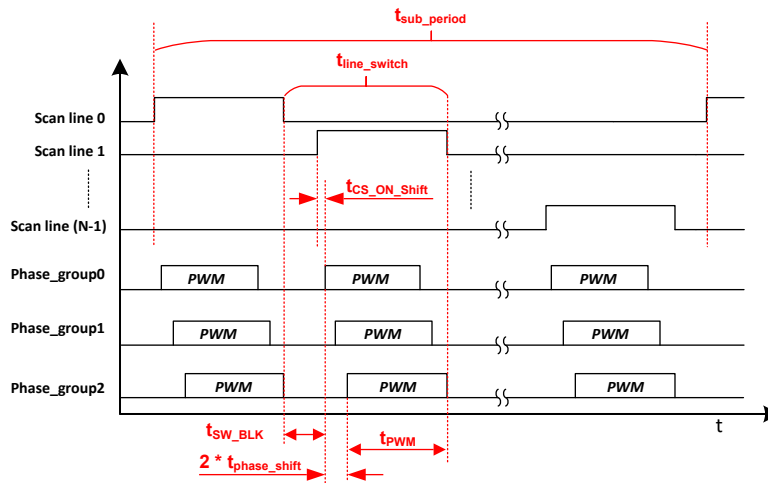

Figure 7-3. Time-Multiplexing Matrix Timing Diagram

The LP5868T device implements de-ghosting and low brightness compensation to remove the side effects of matrix topology:

- **De-ghosting:** Both upside de-ghosting and downside de-ghosting are implemented to eliminate the LED's unexpected weak turn-on.
 - Upside_de-ghosting: discharge each scan line during blank state. By configuring the 'Up_Deghost' in Dev_config3 register, the LP5868T discharges and clamps the scan line switch to a certain voltage.
 - Downside_deghosting: pre-charge each current sink voltage during blank state. The de-ghosting capability can be adjusted through the 'Down_Deghost' in Dev_config3 register.
- **Low Brightness Compensation:** three groups compensation are implemented to overcome the color-shift and non-uniformity in low brightness conditions. The compensation capability can be through 'Comp_Group1', 'Comp_Group2', and 'Comp_Group3' in Dev_config2 register.
 - Compensation_group 1: CS0, CS3, CS6, CS9, CS12, CS15.
 - Compensation_group 2: CS1, CS4, CS7, CS10, CS13, CS16.
 - Compensation_group 3: CS2, CS5, CS8, CS11, CS14, CS17.

7.3.2 Analog Dimming (Current Gain Control)

Analog dimming of LP5868T is achieved by configuring the current gain control. There are several methods to control the current gain of each LED.

- Global 3-bits Maximum Current (MC) setting without external resistor
- 3 Groups of 7-bits Color Current (CC) setting
- Individual 8-bit Dot Current (DC) setting

注

When setting to small output current in low brightness situation, adjusting MC to a small value firstly can get smaller output saturation voltage.

7.3.2.1 Global 3-Bits Maximum Current (MC) Setting

The MC is used to set the maximum current I_{OUT_MAX} for each current sink, and this current is the maximum peak current for each LED dot. The MC can be set with 7 steps from 7.5 mA to 100 mA. When the device is powered on, the MC data is set to default value, which is 37.5 mA.

For data refresh [Mode 1](#), MC data is effective immediately after new data is updated. For [Mode 2](#) and [Mode 3](#), to avoid unexpected MC data change during high speed data refreshing, MC data must be changed when all channels are off and new MC data is only updated when the 'Chip_EN' bit in Chip_en register is set to 0, and after the 'Chip_EN' returns to 1, the new MC data is effective. 'Down_Deghost' and 'Up_Deghost' in Dev_config3 work in the similar way with MC.

表 7-1. Maximum Current (MC) Register Setting

3-BITS MAXIMUM_CURRENT REGISTER		I_{OUT_MAX}
Binary	Decimal	mA
000	0	7.5
001	1	12.5
010	2	25
011 (Default)	3 (Default)	37.5 (Default)
100	4	50
101	5	75
110	6	100

7.3.2.2 3 Groups of 7-Bits Color Current (CC) Setting

The LP5868T device is able to adjust the output current of three color groups separately. For each color, the device has 7-bits data in 'CC_Group1', 'CC_Group2', and 'CC_Group3'. Thus, all color group currents can be adjusted in 128 steps from 0% to 100% of the maximum output current, I_{OUT_MAX} .

The 18 current sinks have fixed mapping to the three color groups:

- CC-Group 1: CS0, CS3, CS6, CS9, CS12, CS15.
- CC-Group 2: CS1, CS4, CS7, CS10, CS13, CS16.
- CC-Group 3: CS2, CS5, CS8, CS11, CS14, CS17.

表 7-2. 3 Groups of 7-bits Color Current (CC) Setting

7-BITS CC_GROUP1/CC_GROUP2/CC_GROUP3 REGISTER		RATIO OF OUTPUT CURRENT TO I_{OUT_MAX}
Binary	Decimal	%
000 0000	0	0
000 0001	1	0.79
000 0010	2	1.57
---	---	---
100 0000 (default)	64 (default)	50.4 (default)
---	---	---
111 1101	125	98.4
111 1110	126	99.2
111 1111	127	100

7.3.2.3 Individual 8-bit Dot Current (DC) Setting

The LP5868T can individually adjust the output current of each LED by using dot current function through DC setting. The device allows the brightness deviations of the LEDs to adjusted be individually. Each output DC is programmed with an 8-bit depth, so the value can be adjusted with 256 steps within the range from 0% to 100% of ($I_{OUT_MAX} \times CC/127$).

表 7-3. Individual 8-bit Dot Current (DC) Setting

8-BIT DC REGISTER		RATIO OF OUTPUT CURRENT TO $I_{OUT_MAX} \times CC/127$
Binary	Decimal	%
0000 0000	0	0
0000 0001	1	0.39
0000 0010	2	0.78
---	---	---
1000 0000 (Default)	128 (Default)	50.2 (Default)
---	---	---
1111 1101	253	99.2
1111 1110	254	99.6
1111 1111	255	100

In summary, the current gain of each current sink can be calculated as below:

$$I_{OUT} \text{ (mA)} = I_{OUT_MAX} \times (CC/127) \times (DC/255) \tag{3}$$

For time-multiplexing scan scheme, if the scan number is N, each LED dot's average current I_{AVG} is shown as below:

$$I_{AVG} \text{ (mA)} = I_{OUT}/N = I_{OUT_MAX} \times (CC/127) \times (DC/255)/N \tag{4}$$

7.3.3 PWM Dimming

There are several methods to control the PWM duty cycle of each LED dot.

7.3.3.1 Individual 8-Bit / 16-Bit PWM for Each LED Dot

Every LED has an individual 8-bit or 16-bit PWM register that is used to change the LED brightness by PWM duty. The LP5868T uses an enhanced spectrum PWM (ES-PWM) algorithm to achieve 16-bit depth with high refresh rate and this can avoid flicker under high speed camera. Comparing with conventional 8-bit PWM, 16-bit PWM can help to achieve ultimate high dimming resolution in LED animation applications.

7.3.3.2 Programmable Groups of 8-Bit PWM Dimming

The group PWM Control is used to select LEDs into 1 to 3 groups while each group has a separate register for PWM control. Every LED has 2-bit selection in LED_DOT_GROUP Registers ($x = 0, 1, \dots, 39$) to select whether the LED dot belongs to one of the three groups or not:

- 00: not a member of any group
- 01: member of group 1
- 10: member of group 2
- 11: member of group 3

7.3.3.3 8-Bit PWM for Global Dimming

The Global PWM Control function affects all LEDs simultaneously.

The final PWM duty cycle can be calculated as below:

$$\text{PWM_Final(8-bit)} = \text{PWM_Individual(8-bit)} \times \text{PWM_Group(8-bit)} \times \text{PWM_Global(8-bit)} \quad (5)$$

$$\text{PWM_Final(16-bit)} = \text{PWM_Individual(16-bit)} \times \text{PWM_Group(8-bit)} \times \text{PWM_Global(8-bit)} \quad (6)$$

The LP5868T supports 125kHz or 62.5kHz PWM output frequency. The PWM frequency is selected by configuring the 'PWM_Fre' in Dev_initial register. An internal 31.2MHz oscillator is used for generating PWM outputs. The oscillator's high accuracy design ($f_{\text{OSC_ERR}} \leq \pm 3\%$) enables a better synchronization if multiple LP5868T devices are connected together.

A PWM phase-shifting scheme is implemented in each current sink to avoid the current overshoot when turning on simultaneously. As the LED drivers are not activated simultaneously, the peak load current from the pre-stage power supply is significantly decreased. This scheme also reduces input-current ripple and ceramic-capacitor audible ringing. LED drivers are grouped into three different phases. By configuring the 'PWM_Phase_Shift' in Dev_config1 register, which is default off, the LP5868T supports $t_{\text{phase_shift}} = 125\text{ns}$ shifting time shown in [Figure 7-4](#).

- Phase 1: CS0, CS3, CS6, CS9, CS12, CS15.
- Phase 2: CS1, CS4, CS7, CS10, CS13, CS16.
- Phase 3: CS2, CS5, CS8, CS11, CS14, CS17.

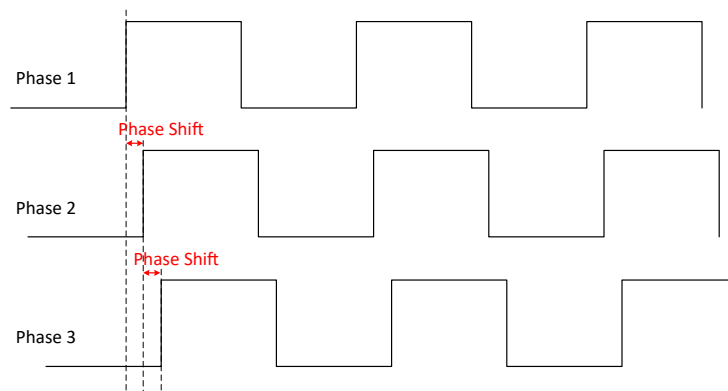
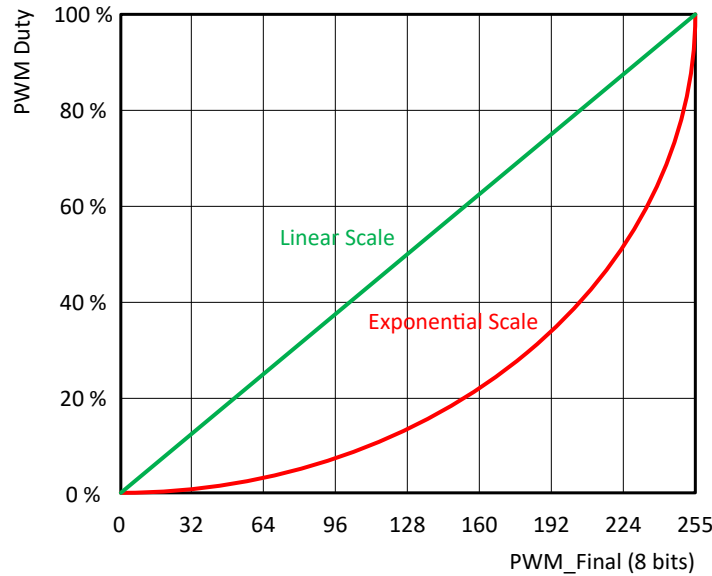

Figure 7-4. Phase Shift

To avoid high current sinks output ripple during line switching, current sinks can be configured to turn on with 1 clock delay (62.5ns or 31.25ns according to the PWM frequency) after lines turn on, as shown in 7-3. This function can be configured by 'CS_ON_Shift' in Dev_config1 register.

The LP5868T allows users to configure the dimming scale either exponentially (Gamma Correction) or linearly through the 'PWM_Scale_Mode' in Dev_config1 register. If a human-eye-friendly dimming curve is desired, using the internal fixed exponential scale is an easy approach. If a special dimming curve is desired, using the linear scale with software correction is recommended. The LP5868T supports both linear and exponential dimming curves under 8-bit and 16-bit PWM depth. 7-5 is an example of 8-bit PWM depth.



7-5. Linear and Exponential Dimming Curves

In summary, the PWM control method is illustrated as 7-6:

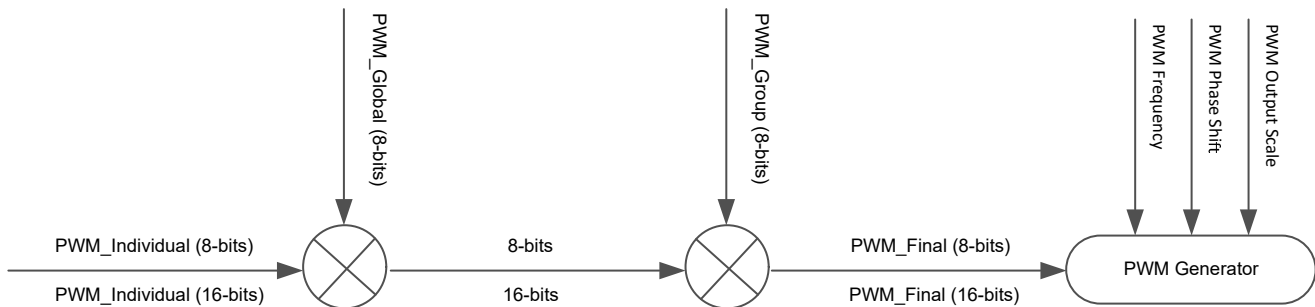

7-6. PWM Control Scheme

7.3.4 ON and OFF Control

The LP5868T device supports the individual ON and OFF control of each LED. For indication purpose, users can turn on and off the LED directly by writing 1-bit ON and OFF data to the corresponding Dot_onoffx (x = 0, 1, ... , 23) register.

7.3.5 Data Refresh Mode

The LP5868T supports three data refresh modes: Mode 1, Mode 2, and Mode 3, by configuring 'Data_Ref_Mode' in Dev_initial register.

Mode 1: 8-bit PWM data without VSYNC command. Data is sent out for display instantly after received. With Mode1, users can refresh the corresponding dots' data only instead of updating the whole SRAM. It is called 'on demand data refresh', which can save the total data volume effectively. As shown in [Figure 7-7](#), the red LED dots can be refreshed after sending the corresponding data while the others kept the same with last frame.

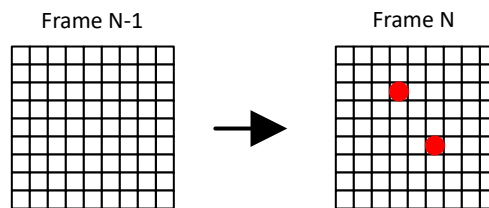

Figure 7-7. On Demand Data Refresh - Mode 1

Mode 2: 8-bit PWM data with VSYNC command. Data is held and sent out simultaneously by frame after receiving the VSYNC command.

Mode 3: 16-bit PWM data with VSYNC command. Data is held and sent out simultaneously by frame after receiving the VSYNC command.

Frame control is implemented in Mode 2 and Mode 3. Instead of refreshing the output instantly after data is received (Mode 1), the device holds the data and refreshes the whole frame data by a fixed frame rate, f_{VSYNC} . Usually, 24Hz, 50Hz, 60Hz, 120Hz or even higher frame rate is selected to achieve vivid animation effects. Whole SRAM Data Refresh is shown in [Figure 7-8](#), a new frame is updated after receiving the VSYNC command.

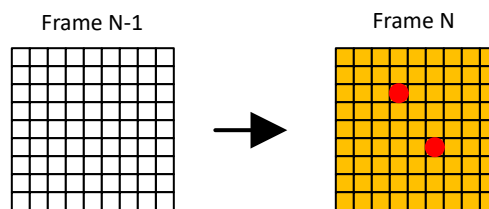

Figure 7-8. Whole SRAM Data Refresh

Comparing with Mode 1, Mode 2 and Mode 3 provide a better synchronization when multiple LP5868T devices used together. A high-level pulse width longer than $t_{\text{SYNC_H}}$ is required at the beginning of each VSYNC frame. [Figure 7-9](#) shows the VSYNC connections and [Figure 7-10](#) shows the timing requirements.

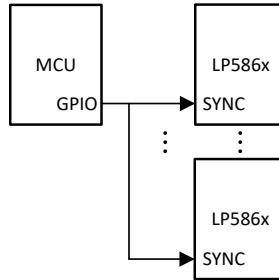

Figure 7-9. Multiple Devices Sync

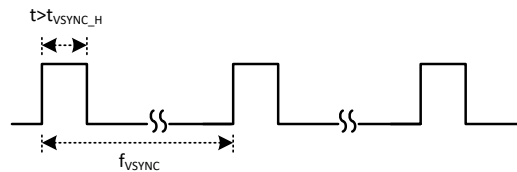

Figure 7-10. VSYNC Timing

Table 8-4 is the summary of the 3 data refresh modes.

Table 7-4. Data Refresh Mode

MODE TYPE	PWM RESOLUTION	PWM OUTPUT	EXTERNAL VSYNC
Mode 1	8 Bits	Data update instantly	No
Mode 2	8 Bits	Data update by frame	Yes
Mode 3	16 Bits		

7.3.6 Full Addressable SRAM

SRAM is implemented inside the LP5868T device to support data writing and reading at the same time.

Although data refresh mechanisms are not the same for Mode 1 and Mode 2/3, the data writing and reading follow the same method. Users can update partial of the SRAM data only or the whole SRAM page simultaneously. The LP5868T supports auto-increment function to minimize data traffic and increase data transfer efficiency.

Please be noted that 16-bit PWM (Mode 3) and 8-bit PWM (Mode 1 and Mode 2) are assigned with different SRAM addresses.

7.3.7 Protections and Diagnostics

7.3.7.1 LED Open Detection

The LP5868T includes LED open detection (LOD) for the fault caused by any opened LED dot. The threshold for LED open is 0.25V typical. LED open detection is only performed when PWM \geq 25 (Mode 1 and Mode 2) or PWM \geq 6400 (Mode 3) and voltage on CSn is detected lower than open threshold for continuously 4 sub-periods.

Figure 7-11 shows the detection circuit of LOD function. When open fault is detected, 'Global_LOD' bit in Fault_state register is set to 1 and detailed fault state for each LED is also monitored in register Dot_lodx (x = 0, 1, ..., 23). All open fault indicator bits can be cleared by setting LOD_clear = 0Fh after the open condition is removed.

LOD removal function can be enabled by setting 'LOD_removal' bit in Dev_config2 register to 1. This function turns off the current sink of the open channel when scanning to the line where the opened LED is included.



图 7-11. LOD Circuits

7.3.7.2 LED Short Detection

The LP5868T includes LED short detection (LSD) for the fault caused by any shorted LED. Threshold for channel short is $(V_{LED} - 1)$ V typical. LED short detection only performed when $PWM \geq 25$ (Mode 1 and Mode 2) or $PWM \geq 6400$ (Mode 3) and voltage on CS_n is detected higher than short threshold for continuously 4 sub-periods. As there is parasitic capacitance for the current sink, to make sure the LSD result is correct, setting the LED current higher than 0.5mA is recommended.

The image below shows the detection circuit of LSD function. When short fault is detected, 'Global_LSD bit' in Fault_state register is set to 1 and detailed fault state for every channel are also monitored in register Dot_Isdx ($x = 0, 1, \dots, 23$). All short fault indicator bits can be cleared by setting $LSD_clear = 0Fh$ after the short condition is removed.

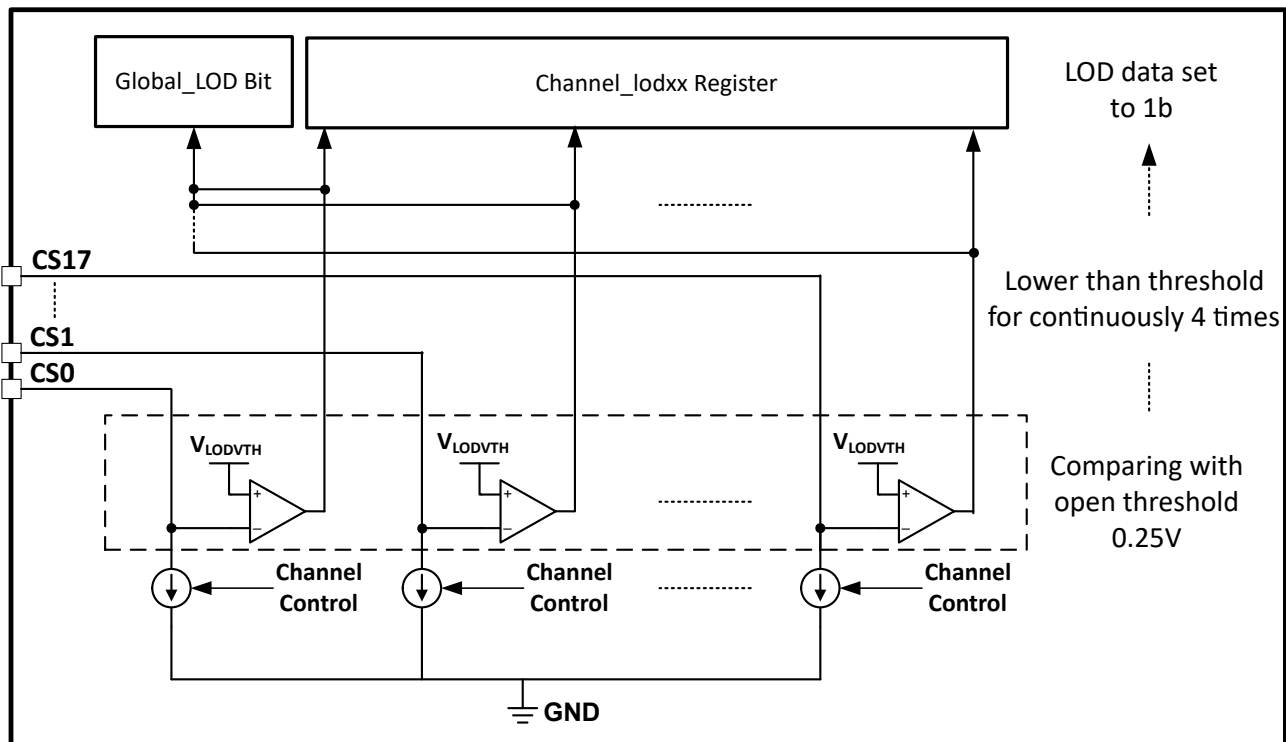
LSD removal function can be enabled by setting 'LSD_removal' bit in Dev_config2 register to 1. This function turns off the upside deghosting function of the scan line where short LED is included.



図 7-12. LSD Circuit

7.3.7.3 Thermal Shutdown

The LP5868T device implements thermal shutdown mechanism to protect the device from damage due to overheating. When the junction temperature rises to 160°C (typical) and above, the device switches into shutdown mode. The LP5868T exits thermal shutdown when the junction temperature of the device drops to 145°C (typical) and below.

7.3.7.4 UVLO (Under Voltage Lock Out)

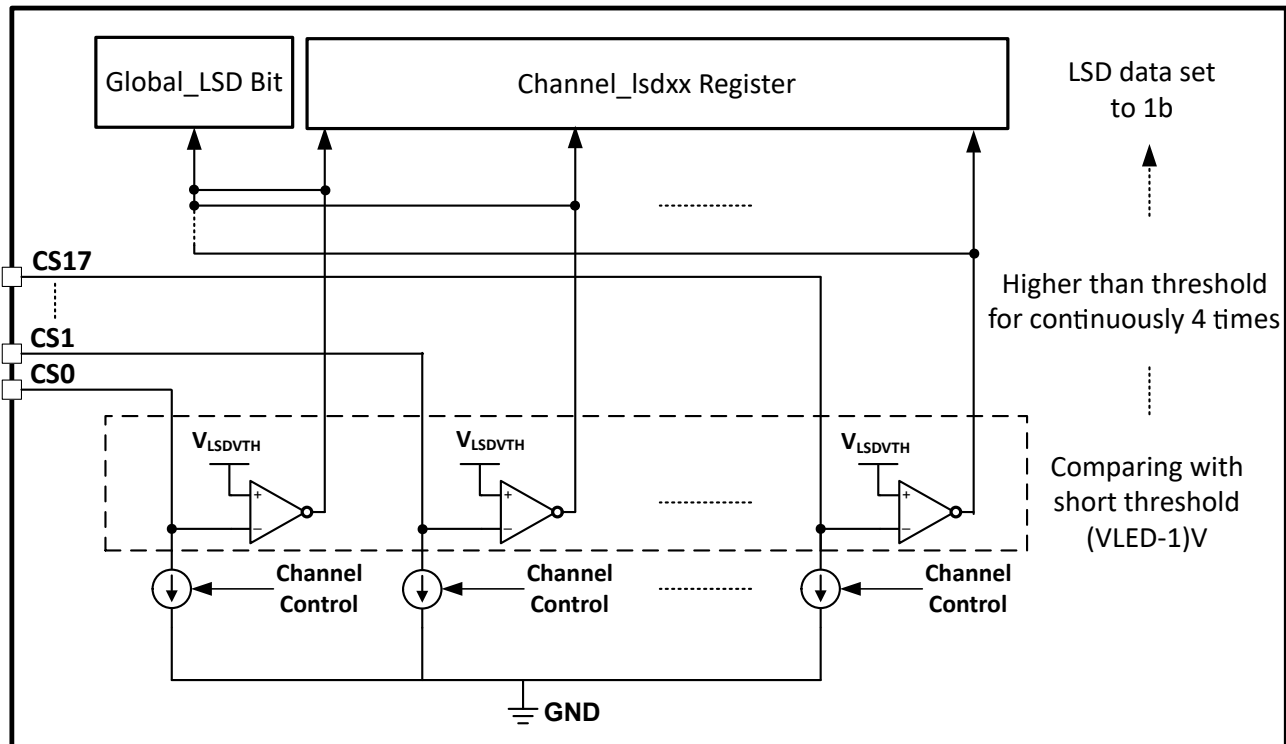
The LP5868T has an internal comparator that monitors the voltage at VCC. When VCC is below V_{UVF} , reset is active and the LP5868T enters INITIALIZATION state.

7.4 Device Functional Modes



図 7-13. Device Functional Modes

- SHUTDOWN: The device enters into SHUTDOWN mode from all states on VCC power up or EN pin is low.
- HARDWARE POR: The device enters into HARDWARE POR when Enable pin is high or VCC fall under V_{UVF} causing UVLO=H from all states.
- SOFTWARE RESET: The device enters into SOFTWARE RESET mode when VCC rise higher than V_{UVR} with the time $t > t_{POR_H}$. In this mode, all the registers are reset. Entry can also be from any state when the RESET (register) = FFh or UVLO is low.
- STANDBY: The device enters the STANDBY mode when Chip_EN (register) = 0. In this mode, device enters into low power mode, but the I²C/SPI are still available for Chip_EN only and the registers' data are retained.
- NORMAL: The device enters the NORMAL mode when 'Chip_EN' = 1 with the time $t > t_{CHIP_EN}$.
- THERMAL SHUTDOWN: The device automatically enters the THERMAL SHUTDOWN mode when the junction temperature exceeds 160°C (typical). If the junction temperature decreases below 145°C (typical), the device returns to the NORMAL mode.

7.5 Programming

7.5.1 Interface Selection

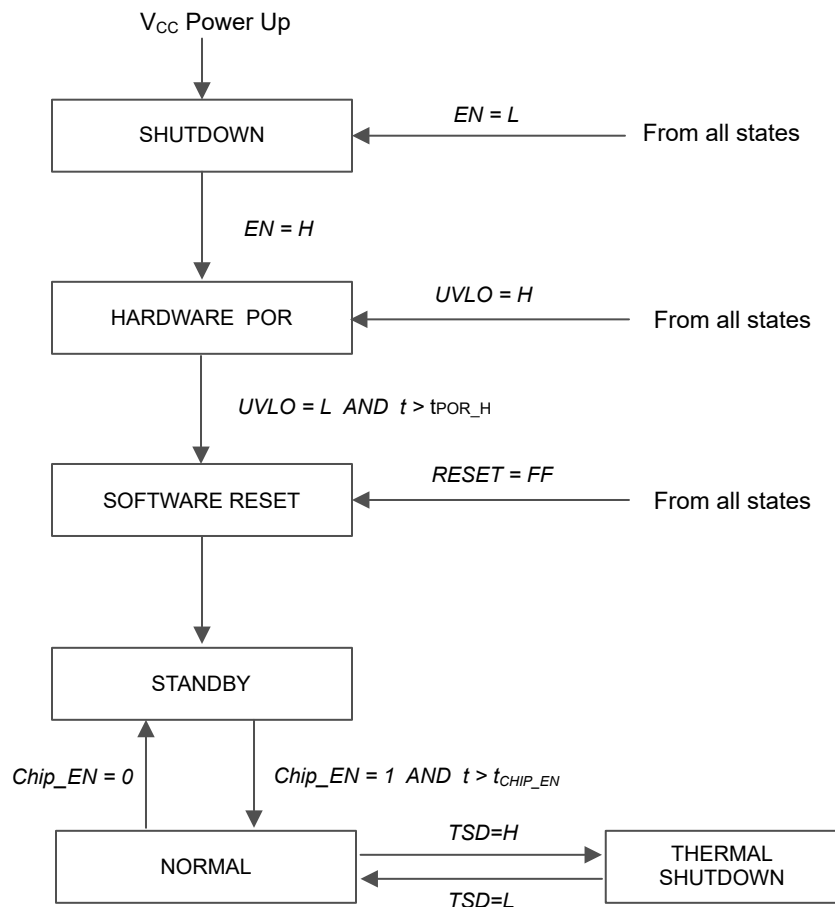
The LP5868T supports two communication interfaces: I²C and SPI. If IFS is high, the device enters into SPI mode. If IFS is low, the device enters into I²C mode.

表 7-5. Interface Selection

INTERFACE TYPE	ENTRY CONDITION
I ² C	IFS = Low
SPI	IFS = High

7.5.2 I²C Interface

The LP5868T is compatible with I²C standard specification. The device supports both fast mode (400KHz maximum) and fast plus mode (1MHz maximum).

7.5.2.1 I²C Data Transactions

The data on SDA line must be stable during the HIGH period of the clock signal (SCL). In other words, state of the data line can only be changed when clock signal is LOW. START and STOP conditions classify the beginning and the end of the data transfer session. A START condition is defined as the SDA signal transitioning from HIGH to LOW while SCL line is HIGH. A STOP condition is defined as the SDA transitioning from LOW to HIGH while SCL is HIGH. The bus leader always generates START and STOP conditions. The bus is considered to be busy after a START condition and free after a STOP condition. During data transmission, the bus leader can generate repeated START conditions. First START and repeated START conditions are functionally equivalent.

Each byte of data has to be followed by an acknowledge bit. The acknowledge related clock pulse is generated by the leader. The leader releases the SDA line (HIGH) during the acknowledge clock pulse. The device pulls down the SDA line during the 9th clock pulse, signifying an acknowledge. The device generates an acknowledge after each byte has been received.

There is one exception to the acknowledge after every byte rule. When the leader is the receiver, it must indicate to the transmitter an end of data by not acknowledging (*negative acknowledge*) the last byte clocked out of the follower. This negative acknowledge still includes the acknowledge clock pulse (generated by the leader), but the SDA line is not pulled down.

7.5.2.2 I²C Data Format

The address and data bits are transmitted MSB first with 8-bits length format in each cycle. Each transmission is started with Address Byte 1, which are divided into 5-bits of the chip address, 2 higher bits of the register address, and 1 read/write bit. The other 8 lower bits of register address are put in Address Byte 2. The device supports both independent mode and broadcast mode. The auto-increment feature allows writing / reading several consecutive registers within one transmission. If not consecutive, a new transmission must be started.

表 7-6. I²C Data Format

Address Byte1	Chip Address					Register Address		R/W
	Bit 7	Bit 6	Bit 5	Bit 4	Bit 3	Bit 2	Bit 1	Bit 0
Independent	1	0	0	ADDR1	ADDR0	9 th bit	8 th bit	R: 1 W: 0
Broadcast	1	0	1	0	1			
Address Byte2	Register Address							
	Bit 7	Bit 6	Bit 5	Bit 4	Bit 3	Bit 2	Bit 1	Bit 0
	7 th bit	6 th bit	5 th bit	4 th bit	3 th bit	2 th bit	1 th bit	0 th bit



図 7-14. I²C Write Timing



図 7-15. I²C Read Timing

7.5.2.3 Multiple Devices Connection

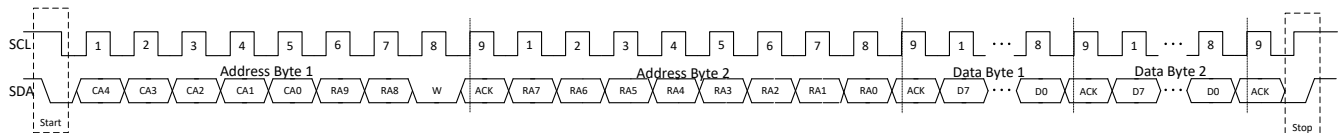
The LP5868T enters into I²C mode if IFS is connected to GND. The ADDR0/1 pin is used to select the unique I²C follower address for each device. The SCL and SDA lines must each have a pullup resistor (4.7KΩ for 400KHz, 2KΩ for 1MHz) placed somewhere on the line and remain HIGH even when the bus is idle. VIO_EN can either be connected with VIO power supply or GPIO. It's suggested to put one 1nF cap as closer to VIO_EN pin as possible. Up to four LP5868T follower devices can share the same I²C bus by the different ADDR configurations.

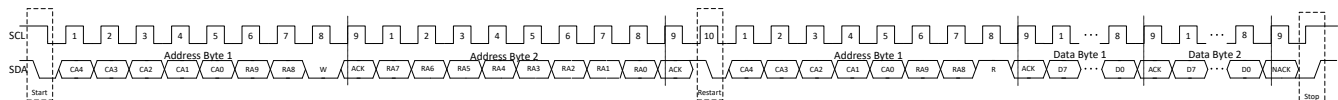
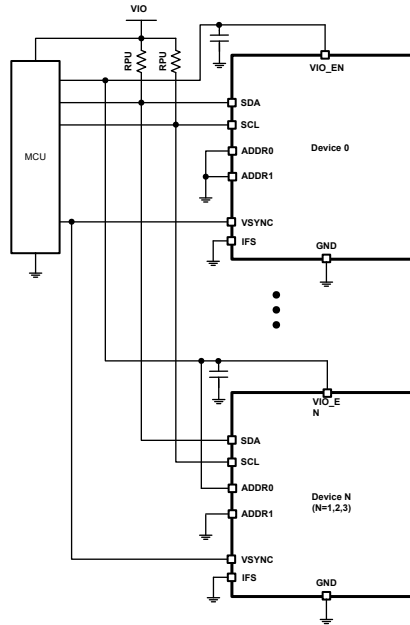

 7-16. I²C Multiple Devices Connection

7.5.3 Programming

7.5.3.1 SPI Data Transactions

MISO output is normally in a high impedance state. When the follower-select pin SS for the device is active (low) the MISO output is pulled low for read only. During write cycle MISO stays in high-impedance state. The follower-select signal SS must be low during the cycle transmission. SS resets the interface when high. Data is clocked in on the rising edge of the SCLK clock signal, while data is clocked out on the falling edge of SCLK.

7.5.3.2 SPI Data Format

The address and data bits are transmitted MSB first with 8-bits length format in each cycle. Each transmission is started with Address Byte 1, which contains 8 higher bits of the register address. The Address Byte 2 is started with 2 lower bits of the register address and 1 read/write bit. The auto-increment feature allows writing / reading several consecutive registers within one transmission. If not consecutive, a new transmission must be started.

表 7-7. SPI Data Format

Address Byte1	Register Address								
	Bit 7	Bit 6	Bit 5	Bit 4	Bit 3	Bit 2	Bit 1	Bit 0	
	9 th bit	8 th bit	7 th bit	6 th bit	5 th bit	4 th bit	3 th bit	2 th bit	
Address Byte2	Register Address								
	Bit 7	Bit 6	Bit 5	Bit 4	Bit 3	Bit 2	Bit 1	Bit 0	
	1 th bit	0 th bit	R: 0 W: 1	Don't Care					



図 7-17. SPI Write Timing



図 7-18. SPI Read Timing

7.5.3.3 Multiple Devices Connection

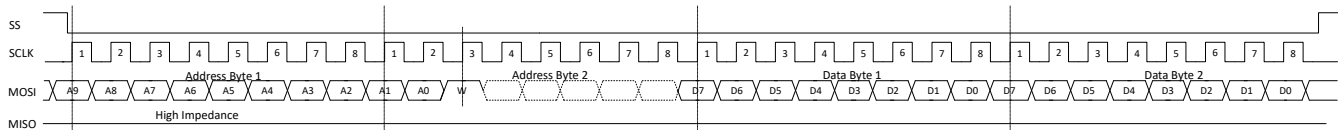
The device enters into SPI mode if IFS is pulled high to VIO through a pullup resistor(4.7KΩ recommended). VIO_EN can either be connected with VIO power supply or GPIO. It's suggested to put one 1nF cap as closer to VIO_EN pin as possible. In SPI mode host can address as many devices as there are follower select pins on host.

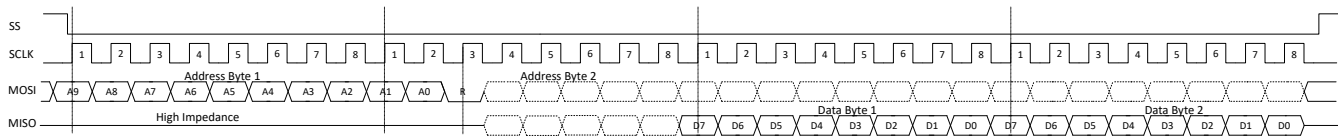
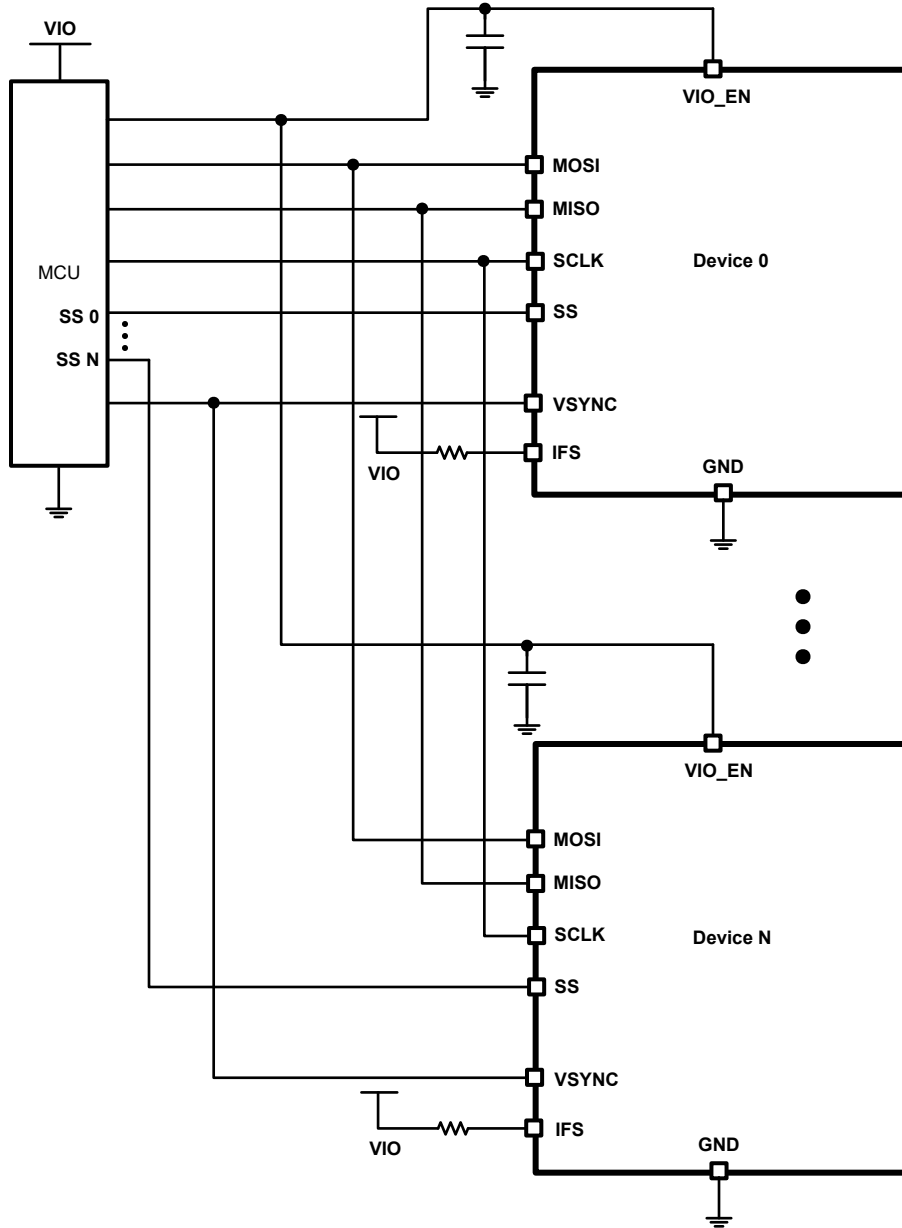

 7-19. SPI Multiple Devices Connection

7.6 Register Maps

This section provides a summary of the register maps. For detailed register functions and descriptions, please refer to [LP5868T 11x18 LED Matrix Driver Register Maps](#).

表 7-8. Register Section/Block Access Type Codes

Access Type	Code	Description
Read Type		
R	R	Read
RC	R C	Read to Clear
R-0	R -0	Read Returns 0
Write Type		
W	W	Write
W0CP	W 0C P	W 0 to clear Requires privileged access
Reset or Default Value		
-n		Value after reset or the default value

Register Acronym	Address	Type	D7	D6	D5	D4	D3	D2	D1	D0	Default	
Chip_en	000h	R/W	Reserved								Chip_EN	00h
Dev_initial	001h	R/W	Reserved	Max_Line_Num				Data_Ref_Mode		PWM_Fre	5Eh	
Dev_config1	002h	R/W	Reserved	Reserved	Reserved	Reserved	SW_BLK	PWM_Sc ale_Mode	PWM_Ph ase_Shift	CS_ON_ Shift	00h	
Dev_config2	003h	R/W	Comp_Group3		Comp_Group2		Comp_Group1		LOD_rem oval	LSD_rem oval	00h	
Dev_config3	004h	R/W	Down_Deghost		Up_Deghost		Maximum_Current		Up_Degh ost_enabl e		47h	
Global_bri	005h	R/W	PWM_Global								FFh	
Group0_bri	006h	R/W	PWM_Group1								FFh	
Group1_bri	007h	R/W	PWM_Group2								FFh	
Group2_bri	008h	R/W	PWM_Group3								FFh	
R_current_set	009h	R/W	Reserved	CC_Group1							40h	
G_current_set	00Ah	R/W	Reserved	CC_Group2							40h	
B_current_set	00Bh	R/W	Reserved	CC_Group3							40h	
Dot_grp_sel0	00Ch	R/W	Dot L0-CS3 group		Dot L0-CS2 group		Dot L0-CS1 group		Dot L0-CS0 group		00h	
Dot_grp_sel1	00Dh	R/W	Dot L0-CS7 group		Dot L0-CS6 group		Dot L0-CS5 group		Dot L0-CS4 group		00h	
Dot_grp_sel2	00Eh	R/W	Dot L0-CS11 group		Dot L0-CS10 group		Dot L0-CS9 group		Dot L0-CS8 group		00h	
Dot_grp_sel3	00Fh	R/W	Dot L0-CS15 group		Dot L0-CS14 group		Dot L0-CS13 group		Dot L0-CS12 group		00h	
Dot_grp_sel4	010h	R/W	Reserved				Dot L0-CS17 group		Dot L0-CS16 group		00h	
Dot_grp_sel5	011h	R/W	Dot L1-CS3 group		Dot L1-CS2 group		Dot L1-CS1 group		Dot L1-CS0 group		00h	
Dot_grp_sel6	012h	R/W	Dot L1-CS7 group		Dot L1-CS6 group		Dot L1-CS5 group		Dot L1-CS4 group		00h	
Dot_grp_sel7	013h	R/W	Dot L1-CS11 group		Dot L1-CS10 group		Dot L1-CS9 group		Dot L1-CS8 group		00h	
Dot_grp_sel8	014h	R/W	Dot L1-CS15 group		Dot L1-CS14 group		Dot L1-CS13 group		Dot L1-CS12 group		00h	
Dot_grp_sel9	015h	R/W	Reserved				Dot L1-CS17 group		Dot L1-CS16 group		00h	
Dot_grp_sel10	016h	R/W	Dot L2-CS3 group		Dot L2-CS2 group		Dot L2-CS1 group		Dot L2-CS0 group		00h	

Register Acronym	Address	Type	D7	D6	D5	D4	D3	D2	D1	D0	Default
Dot_grp_sel11	017h	R/W	Dot L2-CS7 group		Dot L2-CS6 group		Dot L2-CS5 group		Dot L2-CS4 group		00h
Dot_grp_sel12	018h	R/W	Dot L2-CS11 group		Dot L2-CS10 group		Dot L2-CS9 group		Dot L2-CS8 group		00h
Dot_grp_sel13	019h	R/W	Dot L2-CS15 group		Dot L2-CS14 group		Dot L2-CS13 group		Dot L2-CS12 group		00h
Dot_grp_sel14	01Ah	R/W	Reserved				Dot L2-CS17 group		Dot L2-CS16 group		00h
Dot_grp_sel15	01Bh	R/W	Dot L3-CS3 group		Dot L3-CS2 group		Dot L3-CS1 group		Dot L3-CS0 group		00h
Dot_grp_sel16	01Ch	R/W	Dot L3-CS7 group		Dot L3-CS6 group		Dot L3-CS5 group		Dot L3-CS4 group		00h
Dot_grp_sel17	01Dh	R/W	Dot L3-CS11 group		Dot L3-CS10 group		Dot L3-CS9 group		Dot L3-CS8 group		00h
Dot_grp_sel18	01Eh	R/W	Dot L3-CS15 group		Dot L3-CS14 group		Dot L3-CS13 group		Dot L3-CS12 group		00h
Dot_grp_sel19	01Fh	R/W	Reserved				Dot L3-CS17 group		Dot L3-CS16 group		00h
Dot_grp_sel20	020h	R/W	Dot L4-CS3 group		Dot L4-CS2 group		Dot L4-CS1 group		Dot L4-CS0 group		00h
Dot_grp_sel21	021h	R/W	Dot L4-CS7 group		Dot L4-CS6 group		Dot L4-CS5 group		Dot L4-CS4 group		00h
Dot_grp_sel22	022h	R/W	Dot L4-CS11 group		Dot L4-CS10 group		Dot L4-CS9 group		Dot L4-CS8 group		00h
Dot_grp_sel23	023h	R/W	Dot L4-CS15 group		Dot L4-CS14 group		Dot L4-CS13 group		Dot L4-CS12 group		00h
Dot_grp_sel24	024h	R/W	Reserved				Dot L4-CS17 group		Dot L4-CS16 group		00h
Dot_grp_sel25	025h	R/W	Dot L5-CS3 group		Dot L5-CS2 group		Dot L5-CS1 group		Dot L5-CS0 group		00h
Dot_grp_sel26	026h	R/W	Dot L5-CS7 group		Dot L5-CS6 group		Dot L5-CS5 group		Dot L5-CS4 group		00h
Dot_grp_sel27	027h	R/W	Dot L5-CS11 group		Dot L5-CS10 group		Dot L5-CS9 group		Dot L5-CS8 group		00h
Dot_grp_sel28	028h	R/W	Dot L5-CS15 group		Dot L5-CS14 group		Dot L5-CS13 group		Dot L5-CS12 group		00h
Dot_grp_sel29	029h	R/W	Reserved				Dot L5-CS17 group		Dot L5-CS16 group		00h
Dot_grp_sel30	02Ah	R/W	Dot L6-CS3 group		Dot L6-CS2 group		Dot L6-CS1 group		Dot L6-CS0 group		00h
Dot_grp_sel31	02Bh	R/W	Dot L6-CS7 group		Dot L6-CS6 group		Dot L6-CS5 group		Dot L6-CS4 group		00h
Dot_grp_sel32	02Ch	R/W	Dot L6-CS11 group		Dot L6-CS10 group		Dot L6-CS9 group		Dot L6-CS8 group		00h
Dot_grp_sel33	02Dh	R/W	Dot L6-CS15 group		Dot L6-CS14 group		Dot L6-CS13 group		Dot L6-CS12 group		00h
Dot_grp_sel34	02Eh	R/W	Reserved				Dot L6-CS17 group		Dot L6-CS16 group		00h
Dot_grp_sel35	02Fh	R/W	Dot L7-CS3 group		Dot L7-CS2 group		Dot L7-CS1 group		Dot L7-CS0 group		00h
Dot_grp_sel36	030h	R/W	Dot L7-CS7 group		Dot L7-CS6 group		Dot L7-CS5 group		Dot L7-CS4 group		00h
Dot_grp_sel37	031h	R/W	Dot L7-CS11 group		Dot L7-CS10 group		Dot L7-CS9 group		Dot L7-CS8 group		00h
Dot_grp_sel38	032h	R/W	Dot L7-CS15 group		Dot L7-CS14 group		Dot L7-CS13 group		Dot L7-CS12 group		00h
Dot_grp_sel39	033h	R/W	Reserved				Dot L7-CS17 group		Dot L7-CS16 group		00h
Dot_onoff0	043h	R/W	Dot L0-CS7 onoff	Dot L0-CS6 onoff	Dot L0-CS5 onoff	Dot L0-CS4 onoff	Dot L0-CS3 onoff	Dot L0-CS2 onoff	Dot L0-CS1 onoff	Dot L0-CS0 onoff	FFh
Dot_onoff1	044h	R/W	Dot L0-CS15 onoff	Dot L0-CS14 onoff	Dot L0-CS13 onoff	Dot L0-CS12 onoff	Dot L0-CS11 onoff	Dot L0-CS10 onoff	Dot L0-CS9 onoff	Dot L0-CS8 onoff	FFh
Dot_onoff2	045h	R/W	Reserved						Dot L0-CS17 onoff	Dot L0-CS16 onoff	03h
Dot_onoff3	046h	R/W	Dot L1-CS7 onoff	Dot L1-CS6 onoff	Dot L1-CS5 onoff	Dot L1-CS4 onoff	Dot L1-CS3 onoff	Dot L1-CS2 onoff	Dot L1-CS1 onoff	Dot L1-CS0 onoff	FFh
Dot_onoff4	047h	R/W	Dot L1-CS15 onoff	Dot L1-CS14 onoff	Dot L1-CS13 onoff	Dot L1-CS12 onoff	Dot L1-CS11 onoff	Dot L1-CS10 onoff	Dot L1-CS9 onoff	Dot L1-CS8 onoff	FFh
Dot_onoff5	048h	R/W	Reserved						Dot L1-CS17 onoff	Dot L1-CS16 onoff	03h
Dot_onoff6	049h	R/W	Dot L2-CS7 onoff	Dot L2-CS6 onoff	Dot L2-CS5 onoff	Dot L2-CS4 onoff	Dot L2-CS3 onoff	Dot L2-CS2 onoff	Dot L2-CS1 onoff	Dot L2-CS0 onoff	FFh

Register Acronym	Address	Type	D7	D6	D5	D4	D3	D2	D1	D0	Default
Dot_onoff7	04Ah	R/W	Dot L2-CS15 onoff	Dot L2-CS14 onoff	Dot L2-CS13 onoff	Dot L2-CS12 onoff	Dot L2-CS11 onoff	Dot L2-CS10 onoff	Dot L2-CS9 onoff	Dot L2-CS8 onoff	FFh
Dot_onoff8	04Bh	R/W	Reserved						Dot L2-CS17 onoff	Dot L2-CS16 onoff	03h
Dot_onoff9	04Ch	R/W	Dot L3-CS7 onoff	Dot L3-CS6 onoff	Dot L3-CS5 onoff	Dot L3-CS4 onoff	Dot L3-CS3 onoff	Dot L3-CS2 onoff	Dot L3-CS1 onoff	Dot L3-CS0 onoff	FFh
Dot_onoff10	04Dh	R/W	Dot L3-CS15 onoff	Dot L3-CS14 onoff	Dot L3-CS13 onoff	Dot L3-CS12 onoff	Dot L3-CS11 onoff	Dot L3-CS10 onoff	Dot L3-CS9 onoff	Dot L3-CS8 onoff	FFh
Dot_onoff11	04Eh	R/W	Reserved						Dot L3-CS17 onoff	Dot L3-CS16 onoff	03h
Dot_onoff12	04Fh	R/W	Dot L4-CS7 onoff	Dot L4-CS6 onoff	Dot L4-CS5 onoff	Dot L4-CS4 onoff	Dot L4-CS3 onoff	Dot L4-CS2 onoff	Dot L4-CS1 onoff	Dot L4-CS0 onoff	FFh
Dot_onoff13	050h	R/W	Dot L4-CS15 onoff	Dot L4-CS14 onoff	Dot L4-CS13 onoff	Dot L4-CS12 onoff	Dot L4-CS11 onoff	Dot L4-CS10 onoff	Dot L4-CS9 onoff	Dot L4-CS8 onoff	FFh
Dot_onoff14	051h	R/W	Reserved						Dot L4-CS17 onoff	Dot L4-CS16 onoff	03h
Dot_onoff15	052h	R/W	Dot L5-CS7 onoff	Dot L5-CS6 onoff	Dot L5-CS5 onoff	Dot L5-CS4 onoff	Dot L5-CS3 onoff	Dot L5-CS2 onoff	Dot L5-CS1 onoff	Dot L5-CS0 onoff	FFh
Dot_onoff16	053h	R/W	Dot L5-CS15 onoff	Dot L5-CS14 onoff	Dot L5-CS13 onoff	Dot L5-CS12 onoff	Dot L5-CS11 onoff	Dot L5-CS10 onoff	Dot L5-CS9 onoff	Dot L5-CS8 onoff	FFh
Dot_onoff17	054h	R/W	Reserved						Dot L5-CS17 onoff	Dot L5-CS16 onoff	03h
Dot_onoff18	055h	R/W	Dot L6-CS7 onoff	Dot L6-CS6 onoff	Dot L6-CS5 onoff	Dot L6-CS4 onoff	Dot L6-CS3 onoff	Dot L6-CS2 onoff	Dot L6-CS1 onoff	Dot L6-CS0 onoff	FFh
Dot_onoff19	056h	R/W	Dot L6-CS15 onoff	Dot L6-CS14 onoff	Dot L6-CS13 onoff	Dot L6-CS12 onoff	Dot L6-CS11 onoff	Dot L6-CS10 onoff	Dot L6-CS9 onoff	Dot L6-CS8 onoff	FFh
Dot_onoff20	057h	R/W	Reserved						Dot L6-CS17 onoff	Dot L6-CS16 onoff	03h
Dot_onoff21	058h	R/W	Dot L7-CS7 onoff	Dot L7-CS6 onoff	Dot L7-CS5 onoff	Dot L7-CS4 onoff	Dot L7-CS3 onoff	Dot L7-CS2 onoff	Dot L7-CS1 onoff	Dot L7-CS0 onoff	FFh
Dot_onoff22	059h	R/W	Dot L7-CS15 onoff	Dot L7-CS14 onoff	Dot L7-CS13 onoff	Dot L7-CS12 onoff	Dot L7-CS11 onoff	Dot L7-CS10 onoff	Dot L7-CS9 onoff	Dot L7-CS8 onoff	FFh
Dot_onoff23	05Ah	R/W	Reserved						Dot L7-CS17 onoff	Dot L7-CS16 onoff	03h
Fault_state	064h	R	Reserved						Global_L OD	Global_L SD	00h
Dot_lod0	065h	R	Dot L0-CS7 LOD	Dot L0-CS6 LOD	Dot L0-CS5 LOD	Dot L0-CS4 LOD	Dot L0-CS3 LOD	Dot L0-CS2 LOD	Dot L0-CS1 LOD	Dot L0-CS0 LOD	00h
Dot_lod1	066h	R	Dot L0-CS15 LOD	Dot L0-CS14 LOD	Dot L0-CS13 LOD	Dot L0-CS12 LOD	Dot L0-CS11 LOD	Dot L0-CS10 LOD	Dot L0-CS9 LOD	Dot L0-CS8 LOD	00h
Dot_lod2	067h	R	Reserved						Dot L0-CS17 LOD	Dot L0-CS16 LOD	00h

Register Acronym	Address	Type	D7	D6	D5	D4	D3	D2	D1	D0	Default
Dot_lod3	068h	R	Dot L1- CS7 LOD	Dot L1- CS6 LOD	Dot L1- CS5 LOD	Dot L1- CS4 LOD	Dot L1- CS3 LOD	Dot L1- CS2 LOD	Dot L1- CS1 LOD	Dot L1- CS0 LOD	00h
Dot_lod4	069h	R	Dot L1- CS15 LOD	Dot L1- CS14 LOD	Dot L1- CS13 LOD	Dot L1- CS12 LOD	Dot L1- CS11 LOD	Dot L1- CS10 LOD	Dot L1- CS9 LOD	Dot L1- CS8 LOD	00h
Dot_lod5	06Ah	R	Reserved						Dot L1- CS17 LOD	Dot L1- CS16 LOD	00h
Dot_lod6	06Bh	R	Dot L2- CS7 LOD	Dot L2- CS6 LOD	Dot L2- CS5 LOD	Dot L2- CS4 LOD	Dot L2- CS3 LOD	Dot L2- CS2 LOD	Dot L2- CS1 LOD	Dot L2- CS0 LOD	00h
Dot_lod7	06Ch	R	Dot L2- CS15 LOD	Dot L2- CS14 LOD	Dot L2- CS13 LOD	Dot L2- CS12 LOD	Dot L2- CS11 LOD	Dot L2- CS10 LOD	Dot L2- CS9 LOD	Dot L2- CS8 LOD	00h
Dot_lod8	06Dh	R	Reserved						Dot L2- CS17 LOD	Dot L2- CS16 LOD	00h
Dot_lod9	06Eh	R	Dot L3- CS7 LOD	Dot L3- CS6 LOD	Dot L3- CS5 LOD	Dot L3- CS4 LOD	Dot L3- CS3 LOD	Dot L3- CS2 LOD	Dot L3- CS1 LOD	Dot L3- CS0 LOD	00h
Dot_lod10	06Fh	R	Dot L3- CS15 LOD	Dot L3- CS14 LOD	Dot L3- CS13 LOD	Dot L3- CS12 LOD	Dot L3- CS11 LOD	Dot L3- CS10 LOD	Dot L3- CS9 LOD	Dot L3- CS8 LOD	00h
Dot_lod11	070h	R	Reserved						Dot L3- CS17 LOD	Dot L3- CS16 LOD	00h
Dot_lod12	071h	R	Dot L4- CS7 LOD	Dot L4- CS6 LOD	Dot L4- CS5 LOD	Dot L4- CS4 LOD	Dot L4- CS3 LOD	Dot L4- CS2 LOD	Dot L4- CS1 LOD	Dot L4- CS0 LOD	00h
Dot_lod13	072h	R	Dot L4- CS15 LOD	Dot L4- CS14 LOD	Dot L4- CS13 LOD	Dot L4- CS12 LOD	Dot L4- CS11 LOD	Dot L4- CS10 LOD	Dot L4- CS9 LOD	Dot L4- CS8 LOD	00h
Dot_lod14	073h	R	Reserved						Dot L4- CS17 LOD	Dot L4- CS16 LOD	00h
Dot_lod15	074h	R	Dot L5- CS7 LOD	Dot L5- CS6 LOD	Dot L5- CS5 LOD	Dot L5- CS4 LOD	Dot L5- CS3 LOD	Dot L5- CS2 LOD	Dot L5- CS1 LOD	Dot L5- CS0 LOD	00h
Dot_lod16	075h	R	Dot L5- CS15 LOD	Dot L5- CS14 LOD	Dot L5- CS13 LOD	Dot L5- CS12 LOD	Dot L5- CS11 LOD	Dot L5- CS10 LOD	Dot L5- CS9 LOD	Dot L5- CS8 LOD	00h
Dot_lod17	076h	R	Reserved						Dot L5- CS17 LOD	Dot L5- CS16 LOD	00h
Dot_lod18	077h	R	Dot L6- CS7 LOD	Dot L6- CS6 LOD	Dot L6- CS5 LOD	Dot L6- CS4 LOD	Dot L6- CS3 LOD	Dot L6- CS2 LOD	Dot L6- CS1 LOD	Dot L6- CS0 LOD	00h
Dot_lod19	078h	R	Dot L6- CS15 LOD	Dot L6- CS14 LOD	Dot L6- CS13 LOD	Dot L6- CS12 LOD	Dot L6- CS11 LOD	Dot L6- CS10 LOD	Dot L6- CS9 LOD	Dot L6- CS8 LOD	00h
Dot_lod20	079h	R	Reserved						Dot L6- CS17 LOD	Dot L6- CS16 LOD	00h
Dot_lod21	07Ah	R	Dot L7- CS7 LOD	Dot L7- CS6 LOD	Dot L7- CS5 LOD	Dot L7- CS4 LOD	Dot L7- CS3 LOD	Dot L7- CS2 LOD	Dot L7- CS1 LOD	Dot L7- CS0 LOD	00h
Dot_lod22	07Bh	R	Dot L7- CS15 LOD	Dot L7- CS14 LOD	Dot L7- CS13 LOD	Dot L7- CS12 LOD	Dot L7- CS11 LOD	Dot L7- CS10 LOD	Dot L7- CS9 LOD	Dot L7- CS8 LOD	00h
Dot_lod23	07Ch	R	Reserved						Dot L7- CS17 LOD	Dot L7- CS16 LOD	00h

Register Acronym	Address	Type	D7	D6	D5	D4	D3	D2	D1	D0	Default
Dot_Isd0	086h	R	Dot L0-CS7 LSD	Dot L0-CS6 LSD	Dot L0-CS5 LSD	Dot L0-CS4 LSD	Dot L0-CS3 LSD	Dot L0-CS2 LSD	Dot L0-CS1 LSD	Dot L0-CS0 LSD	00h
Dot_Isd1	087h	R	Dot L0-CS15 LSD	Dot L0-CS14 LSD	Dot L0-CS13 LSD	Dot L0-CS12 LSD	Dot L0-CS11 LSD	Dot L0-CS10 LSD	Dot L0-CS9 LSD	Dot L0-CS8 LSD	00h
Dot_Isd2	088h	R	Reserved						Dot L0-CS17 LSD	Dot L0-CS16 LSD	00h
Dot_Isd3	089h	R	Dot L1-CS7 LSD	Dot L1-CS6 LSD	Dot L1-CS5 LSD	Dot L1-CS4 LSD	Dot L1-CS3 LSD	Dot L1-CS2 LSD	Dot L1-CS1 LSD	Dot L1-CS0 LSD	00h
Dot_Isd4	08Ah	R	Dot L1-CS15 LSD	Dot L1-CS14 LSD	Dot L1-CS13 LSD	Dot L1-CS12 LSD	Dot L1-CS11 LSD	Dot L1-CS10 LSD	Dot L1-CS9 LSD	Dot L1-CS8 LSD	00h
Dot_Isd5	08Bh	R	Reserved						Dot L1-CS17 LSD	Dot L1-CS16 LSD	00h
Dot_Isd6	08Ch	R	Dot L2-CS7 LSD	Dot L2-CS6 LSD	Dot L2-CS5 LSD	Dot L2-CS4 LSD	Dot L2-CS3 LSD	Dot L2-CS2 LSD	Dot L2-CS1 LSD	Dot L2-CS0 LSD	00h
Dot_Isd7	08Dh	R	Dot L2-CS15 LSD	Dot L2-CS14 LSD	Dot L2-CS13 LSD	Dot L2-CS12 LSD	Dot L2-CS11 LSD	Dot L2-CS10 LSD	Dot L2-CS9 LSD	Dot L2-CS8 LSD	00h
Dot_Isd8	08Eh	R	Reserved						Dot L2-CS17 LSD	Dot L2-CS16 LSD	00h
Dot_Isd9	08Fh	R	Dot L3-CS7 LSD	Dot L3-CS6 LSD	Dot L3-CS5 LSD	Dot L3-CS4 LSD	Dot L3-CS3 LSD	Dot L3-CS2 LSD	Dot L3-CS1 LSD	Dot L3-CS0 LSD	00h
Dot_Isd10	090h	R	Dot L3-CS15 LSD	Dot L3-CS14 LSD	Dot L3-CS13 LSD	Dot L3-CS12 LSD	Dot L3-CS11 LSD	Dot L3-CS10 LSD	Dot L3-CS9 LSD	Dot L3-CS8 LSD	00h
Dot_Isd11	091h	R	Reserved						Dot L3-CS17 LSD	Dot L3-CS16 LSD	00h
Dot_Isd12	092h	R	Dot L4-CS7 LSD	Dot L4-CS6 LSD	Dot L4-CS5 LSD	Dot L4-CS4 LSD	Dot L4-CS3 LSD	Dot L4-CS2 LSD	Dot L4-CS1 LSD	Dot L4-CS0 LSD	00h
Dot_Isd13	093h	R	Dot L4-CS15 LSD	Dot L4-CS14 LSD	Dot L4-CS13 LSD	Dot L4-CS12 LSD	Dot L4-CS11 LSD	Dot L4-CS10 LSD	Dot L4-CS9 LSD	Dot L4-CS8 LSD	00h
Dot_Isd14	094h	R	Reserved						Dot L4-CS17 LSD	Dot L4-CS16 LSD	00h
Dot_Isd15	095h	R	Dot L5-CS7 LSD	Dot L5-CS6 LSD	Dot L5-CS5 LSD	Dot L5-CS4 LSD	Dot L5-CS3 LSD	Dot L5-CS2 LSD	Dot L5-CS1 LSD	Dot L5-CS0 LSD	00h
Dot_Isd16	096h	R	Dot L5-CS15 LSD	Dot L5-CS14 LSD	Dot L5-CS13 LSD	Dot L5-CS12 LSD	Dot L5-CS11 LSD	Dot L5-CS10 LSD	Dot L5-CS9 LSD	Dot L5-CS8 LSD	00h
Dot_Isd17	097h	R	Reserved						Dot L5-CS17 LSD	Dot L5-CS16 LSD	00h
Dot_Isd18	098h	R	Dot L6-CS7 LSD	Dot L6-CS6 LSD	Dot L6-CS5 LSD	Dot L6-CS4 LSD	Dot L6-CS3 LSD	Dot L6-CS2 LSD	Dot L6-CS1 LSD	Dot L6-CS0 LSD	00h
Dot_Isd19	099h	R	Dot L6-CS15 LSD	Dot L6-CS14 LSD	Dot L6-CS13 LSD	Dot L6-CS12 LSD	Dot L6-CS11 LSD	Dot L6-CS10 LSD	Dot L6-CS9 LSD	Dot L6-CS8 LSD	00h
Dot_Isd20	09Ah	R	Reserved						Dot L6-CS17 LSD	Dot L6-CS16 LSD	00h

Register Acronym	Address	Type	D7	D6	D5	D4	D3	D2	D1	D0	Default
Dot_Isd21	09Bh	R	Dot L7-CS7 LSD	Dot L7-CS6 LSD	Dot L7-CS5 LSD	Dot L7-CS4 LSD	Dot L7-CS3 LSD	Dot L7-CS2 LSD	Dot L7-CS1 LSD	Dot L7-CS0 LSD	00h
Dot_Isd22	09Ch	R	Dot L7-CS15 LSD	Dot L7-CS14 LSD	Dot L7-CS13 LSD	Dot L7-CS12 LSD	Dot L7-CS11 LSD	Dot L7-CS10 LSD	Dot L7-CS9 LSD	Dot L7-CS8 LSD	00h
Dot_Isd23	09Dh	R	Reserved						Dot L7-CS17 LSD	Dot L7-CS16 LSD	00h
LOD_clear	0A7h	W	Reserved				LOD_Clear				00h
LSD_clear	0A8h	W	Reserved				LSD_Clear				00h
Reset	0A9h	W	Reset								00h
DC0	100h	R/W	LED dot current setting for Dot L0-CS0								80h
DC1	101h	R/W	LED dot current setting for Dot L0-CS1								80h
DC2	102h	R/W	LED dot current setting for Dot L0-CS2								80h
DC3	103h	R/W	LED dot current setting for Dot L0-CS3								80h
DC4	104h	R/W	LED dot current setting for Dot L0-CS4								80h
DC5	105h	R/W	LED dot current setting for Dot L0-CS5								80h
DC6	106h	R/W	LED dot current setting for Dot L0-CS6								80h
DC7	107h	R/W	LED dot current setting for Dot L0-CS7								80h
DC8	108h	R/W	LED dot current setting for Dot L0-CS8								80h
DC9	109h	R/W	LED dot current setting for Dot L0-CS9								80h
DC10	10Ah	R/W	LED dot current setting for Dot L0-CS10								80h
DC11	10Bh	R/W	LED dot current setting for Dot L0-CS11								80h
DC12	10Ch	R/W	LED dot current setting for Dot L0-CS12								80h
DC13	10Dh	R/W	LED dot current setting for Dot L0-CS13								80h
DC14	10Eh	R/W	LED dot current setting for Dot L0-CS14								80h
DC15	10Fh	R/W	LED dot current setting for Dot L0-CS15								80h
DC16	110h	R/W	LED dot current setting for Dot L0-CS16								80h
DC17	111h	R/W	LED dot current setting for Dot L0-CS17								80h
DC18	112h	R/W	LED dot current setting for Dot L1-CS0								80h
DC19	113h	R/W	LED dot current setting for Dot L1-CS1								80h
DC20	114h	R/W	LED dot current setting for Dot L1-CS2								80h
DC21	115h	R/W	LED dot current setting for Dot L1-CS3								80h
DC22	116h	R/W	LED dot current setting for Dot L1-CS4								80h
DC23	117h	R/W	LED dot current setting for Dot L1-CS5								80h
DC24	118h	R/W	LED dot current setting for Dot L1-CS6								80h
DC25	119h	R/W	LED dot current setting for Dot L1-CS7								80h
DC26	11Ah	R/W	LED dot current setting for Dot L1-CS8								80h
DC27	11Bh	R/W	LED dot current setting for Dot L1-CS9								80h
DC28	11Ch	R/W	LED dot current setting for Dot L1-CS10								80h
DC29	11Dh	R/W	LED dot current setting for Dot L1-CS11								80h
DC30	11Eh	R/W	LED dot current setting for Dot L1-CS12								80h
DC31	11Fh	R/W	LED dot current setting for Dot L1-CS13								80h
DC32	120h	R/W	LED dot current setting for Dot L1-CS14								80h
DC33	121h	R/W	LED dot current setting for Dot L1-CS15								80h
DC34	122h	R/W	LED dot current setting for Dot L1-CS16								80h
DC35	123h	R/W	LED dot current setting for Dot L1-CS17								80h

LP5868T

JAJSOY3B – MAY 2023 – REVISED NOVEMBER 2023

Register Acronym	Address	Type	D7	D6	D5	D4	D3	D2	D1	D0	Default	
DC36	124h	R/W									LED dot current setting for Dot L2-CS0	80h
DC37	125h	R/W									LED dot current setting for Dot L2-CS1	80h
DC38	126h	R/W									LED dot current setting for Dot L2-CS2	80h
DC39	127h	R/W									LED dot current setting for Dot L2-CS3	80h
DC40	128h	R/W									LED dot current setting for Dot L2-CS4	80h
DC41	129h	R/W									LED dot current setting for Dot L2-CS5	80h
DC42	12Ah	R/W									LED dot current setting for Dot L2-CS6	80h
DC43	12Bh	R/W									LED dot current setting for Dot L2-CS7	80h
DC44	12Ch	R/W									LED dot current setting for Dot L2-CS8	80h
DC45	12Dh	R/W									LED dot current setting for Dot L2-CS9	80h
DC46	12Eh	R/W									LED dot current setting for Dot L2-CS10	80h
DC47	12Fh	R/W									LED dot current setting for Dot L2-CS11	80h
DC48	130h	R/W									LED dot current setting for Dot L2-CS12	80h
DC49	131h	R/W									LED dot current setting for Dot L2-CS13	80h
DC50	132h	R/W									LED dot current setting for Dot L2-CS14	80h
DC51	133h	R/W									LED dot current setting for Dot L2-CS15	80h
DC52	134h	R/W									LED dot current setting for Dot L2-CS16	80h
DC53	135h	R/W									LED dot current setting for Dot L2-CS17	80h
DC54	136h	R/W									LED dot current setting for Dot L3-CS0	80h
DC55	137h	R/W									LED dot current setting for Dot L3-CS1	80h
DC56	138h	R/W									LED dot current setting for Dot L3-CS2	80h
DC57	139h	R/W									LED dot current setting for Dot L3-CS3	80h
DC58	13Ah	R/W									LED dot current setting for Dot L3-CS4	80h
DC59	13Bh	R/W									LED dot current setting for Dot L3-CS5	80h
DC60	13Ch	R/W									LED dot current setting for Dot L3-CS6	80h
DC61	13Dh	R/W									LED dot current setting for Dot L3-CS7	80h
DC62	13Eh	R/W									LED dot current setting for Dot L3-CS8	80h
DC63	13Fh	R/W									LED dot current setting for Dot L3-CS9	80h
DC64	140h	R/W									LED dot current setting for Dot L3-CS10	80h
DC65	141h	R/W									LED dot current setting for Dot L3-CS11	80h
DC66	142h	R/W									LED dot current setting for Dot L3-CS12	80h
DC67	143h	R/W									LED dot current setting for Dot L3-CS13	80h
DC68	144h	R/W									LED dot current setting for Dot L3-CS14	80h
DC69	145h	R/W									LED dot current setting for Dot L3-CS15	80h
DC70	146h	R/W									LED dot current setting for Dot L3-CS16	80h
DC71	147h	R/W									LED dot current setting for Dot L3-CS17	80h
DC72	148h	R/W									LED dot current setting for Dot L4-CS0	80h
DC73	149h	R/W									LED dot current setting for Dot L4-CS1	80h
DC74	14Ah	R/W									LED dot current setting for Dot L4-CS2	80h
DC75	14Bh	R/W									LED dot current setting for Dot L4-CS3	80h
DC76	14Ch	R/W									LED dot current setting for Dot L4-CS4	80h
DC77	14Dh	R/W									LED dot current setting for Dot L4-CS5	80h
DC78	14Eh	R/W									LED dot current setting for Dot L4-CS6	80h
DC79	14Fh	R/W									LED dot current setting for Dot L4-CS7	80h
DC80	150h	R/W									LED dot current setting for Dot L4-CS8	80h

Register Acronym	Address	Type	D7	D6	D5	D4	D3	D2	D1	D0	Default
DC81	151h	R/W						LED dot current setting for Dot L4-CS9			80h
DC82	152h	R/W						LED dot current setting for Dot L4-CS10			80h
DC83	153h	R/W						LED dot current setting for Dot L4-CS11			80h
DC84	154h	R/W						LED dot current setting for Dot L4-CS12			80h
DC85	155h	R/W						LED dot current setting for Dot L4-CS13			80h
DC86	156h	R/W						LED dot current setting for Dot L4-CS14			80h
DC87	157h	R/W						LED dot current setting for Dot L4-CS15			80h
DC88	158h	R/W						LED dot current setting for Dot L4-CS16			80h
DC89	159h	R/W						LED dot current setting for Dot L4-CS17			80h
DC90	15Ah	R/W						LED dot current setting for Dot L5-CS0			80h
DC91	15Bh	R/W						LED dot current setting for Dot L5-CS1			80h
DC92	15Ch	R/W						LED dot current setting for Dot L5-CS2			80h
DC93	15Dh	R/W						LED dot current setting for Dot L5-CS3			80h
DC94	15Eh	R/W						LED dot current setting for Dot L5-CS4			80h
DC95	15Fh	R/W						LED dot current setting for Dot L5-CS5			80h
DC96	160h	R/W						LED dot current setting for Dot L5-CS6			80h
DC97	161h	R/W						LED dot current setting for Dot L5-CS7			80h
DC98	162h	R/W						LED dot current setting for Dot L5-CS8			80h
DC99	163h	R/W						LED dot current setting for Dot L5-CS9			80h
DC100	164h	R/W						LED dot current setting for Dot L5-CS10			80h
DC101	165h	R/W						LED dot current setting for Dot L5-CS11			80h
DC102	166h	R/W						LED dot current setting for Dot L5-CS12			80h
DC103	167h	R/W						LED dot current setting for Dot L5-CS13			80h
DC104	168h	R/W						LED dot current setting for Dot L5-CS14			80h
DC105	169h	R/W						LED dot current setting for Dot L5-CS15			80h
DC106	16Ah	R/W						LED dot current setting for Dot L5-CS16			80h
DC107	16Bh	R/W						LED dot current setting for Dot L5-CS17			80h
DC108	16Ch	R/W						LED dot current setting for Dot L6-CS0			80h
DC109	16Dh	R/W						LED dot current setting for Dot L6-CS1			80h
DC110	16Eh	R/W						LED dot current setting for Dot L6-CS2			80h
DC111	16Fh	R/W						LED dot current setting for Dot L6-CS3			80h
DC112	170h	R/W						LED dot current setting for Dot L6-CS4			80h
DC113	171h	R/W						LED dot current setting for Dot L6-CS5			80h
DC114	172h	R/W						LED dot current setting for Dot L6-CS6			80h
DC115	173h	R/W						LED dot current setting for Dot L6-CS7			80h
DC116	174h	R/W						LED dot current setting for Dot L6-CS8			80h
DC117	175h	R/W						LED dot current setting for Dot L6-CS9			80h
DC118	176h	R/W						LED dot current setting for Dot L6-CS10			80h
DC119	177h	R/W						LED dot current setting for Dot L6-CS11			80h
DC120	178h	R/W						LED dot current setting for Dot L6-CS12			80h
DC121	179h	R/W						LED dot current setting for Dot L6-CS13			80h
DC122	17Ah	R/W						LED dot current setting for Dot L6-CS14			80h
DC123	17Bh	R/W						LED dot current setting for Dot L6-CS15			80h
DC124	17Ch	R/W						LED dot current setting for Dot L6-CS16			80h
DC125	17Dh	R/W						LED dot current setting for Dot L6-CS17			80h

Register Acronym	Address	Type	D7	D6	D5	D4	D3	D2	D1	D0	Default
DC126	17Eh	R/W	LED dot current setting for Dot L7-CS0								80h
DC127	17Fh	R/W	LED dot current setting for Dot L7-CS1								80h
DC128	180h	R/W	LED dot current setting for Dot L7-CS2								80h
DC129	181h	R/W	LED dot current setting for Dot L7-CS3								80h
DC130	182h	R/W	LED dot current setting for Dot L7-CS4								80h
DC131	183h	R/W	LED dot current setting for Dot L7-CS5								80h
DC132	184h	R/W	LED dot current setting for Dot L7-CS6								80h
DC133	185h	R/W	LED dot current setting for Dot L7-CS7								80h
DC134	186h	R/W	LED dot current setting for Dot L7-CS8								80h
DC135	187h	R/W	LED dot current setting for Dot L7-CS9								80h
DC136	188h	R/W	LED dot current setting for Dot L7-CS10								80h
DC137	189h	R/W	LED dot current setting for Dot L7-CS11								80h
DC138	18Ah	R/W	LED dot current setting for Dot L7-CS12								80h
DC139	18Bh	R/W	LED dot current setting for Dot L7-CS13								80h
DC140	18Ch	R/W	LED dot current setting for Dot L7-CS14								80h
DC141	18Dh	R/W	LED dot current setting for Dot L7-CS15								80h
DC142	18Eh	R/W	LED dot current setting for Dot L7-CS16								80h
DC143	18Fh	R/W	LED dot current setting for Dot L7-CS17								80h
pwm_bri0	200h	R/W	8-bits PWM for Dot L0-CS0 OR 16-bits PWM lower 8 bits [7:0] for Dot L0-CS0								00h
pwm_bri1	201h	R/W	8-bits PWM for Dot L0-CS1 OR 16-bits PWM higher 8 bits [15:8] for Dot L0-CS0								00h
pwm_bri2	202h	R/W	8-bits PWM for Dot L0-CS2 OR 16-bits PWM lower 8 bits [7:0] for Dot L0-CS1								00h
pwm_bri3	203h	R/W	8-bits PWM for Dot L0-CS3 OR 16-bits PWM higher 8 bits [15:8] for Dot L0-CS1								00h
pwm_bri4	204h	R/W	8-bits PWM for Dot L0-CS4 OR 16-bits PWM lower 8 bits [7:0] for Dot L0-CS2								00h
pwm_bri5	205h	R/W	8-bits PWM for Dot L0-CS5 OR 16-bits PWM higher 8 bits [15:8] for Dot L0-CS2								00h
pwm_bri6	206h	R/W	8-bits PWM for Dot L0-CS6 OR 16-bits PWM lower 8 bits [7:0] for Dot L0-CS3								00h
pwm_bri7	207h	R/W	8-bits PWM for Dot L0-CS7 OR 16-bits PWM higher 8 bits [15:8] for Dot L0-CS3								00h
pwm_bri8	208h	R/W	8-bits PWM for Dot L0-CS8 OR 16-bits PWM lower 8 bits [7:0] for Dot L0-CS4								00h
pwm_bri9	209h	R/W	8-bits PWM for Dot L0-CS9 OR 16-bits PWM higher 8 bits [15:8] for Dot L0-CS4								00h
pwm_bri10	20Ah	R/W	8-bits PWM for Dot L0-CS10 OR 16-bits PWM lower 8 bits [7:0] for Dot L0-CS5								00h
pwm_bri11	20Bh	R/W	8-bits PWM for Dot L0-CS11 OR 16-bits PWM higher 8 bits [15:8] for Dot L0-CS5								00h
pwm_bri12	20Ch	R/W	8-bits PWM for Dot L0-CS12 OR 16-bits PWM lower 8 bits [7:0] for Dot L0-CS6								00h
pwm_bri13	20Dh	R/W	8-bits PWM for Dot L0-CS13 OR 16-bits PWM higher 8 bits [15:8] for Dot L0-CS6								00h
pwm_bri14	20Eh	R/W	8-bits PWM for Dot L0-CS14 OR 16-bits PWM lower 8 bits [7:0] for Dot L0-CS7								00h
pwm_bri15	20Fh	R/W	8-bits PWM for Dot L0-CS15 OR 16-bits PWM higher 8 bits [15:8] for Dot L0-CS7								00h
pwm_bri16	210h	R/W	8-bits PWM for Dot L0-CS16 OR 16-bits PWM lower 8 bits [7:0] for Dot L0-CS8								00h
pwm_bri17	211h	R/W	8-bits PWM for Dot L0-CS17 OR 16-bits PWM higher 8 bits [15:8] for Dot L0-CS8								00h
pwm_bri18	212h	R/W	8-bits PWM for Dot L1-CS0 OR 16-bits PWM lower 8 bits [7:0] for Dot L0-CS9								00h
pwm_bri19	213h	R/W	8-bits PWM for Dot L1-CS1 OR 16-bits PWM higher 8 bits [15:8] for Dot L0-CS9								00h
pwm_bri20	214h	R/W	8-bits PWM for Dot L1-CS2 OR 16-bits PWM lower 8 bits [7:0] for Dot L0-CS10								00h
pwm_bri21	215h	R/W	8-bits PWM for Dot L1-CS3 OR 16-bits PWM higher 8 bits [15:8] for Dot L0-CS10								00h
pwm_bri22	216h	R/W	8-bits PWM for Dot L1-CS4 OR 16-bits PWM lower 8 bits [7:0] for Dot L0-CS11								00h
pwm_bri23	217h	R/W	8-bits PWM for Dot L1-CS5 OR 16-bits PWM higher 8 bits [15:8] for Dot L0-CS11								00h
pwm_bri24	218h	R/W	8-bits PWM for Dot L1-CS6 OR 16-bits PWM lower 8 bits [7:0] for Dot L0-CS12								00h
pwm_bri25	219h	R/W	8-bits PWM for Dot L1-CS7 OR 16-bits PWM higher 8 bits [15:8] for Dot L0-CS12								00h
pwm_bri26	21Ah	R/W	8-bits PWM for Dot L1-CS8 OR 16-bits PWM lower 8 bits [7:0] for Dot L0-CS13								00h

Register Acronym	Address	Type	D7	D6	D5	D4	D3	D2	D1	D0	Default
pwm_bri27	21Bh	R/W	8-bits PWM for Dot L1-CS9 OR 16-bits PWM higher 8 bits [15:8] for Dot L0-CS13								00h
pwm_bri28	21Ch	R/W	8-bits PWM for Dot L1-CS10 OR 16-bits PWM lower 8 bits [7:0] for Dot L0-CS14								00h
pwm_bri29	21Dh	R/W	8-bits PWM for Dot L1-CS11 OR 16-bits PWM higher 8 bits [15:8] for Dot L0-CS14								00h
pwm_bri30	21Eh	R/W	8-bits PWM for Dot L1-CS12 OR 16-bits PWM lower 8 bits [7:0] for Dot L0-CS15								00h
pwm_bri31	21Fh	R/W	8-bits PWM for Dot L1-CS13 OR 16-bits PWM higher 8 bits [15:8] for Dot L0-CS15								00h
pwm_bri32	220h	R/W	8-bits PWM for Dot L1-CS14 OR 16-bits PWM lower 8 bits [7:0] for Dot L0-CS16								00h
pwm_bri33	221h	R/W	8-bits PWM for Dot L1-CS15 OR 16-bits PWM higher 8 bits [15:8] for Dot L0-CS16								00h
pwm_bri34	222h	R/W	8-bits PWM for Dot L1-CS16 OR 16-bits PWM lower 8 bits [7:0] for Dot L0-CS17								00h
pwm_bri35	223h	R/W	8-bits PWM for Dot L1-CS17 OR 16-bits PWM higher 8 bits [15:8] for Dot L0-CS17								00h
pwm_bri36	224h	R/W	8-bits PWM for Dot L2-CS0 OR 16-bits PWM lower 8 bits [7:0] for Dot L1-CS0								00h
pwm_bri37	225h	R/W	8-bits PWM for Dot L2-CS1 OR 16-bits PWM higher 8 bits [15:8] for Dot L1-CS0								00h
pwm_bri38	226h	R/W	8-bits PWM for Dot L2-CS2 OR 16-bits PWM lower 8 bits [7:0] for Dot L1-CS1								00h
pwm_bri39	227h	R/W	8-bits PWM for Dot L2-CS3 OR 16-bits PWM higher 8 bits [15:8] for Dot L1-CS1								00h
pwm_bri40	228h	R/W	8-bits PWM for Dot L2-CS4 OR 16-bits PWM lower 8 bits [7:0] for Dot L1-CS2								00h
pwm_bri41	229h	R/W	8-bits PWM for Dot L2-CS5 OR 16-bits PWM higher 8 bits [15:8] for Dot L1-CS2								00h
pwm_bri42	22Ah	R/W	8-bits PWM for Dot L2-CS6 OR 16-bits PWM lower 8 bits [7:0] for Dot L1-CS3								00h
pwm_bri43	22Bh	R/W	8-bits PWM for Dot L2-CS7 OR 16-bits PWM higher 8 bits [15:8] for Dot L1-CS3								00h
pwm_bri44	22Ch	R/W	8-bits PWM for Dot L2-CS8 OR 16-bits PWM lower 8 bits [7:0] for Dot L1-CS4								00h
pwm_bri45	22Dh	R/W	8-bits PWM for Dot L2-CS9 OR 16-bits PWM higher 8 bits [15:8] for Dot L1-CS4								00h
pwm_bri46	22Eh	R/W	8-bits PWM for Dot L2-CS10 OR 16-bits PWM lower 8 bits [7:0] for Dot L1-CS5								00h
pwm_bri47	22Fh	R/W	8-bits PWM for Dot L2-CS11 OR 16-bits PWM higher 8 bits [15:8] for Dot L1-CS5								00h
pwm_bri48	230h	R/W	8-bits PWM for Dot L2-CS12 OR 16-bits PWM lower 8 bits [7:0] for Dot L1-CS6								00h
pwm_bri49	231h	R/W	8-bits PWM for Dot L2-CS13 OR 16-bits PWM higher 8 bits [15:8] for Dot L1-CS6								00h
pwm_bri50	232h	R/W	8-bits PWM for Dot L2-CS14 OR 16-bits PWM lower 8 bits [7:0] for Dot L1-CS7								00h
pwm_bri51	233h	R/W	8-bits PWM for Dot L2-CS15 OR 16-bits PWM higher 8 bits [15:8] for Dot L1-CS7								00h
pwm_bri52	234h	R/W	8-bits PWM for Dot L2-CS16 OR 16-bits PWM lower 8 bits [7:0] for Dot L1-CS8								00h
pwm_bri53	235h	R/W	8-bits PWM for Dot L2-CS17 OR 16-bits PWM higher 8 bits [15:8] for Dot L1-CS8								00h
pwm_bri54	236h	R/W	8-bits PWM for Dot L3-CS0 OR 16-bits PWM lower 8 bits [7:0] for Dot L1-CS9								00h
pwm_bri55	237h	R/W	8-bits PWM for Dot L3-CS1 OR 16-bits PWM higher 8 bits [15:8] for Dot L1-CS9								00h
pwm_bri56	238h	R/W	8-bits PWM for Dot L3-CS2 OR 16-bits PWM lower 8 bits [7:0] for Dot L1-CS10								00h
pwm_bri57	239h	R/W	8-bits PWM for Dot L3-CS3 OR 16-bits PWM higher 8 bits [15:8] for Dot L1-CS10								00h
pwm_bri58	23Ah	R/W	8-bits PWM for Dot L3-CS4 OR 16-bits PWM lower 8 bits [7:0] for Dot L1-CS11								00h
pwm_bri59	23Bh	R/W	8-bits PWM for Dot L3-CS5 OR 16-bits PWM higher 8 bits [15:8] for Dot L1-CS11								00h
pwm_bri60	23Ch	R/W	8-bits PWM for Dot L3-CS6 OR 16-bits PWM lower 8 bits [7:0] for Dot L1-CS12								00h
pwm_bri61	23Dh	R/W	8-bits PWM for Dot L3-CS7 OR 16-bits PWM higher 8 bits [15:8] for Dot L1-CS12								00h
pwm_bri62	23Eh	R/W	8-bits PWM for Dot L3-CS8 OR 16-bits PWM lower 8 bits [7:0] for Dot L1-CS13								00h
pwm_bri63	23Fh	R/W	8-bits PWM for Dot L3-CS9 OR 16-bits PWM higher 8 bits [15:8] for Dot L1-CS13								00h
pwm_bri64	240h	R/W	8-bits PWM for Dot L3-CS10 OR 16-bits PWM lower 8 bits [7:0] for Dot L1-CS14								00h
pwm_bri65	241h	R/W	8-bits PWM for Dot L3-CS11 OR 16-bits PWM higher 8 bits [15:8] for Dot L1-CS14								00h
pwm_bri66	242h	R/W	8-bits PWM for Dot L3-CS12 OR 16-bits PWM lower 8 bits [7:0] for Dot L1-CS15								00h
pwm_bri67	243h	R/W	8-bits PWM for Dot L3-CS13 OR 16-bits PWM higher 8 bits [15:8] for Dot L1-CS15								00h
pwm_bri68	244h	R/W	8-bits PWM for Dot L3-CS14 OR 16-bits PWM lower 8 bits [7:0] for Dot L1-CS16								00h
pwm_bri69	245h	R/W	8-bits PWM for Dot L3-CS15 OR 16-bits PWM higher 8 bits [15:8] for Dot L1-CS16								00h
pwm_bri70	246h	R/W	8-bits PWM for Dot L3-CS16 OR 16-bits PWM lower 8 bits [7:0] for Dot L1-CS17								00h
pwm_bri71	247h	R/W	8-bits PWM for Dot L3-CS17 OR 16-bits PWM higher 8 bits [15:8] for Dot L1-CS17								00h

Register Acronym	Address	Type	D7	D6	D5	D4	D3	D2	D1	D0	Default
pwm_bri72	248h	R/W	8-bits PWM for Dot L4-CS0 OR 16-bits PWM lower 8 bits [7:0] for Dot L2-CS0								00h
pwm_bri73	249h	R/W	8-bits PWM for Dot L4-CS1 OR 16-bits PWM higher 8 bits [15:8] for Dot L2-CS0								00h
pwm_bri74	24Ah	R/W	8-bits PWM for Dot L4-CS2 OR 16-bits PWM lower 8 bits [7:0] for Dot L2-CS1								00h
pwm_bri75	24Bh	R/W	8-bits PWM for Dot L4-CS3 OR 16-bits PWM higher 8 bits [15:8] for Dot L2-CS1								00h
pwm_bri76	24Ch	R/W	8-bits PWM for Dot L4-CS4 OR 16-bits PWM lower 8 bits [7:0] for Dot L2-CS2								00h
pwm_bri77	24Dh	R/W	8-bits PWM for Dot L4-CS5 OR 16-bits PWM higher 8 bits [15:8] for Dot L2-CS2								00h
pwm_bri78	24Eh	R/W	8-bits PWM for Dot L4-CS6 OR 16-bits PWM lower 8 bits [7:0] for Dot L2-CS3								00h
pwm_bri79	24Fh	R/W	8-bits PWM for Dot L4-CS7 OR 16-bits PWM higher 8 bits [15:8] for Dot L2-CS3								00h
pwm_bri80	250h	R/W	8-bits PWM for Dot L4-CS8 OR 16-bits PWM lower 8 bits [7:0] for Dot L2-CS4								00h
pwm_bri81	251h	R/W	8-bits PWM for Dot L4-CS9 OR 16-bits PWM higher 8 bits [15:8] for Dot L2-CS4								00h
pwm_bri82	252h	R/W	8-bits PWM for Dot L4-CS10 OR 16-bits PWM lower 8 bits [7:0] for Dot L2-CS5								00h
pwm_bri83	253h	R/W	8-bits PWM for Dot L4-CS11 OR 16-bits PWM higher 8 bits [15:8] for Dot L2-CS5								00h
pwm_bri84	254h	R/W	8-bits PWM for Dot L4-CS12 OR 16-bits PWM lower 8 bits [7:0] for Dot L2-CS6								00h
pwm_bri85	255h	R/W	8-bits PWM for Dot L4-CS13 OR 16-bits PWM higher 8 bits [15:8] for Dot L2-CS6								00h
pwm_bri86	256h	R/W	8-bits PWM for Dot L4-CS14 OR 16-bits PWM lower 8 bits [7:0] for Dot L2-CS7								00h
pwm_bri87	257h	R/W	8-bits PWM for Dot L4-CS15 OR 16-bits PWM higher 8 bits [15:8] for Dot L2-CS7								00h
pwm_bri88	258h	R/W	8-bits PWM for Dot L4-CS16 OR 16-bits PWM lower 8 bits [7:0] for Dot L2-CS8								00h
pwm_bri89	259h	R/W	8-bits PWM for Dot L4-CS17 OR 16-bits PWM higher 8 bits [15:8] for Dot L2-CS8								00h
pwm_bri90	25Ah	R/W	8-bits PWM for Dot L5-CS0 OR 16-bits PWM lower 8 bits [7:0] for Dot L2-CS9								00h
pwm_bri91	25Bh	R/W	8-bits PWM for Dot L5-CS1 OR 16-bits PWM higher 8 bits [15:8] for Dot L2-CS9								00h
pwm_bri92	25Ch	R/W	8-bits PWM for Dot L5-CS2 OR 16-bits PWM lower 8 bits [7:0] for Dot L2-CS10								00h
pwm_bri93	25Dh	R/W	8-bits PWM for Dot L5-CS3 OR 16-bits PWM higher 8 bits [15:8] for Dot L2-CS10								00h
pwm_bri94	25Eh	R/W	8-bits PWM for Dot L5-CS4 OR 16-bits PWM lower 8 bits [7:0] for Dot L2-CS11								00h
pwm_bri95	25Fh	R/W	8-bits PWM for Dot L5-CS5 OR 16-bits PWM higher 8 bits [15:8] for Dot L2-CS11								00h
pwm_bri96	260h	R/W	8-bits PWM for Dot L5-CS6 OR 16-bits PWM lower 8 bits [7:0] for Dot L2-CS12								00h
pwm_bri97	261h	R/W	8-bits PWM for Dot L5-CS7 OR 16-bits PWM higher 8 bits [15:8] for Dot L2-CS12								00h
pwm_bri98	262h	R/W	8-bits PWM for Dot L5-CS8 OR 16-bits PWM lower 8 bits [7:0] for Dot L2-CS13								00h
pwm_bri99	263h	R/W	8-bits PWM for Dot L5-CS9 OR 16-bits PWM higher 8 bits [15:8] for Dot L2-CS13								00h
pwm_bri100	264h	R/W	8-bits PWM for Dot L5-CS10 OR 16-bits PWM lower 8 bits [7:0] for Dot L2-CS14								00h
pwm_bri101	265h	R/W	8-bits PWM for Dot L5-CS11 OR 16-bits PWM higher 8 bits [15:8] for Dot L2-CS14								00h
pwm_bri102	266h	R/W	8-bits PWM for Dot L5-CS12 OR 16-bits PWM lower 8 bits [7:0] for Dot L2-CS15								00h
pwm_bri103	267h	R/W	8-bits PWM for Dot L5-CS13 OR 16-bits PWM higher 8 bits [15:8] for Dot L2-CS15								00h
pwm_bri104	268h	R/W	8-bits PWM for Dot L5-CS14 OR 16-bits PWM lower 8 bits [7:0] for Dot L2-CS16								00h
pwm_bri105	269h	R/W	8-bits PWM for Dot L5-CS15 OR 16-bits PWM higher 8 bits [15:8] for Dot L2-CS16								00h
pwm_bri106	26Ah	R/W	8-bits PWM for Dot L5-CS16 OR 16-bits PWM lower 8 bits [7:0] for Dot L2-CS17								00h
pwm_bri107	26Bh	R/W	8-bits PWM for Dot L5-CS17 OR 16-bits PWM higher 8 bits [15:8] for Dot L2-CS17								00h
pwm_bri108	26Ch	R/W	8-bits PWM for Dot L6-CS0 OR 16-bits PWM lower 8 bits [7:0] for Dot L3-CS0								00h
pwm_bri109	26Dh	R/W	8-bits PWM for Dot L6-CS1 OR 16-bits PWM higher 8 bits [15:8] for Dot L3-CS0								00h
pwm_bri110	26Eh	R/W	8-bits PWM for Dot L6-CS2 OR 16-bits PWM lower 8 bits [7:0] for Dot L3-CS1								00h
pwm_bri111	26Fh	R/W	8-bits PWM for Dot L6-CS3 OR 16-bits PWM higher 8 bits [15:8] for Dot L3-CS1								00h
pwm_bri112	270h	R/W	8-bits PWM for Dot L6-CS4 OR 16-bits PWM lower 8 bits [7:0] for Dot L3-CS2								00h
pwm_bri113	271h	R/W	8-bits PWM for Dot L6-CS5 OR 16-bits PWM higher 8 bits [15:8] for Dot L3-CS2								00h
pwm_bri114	272h	R/W	8-bits PWM for Dot L6-CS6 OR 16-bits PWM lower 8 bits [7:0] for Dot L3-CS3								00h
pwm_bri115	273h	R/W	8-bits PWM for Dot L6-CS7 OR 16-bits PWM higher 8 bits [15:8] for Dot L3-CS3								00h
pwm_bri116	274h	R/W	8-bits PWM for Dot L6-CS8 OR 16-bits PWM lower 8 bits [7:0] for Dot L3-CS4								00h

Register Acronym	Address	Type	D7	D6	D5	D4	D3	D2	D1	D0	Default
pwm_bri117	275h	R/W	8-bits PWM for Dot L6-CS9 OR 16-bits PWM higher 8 bits [15:8] for Dot L3-CS4								00h
pwm_bri118	276h	R/W	8-bits PWM for Dot L6-CS10 OR 16-bits PWM lower 8 bits [7:0] for Dot L3-CS5								00h
pwm_bri119	277h	R/W	8-bits PWM for Dot L6-CS11 OR 16-bits PWM higher 8 bits [15:8] for Dot L3-CS5								00h
pwm_bri120	278h	R/W	8-bits PWM for Dot L6-CS12 OR 16-bits PWM lower 8 bits [7:0] for Dot L3-CS6								00h
pwm_bri121	279h	R/W	8-bits PWM for Dot L6-CS13 OR 16-bits PWM higher 8 bits [15:8] for Dot L3-CS6								00h
pwm_bri122	27Ah	R/W	8-bits PWM for Dot L6-CS14 OR 16-bits PWM lower 8 bits [7:0] for Dot L3-CS7								00h
pwm_bri123	27Bh	R/W	8-bits PWM for Dot L6-CS15 OR 16-bits PWM higher 8 bits [15:8] for Dot L3-CS7								00h
pwm_bri124	27Ch	R/W	8-bits PWM for Dot L6-CS16 OR 16-bits PWM lower 8 bits [7:0] for Dot L3-CS8								00h
pwm_bri125	27Dh	R/W	8-bits PWM for Dot L6-CS17 OR 16-bits PWM higher 8 bits [15:8] for Dot L3-CS8								00h
pwm_bri126	27Eh	R/W	8-bits PWM for Dot L7-CS0 OR 16-bits PWM lower 8 bits [7:0] for Dot L3-CS9								00h
pwm_bri127	27Fh	R/W	8-bits PWM for Dot L7-CS1 OR 16-bits PWM higher 8 bits [15:8] for Dot L3-CS9								00h
pwm_bri128	280h	R/W	8-bits PWM for Dot L7-CS2 OR 16-bits PWM lower 8 bits [7:0] for Dot L3-CS10								00h
pwm_bri129	281h	R/W	8-bits PWM for Dot L7-CS3 OR 16-bits PWM higher 8 bits [15:8] for Dot L3-CS10								00h
pwm_bri130	282h	R/W	8-bits PWM for Dot L7-CS4 OR 16-bits PWM lower 8 bits [7:0] for Dot L3-CS11								00h
pwm_bri131	283h	R/W	8-bits PWM for Dot L7-CS5 OR 16-bits PWM higher 8 bits [15:8] for Dot L3-CS11								00h
pwm_bri132	284h	R/W	8-bits PWM for Dot L7-CS6 OR 16-bits PWM lower 8 bits [7:0] for Dot L3-CS12								00h
pwm_bri133	285h	R/W	8-bits PWM for Dot L7-CS7 OR 16-bits PWM higher 8 bits [15:8] for Dot L3-CS12								00h
pwm_bri134	286h	R/W	8-bits PWM for Dot L7-CS8 OR 16-bits PWM lower 8 bits [7:0] for Dot L3-CS13								00h
pwm_bri135	287h	R/W	8-bits PWM for Dot L7-CS9 OR 16-bits PWM higher 8 bits [15:8] for Dot L3-CS13								00h
pwm_bri136	288h	R/W	8-bits PWM for Dot L7-CS10 OR 16-bits PWM lower 8 bits [7:0] for Dot L3-CS14								00h
pwm_bri137	289h	R/W	8-bits PWM for Dot L7-CS11 OR 16-bits PWM higher 8 bits [15:8] for Dot L3-CS14								00h
pwm_bri138	28Ah	R/W	8-bits PWM for Dot L7-CS12 OR 16-bits PWM lower 8 bits [7:0] for Dot L3-CS15								00h
pwm_bri139	28Bh	R/W	8-bits PWM for Dot L7-CS13 OR 16-bits PWM higher 8 bits [15:8] for Dot L3-CS15								00h
pwm_bri140	28Ch	R/W	8-bits PWM for Dot L7-CS14 OR 16-bits PWM lower 8 bits [7:0] for Dot L3-CS16								00h
pwm_bri141	28Dh	R/W	8-bits PWM for Dot L7-CS15 OR 16-bits PWM higher 8 bits [15:8] for Dot L3-CS16								00h
pwm_bri142	28Eh	R/W	8-bits PWM for Dot L7-CS16 OR 16-bits PWM lower 8 bits [7:0] for Dot L3-CS17								00h
pwm_bri143	28Fh	R/W	8-bits PWM for Dot L7-CS17 OR 16-bits PWM higher 8 bits [15:8] for Dot L3-CS17								00h
pwm_bri144	290h	R/W	16-bits PWM lower 8 bits [7:0] for Dot L4-CS0								00h
pwm_bri145	291h	R/W	16-bits PWM higher 8 bits [15:8] for Dot L4-CS0								00h
pwm_bri146	292h	R/W	16-bits PWM lower 8 bits [7:0] for Dot L4-CS1								00h
pwm_bri147	293h	R/W	16-bits PWM higher 8 bits [15:8] for Dot L4-CS1								00h
pwm_bri148	294h	R/W	16-bits PWM lower 8 bits [7:0] for Dot L4-CS2								00h
pwm_bri149	295h	R/W	16-bits PWM higher 8 bits [15:8] for Dot L4-CS2								00h
pwm_bri150	296h	R/W	16-bits PWM lower 8 bits [7:0] for Dot L4-CS3								00h
pwm_bri151	297h	R/W	16-bits PWM higher 8 bits [15:8] for Dot L4-CS3								00h
pwm_bri152	298h	R/W	16-bits PWM lower 8 bits [7:0] for Dot L4-CS4								00h
pwm_bri153	299h	R/W	16-bits PWM higher 8 bits [15:8] for Dot L4-CS4								00h
pwm_bri154	29Ah	R/W	16-bits PWM lower 8 bits [7:0] for Dot L4-CS5								00h
pwm_bri155	29Bh	R/W	16-bits PWM higher 8 bits [15:8] for Dot L4-CS5								00h
pwm_bri156	29Ch	R/W	16-bits PWM lower 8 bits [7:0] for Dot L4-CS6								00h
pwm_bri157	29Dh	R/W	16-bits PWM higher 8 bits [15:8] for Dot L4-CS6								00h
pwm_bri158	29Eh	R/W	16-bits PWM lower 8 bits [7:0] for Dot L4-CS7								00h
pwm_bri159	29Fh	R/W	16-bits PWM higher 8 bits [15:8] for Dot L4-CS7								00h
pwm_bri160	2A0h	R/W	16-bits PWM lower 8 bits [7:0] for Dot L4-CS8								00h
pwm_bri161	2A1h	R/W	16-bits PWM higher 8 bits [15:8] for Dot L4-CS8								00h

Register Acronym	Address	Type	D7	D6	D5	D4	D3	D2	D1	D0	Default
pwm_bri162	2A2h	R/W	16-bits PWM lower 8 bits [7:0] for Dot L4-CS9								00h
pwm_bri163	2A3h	R/W	16-bits PWM higher 8 bits [15:8] for Dot L4-CS9								00h
pwm_bri164	2A4h	R/W	16-bits PWM lower 8 bits [7:0] for Dot L4-CS10								00h
pwm_bri165	2A5h	R/W	16-bits PWM higher 8 bits [15:8] for Dot L4-CS10								00h
pwm_bri166	2A6h	R/W	16-bits PWM lower 8 bits [7:0] for Dot L4-CS11								00h
pwm_bri167	2A7h	R/W	16-bits PWM higher 8 bits [15:8] for Dot L4-CS11								00h
pwm_bri168	2A8h	R/W	16-bits PWM lower 8 bits [7:0] for Dot L4-CS12								00h
pwm_bri169	2A9h	R/W	16-bits PWM higher 8 bits [15:8] for Dot L4-CS12								00h
pwm_bri170	2AAh	R/W	16-bits PWM lower 8 bits [7:0] for Dot L4-CS13								00h
pwm_bri171	2ABh	R/W	16-bits PWM higher 8 bits [15:8] for Dot L4-CS13								00h
pwm_bri172	2ACh	R/W	16-bits PWM lower 8 bits [7:0] for Dot L4-CS14								00h
pwm_bri173	2ADh	R/W	16-bits PWM higher 8 bits [15:8] for Dot L4-CS14								00h
pwm_bri174	2AEh	R/W	16-bits PWM lower 8 bits [7:0] for Dot L4-CS15								00h
pwm_bri175	2AFh	R/W	16-bits PWM higher 8 bits [15:8] for Dot L4-CS15								00h
pwm_bri176	2B0h	R/W	16-bits PWM lower 8 bits [7:0] for Dot L4-CS16								00h
pwm_bri177	2B1h	R/W	16-bits PWM higher 8 bits [15:8] for Dot L4-CS16								00h
pwm_bri178	2B2h	R/W	16-bits PWM lower 8 bits [7:0] for Dot L4-CS17								00h
pwm_bri179	2B3h	R/W	16-bits PWM higher 8 bits [15:8] for Dot L4-CS17								00h
pwm_bri180	2B4h	R/W	16-bits PWM lower 8 bits [7:0] for Dot L5-CS0								00h
pwm_bri181	2B5h	R/W	16-bits PWM higher 8 bits [15:8] for Dot L5-CS0								00h
pwm_bri182	2B6h	R/W	16-bits PWM lower 8 bits [7:0] for Dot L5-CS1								00h
pwm_bri183	2B7h	R/W	16-bits PWM higher 8 bits [15:8] for Dot L5-CS1								00h
pwm_bri184	2B8h	R/W	16-bits PWM lower 8 bits [7:0] for Dot L5-CS2								00h
pwm_bri185	2B9h	R/W	16-bits PWM higher 8 bits [15:8] for Dot L5-CS2								00h
pwm_bri186	2BAh	R/W	16-bits PWM lower 8 bits [7:0] for Dot L5-CS3								00h
pwm_bri187	2BBh	R/W	16-bits PWM higher 8 bits [15:8] for Dot L5-CS3								00h
pwm_bri188	2BCh	R/W	16-bits PWM lower 8 bits [7:0] for Dot L5-CS4								00h
pwm_bri189	2BDh	R/W	16-bits PWM higher 8 bits [15:8] for Dot L5-CS4								00h
pwm_bri190	2BEh	R/W	16-bits PWM lower 8 bits [7:0] for Dot L5-CS5								00h
pwm_bri191	2BFh	R/W	16-bits PWM higher 8 bits [15:8] for Dot L5-CS5								00h
pwm_bri192	2C0h	R/W	16-bits PWM lower 8 bits [7:0] for Dot L5-CS6								00h
pwm_bri193	2C1h	R/W	16-bits PWM higher 8 bits [15:8] for Dot L5-CS6								00h
pwm_bri194	2C2h	R/W	16-bits PWM lower 8 bits [7:0] for Dot L5-CS7								00h
pwm_bri195	2C3h	R/W	16-bits PWM higher 8 bits [15:8] for Dot L5-CS7								00h
pwm_bri196	2C4h	R/W	16-bits PWM lower 8 bits [7:0] for Dot L5-CS8								00h
pwm_bri197	2C5h	R/W	16-bits PWM higher 8 bits [15:8] for Dot L5-CS8								00h
pwm_bri198	2C6h	R/W	16-bits PWM lower 8 bits [7:0] for Dot L5-CS9								00h
pwm_bri199	2C7h	R/W	16-bits PWM higher 8 bits [15:8] for Dot L5-CS9								00h
pwm_bri200	2C8h	R/W	16-bits PWM lower 8 bits [7:0] for Dot L5-CS10								00h
pwm_bri201	2C9h	R/W	16-bits PWM higher 8 bits [15:8] for Dot L5-CS10								00h
pwm_bri202	2CAh	R/W	16-bits PWM lower 8 bits [7:0] for Dot L5-CS11								00h
pwm_bri203	2CBh	R/W	16-bits PWM higher 8 bits [15:8] for Dot L5-CS11								00h
pwm_bri204	2CCh	R/W	16-bits PWM lower 8 bits [7:0] for Dot L5-CS12								00h
pwm_bri205	2CDh	R/W	16-bits PWM higher 8 bits [15:8] for Dot L5-CS12								00h
pwm_bri206	2CEh	R/W	16-bits PWM lower 8 bits [7:0] for Dot L5-CS13								00h

Register Acronym	Address	Type	D7	D6	D5	D4	D3	D2	D1	D0	Default	
pwm_bri207	2CFh	R/W									16-bits PWM higher 8 bits [15:8] for Dot L5-CS13	00h
pwm_bri208	2D0h	R/W									16-bits PWM lower 8 bits [7:0] for Dot L5-CS14	00h
pwm_bri209	2D1h	R/W									16-bits PWM higher 8 bits [15:8] for Dot L5-CS14	00h
pwm_bri210	2D2h	R/W									16-bits PWM lower 8 bits [7:0] for Dot L5-CS15	00h
pwm_bri211	2D3h	R/W									16-bits PWM higher 8 bits [15:8] for Dot L5-CS15	00h
pwm_bri212	2D4h	R/W									16-bits PWM lower 8 bits [7:0] for Dot L5-CS16	00h
pwm_bri213	2D5h	R/W									16-bits PWM higher 8 bits [15:8] for Dot L5-CS16	00h
pwm_bri214	2D6h	R/W									16-bits PWM lower 8 bits [7:0] for Dot L5-CS17	00h
pwm_bri215	2D7h	R/W									16-bits PWM higher 8 bits [15:8] for Dot L5-CS17	00h
pwm_bri216	2D8h	R/W									16-bits PWM lower 8 bits [7:0] for Dot L6-CS0	00h
pwm_bri217	2D9h	R/W									16-bits PWM higher 8 bits [15:8] for Dot L6-CS0	00h
pwm_bri218	2DAh	R/W									16-bits PWM lower 8 bits [7:0] for Dot L6-CS1	00h
pwm_bri219	2DBh	R/W									16-bits PWM higher 8 bits [15:8] for Dot L6-CS1	00h
pwm_bri220	2DCh	R/W									16-bits PWM lower 8 bits [7:0] for Dot L6-CS2	00h
pwm_bri221	2DDh	R/W									16-bits PWM higher 8 bits [15:8] for Dot L6-CS2	00h
pwm_bri222	2DEh	R/W									16-bits PWM lower 8 bits [7:0] for Dot L6-CS3	00h
pwm_bri223	2DFh	R/W									16-bits PWM higher 8 bits [15:8] for Dot L6-CS3	00h
pwm_bri224	2E0h	R/W									16-bits PWM lower 8 bits [7:0] for Dot L6-CS4	00h
pwm_bri225	2E1h	R/W									16-bits PWM higher 8 bits [15:8] for Dot L6-CS4	00h
pwm_bri226	2E2h	R/W									16-bits PWM lower 8 bits [7:0] for Dot L6-CS5	00h
pwm_bri227	2E3h	R/W									16-bits PWM higher 8 bits [15:8] for Dot L6-CS5	00h
pwm_bri228	2E4h	R/W									16-bits PWM lower 8 bits [7:0] for Dot L6-CS6	00h
pwm_bri229	2E5h	R/W									16-bits PWM higher 8 bits [15:8] for Dot L6-CS6	00h
pwm_bri230	2E6h	R/W									16-bits PWM lower 8 bits [7:0] for Dot L6-CS7	00h
pwm_bri231	2E7h	R/W									16-bits PWM higher 8 bits [15:8] for Dot L6-CS7	00h
pwm_bri232	2E8h	R/W									16-bits PWM lower 8 bits [7:0] for Dot L6-CS8	00h
pwm_bri233	2E9h	R/W									16-bits PWM higher 8 bits [15:8] for Dot L6-CS8	00h
pwm_bri234	2EAh	R/W									16-bits PWM lower 8 bits [7:0] for Dot L6-CS9	00h
pwm_bri235	2EBh	R/W									16-bits PWM higher 8 bits [15:8] for Dot L6-CS9	00h
pwm_bri236	2ECh	R/W									16-bits PWM lower 8 bits [7:0] for Dot L6-CS10	00h
pwm_bri237	2EDh	R/W									16-bits PWM higher 8 bits [15:8] for Dot L6-CS10	00h
pwm_bri238	2EEh	R/W									16-bits PWM lower 8 bits [7:0] for Dot L6-CS11	00h
pwm_bri239	2EFh	R/W									16-bits PWM higher 8 bits [15:8] for Dot L6-CS11	00h
pwm_bri240	2F0h	R/W									16-bits PWM lower 8 bits [7:0] for Dot L6-CS12	00h
pwm_bri241	2F1h	R/W									16-bits PWM higher 8 bits [15:8] for Dot L6-CS12	00h
pwm_bri242	2F2h	R/W									16-bits PWM lower 8 bits [7:0] for Dot L6-CS13	00h
pwm_bri243	2F3h	R/W									16-bits PWM higher 8 bits [15:8] for Dot L6-CS13	00h
pwm_bri244	2F4h	R/W									16-bits PWM lower 8 bits [7:0] for Dot L6-CS14	00h
pwm_bri245	2F5h	R/W									16-bits PWM higher 8 bits [15:8] for Dot L6-CS14	00h
pwm_bri246	2F6h	R/W									16-bits PWM lower 8 bits [7:0] for Dot L6-CS15	00h
pwm_bri247	2F7h	R/W									16-bits PWM higher 8 bits [15:8] for Dot L6-CS15	00h
pwm_bri248	2F8h	R/W									16-bits PWM lower 8 bits [7:0] for Dot L6-CS16	00h
pwm_bri249	2F9h	R/W									16-bits PWM higher 8 bits [15:8] for Dot L6-CS16	00h
pwm_bri250	2FAh	R/W									16-bits PWM lower 8 bits [7:0] for Dot L6-CS17	00h
pwm_bri251	2FBh	R/W									16-bits PWM higher 8 bits [15:8] for Dot L6-CS17	00h

Register Acronym	Address	Type	D7	D6	D5	D4	D3	D2	D1	D0	Default
pwm_bri252	2FCh	R/W	16-bits PWM lower 8 bits [7:0] for Dot L7-CS0								00h
pwm_bri253	2FDh	R/W	16-bits PWM higher 8 bits [15:8] for Dot L7-CS0								00h
pwm_bri254	2FEh	R/W	16-bits PWM lower 8 bits [7:0] for Dot L7-CS1								00h
pwm_bri255	2FFh	R/W	16-bits PWM higher 8 bits [15:8] for Dot L7-CS1								00h
pwm_bri256	300h	R/W	16-bits PWM lower 8 bits [7:0] for Dot L7-CS2								00h
pwm_bri257	301h	R/W	16-bits PWM higher 8 bits [15:8] for Dot L7-CS2								00h
pwm_bri258	302h	R/W	16-bits PWM lower 8 bits [7:0] for Dot L7-CS3								00h
pwm_bri259	303h	R/W	16-bits PWM higher 8 bits [15:8] for Dot L7-CS3								00h
pwm_bri260	304h	R/W	16-bits PWM lower 8 bits [7:0] for Dot L7-CS4								00h
pwm_bri261	305h	R/W	16-bits PWM higher 8 bits [15:8] for Dot L7-CS4								00h
pwm_bri262	306h	R/W	16-bits PWM lower 8 bits [7:0] for Dot L7-CS5								00h
pwm_bri263	307h	R/W	16-bits PWM higher 8 bits [15:8] for Dot L7-CS5								00h
pwm_bri264	308h	R/W	16-bits PWM lower 8 bits [7:0] for Dot L7-CS6								00h
pwm_bri265	309h	R/W	16-bits PWM higher 8 bits [15:8] for Dot L7-CS6								00h
pwm_bri266	30Ah	R/W	16-bits PWM lower 8 bits [7:0] for Dot L7-CS7								00h
pwm_bri267	30Bh	R/W	16-bits PWM higher 8 bits [15:8] for Dot L7-CS7								00h
pwm_bri268	30Ch	R/W	16-bits PWM lower 8 bits [7:0] for Dot L7-CS8								00h
pwm_bri269	30Dh	R/W	16-bits PWM higher 8 bits [15:8] for Dot L7-CS8								00h
pwm_bri270	30Eh	R/W	16-bits PWM lower 8 bits [7:0] for Dot L7-CS9								00h
pwm_bri271	30Fh	R/W	16-bits PWM higher 8 bits [15:8] for Dot L7-CS9								00h
pwm_bri272	310h	R/W	16-bits PWM lower 8 bits [7:0] for Dot L7-CS10								00h
pwm_bri273	311h	R/W	16-bits PWM higher 8 bits [15:8] for Dot L7-CS10								00h
pwm_bri274	312h	R/W	16-bits PWM lower 8 bits [7:0] for Dot L7-CS11								00h
pwm_bri275	313h	R/W	16-bits PWM higher 8 bits [15:8] for Dot L7-CS11								00h
pwm_bri276	314h	R/W	16-bits PWM lower 8 bits [7:0] for Dot L7-CS12								00h
pwm_bri277	315h	R/W	16-bits PWM higher 8 bits [15:8] for Dot L7-CS12								00h
pwm_bri278	316h	R/W	16-bits PWM lower 8 bits [7:0] for Dot L7-CS13								00h
pwm_bri279	317h	R/W	16-bits PWM higher 8 bits [15:8] for Dot L7-CS13								00h
pwm_bri280	318h	R/W	16-bits PWM lower 8 bits [7:0] for Dot L7-CS14								00h
pwm_bri281	319h	R/W	16-bits PWM higher 8 bits [15:8] for Dot L7-CS14								00h
pwm_bri282	31Ah	R/W	16-bits PWM lower 8 bits [7:0] for Dot L7-CS15								00h
pwm_bri283	31Bh	R/W	16-bits PWM higher 8 bits [15:8] for Dot L7-CS15								00h
pwm_bri284	31Ch	R/W	16-bits PWM lower 8 bits [7:0] for Dot L7-CS16								00h
pwm_bri285	31Dh	R/W	16-bits PWM higher 8 bits [15:8] for Dot L7-CS16								00h
pwm_bri286	31Eh	R/W	16-bits PWM lower 8 bits [7:0] for Dot L7-CS17								00h
pwm_bri287	31Fh	R/W	16-bits PWM higher 8 bits [15:8] for Dot L7-CS17								00h

8 Application and Implementation

注

Information in the following applications sections is not part of the TI component specification, and TI does not warrant its accuracy or completeness. TI's customers are responsible for determining suitability of components for their purposes, as well as validating and testing their design implementation to confirm system functionality.

8.1 Application Information

The LP5868T integrates 18 constant current sinks with 8 switching FETs and one LP5868T can drive up to 144 LED dots or 48 RGB pixels and achieve great dimming effect. In smart home, gaming keyboards, and other human-machine interaction applications, the device can greatly improve user experience with small amount of components.

8.2 Typical Application

8.2.1 Application

Figure 8-1 shows an example of typical application, which uses one LP5868T to drive 66 common-anode RGB LEDs through I²C communication.

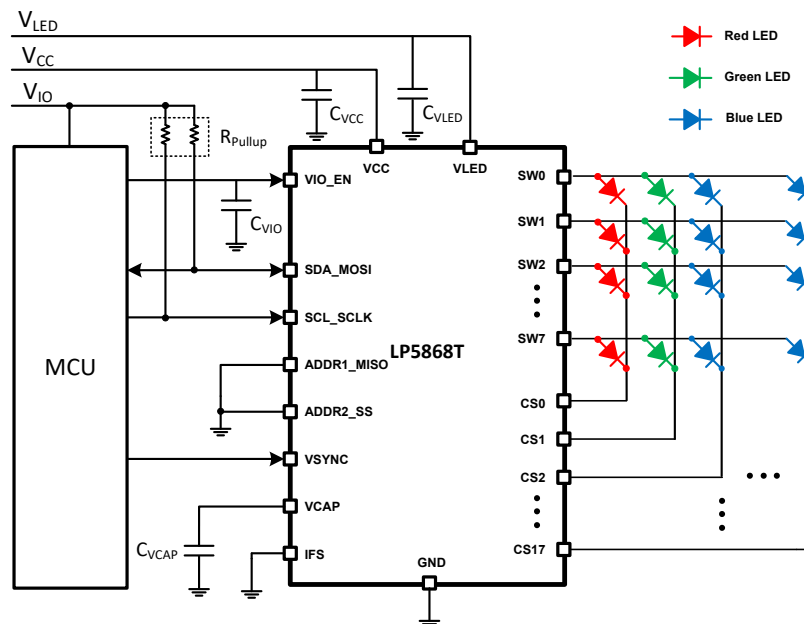

Figure 8-1. Typical Application - LP5868T Driving 48 RGB LEDs (144 LED Dots)

8.2.2 Design Requirements

表 8-1. Design Parameters

PARAMETER	VALUE
VCC / VIO	3.3V
VLED	5V
RGB LED count	48
Scan number	8
Interface	I ² C
LED maximum average current (red, green, blue)	12.5mA, 11.25mA, 10mA
LED maximum peak current (red, green, blue)	100mA, 90mA, 80mA

8.2.3 Detailed Design Procedure

LP5868T requires an external capacitor $C_{V_{CAP}}$, whose value is $1\mu\text{F}$ connected from V_{CAP} to GND for proper operation of internal LDO. The device must be placed as close to the device as possible.

TI recommends that $1\text{-}\mu\text{F}$ capacitors be placed between VCC / VLED with GND, and a 1nF capacitor placed between VIO with GND. Place the capacitors as close to the device as possible.

Pull-up resistors $R_{\text{pull-up}}$ are requirement for SCL and SDA when using I²C as communication method. In typical applications, TI recommends $1.8\text{k}\Omega$ to $4.7\text{k}\Omega$ resistors.

To decrease thermal dissipation from device to ambient, resistors R_{CS} can optionally be placed in serial with the LED. Voltage drop on these resistors must left enough margins for VSAT to ensure the device works normally.

8.2.3.1 Program Procedure

When selecting data refresh Mode 1, outputs are refreshed instantly after data is received.

When selecting data refresh Mode 2/3, VSYNC signal is required for synchronized display. Programming flow is showed as 图 8-2. To display full pixel of last frame, VSYNC pulse must be sent to the device after the end of last PWM. Time between two pulses t_{VSYNC} must be larger than the whole PWM time of all Dots t_{frame} . Common selection like 60Hz, 90Hz, 120Hz or even higher refresh frequency can be supported. High pulse width longer than $t_{\text{VSYNC_H}}$ is required at the beginning of each VSYNC frame, and data must not be write to PWM registers during high pulse width.



图 8-2. Program Procedure

8.2.4 Application Performance Plots

The following figures show the application performance plots.

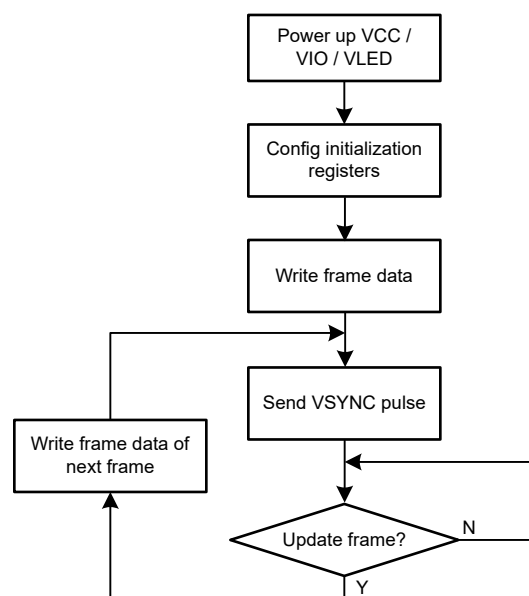
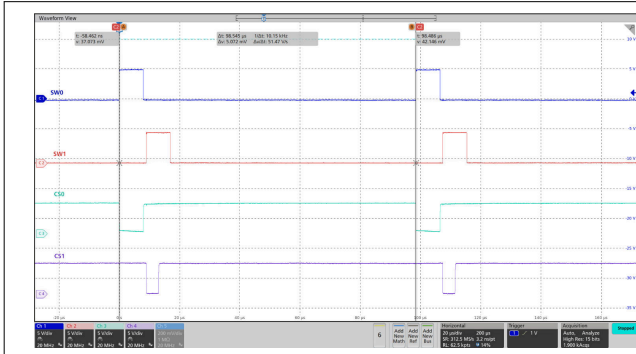

8-3. Scan Lines and Current Sinks Waveforms of SW0, SW1, CS0, CS1

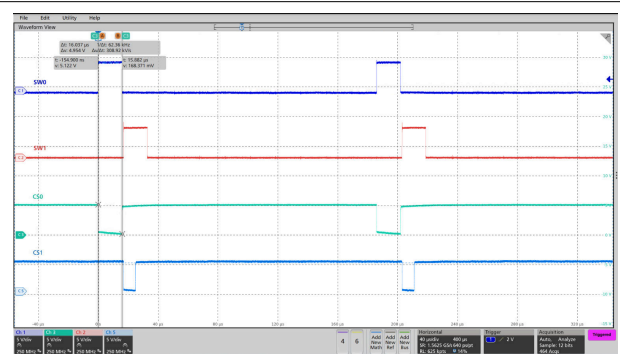

PWM frequency = 62.5kHz

8-4. Scan Lines and Current Sinks Waveforms of SW0, SW1, CS0, CS1

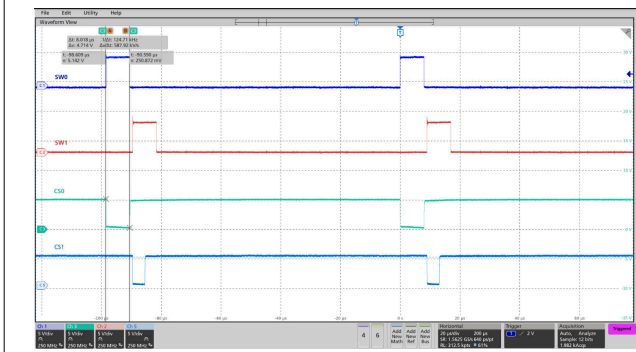

PWM frequency = 125kHz

8-5. Scan Lines and Current Sinks Waveforms of SW0, SW1, CS0, CS1

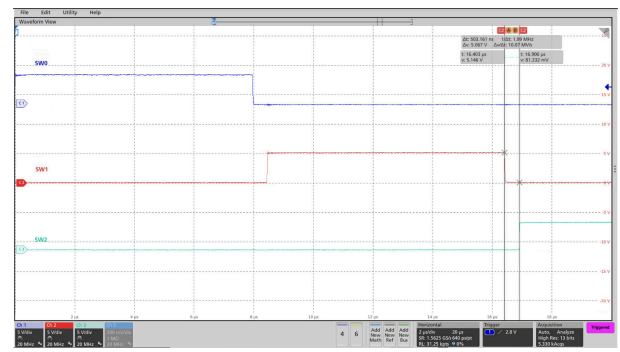

Switch blank time $t_{SW_BLK} = 0.5\mu s$

8-6. Scan Lines Switching Waveforms of SW0, SW1, SW2

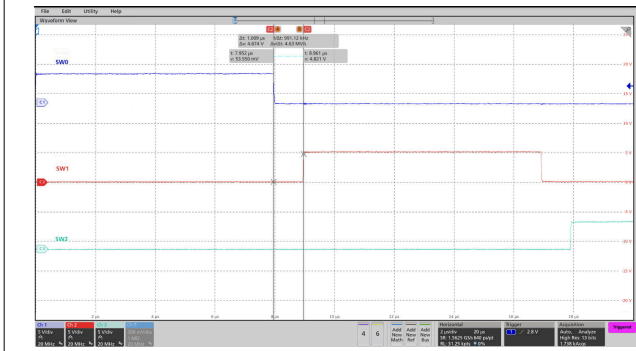

Switch blank time $t_{SW_BLK} = 1\mu s$

8-7. Scan Lines Switching Waveforms of SW0, SW1, SW2

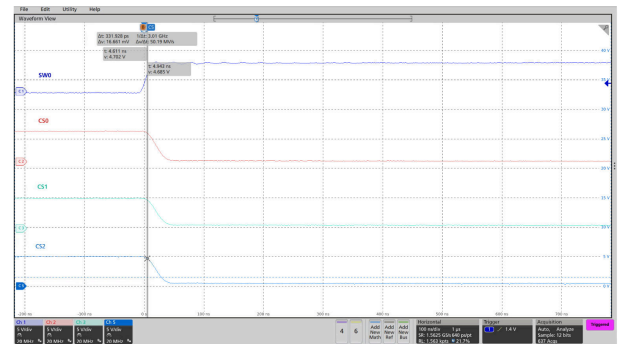

PWM_Phase_Shift = 0h

8-8. PWM Phase Shift Disabled

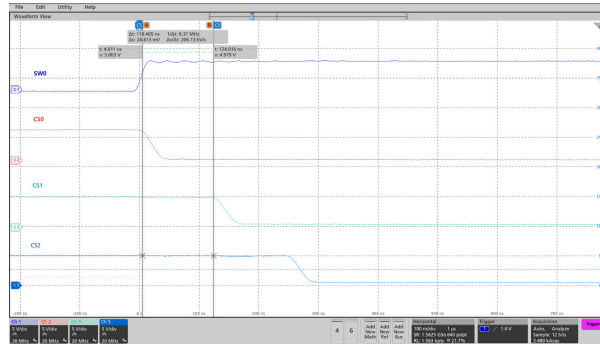

PWM_Phase_Shift = 1h

 8-9. PWM Phase Shift Enabled

8.3 Power Supply Recommendations

8.3.1 VDD Input Supply Recommendations

LP5868T is designed to operate from a 2.7V to 5.5V VDD voltage supply. This input supply must be well regulated and be able to provide the peak current required by the LED matrix. The resistance of the VDD supply rail must be low enough such that the input current transient does not cause the LP5868T VDD supply voltage to drop below the maximum POR voltage.

8.3.2 VLED Input Supply Recommendations

LP5868T is designed to operate with a 2.7V to 5.5V VLED voltage supply. The VLED supply must be well regulated and able to provide the peak current required by the LED configuration without voltage drop, under load transients like start-up or rapid brightness change. The resistance of the input supply rail must be low enough so that the input current transient does not cause the VLED supply voltage to drop below LED $V_f + VSAT$ voltage.

8.3.3 VIO Input Supply Recommendations

LP5868T is designed to operate with a 1.65V to 5.5V VIO_EN voltage supply. The VIO_EN supply must be well regulated and able to provide the peak current required by the LED configuration without voltage drop under load transients like startup or rapid brightness change.

8.4 Layout

8.4.1 Layout Guidelines

Below guidelines for layout design can help to get a better on-board performance.

- The decoupling capacitors C_{VCC} and C_{VLED} for power supply must be close to the chip to have minimized the impact of high-frequency noise and ripple from power. C_{VCAP} for internal LDO must be put as close to chip as possible. GND plane connections to C_{VLED} and GND pins must be on TOP layer copper with multiple vias connecting to system ground plane. C_{VIO} for internal enable block also must be put as close to chip as possible.
- The exposed thermal pad must be well soldered to the board, which can have better mechanical reliability. This action can optimize heat transfer so that increasing thermal performance. The AGND pin must be connected to thermal pad and system ground.
- The major heat flow path from the package to the ambient is through copper on the PCB. Several methods can help thermal performance. Below exposed thermal pad of the device, putting much vias through the PCB to other ground layer can dissipate more heat. Maximizing the copper coverage on the PCB can increase the thermal conductivity of the board.
- Low inductive and resistive path of switch load loop can help to provide a high slew rate. Therefore, path of VLED – SWx must be short and wide and avoid parallel wiring and narrow trace. Transient current in SWx pins is much larger than CSy pins, so that trace for SWx must be wider than CSy.

8.4.2 Layout Example

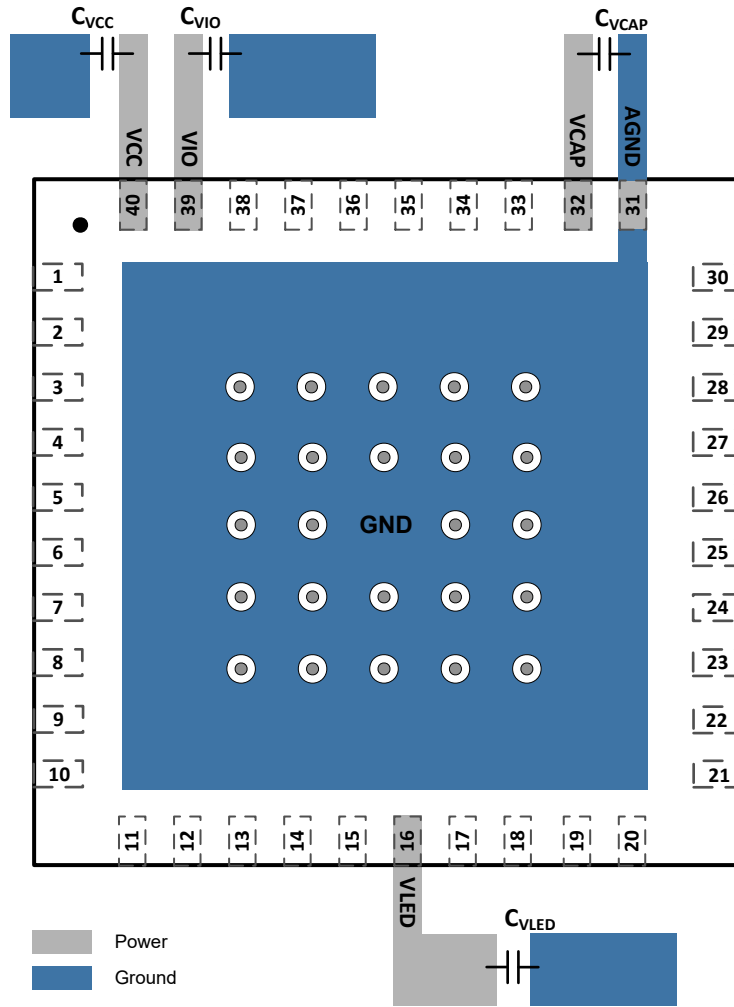

 8-10. LP5868T Layout Example

9 Device and Documentation Support

TI offers an extensive line of development tools. Tools and software to evaluate the performance of the device, generate code, and develop solutions are listed below.

9.1 ドキュメントの更新通知を受け取る方法

ドキュメントの更新についての通知を受け取るには、www.tij.co.jp のデバイス製品フォルダを開いてください。[通知] をクリックして登録すると、変更されたすべての製品情報に関するダイジェストを毎週受け取ることができます。変更の詳細については、改訂されたドキュメントに含まれている改訂履歴をご覧ください。

9.2 サポート・リソース

テキサス・インスツルメンツ E2E™ サポート・フォーラムは、エンジニアが検証済みの回答と設計に関するヒントをエキスパートから迅速かつ直接得ることができる場所です。既存の回答を検索したり、独自の質問をしたりすることで、設計に必要な支援を迅速に得ることができます。

リンクされているコンテンツは、各寄稿者により「現状のまま」提供されるものです。これらはテキサス・インスツルメンツの仕様を構成するものではなく、必ずしもテキサス・インスツルメンツの見解を反映したものではありません。テキサス・インスツルメンツの[使用条件](#)を参照してください。

9.3 Trademarks

テキサス・インスツルメンツ E2E™ is a trademark of Texas Instruments.

すべての商標は、それぞれの所有者に帰属します。

9.4 静電気放電に関する注意事項



この IC は、ESD によって破損する可能性があります。テキサス・インスツルメンツは、IC を取り扱う際には常に適切な注意を払うことを推奨します。正しい取り扱いおよび設置手順に従わない場合、デバイスを破損するおそれがあります。

ESD による破損は、わずかな性能低下からデバイスの完全な故障まで多岐にわたります。精密な IC の場合、パラメータがわずかに変化するだけで公表されている仕様から外れる可能性があるため、破損が発生しやすくなっています。

9.5 用語集

[テキサス・インスツルメンツ用語集](#) この用語集には、用語や略語の一覧および定義が記載されています。

10 Revision History

資料番号末尾の英字は改訂を表しています。その改訂履歴は英語版に準じています。

Changes from Revision A (August 2023) to Revision B (November 2023) Page

- | | |
|---|---|
| • タイトルを 8 ビット アナログおよび 8 または 16 ビット PWM 調光搭載、11 × 18 LED 大電流マトリクスドライブに更新 | 1 |
|---|---|

Changes from Revision * (May 2023) to Revision A (August 2023) Page

- | | |
|----------------------------------|---|
| • ステータスを「事前情報」から「量産データ」に変更 | 1 |
|----------------------------------|---|

11 Mechanical, Packaging, and Orderable Information

The following pages include mechanical, packaging, and orderable information. This information is the most current data available for the designated devices. This data is subject to change without notice and revision of this document. For browser-based versions of this data sheet, refer to the left-hand navigation.

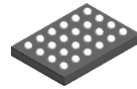

YBH0024-C02

PACKAGE OUTLINE

DSBGA - 0.4 mm max height

DIE SIZE BALL GRID ARRAY

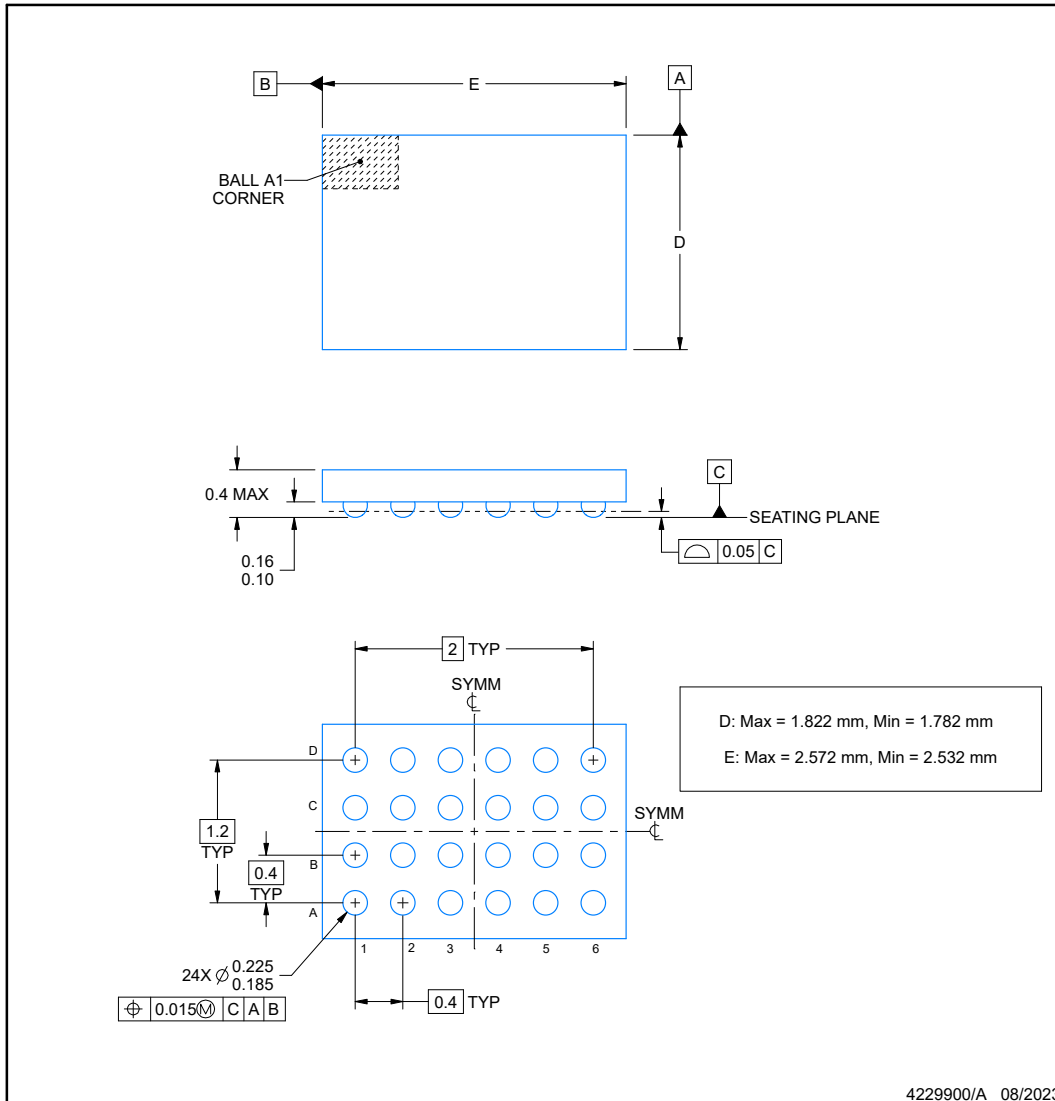

NOTES:

1. All linear dimensions are in millimeters. Any dimensions in parenthesis are for reference only. Dimensioning and tolerancing per ASME Y14.5M.
2. This drawing is subject to change without notice.

EXAMPLE BOARD LAYOUT

YBH0024-C02

DSBGA - 0.4 mm max height

DIE SIZE BALL GRID ARRAY

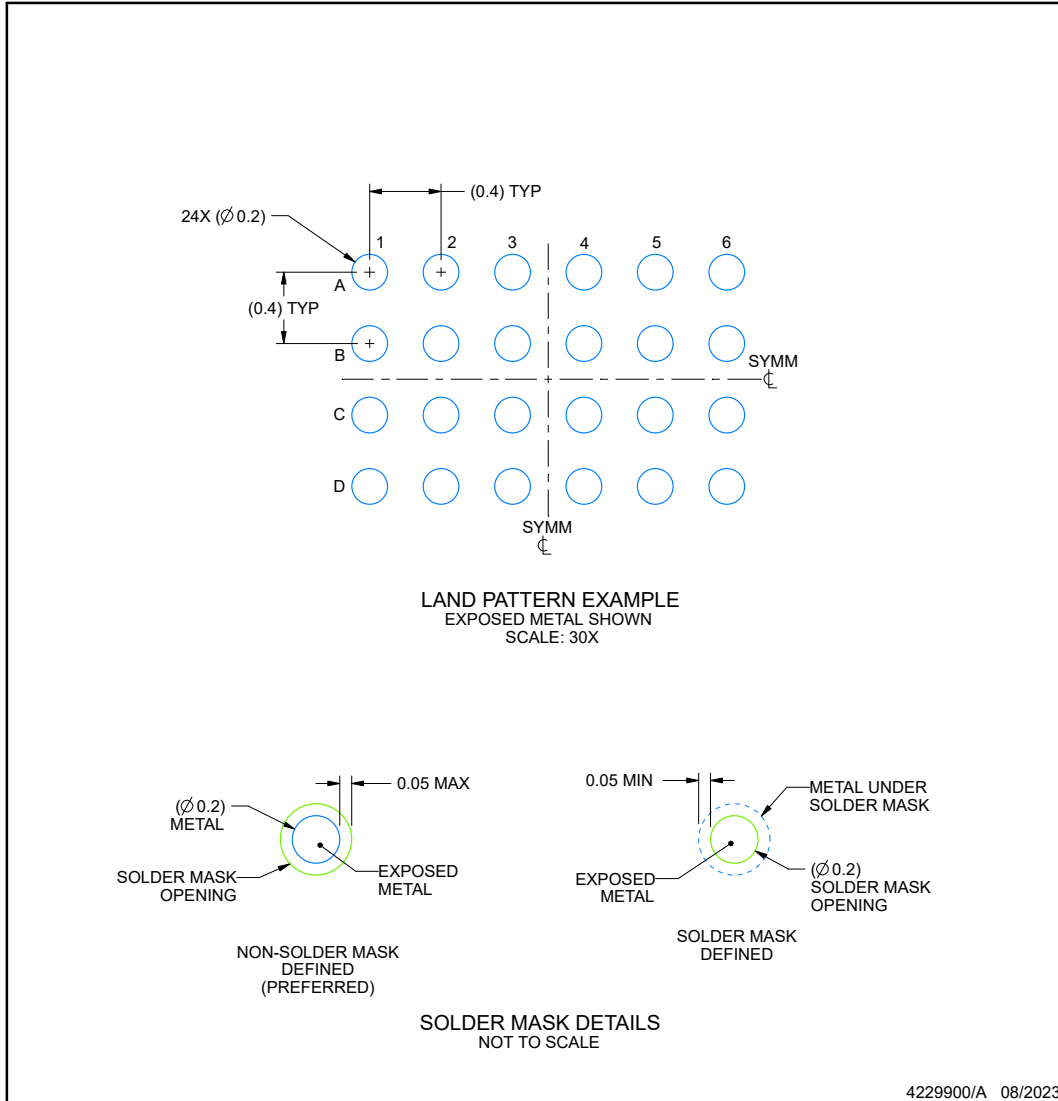

NOTES: (continued)

- Final dimensions may vary due to manufacturing tolerance considerations and also routing constraints. See Texas Instruments Literature No. SNVA009 (www.ti.com/lit/snva009).

EXAMPLE STENCIL DESIGN

YBH0024-C02

DSBGA - 0.4 mm max height

DIE SIZE BALL GRID ARRAY

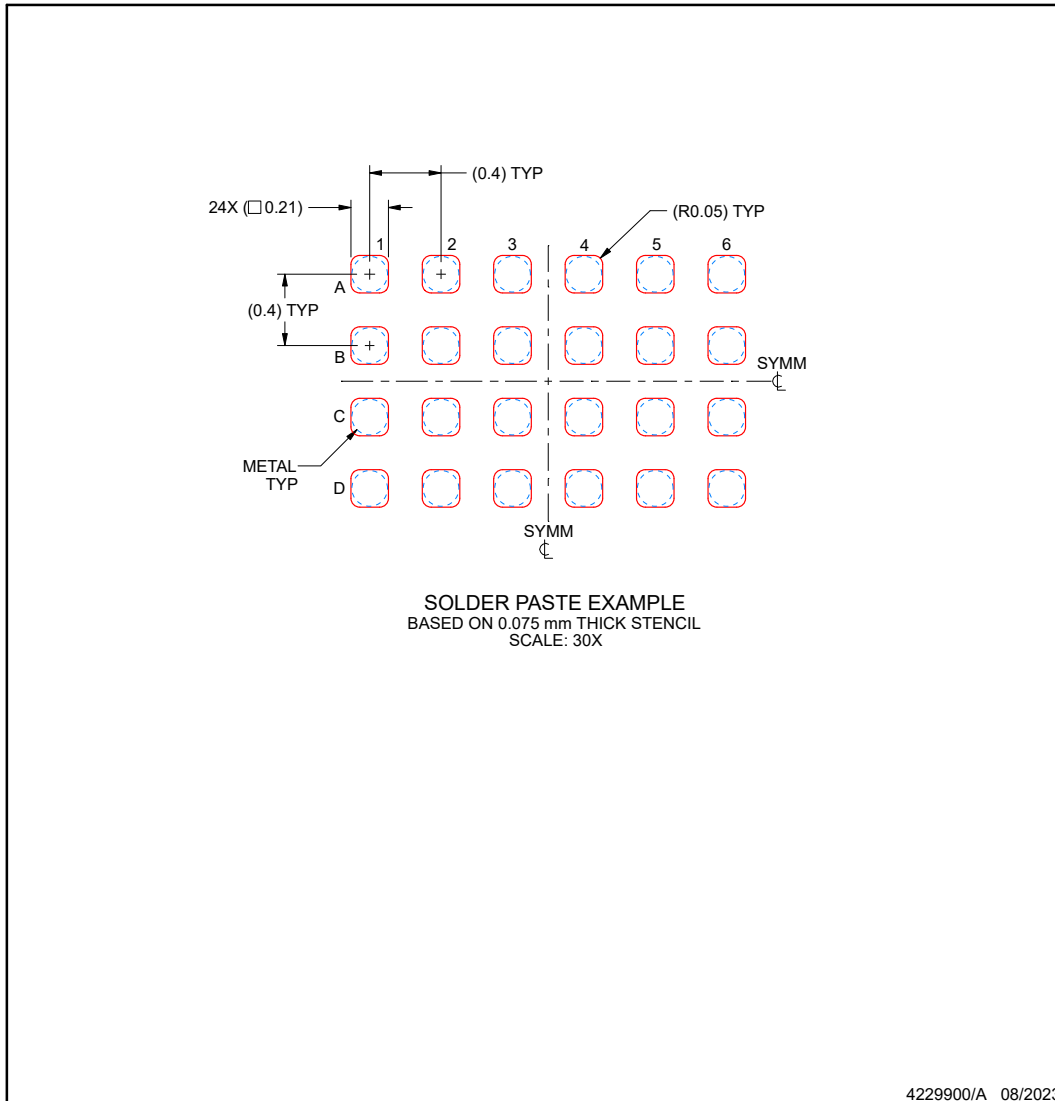

NOTES: (continued)

- 4. Laser cutting apertures with trapezoidal walls and rounded corners may offer better paste release.

重要なお知らせと免責事項

テキサス・インスツルメンツは、技術データと信頼性データ(データシートを含みます)、設計リソース(リファレンス デザインを含みます)、アプリケーションや設計に関する各種アドバイス、Web ツール、安全性情報、その他のリソースを、欠陥が存在する可能性のある「現状のまま」提供しており、商品性および特定目的に対する適合性の黙示保証、第三者の知的財産権の非侵害保証を含むいかなる保証も、明示的または黙示的にかかわらず拒否します。

これらのリソースは、テキサス・インスツルメンツ製品を使用する設計の経験を積んだ開発者への提供を意図したものです。(1) お客様のアプリケーションに適したテキサス・インスツルメンツ製品の選定、(2) お客様のアプリケーションの設計、検証、試験、(3) お客様のアプリケーションに該当する各種規格や、その他のあらゆる安全性、セキュリティ、規制、または他の要件への確実な適合に関する責任を、お客様のみが単独で負うものとします。

上記の各種リソースは、予告なく変更される可能性があります。これらのリソースは、リソースで説明されているテキサス・インスツルメンツ製品を使用するアプリケーションの開発の目的でのみ、テキサス・インスツルメンツはその使用をお客様に許諾します。これらのリソースに関して、他の目的で複製することや掲載することは禁止されています。テキサス・インスツルメンツや第三者の知的財産権のライセンスが付与されている訳ではありません。お客様は、これらのリソースを自身で使用した結果発生するあらゆる申し立て、損害、費用、損失、責任について、テキサス・インスツルメンツおよびその代理人を完全に補償するものとし、テキサス・インスツルメンツは一切の責任を拒否します。

テキサス・インスツルメンツの製品は、[テキサス・インスツルメンツの販売条件](#)、または [ti.com](https://www.ti.com) やかかるテキサス・インスツルメンツ製品の関連資料などのいずれかを通じて提供する適用可能な条項の下で提供されています。テキサス・インスツルメンツがこれらのリソースを提供することは、適用されるテキサス・インスツルメンツの保証または他の保証の放棄の拡大や変更を意味するものではありません。

お客様がいかなる追加条項または代替条項を提案した場合でも、テキサス・インスツルメンツはそれらに異議を唱え、拒否します。

郵送先住所: Texas Instruments, Post Office Box 655303, Dallas, Texas 75265
Copyright © 2024, Texas Instruments Incorporated

PACKAGING INFORMATION

Orderable Device	Status (1)	Package Type	Package Drawing	Pins	Package Qty	Eco Plan (2)	Lead finish/ Ball material (6)	MSL Peak Temp (3)	Op Temp (°C)	Device Marking (4/5)	Samples
LP5868TMRKPR	ACTIVE	VQFN	RKP	40	3000	RoHS & Green	NIPDAU	Level-1-260C-UNLIM	-55 to 125	5868TM	Samples
LP5868TRKPR	ACTIVE	VQFN	RKP	40	3000	RoHS & Green	NIPDAU	Level-2-260C-1 YEAR	-40 to 85	LP5868T	Samples

(1) The marketing status values are defined as follows:

ACTIVE: Product device recommended for new designs.

LIFEBUY: TI has announced that the device will be discontinued, and a lifetime-buy period is in effect.

NRND: Not recommended for new designs. Device is in production to support existing customers, but TI does not recommend using this part in a new design.

PREVIEW: Device has been announced but is not in production. Samples may or may not be available.

OBSELETE: TI has discontinued the production of the device.

(2) **RoHS:** TI defines "RoHS" to mean semiconductor products that are compliant with the current EU RoHS requirements for all 10 RoHS substances, including the requirement that RoHS substance do not exceed 0.1% by weight in homogeneous materials. Where designed to be soldered at high temperatures, "RoHS" products are suitable for use in specified lead-free processes. TI may reference these types of products as "Pb-Free".

RoHS Exempt: TI defines "RoHS Exempt" to mean products that contain lead but are compliant with EU RoHS pursuant to a specific EU RoHS exemption.

Green: TI defines "Green" to mean the content of Chlorine (Cl) and Bromine (Br) based flame retardants meet JS709B low halogen requirements of <=1000ppm threshold. Antimony trioxide based flame retardants must also meet the <=1000ppm threshold requirement.

(3) MSL, Peak Temp. - The Moisture Sensitivity Level rating according to the JEDEC industry standard classifications, and peak solder temperature.

(4) There may be additional marking, which relates to the logo, the lot trace code information, or the environmental category on the device.

(5) Multiple Device Markings will be inside parentheses. Only one Device Marking contained in parentheses and separated by a "~" will appear on a device. If a line is indented then it is a continuation of the previous line and the two combined represent the entire Device Marking for that device.

(6) Lead finish/Ball material - Orderable Devices may have multiple material finish options. Finish options are separated by a vertical ruled line. Lead finish/Ball material values may wrap to two lines if the finish value exceeds the maximum column width.

Important Information and Disclaimer:The information provided on this page represents TI's knowledge and belief as of the date that it is provided. TI bases its knowledge and belief on information provided by third parties, and makes no representation or warranty as to the accuracy of such information. Efforts are underway to better integrate information from third parties. TI has taken and continues to take reasonable steps to provide representative and accurate information but may not have conducted destructive testing or chemical analysis on incoming materials and chemicals. TI and TI suppliers consider certain information to be proprietary, and thus CAS numbers and other limited information may not be available for release.

In no event shall TI's liability arising out of such information exceed the total purchase price of the TI part(s) at issue in this document sold by TI to Customer on an annual basis.

TAPE AND REEL INFORMATION

QUADRANT ASSIGNMENTS FOR PIN 1 ORIENTATION IN TAPE

*All dimensions are nominal

Device	Package Type	Package Drawing	Pins	SPQ	Reel Diameter (mm)	Reel Width W1 (mm)	A0 (mm)	B0 (mm)	K0 (mm)	P1 (mm)	W (mm)	Pin1 Quadrant
LP5868TMRKPR	VQFN	RKP	40	3000	330.0	12.4	5.3	5.3	1.1	8.0	12.0	Q2
LP5868TRKPR	VQFN	RKP	40	3000	330.0	12.4	5.3	5.3	1.1	8.0	12.0	Q2

TAPE AND REEL BOX DIMENSIONS

*All dimensions are nominal

Device	Package Type	Package Drawing	Pins	SPQ	Length (mm)	Width (mm)	Height (mm)
LP5868TMRKPR	VQFN	RKP	40	3000	367.0	367.0	35.0
LP5868TRKPR	VQFN	RKP	40	3000	367.0	367.0	35.0

GENERIC PACKAGE VIEW

RKP 40

VQFN - 1 mm max height

5 x 5, 0.4 mm pitch

PLASTIC QUAD FLATPACK - NO LEAD

This image is a representation of the package family, actual package may vary.
Refer to the product data sheet for package details.

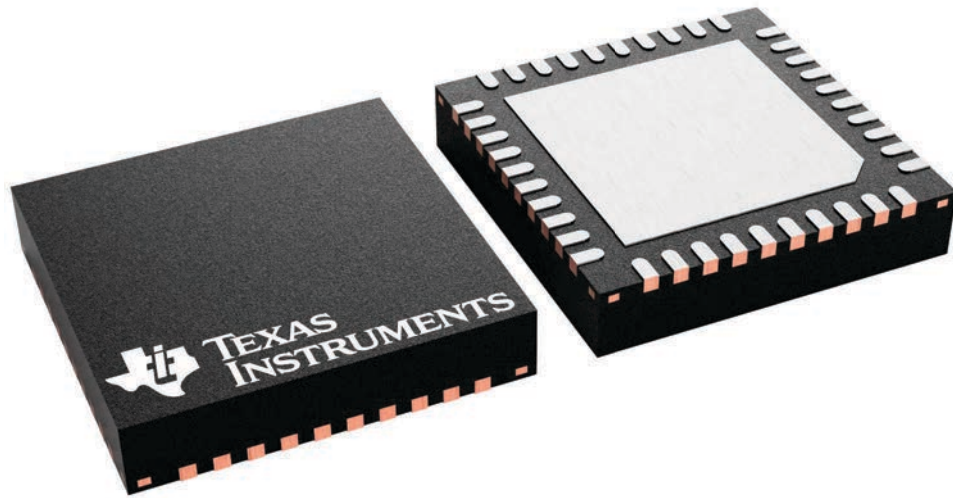

4229305/A

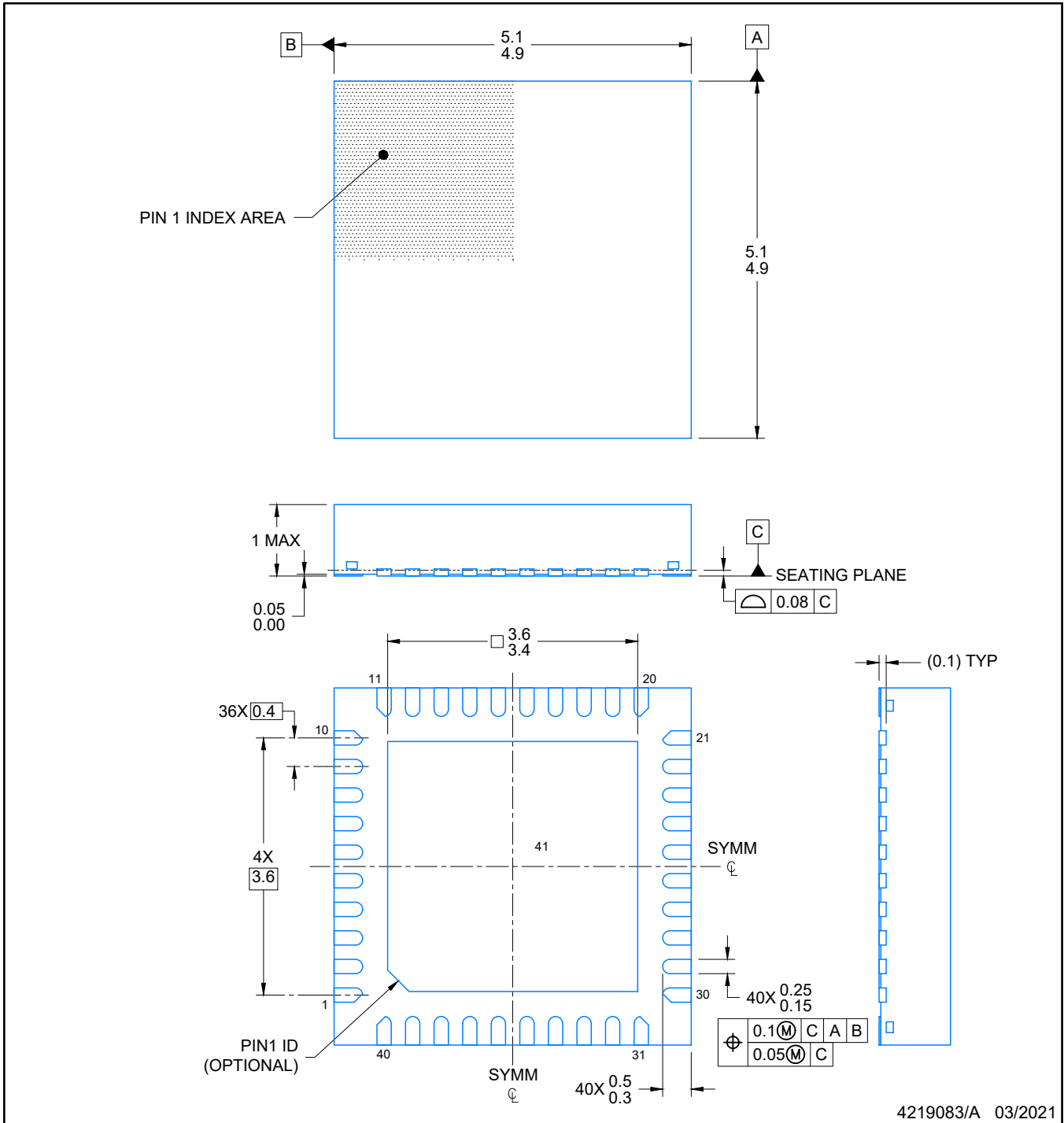

NOTES:

1. All linear dimensions are in millimeters. Any dimensions in parenthesis are for reference only. Dimensioning and tolerancing per ASME Y14.5M.
2. This drawing is subject to change without notice.
3. The package thermal pad must be soldered to the printed circuit board for optimal thermal and mechanical performance.

EXAMPLE BOARD LAYOUT

RKP0040B

VQFN - 1 mm max height

PLASTIC QUAD FLATPACK- NO LEAD

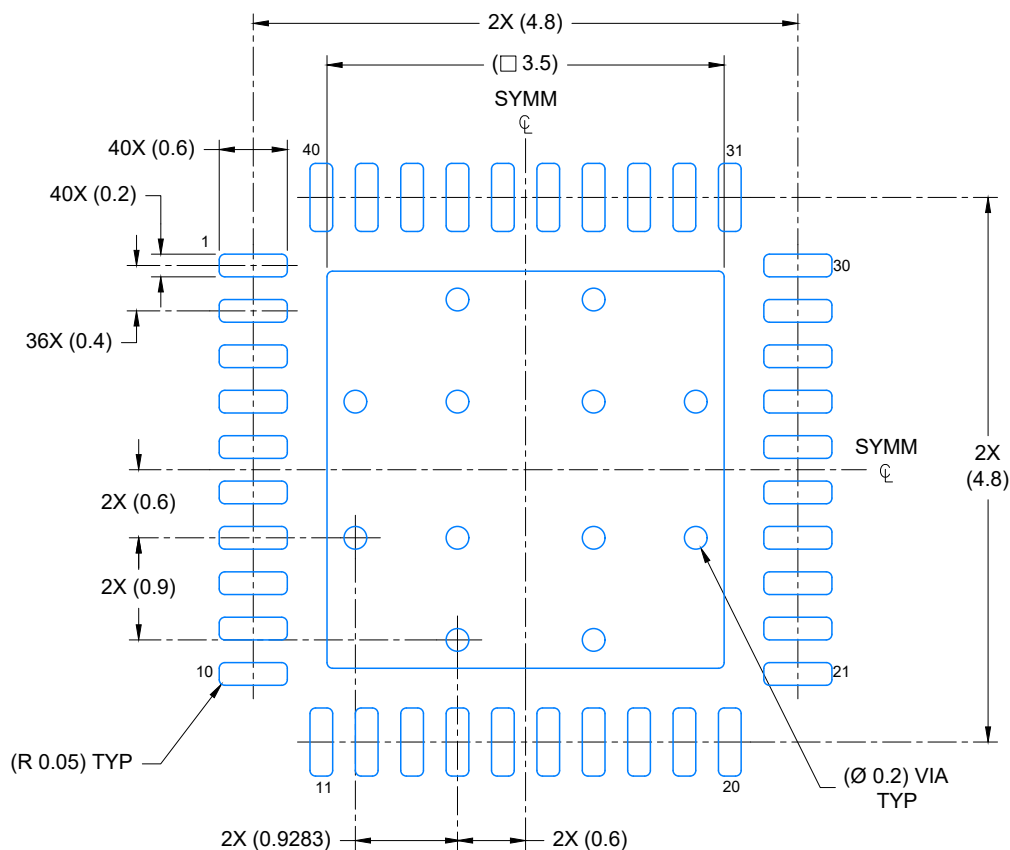

LAND PATTERN EXAMPLE
EXPOSED METAL SHOWN
SCALE: 15X

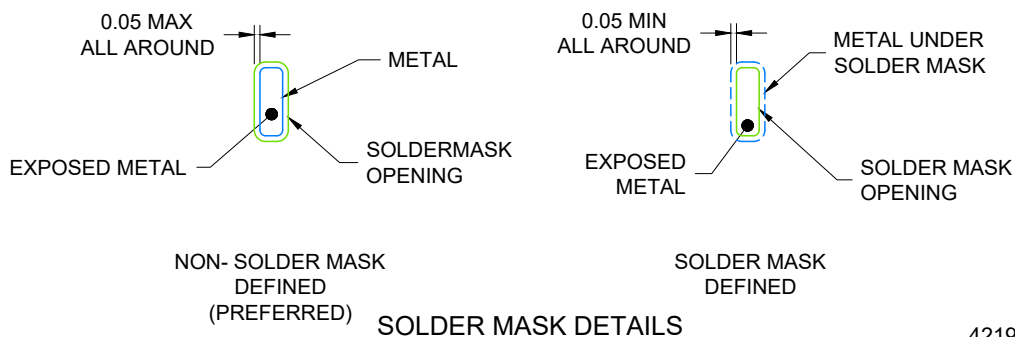

4219083/A 03/2021

NOTES: (continued)

- This package is designed to be soldered to a thermal pad on the board. For more information, see Texas Instruments literature number SLUA271 (www.ti.com/lit/slua271).
- Vias are optional depending on application, refer to device data sheet. If any vias are implemented, refer to their locations shown on this view. It is recommended that vias under paste be filled, plugged or tented.

EXAMPLE STENCIL DESIGN

VQFN - 1 mm max height

RKP0040B

PLASTIC QUAD FLATPACK- NO LEAD

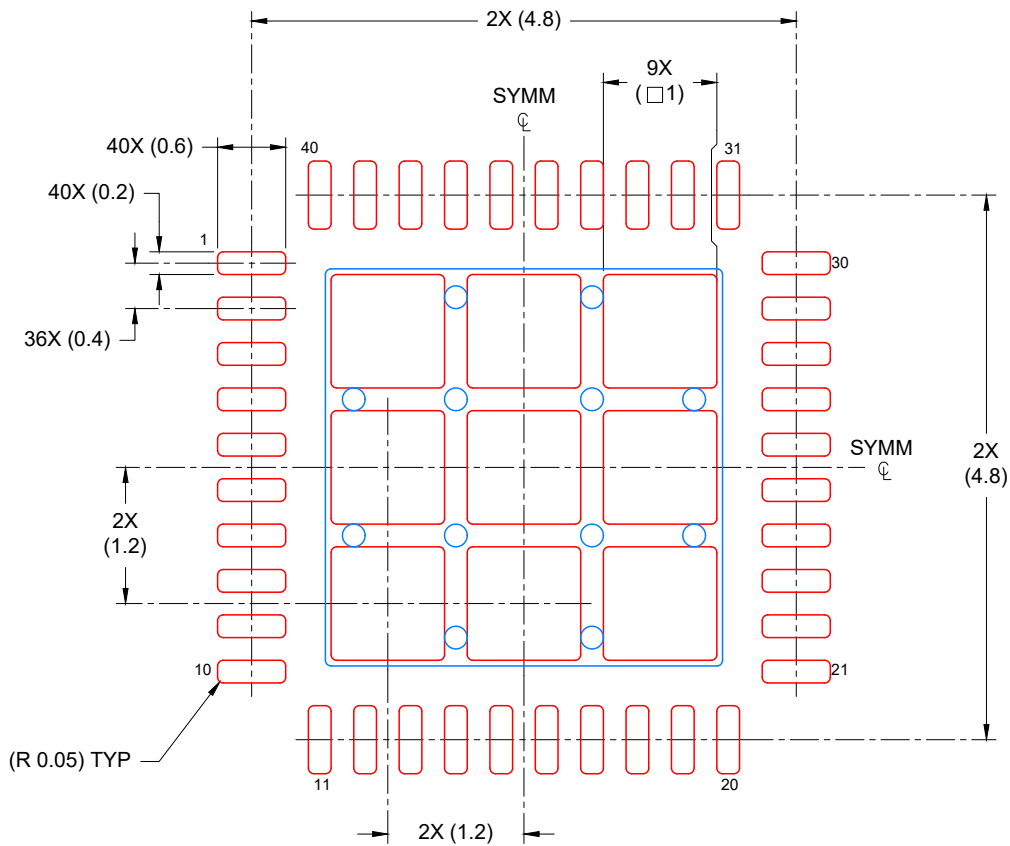

SOLDER PASTE EXAMPLE
BASED ON 0.125 mm THICK STENCIL

EXPOSED PAD
74% PRINTED COVERAGE BY AREA
SCALE: 15X

4219083/A 03/2021

NOTES: (continued)

6. Laser cutting apertures with trapezoidal walls and rounded corners may offer better paste release. IPC-7525 may have alternate design recommendations.

重要なお知らせと免責事項

TI は、技術データと信頼性データ（データシートを含みます）、設計リソース（リファレンス・デザインを含みます）、アプリケーションや設計に関する各種アドバイス、Web ツール、安全性情報、その他のリソースを、欠陥が存在する可能性のある「現状のまま」提供しており、商品性および特定目的に対する適合性の黙示保証、第三者の知的財産権の非侵害保証を含むいかなる保証も、明示的または黙示的にかかわらず拒否します。

これらのリソースは、TI 製品を使用する設計の経験を積んだ開発者への提供を意図したものです。(1) お客様のアプリケーションに適した TI 製品の選定、(2) お客様のアプリケーションの設計、検証、試験、(3) お客様のアプリケーションに該当する各種規格や、その他のあらゆる安全性、セキュリティ、規制、または他の要件への確実な適合に関する責任を、お客様のみが単独で負うものとし、

上記の各種リソースは、予告なく変更される可能性があります。これらのリソースは、リソースで説明されている TI 製品を使用するアプリケーションの開発の目的でのみ、TI はその使用をお客様に許諾します。これらのリソースに関して、他の目的で複製することや掲載することは禁止されています。TI や第三者の知的財産権のライセンスが付与されている訳ではありません。お客様は、これらのリソースを自身で使用した結果発生するあらゆる申し立て、損害、費用、損失、責任について、TI およびその代理人を完全に補償するものとし、TI は一切の責任を拒否します。

TI の製品は、[TI の販売条件](#)、または [ti.com](#) やかかる TI 製品の関連資料などのいずれかを通じて提供する適用可能な条項の下で提供されています。TI がこれらのリソースを提供することは、適用される TI の保証または他の保証の放棄の拡大や変更を意味するものではありません。

お客様がいかなる追加条項または代替条項を提案した場合でも、TI はそれらに異議を唱え、拒否します。

郵送先住所：Texas Instruments, Post Office Box 655303, Dallas, Texas 75265
Copyright © 2024, Texas Instruments Incorporated