

LV2862 60V、600mA、高効率、広い入力電圧範囲、降圧コンバータ

1 特長

- 入力範囲は 4V~60V、65V の過渡電圧に対応
- 770kHz (X バージョン) または 2.1MHz (Y バージョン) のスイッチング周波数
- Eco-mode により軽負荷時に極めて高い効率を実現
- 低ドロップアウト動作
- 出力電流最大 600mA
- 高電圧高精度イネーブル入力
- 過電流保護
- 過熱保護
- 内部補償
- 内部ソフトスタート
- ソリューション全体のサイズの小型化 (SOT-6L パッケージ)

2 アプリケーション

- グリッド・インフラストラクチャ
- 電化製品
- モーター駆動
- V_{IN} が広い汎用電源

3 概要

LV2862 は PWM DC/DC バック (降圧型) レギュレータです。このデバイスは 4V~60V の広い入力電圧範囲で動

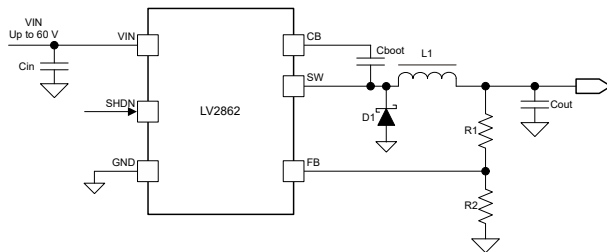

概略回路図

作し、産業用から車載用まで、非レギュレーション電源からの電源調整を行うさまざまなアプリケーション向けに設計されています。シャットダウン電流も $1\mu\text{A}$ と極めて低いことから、バッテリー駆動時間のさらなる延長が可能です。動作周波数は 770kHz (X バージョン) および 2.1MHz (Y バージョン) に固定され、小型の外部部品を使用可能にしながら、低い出力リップル電圧を実現しています。ソフト・スタートと補償回路が内部に実装されており、最小限の外付け部品のみにデバイスを使用できます。

LV2862 は最大 600mA の負荷電流に対して最適化されています。このデバイスの公称フィードバック電圧は 0.765V です。

このデバイスには、パルス単位の電流制限、熱センシング、過剰な消費電力によるサーマル・シャットダウンなどの保護機能が組み込まれています。LV2862 は、低プロファイルの SOT-6L パッケージで供給されます。

パッケージ情報

部品番号	パッケージ (1)	パッケージ・サイズ (2)
LV2862	DDC (SOT, 6)	2.90mm × 2.8mm

- (1) 利用可能なすべてのパッケージについては、データシートの末尾にある注文情報を参照してください。
- (2) パッケージ・サイズ (長さ×幅) は公称値であり、該当する場合はピンも含まれます。

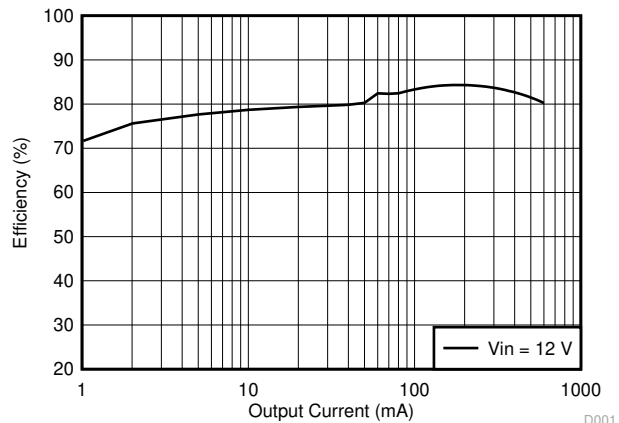

効率と出力電流との関係
 $(f_{sw} = 0.7\text{MHz}, V_{OUT} = 3.3\text{V})$



Table of Contents

1 特長.....	1	7.4 Device Functional Modes.....	9
2 アプリケーション.....	1	8 Application and Implementation.....	10
3 概要.....	1	8.1 Application Information.....	10
4 Revision History.....	2	8.2 Typical Application.....	10
5 Pin Configuration and Functions.....	3	8.3 Power Supply Recommendations.....	15
6 Specifications.....	4	8.4 Layout.....	15
6.1 Absolute Maximum Ratings.....	4	9 Device and Documentation Support.....	17
6.2 ESD Ratings.....	4	9.1 Documentation Support.....	17
6.3 Recommended Operating Conditions.....	4	9.2 ドキュメントの更新通知を受け取る方法.....	17
6.4 Thermal Information.....	4	9.3 サポート・リソース.....	17
6.5 Electrical Characteristics.....	5	9.4 Trademarks.....	17
6.6 Typical Characteristics.....	6	9.5 静電気放電に関する注意事項.....	17
7 Detailed Description.....	7	9.6 用語集.....	17
7.1 Overview.....	7	10 Mechanical, Packaging, and Orderable Information.....	17
7.2 Functional Block Diagram.....	7		
7.3 Feature Description.....	7		

4 Revision History

資料番号末尾の英字は改訂を表しています。その改訂履歴は英語版に準じています。

Changes from Revision A (June 2020) to Revision B (June 2023)	Page
• ドキュメント全体にわたって表、図、相互参照の採番方法を更新.....	1
• 「パッケージ情報」表のフォーマットを更新.....	1
• Moved storage temperature row from the <i>Handling Ratings</i> table to the <i>Absolute Maximum Ratings</i> table.....	4
• Updated the <i>Handling Ratings</i> table to <i>ESD Ratings</i> table.....	4
• Corrected part number typo in the <i>Power Supply Recommendations</i> section.....	15

Changes from Revision * (December 2014) to Revision A (June 2020)	Page
• 最初の公開リリース.....	1

5 Pin Configuration and Functions



图 5-1. SOT (DDC) 6 Pins Top View

表 5-1. Pin Functions

PIN		DESCRIPTION
NAME	NO.	
CB	1	Switch FET gate bias voltage. Connect C_{boot} cap between CB and SW.
GND	2	Ground connection
FB	3	Set feedback voltage divider ratio with $V_{OUT} = V_{FB} (1 + (R1 / R2))$
SHDN	4	Enable and disable input (high voltage tolerant). Internal pullup current source. Pull below 1.25 V to disable. Float to enable. Establish the input undervoltage lockout with a two-resistor divider.
V_{IN}	5	Power input voltage pin. Input for internal supply and drain node input for internal high-side MOSFET.
SW	6	Switch node. Connect to inductor, diode, and C_{boot} cap.

6 Specifications

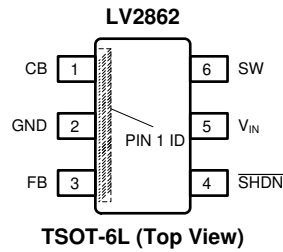
6.1 Absolute Maximum Ratings

Over operating free-air temperature range (unless otherwise noted) ⁽¹⁾

		MIN	MAX	UNIT
Input voltages	V _{IN} to GND	-0.3	65	V
	SHDN to GND	-0.3	65	
	FB to GND	-0.3	7	
	CB to SW	-0.3	7	
Output voltages	SW to GND	-1	65	
	SW to GND less than 30-ns transients	-2	65	
T _J operating junction temperature		-40	150	°C
T _{stg} storage temperature range		-55	165	°C

- (1) Stresses beyond those listed under *Absolute Maximum Ratings* may cause permanent damage to the device. These are stress ratings only, which do not imply functional operation of the device at these or any other conditions beyond those indicated under *Recommended Operating Conditions*. Exposure to absolute-maximum-rated conditions for extended periods may affect device reliability.

6.2 ESD Ratings

			MIN	MAX	UNIT
V _(ESD)	Electrostatic discharge	Human body model (HBM), per ANSI/ESDA/JEDEC JS-001, all pins ⁽¹⁾		2000	V
		Charged device model (CDM), per JEDEC specification JESD22-C101, all pins ⁽²⁾		500	

- (1) JEDEC document JEP155 states that 500-V HBM allows safe manufacturing with a standard ESD control process.
(2) JEDEC document JEP157 states that 250-V CDM allows safe manufacturing with a standard ESD control process.

6.3 Recommended Operating Conditions

over operating free-air temperature range (unless otherwise noted)

		MIN	MAX	UNIT
Buck Regulator	V _{IN}	4	60	V
	CB	4	66	
	CB to SW	-0.3	6	
	SW	-1	60	
	FB	0	5	
Control	SHDN	0	60	V
Temperature	Operating junction temperature, T _J	-40	125	°C

6.4 Thermal Information

THERMAL METRIC ⁽¹⁾		LV2862	UNIT
		TSOT	
		6 PINS	
R _{θJA}	Junction-to-ambient thermal resistance	102	°C/W
R _{θJC(top)}	Junction-to-case (top) thermal resistance	36.9	
R _{θJB}	Junction-to-board characterization parameter	28.4	

- (1) All numbers apply for packages soldered directly onto a 3" x 3" PC board with 2 oz. copper on 4 layers in still air in accordance to JEDEC standards. Thermal resistance varies greatly with layout, copper thickness, number of layers in PCB, power distribution,

number of thermal vias, board size, ambient temperature, and air flow. For more information about traditional and new thermal metrics, see the *IC Package Thermal Metrics* application report, [SPRA953](#).

6.5 Electrical Characteristics

$V_{IN} = 12\text{ V}$, $\overline{\text{SHDN}} = V_{IN}$. $T_J = 25^\circ\text{C}$ unless otherwise noted.

PARAMETER	CONDITION	MIN	TYP	MAX	UNIT
VIN (Input Power Supply)					
Operating input voltage		4		60	V
Shutdown supply current	EN = 0 V		1	3	μA
Undervoltage lockout thresholds	Rising			4	V
	Falling	3			V
I_Q	Eco-mode, no load, $V_{IN} = 12\text{ V}$, not switching		28		μA
SHDN and UVLO					
Rising $\overline{\text{SHDN}}$ Threshold Voltage		1.05	1.25	1.38	V
$\overline{\text{SHDN}}$ PIN current	SHDN = 2.3 V		-4.2		μA
	SHDN = 0.9 V		-1		μA
Hysteresis current			-3		μA
HIGH-SIDE MOSFET					
On-resistance	$V_{IN} = 12\text{ V}$, CB to SW = 5.8 V		900		m Ω
$t_{\text{ON-min}}$	$f_{\text{SW}} = 2.1\text{ MHz}$		80		ns
D_{MAX} : Maximum duty cycle			96%		
V_{FB} : Feedback voltage		0.74	0.765	0.79	V
CURRENT LIMIT					
Peak Current limit threshold			1200		mA
f_{SW} Switching frequency	LV2862X	560	770	980	kHz
	LV2862Y	1785	2100	2415	
THERMAL PERFORMANCE					
T_{SHUTDOWN} Thermal shutdown trip point			170		$^\circ\text{C}$
T_{hys}	Hysteresis		10		$^\circ\text{C}$

6.6 Typical Characteristics

Unless otherwise specified the following conditions apply: $V_{IN} = 12\text{ V}$, $SHDN = V_{IN}$, $T_A = 25^\circ\text{C}$

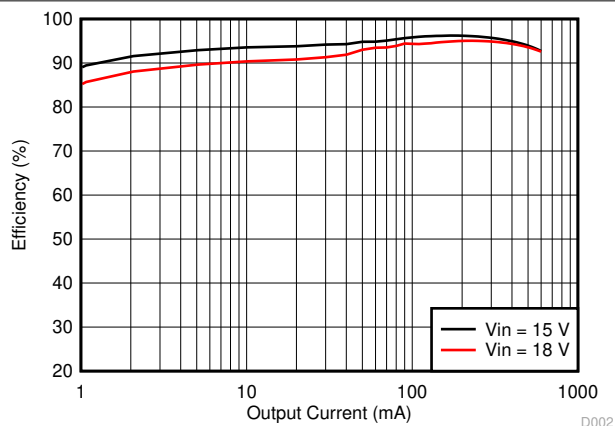

$V_{OUT} = 12\text{ V}$ $f_{SW} = 770\text{ kHz}$
 $L1 = 22\text{ }\mu\text{H}$ $C_{OUT} = 10\text{ }\mu\text{F}$

6-1. Efficiency versus Load Current

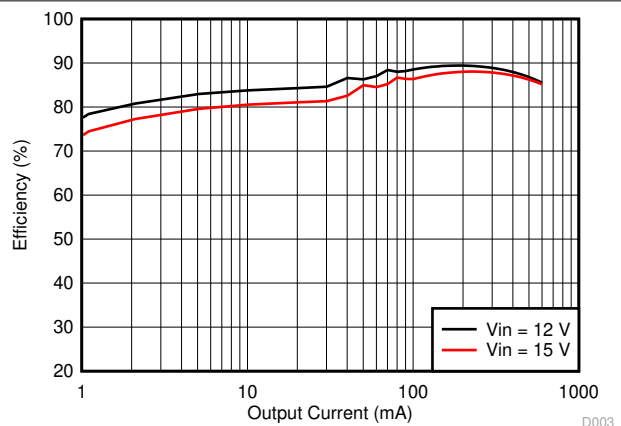

$V_{OUT} = 5\text{ V}$ $f_{SW} = 770\text{ kHz}$
 $L1 = 22\text{ }\mu\text{H}$ $C_{OUT} = 10\text{ }\mu\text{F}$

6-2. Efficiency versus Load Current

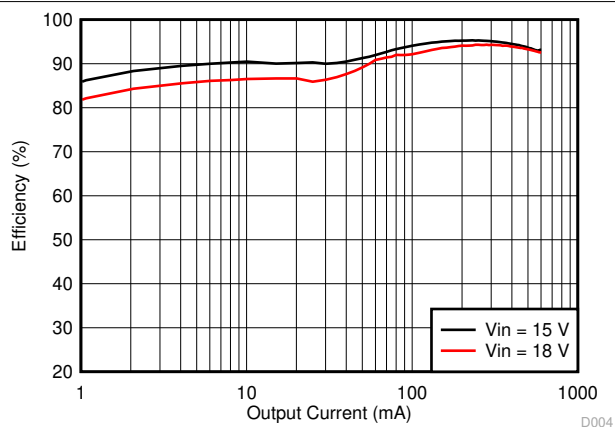

$V_{OUT} = 12\text{ V}$ $f_{SW} = 2.1\text{ MHz}$
 $L1 = 10\text{ }\mu\text{H}$ $C_{OUT} = 10\text{ }\mu\text{F}$

6-3. Efficiency versus Load Current

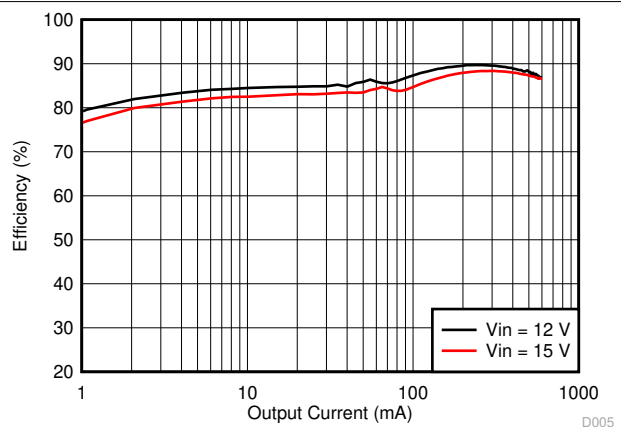

$V_{OUT} = 5\text{ V}$ $f_{SW} = 2.1\text{ MHz}$
 $L1 = 10\text{ }\mu\text{H}$ $C_{OUT} = 10\text{ }\mu\text{F}$

6-4. Efficiency versus Load Current

7 Detailed Description

7.1 Overview

The LV2862 device is a 60-V, 600-mA, step-down (buck) regulator. The buck regulator has a very low quiescent current during light load to prolong the battery life.

The LV2862 improves performance during line and load transients by implementing a constant frequency, current mode control which reduces output capacitance and simplifies frequency compensation design. The LV2862 reduces the external component count by integrating the boot recharge diode. The bias voltage for the integrated high-side MOSFET is supplied by a capacitor on the CB to SW pin. The boot capacitor voltage is monitored by a UVLO circuit and turns the high-side MOSFET off when the boot voltage falls below a preset threshold. The LV2862 can operate at high duty cycles because of the boot UVLO and refresh the wimp FET. The output voltage can be stepped down to as low as the 0.8 V. Internal soft start is featured to minimize inrush currents.

7.2 Functional Block Diagram

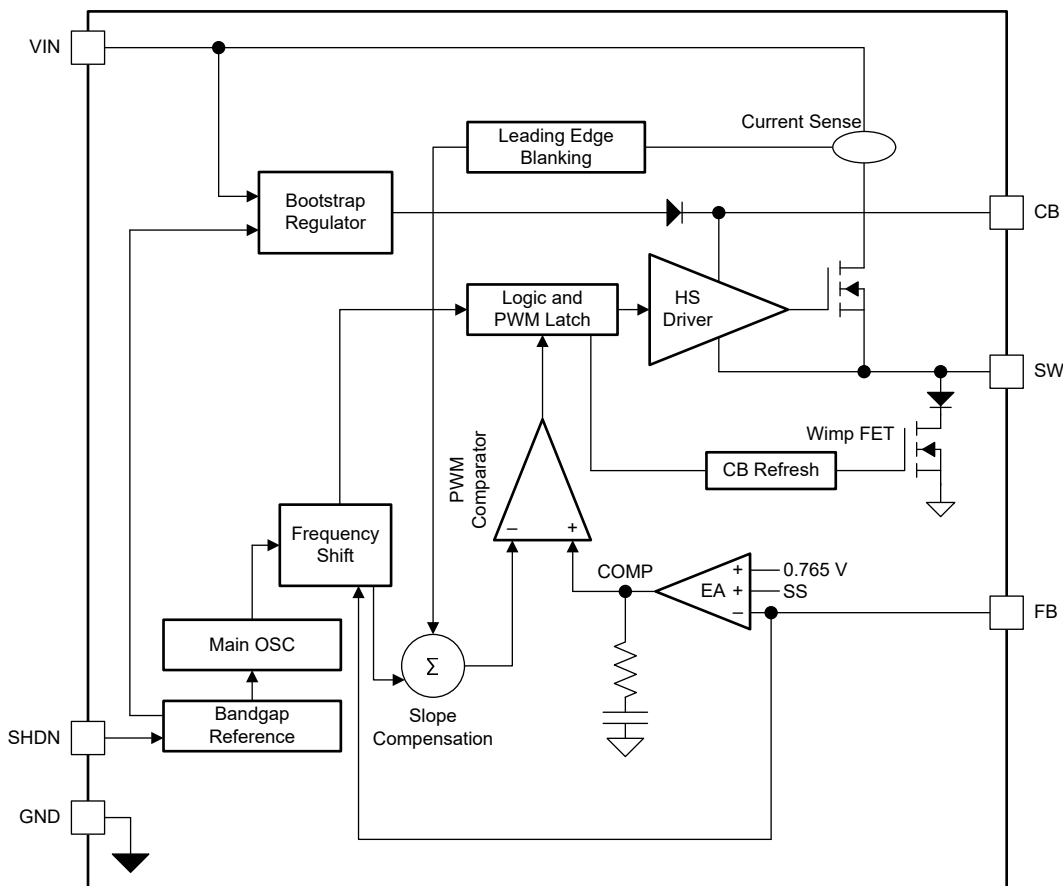

7.3 Feature Description

7.3.1 Continuous Conduction Mode

The LV2862 steps the input voltage down to a lower output voltage. In continuous conduction mode (when the inductor current never reaches zero at CCM), the buck regulator operates in two cycles. The power switch is connected between V_{IN} and SW. In the first cycle of operation, the transistor is closed and the diode is reverse biased. Energy is collected in the inductor and the load current is supplied by C_{out} and the rising current through the inductor. During the second cycle, the transistor is open and the diode is forward biased due to the fact that the inductor current cannot instantaneously change direction. The energy stored in the inductor is transferred to the load and output capacitor. The ratio of these two cycles determines the output voltage. The output voltage is

defined approximately as: $D = V_{OUT} / V_{IN}$ and $D' = (1 - D)$ where D is the duty cycle of the switch. D and D' are required for design calculations.

7.3.2 Fixed Frequency PWM Control

The LV2862 has two fixed frequency options and implements peak current mode control. The output voltage is compared through external resistors on the FB pin to an internal voltage reference by an error amplifier that drives the internal COMP node. An internal oscillator initiates the turnon of the high-side power switch. The error amplifier output is compared to the high-side power switch current. When the power switch current reaches the level set by the internal COMP voltage, the power switch is turned off. The internal COMP node voltage increases and decreases as the output current increases and decreases. The device implements a current limit by clamping the COMP node voltage to a maximum level.

7.3.3 Eco-mode

The LV2862 operates in Eco-mode at light load currents to improve efficiency by reducing switching and gate drive losses. For Eco-mode operation, the LV2862 senses peak current, not average or load current, so the load current where the device enters Eco-mode is dependent on V_{IN} , V_{OUT} , and the output inductor value. When the load current is low and the output voltage is within regulation, the device enters ECO mode (see [Figure 8-10](#)) and draws only 28- μ A input quiescent current.

7.3.4 Bootstrap Voltage (CB)

The LV2862 has an integrated boot regulator, and requires a small ceramic capacitor between the CB and SW pins to provide the gate drive voltage for the high-side MOSFET. The CB capacitor is refreshed when the high-side MOSFET is off and the low-side diode conducts.

To improve dropout, the LV2862 is designed to operate at 96% duty cycle as long as the CB to SW pin voltage is greater than 3 V. When the voltage from CB to SW drops below 3 V, the high-side MOSFET is turned off using an UVLO circuit which allows the low-side diode to conduct and refresh the charge on the CB capacitor. Because the supply current sourced from the CB capacitor is low, the high-side MOSFET can remain on for more switching cycles than is required to refresh the capacitor, thus the effective duty cycle of the switching regulator is high.

Attention must be taken in maximum duty cycle applications with light load. To ensure SW can be pulled to ground to refresh the CB capacitor, an internal circuit charges the CB capacitor when the load is light or the device is working in dropout condition.

7.3.5 Enable ($\overline{\text{SHDN}}$) and VIN Undervoltage Lockout (UVLO)

The LV2862 $\overline{\text{SHDN}}$ pin is a high-voltage tolerant input with an internal pullup circuit. The device can be enabled even if the $\overline{\text{SHDN}}$ pin is floating. The regulator can also be turned on using 1.25 V or higher logic signals. It can be used if the use of a higher voltage is desired due to system or other constraints. A 100-k Ω or larger resistor is recommended between the applied voltage and the $\overline{\text{SHDN}}$ pin to protect the device. When $\overline{\text{SHDN}}$ is pulled down to 0 V, the chip is turned off and enters the lowest shutdown current mode. In shutdown mode, the supply current is decreased to approximately 1 μ A. If the shutdown function is not to be used, the $\overline{\text{SHDN}}$ pin can be tied to V_{IN} through a 100-k Ω resistor. The maximum voltage to the $\overline{\text{SHDN}}$ pin must not exceed 60 V. The LV2862 has an internal UVLO circuit to shut down the output if the input voltage falls below an internally fixed UVLO threshold level. This ensures that the regulator is not latched into an unknown state during low input voltage conditions. The regulator powers up when the input voltage exceeds the voltage level. If there is a requirement for a higher UVLO voltage, the $\overline{\text{SHDN}}$ pin can be used to adjust the input voltage UVLO by using external resistors.

7.3.6 Setting the Output Voltage

The output voltage is set using the feedback pin and a resistor divider connected to the output as shown on the front page schematic. The feedback pin voltage is 0.765 V, so the ratio of the feedback resistors sets the output voltage according to [Equation 1](#):

$$V_{OUT} = 0.765 \text{ V} (1 + (R1 / R2)) \quad (1)$$

Typically, R2 is given as 1 kΩ–100 kΩ for a starting value. To solve for R1 given R2 and V_{OUT}, use $R1 = R2 \cdot ((V_{OUT} / 0.765 \text{ V}) - 1)$.

7.3.7 Current Limit

The LV2862 implements current mode control which uses the internal COMP voltage to turn off the high-side MOSFET on a cycle-by-cycle basis. Each cycle, the switch current and internal COMP voltage are compared. When the peak switch current intersects the COMP voltage, the high-side switch is turned off. During overcurrent conditions that pull the output voltage low, the error amplifier responds by driving the COMP node high, increasing the switch current. The error amplifier output is clamped internally, which functions as a switch current limit.

7.3.8 Thermal Shutdown

The device implements an internal thermal shutdown to protect itself if the junction temperature exceeds 170°C (typ). The thermal shutdown forces the device to stop switching when the junction temperature exceeds the thermal trip threshold. After the junction temperature decreases below 160°C (typ), the device reinitiates the power-up sequence.

7.4 Device Functional Modes

This device does not have any device functional modes.

8 Application and Implementation

注

以下のアプリケーション情報は、TI の製品仕様に含まれるものではなく、TI ではその正確性または完全性を保証いたしません。個々の目的に対する製品の適合性については、お客様の責任で判断していただくこととなります。お客様は自身の設計実装を検証しテストすることで、システムの機能を確認する必要があります。

8.1 Application Information

The LV2862 is a PWM DC/DC buck (step-down) regulator. With a wide input range from 4 V to 60 V, it is suitable for a wide range of applications from, industrial to automotive, for power conditioning from unregulated source. Soft start and compensation circuits are implemented internally, which allow the device to be used with minimized external components.

8.2 Typical Application



図 8-1. Application Circuit, 5-V Output

8.2.1 Design Requirements

8.2.1.1 Design Guide – Step By Step Design Procedure

表 8-1 details the design of a high frequency switching regulator using ceramic output capacitors. A few parameters must be known to start the design process. These parameters are typically determined at the system level:

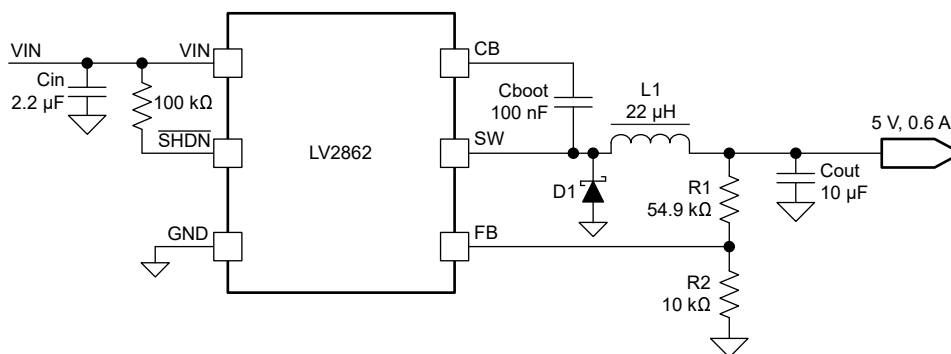
表 8-1. Design Parameters

Input Voltage, V_{IN}	9 V to 16 V, Typical 12 V	
Output Voltage, V_{OUT}	5.0 V \pm 3%	
Maximum Output Current Example I_{O_max}	0.6 A	
Minimum Output Current Example I_{O_min}	0.03 A	
Transient Response 0.03 A to 0.6 A	5%	
Output Voltage Ripple	1%	
Switching Frequency f_{SW}	770 kHz	
Target during Load Transient	Overvoltage Peak Value	106% of Output Voltage
	Undervoltage Value	91% of Output Voltage

8.2.2 Detailed Design Procedure

8.2.2.1 Selecting the Switching Frequency

The first step is to decide on a switching frequency for the regulator. Typically, choose the highest switching frequency possible because this switching frequency produces the smallest solution size. The high switching

frequency allows for lower valued inductors and smaller output capacitors compared to a power supply that switches at a lower frequency. The switching frequency that can be selected is limited by the minimum on-time of the internal power switch, the input voltage and the output voltage, and the frequency shift limitation. For this example, the output voltage is 5 V, the maximum input voltage is 16 V, and a switching frequency of 770 kHz is used.

8.2.2.2 Output Inductor Selection

The most critical parameters for the inductor are the inductance, peak current, and the DC resistance. The inductance is related to the peak-to-peak inductor ripple current, the input, and the output voltages. Because the ripple current increases with the input voltage, the maximum input voltage is always used to determine the inductance. To calculate the minimum value of the output inductor, use 式 1. A reasonable value for the ripple current is 40% (K_{IND}) of the DC output current. For this design example, the minimum inductor value is calculated to be 20.4 μH , and a nearest standard value was chosen: 22 μH . For the output filter inductor, it is important that the RMS current and saturation current ratings not be exceeded. The RMS and peak inductor current can be found in 式 3 and 式 4. The inductor ripple current is 0.22 A, and the RMS current is 0.6 A. As the equation set demonstrates, lower ripple currents reduce the output voltage ripple of the regulator but require a larger value of inductance. A good starting point for most applications is 22 μH with a 1.6-A current rating. Using a rating near 1.6 A enables the LV2862 to current limit without saturating the inductor. This is preferable to the LV2862 going into thermal shutdown mode and the possibility of damaging the inductor if the output is shorted to ground or other long-term overload.

$$L_{o \min} = \frac{V_{in \max} - V_{out}}{I_o \times K_{IND}} \times \frac{V_{out}}{V_{in \max} \times f_{sw}} \quad (2)$$

$$I_{ripple} = \frac{V_{out} \times (V_{in \max} - V_{out})}{V_{in \max} \times L_o \times f_{sw}} \quad (3)$$

$$I_{L-RMS} = \sqrt{I_o^2 + \frac{1}{12} I_{ripple}^2} \quad (4)$$

$$I_{L-peak} = I_o + \frac{I_{ripple}}{2} \quad (5)$$

8.2.2.3 Output Capacitor Selection

The selection of C_{OUT} is mainly driven by three primary considerations. The output capacitor determines the modulator pole, the output voltage ripple, and how the regulator responds to a large change in load current. The output capacitance needs to be selected based on the most stringent of these three criteria.

The first criterion is the desired response to a large change in the load current. The regulator usually needs two or more clock cycles for the control loop to see the change in load current and output voltage and adjust the duty cycle to react to the change. The output capacitance must be large enough to supply the difference in current for two clock cycles while only allowing a tolerable amount of droop in the output voltage. 式 5 shows the minimum output capacitance necessary to accomplish this. The transient load response is specified as a 3% change in V_{OUT} for a load step from 0.03 A to 0.6 A (full load), $\Delta I_{OUT} = 0.6 - 0.03 = 0.57$ A and $\Delta V_{OUT} = 0.03 \times 5 = 0.15$ V. Using these numbers gives a minimum capacitance of 10.8 μF . For ceramic capacitors, the ESR is usually small enough to ignore in this calculation. Aluminum electrolytic and tantalum capacitors have higher ESR that must be taken into account.

The stored energy in the inductor produces an output voltage overshoot when the load current rapidly decreases. The output capacitor must also be sized to absorb energy stored in the inductor when transitioning from a high load current to a lower load current. 式 6 is used to calculate the minimum capacitance to keep the output voltage overshoot to a desired value. Where L is the value of the inductor, I_{OH} , is the output current under heavy load, I_{OL} is the output under light load, V_f is the final peak output voltage, and V_i is the initial capacitor voltage. For this example, the worst case load step is from 0.6 A to 0.03 A. The output voltage increases during

this load transition and the stated maximum in our specification is 3% of the output voltage. This makes $V_{o_overshoot} = 1.03 \times 5 = 5.15$ V. V_i is the initial capacitor voltage which is the nominal output voltage of 5 V. Using these numbers in 式 6 yields a minimum capacitance of 5.2 μ F.

式 7 calculates the minimum output capacitance needed to meet the output voltage ripple specification where f_{sw} is the switching frequency, V_{o_ripple} is the maximum allowable output voltage ripple, and I_{L_ripple} is the inductor ripple current. 式 7 yields 0.26 μ F. 式 8 calculates the maximum ESR an output capacitor can have to meet the output voltage ripple specification. indicates the ESR must be less than 680 m Ω .

Additional capacitance de-ratings for aging, temperature, and dc bias must be factored in which increases this minimum value. For this example, 10- μ F ceramic capacitors are used. Capacitors in the range of 10 μ F–100 μ F are a good starting point with an ESR of 0.7 Ω or less.

$$C_{out} > \frac{2 \times \Delta I_{out}}{f_{sw} \times \Delta V_{out}} \quad (6)$$

$$C_{out} > L_o \times \frac{(I_{oh}^2 - I_{ol}^2)}{(V_f^2 - V_i^2)} \quad (7)$$

$$C_{out} > \frac{1}{8 \times f_{sw}} \times \frac{1}{\frac{V_{o_ripple}}{I_{L_ripple}}} \quad (8)$$

$$R_{ESR} < \frac{V_{o_ripple}}{I_{L_ripple}} \quad (9)$$

8.2.2.4 Schottky Diode Selection

The breakdown voltage rating of the diode is preferred to be 25% higher than the maximum input voltage. In the target application, the current rating for the diode must be equal to the maximum output current for best reliability in most applications. In cases where the input voltage is not much greater than the output voltage, the average diode current is lower. In this case, it is possible to use a diode with a lower average current rating, approximately $(1 - D) \times I_{OUT}$. However, the peak current rating must be higher than the maximum load current. A 0.5-A to 1-A rated diode is a good starting point.

8.2.2.5 Input Capacitor Selection

A low ESR ceramic capacitor is needed between the VIN pin and ground pin. This capacitor prevents large voltage transients from appearing at the input. Use a 2.2 μ F–10 μ F value with X5R or X7R dielectric. Depending on construction, the value of a ceramic capacitor can decrease up to 50% of its nominal value when rated voltage is applied. Consult with the capacitor manufacturer's data sheet for information on capacitor derating over voltage and temperature. The capacitor must also have a ripple current rating greater than the maximum input current ripple of the LV2862. The input ripple current can be calculated using 式 10 and 式 11.

For this example design, one 4.7- μ F, 50-V capacitor is selected. The input capacitance value determines the input ripple voltage of the regulator. The input voltage ripple can be calculated using 式 10. Using the design example values, $I_{outmax} = 0.6$ A, $C_{in} = 2.2$ μ F, and $f_{sw} = 770$ kHz yields an input voltage ripple of 97 mV and an RMS input ripple current of 0.3 A.

$$I_{cirms} = I_{out} \times \sqrt{\frac{V_{out}}{V_{in\ min}} \times \frac{(V_{in\ min} - V_{out})}{V_{in\ min}}} \quad (10)$$

$$\Delta V_{in} = \frac{I_{out\ max} \times 0.25}{C_{in} \times f_{sw}} \quad (11)$$

8.2.2.5.1 Bootstrap Capacitor Selection

A 0.1- μF ceramic capacitor or larger is recommended for the bootstrap capacitor (C_{BOOT}). For applications where the input voltage is close to output voltage, a larger capacitor is recommended, generally 0.1 μF to 1 μF to ensure plenty of gate drive for the internal switches and a consistently low $R_{\text{DS(ON)}}$. A ceramic capacitor with an X7R or X5R grade dielectric with a voltage rating of 10 V or higher is recommended because of the stable characteristics over temperature and voltage.

表 8-2. Output Voltage Inductor and Capacitor Combinations

P/N	V_{OUT} (V)	R1 (k Ω)	R2 (k Ω)	L (μH)	C_{OUT} (μF)
LV2862X	5	54.9 (1%)	10 (1%)	22	10
LV2862X	5.7	64.9 (1%)	10 (1%)	22	10
LV2862X	12	147 (1%)	10 (1%)	22	10

8.2.2.5.1.1 Typical Application Circuits



图 8-2. Application Circuit, 5.7-V Output



图 8-3. Application Circuit, 12-V Output

表 8-2 lists the recommended typical output voltage inductor/capacitor combinations for optimized total solution size.

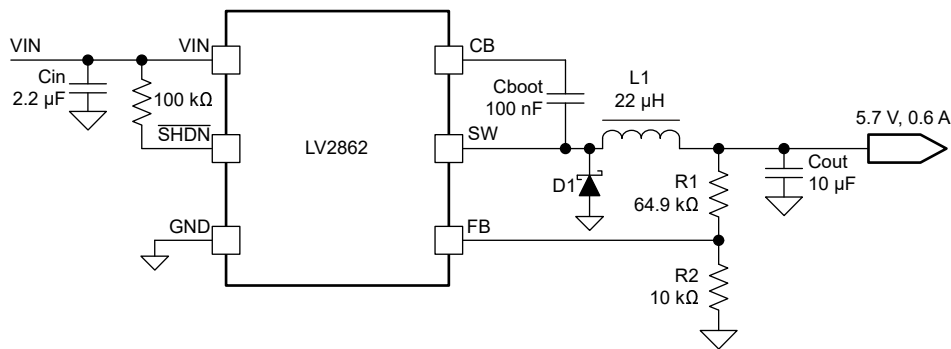
8.2.3 Application Curves

Unless otherwise specified the following conditions apply: $V_{IN} = 12\text{ V}$, $f_{SW} = 770\text{ kHz}$, $L = 22\text{ }\mu\text{H}$, $C_{OUT} = 10\text{ }\mu\text{F}$, $T_A = 25^\circ\text{C}$

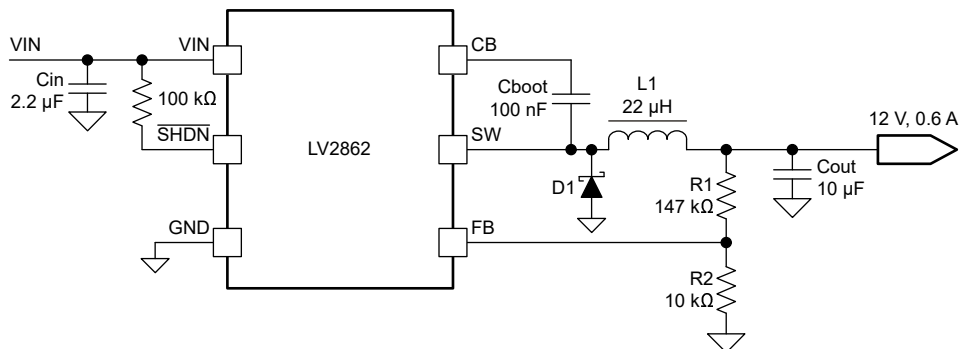
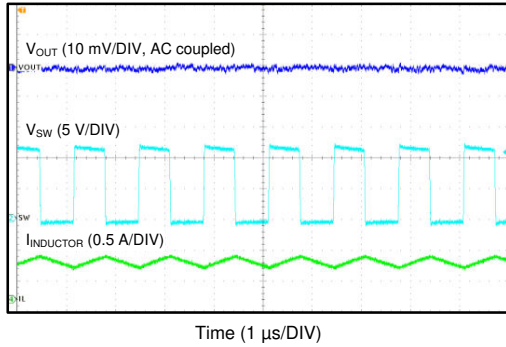

$V_{OUT} = 5\text{ V}$ $I_{OUT} = 600\text{ mA}$

8-4. Switching Node and Output Voltage Waveform

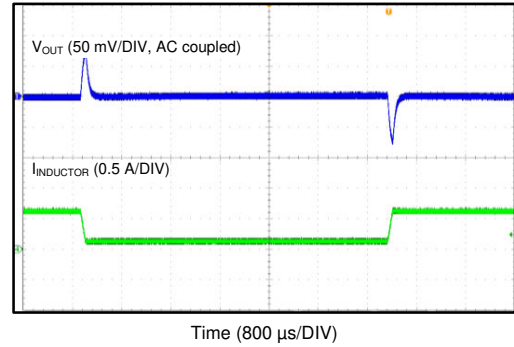

$V_{OUT} = 5\text{ V}$

8-5. Load Transient Between 0.1 A and 0.6 A

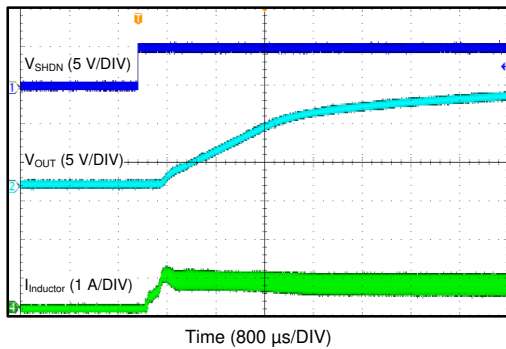

$V_{IN} = 15\text{ V}$ $V_{OUT} = 12\text{ V} / 600\text{ mA}$

8-6. Start-up Waveform

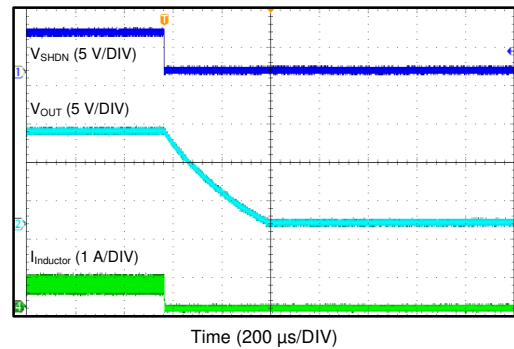

$V_{IN} = 15\text{ V}$ $V_{OUT} = 12\text{ V} / 600\text{ mA}$

8-7. Shutdown Waveform

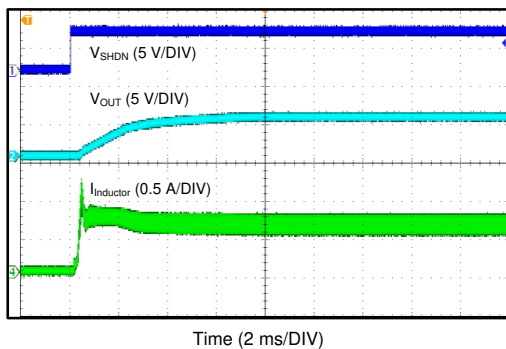

$V_{IN} = 12\text{ V}$ $V_{OUT} = 5\text{ V} / 600\text{ mA}$

8-8. Start-up Waveform

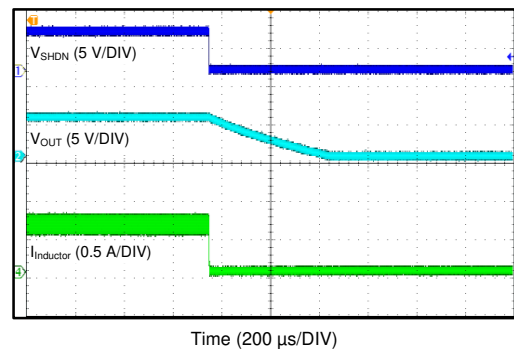

$V_{IN} = 12\text{ V}$ $V_{OUT} = 5\text{ V} / 600\text{ mA}$

8-9. Shutdown Waveform

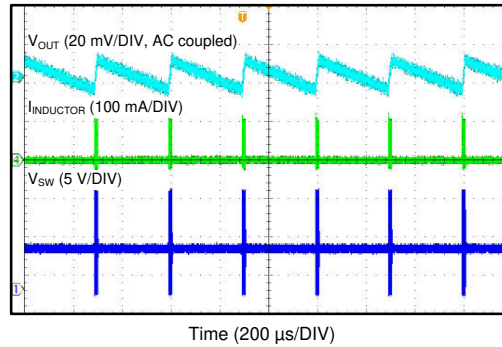

$V_{IN} = 12\text{ V}$

$V_{OUT} = 5\text{ V} / \text{No Load}$

图 8-10. Eco-mode Operation

8.3 Power Supply Recommendations

The LV2862 is designed to operate from an input voltage supply range between 4 V and 60 V. This input supply must be able to withstand the maximum input current and maintain a voltage above 4 V. The resistance of the input supply rail must be low enough that an input current transient does not cause a high enough drop at the LV2862 supply voltage that can cause a false UVLO fault triggering and system reset. If the input supply is located more than a few inches from the LV2862, additional bulk capacitance can be required in addition to the ceramic input capacitors.

8.4 Layout

8.4.1 Layout Guidelines

Layout is a critical portion of good power supply design. The following guidelines helps users design a PCB with the best power conversion performance, thermal performance, and minimized generation of unwanted EMI.

1. The feedback network, resistors R1 and R2, must be kept close to the FB pin and away from the inductor to minimize coupling noise into the feedback pin.
2. The input capacitor C_{IN} must be placed close to the V_{IN} pin. This reduces copper trace inductance which affects input voltage ripple of the IC.
3. The inductor L1 must be placed close to the SW pin to reduce magnetic and electrostatic noise.
4. The output capacitor C_{OUT} must be placed close to the junction of L1 and the diode D1. The L1, D1, and C_{OUT} trace must be as short as possible to reduce conducted and radiated noise.
5. The ground connection for the diode, C_{IN} and C_{OUT} must be tied to the system ground plane in only one spot (preferably at the C_{OUT} ground point) to minimize conducted noise in the system ground plane.
6. For more detail on switching power supply layout considerations, see Application Note AN-1149, [Layout Guidelines for Switching Power Supplies](#).

8.4.2 Layout Example

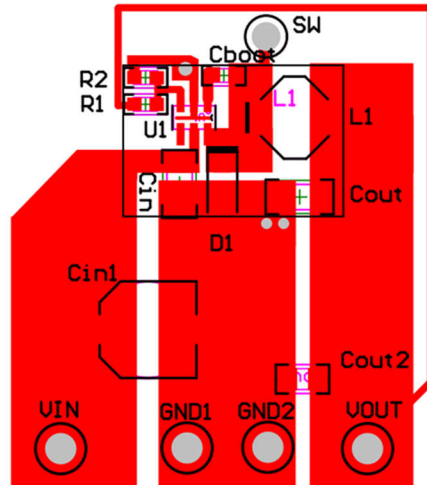

8-11. Layout Example

9 Device and Documentation Support

9.1 Documentation Support

9.1.1 Related Documentation

Texas Instruments, [Layout Guidelines for Switching Power Supplies](#) application report

9.2 ドキュメントの更新通知を受け取る方法

ドキュメントの更新についての通知を受け取るには、[ti.com](#) のデバイス製品フォルダを開いてください。「更新の通知を受け取る」をクリックして登録すると、変更されたすべての製品情報に関するダイジェストを毎週受け取れます。変更の詳細については、修正されたドキュメントに含まれている改訂履歴をご覧ください。

9.3 サポート・リソース

[TI E2E™ サポート・フォーラム](#)は、エンジニアが検証済みの回答と設計に関するヒントをエキスパートから迅速かつ直接得ることができる場所です。既存の回答を検索したり、独自の質問をしたりすることで、設計に必要な支援を迅速に得ることができます。

リンクされているコンテンツは、該当する貢献者により、現状のまま提供されるものです。これらは TI の仕様を構成するものではなく、必ずしも TI の見解を反映したものではありません。TI の [使用条件](#)を参照してください。

9.4 Trademarks

TI E2E™ is a trademark of Texas Instruments.

すべての商標は、それぞれの所有者に帰属します。

9.5 静電気放電に関する注意事項



この IC は、ESD によって破損する可能性があります。テキサス・インスツルメンツは、IC を取り扱う際には常に適切な注意を払うことを推奨します。正しい取り扱いおよび設置手順に従わない場合、デバイスを破損するおそれがあります。

ESD による破損は、わずかな性能低下からデバイスの完全な故障まで多岐にわたります。精密な IC の場合、パラメータがわずかに変化するだけで公表されている仕様から外れる可能性があるため、破損が発生しやすくなっています。

9.6 用語集

[テキサス・インスツルメンツ用語集](#) この用語集には、用語や略語の一覧および定義が記載されています。

10 Mechanical, Packaging, and Orderable Information

The following pages include mechanical, packaging, and orderable information. This information is the most current data available for the designated devices. This data is subject to change without notice and revision of this document. For browser-based versions of this data sheet, refer to the left-hand navigation.

PACKAGING INFORMATION

Orderable Device	Status (1)	Package Type	Package Drawing	Pins	Package Qty	Eco Plan (2)	Lead finish/ Ball material (6)	MSL Peak Temp (3)	Op Temp (°C)	Device Marking (4/5)	Samples
LV2862XLVDDCR	ACTIVE	SOT-23-THIN	DDC	6	3000	RoHS & Green	NIPDAU	Level-1-260C-UNLIM	-40 to 125	C02X	Samples
LV2862XLVDDCT	ACTIVE	SOT-23-THIN	DDC	6	250	RoHS & Green	NIPDAU	Level-1-260C-UNLIM	-40 to 125	C02X	Samples
LV2862YDDCR	ACTIVE	SOT-23-THIN	DDC	6	3000	RoHS & Green	NIPDAU	Level-1-260C-UNLIM	-40 to 125	C02Y	Samples
LV2862YDDCT	ACTIVE	SOT-23-THIN	DDC	6	250	RoHS & Green	NIPDAU	Level-1-260C-UNLIM	-40 to 125	C02Y	Samples

(1) The marketing status values are defined as follows:

ACTIVE: Product device recommended for new designs.

LIFEBUY: TI has announced that the device will be discontinued, and a lifetime-buy period is in effect.

NRND: Not recommended for new designs. Device is in production to support existing customers, but TI does not recommend using this part in a new design.

PREVIEW: Device has been announced but is not in production. Samples may or may not be available.

OBSOLETE: TI has discontinued the production of the device.

(2) **RoHS:** TI defines "RoHS" to mean semiconductor products that are compliant with the current EU RoHS requirements for all 10 RoHS substances, including the requirement that RoHS substance do not exceed 0.1% by weight in homogeneous materials. Where designed to be soldered at high temperatures, "RoHS" products are suitable for use in specified lead-free processes. TI may reference these types of products as "Pb-Free".

RoHS Exempt: TI defines "RoHS Exempt" to mean products that contain lead but are compliant with EU RoHS pursuant to a specific EU RoHS exemption.

Green: TI defines "Green" to mean the content of Chlorine (Cl) and Bromine (Br) based flame retardants meet JS709B low halogen requirements of <=1000ppm threshold. Antimony trioxide based flame retardants must also meet the <=1000ppm threshold requirement.

(3) MSL, Peak Temp. - The Moisture Sensitivity Level rating according to the JEDEC industry standard classifications, and peak solder temperature.

(4) There may be additional marking, which relates to the logo, the lot trace code information, or the environmental category on the device.

(5) Multiple Device Markings will be inside parentheses. Only one Device Marking contained in parentheses and separated by a "-" will appear on a device. If a line is indented then it is a continuation of the previous line and the two combined represent the entire Device Marking for that device.

(6) Lead finish/Ball material - Orderable Devices may have multiple material finish options. Finish options are separated by a vertical ruled line. Lead finish/Ball material values may wrap to two lines if the finish value exceeds the maximum column width.

Important Information and Disclaimer:The information provided on this page represents TI's knowledge and belief as of the date that it is provided. TI bases its knowledge and belief on information provided by third parties, and makes no representation or warranty as to the accuracy of such information. Efforts are underway to better integrate information from third parties. TI has taken and

continues to take reasonable steps to provide representative and accurate information but may not have conducted destructive testing or chemical analysis on incoming materials and chemicals. TI and TI suppliers consider certain information to be proprietary, and thus CAS numbers and other limited information may not be available for release.

In no event shall TI's liability arising out of such information exceed the total purchase price of the TI part(s) at issue in this document sold by TI to Customer on an annual basis.

TAPE AND REEL INFORMATION

QUADRANT ASSIGNMENTS FOR PIN 1 ORIENTATION IN TAPE



*All dimensions are nominal

Device	Package Type	Package Drawing	Pins	SPQ	Reel Diameter (mm)	Reel Width W1 (mm)	A0 (mm)	B0 (mm)	K0 (mm)	P1 (mm)	W (mm)	Pin1 Quadrant
LV2862XLVDDCR	SOT-23-THIN	DDC	6	3000	178.0	8.4	3.2	3.2	1.4	4.0	8.0	Q3
LV2862XLVDDCT	SOT-23-THIN	DDC	6	250	178.0	8.4	3.2	3.2	1.4	4.0	8.0	Q3
LV2862XLVDDCT	SOT-23-THIN	DDC	6	250	180.0	8.4	3.1	3.05	1.1	4.0	8.0	Q3
LV2862YDDCR	SOT-23-THIN	DDC	6	3000	178.0	8.4	3.2	3.2	1.4	4.0	8.0	Q3
LV2862YDDCT	SOT-23-THIN	DDC	6	250	178.0	8.4	3.2	3.2	1.4	4.0	8.0	Q3

TAPE AND REEL BOX DIMENSIONS

*All dimensions are nominal

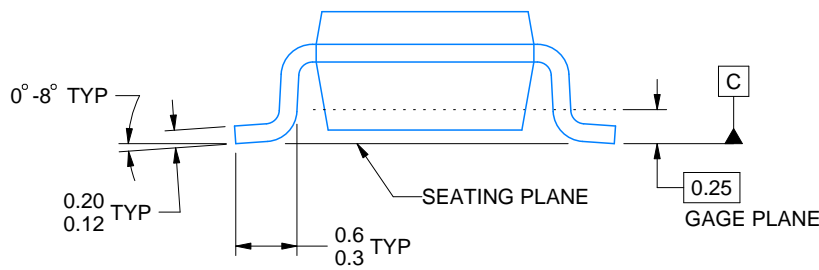
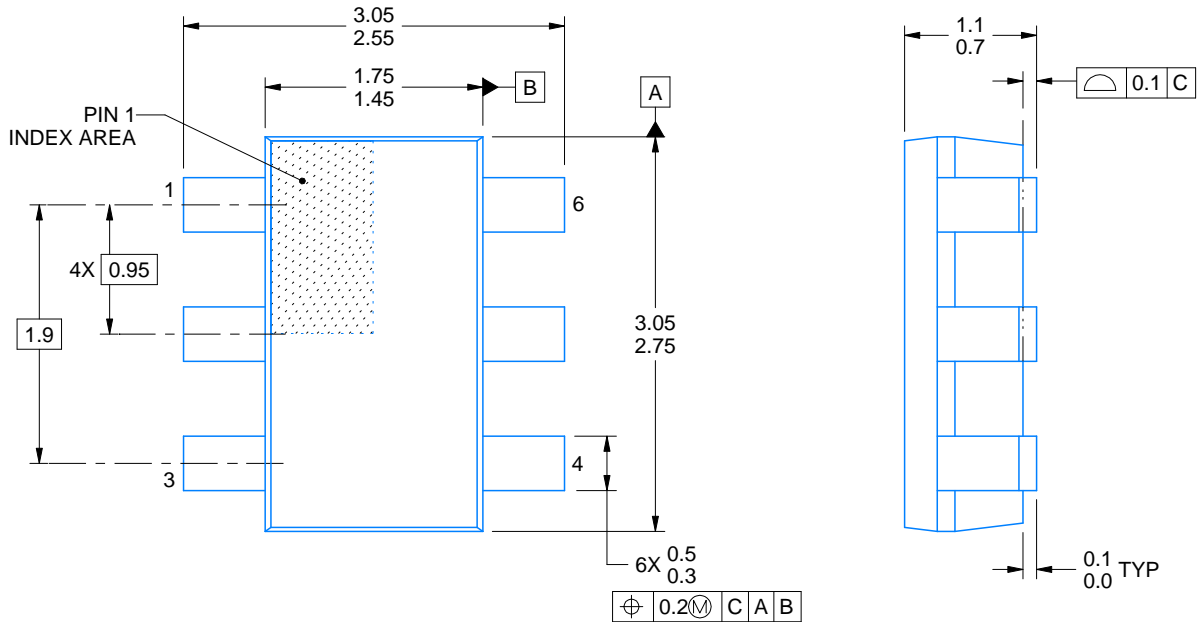
Device	Package Type	Package Drawing	Pins	SPQ	Length (mm)	Width (mm)	Height (mm)
LV2862XLVDDCR	SOT-23-THIN	DDC	6	3000	208.0	191.0	35.0
LV2862XLVDDCT	SOT-23-THIN	DDC	6	250	208.0	191.0	35.0
LV2862XLVDDCT	SOT-23-THIN	DDC	6	250	183.0	183.0	20.0
LV2862YDDCR	SOT-23-THIN	DDC	6	3000	208.0	191.0	35.0
LV2862YDDCT	SOT-23-THIN	DDC	6	250	208.0	191.0	35.0



ALTERNATIVE PACKAGE SINGULATION VIEW

4214841/D 06/2024

NOTES:

- 1. All linear dimensions are in millimeters. Any dimensions in parenthesis are for reference only. Dimensioning and tolerancing per ASME Y14.5M.
- 2. This drawing is subject to change without notice.
- 3. Reference JEDEC MO-193.

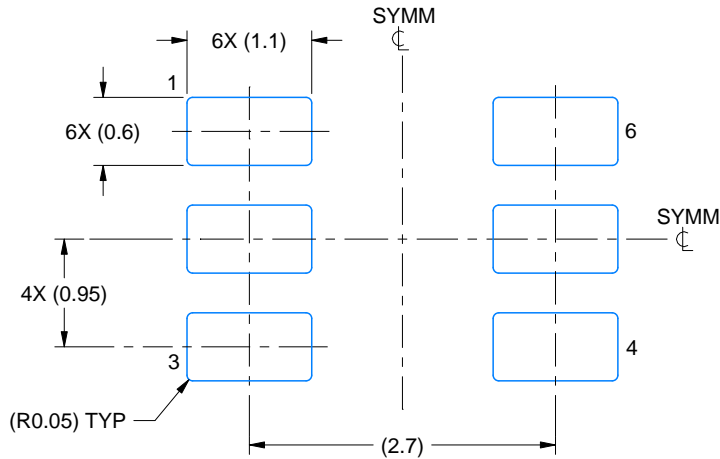

LAND PATTERN EXAMPLE
EXPLODED METAL SHOWN
SCALE:15X

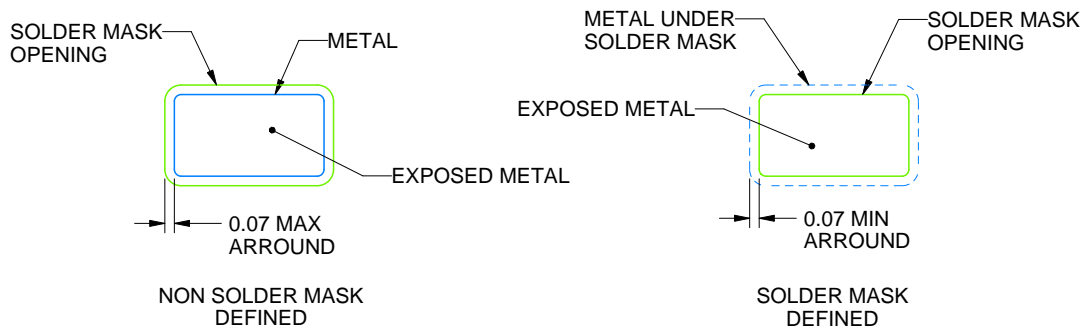

SOLDEMASK DETAILS

4214841/D 06/2024

NOTES: (continued)

- 4. Publication IPC-7351 may have alternate designs.
- 5. Solder mask tolerances between and around signal pads can vary based on board fabrication site.

EXAMPLE STENCIL DESIGN

DDC0006A

SOT-23 - 1.1 max height

SMALL OUTLINE TRANSISTOR

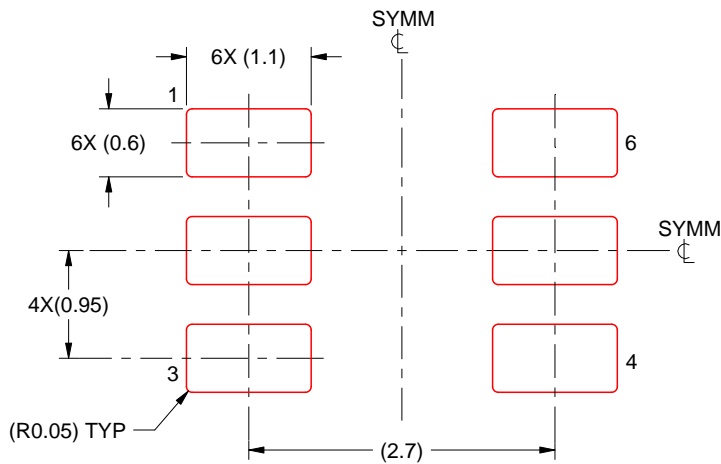

SOLDER PASTE EXAMPLE
BASED ON 0.125 THICK STENCIL
SCALE:15X

4214841/D 06/2024

NOTES: (continued)

6. Laser cutting apertures with trapezoidal walls and rounded corners may offer better paste release. IPC-7525 may have alternate design recommendations.
7. Board assembly site may have different recommendations for stencil design.

重要なお知らせと免責事項

TI は、技術データと信頼性データ（データシートを含みます）、設計リソース（リファレンス・デザインを含みます）、アプリケーションや設計に関する各種アドバイス、Web ツール、安全性情報、その他のリソースを、欠陥が存在する可能性のある「現状のまま」提供しており、商品性および特定目的に対する適合性の黙示保証、第三者の知的財産権の非侵害保証を含むいかなる保証も、明示的または黙示的にかかわらず拒否します。

これらのリソースは、TI 製品を使用する設計の経験を積んだ開発者への提供を意図したものです。(1) お客様のアプリケーションに適した TI 製品の選定、(2) お客様のアプリケーションの設計、検証、試験、(3) お客様のアプリケーションに該当する各種規格や、その他のあらゆる安全性、セキュリティ、規制、または他の要件への確実な適合に関する責任を、お客様のみが単独で負うものとし、

上記の各種リソースは、予告なく変更される可能性があります。これらのリソースは、リソースで説明されている TI 製品を使用するアプリケーションの開発の目的でのみ、TI はその使用をお客様に許諾します。これらのリソースに関して、他の目的で複製することや掲載することは禁止されています。TI や第三者の知的財産権のライセンスが付与されている訳ではありません。お客様は、これらのリソースを自身で使用した結果発生するあらゆる申し立て、損害、費用、損失、責任について、TI およびその代理人を完全に補償するものとし、TI は一切の責任を拒否します。

TI の製品は、[TI の販売条件](#)、または [ti.com](#) やかかる TI 製品の関連資料などのいずれかを通じて提供する適用可能な条項の下で提供されています。TI がこれらのリソースを提供することは、適用される TI の保証または他の保証の放棄の拡大や変更を意味するものではありません。

お客様がいかなる追加条項または代替条項を提案した場合でも、TI はそれらに異議を唱え、拒否します。

郵送先住所：Texas Instruments, Post Office Box 655303, Dallas, Texas 75265
Copyright © 2024, Texas Instruments Incorporated