

OPT4001-Q1 車載対応、高速、高精度、デジタル周辺光センサ

1 特長

- 車載アプリケーション用に AEC-Q100 認定済み:
 - 温度グレード 1 (PicoStar™ バリエント): -40°C ~ 125°C, T_A
 - 温度グレード 2 (USON バリエント): -40°C ~ 105°C, T_A
- 機能安全対応
 - 機能安全システムの設計に役立つ資料を利用可能
- 高速 I²C インターフェイスによる、高精度、高速な光 / デジタル変換
- 高精度の光フィルタリングは優れた近赤外線 (IR) 除去機能により人間の目とほぼ合致
- 片対数出力:
 - 9 つのバイナリ対数フルスケール光レンジ
 - 各範囲内で非常に線形的な応答
- 内蔵の自動フルスケール光レンジ選択ロジックにより、入力光条件に基づいて測定レンジを切り替え、常に可能な限り最高の分解能を実現
- 28 ビットでの実効ダイナミックレンジ:
 - PicoStar™ パッケージ バリエントで 312.5μlux ~ 83klux
 - USON パッケージ バリエントで 400μlux ~ 107klux
- 12 ステップの構成可能な変換時間:
 - 高速、高精度のアプリケーション向けに 600μs ~ 800ms
- ハードウェア同期トリガおよび割り込み用の外部ピン割り込み (USON パッケージバリエントのみ)
- エラー訂正コード機能を搭載しており、車載用途で信頼性を向上
- I²C バースト読み出し可能な出力レジスタ用内部 FIFO
- 小さい動作電流: 30μA
- 超低消費電力のスタンバイ: 2μA
- 広い電源電圧範囲: 1.6V ~ 3.6V
- 5.5V 許容の I/O ピン
- I²C アドレスを選択可能
- 小さい外形:
 - PicoStar™: 0.84mm x 1.05mm x 0.226mm
 - USON: 2mm x 2mm x 0.65mm

2 アプリケーション

- 車載用車内および車外照明
- インフォテインメントおよびクラスタ
- エレクトロクロマティック ミラーとスマート ミラー
- ワイパー モジュール
- ヘッドアップ ディスプレイ (HUD) システム
- 車載用カメラ システム

パッケージ情報

部品番号	パッケージ ⁽¹⁾	パッケージ サイズ ⁽³⁾
OPT4001-Q1	PicoStar™ (4) ⁽²⁾	0.84mm x 1.05mm x 0.226mm
	DNP (USON, 6)	2mm x 2mm x 0.65mm

- 詳細については、「メカニカル、パッケージ、および注文情報」を参照してください。
- 製品プレビュー。
- パッケージ サイズ (長さ×幅) は公称値であり、該当する場合はピッチも含まれます。

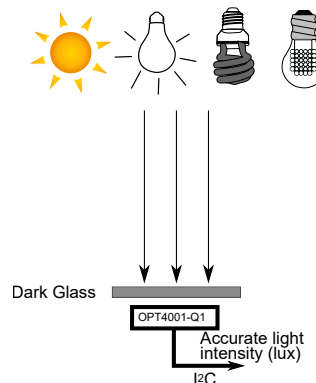

OPT4001-Q1 代表的なアプリケーションの図

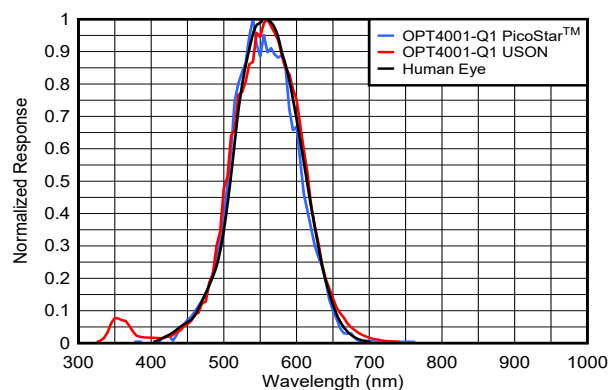

スペクトル応答: OPT4001-Q1 と人間の目の比較



3 概要

OPT4001-Q1 は、可視光の強度を測定する光 / デジタル センサ (シングル チップのルクス メーター) です。光の強度を正確に測定するために、本デバイスの特別に設計されたフィルタは、人間の目の明所視応答と厳密に一致し、一般的な光源からの近赤外線成分を除去します。OPT4001-Q1 の出力は、9 つのバイナリ対数フルスケール光レンジを持つ片対数であり、各レンジ内で非常に線形的な応答を実現しています。その結果、PicoStar™ バリエントで 312.5 μ lux ~ 83klux、USON バリエントで 400 μ lux ~ 107klux を測定できます。この機能により、この光センサは、28 ビットの実効ダイナミックレンジにわたって測定が可能です。内蔵の自動レンジ選択ロジックにより、光レベルに基づいてデバイスのゲイン設定が動的に調整されるため、ユーザーの入力なしであらゆる条件下で可能な限り最高の分解能が得られます。

OPT4001-Q1 の工学的光学フィルタは、強力な近赤外線 (NIR) 除去を実現しています。このフィルタは、審美的な理由でセンサを暗色のガラス下に配置した場合に、高い精度を維持するのに役立ちます。

OPT4001-Q1 は、ユーザーの使いやすさ向上のために光レベル検出機能を必要とするシステム向けに設計されており、通常、人間の目との一致度が低く近赤外線除去機能が劣る低精度のフォトダイオード、フォトレジスタ、その他の周辺光センサの代替品として利用できます。

OPT4001-Q1 デバイスは、12 ステップで 600 μ s ~ 800ms の光変換時間で動作するように設定でき、アプリケーションのニーズに応じたシステムの柔軟性を実現します。変換時間には、光の積分時間とアナログ / デジタル (ADC) 変換時間が含まれます。測定の分解能は光の強度と積分時間の組み合わせによって決まります。PicoStar™ バリエントでは実質的に 312.5 μ lux、USON バリエントでは 400 μ lux までの光の強度変化を測定できます。

柔軟なデジタル動作により、システムの統合が可能です。測定は連続的に行うことも、レジスタへの書き込みまたはハードウェアピン (ハードウェアピンは USON バリエントでのみ使用可能) を使用して 1 回の測定をトリガすることもできます。このデバイスにはスレッシュホールド検出ロジックが搭載されており、プロセッサはスリープ状態で、センサは適切なウェークアップイベントが割り込みピンで通知されるのを待機します (USON バリエントのみ)。

このセンサは、I²C および SMBus 互換の 2 線式シリアル インターフェイス上の光レベルを表すデジタル出力を報告します。出力レジスタの内部先入れ先出し (FIFO) を使用すると、センサからの測定値を低速で読み出すと同時に、デバイスでキャプチャされたすべてのデータを保持できます。また、OPT4001-Q1 は I²C バースト モードもサポートしており、ホストは最小限の I²C オーバーヘッドで FIFO からデータを読み取ることができます。

OPT4001-Q1 は、低い消費電力と低い電源電圧で動作するので、バッテリー駆動システムのバッテリー動作時間を延長できます。

Table of Contents

1 特長.....	1	7 Register Maps.....	26
2 アプリケーション.....	1	7.1 Register Descriptions	27
3 概要.....	2	8 Application and Implementation.....	36
4 Pin Configuration and Functions.....	3	8.1 Application Information.....	36
5 Specifications.....	5	8.2 Typical Application.....	36
5.1 Absolute Maximum Ratings.....	5	8.3 Best Design Practices.....	41
5.2 ESD Ratings.....	5	8.4 Power Supply Recommendations.....	41
5.3 Recommended Operating Conditions.....	5	8.5 Layout.....	42
5.4 Thermal Information.....	5	9 デバイスおよびドキュメントのサポート.....	47
5.5 Electrical Characteristics.....	6	9.1 ドキュメントのサポート.....	47
5.6 Timing Requirements.....	8	9.2 ドキュメントの更新通知を受け取る方法.....	47
5.7 Timing Diagram.....	8	9.3 サポート・リソース.....	47
5.8 Typical Characteristics.....	9	9.4 Trademarks.....	47
6 Detailed Description.....	11	9.5 静電気放電に関する注意事項.....	47
6.1 Overview.....	11	9.6 用語集.....	47
6.2 Functional Block Diagram.....	11	10 Revision History.....	47
6.3 Feature Description.....	12	11 Mechanical, Packaging, and Orderable Information.....	48
6.4 Device Functional Modes.....	14		
6.5 Programming.....	20		

4 Pin Configuration and Functions



図 4-1. YMN Package, 4-Pin PicoStar™
(Top View)

表 4-1. Pin Functions

PIN		TYPE ⁽¹⁾	DESCRIPTION
NO.	NAME		
A1	GND	P	Ground
B1	V _{DD}	I	Device power. Connect to a 1.6-V to 3.6-V supply.
A2	SCL	I	I ² C clock. Connect with a 10-kΩ resistor to a 1.6-V to 5.5-V supply.
B2	SDA	I/O	I ² C data. Connect with a 10-kΩ resistor to a 1.6-V to 5.5-V supply.

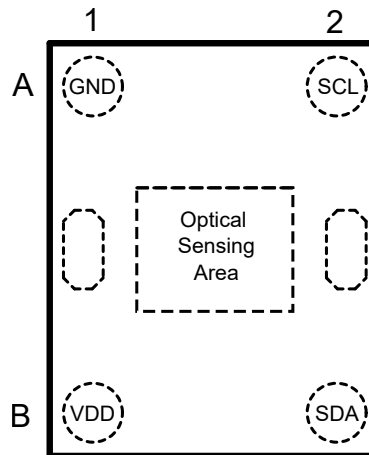
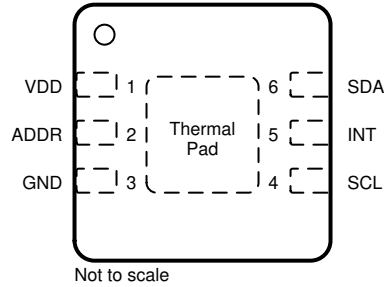

☒ 4-2. DNP Package, 6-Pin USON
(Top View)

表 4-2. Pin Functions

PIN		TYPE ⁽¹⁾	DESCRIPTION
NO.	NAME		
1	V _{DD}	I	Device power. Connect to a 1.6-V to 3.6-V supply.
2	ADDR	I	Address pin. This pin sets the LSBs of the I ² C address.
3	GND	P	Ground
4	SCL	I	I ² C clock. Connect with a 10-kΩ resistor to a 1.6-V to 5.5-V supply.
5	INT	I/O	Interrupt input/output open-drain. Connect with a 10-kΩ resistor to a 1.6-V to 5.5-V supply.
6	SDA	I/O	I ² C data. Connect with a 10-kΩ resistor to a 1.6-V to 5.5-V supply.

(1) I = Input, O = Output, I/O = Input or Output, P = Power

5 Specifications

5.1 Absolute Maximum Ratings

over operating free-air temperature range (unless otherwise noted)⁽¹⁾

		MIN	MAX	UNIT
	VDD to GND voltage	-0.5	6	V
	SDA and SCL to GND voltage	-0.5	6	V
	Current into any pin		10	mA
T _J	Junction temperature		150	°C
T _{stg}	Storage temperature	-65	150 ⁽²⁾	°C

- (1) Operation outside the Absolute Maximum Ratings may cause permanent device damage. Absolute Maximum Ratings do not imply functional operation of the device at these or any other conditions beyond those listed under Recommended Operating Conditions. If used outside the Recommended Operating Conditions but within the Absolute Maximum Ratings, the device may not be fully functional, and this may affect device reliability, functionality, performance, and shorten the device lifetime.
- (2) Long exposure to temperatures higher than 105°C can cause package discoloration, spectral distortion, and measurement inaccuracy.

5.2 ESD Ratings

			VALUE	UNIT
V _(ESD)	Electrostatic discharge	Human body model (HBM), per ANSI/ESDA/ JEDEC JS-001, all pins ⁽¹⁾	±2000	V
		Charged device model (CDM), per ANSI/ESDA/ JEDEC JS-002, all pins ⁽²⁾	±500	

- (1) JEDEC document JEP155 states that 500-V HBM allows safe manufacturing with a standard ESD control process.
- (2) JEDEC document JEP157 states that 250-V CDM allows safe manufacturing with a standard ESD control process.

5.3 Recommended Operating Conditions

over operating free-air temperature range (unless otherwise noted)

	MIN	NOM	MAX	UNIT
Supply voltage	1.6		3.6	V
Operating temperature (PicoStar™ variant)	-40		125	°C
Operating temperature (USON variant)	-40		105	

5.4 Thermal Information

THERMAL METRIC ⁽¹⁾		OPT4001-Q1		UNIT
		YMN (PicoStar™)	DNP (USON)	
		4 pins	6 Pins	
R _{θJA}	Junction-to-ambient thermal resistance	122.8	71.2	°C/W
R _{θJC(top)}	Junction-to-case (top) thermal resistance	1.4	45.7	°C/W
R _{θJB}	Junction-to-board thermal resistance	34.9	42.2	°C/W
Ψ _{JT}	Junction-to-top characterization parameter	0.8	2.4	°C/W
Ψ _{JB}	Junction-to-board characterization parameter	35.3	42.8	°C/W

- (1) For more information about traditional and new thermal metrics, see the [Semiconductor and IC Package Thermal Metrics](#) application note.

5.5 Electrical Characteristics

all specifications at $T_A = 25^\circ\text{C}$, $V_{DD} = 3.3\text{ V}$, 800-ms conversion time (CONVERSION_TIME = 0xB), automatic full-scale range, white LED, and normal-angle incidence of light (unless otherwise specified)

PARAMETER		TEST CONDITIONS	MIN	TYP	MAX	UNIT
OPTICAL						
PicoStar™ Variant						
	Peak irradiance spectral responsivity			540		nm
E_{VLSB}	Resolution	Lowest auto gain range, 800-ms conversion time		312.5		μlux
		Lowest auto gain range, 100-ms conversion time		2.5		mlux
E_{VFS}	Full-scale illuminance			83886		lux
	Angular response (FWHM)			96		$^\circ$
USON Variant						
	Peak irradiance spectral responsivity			550		nm
E_{VLSB}	Resolution	Lowest auto gain range, 800-ms conversion time		400		μlux
		Lowest auto gain range, 100-ms conversion time		3.2		mlux
E_{VFS}	Full-scale illuminance			107374		lux
	Angular response (FWHM)			120		$^\circ$
Common Specifications						
	Effective MANTISSA bits (register R_MSB and R_LSB)	Dependent on conversion time selected (register CT)	9		20	bits
	Exponent bits (register E)	Denotes the full-scale range		4		bits
E_v	Measurement output result	2000 lux input ⁽¹⁾	1800	2000	2200	lux
t_{conv}	Light conversion-time ⁽⁴⁾	Minimum selectable (CONVERSION_TIME = 0x0)		600		μs
		Maximum selectable (CONVERSION_TIME = 0xB)		800		ms
	Light source variation (incandescent, halogen, fluorescent)	Bare device, no cover glass		4		%
	Linearity	EXPONENT > 0, 100-ms conversion time CT=8		2		%
		EXPONENT = 0, 100-ms conversion time CT=8		5		
E_{VIR}	Infrared response	850-nm LED input		0.2		%
	Relative accuracy between gain ranges ⁽²⁾			0.4		%
	Drift across temperature	Visible light, input illuminance = 2000 lux		0.01		$\%/^\circ\text{C}$
	Dark measurement			0	10	mlux
PSRR	Power-supply rejection ratio ⁽³⁾	V_{DD} at 3.6 V and 1.6 V		0.1		$\%/V$
POWER SUPPLY						
V_{DD}	Power supply		1.6		3.6	V
V_{I2C}	Power supply for I ² C pullup resistor	I ² C pullup resistor, $V_{DD} \leq V_{I2C}$	1.6		5.5	V
$I_{QACTIVE}$	Active current	Dark		22		μA
		Full-scale lux		30		
I_Q	Quiescent current	Dark		1.6		μA
		Full-scale lux		2		
POR	Power-on-reset threshold			0.8		V

all specifications at $T_A = 25^\circ\text{C}$, $V_{DD} = 3.3\text{ V}$, 800-ms conversion time (CONVERSION_TIME = 0xB), automatic full-scale range, white LED, and normal-angle incidence of light (unless otherwise specified)

PARAMETER		TEST CONDITIONS	MIN	TYP	MAX	UNIT
DIGITAL						
C_{IO}	I/O pin capacitance			3		pF
t_{ss}	Trigger to sample start	Low-power shutdown mode		0.5		ms
V_{IL}	Low-level input voltage (SDA, SCL, and ADDR)		0		$0.3 \times V_{DD}$	V
V_{IH}	High-level input voltage (SDA, SCL, and ADDR)		$0.7 \times V_{DD}$		5.5	V
I_{IL}	Low-level input current (SDA, SCL, and ADDR)			0.01	0.25 ⁽⁵⁾	μA
V_{OL}	Low-level output voltage (SDA and INT)	$I_{OL} = 3\text{ mA}$			0.32	V
I_{ZH}	Output logic high, high-Z leakage current (SDA, INT)	Measured with V_{DD} at pin		0.01	0.25 ⁽⁵⁾	μA
TEMPERATURE						
Specified temperature range		PicoStar™ variant	-40		125	°C
		USON variant	-40		105	

- (1) Tested with the white LED calibrated to 2000 lux.
- (2) Characterized by measuring fixed near-full-scale light levels on the higher adjacent full-scale range setting.
- (3) PSRR is the percent change of the measured lux output from the current value, divided by the change in power supply voltage, as characterized by results from 3.6-V and 1.6-V power supplies.
- (4) The conversion time, from start of conversion until the data are ready to be read, is the integration time plus the analog-to-digital conversion time.
- (5) The specified leakage current is dominated by the production test equipment limitations. Typical values are much smaller.

5.6 Timing Requirements

see (1)

		MIN	TYP	MAX	UNIT
I²C FAST MODE					
f_{SCL}	SCL operating frequency	0.01		0.4	MHz
t_{BUF}	Bus free time between stop and start	1300			ns
t_{HDSTA}	Hold time after repeated start	600			ns
t_{SUSTA}	Setup time for repeated start	600			ns
t_{SUSTO}	Setup time for stop	600			ns
t_{HDDAT}	Data hold time	20		900	ns
t_{SUDAT}	Data setup time	100			ns
t_{LOW}	SCL clock low period	1300			ns
t_{HIGH}	SCL clock high period	600			ns
t_{RC} and t_{FC}	Clock rise and fall time			300	ns
t_{RD} and t_{FD}	Data rise and fall time			300	ns
t_{TIMEO}	Bus timeout period. If the SCL line is held low for this duration of time, the bus state machine is reset.		28		ms
I²C HIGH-SPEED MODE					
f_{SCL}	SCL operating frequency	0.01		2.6	MHz
t_{BUF}	Bus free time between stop and start	160			ns
t_{HDSTA}	Hold time after repeated start	160			ns
t_{SUSTA}	Setup time for repeated start	160			ns
t_{SUSTO}	Setup time for stop	160			ns
t_{HDDAT}	Data hold time	20		140	ns
t_{SUDAT}	Data setup time	20			ns
t_{LOW}	SCL clock low period	240			ns
t_{HIGH}	SCL clock high period	60			ns
t_{RC} and t_{FC}	Clock rise and fall time			40	ns
t_{RD} and t_{FD}	Data rise and fall time			80	ns
t_{TIMEO}	Bus timeout period. If the SCL line is held low for this duration of time, the bus state machine is reset.		28		ms

(1) All timing parameters are referenced to low and high voltage thresholds of 30% and 70%, respectively, of the final settled value.

5.7 Timing Diagram



图 5-1. I²C Detailed Timing Diagram

5.8 Typical Characteristics

at $T_A = 25^\circ\text{C}$, $V_{DD} = 3.3\text{ V}$, 800-ms conversion time (CONVERSION_TIME = 0xB), automatic full-scale range (RANGE = 0xC), white LED, and normal-angle incidence of light (unless otherwise noted)

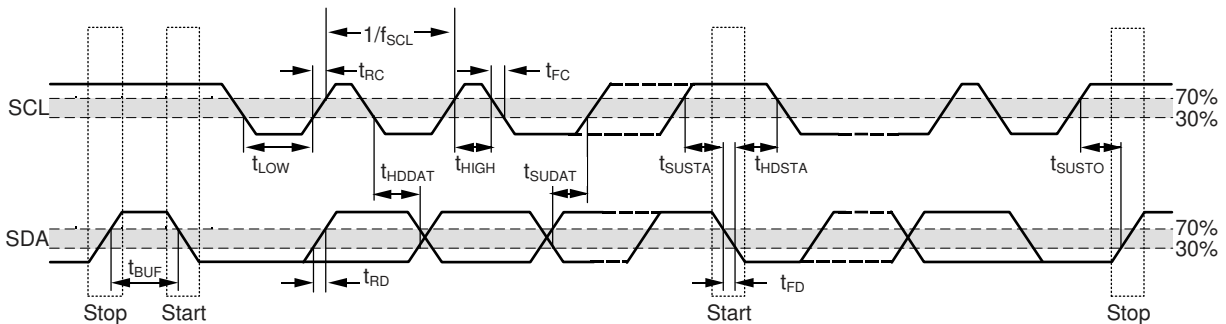

图 5-2. Spectral Response vs Wavelength



Normalized to 0°

图 5-3. Device Response vs Illuminance Angle

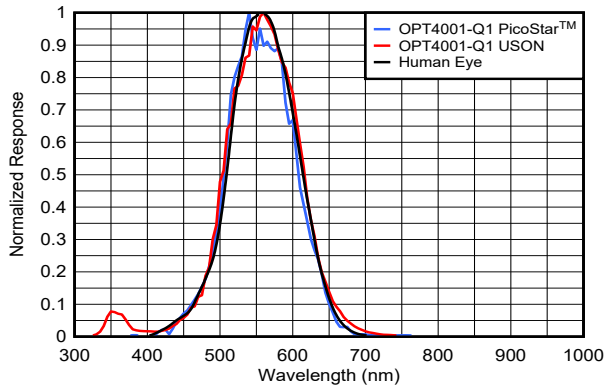
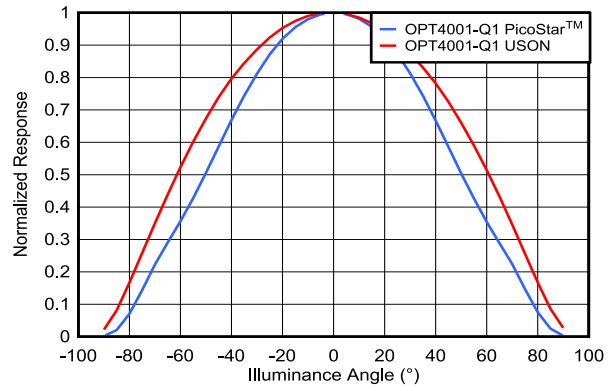
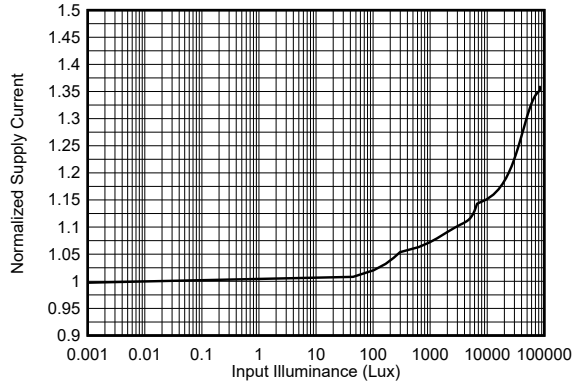

Normalized to dark condition

图 5-4. Active Current vs Input Light Level

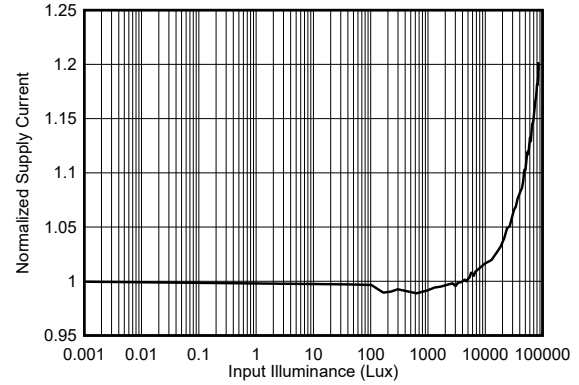

Normalized to dark condition

图 5-5. Standby Current vs Input Light Level

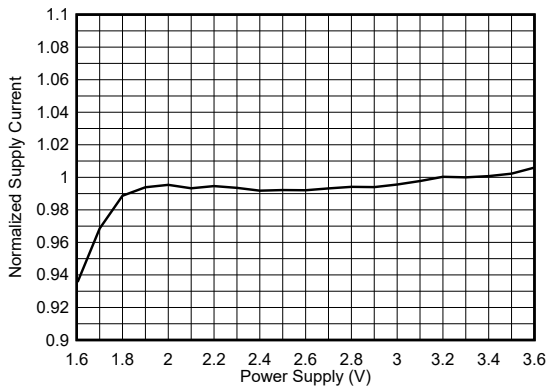

Normalized to 3.3 V

图 5-6. Active Current vs Power Supply

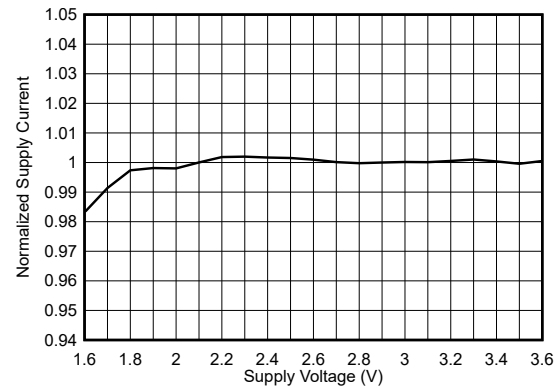

Normalized to 3.3 V

图 5-7. Standby Current vs Power Supply

5.8 Typical Characteristics (continued)

at $T_A = 25^\circ\text{C}$, $V_{DD} = 3.3\text{ V}$, 800-ms conversion time (CONVERSION_TIME = 0xB), automatic full-scale range (RANGE = 0xC), white LED, and normal-angle incidence of light (unless otherwise noted)

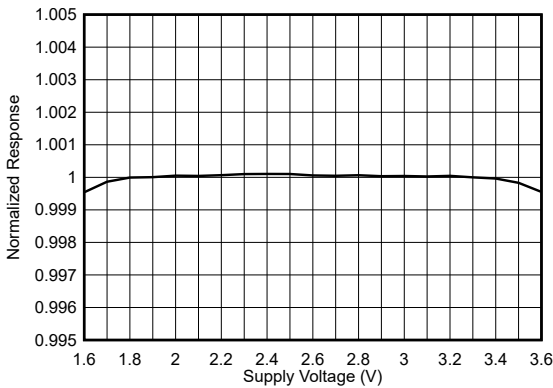

Normalized to 3.3 V

5-8. Device Response vs Power Supply

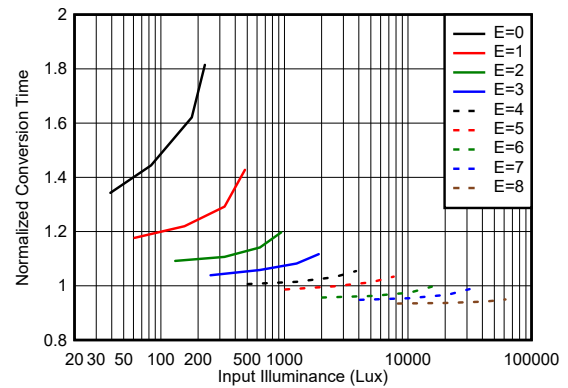

Register E (exponent) denotes the full-scale range
Normalized to 600 μs

5-9. Conversion Time at 600 μs vs Input Light Level

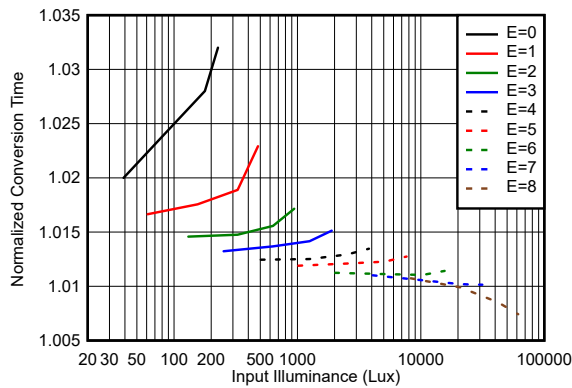

Register E (exponent) denotes the full-scale range
Normalized to 25 ms

5-10. Conversion Time at 25 ms vs Input Light Level

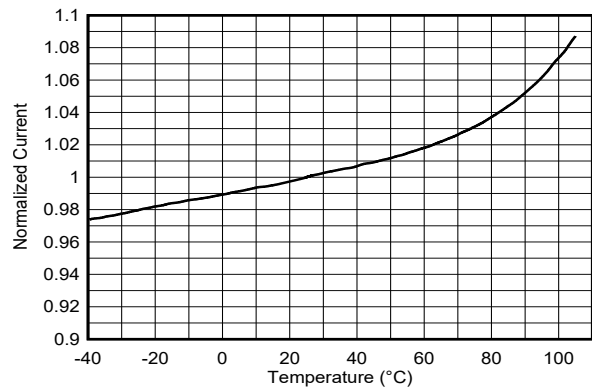

Normalized to 25°C

5-11. Active Current vs Temperature

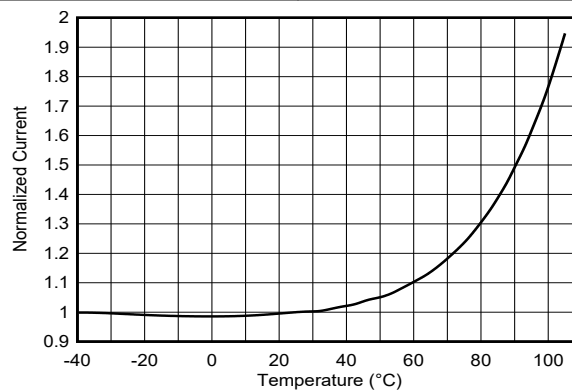

Normalized to 25°C

5-12. Standby Current vs Temperature

6 Detailed Description

6.1 Overview

The OPT4001-Q1 measures the ambient light that illuminates the device. This device measures light with a spectral response very closely matched to the human eye, and with strong near-infrared rejection.

Matching the sensor spectral response to that of the human eye response is vital because ambient light sensors measure and help create human lighting experiences. Strong rejection of infrared light, which a human does not see, is a crucial component of this matching. This matching makes the OPT4001-Q1 especially good for operation underneath windows that are visibly dark, but infrared transmissive.

The OPT4001-Q1 is fully self-contained to measure the ambient light and report the result in ADC codes directly proportional to lux digitally over the I²C bus. The result can also be used to alert a system and interrupt a processor with the INT pin (with the USON package variant). The result can also be summarized with a programmable threshold comparison and communicated with the INT pin (with the USON package variant).

The OPT4001-Q1 is by default configured to operate in automatic, full-scale range detection mode that always selects the best full-scale range setting for the given lighting conditions. There are nine full-scale range settings, one of which can be selected manually as well. Setting the device to operate in automatic, full-scale-range detection mode frees the user from programming software for multiple iterations of measurement and readjustment of the full-scale range until reaching acceptable results for any given measurement. With the device exhibiting excellent linearity over the entire 28-bit dynamic range of measurement, no additional linearity calibration is required at the system level.

The OPT4001-Q1 can be configured to operate in continuous or one-shot measurement mode. The device offers 12 conversion times ranging from 600 μ s to 800 ms. The device starts up in a low-power shutdown state, such that the OPT4001-Q1 only consumes active-operation power when the device is programmed into an active state.

The OPT4001-Q1 optical filtering system is not excessively sensitive to small particles and micro-shadows on the optical surface. This reduced sensitivity is a result of the relatively minor device dependency on uniform density optical illumination of the sensor area for infrared rejection. Always follow proper optical surface cleanliness for best results on all optical devices.

6.2 Functional Block Diagram



图 6-1. Functional Block Diagram of the OPT4001-Q1

6.3 Feature Description

6.3.1 Spectral Matching to Human Eye

The OPT4001-Q1 spectral response closely matches that of the human eye. If the ambient light sensor measurement is used to help create a good human experience, or create optical conditions that are good for humans, then the sensor must measure the same spectrum of light that a human sees.

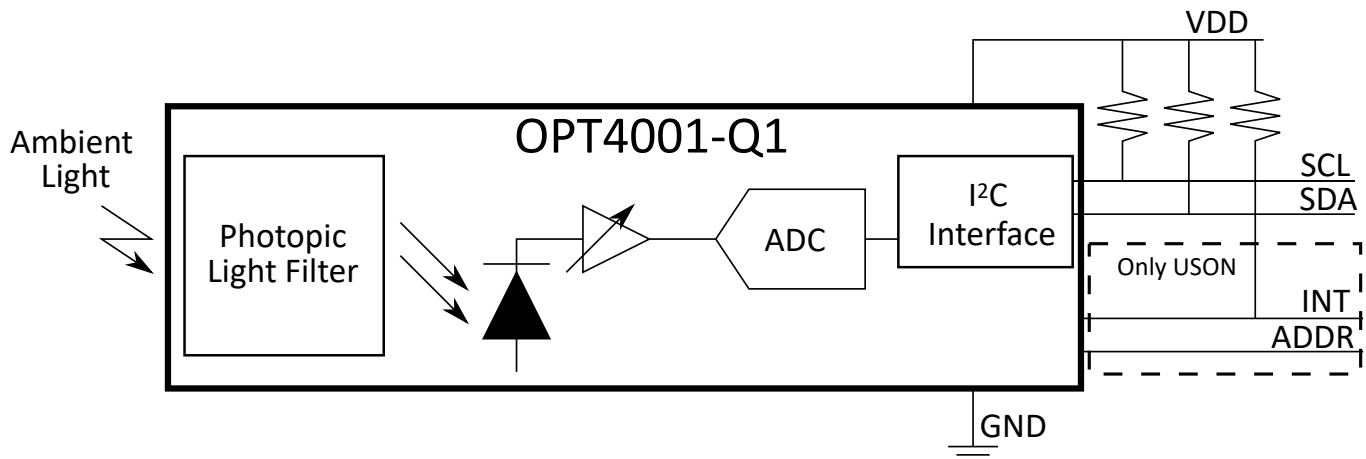
The OPT4001-Q1 also has excellent near-infrared light (NIR) rejection. This NIR rejection is especially important because many real-world lighting sources have significant infrared content that humans do not see. If the sensor measures infrared light that the human eye does not see, then a true human experience is not accurately represented.

If the application demands hiding the OPT4001-Q1 underneath a dark window (such that the end-product user cannot see the sensor), the infrared rejection of the OPT4001-Q1 becomes significantly more important because many dark windows attenuate visible light but transmit infrared light. This attenuation of visible light and lack of attenuation of NIR light amplifies the ratio of the infrared light to visible light that illuminates the sensor. Results can still be well matched to the human eye under this condition because of the high infrared rejection of the OPT4001-Q1.

6.3.2 Automatic Full-Scale Range Setting

The OPT4001-Q1 has an automatic full-scale range setting feature that eliminates the need to predict and set the best range for the device. In this mode, the device automatically selects the best full-scale range for varying lighting conditions for each measurement. The device has a high degree of result matching between the full-scale range settings. This matching eliminates the problem of varying results or the need for range-specific, user-calibrated gain factors when different full-scale ranges are chosen.

6.3.3 Error Correction Code (ECC) Features

The OPT4001-Q1 features additional error correction code (ECC) bits as part of the output register that helps improve the reliability of light measurements for the application.

6.3.3.1 Output Sample Counter

The OPT4001-Q1 features a **COUNTER** register as part of the output registers that increment for every successful measurement. This register can be read as part of the output registers, which helps the application keep track of measurements. The 4-bit counter starts at 0 on power-up and counts up to 15, after that the counter resets back to 0 and continues to count up, which is particularly helpful in situations such as the following:

- The host or the controller requires consecutive measurements. Using the **COUNTER** register allows the controller to compare samples and makes sure that the samples are in the expected order without missing intermediate counter values.
- As a safety feature when light levels are not changing, the controller can make sure that the measurements from the OPT4001-Q1 are not stuck by comparing the values of the **COUNTER** register between measurements. If the **COUNTER** values continue to change over samples, the device updates the output register with the most recent measurement of light levels.

6.3.3.2 Output CRC

The CRC register consists of cyclic redundancy checker bits as part of the output registers calculated within the OPT4001-Q1 and is updated on every measurement. This feature helps detect communication-related bit errors during the output readout from the device. Register 1 lists the calculation method for the CRC bits, which can be independently verified in the controller or host firmware and software to validate if communication between the controller and the device was successful without bit errors during transmission.

6.3.4 Output Register FIFO

Output registers always contain the most recent light measurement. Along with the output registers, there are three more shadow registers that have data from the previous three measurements. For every new measurement, the data on the three shadow registers are updated to contain the most recent measurements, discarding the oldest measurement similar to a FIFO scheme. These shadow registers, along with the output registers, act like a FIFO with a depth of 4. The INT pin can be configured (as shown in Figure 6-2) to generate an interrupt for every measurement, or can be configured to generate an interrupt every four measurements using the INT_CFG register. In this manner, the controller reading data from the OPT4001-Q1 minimizes the number of interrupts by a factor of 4 and is still provided access to all four measurements between the interrupts. By using burst read mode, the output and FIFO registers can be read out with minimal I²C clocks.

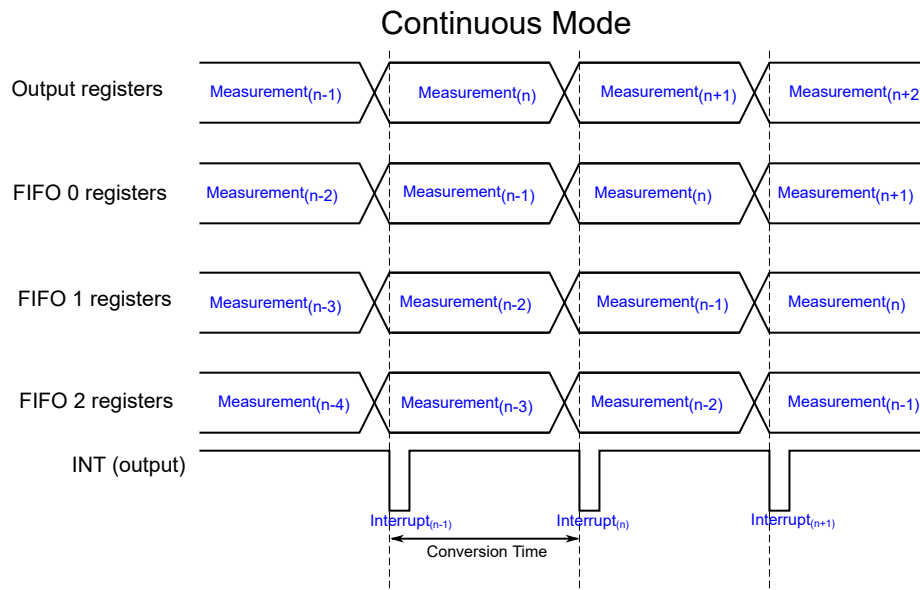

Figure 6-2. FIFO Registers Data Movement

6.3.5 Threshold Detection

The OPT4001-Q1 features a threshold detection logic that can be programmed to indicate and update register flags if measured light levels cross thresholds set by the user. There are independent low- and high-threshold target registers with independent flag registers to indicate the status of measured light level. Measured light levels reaching below the low threshold and above the high threshold are called *faults*. Users can program a fault count register, which counts the consecutive number of faults before the flag registers are set. This feature is particularly useful in cases where the controller reads the flag register alone to get an indication of the measured light level without having to perform the lux calculations. Calculations for setting up the threshold are available in the [Threshold Detection Calculations](#) section.

6.4 Device Functional Modes

6.4.1 Modes of Operation

The OPT4001-Q1 has the following modes of operation:

- **Power-down mode:** This mode is a power-down or standby mode where the device enters a low-power state. There is no active light sensing or conversion in this mode. The device still responds to I²C transactions that can be used to bring the device out of this mode. The [OPERATING_MODE](#) register is set to 0.
- **Continuous mode:** In this mode, the OPT4001-Q1 measures and updates the output registers continuously as determined by the conversion time and generates a hardware interrupt on the INT pin (only on USON package variant) for every successful conversion. Configure the INT pin in output mode using the [INT_DIR](#) register. The device active circuits are continuously kept active to minimize the interval between measurements. The [OPERATING_MODE](#) register is set to 3.
- **One-shot mode:** There are two ways in which the OPT4001-Q1 can be used in one-shot mode of operation with one common theme where the OPT4001-Q1 stays in standby mode and a conversion is triggered either by a register write to the configuration register or by a hardware interrupt on the INT pin.

There are two types of one-shot modes. Both of these modes operate with auto-range selection logic unless a manual range mode is specified by setting the RANGE bits in the configuration register.

- **Force auto-range one-shot mode:** Every one-shot trigger forces a full reset on the auto-ranging control logic and a fresh auto-range detection is initiated, ignoring the previous measurements. This mode is particularly useful in situations where lighting conditions are expected to change frequently and the conditions for the one-shot trigger frequency are not expected to change very often. There is a small penalty on conversion time resulting from the auto-ranging logic recovering from a reset state. The full reset cycle on the auto-ranging control logic takes approximately 500 μs, which must be accounted for between measurements when this mode is used. The [OPERATING_MODE](#) register is set to 1.
- **Regular auto-range one-shot mode:** Auto-range selection logic uses the information from the previous measurements to determine the range for the current trigger. Only use this mode when the device needs time-synchronized measurements with frequent triggers from the controller. In other words, this mode can be used as an alternative to continuous mode. The key difference between these modes is that the interval between measurements is determined by the one-shot triggers. The [OPERATING_MODE](#) register is set to 2.

One-shot mode can be triggered by the following:

- **Hardware trigger (only on USON package variant):** The INT pin can be configured as an input to trigger a measurement, setting the [INT_DIR](#) register to 0. When the INT pin is used as input, there is no hardware interrupt to indicate completion of measurement. The controller must keep time from the trigger mechanism and read out output registers.
- **Register trigger:** An I²C write to the [OPERATING_MODE](#) register triggers a measurement (value of 1 or 2). The register value is reset after the next successful measurement. The INT pin can be configured to indicate measurement completion to read out the output registers by setting the [INT_DIR](#) register to 1.

The interval between subsequent triggers must be set to account for all aspects involved in the trigger mechanism, such as the I²C transaction time, device wake-up time, auto-range time (if used), and device conversion time. If a conversion trigger is received before the completion of the current measurement, the device simply ignores the new request until the previous conversion is completed.

The device enters standby after each one-shot trigger; therefore, the measurement interval in the one-shot trigger mechanism must account for additional time (t_{ss} time, as specified in the [Specifications](#) section for the circuits to recover from standby state. However, setting the quick wake-up register [QWAKE](#) eliminates the need for this additional t_{ss} at the cost of not powering down the active circuit with the device not entering standby mode between triggers.

☒ [6-3](#) illustrates a timing diagram of the various operating modes.



図 6-3. Timing Diagrams for Different Operating Modes

6.4.2 Interrupt Modes of Operation

The device has an interrupt reporting system that allows the processor connected to the I²C bus to go to sleep, or otherwise ignore the device results, until a user-defined event occurs that requires possible action. Alternatively, this same mechanism can also be used with any system that can take advantage of a single digital signal that indicates whether the light is above or below levels of interest.

The INT pin (only available on USON variant) has an open-drain output, which requires the use of a pullup resistor. This open-drain output allows multiple devices with open-drain INT pins to connect to the same line, thus creating a logical *NOR* or *AND* function between the devices. The polarity of the INT pin can be controlled by the `INT_POL` register.

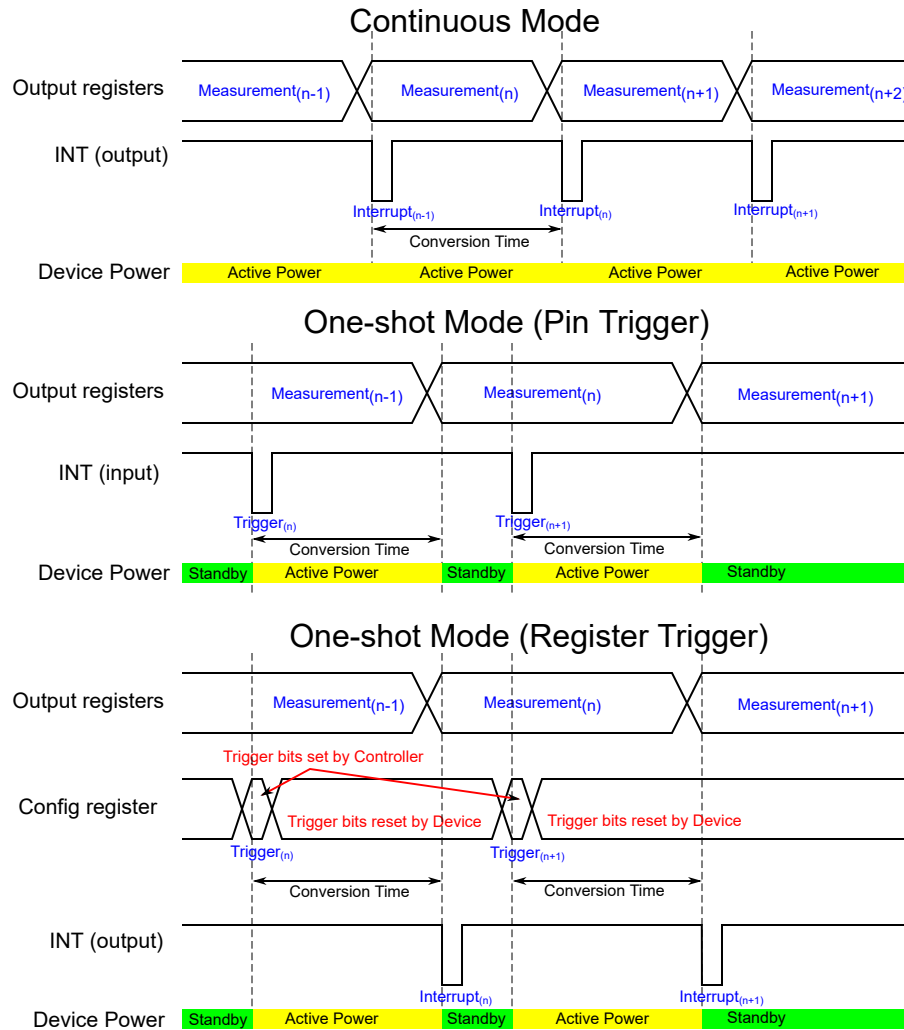
There are two major types of interrupt reporting mechanism modes: latched window comparison mode and transparent hysteresis comparison mode. The `LATCH` configuration register controls which of these two modes is used. 表 6-1 and 図 6-4 summarize the function of these two modes. Additionally, the INT pin can either be used to indicate a fault in one of these modes (`INT_CFG = 0`) or to indicate a conversion completion (`INT_CFG > 0`). 表 6-2 details this functionality.



図 6-4. Interrupt Pin Status (INT_CFG = 0 Setting) and Register Flag Behavior

表 6-1. Interrupt Pin Status (INT_CFG = 0 Setting) and Register Flag Behavior

LATCH SETTING	INT PIN STATE (WHEN INT_CFG=0)	FLAG_H VALUE	FLAG_L VALUE	LATCHING BEHAVIOR
0: Transparent hysteresis mode	The INT pin indicates if measurement is above (INT active) or below (INT inactive) the threshold. If measurement is between the high and low threshold values, then the previous INT value is maintained. This mode prevents the INT pin from repeated toggling when the measurement values are close to the threshold.	0: If measurement is below the low limit 1: If measurement is above the high limit If measurement is between the high and low limits, the previous value is maintained.	0: If measurement is above the high limit 1: If measurement is below the low limit If measurement is between the high and low limits, the previous value is maintained.	Not latching: Values are updated after each conversion
1: Latched window mode	The INT pin becomes active if the measurement is outside the window (above the high threshold or below the low threshold). The INT pin does not reset and returns to the inactive state until the 0xC is register read.	1: If measurement is above the high limit	1: If measurement is below the low limit	Latching: The INT pin, FLAG_H, and FLAG_L values do not reset until the 0x0C register is read.

The [THRESHOLD_H](#), [THRESHOLD_L](#), [LATCH](#), and [FAULT_COUNT](#) registers control the interrupt behavior. As shown in [表 6-1](#), the [LATCH](#) field setting provides a choice between the latched window mode and transparent hysteresis mode. Interrupt reporting can be observed on the INT pin (for USON variant only), the [FLAG_H](#), and the [FLAG_L](#) registers.

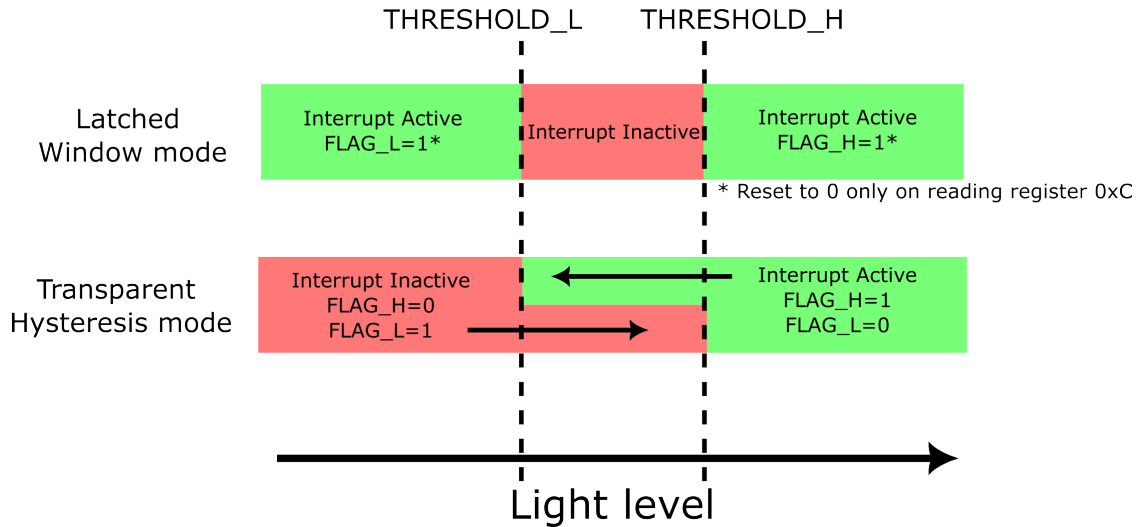
Results from comparing the current sensor measurements with the [THRESHOLD_H](#) and [THRESHOLD_L](#) registers are referred to as *fault events*. See the [Threshold Detection Calculations](#) section for the calculations to set these registers. The [FAULT_COUNT](#) register dictates the number of continuous *fault events* required to trigger an interrupt event and subsequently change the state of the interrupt reporting mechanisms. For example, with a [FAULT_COUNT](#) value of 2 corresponding to four fault counts, the INT pin (USON variant only), [FLAG_H](#), and [FLAG_L](#) states shown in [表 6-1](#) are not realized unless four consecutive measurements are taken that satisfy the fault condition.

The INT pin function (for USON variant only) listed in 表 6-1 is valid only when INT_CFG = 0. As described in 表 6-2, the INT pin function can be changed to indicate an end of conversion or FIFO full state. The FLAG_H and FLAG_L registers continue to behave as listed in 表 6-1, even while INT_CFG > 0. The polarity of the INT pin is controlled by the INT_POL register.

表 6-2. INT_CFG Setting and Resulting INT Pin Behavior

INT_CFG SETTING	INT PIN FUNCTION
0	As per 表 6-1
1	INT pin asserted with a 1- μ s pulse duration after every conversion
3	INT pin asserted with a 1- μ s pulse duration every four conversions to indicate the FIFO is full

6.4.3 Light Range Selection

The OPT4001-Q1 has an automatic full-scale-range setting mode that eliminates the need to predict and set the best range for the device. Set the RANGE register to 0xC to enter this mode. The device determines the appropriate full-scale range to take the measurement based on a combination of current lighting conditions and the previous measurement.

If a measurement is towards the low side of full-scale, then the full-scale range is decreased by one or two settings for the next measurement. If a measurement is towards the upper side of full-scale, the full-scale range is increased by one setting for the next measurement.

If the measurement exceeds the full-scale range, resulting from a fast increasing optical transient event, then the current measurement is terminated. This invalid measurement is not reported. If the scale is not at the maximum, then the device increases the scale by one step and a new measurement is retaken with that scale. Therefore, during a fast increasing optical transient in this mode, a measurement can possibly take longer to complete and report than indicated by the CONVERSION_TIME configuration register.

Using this feature is highly recommended by Texas Instruments because the device selects the best range setting based on lighting conditions. However, there is an option to manually set the range. Setting the range manually turns off the automatic full-scale selection logic and the device operates for a particular range setting. 表 6-3 lists the range selection settings.

表 6-3. Range Selection Table

RANGE REGISTER SETTING	TYPICAL FULL-SCALE LIGHT LEVEL FOR PICOSTAR™ VARIANT	TYPICAL FULL-SCALE LIGHT LEVEL FOR USON VARIANT
0	328 lux	419 lux
1	655 lux	839 lux
2	1311 lux	1678 lux
3	2621 lux	3355 lux
4	5243 lux	6711 lux
5	10486 lux	13422 lux
6	20972 lux	26844 lux
7	41943 lux	53687 lux
8	83886 lux	107374 lux
12	Determined by automatic full-scale range logic	

6.4.4 Selecting Conversion Time

As listed in 表 6-4, the OPT4001-Q1 offers several conversion times that can be selected. Conversion time is defined as the time taken from initiation to completion of one measurement, including the time taken to update the results in the output register. Measurement initiation is determined by the mode of operation, as specified in [Modes of Operation](#) section.

表 6-4. Conversion Time Selection

CONVERSION_TIME REGISTER	TYPICAL CONVERSION TIME
0	0.6 ms
1	1 ms
2	1.8 ms
3	3.4 ms
4	6.5 ms
5	12.7 ms
6	25 ms
7	50 ms
8	100 ms
9	200 ms
10	400 ms
11	800 ms

6.4.5 Light Measurement in Lux

The OPT4001-Q1 measures light and updates output registers with proportional ADC codes. The output of the device is represented by two parts: by four **EXPONENT** register bits and by 20 **MANTISSA** bits. This arrangement of binary logarithmic full-scale ranges with linear representation in a range helps cover a large dynamic range of measurements. **MANTISSA** represents the linear ADC codes proportional to the measured light within a given full-scale range and the **EXPONENT** bits represent the current full-scale range selected. The selected range can either be automatically determined by the auto-range selection logic or manually selected as per 表 6-3.

The lux level can be determined using the following equations. First, use 式 1 or 式 2 to calculate the **MANTISSA**. Next, use 式 3 or 式 4 to calculate the **ADC_CODES**. Finally, use 式 6 to calculate the lux.

$$\text{MANTISSA} = (\text{RESULT_MSB} \ll 8) + \text{RESULT_LSB} \quad (1)$$

or

$$\text{MANTISSA} = (\text{RESULT_MSB} \times 2^8) + \text{RESULT_LSB} \quad (2)$$

where:

- The **RESULT_MSB**, **RESULT_LSB**, and **EXPONENT** bits are parts of the output register

The **RESULT_MSB** register carries the most significant 12 bits of the **MANTISSA**, and the **RESULT_LSB** register carries the least significant eight bits of the **MANTISSA**. Use the previous equations to get the 20-bit **MANTISSA** number. The four **EXPONENT** bits are directly read from the register.

After the **EXPONENT** and **MANTISSA** portions are calculated, use 式 3 or 式 4 to calculate the linearized **ADC_CODES**.

$$\text{ADC_CODES} = (\text{MANTISSA} \ll E) \quad (3)$$

or

$$\text{ADC_CODES} = (\text{MANTISSA} \times 2^E) \tag{4}$$

The maximum value for register E is 8, thus the ADC_CODES is effectively a 28-bit number. As shown in 式 6, the semi-logarithmic numbers are converted to a linear ADC_CODES representation, which is simple to convert to lux.

$$\text{lux} = \text{ADC_CODES} \times 312.5\text{E-}6 \text{ for the PicoStar™ variant} \tag{5}$$

$$\text{lux} = \text{ADC_CODES} \times 400\text{E-}6 \text{ for the USON variant} \tag{6}$$

The MANTISSA and ADC_CODES are large numbers with 20 and 28 bits required to represent them. While developing firmware or software for these calculations, allocating appropriate data types to prevent data overflow is important. Some explicit typecasting to a larger data type is recommended, such as 32-bit representation before a left-shift operation (<<).

6.4.6 Threshold Detection Calculations

The THRESHOLD_H_RESULT and THRESHOLD_L_RESULT threshold result registers are 12 bits, whereas the THRESHOLD_H_EXPONENT and THRESHOLD_L_EXPONENT threshold exponent registers are four bits. The threshold is compared at linear ADC_CODES, as given by the following equations. Therefore, the threshold registers are padded with zeros internally to compare with the ADC_CODES.

$$\text{ADC_CODES_TH} = \text{THRESHOLD_H_RESULT} \ll (8 + \text{THRESHOLD_H_EXPONENT}) \tag{7}$$

or

$$\text{ADC_CODES_TH} = \text{THRESHOLD_H_RESULT} \times 2^{(8 + \text{THRESHOLD_H_EXPONENT})} \tag{8}$$

and

$$\text{ADC_CODES_TL} = \text{THRESHOLD_L_RESULT} \ll (8 + \text{THRESHOLD_L_EXPONENT}) \tag{9}$$

or

$$\text{ADC_CODES_TL} = \text{THRESHOLD_L_RESULT} \times 2^{(8 + \text{THRESHOLD_L_EXPONENT})} \tag{10}$$

Thresholds are then compared as given in the following equations to detect *fault events*.

$$\text{If } \text{ADC_CODES} < \text{ADC_CODES_TL} \text{ a } \textit{fault low} \text{ is detected} \tag{11}$$

and

$$\text{If } \text{ADC_CODES} > \text{ADC_CODES_TH} \text{ a } \textit{fault high} \text{ is detected} \tag{12}$$

Based on the FAULT_COUNT register setting, with consecutive *fault high* or *fault low* events, the respective FLAG_H and FLAG_L registers are set. See the *Interrupt Modes of Operation* section for more information. Understanding the relation between the THRESHOLD_H_EXPONENT, THRESHOLD_H_RESULT, THRESHOLD_L_EXPONENT, and THRESHOLD_L_RESULT register bits and the output registers is important to set the appropriate threshold based on application needs.

6.4.7 Light Resolution

The effective resolution of the OPT4001-Q1 is dependent on both the conversion time setting and the full-scale light range. Although the LSB resolution of the linear ADC_CODES does not change, the effective or useful

resolution of the device is dependent (as per 表 6-6) on the conversion time setting and the full-scale range. In conversion times where the effective resolution is lower, the LSBs are padded with 0.

表 6-5. Resolution Table for the PicoStar™ Variant

CONVERSION TIME REGISTER	CONVERSION TIME	MANTISSA EFFECTIVE BITS	EXPONENT								
			0	1	2	3	4	5	6	7	8
			FULL-SCALE LUX (Effective Resolution in Lux)								
			328	655	1310	2621	5243	10486	20972	41943	83886
0	600 μs	9	640 m	1.28	2.56	5.12	10.24	20.48	40.96	81.82	163.84
1	1 ms	10	320 m	640 m	1.28	2.56	5.12	10.24	20.48	40.96	81.82
2	1.8 ms	11	160 m	320 m	640 m	1.28	2.56	5.12	10.24	20.48	40.96
3	3.4 ms	12	80 m	160 m	320 m	640 m	1.28	2.56	5.12	10.24	20.48
4	6.5 ms	13	40 m	80 m	160 m	320 m	640 m	1.28	2.56	5.12	10.24
5	12.7 ms	14	20 m	40 m	80 m	160 m	320 m	640 m	1.28	2.56	5.12
6	25 ms	15	10 m	20 m	40 m	80 m	160 m	320 m	640 m	1.28	2.56
7	50 ms	16	5 m	10 m	20 m	40 m	80 m	160 m	320 m	640 m	1.28
8	100 ms	17	2.5 m	5 m	10 m	20 m	40 m	80 m	160 m	320 m	640 m
9	200 ms	18	1.25 m	2.5 m	5 m	10 m	20 m	40 m	80 m	160 m	320 m
10	400 ms	19	0.625 m	1.25 m	2.5 m	5 m	10 m	20 m	40 m	80 m	160 m
11	800 ms	20	0.3125 m	0.625 m	1.25 m	2.5 m	5 m	10 m	20 m	40 m	80 m

表 6-6. Resolution Table for the USON Variant

CONVERSION TIME REGISTER	CONVERSION TIME	MANTISSA EFFECTIVE BITS	EXPONENT								
			0	1	2	3	4	5	6	7	8
			FULL-SCALE LUX (Effective Resolution in Lux)								
			419	839	1678	3355	6711	13422	26844	53687	107374
0	600 μs	9	819.2 m	1.64	3.28	6.55	13.11	26.21	52.43	104.86	209.72
1	1 ms	10	409.6 m	819.2 m	1.64	3.28	6.55	13.11	26.21	52.43	104.86
2	1.8 ms	11	204.8 m	409.6 m	819.2 m	1.64	3.28	6.55	13.11	26.21	52.43
3	3.4 ms	12	102.4 m	204.8 m	409.6 m	819.2 m	1.64	3.28	6.55	13.11	26.21
4	6.5 ms	13	51.2 m	102.4 m	204.8 m	409.6 m	819.2 m	1.64	3.28	6.55	13.11
5	12.7 ms	14	25.6 m	51.2 m	102.4 m	204.8 m	409.6 m	819.2 m	1.64	3.28	6.55
6	25 ms	15	12.8 m	25.6 m	51.2 m	102.4 m	204.8 m	409.6 m	819.2 m	1.64	3.28
7	50 ms	16	6.4 m	12.8 m	25.6 m	51.2 m	102.4 m	204.8 m	409.6 m	819.2 m	1.64
8	100 ms	17	3.2 m	6.4 m	12.8 m	25.6 m	51.2 m	102.4 m	204.8 m	409.6 m	819.2 m
9	200 ms	18	1.6 m	3.2 m	6.4 m	12.8 m	25.6 m	51.2 m	102.4 m	204.8 m	409.6 m
10	400 ms	19	0.8 m	1.6 m	3.2 m	6.4 m	12.8 m	25.6 m	51.2 m	102.4 m	204.8 m
11	800 ms	20	0.4 m	0.8 m	1.6 m	3.2 m	6.4 m	12.8 m	25.6 m	51.2 m	102.4 m

6.5 Programming

The OPT4001-Q1 supports the transmission protocol for standard LUX mode (up to 100 kHz), fast mode (up to 400 kHz), and high-speed mode (up to 2.6 MHz). Fast and standard modes are described as the default protocol, referred to as *F/S*. High-speed mode is described in the [High-Speed I2C Mode](#) section.

6.5.1 I²C Bus Overview

The OPT4001-Q1 offers compatibility with both I²C and SMBus interfaces. The I²C and SMBus protocols are essentially compatible with one another. The I²C interface is used throughout this document as the primary example with the SMBus protocol specified only when a difference between the two protocols is discussed.

The device is connected to the bus with two pins: an SCL clock input pin and an SDA open-drain bidirectional data pin. The bus must have a controller device that generates the serial clock (SCL), controls the bus access, and generates start and stop conditions. To address a specific device, the controller initiates a start condition by pulling the data signal line (SDA) from a high logic level to a low logic level while SCL is high. All targets on the bus shift in the target address byte on the SCL rising edge, with the last bit indicating whether a read or write

operation is intended. During the ninth clock pulse, the target being addressed responds to the controller by generating an acknowledge bit by pulling SDA low.

Data transfer is then initiated and eight bits of data are sent, followed by an acknowledge bit. During data transfer, SDA must remain stable while SCL is high. Any change in SDA while SCL is high is interpreted as a start or stop condition. When all data are transferred, the controller generates a stop condition, indicated by pulling SDA from low to high while SCL is high. The device includes a 28-ms timeout on the I²C interface to prevent locking up the bus. If the SCL line is held low for this duration of time, the bus state machine is reset.

6.5.1.1 Serial Bus Address

To communicate with the OPT4001-Q1, the controller must first initiate an I²C start command. Then, the controller must address target devices through a target address byte. The target address byte consists of a seven bit address and a direction bit that indicates whether the action is to be a read or write operation.

For the USON variant, four I²C addresses are possible by connecting the ADDR pin to one of four pins: GND, VDD, SDA, or SCL. 表 6-7 summarizes the possible addresses with the corresponding ADDR pin configuration. The state of the ADDR pin is sampled on every bus communication and must be driven or connected to the desired level before any activity on the interface occurs.

表 6-7. ADDR Pin Addresses

ADDR PIN CONNECTION	DEVICE I ² C ADDRESS
GND	1000100
VDD	1000101
SDA	1000110
SCL	1000111

In the case of the PicoStar™ variant there is no target address selection capability and the device address is hard coded to 1000101b (0x45).

6.5.1.2 Serial Interface

The OPT4001-Q1 operates as a target device on both the I²C bus and SMBus. Connections to the bus are made through the SCL clock input line and the SDA open-drain I/O line. The device supports the transmission protocol for standard mode (up to 100 kHz), fast mode (up to 400 kHz), and high-speed mode (up to 2.6 MHz). All data bytes are transmitted most significant bits first.

The SDA and SCL pins feature integrated spike-suppression filters and Schmitt triggers to minimize the effects of input spikes and bus noise. See the [Electrical Interface](#) section for further details of the I²C bus noise immunity.

6.5.2 Writing and Reading

Accessing a specific register on the OPT4001-Q1 is accomplished by writing the appropriate register address during the I²C transaction sequence. See the [Register Maps](#) for a complete list of registers and the corresponding register addresses. The value for the register address (as shown in [Figure 6-5](#)) is the first byte transferred after the target address byte with the R/W bit low.



图 6-5. Setting the I²C Register Address

Writing to a register begins with the first byte transmitted by the controller. This byte is the target address with the R/W bit low. The device then acknowledges receipt of a valid address. The next byte transmitted by the controller is the address of the register that data are to be written to. The next two bytes are written to the register addressed by the register address. The device acknowledges receipt of each data byte. The controller can terminate the data transfer by generating a start or stop condition.

When reading from the device, the last value stored in the register address by a write operation determines which register is read during a read operation. To change the register address for a read operation, a new partial I²C write transaction must be initiated. This partial write is accomplished by issuing a target address byte with the R/W bit low, followed by the register address byte and a stop command. The controller then generates a start condition and sends the target address byte with the R/W bit high to initiate the read command. The next byte is transmitted by the target and is the most significant byte of the register indicated by the register address. This byte is followed by an acknowledge from the controller, then the target transmits the least significant byte. The controller acknowledges receipt of the data byte. The controller can terminate the data transfer by generating a not-acknowledge after receiving any data byte, or by generating a start or stop condition. If repeated reads from the same register are desired, continually sending the register address bytes is not necessary. The device retains the register address until that number is changed by the next write operation.

[图 6-6](#) and [图 6-7](#) show the write and read operation timing diagrams, respectively. Register bytes are sent most significant byte first, followed by the least significant byte.

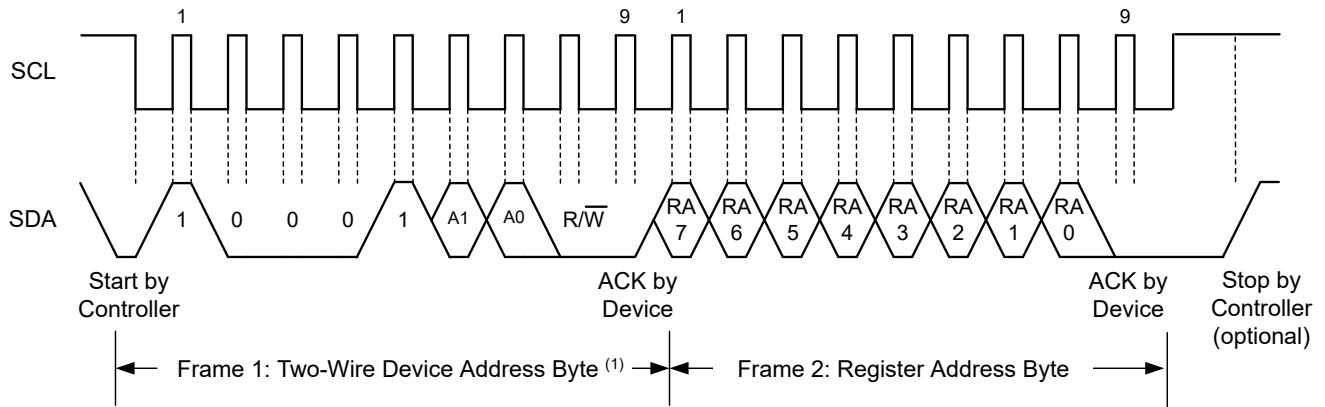

图 6-6. I²C Write Example



A. An ACK by the controller can also be sent.

6-7. I²C Read Example

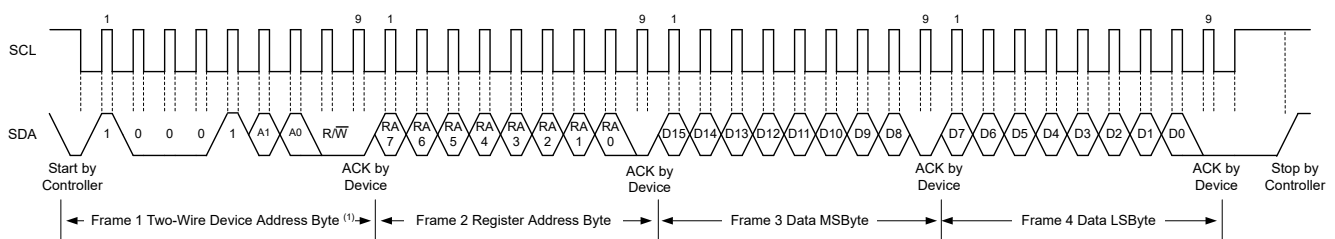
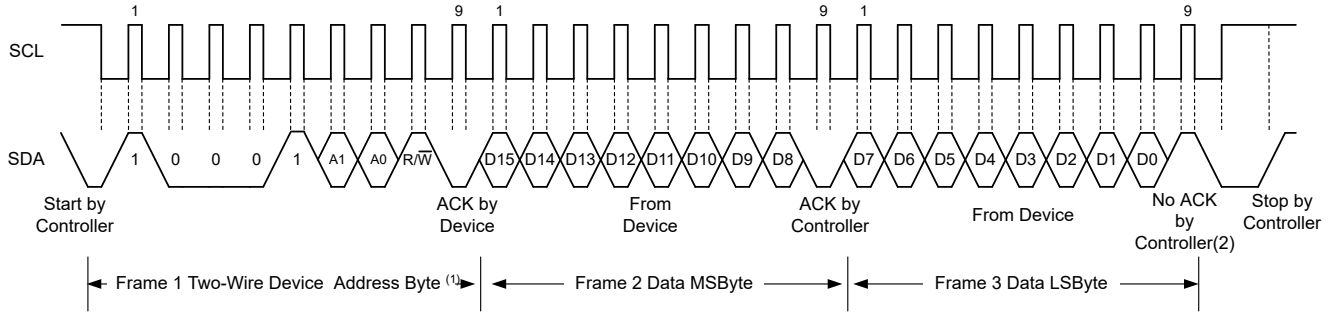
6.5.2.1 High-Speed I²C Mode

When the bus is idle, both the SDA and SCL lines are pulled high by the pullup resistors or active pullup devices. The controller generates a start condition followed by a valid serial byte containing the high-speed (HS) controller code 0000 1XXXb. This transmission is made in either standard mode or fast mode (up to 400 kHz). The device does not acknowledge the HS controller code but does recognize the code and switches the internal filters to support a 2.6-MHz operation.

The controller then generates a repeated start condition (a repeated start condition has the same timing as the start condition). After this repeated start condition, the protocol is the same as F/S mode, except that transmission speeds up to 2.6 MHz are allowed. Instead of using a stop condition, use repeated start conditions to secure the bus in HS mode. A stop condition ends the HS mode and switches all internal filters of the device to support the F/S mode.

6.5.2.2 Burst Read Mode

The OPT4001-Q1 supports I²C burst read mode, which helps minimize the number of transactions on the bus for efficient data transfer from the device to the controller.

Before considering the burst mode, a regular I²C read transaction involves an I²C write operation to the device read pointer, followed by the actual I²C read operation. If regular I²C read transactions are performed when reading from the output registers and FIFO registers, which are in continuous locations, then the register pointer is written every two bytes and this process takes up several clock cycles. With the burst mode enabled, the read pointer address is auto incremented after every register read (two bytes), eliminating the need to write operations to set the pointer for subsequent register reads.

Set the I2C_BURST register to enable burst mode. When a stop command is issued, the pointer resets to the original register address before the auto-increments. 6-8 shows a diagram of the I²C write, single read, and burst mode read operation.



図 6-8. I²C Operations

6.5.2.3 General-Call Reset Command

The I²C general-call reset allows the host controller in one command to reset all devices on the bus that respond to the general-call reset command. Write to the I²C address 0 (0000 0000b) to initiate the general call. The reset command is initiated when the subsequent second address byte is 06h (0000 0110b). With this transaction, the device issues an acknowledge bit and sets all registers to the power-on-reset default condition.

6.5.2.4 SMBus Alert Response (USON Variant)

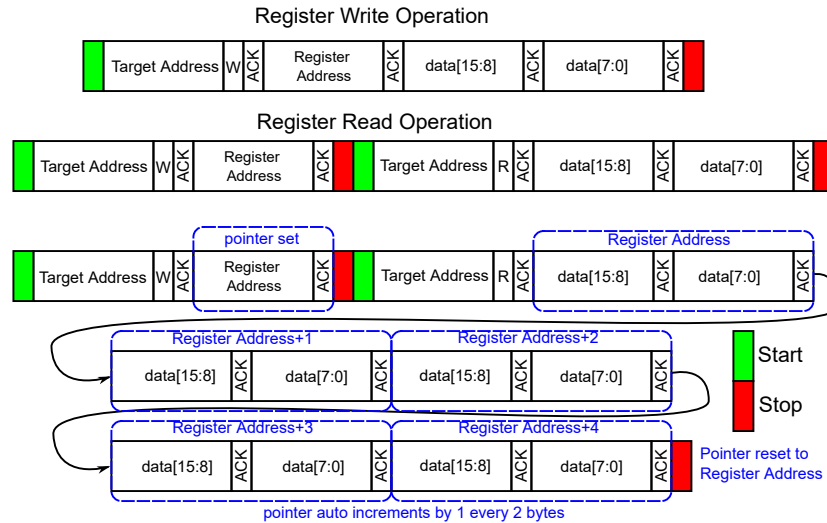
The SMBus alert response provides a quick identification for which device issued the interrupt. Without this alert response capability, the processor can not determine which device pulled the interrupt line (for USON variant only) when there are multiple target devices connected.

The OPT4001-Q1 is designed to respond to the SMBus alert response address when in the latched window-style comparison mode. The OPT4001-Q1 does not respond to the SMBus alert response when in transparent mode.

图 6-9 shows the behavior of the device towards the SMBus alert response. When the interrupt line to the processor is pulled to active, the controller can broadcast the alert response target address. Following this alert response, any target devices that generated an alert identify themselves by acknowledging the alert response and sending the respective I²C address on the bus. The alert response can activate several different target devices simultaneously. If more than one target attempts to respond, bus arbitration rules apply. The device with the lowest address wins the arbitration. If the OPT4001-Q1 loses the arbitration, the device does not acknowledge the I²C transaction and the INT pin remains in an active state, prompting the I²C controller processor to issue a subsequent SMBus alert response. When the OPT4001-Q1 wins the arbitration, the device acknowledges the transaction and sets the INT pin to inactive. The controller can issue that same command again, as many times as necessary to clear the INT pin. See the [Interrupt Modes of Operation](#) section for information on how the flags and INT pin are controlled. The controller can obtain information about the source of the OPT4001-Q1 interrupt from the address broadcast in the above process. The [FLAG_H](#) value is sent as the final LSB of the address to provide the controller additional information about the cause of the OPT4001-Q1 interrupt. If the controller requires additional information, the result register or the configuration register can be queried. The [FLAG_H](#) and [FLAG_L](#) fields are not cleared with an SMBus alert response.

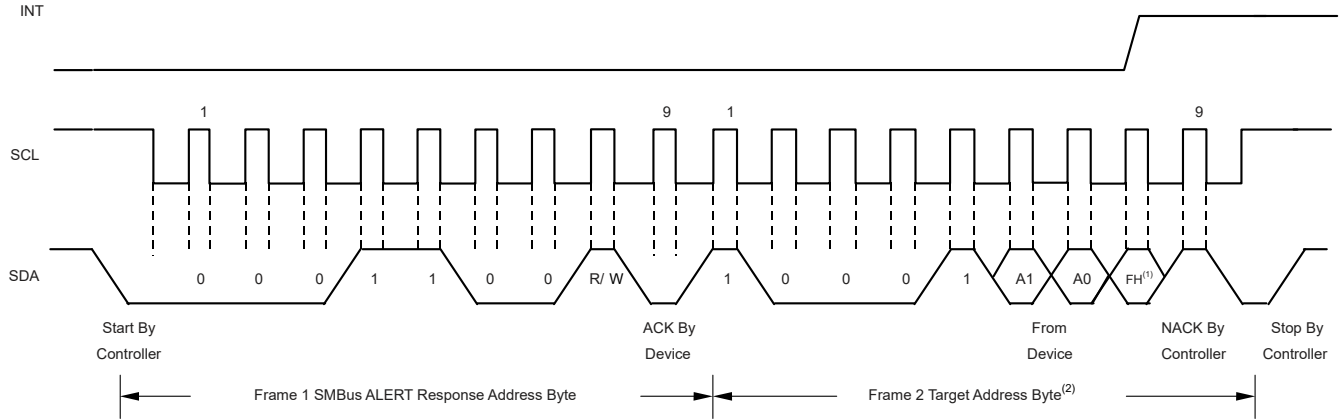

A. FH is the [FLAG_H](#) register.

图 6-9. Timing Diagram for SMBus Alert Response

7 Register Maps

 7-1. ALL Register Map

ADD	D15	D14	D13	D12	D11	D10	D9	D8	D7	D6	D5	D4	D3	D2	D1	D0
00h	EXPONENT						RESULT_MSB									
01h	RESULT_LSB						COUNTER				CRC					
02h	EXPONENT_FIFO0						RESULT_MSB_FIFO0									
03h	RESULT_LSB_FIFO0						COUNTER_FIFO0				CRC_FIFO0					
04h	EXPONENT_FIFO1						RESULT_MSB_FIFO1									
05h	RESULT_LSB_FIFO1						COUNTER_FIFO1				CRC_FIFO1					
06h	EXPONENT_FIFO2						RESULT_MSB_FIFO2									
07h	RESULT_LSB_FIFO2						COUNTER_FIFO2				CRC_FIFO2					
08h	THRESHOLD_L_EXPONENT						THRESHOLD_L_RESULT									
09h	THRESHOLD_H_EXPONENT						THRESHOLD_H_RESULT									
0Ah	QWAKE	0	RANGE				CONVERSION_TIME				OPERATING_MODE		LATCH	INT_POL	FAULT_COUNT	
0Bh	1024										INT_DIR	INT_CFG		0	I2C_BURST	
0Ch	0										OVERLOAD_FLAG	CONVERSION_READY_FLAG	FLAG_H	FLAG_L		
11h	0	DIDL				DIDH										

7.1 Register Descriptions

7.1.1 Register 0h (offset = 0h) [reset = 0h]

☒ 7-2. Register 0h

15	14	13	12	11	10	9	8
EXPONENT				RESULT_MSB			
R-0h				R-0h			
7	6	5	4	3	2	1	0
RESULT_MSB							
R-0h							

LEGEND: R/W = Read/Write; W = Write only; -n = value after reset

☒ 7-3. Register 00 Field Descriptions

Bit	Field	Type	Reset	Description
15-12	EXPONENT	R	0h	EXPONENT output. Determines the full-scale range of the light measurement. Used as a scaling factor for lux calculation
11-0	RESULT_MSB	R	0h	Result register MSB (Most significant bits). Used to calculate the MANTISSA representing light level within a given EXPONENT or full-scale range

7.1.2 Register 1h (offset = 1h) [reset = 0h]

☒ 7-4. Register 1h

15	14	13	12	11	10	9	8
RESULT_LSB							
R-0h							
7	6	5	4	3	2	1	0
COUNTER				CRC			
R-0h				R-0h			

LEGEND: R/W = Read/Write; W = Write only; -n = value after reset

☒ 7-5. Register 01 Field Descriptions

Bit	Field	Type	Reset	Description
15-8	RESULT_LSB	R	0h	Result register LSB (Least significant bits). Used to calculate MANTISSA representing light level within a given EXPONENT or full-scale range
7-4	COUNTER	R	0h	Sample counter. Rolling counter which increments for every conversion
3-0	CRC	R	0h	CRC bits. $R[19:0] = \text{MANTISSA} = ((\text{RESULT_MSB} \ll 8) + \text{RESULT_LSB})$ $X[0] = \text{XOR}(E[3:0], R[19:0], C[3:0])$ XOR of all bits $X[1] = \text{XOR}(C[1], C[3], R[1], R[3], R[5], R[7], R[9], R[11], R[13], R[15], R[17], R[19], E[1], E[3])$ $X[2] = \text{XOR}(C[3], R[3], R[7], R[11], R[15], R[19], E[3])$ $X[3] = \text{XOR}(R[3], R[11], R[19])$

7.1.3 Register 2h (offset = 2h) [reset = 0h]

☒ 7-6. Register 2h

15	14	13	12	11	10	9	8
EXPONENT_FIFO0				RESULT_MSB_FIFO0			
R-0h				R-0h			
7	6	5	4	3	2	1	0
RESULT_MSB_FIFO0							
R-0h							

LEGEND: R/W = Read/Write; W = Write only; -n = value after reset

☒ 7-7. Register 02 Field Descriptions

Bit	Field	Type	Reset	Description
15-12	EXPONENT_FIFO0	R	0h	EXPONENT register from FIFO 0
11-0	RESULT_MSB_FIFO0	R	0h	RESULT_MSB Register from FIFO 0

7.1.4 Register 3h (offset = 3h) [reset = 0h]

☒ 7-8. Register 3h

15	14	13	12	11	10	9	8
RESULT_LSB_FIFO0							
R-0h							
7	6	5	4	3	2	1	0
COUNTER_FIFO0				CRC_FIFO0			
R-0h				R-0h			

LEGEND: R/W = Read/Write; W = Write only; -n = value after reset

☒ 7-9. Register 03 Field Descriptions

Bit	Field	Type	Reset	Description
15-8	RESULT_LSB_FIFO0	R	0h	RESULT_LSB Register from FIFO 0
7-4	COUNTER_FIFO0	R	0h	COUNTER Register from FIFO 0
3-0	CRC_FIFO0	R	0h	CRC Register from FIFO 0

7.1.5 Register 4h (offset = 4h) [reset = 0h]

7-10. Register 4h

15	14	13	12	11	10	9	8
EXPONENT_FIFO1				RESULT_MSB_FIFO1			
R-0h				R-0h			
7	6	5	4	3	2	1	0
RESULT_MSB_FIFO1							
R-0h							

LEGEND: R/W = Read/Write; W = Write only; -n = value after reset

7-11. Register 04 Field Descriptions

Bit	Field	Type	Reset	Description
15-12	EXPONENT_FIFO1	R	0h	EXPONENT register from FIFO 1
11-0	RESULT_MSB_FIFO1	R	0h	RESULT_MSB Register from FIFO 1

7.1.6 Register 5h (offset = 5h) [reset = 0h]

7-12. Register 5h

15	14	13	12	11	10	9	8
RESULT_LSB_FIFO1							
R-0h							
7	6	5	4	3	2	1	0
COUNTER_FIFO1				CRC_FIFO1			
R-0h				R-0h			

LEGEND: R/W = Read/Write; W = Write only; -n = value after reset

7-13. Register 05 Field Descriptions

Bit	Field	Type	Reset	Description
15-8	RESULT_LSB_FIFO1	R	0h	RESULT_LSB Register from FIFO 1
7-4	COUNTER_FIFO1	R	0h	COUNTER Register from FIFO 1
3-0	CRC_FIFO1	R	0h	CRC Register from FIFO 1

7.1.7 Register 6h (offset = 6h) [reset = 0h]

☒ 7-14. Register 6h

15	14	13	12	11	10	9	8
EXPONENT_FIFO2				RESULT_MSB_FIFO2			
R-0h				R-0h			
7	6	5	4	3	2	1	0
RESULT_MSB_FIFO2							
R-0h							

LEGEND: R/W = Read/Write; W = Write only; -n = value after reset

☒ 7-15. Register 06 Field Descriptions

Bit	Field	Type	Reset	Description
15-12	EXPONENT_FIF O2	R	0h	EXPONENT register from FIFO 2
11-0	RESULT_MSB_FI FO2	R	0h	RESULT_MSB Register from FIFO 2

7.1.8 Register 7h (offset = 7h) [reset = 0h]

☒ 7-16. Register 7h

15	14	13	12	11	10	9	8
RESULT_LSB_FIFO2							
R-0h							
7	6	5	4	3	2	1	0
COUNTER_FIFO2				CRC_FIFO2			
R-0h				R-0h			

LEGEND: R/W = Read/Write; W = Write only; -n = value after reset

☒ 7-17. Register 07 Field Descriptions

Bit	Field	Type	Reset	Description
15-8	RESULT_LSB_FI FO2	R	0h	RESULT_LSB Register from FIFO 2
7-4	COUNTER_FIFO 2	R	0h	COUNTER Register from FIFO 2
3-0	CRC_FIFO2	R	0h	CRC Register from FIFO 2

7.1.9 Register 8h (offset = 8h) [reset = 0h]

☒ 7-18. Register 8h

15	14	13	12	11	10	9	8
THRESHOLD_L_EXPONENT				THRESHOLD_L_RESULT			
R/W-0h				R/W-0h			
7	6	5	4	3	2	1	0
THRESHOLD_L_RESULT							
R/W-0h							

LEGEND: R/W = Read/Write; W = Write only; -n = value after reset

☒ 7-19. Register 08 Field Descriptions

Bit	Field	Type	Reset	Description
15-12	THRESHOLD_L_EXPONENT	R/W	0h	Threshold low register exponent
11-0	THRESHOLD_L_RESULT	R/W	0h	Threshold low register result

7.1.10 Register 9h (offset = 9h) [reset = BFFFh]

☒ 7-20. Register 9h

15	14	13	12	11	10	9	8
THRESHOLD_H_EXPONENT				THRESHOLD_H_RESULT			
R/W-Bh				R/W-Fh			
7	6	5	4	3	2	1	0
THRESHOLD_H_RESULT							
R/W-FFh							

LEGEND: R/W = Read/Write; W = Write only; -n = value after reset

☒ 7-21. Register 09 Field Descriptions

Bit	Field	Type	Reset	Description
15-12	THRESHOLD_H_EXPONENT	R/W	Bh	Threshold high register exponent
11-0	THRESHOLD_H_RESULT	R/W	FFFh	Threshold high register result

7.1.11 Register Ah (offset = Ah) [reset = 3208h]

7-22. Register Ah

15	14	13	12	11	10	9	8
QWAKE	0	RANGE				CONVERSION_TIME	
R/W-0h	R/W-0h	R/W-Ch				R/W-2h	
7	6	5	4	3	2	1	0
CONVERSION_TIME		OPERATING_MODE		LATCH	INT_POL	FAULT_COUNT	
R/W-0h		R/W-0h		R/W-1h	R/W-0h	R/W-0h	

LEGEND: R/W = Read/Write; W = Write only; -n = value after reset

7-23. Register 0A Field Descriptions

Bit	Field	Type	Reset	Description
15-15	QWAKE	R/W	0h	Quick wake-up from standby in one-shot mode by not powering down all circuits. Applicable only in one-shot mode and helps get out of standby mode faster with penalty in power consumption compared to full standby mode.
14-14	0	R/W	0h	Must read or write 0
13-10	RANGE	R/W	Ch	Controls the full-scale light level range of the device. The format of this register is same as the EXPONENT register for all values from 0 to 8. PicoStar™ variant: 0 : 328lux 1 : 655lux 2 : 1.3klux 3 : 2.6klux 4 : 5.2klux 5 : 10.5klux 6 : 21klux 7 : 42klux 8 : 83klux 12 : Auto-Range USON variant: 0 : 419lux 1 : 839lux 2 : 1.7klux 3 : 3.3klux 4 : 6.7klux 5 : 13.4klux 6 : 26.7klux 7 : 53.7klux 8 : 107klux 12 : Auto-Range
9-6	CONVERSION_TIME	R/W	8h	Controls the device conversion time 0 : 600μs 1 : 1ms 2 : 1.8ms 3 : 3.4ms 4 : 6.5ms 5 : 12.7ms 6 : 25ms 7 : 50ms 8 : 100ms 9 : 200ms 10 : 400ms 11 : 800ms
5-4	OPERATING_MODE	R/W	0h	Controls device mode of operation 0 : Power-down 1 : Forced auto-range One-shot 2 : One-shot 3 : Continuous

☒ 7-23. Register 0A Field Descriptions (続き)

Bit	Field	Type	Reset	Description
3-3	LATCH	R/W	1h	Controls the functionality of the interrupt reporting mechanisms for INT pin (USON variant only) for the threshold detection logic.
2-2	INT_POL	R/W	0h	Controls the polarity or active state of the INT pin (USON variant only). 0 : Active Low 1 : Active High
1-0	FAULT_COUNT	R/W	0h	Fault count register instructs the device as to how many consecutive fault events are required to trigger the threshold mechanisms: the flag high (FLAG_H) and the flag low (FLAG_L) registers. 0 : One fault Count 1 : Two Fault Counts 2 : Four Fault Counts 3 : Eight Fault Counts

7.1.12 Register Bh (offset = Bh) [reset = 8011h]

☒ 7-24. Register Bh

15	14	13	12	11	10	9	8
1	0	0	0	0	0	0	0
R/W-1h	R/W-0h	R/W-0h	R/W-0h	R/W-0h	R/W-0h	R/W-0h	R/W-0h
7	6	5	4	3	2	1	0
0	0	0	INT_DIR	INT_CFG		0	I2C_BURST
R/W-0h	R/W-0h	R/W-0h	R/W-1h	R/W-0h		R/W-0h	R/W-1h

LEGEND: R/W = Read/Write; W = Write only; -n = value after reset

☒ 7-25. Register 0B Field Descriptions

Bit	Field	Type	Reset	Description
15-5	1024	R/W	400h	Must read or write 1024
4-4	INT_DIR	R/W	1h	Determines the direction of the INT pin (USON variant only). 0 : Input 1 : Output
3-2	INT_CFG	R/W	0h	Controls the output interrupt mechanism after end of conversion (USON variant only). 0 : SMBUS Alert 1 : INT Pin asserted after every conversion 2 : Invalid 3 : INT pin asserted after every 4 conversions (FIFO full)
1-1	0	R/W	0h	Must read or write 0
0-0	I2C_BURST	R/W	1h	When set, enables I2C burst mode minimizing I2C read cycles by auto incrementing read register pointer by 1 after every register read

7.1.13 Register Ch (offset = Ch) [reset = 0h]

7-26. Register Ch

15	14	13	12	11	10	9	8
0	0	0	0	0	0	0	0
R/W-0h	R/W-0h	R/W-0h	R/W-0h	R/W-0h	R/W-0h	R/W-0h	R/W-0h
7	6	5	4	3	2	1	0
0	0	0	0	OVERLOAD_F LAG	CONVERSION _READY_FLAG	FLAG_H	FLAG_L
R/W-0h	R/W-0h	R/W-0h	R/W-0h	R-0h	R-0h	R-0h	R-0h

LEGEND: R/W = Read/Write; W = Write only; -n = value after reset

7-27. Register 0C Field Descriptions

Bit	Field	Type	Reset	Description
15-4	0	R/W	0h	Must read or write 0
3-3	OVERLOAD_FL AG	R	0h	Indicates when an overflow condition occurs in the data conversion process, typically because the light illuminating the device exceeds the full-scale range.
2-2	CONVERSION_R EADY_FLAG	R	0h	Conversion ready flag indicates when a conversion completes. The flag is set to 1 at the end of a conversion and is cleared (set to 0) when register address 0xC is either read or written with any non-zero value 0 : Conversion in progress 1 : Conversion is complete
1-1	FLAG_H	R	0h	Flag high register identifies that the result of a conversion is measurement than a specified level of interest. FLAG_H is set to 1 when the result is larger than the level in the THRESHOLD_H_EXPONENT and THRESHOLD_H_RESULT registers for a consecutive number of measurements defined by the FAULT_COUNT register.
0-0	FLAG_L	R	0h	Flag low register identifies that the result of a measurement is smaller than a specified level of interest. FL is set to 1 when the result is smaller than the level in the THRESHOLD_LOW_EXPONENT and THRESHOLD_L_RESULT registers for a consecutive number of measurements defined by the FAULT_COUNT register.

7.1.14 Register 11h (offset = 11h) [reset = 121h]

☒ 7-28. Register 11h

15	14	13	12	11	10	9	8
0	0	DIDL		DIDH			
R/W-0h	R/W-0h	R-0h		R-1h			
7	6	5	4	3	2	1	0
DIDH							
R-21h							

LEGEND: R/W = Read/Write; W = Write only; -n = value after reset

☒ 7-29. Register 11 Field Descriptions

Bit	Field	Type	Reset	Description
15-14	0	R/W	0h	Must read or write 0
13-12	DIDL	R	0h	Device ID L
11-0	DIDH	R	121h	Device ID H

8 Application and Implementation

注

Information in the following applications sections is not part of the TI component specification, and TI does not warrant its accuracy or completeness. TI's customers are responsible for determining suitability of components for their purposes, as well as validating and testing their design implementation to confirm system functionality.

8.1 Application Information

Because ambient light sensors are used in a wide variety of applications that require precise measurement of light as perceived by the human eye, the sensors have a specialized filter that mimics the human eye. The following sections show crucial information about integrating the OPT4001-Q1 in applications.

8.2 Typical Application

8.2.1 Electrical Interface

As shown in [Figure 8-1](#), the electrical interface is quite simple. Connect the OPT4001-Q1 I²C SDA and SCL pins to the same pins of an applications processor, microcontroller, or other digital processor. If that digital processor requires an interrupt resulting from an event of interest from the OPT4001-Q1, then connect the INT pin to either an interrupt or general-purpose I/O pin of the processor (INT pin is only available for USON package variant). There are multiple uses for this INT pin, including triggering a measurement on one-shot mode, signaling the system to wake up from low-power mode, processing other tasks while waiting for an ambient light event of interest, or alerting the processor that a sample is ready to be read. Connect pullup resistors between a power supply appropriate for digital communication and the SDA and SCL pins (because the pins have open-drain output structures). If the INT pin is used, connect a pullup resistor to the INT pin. A typical value for these pullup resistors is 10 k Ω . The resistor choice can be optimized in conjunction to the bus capacitance to balance the system speed, power, noise immunity, and other requirements.

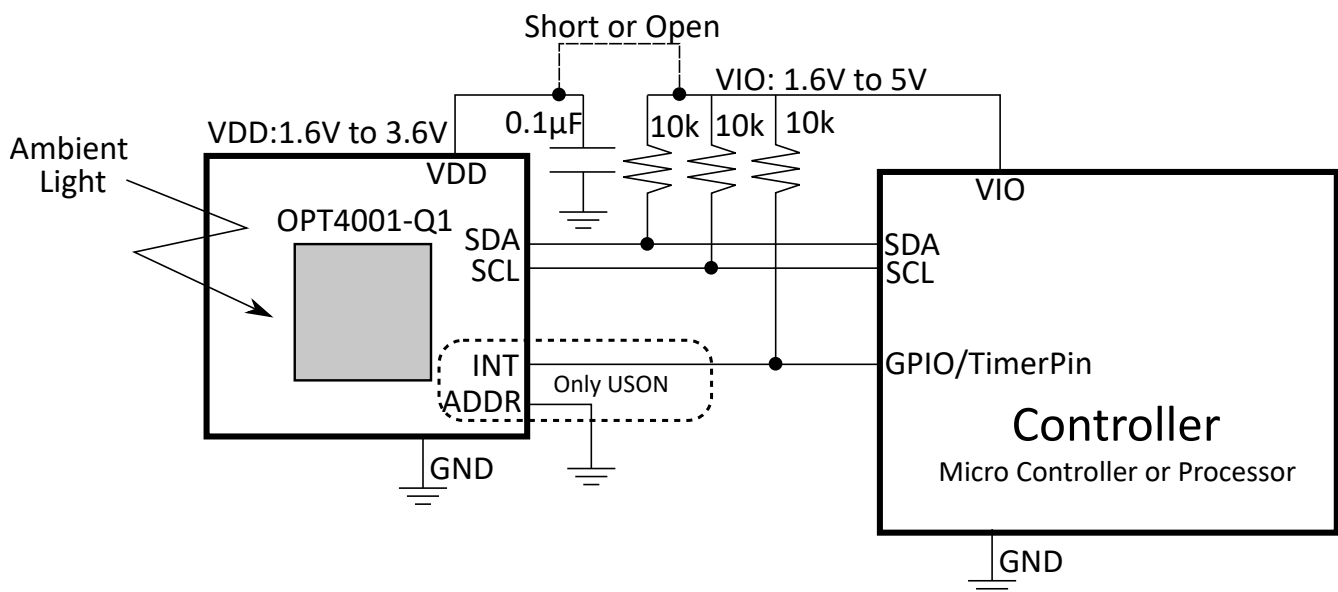

Figure 8-1. Typical Application Schematic

The power-supply and grounding considerations are discussed in the [Power Supply Recommendations](#) section.

Although spike suppression is integrated in the SDA and SCL pin circuits, use proper layout practices to minimize the amount of coupling into the communication lines. One possible introduction of noise occurs from

capacitively coupling signal edges between the two communication lines. Another possible noise introduction comes from other switching noise sources present in the system, especially for long communication lines. In noisy environments, shield communication lines to reduce the possibility of unintended noise coupling into the digital I/O lines that can be incorrectly interpreted.

8.2.1.1 Design Requirements

This section describes the design requirements for a light sensor integrated into a system behind an enclosure cutout with a dark glass. This application is a common example of a light sensor system integration. Key considerations, such as sensor field of view (FoV) and dark glass transmission, are discussed in the [Optical Interface](#) section.

8.2.1.1.1 Optical Interface

Figure 8-3 shows the dimensions of the optical area.

The optical interface is physically located on the same side of the device pins as the electrical interface for the PicoStar™ variant and facing away from the pins for the USON variant, as shown in Figure 8-2 and Figure 8-3.

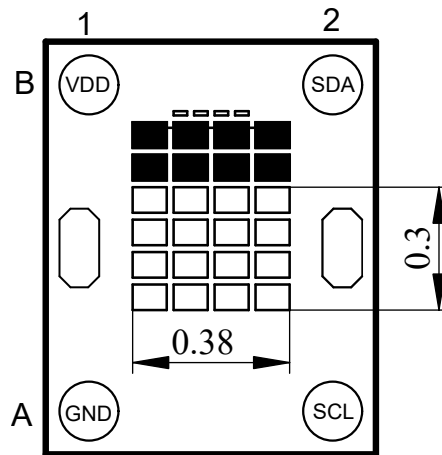

Figure 8-2. PicoStar™ Sensor Position



図 8-3. USON Sensor Position

In case of the PicoStar™ variant systems, light that illuminates the sensor must come through the FPCB. Typically, the best method is to create a cutout area in the FPCB. Other methods are possible, but with associated design tradeoffs. This cutout must be carefully designed because the dimensions and tolerances impact the net-system, optical field-of-view performance. The design of this cutout is discussed more in [セクション 8.5.2](#).

Generally, any physical component that affects the light illuminating the sensing area of a light sensor also affects the performance of that light sensor. For example, a dark or opaque window can be used to further enhance the visual appeal of the design by hiding the sensor from view. This window material is typically transparent plastic or glass. Therefore, for the best performance, make sure to understand and control the effect of these components. Design a window width and height to permit light from a sufficient field of view to illuminate the sensor. For best performance, use a field of view of at least $\pm 35^\circ$, or preferably $\pm 45^\circ$ or more. Understanding and designing the field of view is discussed further in the [OPT3001: Ambient Light Sensor Application Guide application note](#).

The visible-spectrum transmission for dark windows typically ranges between 5% to 30%, but can be less than 1%. Specify a visible-spectrum transmission as low as, but no more than, necessary to achieve sufficient visual appeal because decreased transmission decreases the available light for the sensor to measure. The windows are made dark by either applying an ink to a transparent window material, or including a dye or other optical substance within the window material. This attenuating transmission in the visible spectrum of the window creates a ratio between the light on the outside of the design and the light that is measured by the device. To accurately measure the light outside of the design, compensate the device measurement for this ratio.

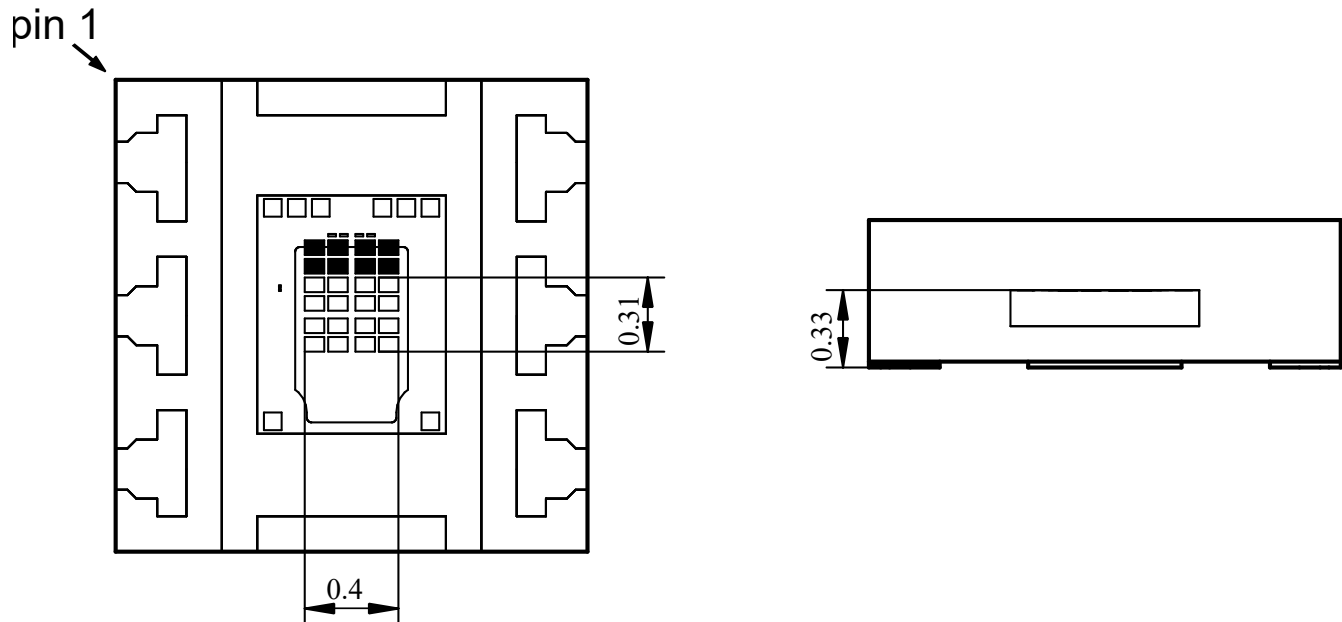
Although the inks and dyes of dark windows serve a primary purpose of being minimally transmissive to visible light, some inks and dyes can also be very transmissive to infrared light. The use of these inks and dyes further decreases the ratio of visible to infrared light, and thus decreases sensor measurement accuracy. However, because of the excellent red and infrared rejection of the device, this effect is minimized, and good results are achieved under a dark window with similar spectral responses.

For best accuracy, avoid grill-like window structures, unless the designer understands the optical effects sufficiently. These grill-like window structures create a nonuniform illumination pattern on the sensor that causes light measurement results to vary with placement tolerances and the angle of incidence of the light. If a grill-like structure is desired, then this device is an excellent sensor choice because the device is minimally sensitive to illumination uniformity issues disrupting the measurement process.

Light pipes can appear attractive for aiding in the optomechanical design that brings light to the sensor; however, do not use light pipes with any light sensor unless the system designer fully understands the ramifications of the optical physics of light pipes within the full context of the design and objectives.

8.2.1.2 Detailed Design Procedure

8.2.1.2.1 Optomechanical Design (*PicoStar™ Variant*)

After completing the electrical design and understanding optical interface, the next task is the optomechanical design of the FPCB cutout. Design this cutout in conjunction with the tolerance capabilities of the FPCB manufacturer. Or, conversely, choose the FPCB manufacturer for the capabilities of creating this cutout. A semi-rectangular shape of the cutout, created with a standard FPCB laser, is presented here. There are many alternate approaches with different cost, tolerance, and performance tradeoffs.

An image of the created FPCB with the plus shaped cutout and a rectangular shaped cutout is shown below. The plus shape is a good choice for light collection in both directions with a wider field of view. In case of the rectangular cutout shape, the long (vertical) direction of the cutout has minimal effect on the angular response because any shadows created from the FPCB do not come near the sensor. The long cutout direction defines the axis of rotation with the less restricted field of view. The narrow (horizontal) direction of the cutout, which is limited by the electrical connections to OPT4001-Q1, can create shadows that can have a minor impact on the angular response. The narrow cutout direction defines the axis of rotation of the more restricted view. The possibility of shadows are illustrated in [Figure 8-6](#), a cross-sectional diagram showing the OPT4001 device, with the sensing area, soldered to the FPCB with the cutout. A circular cutout is more restrictive in the field of view casting shadow from all directions of light. TI recommends accounting for the effect of shadows and the impact on the field of view of the sensor. The product folder has application notes and tools to help understand these artifacts.

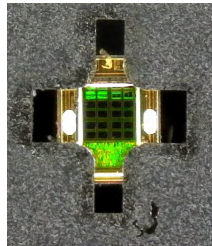

Figure 8-4. Image of FPCB With OPT4001-Q1 Mounted, Receiving Light Through the Cutout With a Plus Shape

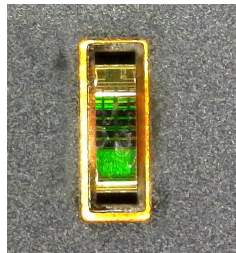

Figure 8-5. Image of FPCB With OPT4001-Q1 Mounted, Receiving Light Through the Cutout With a Rectangular Shape



図 8-6. Cross-Sectional Diagram of OPT4001-Q1 Soldered to an FPCB With a Cutout, Including Light Entering From an Angle

There can be an additional need to put a product casing over the assembly of the device and the FPCB. The window sizing and placement for such an assembly is discussed in more rigorous detail in the [OPT3001: Ambient Light Sensor Application Guide](#) application note.

8.2.1.2.2 Optomechanical Design (USON Variant)

After completing the electrical design, the next task is the optomechanical design. Window sizing and placement is discussed in more rigorous detail in the [OPT3001: Ambient Light Sensor Application Guide](#) application note.

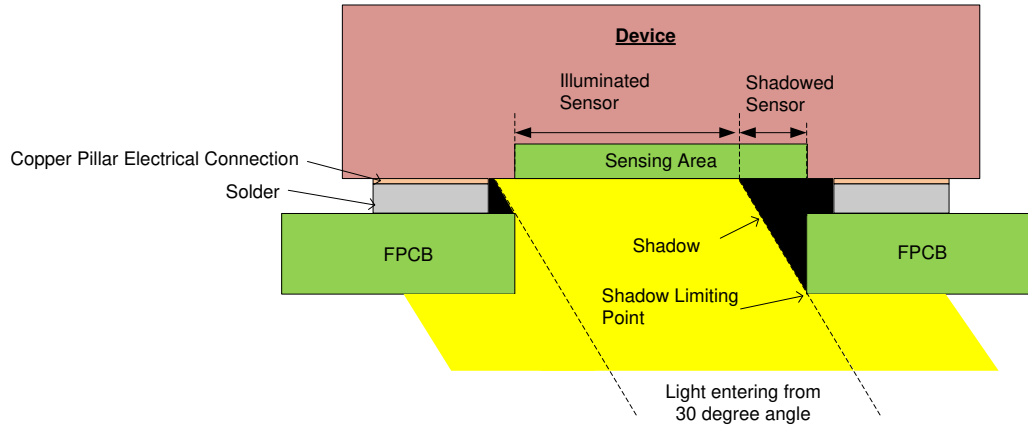
8.2.1.3 Application Curves (PicoStar™ Variant)

[☒ 8-7](#) and [☒ 8-8](#) show example response curves of the device for a rectangular cut out hole as shown in [☒ 8-16](#). The shape of the cutout affects the overall light collection and the field of view can clearly be seen.

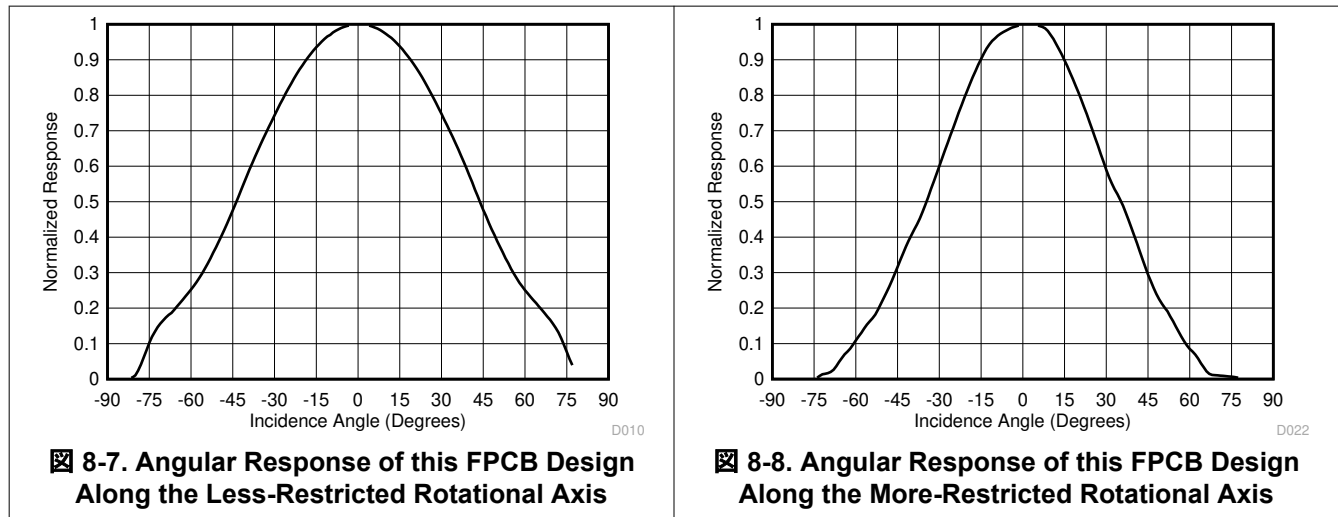

8.2.1.4 Application Curves (USON Variant)

The sensor spectral matching to the human eye photopic response (see [☒ 5-2](#)) determines the sensor capability of reporting accurate light intensity readings across lighting conditions. The bare device response over angle is illustrated in [☒ 5-3](#). Both of these curves can be effected when the sensor is integrated at the system level. The [OPT3001: Ambient Light Sensor Application Guide](#) application note gives more details on integrating the light sensor and system-level design considerations.

8.3 Best Design Practices

As with any optical product, take special care when handling the OPT4001-Q1. The optical surface of the device must be kept clean for the best performance, both when prototyping with the device and during mass production manufacturing procedures. Keep the optical surface clean of fingerprints, dust, and other optical-inhibiting contaminants. Use a properly-sized vacuum manipulation tool to handle the device.

If the optical surface of the device requires cleaning, then use a few gentle brushes with a soft swab of deionized water or isopropyl alcohol. Avoid potentially abrasive cleaning and manipulating tools and excessive force that can scratch the optical surface.

If the OPT4001-Q1 performance is diminished in any way, then inspect the optical surface for dirt, scratches, or other optical artifacts.

8.4 Power Supply Recommendations

Although the OPT4001-Q1 has low sensitivity to power-supply issues, good practices are always recommended. For best performance, the device VDD pin must have a stable, low-noise power supply with a 100-nF bypass capacitor close to the device and solid grounding. There are many options for powering the device because of the device low current consumption levels.

8.5 Layout

8.5.1 Layout Guidelines

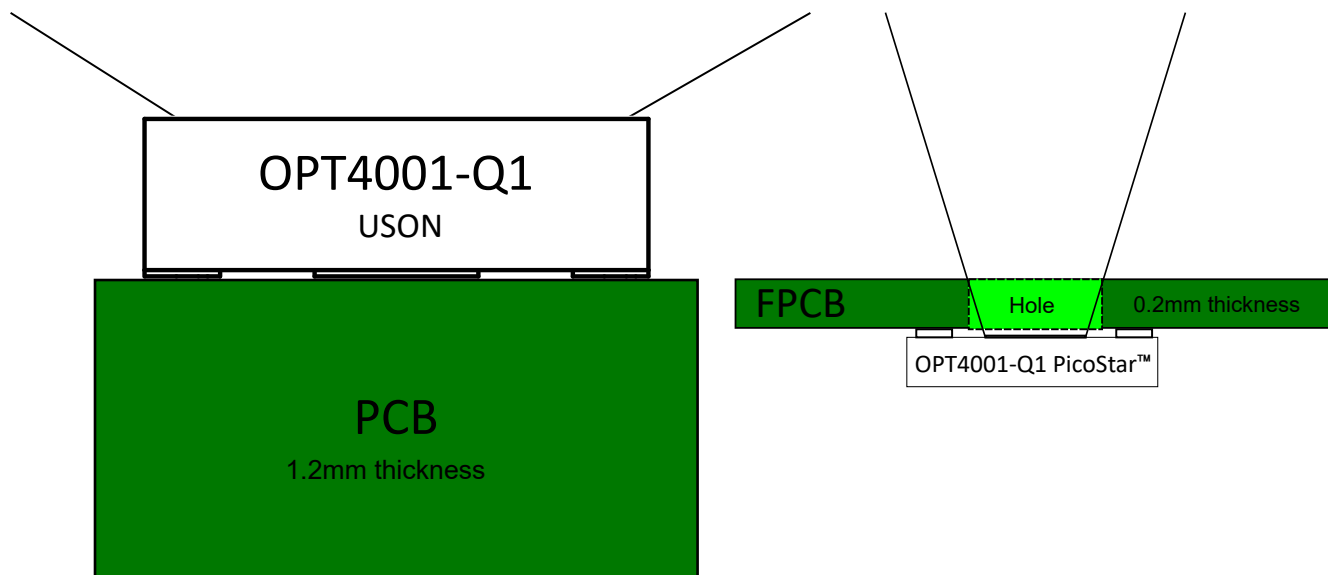

☒ 8-9. Placement Side View of Packages

In the case of the USON package variant of the device, since the lighting sensitive area and the device pins are on opposite sides of each other, a conventional placement on the PCB provides good light collection. In the case of the PicoStar™ variant of the device, since the light sensitive area and the device pins are on the same side, a special arrangement as shown in ☒ 8-9 is required to achieve good light collection. Typically, a thin flexible PCB with a hole or a cutout centered around the optical area is required for wide-angle light collection for the PicoStar™ variant. A regular PCB can be used but the amount of light collected and the field of view of light collection are not very good and generally not recommended. The cut out for the light collection can be of any shape with a large enough opening to let ample light fall on the light sensitive area. ☒ 8-15 and ☒ 8-16 show examples of two shapes which help maximize light collection. A circular cut out as large as manufacturing allows is acceptable but can restrict the field of view and reduce the light collection. Tools and documentation are available on TI's product folder to estimate the field of view based on the hole size.

TI highly recommends placing the decoupling capacitor close to the device, but remember that optically reflective surfaces of components also affect the performance of the design. Consider the three-dimensional geometry of all components and structures around the sensor to prevent unexpected results from secondary optical reflections. Placing capacitors and components at a distance of at least twice the height of the component is usually sufficient. The best optical layout is to place all close components on the opposite side of the PCB from the OPT4001-Q1. However, this approach is not practical for the constraints of every design.

The device layout is also critical for good SMT assembly. Two types of land pattern pads can be used for this package: solder mask defined pads (SMD) and non-solder mask defined pads (NSMD). SMD pads have a solder mask opening that is smaller than the metal pads, whereas, NSMD has a solder mask opening that is larger than the metal pad. ☒ 8-10 illustrates these types of landing-pattern pads. SMD pads are preferred because these pads provide a more accurate soldering-pad dimension with the trace connections. For further discussion of SMT and PCB recommendations, see the [Soldering and Handling Recommendations \(USON Variant\)](#) section.



図 8-10. Solder Mask Defined Pad (SMD) and Non-Solder Mask Defined Pad (NSMD)

8.5.1.1 Soldering and Handling Recommendations (PicoStar™ Variant)

The OPT4001-Q1 is a small device with special soldering and handling considerations. See [セクション 8.2.1.2.1](#) for implications of alignment between the device and the cutout area. See [セクション 8.5.1](#) for considerations of the soldering pads.

If the OPT4001-Q1 must be removed from a PCB, discard the device and do not reattach.

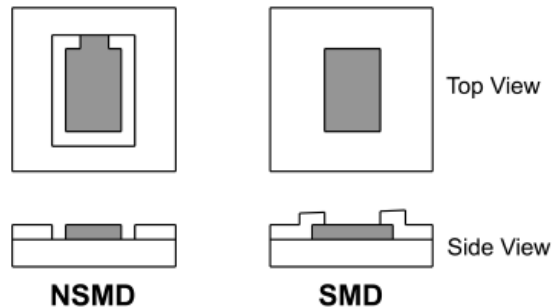
注

Excessive heat can discolor the device and affect optical performance.

As with most optical devices, handle the OPT4001-Q1 with special care to make sure that optical surfaces stay clean and free from damage. See [セクション 8.3](#) for more detailed recommendations. For best optical performance, solder flux and any other possible debris must be cleaned after soldering processes.

8.5.1.1.1 Solder Paste

For solder-paste deposition, use a stencil-printing process that involves the transfer of solder paste through predefined apertures with the application of pressure. Stencil parameters, such as aperture area ratio and fabrication process, have a significant impact on paste deposition. Cut the stencil apertures using a laser with an electropolish-fabrication method. Taper the stencil aperture walls by 5° to facilitate paste release. Shifting the solder-paste towards the outside of the device minimizes the possibility of solder getting into the device sensing area. See the mechanical packages attached to the end of this data sheet.

Use solder paste selection type 4 or higher, no-clean, lead-free solder paste. If solder splatters in the reflow process, choose a solder paste with normal- or low-flux contents, or alter the reflow profile per the [セクション 8.5.1.1.3](#).

8.5.1.1.2 Package Placement

Use a pick-and-place nozzle with a size number larger than 0.6 mm. If the placement method is done by programming the component thickness, then add 0.04 mm to the actual component thickness so that the package sits halfway into the solder paste.

For device placement, please choose a force no greater than 3N to avoid pushing out the solder paste, dislodging the package, solder bridging, or solder balling.

8.5.1.1.3 Reflow Profile

Use the profile in [図 8-11](#), and adjust if necessary. Use a slow solder reflow ramp rate of 1°C to 1.2°C/s to minimize chances of solder splattering onto the sensing area.

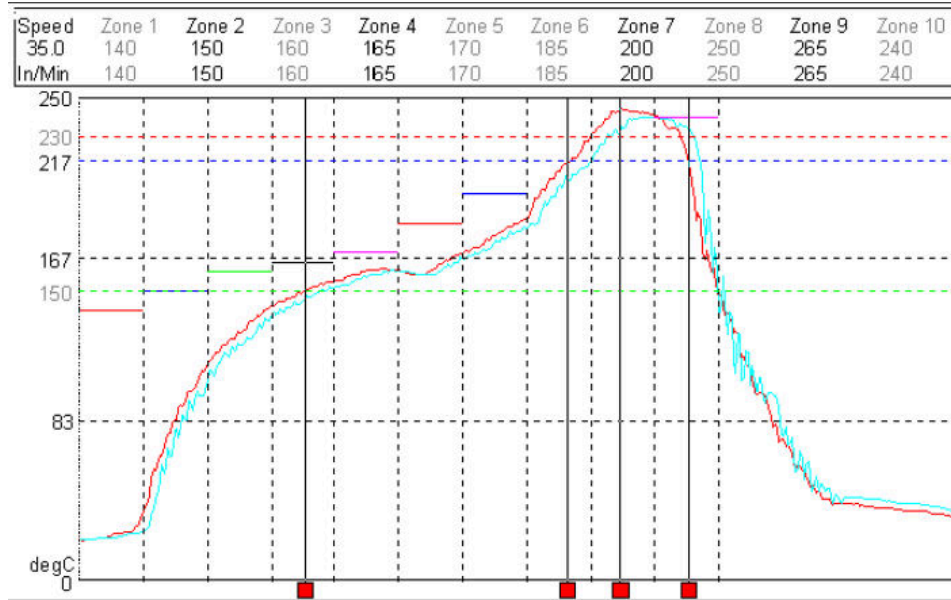

☒ 8-11. Recommended Solder Reflow Temperature Profile

8.5.1.1.4 Special Flexible Printed-Circuit Board (FPCB) Recommendations

Special flexible printed-circuit board (FPCB) design recommendations include:

- Fabricate per IPC-6013.
- Use material of flexible copper clad per IPC 4204/11 (Define polyimide and copper thickness per product application).
- Finish: All exposed copper is electroless Ni immersion gold (ENIG) per IPC 4556.
- Solder mask per IPC SM840.
- Use a laser to create the cutout for light sensing for better accuracy and to avoid affecting the soldering pad dimension. Other options, such as punched cutouts, are possible. See the [セクション 8.2.1.2.1](#) for further discussions, ranging from the implications of the device to cutout region size and alignment. The full design must be considered, including the tolerances.

To assist the handling of the very thin flexible circuit, design and fabricate a fixture to hold the flexible circuit through the paste-printing, pick-and-place, and reflow processes. Contact the factory for examples of such fixtures.

8.5.1.1.5 Rework Process

Discard the device and do not reattach if the device must be removed from a PCB. To remove the package from the PCB/Flexi cable, heat the solder joints above liquidus temperature. Bake the board at 125°C for 4 hours prior to rework to remove moisture that can crack the PCB or causing delamination. Use a thermal heating profile to remove a package that is close to the profile that mounts the package. Clean the site to remove any excess solder and residue to prepare for installing a new package. Use a mini stencil (localized stencil) to apply solder paste to the land pattern. In case a mini stencil cannot be used because of spacing or other reasons, apply solder paste on the package pads directly, then mount, and reflow.

8.5.1.2 Soldering and Handling Recommendations (USON Variant)

The OPT4001-Q1 is qualified for three soldering reflow operations as per JEDEC JSTD-020.

注

Excessive heat can discolor the device and affect optical performance.

See the [QFN and SON PCB Attachment](#) application note for details on the soldering thermal profile and other information. Discard the device and do not reattach if the OPT4001-Q1 must be removed from a PCB.

As with most optical devices, take special care to make sure that optical surfaces of the device stay clean and free from damage. See [セクション 8.3](#) for more detailed recommendations. For best optical performance, solder flux and any other possible debris must be cleaned after the soldering processes.

☒ 8-12 shows how to identify pin 1 on the bottom side of the package. ☒ 8-13 shows various identification features for pin 1 on the top side of the package.

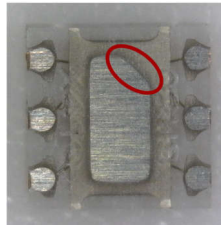

NOTE: The bottom side of the device features an angled feature to denote pin 1.

☒ 8-12. Identification Feature for Pin 1

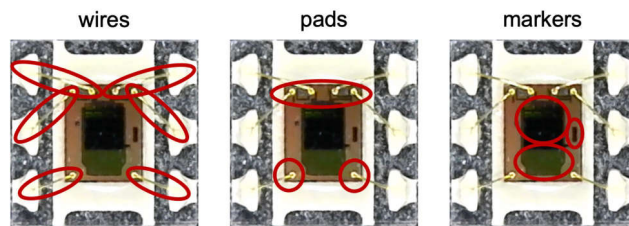

☒ 8-13. Identification Features for Pin 1 on the Package

8.5.2 Layout Example

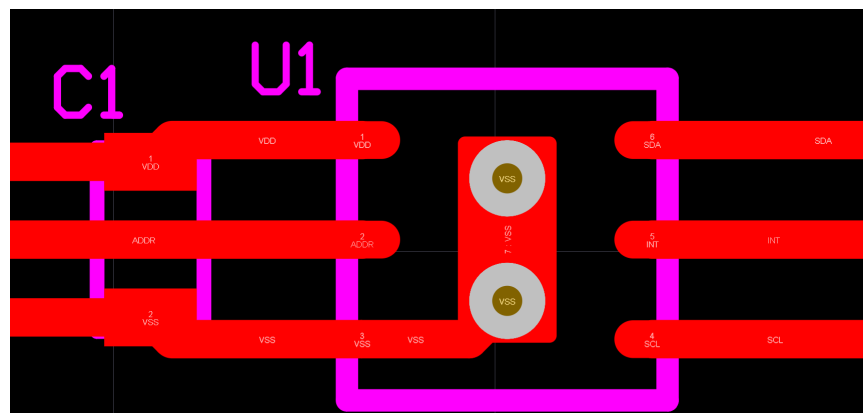

☒ 8-14. Layout Example for DNP Package



図 8-15. Layout Example for YMN Package With Plus-Shaped Cut Out



図 8-16. Layout Example for YMN Package With Rectangular Cut Out

9 デバイスおよびドキュメントのサポート

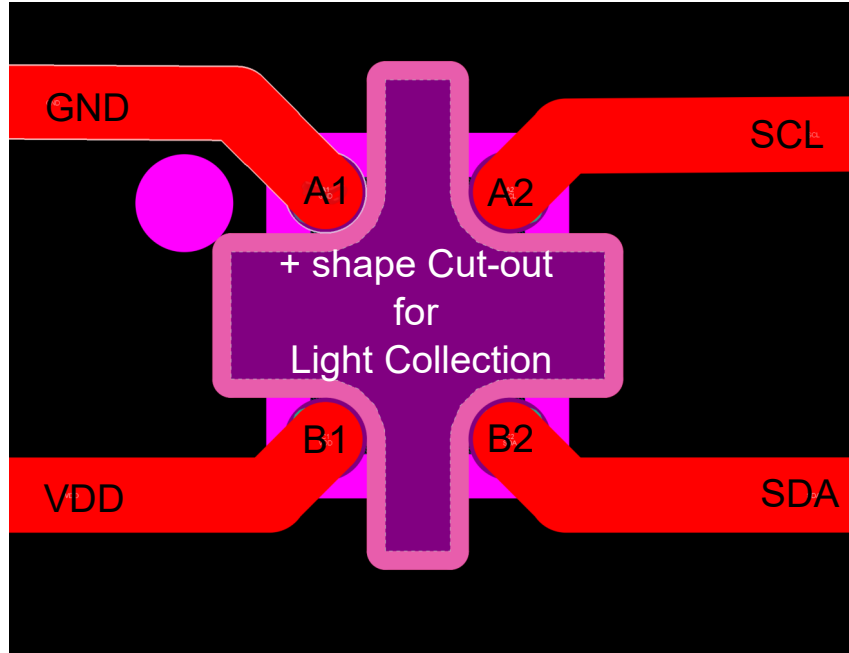
9.1 ドキュメントのサポート

9.1.1 Related Documentation

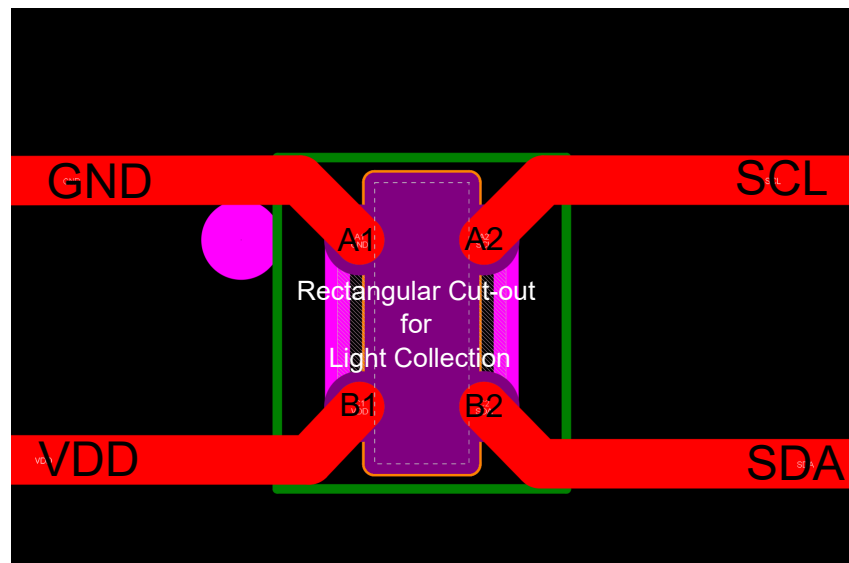
For related documentation see the following:

- Texas Instruments, [OPT3001: Ambient Light Sensor Application Guide](#), application note
- Texas Instruments, [OPT4001EVM](#), user's guide
- Texas Instruments, [QFN and SON PCB Attachment](#), application note

9.2 ドキュメントの更新通知を受け取る方法

ドキュメントの更新についての通知を受け取るには、www.tij.co.jp のデバイス製品フォルダを開いてください。[通知] をクリックして登録すると、変更されたすべての製品情報に関するダイジェストを毎週受け取ることができます。変更の詳細については、改訂されたドキュメントに含まれている改訂履歴をご覧ください。

9.3 サポート・リソース

[テキサス・インスツルメンツ E2E™ サポート・フォーラム](#)は、エンジニアが検証済みの回答と設計に関するヒントをエキスパートから迅速かつ直接得ることができる場所です。既存の回答を検索したり、独自の質問をしたりすることで、設計に必要な支援を迅速に得ることができます。

リンクされているコンテンツは、各寄稿者により「現状のまま」提供されるものです。これらはテキサス・インスツルメンツの仕様を構成するものではなく、必ずしもテキサス・インスツルメンツの見解を反映したものではありません。テキサス・インスツルメンツの[使用条件](#)を参照してください。

9.4 Trademarks

PicoStar™ and テキサス・インスツルメンツ E2E™ are trademarks of Texas Instruments.

すべての商標は、それぞれの所有者に帰属します。

9.5 静電気放電に関する注意事項



この IC は、ESD によって破損する可能性があります。テキサス・インスツルメンツは、IC を取り扱う際には常に適切な注意を払うことを推奨します。正しい取り扱いおよび設置手順に従わない場合、デバイスを破損するおそれがあります。

ESD による破損は、わずかな性能低下からデバイスの完全な故障まで多岐にわたります。精密な IC の場合、パラメータがわずかに変化するだけで公表されている仕様から外れる可能性があるため、破損が発生しやすくなっています。

9.6 用語集

[テキサス・インスツルメンツ用語集](#)

この用語集には、用語や略語の一覧および定義が記載されています。

10 Revision History

資料番号末尾の英字は改訂を表しています。その改訂履歴は英語版に準じています。

Changes from Revision B (January 2024) to Revision C (June 2024)	Page
• ドキュメント全体にわたって表、図、相互参照の採番方法を更新.....	1
• 「特長」に PicoStar™ パッケージを追加.....	1
• Added PicoStar™ package.....	3
• Added PicoStar™ spectral response vs wavelength and device response vs illuminance angle.....	9
• Added range selection settings for PicoStar™ package.....	17
• Added <i>Resolution Table</i> for the PicoStar™ package.....	19
• Added PicoStar™ sensor position.....	37
• Added <i>Optomechanical Design (PicoStar™ Variant)</i>	39
• Added <i>Application Curves (PicoStar™ Variant)</i>	41
• Added PicoStar™ package placement view.....	42

• Added Soldering and Handling Recommendations (PicoStar™ Variant)	43
• Added layout examples for PicoStar™ package.....	45

Changes from Revision A (July 2023) to Revision B (January 2024)	Page
• Added <i>Timing Requirements</i>	8
• Added <i>Timing Diagram</i>	8

Changes from Revision * (May 2023) to Revision A (July 2023)	Page
• ドキュメントのステータスを「事前情報」から「量産データ」に変更	1

11 Mechanical, Packaging, and Orderable Information

The following pages include mechanical, packaging, and orderable information. This information is the most current data available for the designated devices. This data is subject to change without notice and revision of this document. For browser-based versions of this data sheet, refer to the left-hand navigation.

重要なお知らせと免責事項

テキサス・インスツルメンツは、技術データと信頼性データ (データシートを含みます)、設計リソース (リファレンス デザインを含みます)、アプリケーションや設計に関する各種アドバイス、Web ツール、安全性情報、その他のリソースを、欠陥が存在する可能性のある「現状のまま」提供しており、商品性および特定目的に対する適合性の黙示保証、第三者の知的財産権の非侵害保証を含むいかなる保証も、明示的または黙示的にかかわらず拒否します。

これらのリソースは、テキサス・インスツルメンツ製品を使用する設計の経験を積んだ開発者への提供を意図したものです。(1) お客様のアプリケーションに適した テキサス・インスツルメンツ製品の選定、(2) お客様のアプリケーションの設計、検証、試験、(3) お客様のアプリケーションに該当する各種規格や、その他のあらゆる安全性、セキュリティ、規制、または他の要件への確実な適合に関する責任を、お客様のみが単独で負うものとします。

上記の各種リソースは、予告なく変更される可能性があります。これらのリソースは、リソースで説明されている テキサス・インスツルメンツ製品を使用するアプリケーションの開発の目的でのみ、テキサス・インスツルメンツはその使用をお客様に許諾します。これらのリソースに関して、他の目的で複製することや掲載することは禁止されています。テキサス・インスツルメンツや第三者の知的財産権のライセンスが付与されている訳ではありません。お客様は、これらのリソースを自身で使用した結果発生するあらゆる申し立て、損害、費用、損失、責任について、テキサス・インスツルメンツおよびその代理人を完全に補償するものとし、テキサス・インスツルメンツは一切の責任を拒否します。

テキサス・インスツルメンツの製品は、[テキサス・インスツルメンツの販売条件](#)、または [ti.com](https://www.ti.com) やかかる テキサス・インスツルメンツ製品の関連資料などのいずれかを通じて提供する適用可能な条項の下で提供されています。テキサス・インスツルメンツがこれらのリソースを提供することは、適用されるテキサス・インスツルメンツの保証または他の保証の放棄の拡大や変更を意味するものではありません。

お客様がいかなる追加条項または代替条項を提案した場合でも、テキサス・インスツルメンツはそれらに異議を唱え、拒否します。

郵送先住所: Texas Instruments, Post Office Box 655303, Dallas, Texas 75265

Copyright © 2024, Texas Instruments Incorporated

PACKAGING INFORMATION

Orderable Device	Status (1)	Package Type	Package Drawing	Pins	Package Qty	Eco Plan (2)	Lead finish/ Ball material (6)	MSL Peak Temp (3)	Op Temp (°C)	Device Marking (4/5)	Samples
OPT4001DNPRQ1	ACTIVE	USON	DNP	6	3000	RoHS & Green	NIPDAUAG	Level-3-260C-168 HR	-40 to 105	1Q	Samples
POPT4001YMNRQ1	ACTIVE	PICOSTAR	YMN	4	3000	TBD	Call TI	Call TI	-40 to 125		Samples

(1) The marketing status values are defined as follows:

ACTIVE: Product device recommended for new designs.

LIFEBUY: TI has announced that the device will be discontinued, and a lifetime-buy period is in effect.

NRND: Not recommended for new designs. Device is in production to support existing customers, but TI does not recommend using this part in a new design.

PREVIEW: Device has been announced but is not in production. Samples may or may not be available.

OBSOLETE: TI has discontinued the production of the device.

(2) **RoHS:** TI defines "RoHS" to mean semiconductor products that are compliant with the current EU RoHS requirements for all 10 RoHS substances, including the requirement that RoHS substance do not exceed 0.1% by weight in homogeneous materials. Where designed to be soldered at high temperatures, "RoHS" products are suitable for use in specified lead-free processes. TI may reference these types of products as "Pb-Free".

RoHS Exempt: TI defines "RoHS Exempt" to mean products that contain lead but are compliant with EU RoHS pursuant to a specific EU RoHS exemption.

Green: TI defines "Green" to mean the content of Chlorine (Cl) and Bromine (Br) based flame retardants meet JS709B low halogen requirements of <=1000ppm threshold. Antimony trioxide based flame retardants must also meet the <=1000ppm threshold requirement.

(3) MSL, Peak Temp. - The Moisture Sensitivity Level rating according to the JEDEC industry standard classifications, and peak solder temperature.

(4) There may be additional marking, which relates to the logo, the lot trace code information, or the environmental category on the device.

(5) Multiple Device Markings will be inside parentheses. Only one Device Marking contained in parentheses and separated by a "~" will appear on a device. If a line is indented then it is a continuation of the previous line and the two combined represent the entire Device Marking for that device.

(6) Lead finish/Ball material - Orderable Devices may have multiple material finish options. Finish options are separated by a vertical ruled line. Lead finish/Ball material values may wrap to two lines if the finish value exceeds the maximum column width.

Important Information and Disclaimer:The information provided on this page represents TI's knowledge and belief as of the date that it is provided. TI bases its knowledge and belief on information provided by third parties, and makes no representation or warranty as to the accuracy of such information. Efforts are underway to better integrate information from third parties. TI has taken and continues to take reasonable steps to provide representative and accurate information but may not have conducted destructive testing or chemical analysis on incoming materials and chemicals. TI and TI suppliers consider certain information to be proprietary, and thus CAS numbers and other limited information may not be available for release.

In no event shall TI's liability arising out of such information exceed the total purchase price of the TI part(s) at issue in this document sold by TI to Customer on an annual basis.

OTHER QUALIFIED VERSIONS OF OPT4001-Q1 :

- Catalog : [OPT4001](#)

NOTE: Qualified Version Definitions:

- Catalog - TI's standard catalog product

重要なお知らせと免責事項

TI は、技術データと信頼性データ (データシートを含みます)、設計リソース (リファレンス・デザインを含みます)、アプリケーションや設計に関する各種アドバイス、Web ツール、安全性情報、その他のリソースを、欠陥が存在する可能性のある「現状のまま」提供しており、商品性および特定目的に対する適合性の黙示保証、第三者の知的財産権の非侵害保証を含むいかなる保証も、明示的または黙示的にかかわらず拒否します。

これらのリソースは、TI 製品を使用する設計の経験を積んだ開発者への提供を意図したものです。(1) お客様のアプリケーションに適した TI 製品の選定、(2) お客様のアプリケーションの設計、検証、試験、(3) お客様のアプリケーションに該当する各種規格や、その他のあらゆる安全性、セキュリティ、規制、または他の要件への確実な適合に関する責任を、お客様のみが単独で負うものとし、

上記の各種リソースは、予告なく変更される可能性があります。これらのリソースは、リソースで説明されている TI 製品を使用するアプリケーションの開発の目的でのみ、TI はその使用をお客様に許諾します。これらのリソースに関して、他の目的で複製することや掲載することは禁止されています。TI や第三者の知的財産権のライセンスが付与されている訳ではありません。お客様は、これらのリソースを自身で使用した結果発生するあらゆる申し立て、損害、費用、損失、責任について、TI およびその代理人を完全に補償するものとし、TI は一切の責任を拒否します。

TI の製品は、[TI の販売条件](#)、または [ti.com](#) やかかる TI 製品の関連資料などのいずれかを通じて提供する適用可能な条項の下で提供されています。TI がこれらのリソースを提供することは、適用される TI の保証または他の保証の放棄の拡大や変更を意味するものではありません。

お客様がいかなる追加条項または代替条項を提案した場合でも、TI はそれらに異議を唱え、拒否します。

郵送先住所 : Texas Instruments, Post Office Box 655303, Dallas, Texas 75265
Copyright © 2024, Texas Instruments Incorporated