

# PCA9534 割り込み出力および構成レジスタ付き、リモート 8 ビット I<sup>2</sup>C/SMBus 低消費電力 I/O エクスパンダ

## 1 特長

- 低いスタンバイ消費電流: 1μA 以下
- I<sup>2</sup>C からパラレル・ポートへのエクスパンダ
- オープン・ドレインのアクティブ LOW 割り込み出力
- 2.3V~5.5V の動作電源電圧範囲
- 5V 許容の I/O ポート
- 400kHz の高速 I<sup>2</sup>C バス
- 3 本のアドレス・ピンにより、最大 8 個のデバイスを I<sup>2</sup>C/SMBus に接続可能
- **PCA9534A** と組み合わせて使用した場合、最大 16 のデバイスを I<sup>2</sup>C/SMBus に接続可能
- I<sup>2</sup>C エクスパンダ製品については、[セクション 5](#) を参照してください。
- 入力 / 出力構成レジスタ
- 極性反転レジスタ
- パワーオン・リセット機能を内蔵
- 電源投入時はすべてのチャンネルが入力に構成された状態
- 電源オン時のグリッチなし
- SCL/SDA 入力でのノイズ・フィルタ
- 大電流の最大駆動能力を持つラッチ付き出力により、LED を直接駆動
- JESD 78、Class II 準拠で 100mA 超のラッチアップ性能
- JESD 22 を超える ESD 保護
  - 2000V、人体モデル (A114-A)
  - 200V、マシン・モデル (A115-A)
  - 1000V、デバイス帯電モデル (C101)

## 2 概要

この 2 線式双方向バス (I<sup>2</sup>C) 用 8 ビット I/O エクスパンダは、2.3V~5.5V の V<sub>CC</sub> で動作するように設計されています。

す。I<sup>2</sup>C インターフェイス [シリアル・クロック (SCL)、シリアル・データ (SDA)] により、ほとんどのマイクロコントローラ・ファミリの汎用リモート I/O 拡張に使用できます。

PCA9534 は、構成 (入力 / 出力選択)、入力ポート、出力ポート、極性反転 (アクティブ HIGH またはアクティブ LOW 動作) 用の 8 ビット・レジスタをそれぞれ 2 個ずつ搭載しています。電源オン時に、I/O は入力として構成されます。しかし、システム・マスタは、I/O 構成ビットに書き込むことで、I/O を入力または出力として有効にできます。それぞれの入力または出力のデータは、対応する入力または出力レジスタに保持されます。入力ポート・レジスタの極性は、極性反転レジスタで反転できます。すべてのレジスタをシステム・マスタで読み出すことができます。

タイムアウトまたはその他の不適切な動作が発生した場合、システム・マスタはパワーオン・リセット機能を利用して PCA9534 をリセットできます。これにより、レジスタはデフォルト状態になり、I<sup>2</sup>C/SMBus ステート・マシンは初期化されます。

PCA9534 のオープン・ドレイン割り込み ( $\overline{\text{INT}}$ ) 出力は、いずれかの入力の状態が、対応する入力ポート・レジスタの状態と異なっている場合にアクティブになるため、入力状態が変化したことをシステム・マスタに示すために使用されます。

### 製品情報<sup>(1)</sup>

部品番号	パッケージ	本体サイズ (公称)
PCA9534	SSOP (16)	6.20mm × 5.30mm
	VQFN (16)	4.00mm × 4.00mm
	QFN (16)	3.00mm × 3.00mm

- (1) 利用可能なすべてのパッケージについては、このデータシートの末尾にある注文情報を参照してください。

DB, DGV, DW, OR PW PACKAGE  
(TOP VIEW)

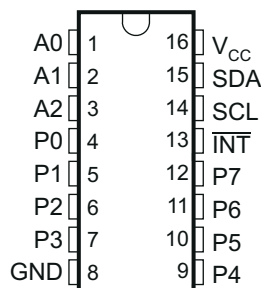

RGV PACKAGE  
(TOP VIEW)

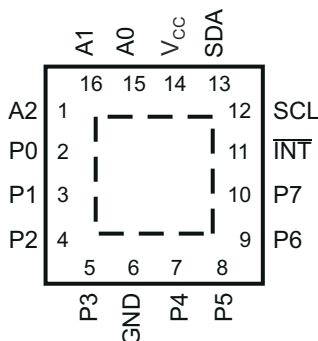

RGT PACKAGE  
(TOP VIEW)

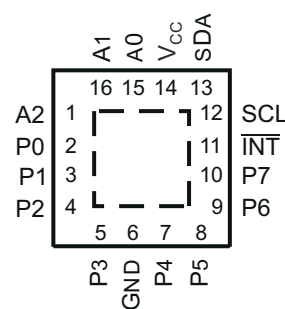

## Table of Contents

<b>1 特長</b> .....	<b>1</b>	<b>9 Detailed Description</b> .....	<b>15</b>
<b>2 概要</b> .....	<b>1</b>	9.1 Functional Block Diagram.....	15
<b>3 Revision History</b> .....	<b>2</b>	9.2 Device Functional Modes.....	16
<b>4 概要 (続き)</b> .....	<b>3</b>	9.3 Programming.....	17
<b>5 Device Comparison Table</b> .....	<b>4</b>	<b>10 Application Information Disclaimer</b> .....	<b>23</b>
<b>6 Pin Configuration and Functions</b> .....	<b>5</b>	10.1 Application Information.....	23
<b>7 Specifications</b> .....	<b>6</b>	<b>11 Power Supply Recommendations</b> .....	<b>25</b>
7.1 Absolute Maximum Ratings.....	6	11.1 Power-On Reset Requirements.....	25
7.2 ESD Ratings.....	6	<b>12 Device and Documentation Support</b> .....	<b>27</b>
7.3 Recommended Operating Conditions.....	6	12.1 ドキュメントの更新通知を受け取る方法.....	27
7.4 Thermal Resistance Characteristics.....	6	12.2 サポート・リソース.....	27
7.5 Electrical Characteristics.....	7	12.3 Trademarks.....	27
7.6 I <sup>2</sup> C Interface Timing Requirements.....	8	12.4 静電気放電に関する注意事項.....	27
7.7 Switching Characteristics.....	8	12.5 用語集.....	27
7.8 Typical Characteristics.....	9	<b>13 Mechanical, Packaging, and Orderable Information</b> .....	<b>27</b>
<b>8 Parameter Measurement Information</b> .....	<b>12</b>		

## 3 Revision History

Changes from Revision G (May 2014) to Revision H (March 2021)	Page
• Moved the "Storage temperature range" to the <i>Absolute Maximum Ratings</i> .....	6
• Moved the "Package thermal impedance" to the <i>Thermal Resistance Characteristic</i> .....	6
• Changed the V <sub>IH</sub> High-level input voltage (SDL, SDA) Max value From: 5.5 V To: V <sub>CC</sub> in the <i>Recommended Operating Conditions</i> .....	6
• Changed the V <sub>IH</sub> High-level input voltage (A0, A1, A2, P7–P0) MIN value From: 2 V To: V <sub>CC</sub> in the <i>Recommended Operating Conditions</i> .....	6
• Changed the V <sub>IL</sub> Low-level input voltage (A0, A1, A2, P7–P0) MAX value From: 0.8 V To: 0.3 x V <sub>CC</sub> in the <i>Recommended Operating Conditions</i> .....	6
• Added the <i>Thermal Resistance Characteristics</i> .....	6
• Changed the V <sub>PORR</sub> row in the <i>Electrical Characteristics</i> .....	7
• Added the V <sub>PORF</sub> row in the <i>Electrical Characteristics</i> .....	7
• Changed the I <sub>CC</sub> Standby mode values in the <i>Electrical Characteristics</i> .....	7
• Changed the ΔI <sub>CC</sub> Additional current in standby mode (5.5 V) mAX value From: 1 mA To: 4 mA in the <i>Electrical Characteristics</i> .....	7
• Changed the C <sub>i</sub> SCL Max value From: 5 pF To: 8 pF in the <i>Electrical Characteristics</i> .....	7
• Changed the C <sub>io</sub> SDA Max value From: 6.5 pF To: 9.5 pF in the <i>Electrical Characteristics</i> .....	7
• Changed the t <sub>pv</sub> Output data valid MAX values From: 200 ns To 350 ns in the <i>Switcing Characteristics</i> .....	8
• Changed the <i>Typical Characteristics</i> graphs.....	9
• Changed the <i>Power Supply Recommendations</i> .....	25

Changes from Revision F (June 2010) to Revision G (June 2014)	Page
• Added Interrupt Errata section.....	17

## 4 概要 (続き)

$\overline{\text{INT}}$  はマイクロコントローラの割り込み入力に接続できます。この配線で割り込み信号を送ることでリモート I/O は、I<sup>2</sup>C バス経由で通信しなくてもポート上に受信データが存在するかどうかをマイクロコントローラに通知できます。そのため、PCA9534 はシンプル・スレーブ・デバイスとして機能できます。

本デバイスの出力 (ラッチ付き) は大電流駆動能力を備えているため、LED を直接駆動できます。本デバイスは低消費電流です。

3 本のハードウェア・ピン (A0、A1、A2) を使って固定 I<sup>2</sup>C アドレスをプログラムおよび変更することで、最大 8 つのデバイスが同じ I<sup>2</sup>C バスまたは SMBus を共有できます。

PCA9534 は PCF8574 とピン互換、I<sup>2</sup>C アドレス互換です。しかし PCA9534 では、PCF8574 に対して機能が拡張されているため、ソフトウェアを変更する必要があります。

PCA9534 は PCA9554 の低消費電力バージョンです。PCA9534 と PCA9554 の唯一の違いは、PCA9534 では内部 I/O プルアップ抵抗が除去されていることです。そのため、I/O を LOW に保持する際のスタンバイ・モードの消費電力が大幅に低減されています。

PCA9534A と PCA9534 は、固定 I<sup>2</sup>C アドレスを除くと同じです。そのため、これらのデバイス最大 16 個 (各 8 個) を同じ I<sup>2</sup>C に接続できます。

## 5 Device Comparison Table

DEVICE	MAX FREQUENCY	I <sup>2</sup> C ADDRESSES	NO. OF GPIOs	INTERRUPT OUTPUT	RESET INPUT	CONFIGURATION REGISTERS	5-V TOLERANT	PUSH-PULL I/O TYPE	OPEN-DRAIN I/O TYPE	COMMENT
<b>V<sub>CC</sub> = 1.65 to 5.5 V</b>										
TCA6408	400	0100 00x	8	Yes	Yes	Yes	Yes	Yes	No	Power on reset, t <sub>r</sub> (fall time) > 100 ms and t <sub>r</sub> (ramp time) < 10 ms
TCA6408	400	0100 00x	8	Yes	Yes	Yes	Yes	Yes	No	Unrestricted power on reset ramp/fall time. Both t <sub>r</sub> (fall time) and TRT (ramp time) can be between 0.1 ms and 2000 ms
TCA6416	400	0100 00x	16	Yes	Yes	Yes	Yes	Yes	No	Power on reset, t <sub>r</sub> (fall time) > 100 ms and TRT (ramp time) < 10 ms
TCA6416A	400	0100 00x	16	Yes	Yes	Yes	Yes	Yes	No	Unrestricted power on reset ramp/fall time. Both t <sub>r</sub> (fall time) and TRT (ramp time) can be between 0.1 ms and 2000ms
TCA6424	400	0100 00x	24	Yes	Yes	Yes	Yes	Yes	No	Power on reset, t <sub>r</sub> (fall time) > 100 ms and TRT (ramp time) < 10 ms
TCA9535	400	0100 xxx	16	Yes	No	Yes	Yes	Yes	No	
TCA9539	400	1110 1xx	16	Yes	Yes	Yes	Yes	Yes	No	
TCA9555	400	0100 xxx	16	Yes	No	Yes	Yes	Yes	No	
<b>V<sub>CC</sub> = 2.3 to 5.5 V</b>										
PCA6107	400	0011 xxx	8	Yes	Yes	Yes	Yes	Yes P1–P7 bits	Yes P0 bit	One open drain output; eight push pull outputs
PCA9534	400	0100 xxx	8	Yes	No	Yes	Yes	Yes	No	PCA9534 has a different slave address as the PCA9534A, allowing up to 16 devices '9534 type devices on the same I <sup>2</sup> C bus
PCA9534A	400	0111 xxx	8	Yes	No	Yes	Yes	Yes	No	PCA9534A has a different slave address as the PCA9534, allowing up to 16 devices '9534 type devices on the same I <sup>2</sup> C bus
PCA9535	400	0100 xxx	16	Yes	No	Yes	Yes	Yes	No	
PCA9536	400	1000 001	4	No	No	Yes	Yes	Yes	No	
PCA9538	400	1110 0xx	8	Yes	Yes	Yes	Yes	Yes	No	
PCA9539	400	1110 1xx	16	Yes	Yes	Yes	Yes	Yes	No	
PCA9554	400	0100 xxx	8	Yes	No	Yes	Yes	Yes	No	
PCA9554A	400	0111 xxx	8	Yes	No	Yes	Yes	Yes	No	
PCA9555	400	0100 xxx	16	Yes	No	Yes	Yes	Yes	No	
PCA9557	400	0011 xxx	8	No	Yes	Yes	Yes	Yes	Yes	
<b>V<sub>CC</sub> = 2.5 to 6.0 V</b>										
PCF8574	400	0100 xxx	8	Yes	No	No	Yes	Yes	No	PCA8574 has a different slave address as the PCA8574A, allowing up to 16 devices '9534 type devices on the same I <sup>2</sup> C bus
PCF8574A	400	0111 xxx	8	Yes	No	No	Yes	Yes	No	PCA8574A has a different slave address as the PCA8574, allowing up to 16 devices '9534 type devices on the same I <sup>2</sup> C bus
<b>V<sub>CC</sub> = 2.5 to 5.5 V</b>										
PCF8575	400	0100 xxx	16	Yes	No	No	Yes	Yes	No	
PCF8575C	400	0100 xxx	16	Yes	No	No	Yes	No	Yes	

## 6 Pin Configuration and Functions

DB, DGV, DW, OR PW PACKAGE  
(TOP VIEW)

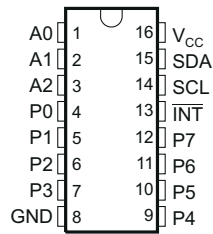

RGV PACKAGE  
(TOP VIEW)

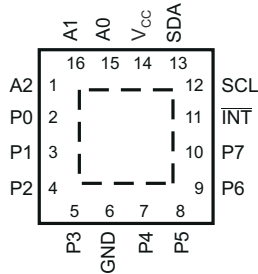

RGT PACKAGE  
(TOP VIEW)



表 6-1. Pin Functions

PIN			DESCRIPTION
NAME	SOIC (DW), SSOP (DB), TSSOP (PW), AND TVSOP (DGV)	QFN (RGT AND RGV)	
A0	1	15	Address input. Connect directly to V <sub>CC</sub> or ground.
A1	2	16	Address input. Connect directly to V <sub>CC</sub> or ground.
A2	3	1	Address input. Connect directly to V <sub>CC</sub> or ground.
P0	4	2	P-port input/output. Push-pull design structure.
P1	5	3	P-port input/output. Push-pull design structure.
P2	6	4	P-port input/output. Push-pull design structure.
P3	7	5	P-port input/output. Push-pull design structure.
GND	8	6	Ground
P4	9	7	P-port input/output. Push-pull design structure.
P5	10	8	P-port input/output. Push-pull design structure.
P6	11	9	P-port input/output. Push-pull design structure.
P7	12	10	P-port input/output. Push-pull design structure.
$\overline{\text{INT}}$	13	11	Interrupt output. Connect to V <sub>CC</sub> through a pullup resistor.
SCL	14	12	Serial clock bus. Connect to V <sub>CC</sub> through a pullup resistor.
SDA	15	13	Serial data bus. Connect to V <sub>CC</sub> through a pullup resistor.
V <sub>CC</sub>	16	14	Supply voltage

## 7 Specifications

### 7.1 Absolute Maximum Ratings

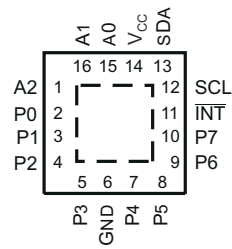
over operating free-air temperature range (unless otherwise noted) <sup>(1)</sup>

		MIN	MAX	UNIT
V <sub>CC</sub>	Supply voltage range	-0.5	6	V
V <sub>I</sub>	Input voltage range <sup>(2)</sup>	-0.5	6	V
V <sub>O</sub>	Output voltage range <sup>(2)</sup>	-0.5	6	V
I <sub>IK</sub>	Input clamp current	V <sub>I</sub> < 0	-20	mA
I <sub>OK</sub>	Output clamp current	V <sub>O</sub> < 0	-20	mA
I <sub>IOK</sub>	Input/output clamp current	V <sub>O</sub> < 0 or V <sub>O</sub> > V <sub>CC</sub>	±20	mA
I <sub>OL</sub>	Continuous output low current	V <sub>O</sub> = 0 to V <sub>CC</sub>	50	mA
I <sub>OH</sub>	Continuous output high current	V <sub>O</sub> = 0 to V <sub>CC</sub>	-50	mA
I <sub>CC</sub>	Continuous current through GND		-250	mA
	Continuous current through V <sub>CC</sub>		160	
T <sub>stg</sub>	Storage temperature range	-65	150	°C

- (1) Stresses beyond those listed under "absolute maximum ratings" may cause permanent damage to the device. These are stress ratings only, and functional operation of the device at these or any other conditions beyond those indicated under "recommended operating conditions" is not implied. Exposure to absolute-maximum-rated conditions for extended periods may affect device reliability.
- (2) The input negative-voltage and output voltage ratings may be exceeded if the input and output current ratings are observed.

### 7.2 ESD Ratings

			MIN	MAX	UNIT
V <sub>(ESD)</sub>	Electrostatic discharge	Human body model (HBM), per ANSI/ESDA/JEDEC JS-001, all pins <sup>(1)</sup>	0	2000	V
		Charged device model (CDM), per JEDEC specification JESD22-C101, all pins <sup>(2)</sup>	0	1000	

- (1) JEDEC document JEP155 states that 500-V HBM allows safe manufacturing with a standard ESD control process.
- (2) JEDEC document JEP157 states that 250-V CDM allows safe manufacturing with a standard ESD control process.

### 7.3 Recommended Operating Conditions

		MIN	MAX	UNIT
V <sub>CC</sub>	Supply voltage	2.3	5.5	V
V <sub>IH</sub>	High-level input voltage	SCL, SDA	0.7 × V <sub>CC</sub>	V <sub>CC</sub>
		A0, A1, A2, P7–P0	0.7 × V <sub>CC</sub>	5.5
V <sub>IL</sub>	Low-level input voltage	SCL, SDA	-0.5	0.3 × V <sub>CC</sub>
		A0, A1, A2, P7–P0	-0.5	0.3 × V <sub>CC</sub>
I <sub>OH</sub>	High-level output current	P7–P0	-10	mA
I <sub>OL</sub>	Low-level output current	P7–P0	25	mA
T <sub>A</sub>	Operating free-air temperature	-40	85	°C

### 7.4 Thermal Resistance Characteristics

THERMAL METRIC <sup>(1)</sup>		PCA9535						UNIT
		DB (SSOP)	DBQ (SSOP)	DVG (TVSOP)	DW (SOIC)	PW (TSSOP)	RGV (VQFN)	
		16 PINS	16 PINS	16 PINS	16 PINS	16 PINS	16 PINS	
R <sub>θJA</sub>	Junction-to-ambient thermal resistance	92.9	61	86	108.8	48.4	43.6	°C/W

- (1) For more information about traditional and new thermal metrics, see the [Semiconductor and IC package thermal metrics](#) application report.

## 7.5 Electrical Characteristics

over operating free-air temperature range (unless otherwise noted)

PARAMETER		TEST CONDITIONS	V <sub>CC</sub>	MIN	TYP <sup>(1)</sup>	MAX	UNIT		
V <sub>IK</sub>	Input diode clamp voltage	I <sub>I</sub> = -18 mA	2.3 V to 5.5 V	-1.2			V		
V <sub>PORR</sub>	Power-on reset voltage, V <sub>CC</sub> rising	V <sub>I</sub> = V <sub>CC</sub> or GND, I <sub>O</sub> = 0			1.2	1.5	V		
V <sub>PORF</sub>	Power-on reset voltage, V <sub>CC</sub> falling	V <sub>I</sub> = V <sub>CC</sub> or GND, I <sub>O</sub> = 0		0.75	1		V		
V <sub>OH</sub>	P-port high-level output voltage <sup>(2)</sup>	I <sub>OH</sub> = -8 mA	2.3 V	1.8			V		
			3 V	2.6					
			4.5 V	4.1					
			4.75 V	4.1					
		I <sub>OH</sub> = -10 mA	2.3 V	1.7					
			3 V	2.5					
			4.5 V	4					
			4.75 V	4					
I <sub>OL</sub>	SDA	V <sub>OL</sub> = 0.4 V	2.3 V to 5.5 V	3	8		mA		
	P port <sup>(3)</sup>	V <sub>OL</sub> = 0.5 V	2.3 V	8	10				
			3 V	8	14				
			4.5 V	8	17				
			4.75 V	8	35				
	P port <sup>(3)</sup>	V <sub>OL</sub> = 0.7 V	2.3 V	10	13				
			3 V	10	19				
			4.5 V	10	24				
			4.75 V	10	45				
	INT	V <sub>OL</sub> = 0.4 V	2.3 V to 5.5 V	3	10				
	I <sub>I</sub>	SCL, SDA	V <sub>I</sub> = V <sub>CC</sub> or GND	2.3 V to 5.5 V				±1	μA
		A0, A1, A2						±1	
I <sub>IH</sub>	P port	V <sub>I</sub> = V <sub>CC</sub>	2.3 V to 5.5 V			1	μA		
I <sub>IL</sub>	P port	V <sub>I</sub> = GND	2.3 V to 5.5 V			-1	μA		
I <sub>CC</sub>	Operating mode	V <sub>I</sub> = V <sub>CC</sub> or GND, I <sub>O</sub> = 0, I/O = inputs, f <sub>scl</sub> = 400 kHz	5.5 V		104	175	μA		
			3.6 V		50	90			
			2.7 V		20	65			
		V <sub>I</sub> = V <sub>CC</sub> or GND, I <sub>O</sub> = 0, I/O = inputs, f <sub>scl</sub> = 100 kHz	5.5 V		60	150			
			3.6 V		15	40			
			2.7 V		8	20			
	Standby mode	V <sub>I</sub> = GND, I <sub>O</sub> = 0, I/O = inputs, f <sub>scl</sub> = 0 kHz	5.5 V		1.5	8.7			
			3.6 V		0.9	4			
			2.7 V		0.6	3			
ΔI <sub>CC</sub>	Additional current in standby mode	One input at V <sub>CC</sub> - 0.6 V, Other inputs at V <sub>CC</sub> or GND	2.3 V to 5.5 V			1.5	mA		
		All LED I/Os at V <sub>I</sub> = 4.3 V, f <sub>scl</sub> = 0 kHz	5.5 V			4			
C <sub>i</sub>	SCL	V <sub>I</sub> = V <sub>CC</sub> or GND	2.3 V to 5.5 V		4	8	pF		
C <sub>io</sub>	SDA	V <sub>IO</sub> = V <sub>CC</sub> or GND	2.3 V to 5.5 V		5.5	9.5	pF		
	P port				8	9.5			

(1) All typical values are at nominal supply voltage (2.5-V, 3.3-V, or 5-V V<sub>CC</sub>) and T<sub>A</sub> = 25°C.

(2) The total current sourced by all I/Os must be limited to 85 mA.

(3) Each I/O must be externally limited to a maximum of 25 mA, and the P port (P7–P0) must be limited to a maximum current of 200 mA.

## 7.6 I<sup>2</sup>C Interface Timing Requirements

over operating free-air temperature range (unless otherwise noted) (see [Figure 8-1](#))

		STANDARD MODE I <sup>2</sup> C BUS		FAST MODE I <sup>2</sup> C BUS		UNIT	
		MIN	MAX	MIN	MAX		
$f_{scl}$	I <sup>2</sup> C clock frequency	0	100	0	400	kHz	
$t_{sch}$	I <sup>2</sup> C clock high time	4		0.6		μs	
$t_{scl}$	I <sup>2</sup> C clock low time	4.7		1.3		μs	
$t_{sp}$	I <sup>2</sup> C spike time		50		50	ns	
$t_{sds}$	I <sup>2</sup> C serial-data setup time	250		100		ns	
$t_{sdh}$	I <sup>2</sup> C serial-data hold time	0		0		ns	
$t_{icr}$	I <sup>2</sup> C input rise time		1000	$20 + 0.1C_b$ <sup>(1)</sup>	300	ns	
$t_{icf}$	I <sup>2</sup> C input fall time		300	$20 + 0.1C_b$ <sup>(1)</sup>	300	ns	
$t_{ocf}$	I <sup>2</sup> C output fall time	10-pF to 400-pF bus	300	$20 + 0.1C_b$ <sup>(1)</sup>	300	ns	
$t_{buf}$	I <sup>2</sup> C bus free time between stop and start	4.7		1.3		μs	
$t_{sts}$	I <sup>2</sup> C Start or repeated Start condition setup	4.7		0.6		μs	
$t_{sth}$	I <sup>2</sup> C Start or repeated Start condition hold	4		0.6		μs	
$t_{sps}$	I <sup>2</sup> C Stop condition setup	4		0.6		μs	
$t_{vd(data)}$	Valid data time	SCL low to SDA output valid	300	50		ns	
$t_{vd(ack)}$	Valid data time of ACK condition	ACK signal from SCL low to SDA (out) low	0.3	3.45	0.1	0.9	μs
$C_b$	I <sup>2</sup> C bus capacitive load		400		400	ns	

(1)  $C_b$  = total capacitive of one bus in pF

## 7.7 Switching Characteristics

over operating free-air temperature range (unless otherwise noted) (see [Figure 8-2](#) and [Figure 8-3](#))

PARAMETER	FROM (INPUT)	TO (OUTPUT)	STANDARD MODE I <sup>2</sup> C BUS		FAST MODE I <sup>2</sup> C BUS		UNIT
			MIN	MAX	MIN	MAX	
$t_{iv}$	Interrupt valid time	P port	INT	4	4	4	μs
$t_{ir}$	Interrupt reset delay time	SCL	INT	4	4	4	μs
$t_{pv}$	Output data valid	SCL	P7–P0	350	350	350	ns
$t_{ps}$	Input data setup time	P port	SCL	100	100	100	ns
$t_{ph}$	Input data hold time	P port	SCL	1	1	1	μs



## 7.8 Typical Characteristics

$T_A = 25^\circ\text{C}$  (unless otherwise noted)

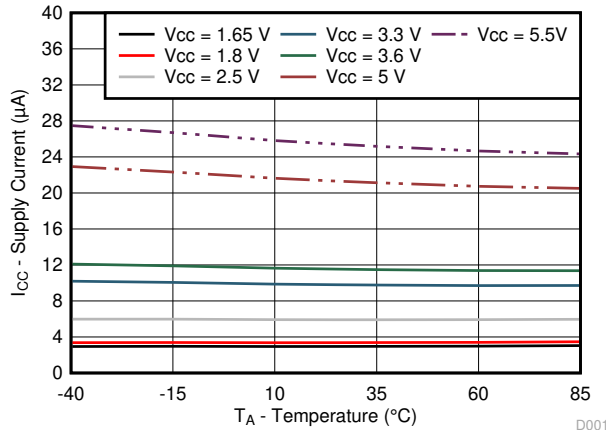

7-1. Supply Current vs Temperature for Different Supply Voltage ( $V_{CC}$ )

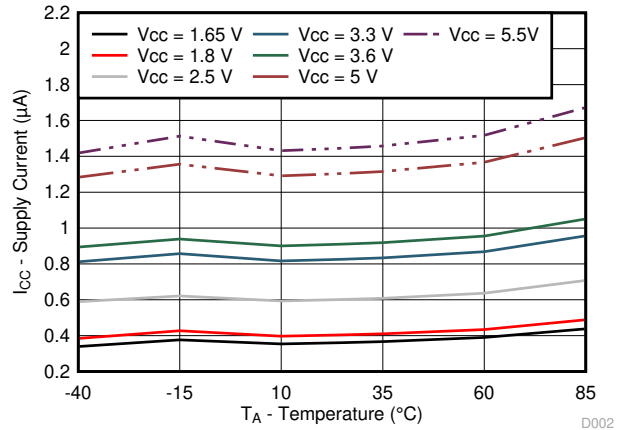

7-2. Standby Supply Current vs Temperature for Different Supply Voltage ( $V_{CC}$ )

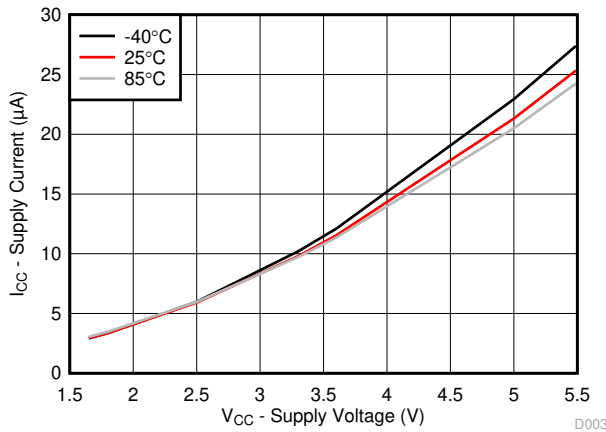

7-3. Supply Current vs Supply Voltage for Different Temperature ( $T_A$ )

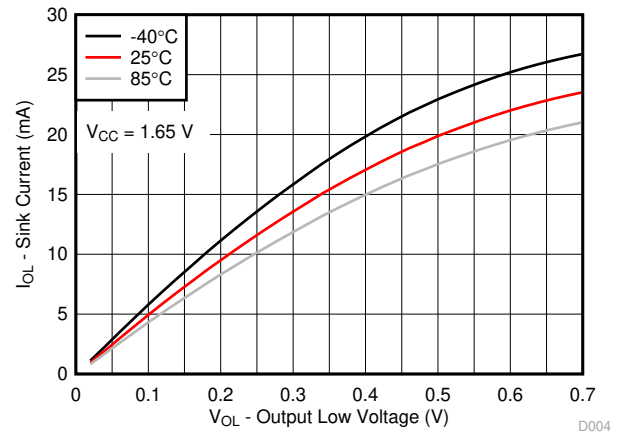

7-4. I/O Sink Current vs Output Low Voltage for Different Temperature ( $T_A$ ) for  $V_{CC} = 1.65\text{ V}$

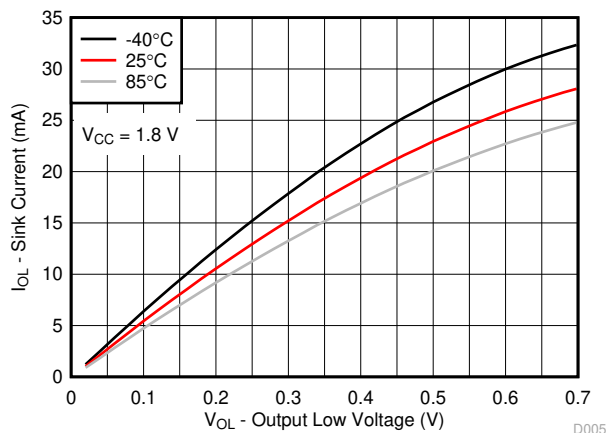

7-5. I/O Sink Current vs Output Low Voltage for Different Temperature ( $T_A$ ) for  $V_{CC} = 1.8\text{ V}$

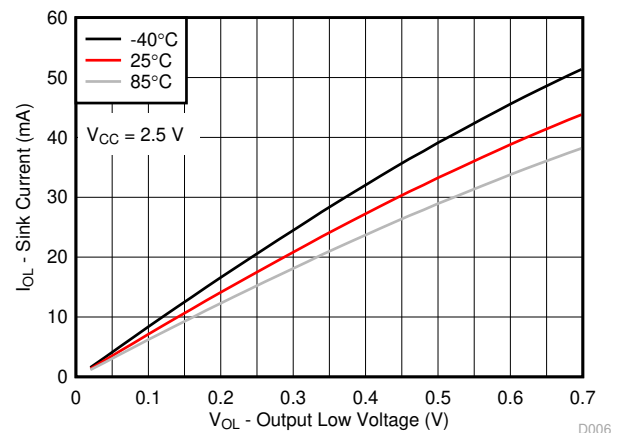

7-6. I/O Sink Current vs Output Low Voltage for Different Temperature ( $T_A$ ) for  $V_{CC} = 2.5\text{ V}$

### 7.8 Typical Characteristics (continued)

T<sub>A</sub> = 25°C (unless otherwise noted)

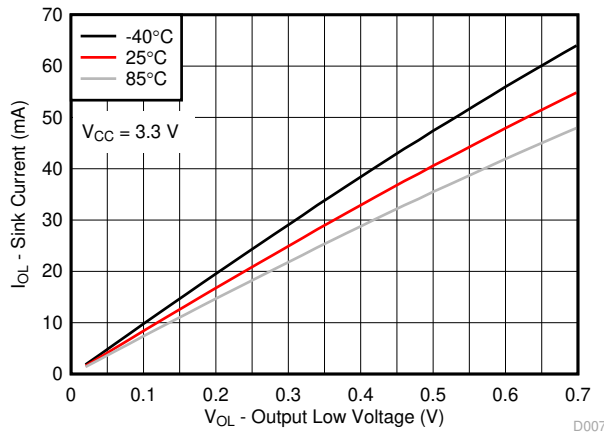

**7-7. I/O Sink Current vs Output Low Voltage for Different Temperature (T<sub>A</sub>) for V<sub>CC</sub> = 3.3 V**

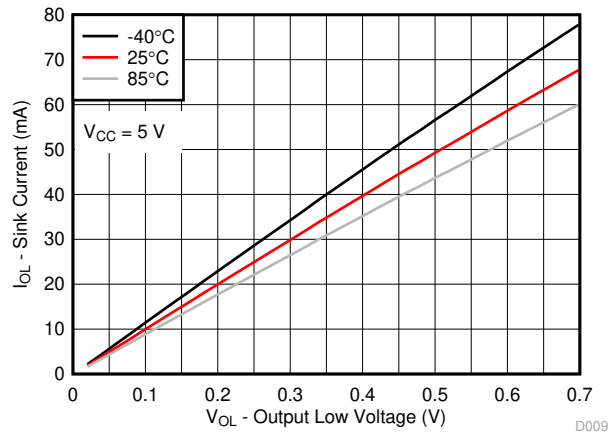

**7-8. I/O Sink Current vs Output Low Voltage for Different Temperature (T<sub>A</sub>) for V<sub>CC</sub> = 5 V**

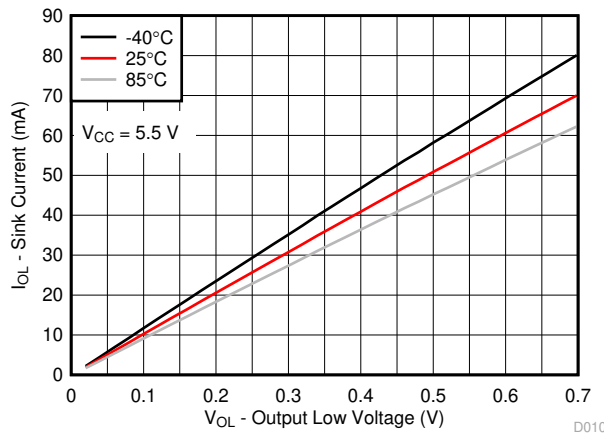

**7-9. I/O Sink Current vs Output Low Voltage for Different Temperature (T<sub>A</sub>) for V<sub>CC</sub> = 5.5 V**

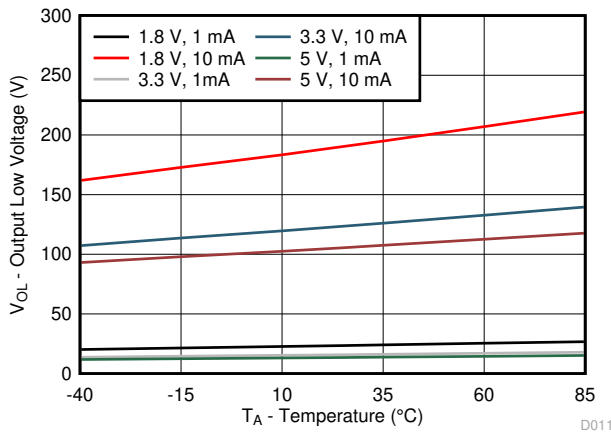

**7-10. I/O Low Voltage vs Temperature for Different V<sub>CC</sub> and I<sub>OL</sub>**

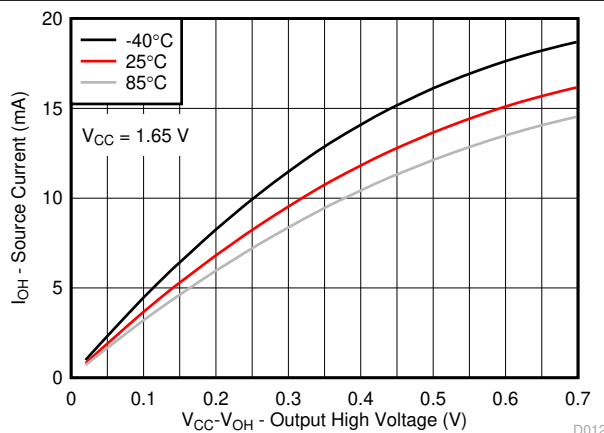

**7-11. I/O Source Current vs Output High Voltage for Different Temperature (T<sub>A</sub>) for V<sub>CC</sub> = 1.65 V**

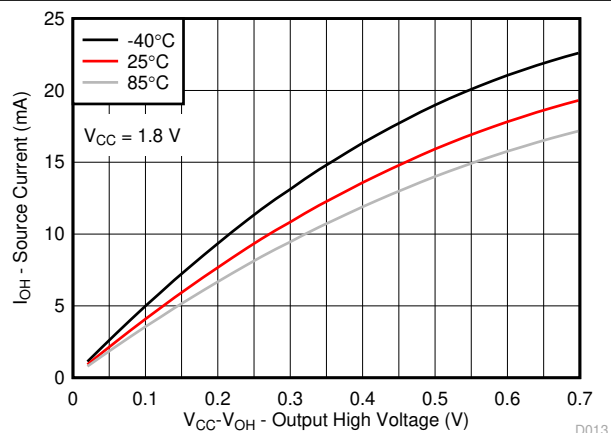

**7-12. I/O Source Current vs Output High Voltage for Different Temperature (T<sub>A</sub>) for V<sub>CC</sub> = 1.8 V**

## 7.8 Typical Characteristics (continued)

$T_A = 25^\circ\text{C}$  (unless otherwise noted)

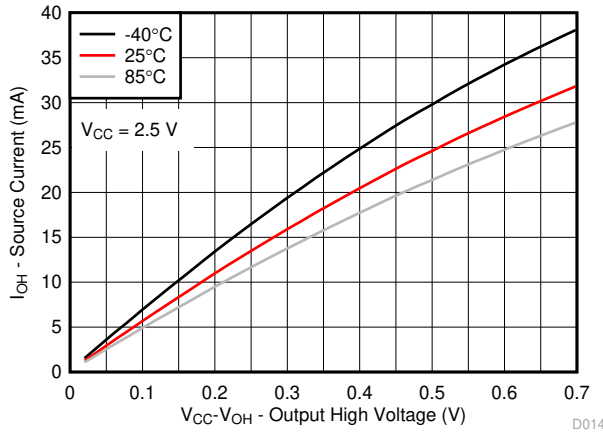

7-13. I/O Source Current vs Output High Voltage for Different Temperature ( $T_A$ ) for  $V_{CC} = 2.5\text{ V}$

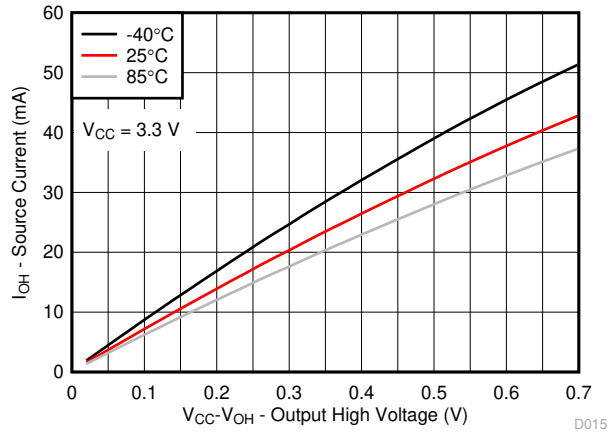

7-14. I/O Source Current vs Output High Voltage for Different Temperature ( $T_A$ ) for  $V_{CC} = 3.3\text{ V}$

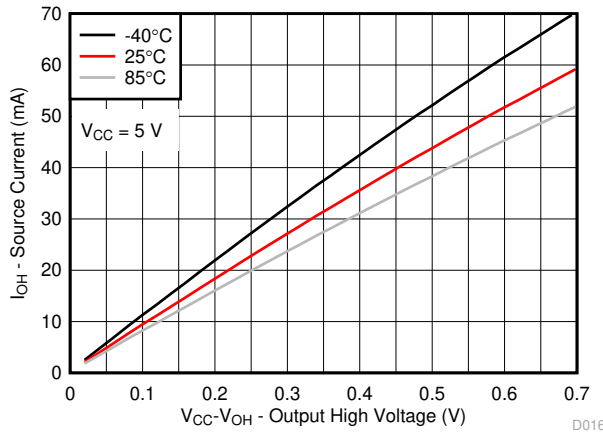

7-15. I/O Source Current vs Output High Voltage for Different Temperature ( $T_A$ ) for  $V_{CC} = 5\text{ V}$

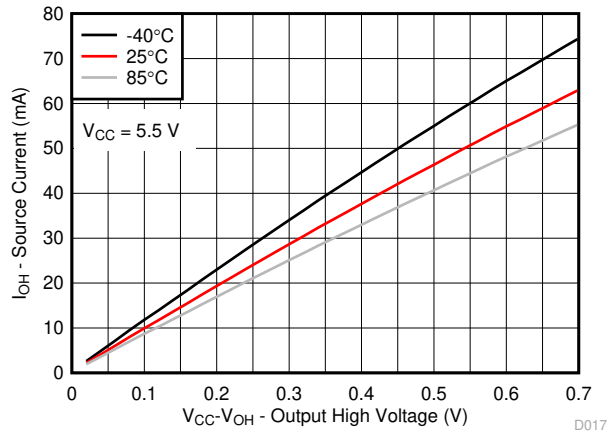

7-16. I/O Source Current vs Output High Voltage for Different Temperature ( $T_A$ ) for  $V_{CC} = 5.5\text{ V}$

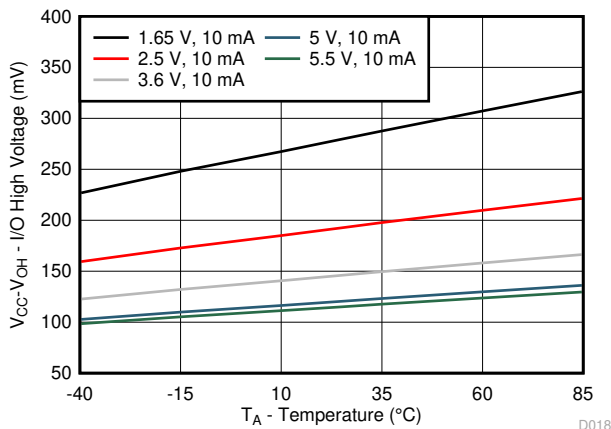

7-17.  $V_{CC} - V_{OH}$  Voltage vs Temperature for Different  $V_{CC}$

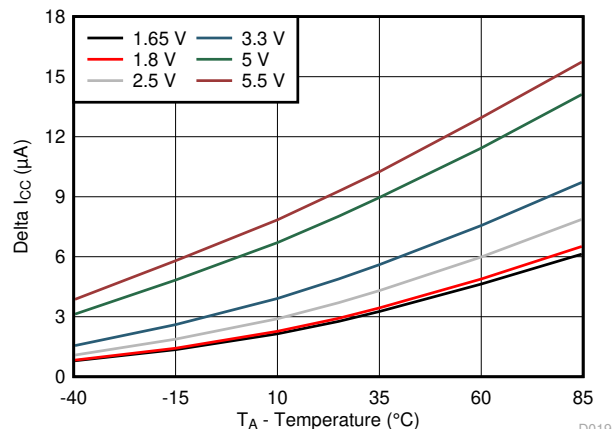

7-18.  $\Delta I_{CC}$  vs Temperature for Different  $V_{CC}$  ( $V_I = V_{CC} - 0.6\text{ V}$ )

## 8 Parameter Measurement Information

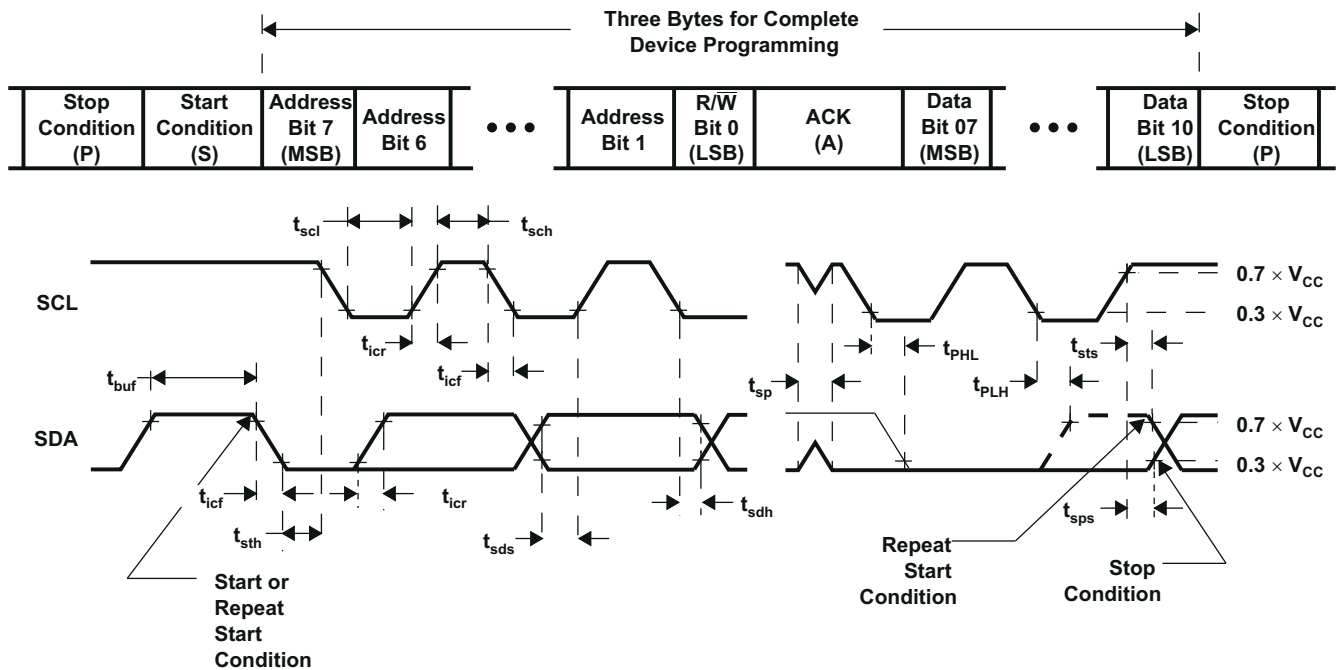
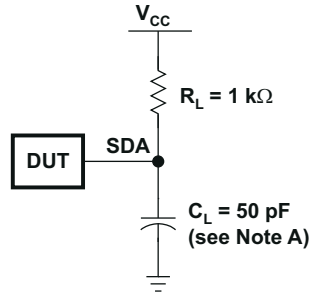

**VOLTAGE WAVEFORMS**

BYTE	DESCRIPTION
1	I <sup>2</sup> C address
2, 3	P-port data

- A.  $C_L$  includes probe and jig capacitance.
- B. All inputs are supplied by generators having the following characteristics:  $PRR \leq 10$  MHz,  $Z_O = 50 \Omega$ ,  $t_r/t_f \leq 30$  ns.
- C. All parameters and waveforms are not applicable to all devices.

**图 8-1. I<sup>2</sup>C Interface Load Circuit And Voltage Waveforms**



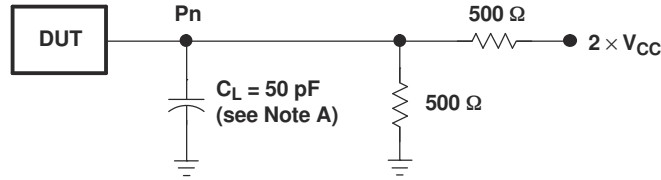

P-PORT LOAD CONFIGURATION

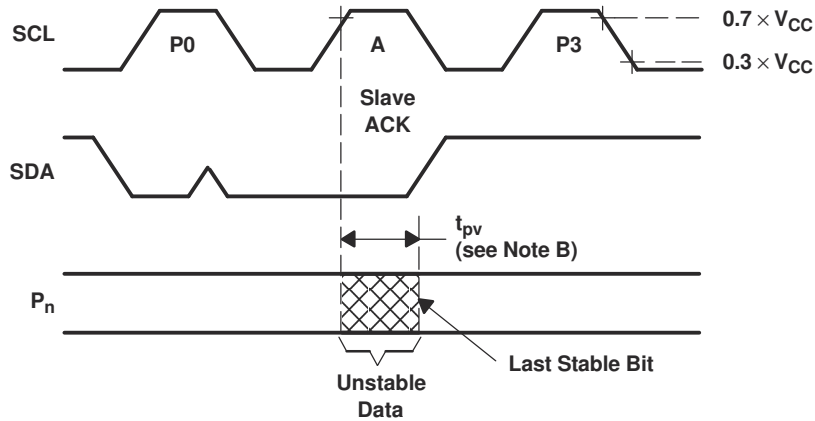

WRITE MODE ( $R/\bar{W} = 0$ )

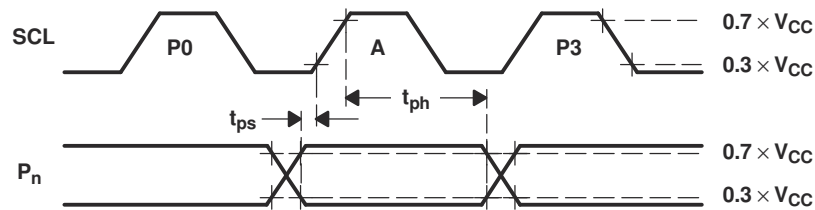

READ MODE ( $R/\bar{W} = 1$ )

- A.  $C_L$  includes probe and jig capacitance.
- B.  $t_{pv}$  is measured from  $0.7 \times V_{CC}$  on SCL to 50% I/O ( $P_n$ ) output.
- C. All inputs are supplied by generators having the following characteristics:  $PRR \leq 10$  MHz,  $Z_O = 50 \Omega$ ,  $t_r/t_f \leq 30$  ns.
- D. The outputs are measured one at a time, with one transition per measurement.
- E. All parameters and waveforms are not applicable to all devices.

**8-3. P-Port Load Circuit And Voltage Waveforms**

## 9 Detailed Description

### 9.1 Functional Block Diagram

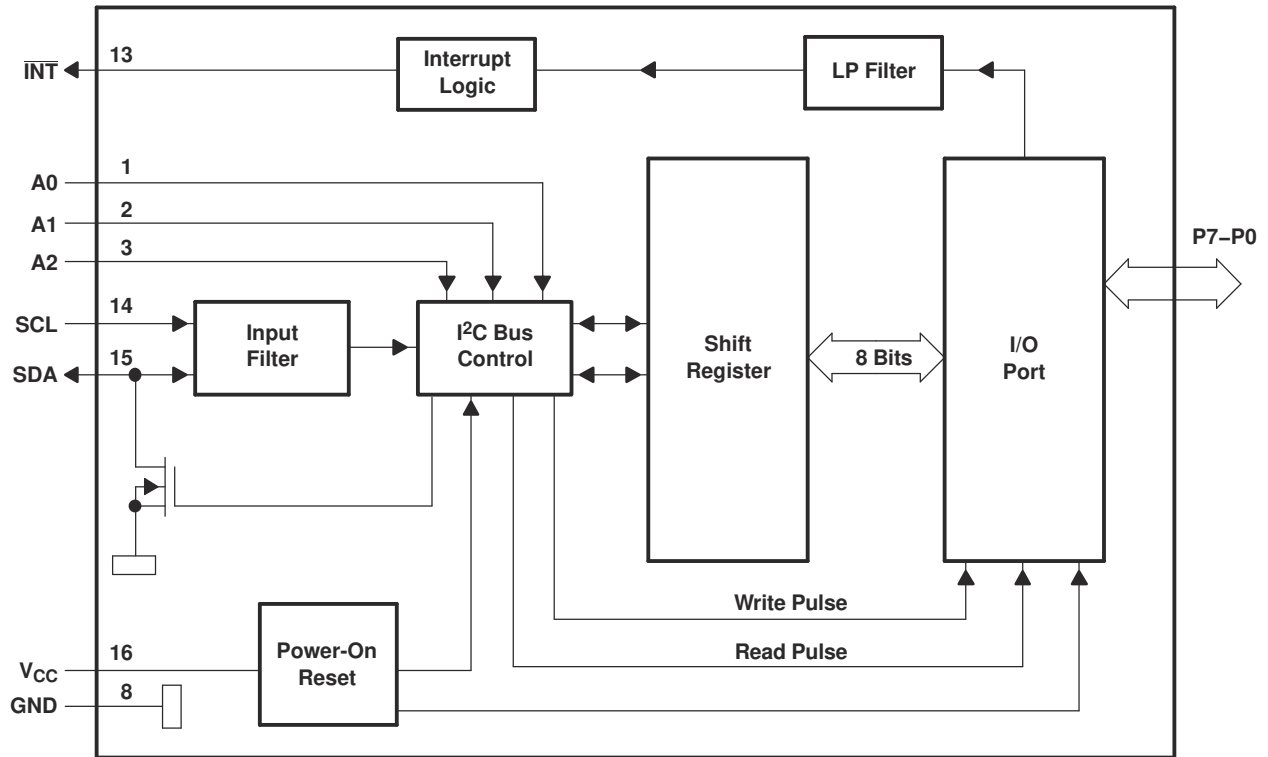

- A. Pin numbers shown are for DB, DGV, DW, or PW package.
- B. All I/Os are set to inputs at reset.

**9-1. Logic Diagram (Positive Logic)**

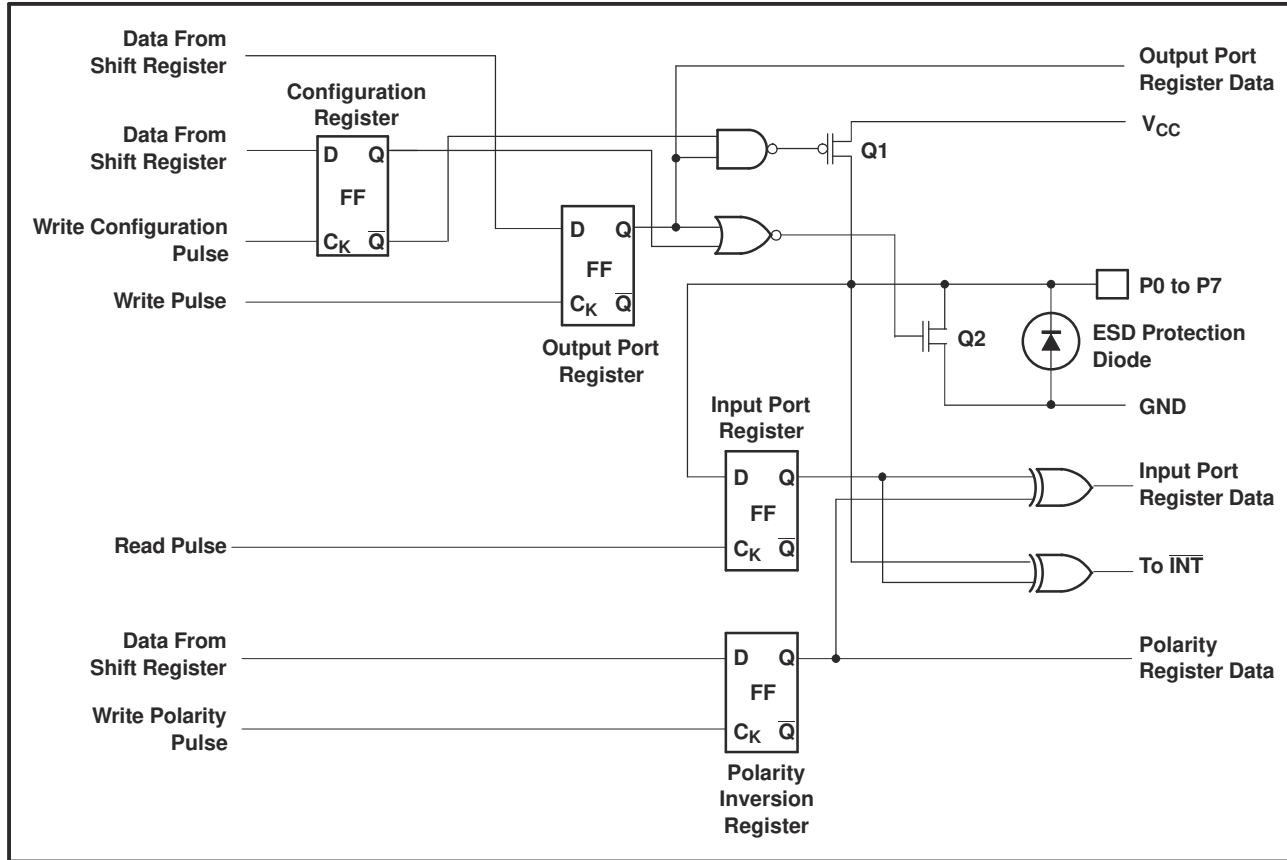

A. At power-on reset, all registers return to default values.

**9-2. Simplified Schematic of P0 to P7**

## 9.2 Device Functional Modes

### 9.2.1 Power-On Reset

When power (from 0 V) is applied to  $V_{CC}$ , an internal power-on reset holds the PCA9534 in a reset condition until  $V_{CC}$  has reached  $V_{POR}$ . At that point, the reset condition is released and the PCA9534 registers and I<sup>2</sup>C/SMBus state machine initialize to their default states. After that,  $V_{CC}$  must be lowered to below 0.2 V and then back up to the operating voltage for a power-reset cycle.

### 9.2.2 I/O Port

When an I/O is configured as an input, FETs Q1 and Q2 (in [9-2](#)) are off, creating a high-impedance input. The input voltage may be raised above  $V_{CC}$  to a maximum of 5.5 V.

If the I/O is configured as an output, Q1 or Q2 is enabled, depending on the state of the output port register. In this case, there are low-impedance paths between the I/O pin and either  $V_{CC}$  or GND. The external voltage applied to this I/O pin should not exceed the recommended levels for proper operation.

### 9.2.3 Interrupt Output ( $\overline{INT}$ )

An interrupt is generated by any rising or falling edge of the port inputs in the input mode. After time,  $t_{iv}$ , the signal  $\overline{INT}$  is valid. Resetting the interrupt circuit is achieved when data on the port is changed to the original setting, data is read from the port that generated the interrupt. Resetting occurs in the read mode at the acknowledge (ACK) or not acknowledge (NACK) bit after the rising edge of the SCL signal.

Interrupts that occur during the ACK or NACK clock pulse can be lost (or be very short) due to the resetting of the interrupt during this pulse. Each change of the I/Os after resetting is detected and is transmitted as  $\overline{INT}$ . Writing to another device does not affect the interrupt circuit, and a pin configured as an output cannot cause an



interrupt. Changing an I/O from an output to an input may cause a false interrupt to occur, if the state of the pin does not match the contents of the Input Port register. Because each 8-pin port is read independently, the interrupt caused by port 0 is not cleared by a read of port 1 or vice versa.

The  $\overline{\text{INT}}$  output has an open-drain structure and requires pullup resistor to  $V_{\text{CC}}$ .

### 9.2.3.1 Interrupt Errata

#### 9.2.3.1.1 Description

The INT will be improperly de-asserted if the following two conditions occur:

1. The last I<sup>2</sup>C command byte (register pointer) written to the device was 00h.

---

#### Note

This generally means the last operation with the device was a Read of the input register. However, the command byte may have been written with 00h without ever going on to read the input register. After reading from the device, if no other command byte written, it will remain 00h.

2. Any other slave device on the I<sup>2</sup>C bus acknowledges an address byte with the R/W bit set high

#### 9.2.3.1.2 System Impact

Can cause improper interrupt handling as the Master will see the interrupt as being cleared.

#### 9.2.3.1.3 System Workaround

Minor software change: User must change command byte to something besides 00h after a Read operation to the PCA9534 device or before reading from another slave device.

---

#### Note

Software change will be compatible with other versions (competition and TI redesigns) of this device.

## 9.3 Programming

### 9.3.1 I<sup>2</sup>C Interface

The bidirectional I<sup>2</sup>C bus consists of the serial clock (SCL) and serial data (SDA) lines. Both lines must be connected to a positive supply through a pullup resistor when connected to the output stages of a device. Data transfer may be initiated only when the bus is not busy.

I<sup>2</sup>C communication with this device is initiated by a master sending a Start condition, a high-to-low transition on the SDA input/output while the SCL input is high (see [Figure 9-3](#)). After the Start condition, the device address byte is sent, most significant bit (MSB) first, including the data direction bit (R/  $\overline{\text{W}}$ ).

After receiving the valid address byte, this device responds with an acknowledge (ACK), a low on the SDA input/output during the high of the ACK-related clock pulse. The address inputs (A0–A2) of the slave device must not be changed between the Start and Stop conditions.

On the I<sup>2</sup>C bus, only one data bit is transferred during each clock pulse. The data on the SDA line must remain stable during the high pulse of the clock period, as changes in the data line at this time are interpreted as control commands (Start or Stop) (see [Figure 9-4](#)).

A Stop condition, a low-to-high transition on the SDA input/output while the SCL input is high, is sent by the master (see [Figure 9-3](#)).

Any number of data bytes can be transferred from the transmitter to receiver between the Start and Stop conditions. Each byte of eight bits is followed by one ACK bit. The transmitter must release the SDA line before the receiver can send an ACK bit. The device that acknowledges must pull down the SDA line during the ACK clock pulse so that the SDA line is stable low during the high pulse of the ACK-related clock period (see [Figure 9-5](#)). When a slave receiver is addressed, it must generate an ACK after each byte is received. Similarly, the master must generate an ACK after each byte that it receives from the slave transmitter. Setup and hold times must be met to ensure proper operation.

A master receiver will signal an end of data to the slave transmitter by not generating an acknowledge (NACK) after the last byte has been clocked out of the slave. This is done by the master receiver by holding the SDA line high. In this event, the transmitter must release the data line to enable the master to generate a Stop condition.



图 9-3. Definition Of Start And Stop Conditions



图 9-4. Bit Transfer

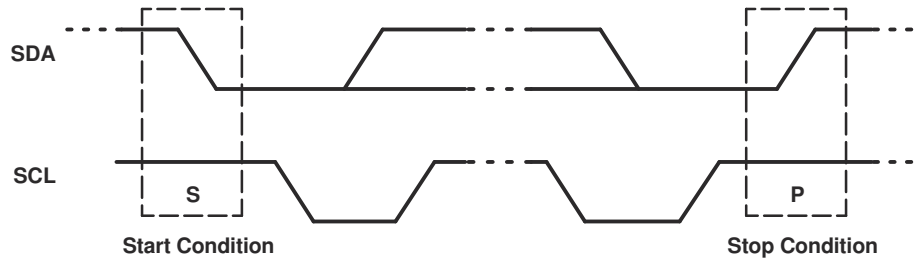

图 9-5. Acknowledgment On I<sup>2</sup>C Bus

### 9.3.2 Register Map

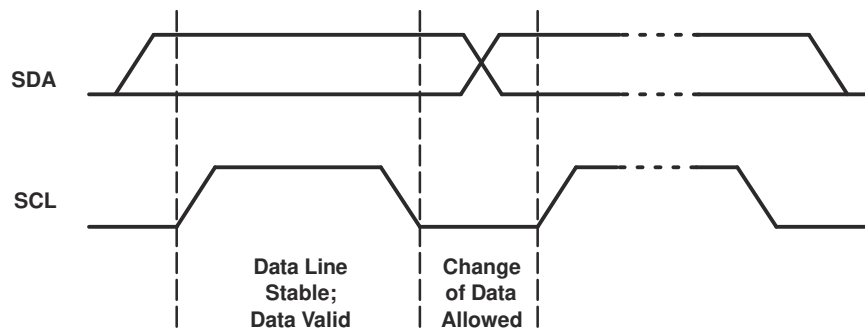
表 9-1. Interface Definition

BYTE	BIT							
	7 (MSB)	6	5	4	3	2	1	0 (LSB)
I <sup>2</sup> C slave address	L	H	L	L	A2	A1	A0	R/ W
Px I/O data bus	P7	P6	P5	P4	P3	P2	P1	P0

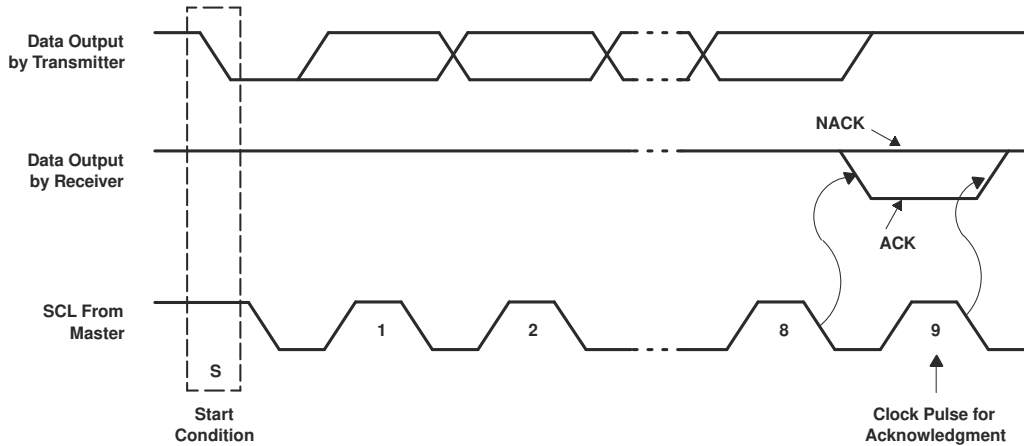
#### 9.3.2.1 Device Address

图 9-6 shows the address byte of the PCA9534.



图 9-6. Pca9534 Address

表 9-2. Address Reference

INPUTS			I <sup>2</sup> C BUS SLAVE ADDRESS
A2	A1	A0	
L	L	L	32 (decimal), 20 (hexadecimal)
L	L	H	33 (decimal), 21 (hexadecimal)
L	H	L	34 (decimal), 22 (hexadecimal)
L	H	H	35 (decimal), 23 (hexadecimal)
H	L	L	36 (decimal), 24 (hexadecimal)
H	L	H	37 (decimal), 25 (hexadecimal)
H	H	L	38 (decimal), 26 (hexadecimal)
H	H	H	39 (decimal), 27 (hexadecimal)

The last bit of the slave address defines the operation (read or write) to be performed. When it is high (1), a read is selected, while a low (0) selects a write operation.

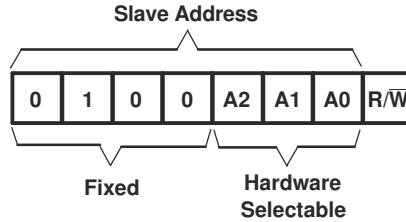
### 9.3.2.2 Control Register And Command Byte

Following the successful acknowledgment of the address byte, the bus master sends a command byte, which is stored in the control register in the PCA9534. Two bits of this command byte state the operation (read or write) and the internal register (input, output, polarity inversion or configuration) that will be affected. This register can be written or read through the I<sup>2</sup>C bus. The command byte is sent only during a write transmission.

Once a command byte has been sent, the register that was addressed continues to be accessed by reads until a new command byte has been sent.



图 9-7. Control Register Bits

表 9-3. Command Byte

CONTROL REGISTER BITS		COMMAND BYTE (HEX)	REGISTER	PROTOCOL	POWER-UP DEFAULT
B1	B0				
0	0	0x00	Input Port	Read byte	xxxx xxxx
0	1	0x01	Output Port	Read/write byte	1111 1111
1	0	0x02	Polarity Inversion	Read/write byte	0000 0000
1	1	0x03	Configuration	Read/write byte	1111 1111

### 9.3.2.3 Register Descriptions

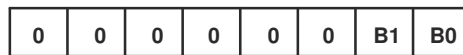
The Input Port register (register 0) reflects the incoming logic levels of the pins, regardless of whether the pin is defined as an input or an output by the Configuration register. It only acts on read operation. Writes to these registers have no effect. The default value, X, is determined by the externally applied logic level.

Before a read operation, a write transmission is sent with the command byte to let the I<sup>2</sup>C device know that the Input Port register will be accessed next.

**表 9-4. Register 0 (Input Port Register)**

BIT	I7	I6	I5	I4	I3	I2	I1	I0
DEFAULT	X	X	X	X	X	X	X	X

The Output Port register (register 1) shows the outgoing logic levels of the pins defined as outputs by the Configuration register. Bit values in this register have no effect on pins defined as inputs. In turn, reads from this register reflect the value that is in the flip-flop controlling the output selection, not the actual pin value.

**表 9-5. Register 1 (Output Port Register)**

BIT	O7	O6	O5	O4	O3	O2	O1	O0
DEFAULT	1	1	1	1	1	1	1	1

The Polarity Inversion register (register 2) allows polarity inversion of pins defined as inputs by the Configuration register. If a bit in this register is set (written with 1), the corresponding port pin polarity is inverted. If a bit in this register is cleared (written with a 0), the corresponding port pin original polarity is retained.

**表 9-6. Register 2 (Polarity Inversion Register)**

BIT	N7	N6	N5	N4	N3	N2	N1	N0
DEFAULT	0	0	0	0	0	0	0	0

The Configuration register (register 3) configures the directions of the I/O pins. If a bit in this register is set to 1, the corresponding port pin is enabled as an input with high-impedance output driver. If a bit in this register is cleared to 0, the corresponding port pin is enabled as an output.

**表 9-7. Register 3 (Configuration Register)**

BIT	C7	C6	C5	C4	C3	C2	C1	C0
DEFAULT	1	1	1	1	1	1	1	1

### 9.3.2.4 Bus Transactions

Data is exchanged between the master and PCA9534 through write and read commands.

#### 9.3.2.4.1 Writes

Data is transmitted to the PCA9534 by sending the device address and setting the least significant bit (LSB) to a logic 0 (see [图 9-6](#) for device address). The command byte is sent after the address and determines which register receives the data that follows the command byte (see [图 9-8](#) and [图 9-9](#)). There is no limitation on the number of data bytes sent in one write transmission.

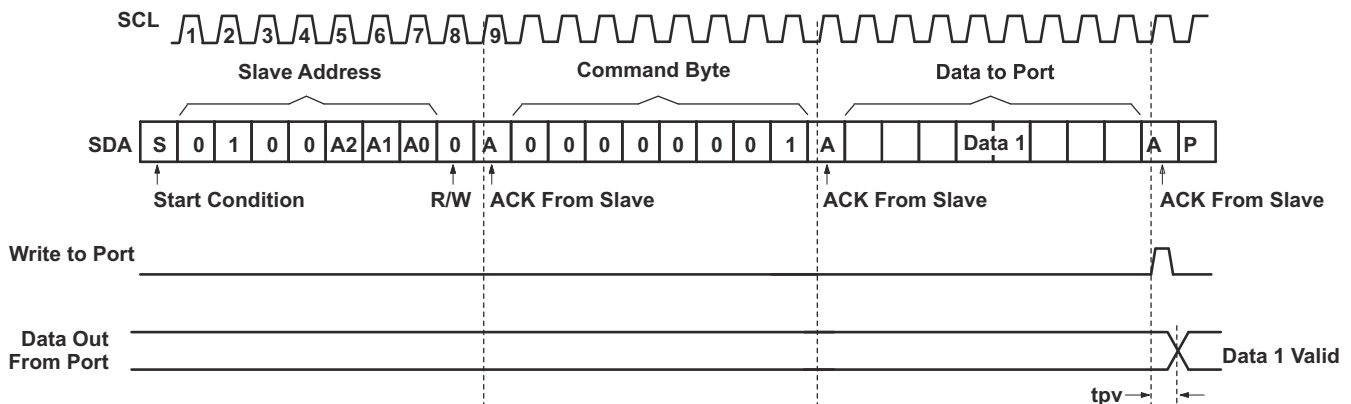

**图 9-8. Write To Output Port Register**

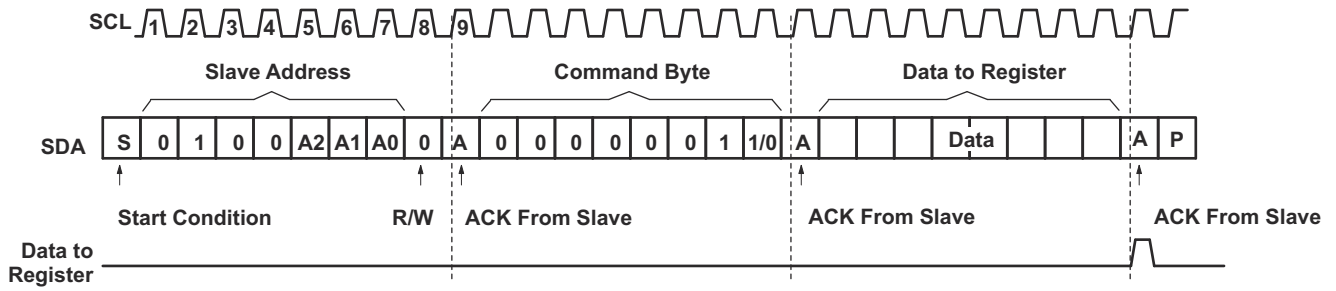

 **9-9. Write To Configuration Or Polarity Inversion Registers**

### 9.3.2.4.2 Reads

The bus master first must send the PCA9534 address with the LSB set to a logic 0 (see 9-6 for device address). The command byte is sent after the address and determines which register is accessed. After a restart, the device address is sent again but, this time, the LSB is set to a logic 1. Data from the register defined by the command byte then is sent by the PCA9534 (see 9-10 and 9-11). After a restart, the value of the register defined by the command byte matches the register being accessed when the restart occurred. Data is clocked into the register on the rising edge of the ACK clock pulse. There is no limitation on the number of data bytes received in one read transmission, but when the final byte is received, the bus master must not acknowledge the data.

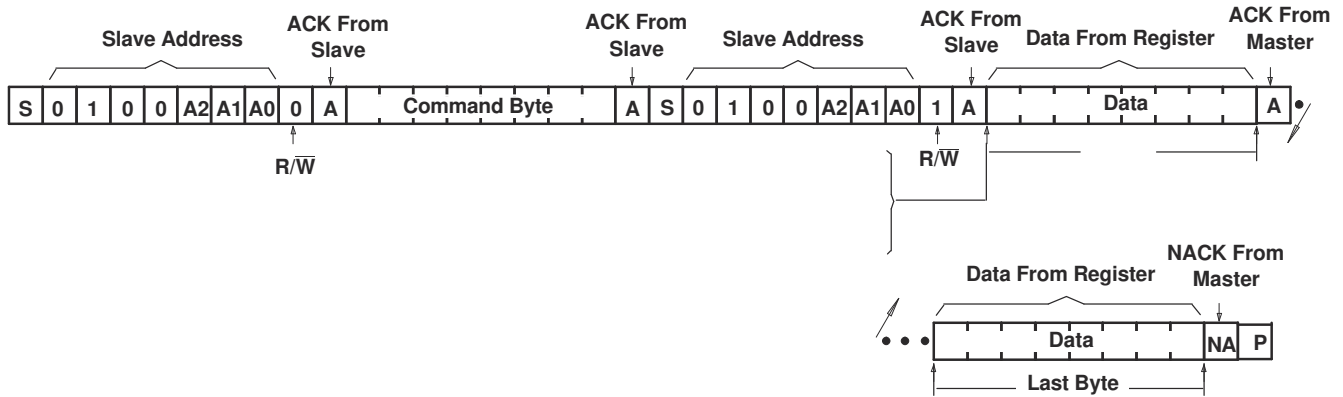

9-10. Read From Register

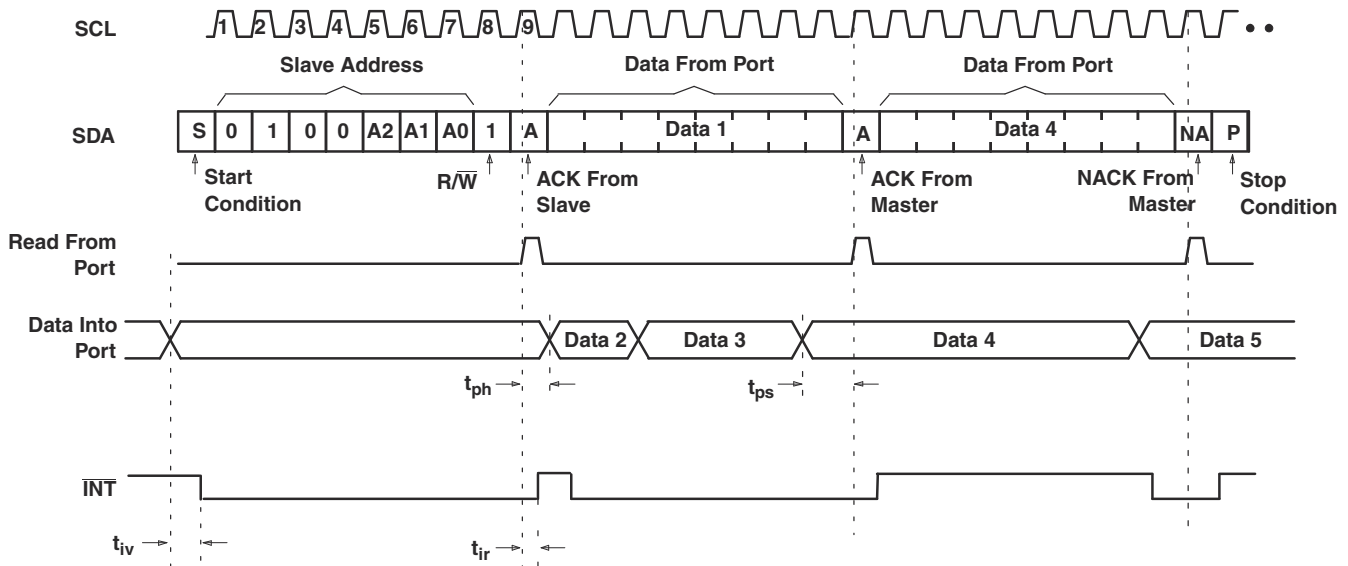

- A. This figure assumes that the command byte has previously been programmed with 00h.
- B. Transfer of data can be stopped at any moment by a Stop condition.
- C. This figure eliminates the command byte transfer, a restart and slave address call between the initial slave address call and the actual data transfer from the P Port. See 9-10 for these details.

9-11. Read Input Port Register

## 10 Application Information Disclaimer

### Note

Information in the following applications sections is not part of the TI component specification, and TI does not warrant its accuracy or completeness. TI's customers are responsible for determining suitability of components for their purposes, as well as validating and testing their design implementation to confirm system functionality.

## 10.1 Application Information

### 10.1.1 Typical Application

Figure 10-1 shows an application in which the PCA9534 can be used.

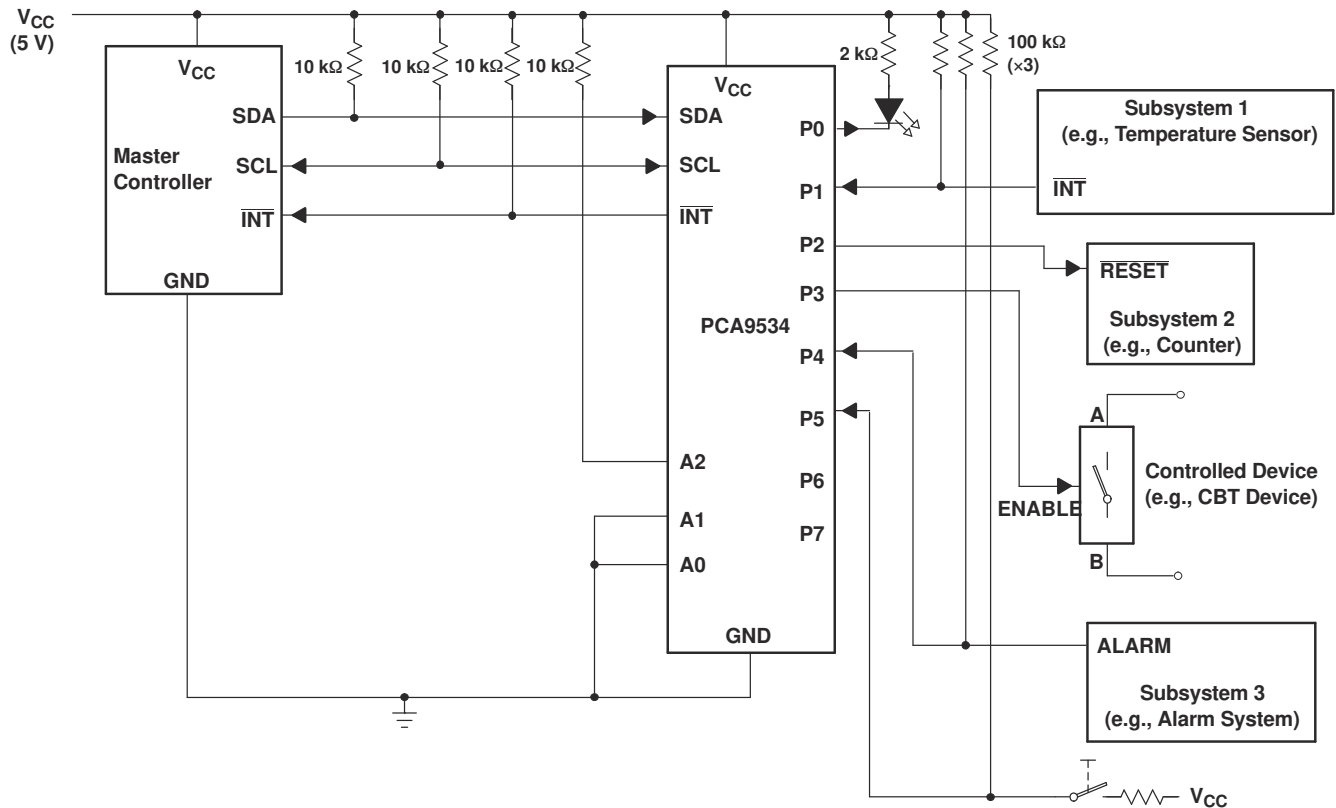

- A. Device address is configured as 0100100 for this example.
- B. P0, P2, and P3 are configured as outputs.
- C. P1, P4, and P5 are configured as inputs.
- D. P6 and P7 are not used and must be configured as outputs.

**Figure 10-1. Typical Application**

### 10.1.1.1 Design Requirements

#### 10.1.1.1.1 Minimizing $I_{CC}$ When The I/O Controls Leds

When the I/Os are used to control LEDs, they are normally connected to  $V_{CC}$  through a resistor, as shown in [Figure 10-1](#). Because the LED acts as a diode, when the LED is off, the I/O  $V_{IN}$  is about 1.2 V less than  $V_{CC}$ . The supply current,  $I_{CC}$ , increases as  $V_{IN}$  becomes lower than  $V_{CC}$  and is specified as  $\Delta I_{CC}$  in *Electrical Characteristics*.

For battery-powered applications, it is essential that the voltage of the I/O pins is greater than or equal to  $V_{CC}$  when the LED is off to minimize current consumption. [Figure 10-2](#) shows a high-value resistor in parallel with the LED. [Figure 10-3](#) shows  $V_{CC}$  less than the LED supply voltage by at least 1.2 V. Both of these methods maintain the I/O  $V_{IN}$  at or above  $V_{CC}$  and prevents additional supply-current consumption when the LED is off.

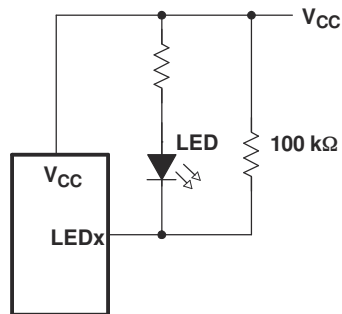

**Figure 10-2. High-Value Resistor In Parallel With The Led**

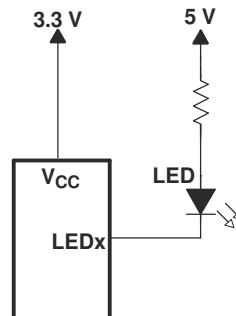

**Figure 10-3. Device Supplied By A Lower Voltage**



## 11 Power Supply Recommendations

### 11.1 Power-On Reset Requirements

In the event of a glitch or data corruption, PCA9534 can be reset to its default conditions by using the power-on reset feature. Power-on reset requires that the device go through a power cycle to be completely reset. This reset also happens when the device is powered on for the first time in an application.

The two types of power-on reset are shown in [Figure 11-1](#) and [Figure 11-2](#).

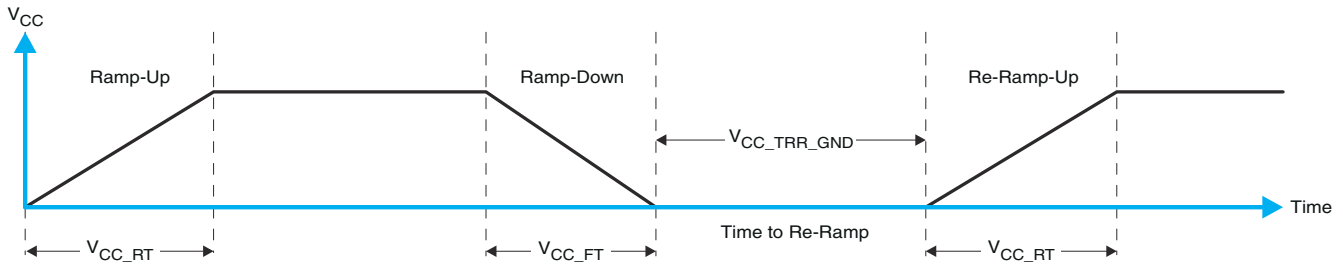

**Figure 11-1. V<sub>CC</sub> Is Lowered Below 0.2 V Or 0 V And Then Ramped Up To V<sub>CC</sub>**

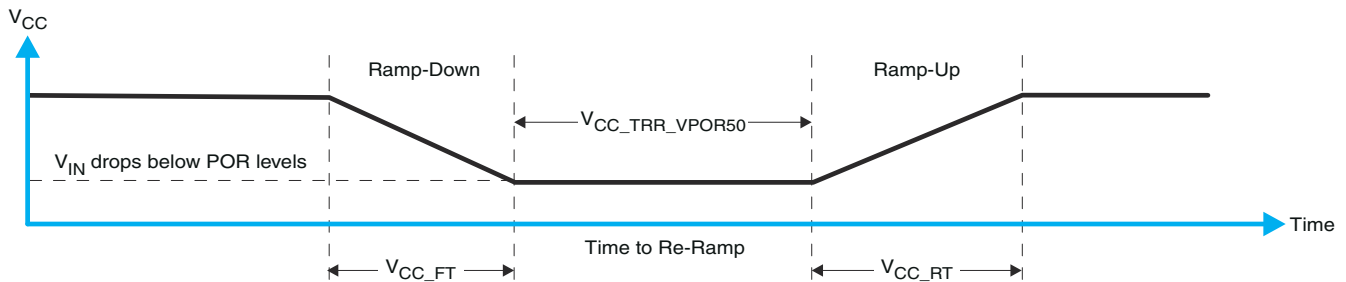

**Figure 11-2. V<sub>CC</sub> Is Lowered Below The Por Threshold, Then Ramped Back Up To V<sub>CC</sub>**

[Table 11-1](#) specifies the performance of the power-on reset feature for PCA9534 for both types of power-on reset.

**Table 11-1. Recommended Supply Sequencing And Ramp Rates<sup>(1)</sup>**

PARAMETER			MIN	TYP	MAX	UNIT
V <sub>CC_FT</sub>	Fall rate	See <a href="#">Figure 11-1</a>	1		100	ms
V <sub>CC_RT</sub>	Rise rate	See <a href="#">Figure 11-1</a>	0.01		100	ms
V <sub>CC_TRR_GND</sub>	Time to re-ramp (when V <sub>CC</sub> drops to GND)	See <a href="#">Figure 11-1</a>	0.001			ms
V <sub>CC_TRR_POR50</sub>	Time to re-ramp (when V <sub>CC</sub> drops to V <sub>POR_MIN</sub> – 50 mV)	See <a href="#">Figure 11-2</a>	0.001			ms
V <sub>CC_GH</sub>	Level that V <sub>CCP</sub> can glitch down to, but not cause a functional disruption when V <sub>CCX_GW</sub> = 1 μs	See <a href="#">Figure 11-3</a>			1.2	V
V <sub>CC_GW</sub>	Glitch width that will not cause a functional disruption when V <sub>CCX_GH</sub> = 0.5 × V <sub>CCx</sub>	See <a href="#">Figure 11-3</a>				μs
V <sub>PORF</sub>	Voltage trip point of POR on falling V <sub>CC</sub>		0.767		1.144	V
V <sub>PORR</sub>	Voltage trip point of POR on rising V <sub>CC</sub>		1.033		1.428	V

(1) T<sub>A</sub> = –40°C to 85°C (unless otherwise noted)

Glitches in the power supply can also affect the power-on reset performance of this device. The glitch width (V<sub>CC\_GW</sub>) and height (V<sub>CC\_GH</sub>) are dependent on each other. The bypass capacitance, source impedance, and the device impedance are factors that affect power-on reset performance. [Figure 11-3](#) and [Table 11-1](#) provide more information on how to measure these specifications.

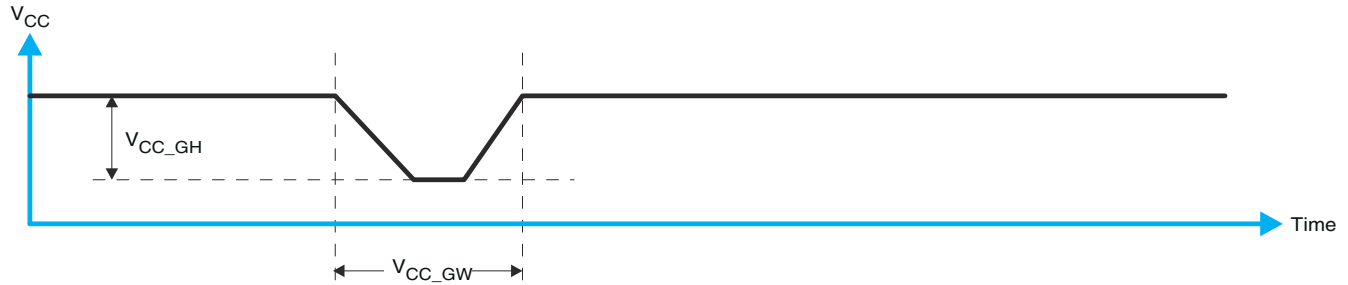

**FIG 11-3. Glitch Width And Glitch Height**

$V_{POR}$  is critical to the power-on reset.  $V_{POR}$  is the voltage level at which the reset condition is released and all the registers and the I<sup>2</sup>C/SMBus state machine are initialized to their default states. The value of  $V_{POR}$  differs based on the  $V_{CC}$  being lowered to or from 0. FIG 11-4 and 表 11-1 provide more details on this specification.

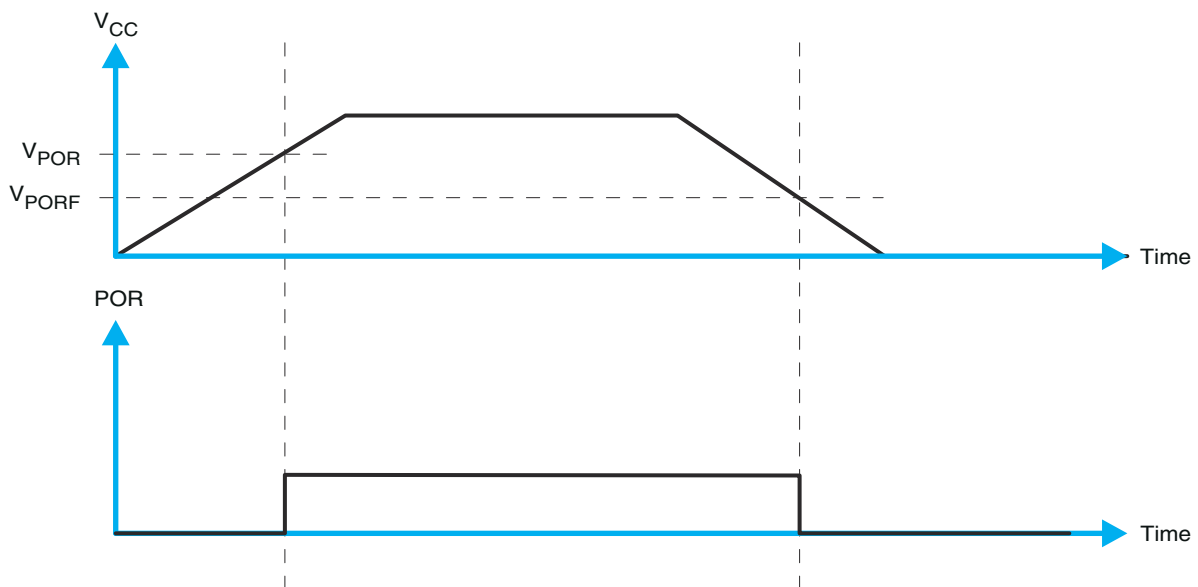

**FIG 11-4.  $V_{POR}$**

## 12 Device and Documentation Support

### 12.1 ドキュメントの更新通知を受け取る方法

ドキュメントの更新についての通知を受け取るには、[ti.com](http://ti.com) のデバイス製品フォルダを開いてください。「更新通知を受け取る」をクリックして登録すると、変更されたすべての製品情報の 1 週間分のダイジェストを受け取れます。変更の詳細については、修正されたドキュメントに含まれている改訂履歴をご覧ください。

### 12.2 サポート・リソース

TI E2E™ サポート・フォーラムは、検証済みの迅速な回答と設計支援をエンジニアがエキスパートから直接得るための頼れる情報源です。既存の回答を検索し、または新たに質問することで、必要とする設計支援を迅速に得ることができます。

リンクされているコンテンツは、該当する貢献者により、現状のまま提供されるものです。これらは TI の仕様を構成するものではなく、必ずしも TI の見解を反映したものではありません。TI の[使用条件](#)を参照してください。

### 12.3 Trademarks

TI E2E™ is a trademark of Texas Instruments.

すべての商標は、それぞれの所有者に帰属します。

### 12.4 静電気放電に関する注意事項



この IC は、ESD によって破損する可能性があります。テキサス・インスツルメンツは、IC を取り扱う際には常に適切な注意を払うことを推奨します。正しい ESD 対策をとらないと、デバイスを破損するおそれがあります。

ESD による破損は、わずかな性能低下からデバイスの完全な故障まで多岐にわたります。精密な IC の場合、パラメータがわずかに変化するだけで公表されている仕様から外れる可能性があるため、破損が発生しやすくなっています。

### 12.5 用語集

**TI 用語集** この用語集には、用語や略語の一覧および定義が記載されています。

## 13 Mechanical, Packaging, and Orderable Information

The following pages include mechanical, packaging, and orderable information. This information is the most current data available for the designated devices. This data is subject to change without notice and revision of this document. For browser-based versions of this data sheet, refer to the left-hand navigation.

**PACKAGING INFORMATION**

Orderable Device	Status (1)	Package Type	Package Drawing	Pins	Package Qty	Eco Plan (2)	Lead finish/ Ball material (6)	MSL Peak Temp (3)	Op Temp (°C)	Device Marking (4/5)	Samples
PCA9534DB	ACTIVE	SSOP	DB	16	80	RoHS & Green	NIPDAU	Level-1-260C-UNLIM	-40 to 85	PD534	<a href="#">Samples</a>
PCA9534DBR	ACTIVE	SSOP	DB	16	2000	RoHS & Green	NIPDAU	Level-1-260C-UNLIM	-40 to 85	PD534	<a href="#">Samples</a>
PCA9534DGVR	ACTIVE	TVSOP	DGV	16	2000	RoHS & Green	NIPDAU	Level-1-260C-UNLIM	-40 to 85	PD534	<a href="#">Samples</a>
PCA9534DW	OBSOLETE	SOIC	DW	16		TBD	Call TI	Call TI	-40 to 85	PCA9534	
PCA9534DWR	ACTIVE	SOIC	DW	16	2000	RoHS & Green	NIPDAU	Level-1-260C-UNLIM	-40 to 85	PCA9534	<a href="#">Samples</a>
PCA9534PW	OBSOLETE	TSSOP	PW	16		TBD	Call TI	Call TI	-40 to 85	PD534	
PCA9534PWR	ACTIVE	TSSOP	PW	16	2000	RoHS & Green	NIPDAU	Level-1-260C-UNLIM	-40 to 85	PD534	<a href="#">Samples</a>
PCA9534RGVR	ACTIVE	VQFN	RGV	16	2500	RoHS & Green	NIPDAU	Level-2-260C-1 YEAR	-40 to 85	PD534	<a href="#">Samples</a>

(1) The marketing status values are defined as follows:

**ACTIVE:** Product device recommended for new designs.

**LIFEBUY:** TI has announced that the device will be discontinued, and a lifetime-buy period is in effect.

**NRND:** Not recommended for new designs. Device is in production to support existing customers, but TI does not recommend using this part in a new design.

**PREVIEW:** Device has been announced but is not in production. Samples may or may not be available.

**OBSOLETE:** TI has discontinued the production of the device.

(2) **RoHS:** TI defines "RoHS" to mean semiconductor products that are compliant with the current EU RoHS requirements for all 10 RoHS substances, including the requirement that RoHS substance do not exceed 0.1% by weight in homogeneous materials. Where designed to be soldered at high temperatures, "RoHS" products are suitable for use in specified lead-free processes. TI may reference these types of products as "Pb-Free".

**RoHS Exempt:** TI defines "RoHS Exempt" to mean products that contain lead but are compliant with EU RoHS pursuant to a specific EU RoHS exemption.

**Green:** TI defines "Green" to mean the content of Chlorine (Cl) and Bromine (Br) based flame retardants meet JS709B low halogen requirements of <=1000ppm threshold. Antimony trioxide based flame retardants must also meet the <=1000ppm threshold requirement.

(3) MSL, Peak Temp. - The Moisture Sensitivity Level rating according to the JEDEC industry standard classifications, and peak solder temperature.

(4) There may be additional marking, which relates to the logo, the lot trace code information, or the environmental category on the device.

(5) Multiple Device Markings will be inside parentheses. Only one Device Marking contained in parentheses and separated by a "-" will appear on a device. If a line is indented then it is a continuation of the previous line and the two combined represent the entire Device Marking for that device.

<sup>(6)</sup> Lead finish/Ball material - Orderable Devices may have multiple material finish options. Finish options are separated by a vertical ruled line. Lead finish/Ball material values may wrap to two lines if the finish value exceeds the maximum column width.

**Important Information and Disclaimer:**The information provided on this page represents TI's knowledge and belief as of the date that it is provided. TI bases its knowledge and belief on information provided by third parties, and makes no representation or warranty as to the accuracy of such information. Efforts are underway to better integrate information from third parties. TI has taken and continues to take reasonable steps to provide representative and accurate information but may not have conducted destructive testing or chemical analysis on incoming materials and chemicals. TI and TI suppliers consider certain information to be proprietary, and thus CAS numbers and other limited information may not be available for release.

In no event shall TI's liability arising out of such information exceed the total purchase price of the TI part(s) at issue in this document sold by TI to Customer on an annual basis.

**TAPE AND REEL INFORMATION**

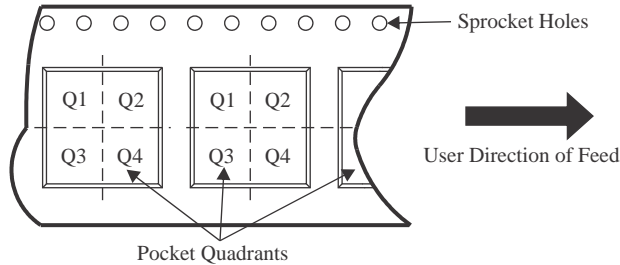
**QUADRANT ASSIGNMENTS FOR PIN 1 ORIENTATION IN TAPE**

\*All dimensions are nominal

Device	Package Type	Package Drawing	Pins	SPQ	Reel Diameter (mm)	Reel Width W1 (mm)	A0 (mm)	B0 (mm)	K0 (mm)	P1 (mm)	W (mm)	Pin1 Quadrant
PCA9534DBR	SSOP	DB	16	2000	330.0	16.4	8.35	6.6	2.4	12.0	16.0	Q1
PCA9534DGVR	TVSOP	DGV	16	2000	330.0	12.4	6.8	4.0	1.6	8.0	12.0	Q1
PCA9534DWR	SOIC	DW	16	2000	330.0	16.4	10.75	10.7	2.7	12.0	16.0	Q1
PCA9534PWR	TSSOP	PW	16	2000	330.0	12.4	6.9	5.6	1.6	8.0	12.0	Q1
PCA9534PWR	TSSOP	PW	16	2000	330.0	12.4	6.9	5.6	1.6	8.0	12.0	Q1
PCA9534RGVR	VQFN	RGV	16	2500	330.0	12.4	4.25	4.25	1.15	8.0	12.0	Q2

**TAPE AND REEL BOX DIMENSIONS**

\*All dimensions are nominal

Device	Package Type	Package Drawing	Pins	SPQ	Length (mm)	Width (mm)	Height (mm)
PCA9534DBR	SSOP	DB	16	2000	356.0	356.0	35.0
PCA9534DGVR	TVSOP	DGV	16	2000	356.0	356.0	35.0
PCA9534DWR	SOIC	DW	16	2000	350.0	350.0	43.0
PCA9534PWR	TSSOP	PW	16	2000	367.0	367.0	35.0
PCA9534PWR	TSSOP	PW	16	2000	356.0	356.0	35.0
PCA9534RGVR	VQFN	RGV	16	2500	367.0	367.0	35.0

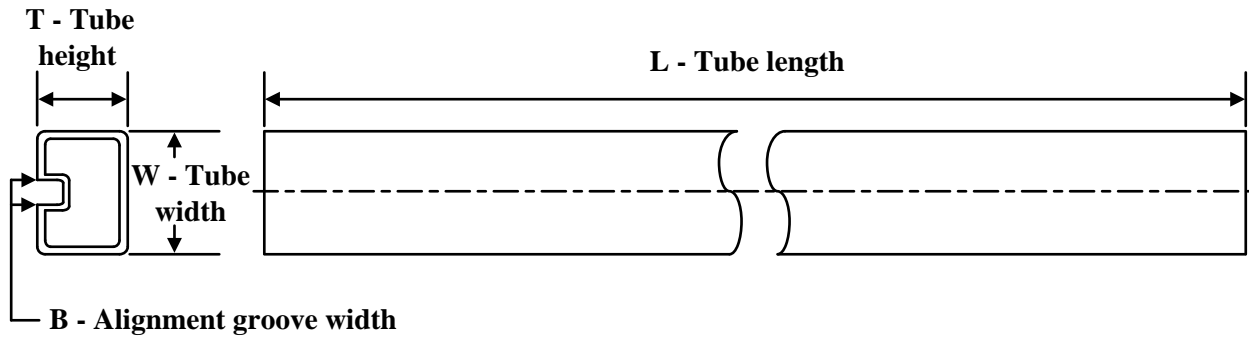
**TUBE**

\*All dimensions are nominal

Device	Package Name	Package Type	Pins	SPQ	L (mm)	W (mm)	T (μm)	B (mm)
PCA9534DB	DB	SSOP	16	80	530	10.5	4000	4.1



## GENERIC PACKAGE VIEW

**RGV 16**

**VQFN - 1 mm max height**

4 x 4, 0.65 mm pitch

PLASTIC QUAD FLATPACK - NO LEAD

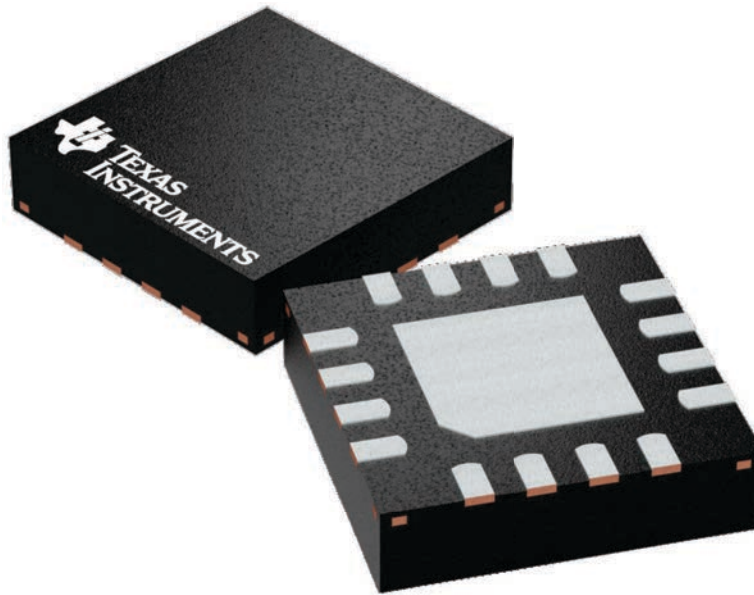

Images above are just a representation of the package family, actual package may vary.  
Refer to the product data sheet for package details.

4224748/A



# EXAMPLE BOARD LAYOUT

RGV0016A

VQFN - 1 mm max height

PLASTIC QUAD FLATPACK - NO LEAD

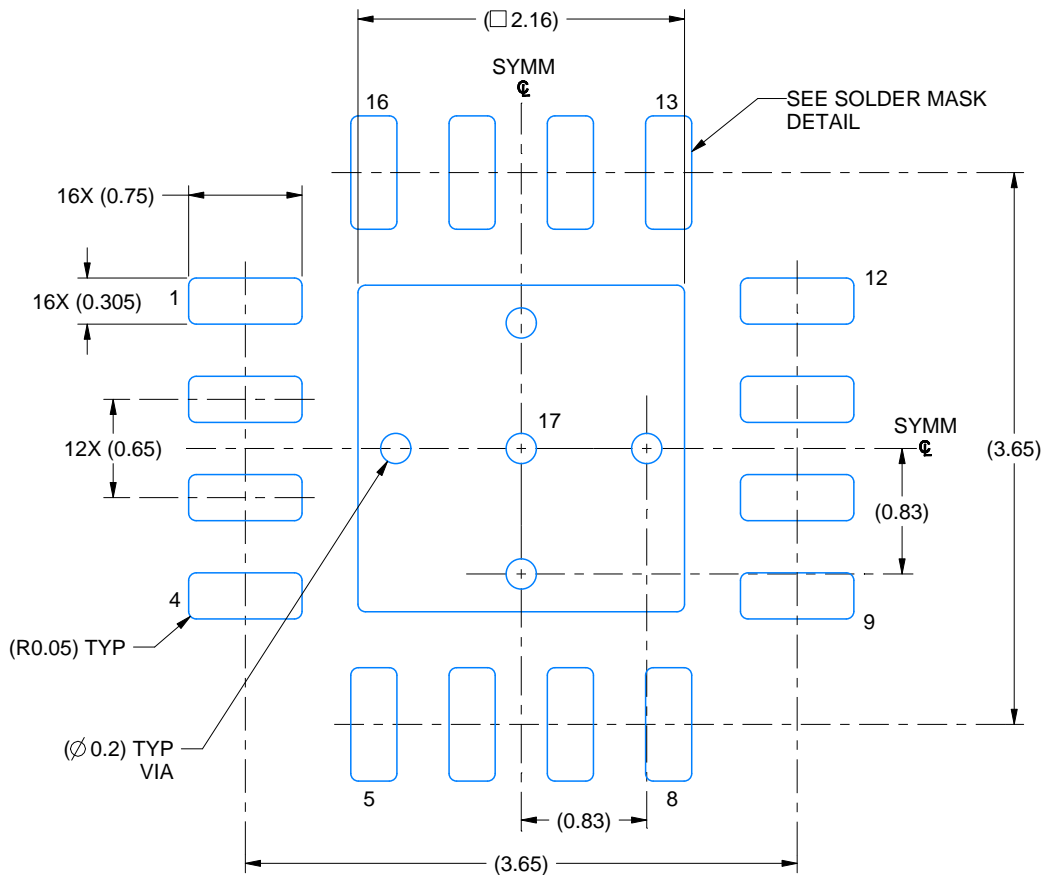

LAND PATTERN EXAMPLE  
EXPOSED METAL SHOWN  
SCALE: 20X



4219037/A 06/2019

NOTES: (continued)

- This package is designed to be soldered to a thermal pad on the board. For more information, see Texas Instruments literature number SLUA271 ([www.ti.com/lit/sl原因271](http://www.ti.com/lit/sl原因271)).
- Vias are optional depending on application, refer to device data sheet. If any vias are implemented, refer to their locations shown on this view. It is recommended that vias under paste be filled, plugged or tented.

# EXAMPLE STENCIL DESIGN

RGV0016A

VQFN - 1 mm max height

PLASTIC QUAD FLATPACK - NO LEAD

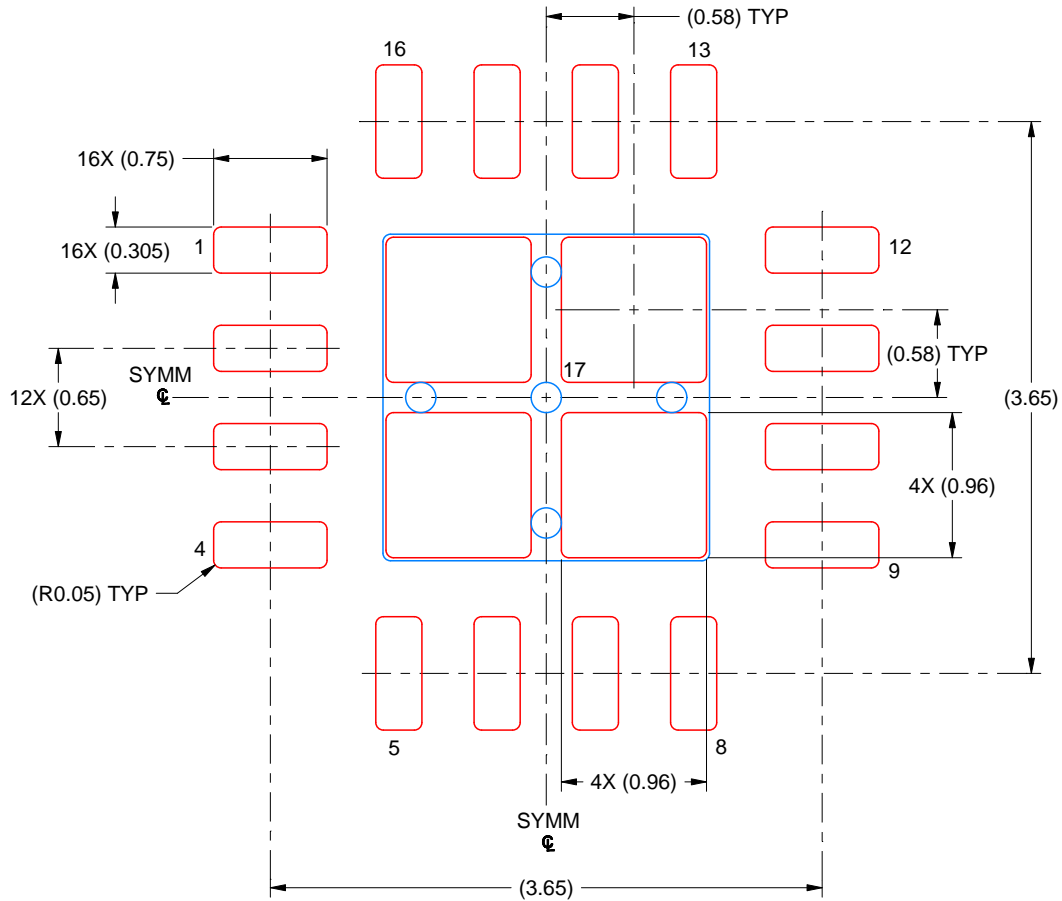

SOLDER PASTE EXAMPLE  
BASED ON 0.125 MM THICK STENCIL  
SCALE: 20X

EXPOSED PAD 17  
79% PRINTED SOLDER COVERAGE BY AREA UNDER PACKAGE

4219037/A 06/2019

NOTES: (continued)

6. Laser cutting apertures with trapezoidal walls and rounded corners may offer better paste release. IPC-7525 may have alternate design recommendations.



# EXAMPLE BOARD LAYOUT

PW0016A

TSSOP - 1.2 mm max height

SMALL OUTLINE PACKAGE



LAND PATTERN EXAMPLE  
EXPOSED METAL SHOWN  
SCALE: 10X



SOLDER MASK DETAILS

4220204/A 02/2017

NOTES: (continued)

- 6. Publication IPC-7351 may have alternate designs.
- 7. Solder mask tolerances between and around signal pads can vary based on board fabrication site.

# EXAMPLE STENCIL DESIGN

PW0016A

TSSOP - 1.2 mm max height

SMALL OUTLINE PACKAGE



SOLDER PASTE EXAMPLE  
BASED ON 0.125 mm THICK STENCIL  
SCALE: 10X

4220204/A 02/2017

NOTES: (continued)

8. Laser cutting apertures with trapezoidal walls and rounded corners may offer better paste release. IPC-7525 may have alternate design recommendations.
9. Board assembly site may have different recommendations for stencil design.

# DB0016A



# PACKAGE OUTLINE

## SSOP - 2 mm max height

SMALL OUTLINE PACKAGE



4220763/A 05/2022

### NOTES:

- All linear dimensions are in millimeters. Any dimensions in parenthesis are for reference only. Dimensioning and tolerancing per ASME Y14.5M.
- This drawing is subject to change without notice.
- This dimension does not include mold flash, protrusions, or gate burrs. Mold flash, protrusions, or gate burrs shall not exceed 0.15 mm per side.
- Reference JEDEC registration MO-150.



# EXAMPLE BOARD LAYOUT

DB0016A

SSOP - 2 mm max height

SMALL OUTLINE PACKAGE



LAND PATTERN EXAMPLE  
EXPOSED METAL SHOWN  
SCALE: 10X



4220763/A 05/2022

NOTES: (continued)

- 5. Publication IPC-7351 may have alternate designs.
- 6. Solder mask tolerances between and around signal pads can vary based on board fabrication site.

# EXAMPLE STENCIL DESIGN

DB0016A

SSOP - 2 mm max height

SMALL OUTLINE PACKAGE



SOLDER PASTE EXAMPLE  
BASED ON 0.125 mm THICK STENCIL  
SCALE: 10X

4220763/A 05/2022

NOTES: (continued)

7. Laser cutting apertures with trapezoidal walls and rounded corners may offer better paste release. IPC-7525 may have alternate design recommendations.
8. Board assembly site may have different recommendations for stencil design.

## GENERIC PACKAGE VIEW

**DW 16**

**SOIC - 2.65 mm max height**

7.5 x 10.3, 1.27 mm pitch

SMALL OUTLINE INTEGRATED CIRCUIT

This image is a representation of the package family, actual package may vary.  
Refer to the product data sheet for package details.



4224780/A



DW0016A

# PACKAGE OUTLINE

SOIC - 2.65 mm max height

SOIC

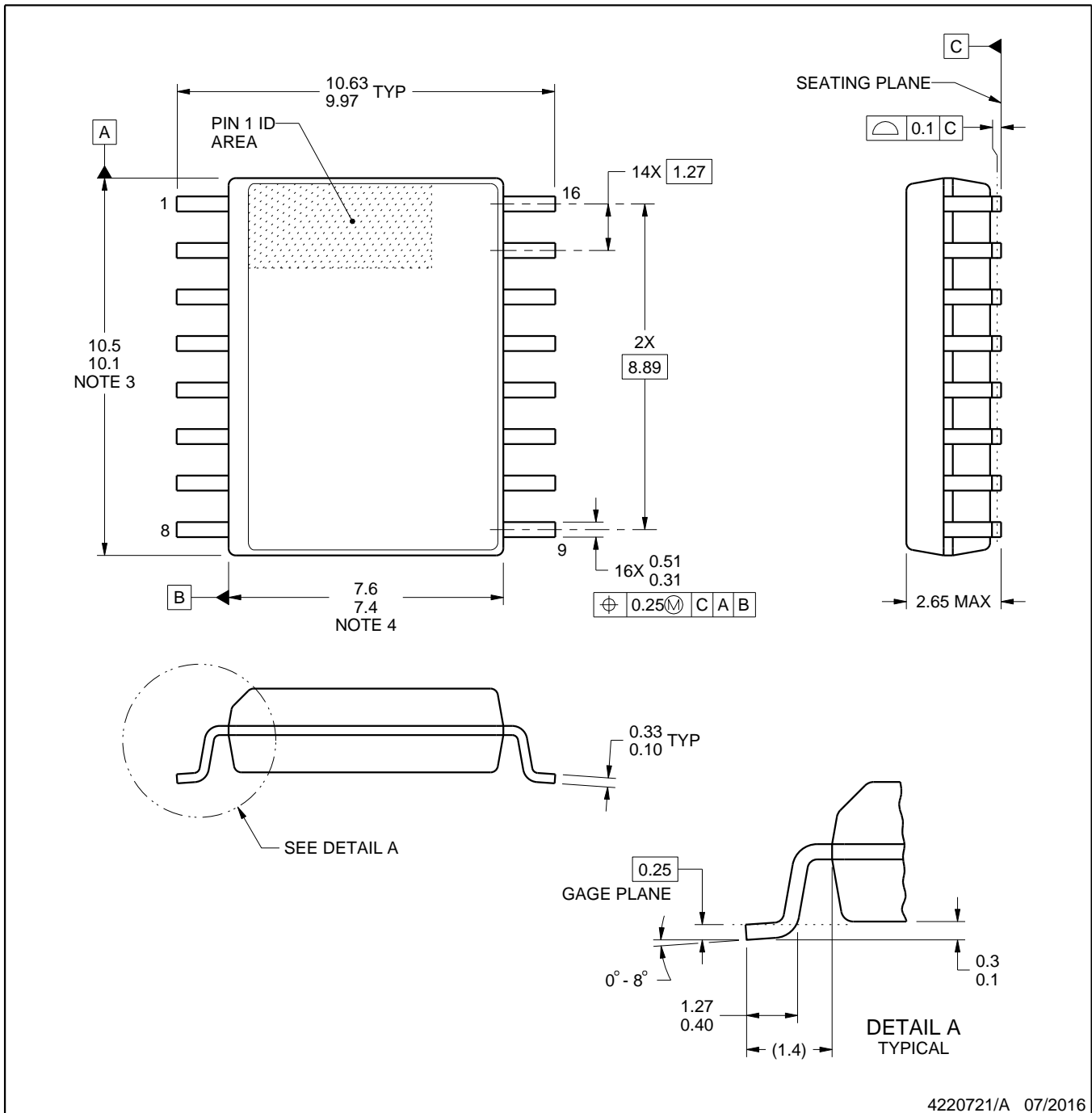

4220721/A 07/2016

## NOTES:

1. All linear dimensions are in millimeters. Dimensions in parenthesis are for reference only. Dimensioning and tolerancing per ASME Y14.5M.
2. This drawing is subject to change without notice.
3. This dimension does not include mold flash, protrusions, or gate burrs. Mold flash, protrusions, or gate burrs shall not exceed 0.15 mm, per side.
4. This dimension does not include interlead flash. Interlead flash shall not exceed 0.25 mm, per side.
5. Reference JEDEC registration MS-013.

# EXAMPLE BOARD LAYOUT

DW0016A

SOIC - 2.65 mm max height

SOIC



LAND PATTERN EXAMPLE  
SCALE:7X



SOLDER MASK DETAILS

4220721/A 07/2016

NOTES: (continued)

6. Publication IPC-7351 may have alternate designs.

7. Solder mask tolerances between and around signal pads can vary based on board fabrication site.

# EXAMPLE STENCIL DESIGN

DW0016A

SOIC - 2.65 mm max height

SOIC



SOLDER PASTE EXAMPLE  
BASED ON 0.125 mm THICK STENCIL  
SCALE:7X

4220721/A 07/2016

NOTES: (continued)

8. Laser cutting apertures with trapezoidal walls and rounded corners may offer better paste release. IPC-7525 may have alternate design recommendations.
9. Board assembly site may have different recommendations for stencil design.

## 重要なお知らせと免責事項

TI は、技術データと信頼性データ(データシートを含みます)、設計リソース(リファレンス・デザインを含みます)、アプリケーションや設計に関する各種アドバイス、Web ツール、安全性情報、その他のリソースを、欠陥が存在する可能性のある「現状のまま」提供しており、商品性および特定目的に対する適合性の黙示保証、第三者の知的財産権の非侵害保証を含むいかなる保証も、明示的または黙示的にかかわらず拒否します。

これらのリソースは、TI 製品を使用する設計の経験を積んだ開発者への提供を意図したものです。(1) お客様のアプリケーションに適した TI 製品の選定、(2) お客様のアプリケーションの設計、検証、試験、(3) お客様のアプリケーションに該当する各種規格や、その他のあらゆる安全性、セキュリティ、規制、または他の要件への確実な適合に関する責任を、お客様のみが単独で負うものとし、

上記の各種リソースは、予告なく変更される可能性があります。これらのリソースは、リソースで説明されている TI 製品を使用するアプリケーションの開発の目的でのみ、TI はその使用をお客様に許諾します。これらのリソースに関して、他の目的で複製することや掲載することは禁止されています。TI や第三者の知的財産権のライセンスが付与されている訳ではありません。お客様は、これらのリソースを自身で使用した結果発生するあらゆる申し立て、損害、費用、損失、責任について、TI およびその代理人を完全に補償するものとし、TI は一切の責任を拒否します。

TI の製品は、[TI の販売条件](#)、または [ti.com](#) やかかる TI 製品の関連資料などのいずれかを通じて提供する適用可能な条項の下で提供されています。TI がこれらのリソースを提供することは、適用される TI の保証または他の保証の放棄の拡大や変更を意味するものではありません。

お客様がいかなる追加条項または代替条項を提案した場合でも、TI はそれらに異議を唱え、拒否します。

郵送先住所 : Texas Instruments, Post Office Box 655303, Dallas, Texas 75265  
Copyright © 2024, Texas Instruments Incorporated