

## SNx4AC32 クワッド 2 入力正論理 OR ゲート

### 1 特長

- 2V~6V の  $V_{CC}$  で動作
- 6V までの入力電圧に対応
- 最大  $t_{pd}$  7.5ns (5V 時)

### 2 概要

'AC32 デバイスは、クワッド 2 入力正論理 OR ゲートです。デバイスは、ブール関数  $Y = A + B$  つまり、 $Y = \bar{A} \cdot \bar{B}$  を正論理で実行します。

#### 製品情報

部品番号	パッケージ (1)	パッケージサイズ (2)	本体サイズ (3)
SNx4AC32	DB (SSOP, 14)	6.2mm × 7.8mm	6.2mm × 5.3mm
	D (SOIC, 14)	8.65mm × 6mm	8.65mm × 3.9mm
	N (PDIP, 14)	19.3mm × 9.4mm	19.3mm × 6.35mm
	NS (SO, 14)	10.2mm × 7.8mm	10.3mm × 5.3mm
	PW (TSSOP, 14)	5mm × 6.4mm	5mm × 4.4mm

- (1) 詳細については、[セクション 10](#) を参照してください。
- (2) パッケージサイズ (長さ × 幅) は公称値であり、該当する場合はピンも含まれます。
- (3) 本体サイズ (長さ × 幅) は公称値であり、ピンは含まれません。



各ゲートの論理図 (正論理)



## Table of Contents

<b>1 特長</b> .....	1	6.2 Device Functional Modes.....	8
<b>2 概要</b> .....	1	<b>7 Application and Implementation</b> .....	9
<b>3 Pin Configuration and Functions</b> .....	3	7.1 Power Supply Recommendations.....	9
<b>4 Specifications</b> .....	4	7.2 Layout.....	9
4.1 Absolute Maximum Ratings.....	4	<b>8 Device and Documentation Support</b> .....	10
4.2 Recommended Operating Conditions.....	4	8.1 Documentation Support (Analog).....	10
4.3 Thermal Information.....	5	8.2 ドキュメントの更新通知を受け取る方法.....	10
4.4 Electrical Characteristics.....	5	8.3 サポート・リソース.....	10
4.5 Switching Characteristics, $V_{CC} = 3.3\text{ V} \pm 0.3\text{ V}$ .....	5	8.4 Trademarks.....	10
4.6 Switching Characteristics, $V_{CC} = 5\text{ V} \pm 0.5\text{ V}$ .....	6	8.5 静電気放電に関する注意事項.....	10
4.7 Operating Characteristics.....	6	8.6 用語集.....	10
<b>5 Parameter Measurement Information</b> .....	7	<b>9 Revision History</b> .....	10
<b>6 Detailed Description</b> .....	8	<b>10 Mechanical, Packaging, and Orderable Information</b> .....	11
6.1 Functional Block Diagram.....	8		

### 3 Pin Configuration and Functions



図 3-1. SN54AC32 J or W Package; SN74AC32 D, DB, N, NS, or PW Package (Top View)



NC – No internal connection

図 3-2. SN54AC32 FK Package (Top View)

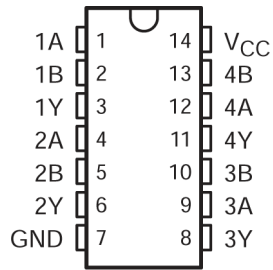
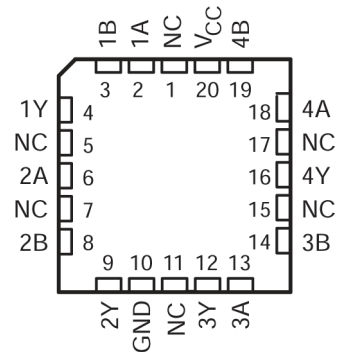
表 3-1. Pin Functions

NAME	PIN			TYPE <sup>(1)</sup>	DESCRIPTION
	SN74AC32 D, DB, DGV, N, NS, PW, RGY, BQA	SN54AC32 J, W	FK		
1A	1	1	2	I	1A Input
1B	2	23	3	I	1B Input
1Y	3	3	4	O	1Y Output
2A	4	4	6	I	2A Input
2B	5	5	8	I	2B Input
2Y	6	6	9	O	2Y Output
3A	9	9	13	I	3A Input
3B	10	10	14	I	3B Input
3Y	8	8	12	O	3Y Output
4A	12	12	18	I	4A Input
4B	13	13	19	I	4B Input
4Y	11	11	16	O	4Y Output
GND	7	7	10	—	Ground Pin
NC	—	—	1, 5, 7, 11, 15, 17	—	No Connection
V <sub>CC</sub>	14	14	20	—	Power Pin
Thermal Pad <sup>(2)</sup>	—	—	—	—	Thermal Pad

(1) Signal Types: I = Input, O = Output, I/O = Input or Output.

(2) RGY and BQA Package Only

## 4 Specifications

### 4.1 Absolute Maximum Ratings

over operating free-air temperature range (unless otherwise noted)<sup>(1)</sup>

		MIN	MAX	UNIT
$V_{CC}$	Supply voltage range	-0.5	7	V
$V_I$ <sup>(2)</sup>	Input voltage range	-0.5	$V_{CC} + 0.5$	V
$V_O$ <sup>(2)</sup>	Output voltage range	-0.5	$V_{CC} + 0.5$	V
$I_{IK}$	Input clamp current	$(V_I < 0 \text{ or } V_I > V_{CC})$		$\pm 20$ mA
$I_{OK}$	Output clamp current	$(V_O < 0 \text{ or } V_O > V_{CC})$		$\pm 20$ mA
$I_O$	Continuous output current	$(V_O = 0 \text{ to } V_{CC})$		$\pm 50$ mA
$I_O$	Continuous current through $V_{CC}$ or GND			$\pm 200$ mA
$T_{stg}$	Storage temperature range	-65	150	°C

- (1) Stresses beyond those listed under “absolute maximum ratings” may cause permanent damage to the device. These are stress ratings only, and functional operation of the device at these or any other conditions beyond those indicated under “recommended operating conditions” is not implied. Exposure to absolute-maximum-rated conditions for extended periods may affect device reliability.
- (2) The input and output voltage ratings may be exceeded if the input and output current ratings are observed.

### 4.2 Recommended Operating Conditions

over recommended operating free-air temperature range (unless otherwise noted)<sup>(1)</sup>

		SN54AC32		SN74AC32		UNIT
		MIN	MAX	MIN	MAX	
$V_{CC}$	Supply voltage	2	6	2	6	V
$V_{IH}$	High-level input voltage	$V_{CC} = 3 \text{ V}$	2.1	2.1		V
		$V_{CC} = 4.5 \text{ V}$	3.15	3.15		
		$V_{CC} = 5.5 \text{ V}$	3.85	3.85		
$V_{IL}$	Low-level input voltage	$V_{CC} = 3 \text{ V}$		0.9	0.9	V
		$V_{CC} = 4.5 \text{ V}$		1.35	1.35	
		$V_{CC} = 5.5 \text{ V}$		1.65	1.65	
$V_I$	Input voltage	0	$V_{CC}$	0	$V_{CC}$	V
$V_O$	Output voltage	0	$V_{CC}$	0	$V_{CC}$	V
$I_{OH}$	High-level output current	$V_{CC} = 3 \text{ V}$		-12	-12	mA
		$V_{CC} = 4.5 \text{ V}$		-24	-24	
		$V_{CC} = 5.5 \text{ V}$		-24	-24	
$I_{OL}$	Low-level output current	$V_{CC} = 3 \text{ V}$		12	12	mA
		$V_{CC} = 4.5 \text{ V}$		24	24	
		$V_{CC} = 5.5 \text{ V}$		24	24	
$\Delta t/\Delta v$	Input transition rise or fall rate		8		8	ns/V
$T_A$	Operating free-air temperature	-55	125	-40	85	°C

- (1) All unused inputs of the device must be held at  $V_{CC}$  or GND to ensure proper device operation. Refer to the TI application report, *Implications of Slow or Floating CMOS Inputs*, literature number SCBA004.

### 4.3 Thermal Information

THERMAL METRIC <sup>(1)</sup>		SNx4AC32					UNIT
		D	DB	N	NS	PW	
		14	14	14	14	14	
R <sub>θJA</sub>	Junction-to-ambient thermal resistance	119.9	96	80	76	145.7	°C/W

(1) For more information about traditional and new thermal metrics, see the [Semiconductor and IC package thermal metrics](#) application report.

### 4.4 Electrical Characteristics

over recommended operating free-air temperature range (unless otherwise noted)

PARAMETER	TEST CONDITIONS	V <sub>CC</sub>	T <sub>A</sub> = 25°C			SN54AC32		SN74AC32		UNIT
			MIN	TYP	MAX	MIN	MAX	MIN	MAX	
V <sub>OH</sub>	I <sub>OH</sub> = -50 μA	3 V	2.9			2.9	2.9		V	
		4.5 V	4.4			4.4	4.4			
		5.5 V	5.4			5.4	5.4			
	I <sub>OH</sub> = -12 mA	3 V	2.56			2.4	2.46			
		4.5 V	3.86			3.7	3.76			
	I <sub>OH</sub> = -24 mA	5.5 V	4.86			4.7	4.76			
		I <sub>OH</sub> = -50 mA <sup>(1)</sup>	5.5 V				3.85			
I <sub>OH</sub> = -75 mA <sup>(1)</sup>	5.5 V				3.85					
V <sub>OL</sub>	I <sub>OL</sub> = 50 μA	3 V	0.002 0.1		0.1		0.1		V	
		4.5 V	0.001 0.1		0.1		0.1			
		5.5 V	0.001 0.1		0.1		0.1			
	I <sub>OL</sub> = 12 mA	3 V	0.36		0.5		0.44			
		4.5 V	0.36		0.5		0.44			
	I <sub>OL</sub> = 24 mA	5.5 V	0.36		0.5		0.44			
		I <sub>OL</sub> = 50 mA <sup>(1)</sup>	5.5 V			1.65				
I <sub>OL</sub> = 75 mA <sup>(1)</sup>	5.5 V					1.65				
I <sub>I</sub>	A or B ports	V <sub>I</sub> = V <sub>CC</sub> or GND	5.5 V	±0.1		±1		±1		μA
I <sub>CC</sub>		V <sub>I</sub> = V <sub>CC</sub> or GND, I <sub>O</sub> = 0	5.5 V	2		40		20		μA
C <sub>i</sub>		V <sub>I</sub> = V <sub>CC</sub> or GND	5 V	2.6						pF

(1) Not more than one output should be tested at a time, and the duration of the test should not exceed 2 ms.

### 4.5 Switching Characteristics, V<sub>CC</sub> = 3.3 V ± 0.3 V

over recommended operating free-air temperature range, V<sub>CC</sub> = 3.3 V ± 0.3 V (unless otherwise noted) (see [Load Circuit and Voltage Waveforms](#))

PARAMETER	FROM (INPUT)	TO (OUTPUT)	T <sub>A</sub> = 25°C			SN54AC32		SN74AC32		UNIT
			MIN	TYP	MAX	MIN	MAX	MIN	MAX	
t <sub>PLH</sub>	A or B	Y	1.5	7	9	1	12	1.5	10	ns
t <sub>PHL</sub>			1.5	7	8.5	1	11.5	1	9	

#### 4.6 Switching Characteristics, $V_{CC} = 5\text{ V} \pm 0.5\text{ V}$

over recommended operating free-air temperature range,  $V_{CC} = 5\text{ V} \pm 0.5\text{ V}$  (unless otherwise noted) (see [Load Circuit and Voltage Waveforms](#))

PARAMETER	FROM (INPUT)	TO (OUTPUT)	$T_A = 25^\circ\text{C}$			SN54AC32		SN74AC32		UNIT
			MIN	TYP	MAX	MIN	MAX	MIN	MAX	
$t_{PLH}$	A or B	Y	1.5	5.5	7.5	1	9	1	8.5	ns
$t_{PHL}$			1.5	5	7	1	8.5	1	7.5	

#### 4.7 Operating Characteristics

$V_{CC} = 5\text{ V}$ ,  $T_A = 25^\circ\text{C}$

PARAMETER		TEST CONDITIONS		TYP	UNIT
$C_{pd}$	Power dissipation capacitance	$C_L = 50\text{ pF}$ ,	$f = 1\text{ MHz}$	40	pF

## 5 Parameter Measurement Information

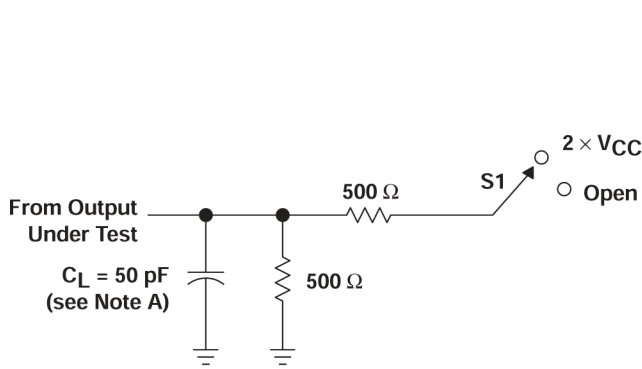

**LOAD CIRCUIT**

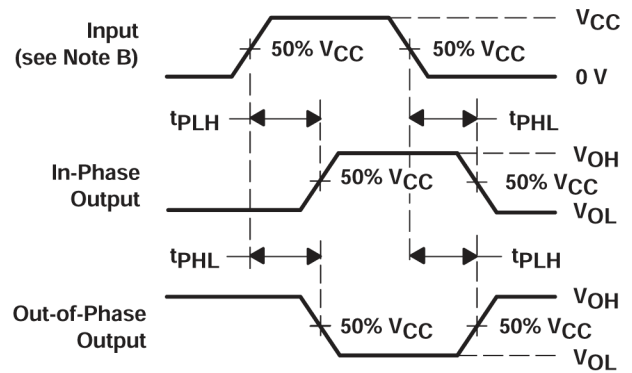

**VOLTAGE WAVEFORMS**

- A.  $C_L$  includes probe and jig capacitance.
- B. All input pulses are supplied by generators having the following characteristics:  $PRR \leq 1 \text{ MHz}$ ,  $Z_O = 50 \Omega$ ,  $t_r \leq 2.5 \text{ ns}$ ,  $t_f \leq 2.5 \text{ ns}$ .
- C. The outputs are measured one at a time with one input transition per measurement.

**5-1. Load Circuit and Voltage Waveforms**

TEST	S1
$t_{PLH}/t_{PHL}$	Open

## 6 Detailed Description

### 6.1 Functional Block Diagram



図 6-1. Logic Diagram, Each Gate (Positive Logic)

### 6.2 Device Functional Modes

表 6-1. Function Table (Each Gate)

INPUTS		OUTPUT Y
A	B	
H	X	H
X	H	H
L	L	L



## 7 Application and Implementation

### 注

以下のアプリケーション情報は、TI の製品仕様に含まれるものではなく、TI ではその正確性または完全性を保証いたしません。個々の目的に対する製品の適合性については、お客様の責任で判断していただくことになります。お客様は自身の設計実装を検証しテストすることで、システムの機能を確認する必要があります。

### 7.1 Power Supply Recommendations

The power supply can be any voltage between the minimum and maximum supply voltage rating located in the *Recommended Operating Conditions*. Each  $V_{CC}$  terminal should have a good bypass capacitor to prevent power disturbance. A 0.1- $\mu\text{F}$  capacitor is recommended for this device. It is acceptable to parallel multiple bypass capacitors to reject different frequencies of noise. The 0.1- $\mu\text{F}$  and 1- $\mu\text{F}$  capacitors are commonly used in parallel. The bypass capacitor should be installed as close to the power terminal as possible for best results, as shown in *Layout Example*.

### 7.2 Layout

#### 7.2.1 Layout Guidelines

When using multiple bit logic devices inputs should not ever float.

In many cases, functions or parts of functions of digital logic devices are unused, for example, when only two inputs of a triple-input AND gate are used or only three of the four buffer gates are used. Such input pins should not be left unconnected because the undefined voltages at the outside connections result in undefined operational states. Specified below are the rules that must be observed under all circumstances. All unused inputs of digital logic devices must be connected to a high or low bias to prevent them from floating. The logic level that should be applied to any particular unused input depends on the function of the device. Generally they will be tied to GND or  $V_{CC}$  whichever make more sense or is more convenient. Floating outputs is generally acceptable, unless the part is a transceiver. If the transceiver has an output enable pin it will disable the outputs section of the part when asserted. This will not disable the input section of the I.O's so they also cannot float when disabled.

#### 7.2.2 Layout Example



図 7-1. Layout Example for the SNx4AC32

## 8 Device and Documentation Support

TI offers an extensive line of development tools. Tools and software to evaluate the performance of the device, generate code, and develop solutions are listed below.

### 8.1 Documentation Support (Analog)

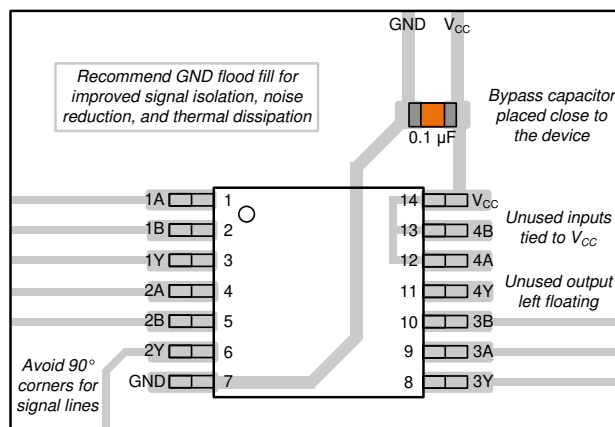
#### 8.1.1 Related Documentation

The table below lists quick access links. Categories include technical documents, support and community resources, tools and software, and quick access to sample or buy.

表 8-1. Related Links

PARTS	PRODUCT FOLDER	SAMPLE & BUY	TECHNICAL DOCUMENTS	TOOLS & SOFTWARE	SUPPORT & COMMUNITY
SN54AC32	<a href="#">Click here</a>	<a href="#">Click here</a>	<a href="#">Click here</a>	<a href="#">Click here</a>	<a href="#">Click here</a>
SN74AC32	<a href="#">Click here</a>	<a href="#">Click here</a>	<a href="#">Click here</a>	<a href="#">Click here</a>	<a href="#">Click here</a>

### 8.2 ドキュメントの更新通知を受け取る方法

ドキュメントの更新についての通知を受け取るには、[www.tij.co.jp](http://www.tij.co.jp) のデバイス製品フォルダを開いてください。[通知] をクリックして登録すると、変更されたすべての製品情報に関するダイジェストを毎週受け取ることができます。変更の詳細については、改訂されたドキュメントに含まれている改訂履歴をご覧ください。

### 8.3 サポート・リソース

[テキサス・インスツルメンツ E2E™ サポート・フォーラム](#) は、エンジニアが検証済みの回答と設計に関するヒントをエキスパートから迅速かつ直接得ることができる場所です。既存の回答を検索したり、独自の質問をしたりすることで、設計に必要な支援を迅速に得ることができます。

リンクされているコンテンツは、各寄稿者により「現状のまま」提供されるものです。これらはテキサス・インスツルメンツの仕様を構成するものではなく、必ずしもテキサス・インスツルメンツの見解を反映したものではありません。テキサス・インスツルメンツの[使用条件](#)を参照してください。

### 8.4 Trademarks

テキサス・インスツルメンツ E2E™ is a trademark of Texas Instruments.

すべての商標は、それぞれの所有者に帰属します。

### 8.5 静電気放電に関する注意事項



この IC は、ESD によって破損する可能性があります。テキサス・インスツルメンツは、IC を取り扱う際には常に適切な注意を払うことを推奨します。正しい取り扱いおよび設置手順に従わない場合、デバイスを破損するおそれがあります。

ESD による破損は、わずかな性能低下からデバイスの完全な故障まで多岐にわたります。精密な IC の場合、パラメータがわずかに変化するだけで公表されている仕様から外れる可能性があるため、破損が発生しやすくなっています。

### 8.6 用語集

[テキサス・インスツルメンツ用語集](#) この用語集には、用語や略語の一覧および定義が記載されています。

## 9 Revision History

資料番号末尾の英字は改訂を表しています。その改訂履歴は英語版に準じています。

Changes from Revision E (July 2024) to Revision F (December 2024)	Page
• Corrected $V_{IH}$ values in <i>Recommended Operating Conditions</i> table.....	4

<b>Changes from Revision D (October 2023) to Revision E (July 2024)</b>	<b>Page</b>
<ul style="list-style-type: none"> <li>• 製品情報の表、ピンの機能の表、熱に関する情報の表、「デバイスの機能モード」、「アプリケーションと実装」セクション、「デバイスおよびドキュメントのサポート」セクション、および「メカニカル、パッケージ、および注文情報」セクションを追加 .....</li> <li>• Updated RθJA values: D = 86 to 119.9, PW = 113 to 145.7, all values in °C/W.....</li> </ul>	<p>1</p> <p>5</p>

## 10 Mechanical, Packaging, and Orderable Information

The following pages include mechanical, packaging, and orderable information. This information is the most current data available for the designated devices. This data is subject to change without notice and revision of this document. For browser-based versions of this data sheet, refer to the left-hand navigation.

**PACKAGING INFORMATION**

Orderable Device	Status (1)	Package Type	Package Drawing	Pins	Package Qty	Eco Plan (2)	Lead finish/ Ball material (6)	MSL Peak Temp (3)	Op Temp (°C)	Device Marking (4/5)	Samples
5962-87614012A	ACTIVE	LCCC	FK	20	55	Non-RoHS & Green	SNPB	N / A for Pkg Type	-55 to 125	5962- 87614012A SNJ54AC 32FK	<a href="#">Samples</a>
5962-8761401CA	ACTIVE	CDIP	J	14	25	Non-RoHS & Green	SNPB	N / A for Pkg Type	-55 to 125	5962-8761401CA SNJ54AC32J	<a href="#">Samples</a>
5962-8761401DA	ACTIVE	CFP	W	14	25	Non-RoHS & Green	SNPB	N / A for Pkg Type	-55 to 125	5962-8761401DA SNJ54AC32W	<a href="#">Samples</a>
SN74AC32D	OBSOLETE	SOIC	D	14		TBD	Call TI	Call TI	-40 to 85	AC32	
SN74AC32DBR	ACTIVE	SSOP	DB	14	2000	RoHS & Green	NIPDAU	Level-1-260C-UNLIM	-40 to 85	AC32	<a href="#">Samples</a>
SN74AC32DR	ACTIVE	SOIC	D	14	2500	RoHS & Green	NIPDAU	Level-1-260C-UNLIM	-40 to 85	AC32	<a href="#">Samples</a>
SN74AC32N	ACTIVE	PDIP	N	14	25	RoHS & Green	NIPDAU	N / A for Pkg Type	-40 to 85	SN74AC32N	<a href="#">Samples</a>
SN74AC32NSR	ACTIVE	SOP	NS	14	2000	RoHS & Green	NIPDAU	Level-1-260C-UNLIM	-40 to 85	AC32	<a href="#">Samples</a>
SN74AC32PW	OBSOLETE	TSSOP	PW	14		TBD	Call TI	Call TI	-40 to 85	AC32	
SN74AC32PWR	ACTIVE	TSSOP	PW	14	2000	RoHS & Green	NIPDAU	Level-1-260C-UNLIM	-40 to 85	AC32	<a href="#">Samples</a>
SN74AC32PWRG4	ACTIVE	TSSOP	PW	14	2000	RoHS & Green	NIPDAU	Level-1-260C-UNLIM	-40 to 85	AC32	<a href="#">Samples</a>
SNJ54AC32FK	ACTIVE	LCCC	FK	20	55	Non-RoHS & Green	SNPB	N / A for Pkg Type	-55 to 125	5962- 87614012A SNJ54AC 32FK	<a href="#">Samples</a>
SNJ54AC32J	ACTIVE	CDIP	J	14	25	Non-RoHS & Green	SNPB	N / A for Pkg Type	-55 to 125	5962-8761401CA SNJ54AC32J	<a href="#">Samples</a>
SNJ54AC32W	ACTIVE	CFP	W	14	25	Non-RoHS & Green	SNPB	N / A for Pkg Type	-55 to 125	5962-8761401DA SNJ54AC32W	<a href="#">Samples</a>

(1) The marketing status values are defined as follows:

**ACTIVE:** Product device recommended for new designs.

**LIFEBUY:** TI has announced that the device will be discontinued, and a lifetime-buy period is in effect.

**NRND:** Not recommended for new designs. Device is in production to support existing customers, but TI does not recommend using this part in a new design.

**PREVIEW:** Device has been announced but is not in production. Samples may or may not be available.

**OBSOLETE:** TI has discontinued the production of the device.

<sup>(2)</sup> **RoHS:** TI defines "RoHS" to mean semiconductor products that are compliant with the current EU RoHS requirements for all 10 RoHS substances, including the requirement that RoHS substance do not exceed 0.1% by weight in homogeneous materials. Where designed to be soldered at high temperatures, "RoHS" products are suitable for use in specified lead-free processes. TI may reference these types of products as "Pb-Free".

**RoHS Exempt:** TI defines "RoHS Exempt" to mean products that contain lead but are compliant with EU RoHS pursuant to a specific EU RoHS exemption.

**Green:** TI defines "Green" to mean the content of Chlorine (Cl) and Bromine (Br) based flame retardants meet JS709B low halogen requirements of  $\leq 1000$ ppm threshold. Antimony trioxide based flame retardants must also meet the  $\leq 1000$ ppm threshold requirement.

<sup>(3)</sup> MSL, Peak Temp. - The Moisture Sensitivity Level rating according to the JEDEC industry standard classifications, and peak solder temperature.

<sup>(4)</sup> There may be additional marking, which relates to the logo, the lot trace code information, or the environmental category on the device.

<sup>(5)</sup> Multiple Device Markings will be inside parentheses. Only one Device Marking contained in parentheses and separated by a "~" will appear on a device. If a line is indented then it is a continuation of the previous line and the two combined represent the entire Device Marking for that device.

<sup>(6)</sup> Lead finish/Ball material - Orderable Devices may have multiple material finish options. Finish options are separated by a vertical ruled line. Lead finish/Ball material values may wrap to two lines if the finish value exceeds the maximum column width.

**Important Information and Disclaimer:**The information provided on this page represents TI's knowledge and belief as of the date that it is provided. TI bases its knowledge and belief on information provided by third parties, and makes no representation or warranty as to the accuracy of such information. Efforts are underway to better integrate information from third parties. TI has taken and continues to take reasonable steps to provide representative and accurate information but may not have conducted destructive testing or chemical analysis on incoming materials and chemicals. TI and TI suppliers consider certain information to be proprietary, and thus CAS numbers and other limited information may not be available for release.

In no event shall TI's liability arising out of such information exceed the total purchase price of the TI part(s) at issue in this document sold by TI to Customer on an annual basis.

**OTHER QUALIFIED VERSIONS OF SN54AC32, SN74AC32 :**

- Catalog : [SN74AC32](#)
  
- Enhanced Product : [SN74AC32-EP](#), [SN74AC32-EP](#)
  
- Military : [SN54AC32](#)

NOTE: Qualified Version Definitions:

- Catalog - TI's standard catalog product
  
- Enhanced Product - Supports Defense, Aerospace and Medical Applications

- Military - QML certified for Military and Defense Applications

**TAPE AND REEL INFORMATION**

**QUADRANT ASSIGNMENTS FOR PIN 1 ORIENTATION IN TAPE**

\*All dimensions are nominal

Device	Package Type	Package Drawing	Pins	SPQ	Reel Diameter (mm)	Reel Width W1 (mm)	A0 (mm)	B0 (mm)	K0 (mm)	P1 (mm)	W (mm)	Pin1 Quadrant
SN74AC32DBR	SSOP	DB	14	2000	330.0	16.4	8.35	6.6	2.4	12.0	16.0	Q1
SN74AC32DR	SOIC	D	14	2500	330.0	16.4	6.5	9.0	2.1	8.0	16.0	Q1
SN74AC32DR	SOIC	D	14	2500	330.0	16.4	6.5	9.0	2.1	8.0	16.0	Q1
SN74AC32DR	SOIC	D	14	2500	330.0	16.4	6.5	9.0	2.1	8.0	16.0	Q1
SN74AC32NSR	SOP	NS	14	2000	330.0	16.4	8.2	10.5	2.5	12.0	16.0	Q1
SN74AC32PWR	TSSOP	PW	14	2000	330.0	12.4	6.9	5.6	1.6	8.0	12.0	Q1
SN74AC32PWR	TSSOP	PW	14	2000	330.0	12.4	6.9	5.6	1.6	8.0	12.0	Q1
SN74AC32PWRG4	TSSOP	PW	14	2000	330.0	12.4	6.9	5.6	1.6	8.0	12.0	Q1
SN74AC32PWRG4	TSSOP	PW	14	2000	330.0	12.4	6.9	5.6	1.6	8.0	12.0	Q1

**TAPE AND REEL BOX DIMENSIONS**

\*All dimensions are nominal

Device	Package Type	Package Drawing	Pins	SPQ	Length (mm)	Width (mm)	Height (mm)
SN74AC32DBR	SSOP	DB	14	2000	356.0	356.0	35.0
SN74AC32DR	SOIC	D	14	2500	356.0	356.0	35.0
SN74AC32DR	SOIC	D	14	2500	353.0	353.0	32.0
SN74AC32DR	SOIC	D	14	2500	353.0	353.0	32.0
SN74AC32NSR	SOP	NS	14	2000	367.0	367.0	38.0
SN74AC32PWR	TSSOP	PW	14	2000	353.0	353.0	32.0
SN74AC32PWR	TSSOP	PW	14	2000	356.0	356.0	35.0
SN74AC32PWRG4	TSSOP	PW	14	2000	353.0	353.0	32.0
SN74AC32PWRG4	TSSOP	PW	14	2000	356.0	356.0	35.0



**TUBE**

\*All dimensions are nominal

Device	Package Name	Package Type	Pins	SPQ	L (mm)	W (mm)	T (μm)	B (mm)
5962-87614012A	FK	LCCC	20	55	506.98	12.06	2030	NA
5962-8761401DA	W	CFP	14	25	506.98	26.16	6220	NA
SN74AC32N	N	PDIP	14	25	506	13.97	11230	4.32
SN74AC32N	N	PDIP	14	25	506	13.97	11230	4.32
SNJ54AC32FK	FK	LCCC	20	55	506.98	12.06	2030	NA
SNJ54AC32W	W	CFP	14	25	506.98	26.16	6220	NA

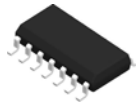

# D0014A

# PACKAGE OUTLINE

## SOIC - 1.75 mm max height

SMALL OUTLINE INTEGRATED CIRCUIT

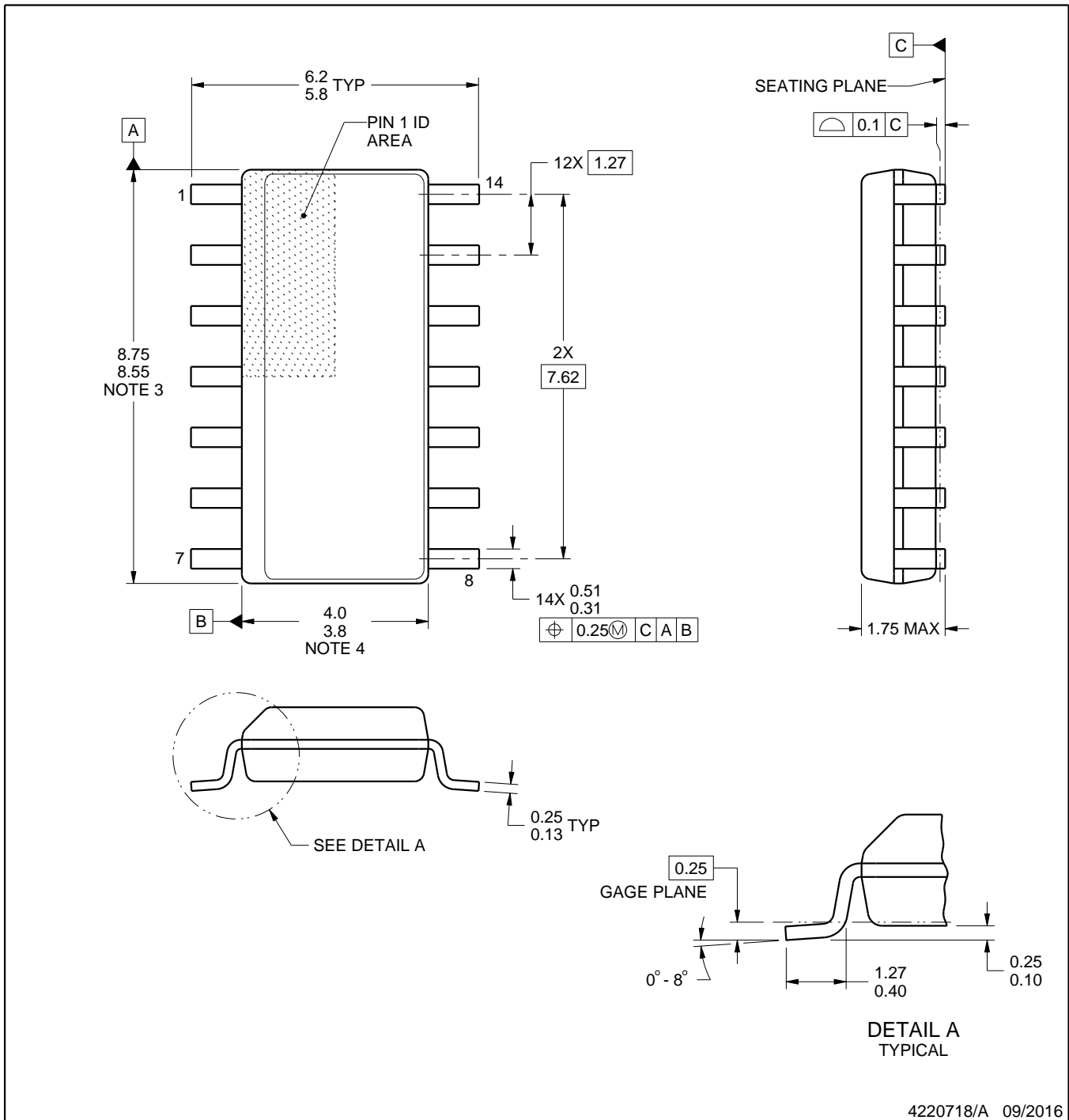

4220718/A 09/2016

### NOTES:

1. All linear dimensions are in millimeters. Dimensions in parenthesis are for reference only. Dimensioning and tolerancing per ASME Y14.5M.
2. This drawing is subject to change without notice.
3. This dimension does not include mold flash, protrusions, or gate burrs. Mold flash, protrusions, or gate burrs shall not exceed 0.15 mm, per side.
4. This dimension does not include interlead flash. Interlead flash shall not exceed 0.43 mm, per side.
5. Reference JEDEC registration MS-012, variation AB.

# EXAMPLE BOARD LAYOUT

D0014A

SOIC - 1.75 mm max height

SMALL OUTLINE INTEGRATED CIRCUIT



LAND PATTERN EXAMPLE  
SCALE:8X



SOLDER MASK DETAILS

4220718/A 09/2016

NOTES: (continued)

- 6. Publication IPC-7351 may have alternate designs.
- 7. Solder mask tolerances between and around signal pads can vary based on board fabrication site.

# EXAMPLE STENCIL DESIGN

D0014A

SOIC - 1.75 mm max height

SMALL OUTLINE INTEGRATED CIRCUIT



SOLDER PASTE EXAMPLE  
BASED ON 0.125 mm THICK STENCIL  
SCALE:8X

4220718/A 09/2016

NOTES: (continued)

8. Laser cutting apertures with trapezoidal walls and rounded corners may offer better paste release. IPC-7525 may have alternate design recommendations.
9. Board assembly site may have different recommendations for stencil design.

# MECHANICAL DATA

NS (R-PDSO-G\*\*)

PLASTIC SMALL-OUTLINE PACKAGE

14-PINS SHOWN



- NOTES:
- A. All linear dimensions are in millimeters.
  - B. This drawing is subject to change without notice.
  - C. Body dimensions do not include mold flash or protrusion, not to exceed 0,15.

W (R-GDFP-F14)

CERAMIC DUAL FLATPACK



4040180-2/F 04/14

- NOTES:
- A. All linear dimensions are in inches (millimeters).
  - B. This drawing is subject to change without notice.
  - C. This package can be hermetically sealed with a ceramic lid using glass frit.
  - D. Index point is provided on cap for terminal identification only.
  - E. Falls within MIL STD 1835 GDFP1-F14

# DB0014A



# PACKAGE OUTLINE

## SSOP - 2 mm max height

SMALL OUTLINE PACKAGE

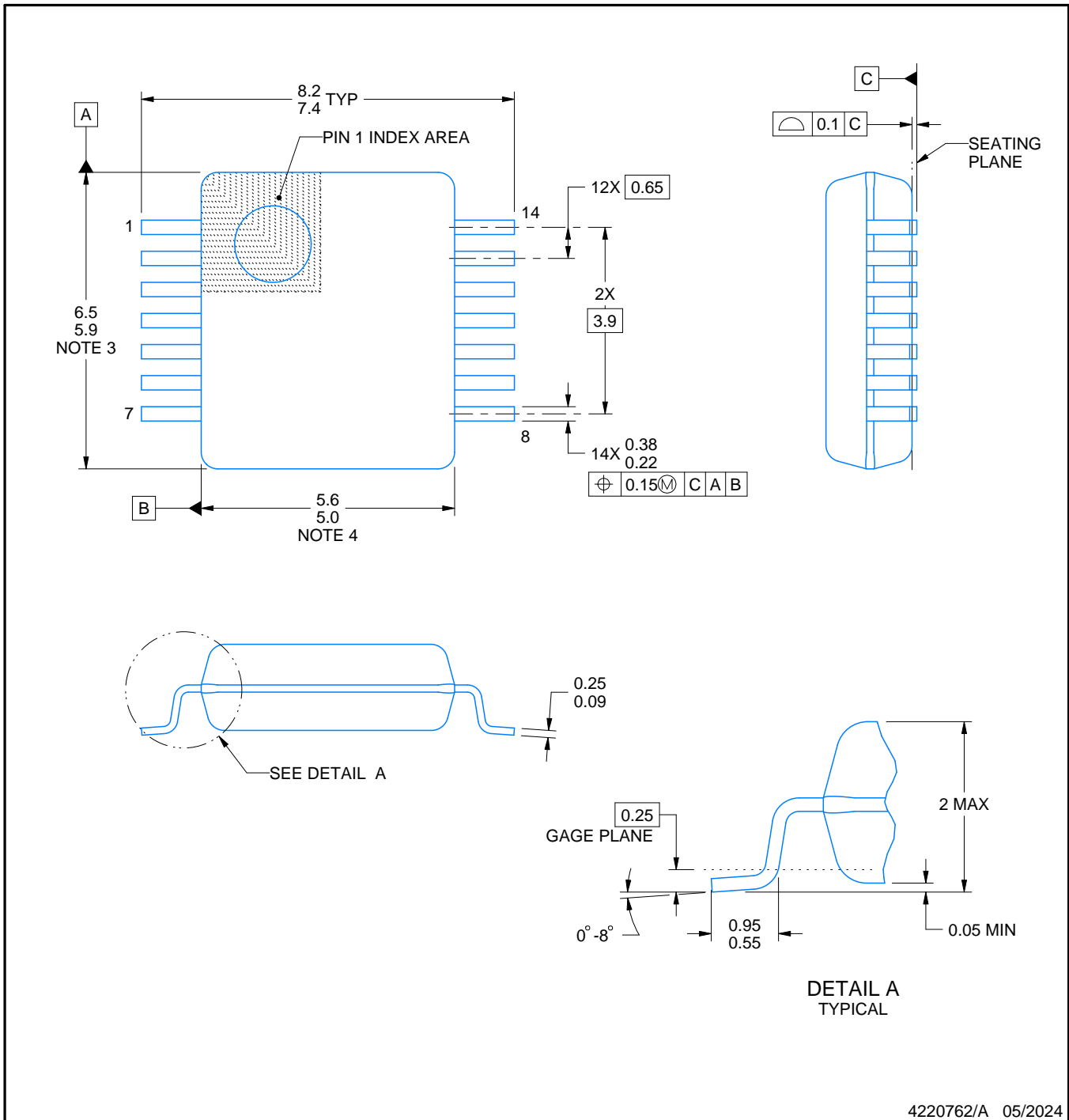

### NOTES:

1. All linear dimensions are in millimeters. Any dimensions in parenthesis are for reference only. Dimensioning and tolerancing per ASME Y14.5M.
2. This drawing is subject to change without notice.
3. This dimension does not include mold flash, protrusions, or gate burrs. Mold flash, protrusions, or gate burrs shall not exceed 0.15 mm per side.
4. Reference JEDEC registration MO-150.

# EXAMPLE BOARD LAYOUT

DB0014A

SSOP - 2 mm max height

SMALL OUTLINE PACKAGE

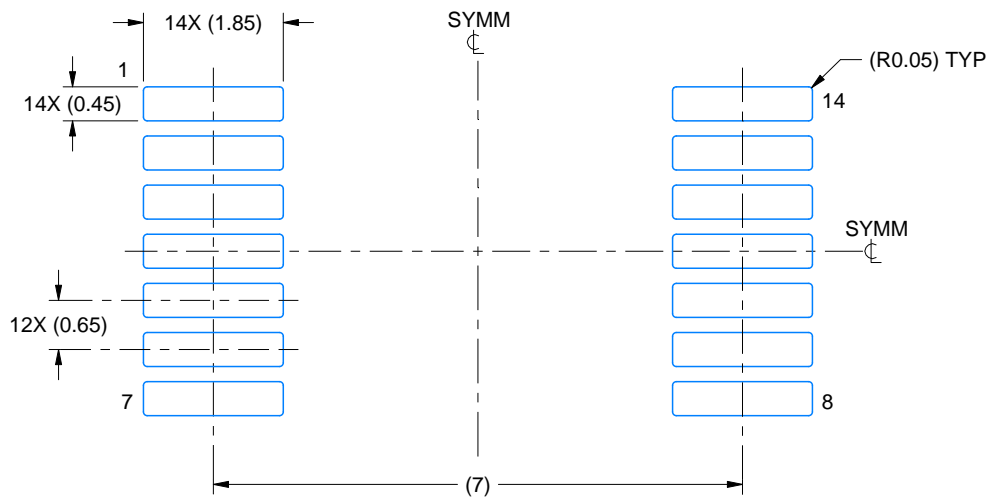

LAND PATTERN EXAMPLE  
EXPOSED METAL SHOWN  
SCALE: 10X

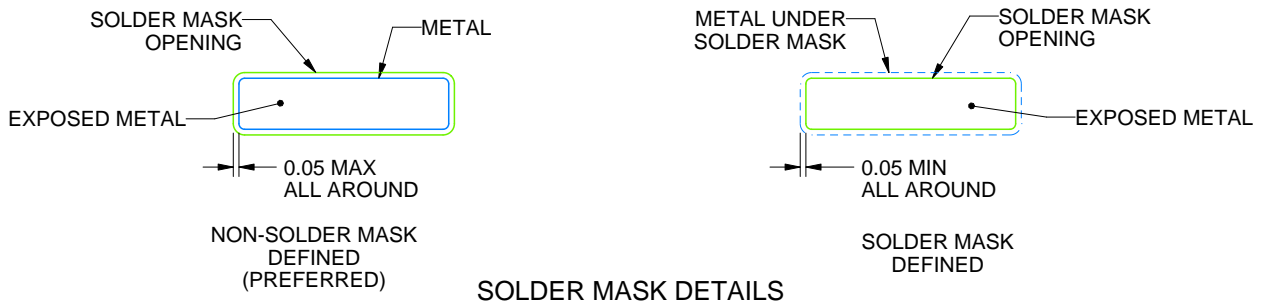

4220762/A 05/2024

NOTES: (continued)

5. Publication IPC-7351 may have alternate designs.
6. Solder mask tolerances between and around signal pads can vary based on board fabrication site.



# EXAMPLE STENCIL DESIGN

DB0014A

SSOP - 2 mm max height

SMALL OUTLINE PACKAGE

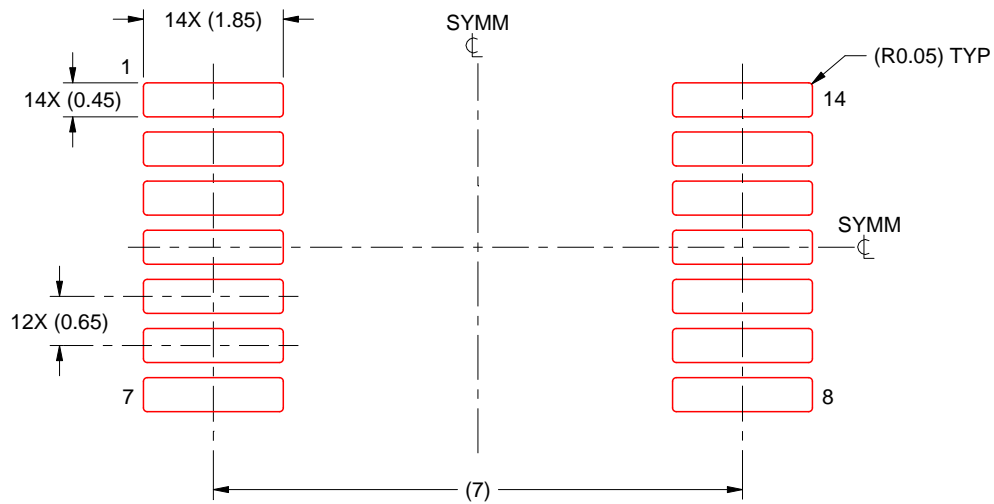

SOLDER PASTE EXAMPLE  
BASED ON 0.125 mm THICK STENCIL  
SCALE: 10X

4220762/A 05/2024

NOTES: (continued)

7. Laser cutting apertures with trapezoidal walls and rounded corners may offer better paste release. IPC-7525 may have alternate design recommendations.
8. Board assembly site may have different recommendations for stencil design.

## GENERIC PACKAGE VIEW

**FK 20**

**LCCC - 2.03 mm max height**

8.89 x 8.89, 1.27 mm pitch

LEADLESS CERAMIC CHIP CARRIER

This image is a representation of the package family, actual package may vary.  
Refer to the product data sheet for package details.

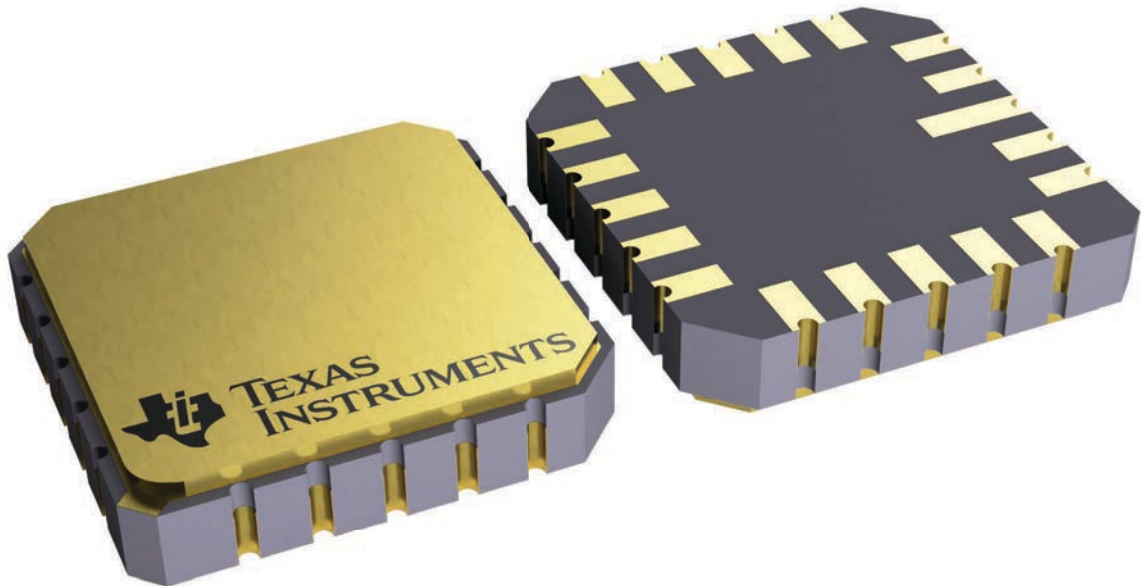

4229370VA\

J 14

**GENERIC PACKAGE VIEW**  
**CDIP - 5.08 mm max height**  
CERAMIC DUAL IN LINE PACKAGE

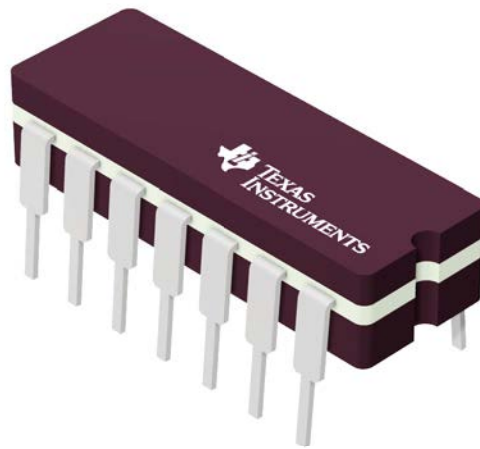

Images above are just a representation of the package family, actual package may vary.  
Refer to the product data sheet for package details.

4040083-5/G

J0014A



# PACKAGE OUTLINE

CDIP - 5.08 mm max height

CERAMIC DUAL IN LINE PACKAGE



4214771/A 05/2017

NOTES:

1. All controlling linear dimensions are in inches. Dimensions in brackets are in millimeters. Any dimension in brackets or parenthesis are for reference only. Dimensioning and tolerancing per ASME Y14.5M.
2. This drawing is subject to change without notice.
3. This package is hermetically sealed with a ceramic lid using glass frit.
4. Index point is provided on cap for terminal identification only and on press ceramic glass frit seal only.
5. Falls within MIL-STD-1835 and GDIP1-T14.

# EXAMPLE BOARD LAYOUT

J0014A

CDIP - 5.08 mm max height

CERAMIC DUAL IN LINE PACKAGE



LAND PATTERN EXAMPLE  
NON-SOLDER MASK DEFINED  
SCALE: 5X

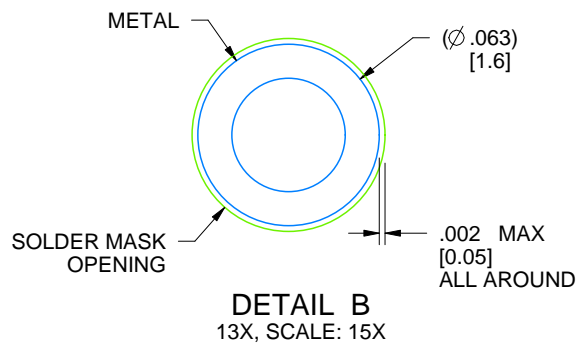

4214771/A 05/2017

N (R-PDIP-T\*\*)

PLASTIC DUAL-IN-LINE PACKAGE

16 PINS SHOWN



4040049/E 12/2002

- NOTES:
- A. All linear dimensions are in inches (millimeters).
  - B. This drawing is subject to change without notice.
  - $\triangle C$  Falls within JEDEC MS-001, except 18 and 20 pin minimum body length (Dim A).
  - $\triangle D$  The 20 pin end lead shoulder width is a vendor option, either half or full width.

PW0014A



**PACKAGE OUTLINE**  
**TSSOP - 1.2 mm max height**

SMALL OUTLINE PACKAGE

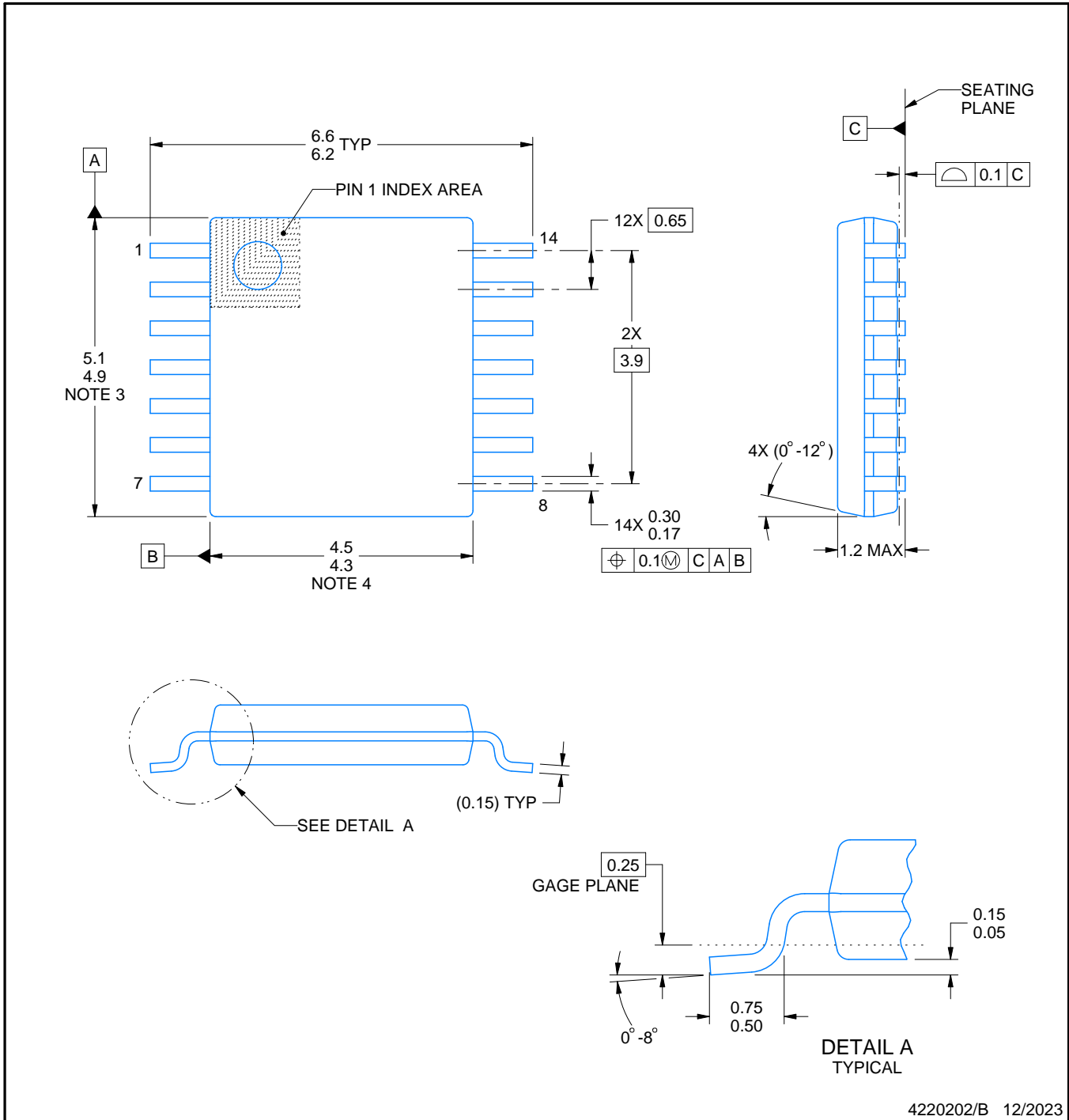

4220202/B 12/2023

NOTES:

1. All linear dimensions are in millimeters. Any dimensions in parenthesis are for reference only. Dimensioning and tolerancing per ASME Y14.5M.
2. This drawing is subject to change without notice.
3. This dimension does not include mold flash, protrusions, or gate burrs. Mold flash, protrusions, or gate burrs shall not exceed 0.15 mm per side.
4. This dimension does not include interlead flash. Interlead flash shall not exceed 0.25 mm per side.
5. Reference JEDEC registration MO-153.

# EXAMPLE BOARD LAYOUT

PW0014A

TSSOP - 1.2 mm max height

SMALL OUTLINE PACKAGE

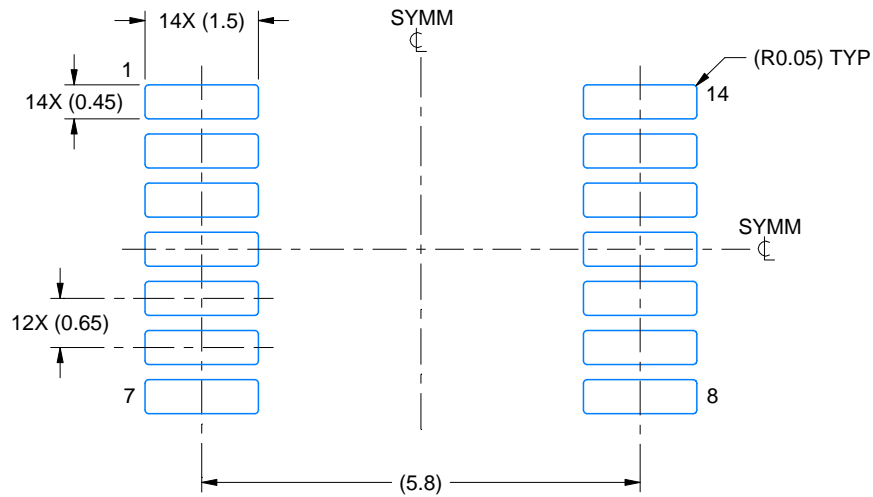

LAND PATTERN EXAMPLE  
EXPOSED METAL SHOWN  
SCALE: 10X



4220202/B 12/2023

NOTES: (continued)

- 6. Publication IPC-7351 may have alternate designs.
- 7. Solder mask tolerances between and around signal pads can vary based on board fabrication site.



# EXAMPLE STENCIL DESIGN

PW0014A

TSSOP - 1.2 mm max height

SMALL OUTLINE PACKAGE

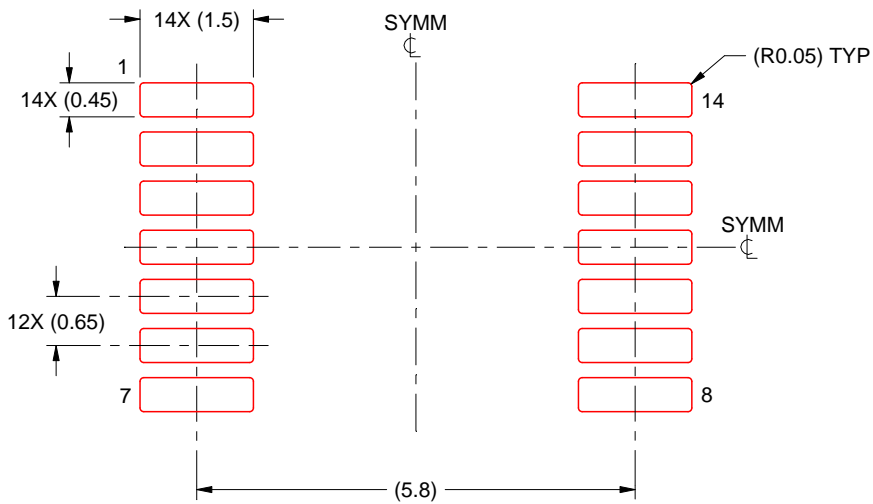

SOLDER PASTE EXAMPLE  
BASED ON 0.125 mm THICK STENCIL  
SCALE: 10X

4220202/B 12/2023

NOTES: (continued)

8. Laser cutting apertures with trapezoidal walls and rounded corners may offer better paste release. IPC-7525 may have alternate design recommendations.
9. Board assembly site may have different recommendations for stencil design.

## 重要なお知らせと免責事項

TI は、技術データと信頼性データ（データシートを含みます）、設計リソース（リファレンス・デザインを含みます）、アプリケーションや設計に関する各種アドバイス、Web ツール、安全性情報、その他のリソースを、欠陥が存在する可能性のある「現状のまま」提供しており、商品性および特定目的に対する適合性の黙示保証、第三者の知的財産権の非侵害保証を含むいかなる保証も、明示的または黙示的にかかわらず拒否します。

これらのリソースは、TI 製品を使用する設計の経験を積んだ開発者への提供を意図したものです。(1) お客様のアプリケーションに適した TI 製品の選定、(2) お客様のアプリケーションの設計、検証、試験、(3) お客様のアプリケーションに該当する各種規格や、その他のあらゆる安全性、セキュリティ、規制、または他の要件への確実な適合に関する責任を、お客様のみが単独で負うものとし、

上記の各種リソースは、予告なく変更される可能性があります。これらのリソースは、リソースで説明されている TI 製品を使用するアプリケーションの開発の目的でのみ、TI はその使用をお客様に許諾します。これらのリソースに関して、他の目的で複製することや掲載することは禁止されています。TI や第三者の知的財産権のライセンスが付与されている訳ではありません。お客様は、これらのリソースを自身で使用した結果発生するあらゆる申し立て、損害、費用、損失、責任について、TI およびその代理人を完全に補償するものとし、TI は一切の責任を拒否します。

TI の製品は、[TI の販売条件](#)、または [ti.com](#) やかかる TI 製品の関連資料などのいずれかを通じて提供する適用可能な条項の下で提供されています。TI がこれらのリソースを提供することは、適用される TI の保証または他の保証の放棄の拡大や変更を意味するものではありません。

お客様がいかなる追加条項または代替条項を提案した場合でも、TI はそれらに異議を唱え、拒否します。

郵送先住所：Texas Instruments, Post Office Box 655303, Dallas, Texas 75265  
Copyright © 2024, Texas Instruments Incorporated