

SN54147, SN54148, SN54LS147, SN54LS148 SN74147, SN74148 (TIM9907), SN74LS147, SN74LS148 10-LINE TO 4-LINE AND 8-LINE TO 3-LINE PRIORITY ENCODERS

SDLS053B – OCTOBER 1976 – REVISED MAY 2004

'147, 'LS147

- Encode 10-Line Decimal to 4-Line BCD
- Applications Include:
 - Keyboard Encoding
 - Range Selection

SN54147, SN54LS147 ... J OR W PACKAGE
SN74147, SN74LS147 ... D OR N PACKAGE
(TOP VIEW)

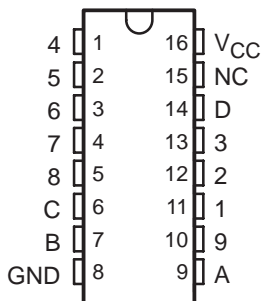

'148, 'LS148

- Encode 8 Data Lines to 3-Line Binary (Octal)
- Applications Include:
 - n-Bit Encoding
 - Code Converters and Generators

SN54148, SN54LS148 ... J OR W PACKAGE
SN74148, SN74LS148 ... D, N, OR NS PACKAGE
(TOP VIEW)

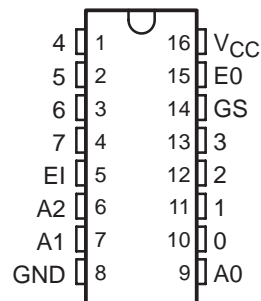

SN54LS147 ... FK PACKAGE
(TOP VIEW)

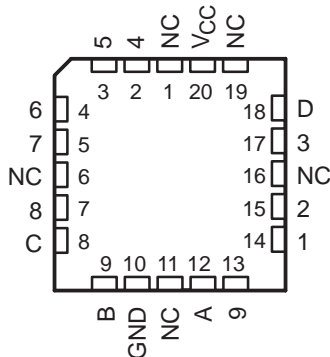

NC – No internal connection

SN54LS148 ... FK PACKAGE
(TOP VIEW)

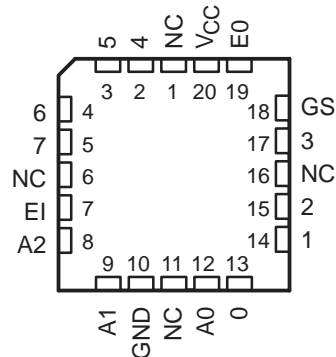

TYPE	TYPICAL DATA DELAY	TYPICAL POWER DISSIPATION
'147	10 ns	225 mW
'148	10 ns	190 mW
'LS147	15 ns	60 mW
'LS148	15 ns	60 mW

NOTE: The SN54147, SN54LS147, SN54148, SN74147, SN74LS147, and SN74148 are obsolete and are no longer supplied.



Please be aware that an important notice concerning availability, standard warranty, and use in critical applications of Texas Instruments semiconductor products and disclaimers thereto appears at the end of this data sheet.

PRODUCTION DATA information is current as of publication date. Products conform to specifications per the terms of Texas Instruments standard warranty. Production processing does not necessarily include testing of all parameters.

 **TEXAS
INSTRUMENTS**

POST OFFICE BOX 655303 • DALLAS, TEXAS 75265

Copyright © 2004, Texas Instruments Incorporated
On products compliant to MIL-PRF-38535, all parameters are tested unless otherwise noted. On all other products, production processing does not necessarily include testing of all parameters.

SN54147, SN54148, SN54LS147, SN54LS148
SN74147, SN74148 (TIM9907), SN74LS147, SN74LS148
10-LINE TO 4-LINE AND 8-LINE TO 3-LINE PRIORITY ENCODERS

SDLS053B – OCTOBER 1976 – REVISED MAY 2004

description/ordering information

These TTL encoders feature priority decoding of the inputs to ensure that only the highest-order data line is encoded. The '147 and 'LS147 devices encode nine data lines to four-line (8-4-2-1) BCD. The implied decimal zero condition requires no input condition, as zero is encoded when all nine data lines are at a high logic level. The '148 and 'LS148 devices encode eight data lines to three-line (4-2-1) binary (octal). Cascading circuitry (enable input EI and enable output EO) has been provided to allow octal expansion without the need for external circuitry. For all types, data inputs and outputs are active at the low logic level. All inputs are buffered to represent one normalized Series 54/74 or 54/74LS load, respectively.

ORDERING INFORMATION

T _A	PACKAGE†		ORDERABLE PART NUMBER	TOP-SIDE MARKING
0°C to 70°C	PDIP – N	Tube	SN74LS148N	SN74LS148N
	SOIC – D	Tube	SN74LS148D	LS148
		Tape and reel	SN74LS148DR	
	SOP – NS	Tape and reel	SN74LS148NSR	74LS148
–55°C to 125°C	CDIP – J	Tube	SNJ54LS148J	SNJ54LS148J
	CFP – W	Tube	SNJ54LS148W	SNJ54LS148W
	LCCC – FK	Tube	SNJ54LS148FK	SNJ54LS148FK

† Package drawings, standard packing quantities, thermal data, symbolization, and PCB design guidelines are available at www.ti.com/sc/package.

FUNCTION TABLE – '147, 'LS147

INPUTS									OUTPUTS			
1	2	3	4	5	6	7	8	9	D	C	B	A
H	H	H	H	H	H	H	H	H	H	H	H	H
X	X	X	X	X	X	X	X	L	L	H	H	L
X	X	X	X	X	X	X	L	H	L	H	H	H
X	X	X	X	X	X	L	H	H	H	L	L	L
X	X	X	X	L	H	H	H	H	H	L	H	L
X	X	X	L	H	H	H	H	H	H	L	H	H
X	X	L	H	H	H	H	H	H	H	H	L	L
X	L	H	H	H	H	H	H	H	H	H	L	H
L	H	H	H	H	H	H	H	H	H	H	H	L

H = high logic level, L = low logic level, X = irrelevant



SN54147, SN54148, SN54LS147, SN54LS148
SN74147, SN74148 (TIM9907), SN74LS147, SN74LS148
10-LINE TO 4-LINE AND 8-LINE TO 3-LINE PRIORITY ENCODERS

SDLS053B – OCTOBER 1976 – REVISED MAY 2004

FUNCTION TABLE – '148, 'LS148

INPUTS									OUTPUTS				
EI	0	1	2	3	4	5	6	7	A2	A1	A0	GS	EO
H	X	X	X	X	X	X	X	X	H	H	H	H	H
L	H	H	H	H	H	H	H	H	H	H	H	H	L
L	X	X	X	X	X	X	X	L	L	L	L	L	H
L	X	X	X	X	X	X	L	H	L	L	H	L	H
L	X	X	X	X	X	L	H	H	L	H	L	L	H
L	X	X	X	L	H	H	H	H	L	H	L	L	H
L	X	X	L	H	H	H	H	H	H	L	H	L	H
L	X	L	H	H	H	H	H	H	H	H	L	L	H
L	L	H	H	H	H	H	H	H	H	H	H	L	H

H = high logic level, L = low logic level, X = irrelevant

**SN54147, SN54148, SN54LS147, SN54LS148
 SN74147, SN74148 (TIM9907), SN74LS147, SN74LS148
 10-LINE TO 4-LINE AND 8-LINE TO 3-LINE PRIORITY ENCODERS**

SDLS053B - OCTOBER 1976 - REVISED MAY 2004

'147, 'LS147 logic diagram (positive logic)

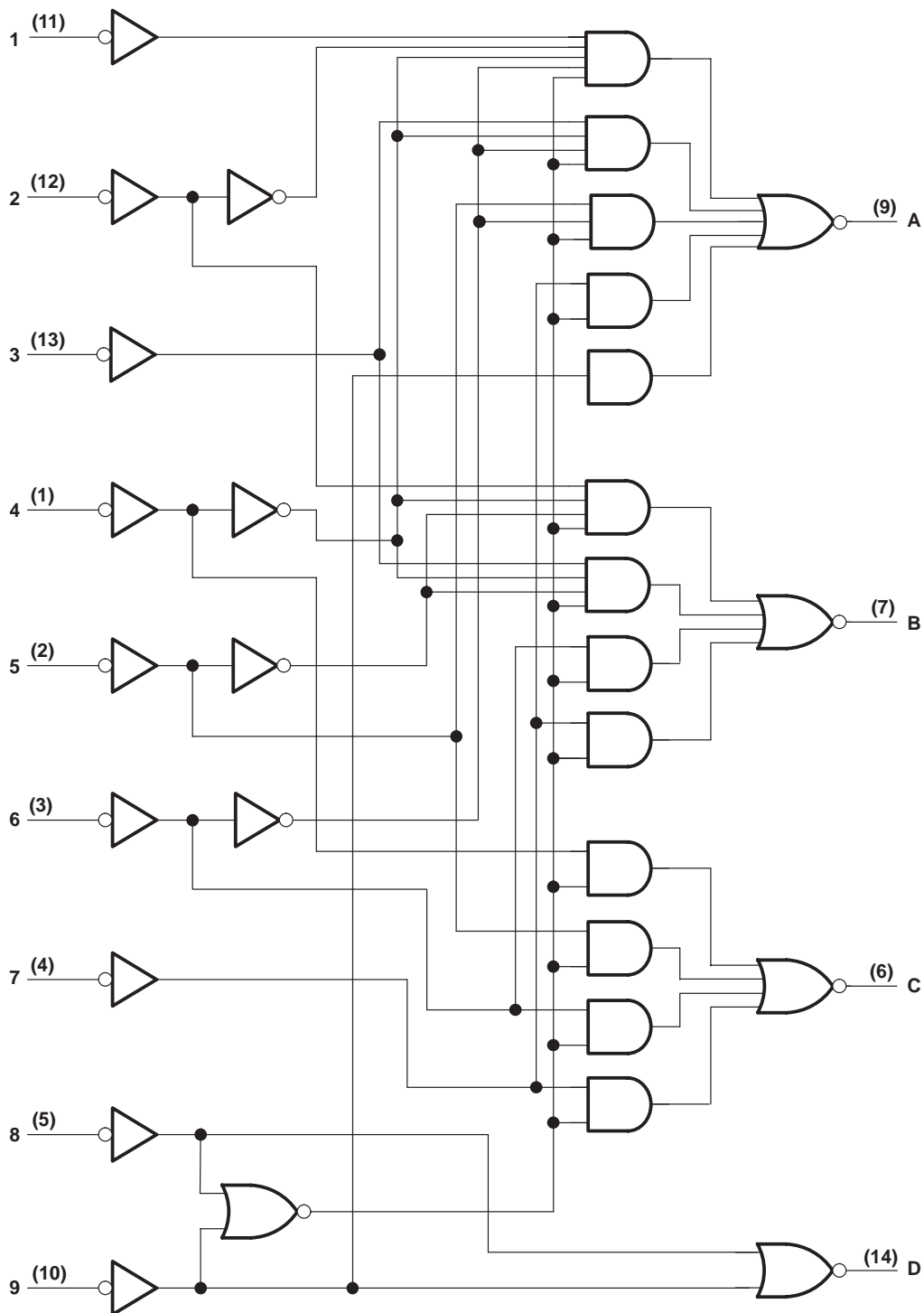

Pin numbers shown are for D, J, N, and W packages.



POST OFFICE BOX 655303 • DALLAS, TEXAS 75265

**SN54147, SN54148, SN54LS147, SN54LS148
SN74147, SN74148 (TIM9907), SN74LS147, SN74LS148
10-LINE TO 4-LINE AND 8-LINE TO 3-LINE PRIORITY ENCODERS**

SDLS053B - OCTOBER 1976 - REVISED MAY 2004

'148, 'LS148 logic diagram (positive logic)

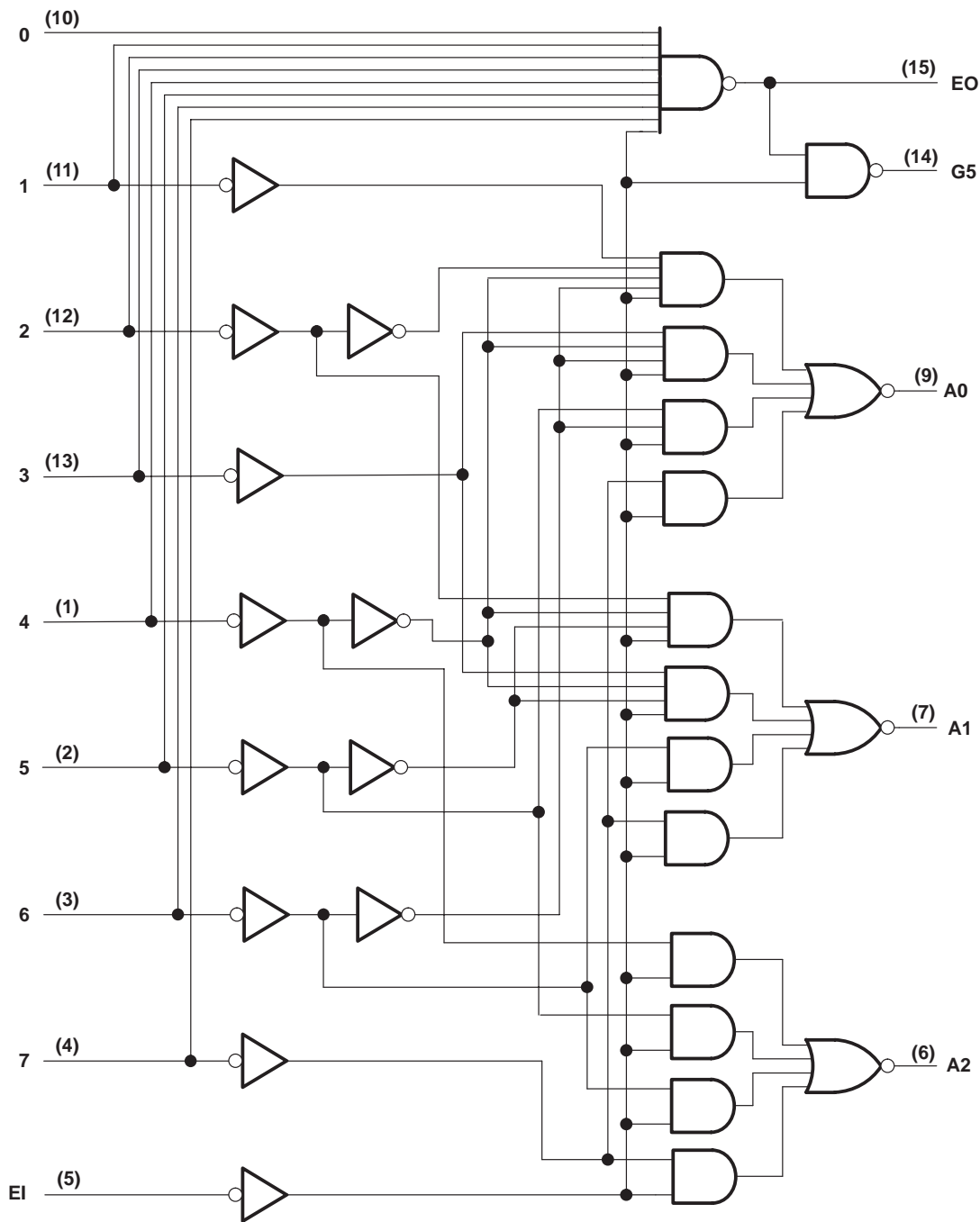

Pin numbers shown are for D, J, N, NS, and W packages.

**SN54147, SN54148, SN54LS147, SN54LS148
 SN74147, SN74148 (TIM9907), SN74LS147, SN74LS148
 10-LINE TO 4-LINE AND 8-LINE TO 3-LINE PRIORITY ENCODERS**

SDLS053B – OCTOBER 1976 – REVISED MAY 2004

schematics of inputs and outputs

'147, '148

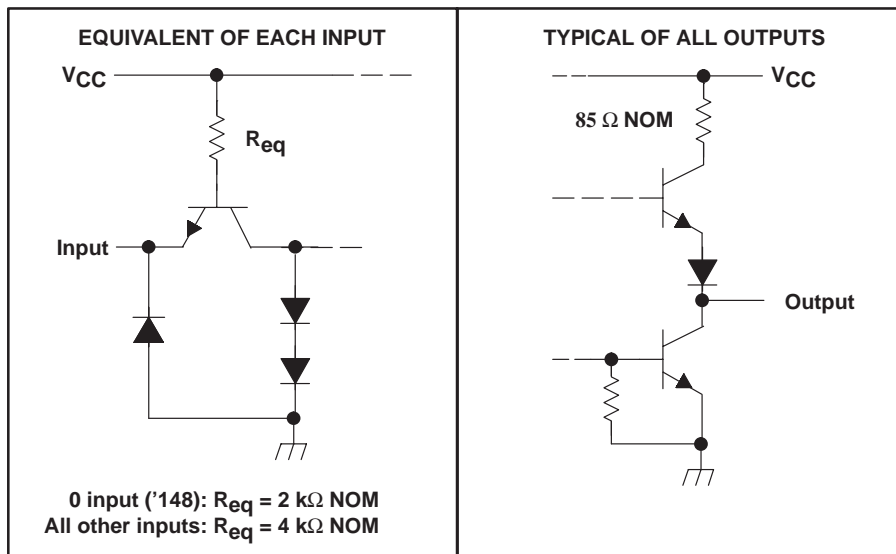

'LS147, 'LS148

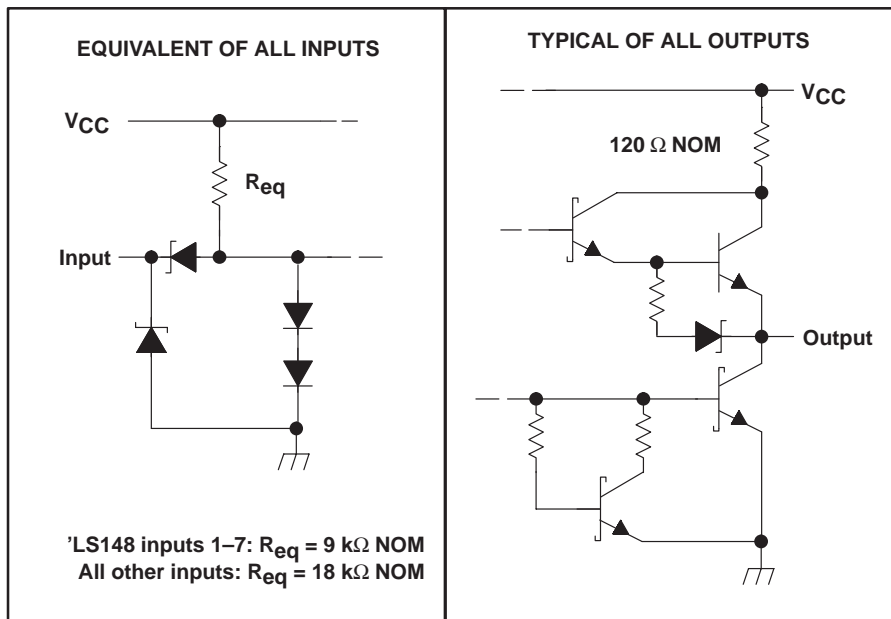

**SN54147, SN54148, SN54LS147, SN54LS148
SN74147, SN74148 (TIM9907), SN74LS147, SN74LS148
10-LINE TO 4-LINE AND 8-LINE TO 3-LINE PRIORITY ENCODERS**

SDLS053B – OCTOBER 1976 – REVISED MAY 2004

absolute maximum ratings over operating free-air temperature (unless otherwise noted)†

Supply voltage, V_{CC} (see Note 1)	7 V
Input voltage, V_I : '147, '148	5.5 V
'LS147, 'LS148	7 V
Inter-emitter voltage: '148 only (see Note 2)	5.5 V
Package thermal impedance θ_{JA} (see Note 3): D package	73°C/W
N package	67°C/W
NS package	64°C/W
Storage temperature range, T_{Stg}	–65°C to 150°C

† Stresses beyond those listed under “absolute maximum ratings” may cause permanent damage to the device. These are stress ratings only, and functional operation of the device at these or any other conditions beyond those indicated under “recommended operating conditions” is not implied. Exposure to absolute-maximum-rated conditions for extended periods may affect device reliability.

- NOTES:
1. Voltage values, except inter-emitter voltage, are with respect to the network ground terminal.
 2. This is the voltage between two emitters of a multiple-emitter transistor. For '148 circuits, this rating applies between any two of the eight data lines, 0 through 7.
 3. The package thermal impedance is calculated in accordance with JESD 51-7.

recommended operating conditions (see Note 4)

	SN54'			SN74'			SN54LS'			SN74LS'			UNIT
	MIN	NOM	MAX	MIN	NOM	MAX	MIN	NOM	MAX	MIN	NOM	MAX	
V_{CC} Supply voltage	4.5	5	5.5	4.75	5	5.25	4.5	5	5.5	4.75	5	5.25	V
I_{OH} High-level output current			–800			–800			–400			–400	μA
I_{OL} Low-level output current			16			16			4			8	mA
T_A Operating free-air temperature	–55		125	0		70	–55		125	0		70	°C

NOTE 4: All unused inputs of the device must be held at V_{CC} or GND to ensure proper device operation. Refer to the TI application report, *Implications of Slow or Floating CMOS Inputs*, literature number SCBA004.



**SN54147, SN54148, SN54LS147, SN54LS148
SN74147, SN74148 (TIM9907), SN74LS147, SN74LS148
10-LINE TO 4-LINE AND 8-LINE TO 3-LINE PRIORITY ENCODERS**

SDLS053B – OCTOBER 1976 – REVISED MAY 2004

electrical characteristics over recommended operating free-air temperature range (unless otherwise noted)

PARAMETER		TEST CONDITIONS†	'147			'148			UNIT
			MIN	TYP‡	MAX	MIN	TYP‡	MAX	
V _{IH}	High-level input voltage		2			2			V
V _{IL}	Low-level input voltage				0.8			0.8	V
V _{IK}	Input clamp voltage	V _{CC} = MIN, I _I = -12 mA			-1.5			-1.5	V
V _{OH}	High-level output voltage	V _{CC} = MIN, V _{IL} = 0.8 V, V _{IH} = 2 V, I _{OH} = -800 μA	2.4	3.3		2.4	3.3		V
V _{OL}	Low-level output voltage	V _{CC} = MIN, V _{IL} = 0.8 V, V _{IH} = 2 V, I _{OL} = 16 mA		0.2	0.4		0.2	0.4	V
I _I	Input current at maximum input voltage	V _{CC} = MIN, V _I = 5.5 V			1			1	mA
I _{IH}	High-level input current	0 input						40	μA
		Any input except 0	V _{CC} = MAX, V _I = 2.4 V		40			80	
I _{IL}	Low-level input current	0 input						-1.6	mA
		Any input except 0	V _{CC} = MAX, V _I = 0.4 V		-1.6			-3.2	
I _{OS}	Short-circuit output current§	V _{CC} = MAX	-35		-85	-35		-85	mA
I _{CC}	Supply current	V _{CC} = MAX (See Note 5)	Condition 1	50	70	40	60		mA
			Condition 2	42	62	35	55		

† For conditions shown as MIN or MAX, use the appropriate value specified under recommended operating conditions.

‡ All typical values are at V_{CC} = 5 V, T_A = 25°C.

§ Not more than one output should be shorted at a time.

NOTE 5: For '147, I_{CC} (Condition 1) is measured with input 7 grounded, other inputs and outputs open; I_{CC} (Condition 2) is measured with all inputs and outputs open. For '148, I_{CC} (Condition 1) is measured with inputs 7 and EI grounded, other inputs and outputs open; I_{CC} (Condition 2) is measured with all inputs and outputs open.

SN54147, SN74147 switching characteristics, V_{CC} = 5 V, T_A = 25°C (see Figure 1)

PARAMETER	FROM (INPUT)	TO (OUTPUT)	WAVEFORM	TEST CONDITIONS	MIN	TYP	MAX	UNIT
t _{PLH}	Any	Any	In-phase output	C _L = 15 pF, R _L = 400 Ω		9	14	ns
t _{PHL}						7	11	
t _{PLH}	Any	Any	Out-of-phase output			13	19	ns
t _{PHL}						12	19	



SN54147, SN54148, SN54LS147, SN54LS148
SN74147, SN74148 (TIM9907), SN74LS147, SN74LS148
10-LINE TO 4-LINE AND 8-LINE TO 3-LINE PRIORITY ENCODERS

SDLS053B – OCTOBER 1976 – REVISED MAY 2004

SN54148, SN74148 switching characteristics, $V_{CC} = 5\text{ V}$, $T_A = 25^\circ\text{C}$ (see Figure 1)

PARAMETER†	FROM (INPUT)	TO (OUTPUT)	WAVEFORM	TEST CONDITIONS	MIN	TYP	MAX	UNIT
t _{PLH}	1–7	A0, A1, or A2	In-phase output	C _L = 15 pF, R _L = 400 Ω	10	15	ns	
t _{PHL}								
t _{PLH}	1–7	A0, A1, or A2	Out-of-phase output		13	19	ns	
t _{PHL}								
t _{PLH}	0–7	EO	Out-of-phase output		6	10	ns	
t _{PHL}								
t _{PLH}	0–7	GS	In-phase output		18	30	ns	
t _{PHL}								
t _{PLH}	EI	A0, A1, or A2	In-phase output		10	15	ns	
t _{PHL}								
t _{PLH}	EI	GS	In-phase output		8	12	ns	
t _{PHL}								
t _{PLH}	EI	EO	In-phase output		10	15	ns	
t _{PHL}								

† t_{PLH} = propagation delay time, low-to-high-level output.
t_{PHL} = propagation delay time, high-to-low-level output.

electrical characteristics over recommended operating free-air temperature range (unless otherwise noted)

PARAMETER		TEST CONDITIONS†	SN54LS'		SN74LS'		UNIT	
			MIN	TYP‡	MAX	MIN		TYP‡
V _{IH}	High-level input voltage		2		2		V	
V _{IL}	Low-level input voltage			0.7		0.8	V	
V _{IK}	Input clamp voltage	V _{CC} = MIN, I _I = -18 mA		-1.5		-1.5	V	
V _{OH}	High-level output voltage	V _{CC} = MIN, V _{IL} = 0.8 V, I _{OH} = -400 μA	2.5	3.4	2.7	3.4	V	
V _{OL}	Low-level output voltage	V _{CC} = MIN, V _{IH} = 2 V, V _{IL} = V _{IL} MAX	I _{OL} = 4 mA		0.25	0.4	V	
			I _{OL} = 8 mA			0.35		0.5
I _I	Input current at maximum input voltage	'LS148 inputs 1–7	V _{CC} = MAX, V _I = 7 V		0.2		0.2	mA
		All other inputs			0.1		0.1	
I _{IH}	High-level input current	'LS148 inputs 1–7	V _{CC} = MAX, V _I = 2.7 V		40		40	μA
		All other inputs			20		20	
I _{IL}	Low-level input current	'LS148 inputs 1–7	V _{CC} = MAX, V _I = 0.4 V		-0.8		-0.8	mA
		All other inputs			-0.4		-0.4	
I _{OS}	Short-circuit output current§	V _{CC} = MAX	-20	-100	-20	-100	mA	
I _{CC}	Supply current	V _{CC} = MAX (See Note 6)	Condition 1		12	20	mA	
			Condition 2		10	17		

† For conditions shown as MIN or MAX, use the appropriate value specified under recommended operating conditions.

‡ All typical values are at V_{CC} = 5 V, T_A = 25°C.

§ Not more than one output should be shorted at a time.

NOTE 6: For 'LS147, I_{CC} (Condition 1) is measured with input 7 grounded, other inputs and outputs open; I_{CC} (Condition 2) is measured with all inputs and outputs open. For 'LS148, I_{CC} (Condition 1) is measured with inputs 7 and EI grounded, other inputs and outputs open; I_{CC} (Condition 2) is measured with all inputs and outputs open.



SN54147, SN54148, SN54LS147, SN54LS148
SN74147, SN74148 (TIM9907), SN74LS147, SN74LS148
10-LINE TO 4-LINE AND 8-LINE TO 3-LINE PRIORITY ENCODERS

SDLS053B – OCTOBER 1976 – REVISED MAY 2004

SN54LS147, SN74LS147 switching characteristics, $V_{CC} = 5\text{ V}$, $T_A = 25^\circ\text{C}$ (see Figure 2)

PARAMETER	FROM (INPUT)	TO (OUTPUT)	WAVEFORM	TEST CONDITIONS	MIN	TYP	MAX	UNIT
t_{PLH}	Any	Any	In-phase output	$C_L = 15\text{ pF}$, $R_L = 2\text{ k}\Omega$	12	18	ns	
t_{PHL}					12	18		
t_{PLH}	Any	Any	Out-of-phase output		21	33	ns	
t_{PHL}					15	23		

SN54LS148, SN74LS148 switching characteristics, $V_{CC} = 5\text{ V}$, $T_A = 25^\circ\text{C}$ (see Figure 2)

PARAMETER†	FROM (INPUT)	TO (OUTPUT)	WAVEFORM	TEST CONDITIONS	MIN	TYP	MAX	UNIT
t_{PLH}	1–7	A0, A1, or A2	In-phase output	$C_L = 15\text{ pF}$, $R_L = 2\text{ k}\Omega$	14	18	ns	
t_{PHL}					15	25		
t_{PLH}	1–7	A0, A1, or A2	Out-of-phase output		20	36	ns	
t_{PHL}					16	29		
t_{PLH}	0–7	EO	Out-of-phase output		7	18	ns	
t_{PHL}					25	40		
t_{PLH}	0–7	GS	In-phase output		35	55	ns	
t_{PHL}					9	21		
t_{PLH}	EI	A0, A1, or A2	In-phase output		16	25	ns	
t_{PHL}					12	25		
t_{PLH}	EI	GS	In-phase output		12	17	ns	
t_{PHL}					14	36		
t_{PLH}	EI	EO	In-phase output		12	21	ns	
t_{PHL}					23	35		

† t_{PLH} = propagation delay time, low-to-high-level output

t_{PHL} = propagation delay time, high-to-low-level output



SN54147, SN54148, SN54LS147, SN54LS148
SN74147, SN74148 (TIM9907), SN74LS147, SN74LS148
10-LINE TO 4-LINE AND 8-LINE TO 3-LINE PRIORITY ENCODERS

SDLS053B – OCTOBER 1976 – REVISED MAY 2004

PARAMETER MEASUREMENT INFORMATION
SERIES 54/74 DEVICES

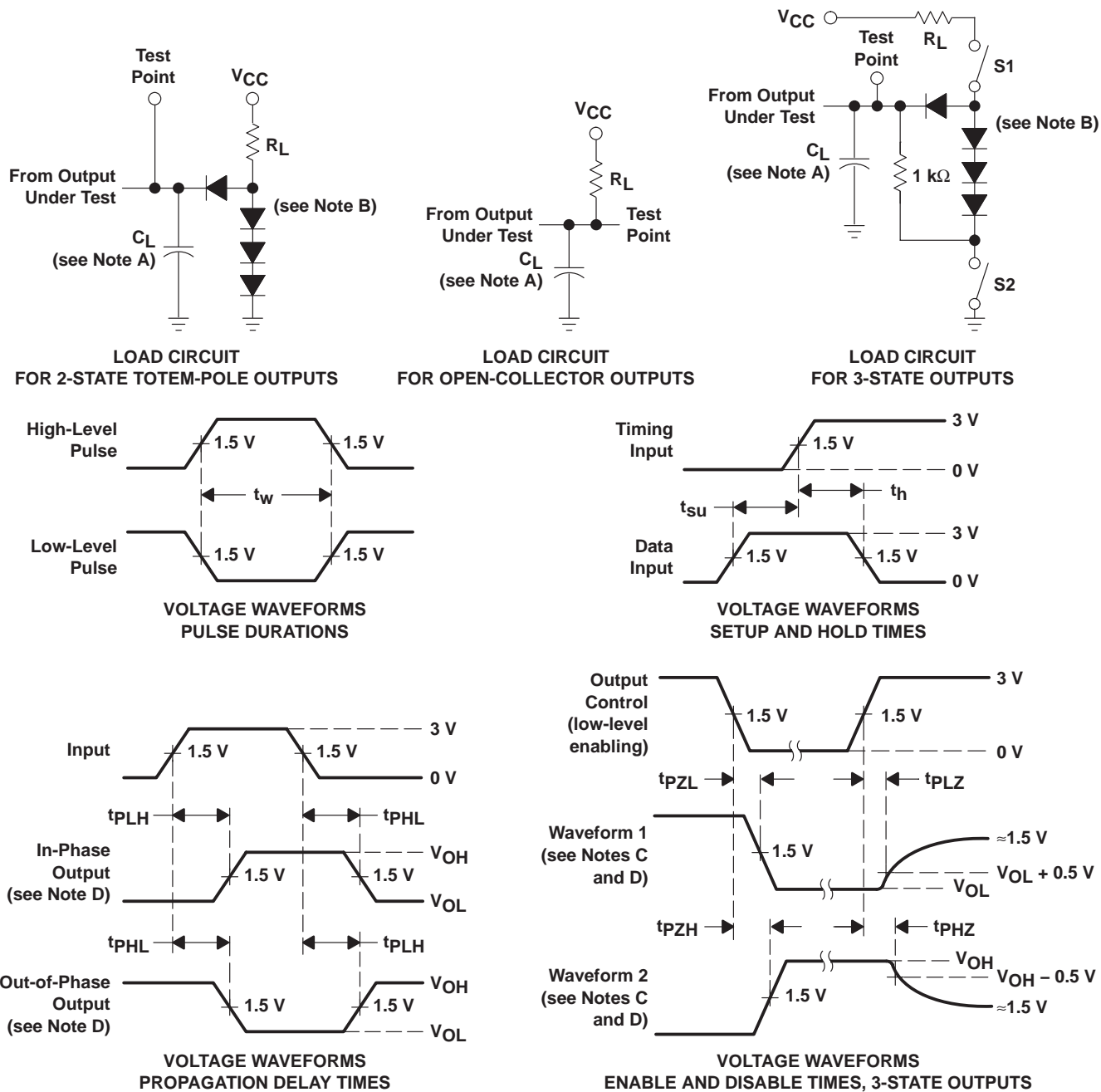

- NOTES:
- A. C_L includes probe and jig capacitance.
 - B. All diodes are 1N3064 or equivalent.
 - C. Waveform 1 is for an output with internal conditions such that the output is low, except when disabled by the output control. Waveform 2 is for an output with internal conditions such that the output is high, except when disabled by the output control.
 - D. S1 and S2 are closed for t_{PLH} , t_{PHL} , t_{PHZ} , and t_{PZL} ; S1 is open, and S2 is closed for t_{PZH} ; S1 is closed, and S2 is open for t_{PZL} .
 - E. All input pulses are supplied by generators having the following characteristics: $PRR \leq 1$ MHz, $Z_0 \approx 50 \Omega$; t_r and $t_f \leq 7$ ns for Series 54/74 devices and t_r and $t_f \leq 2.5$ ns for Series 54S/74S devices.
 - F. The outputs are measured one at a time, with one input transition per measurement.

Figure 1. Load Circuits and Voltage Waveforms

**SN54147, SN54148, SN54LS147, SN54LS148
SN74147, SN74148 (TIM9907), SN74LS147, SN74LS148
10-LINE TO 4-LINE AND 8-LINE TO 3-LINE PRIORITY ENCODERS**

SDLS053B – OCTOBER 1976 – REVISED MAY 2004

**PARAMETER MEASUREMENT INFORMATION
SERIES 54LS/74LS DEVICES**

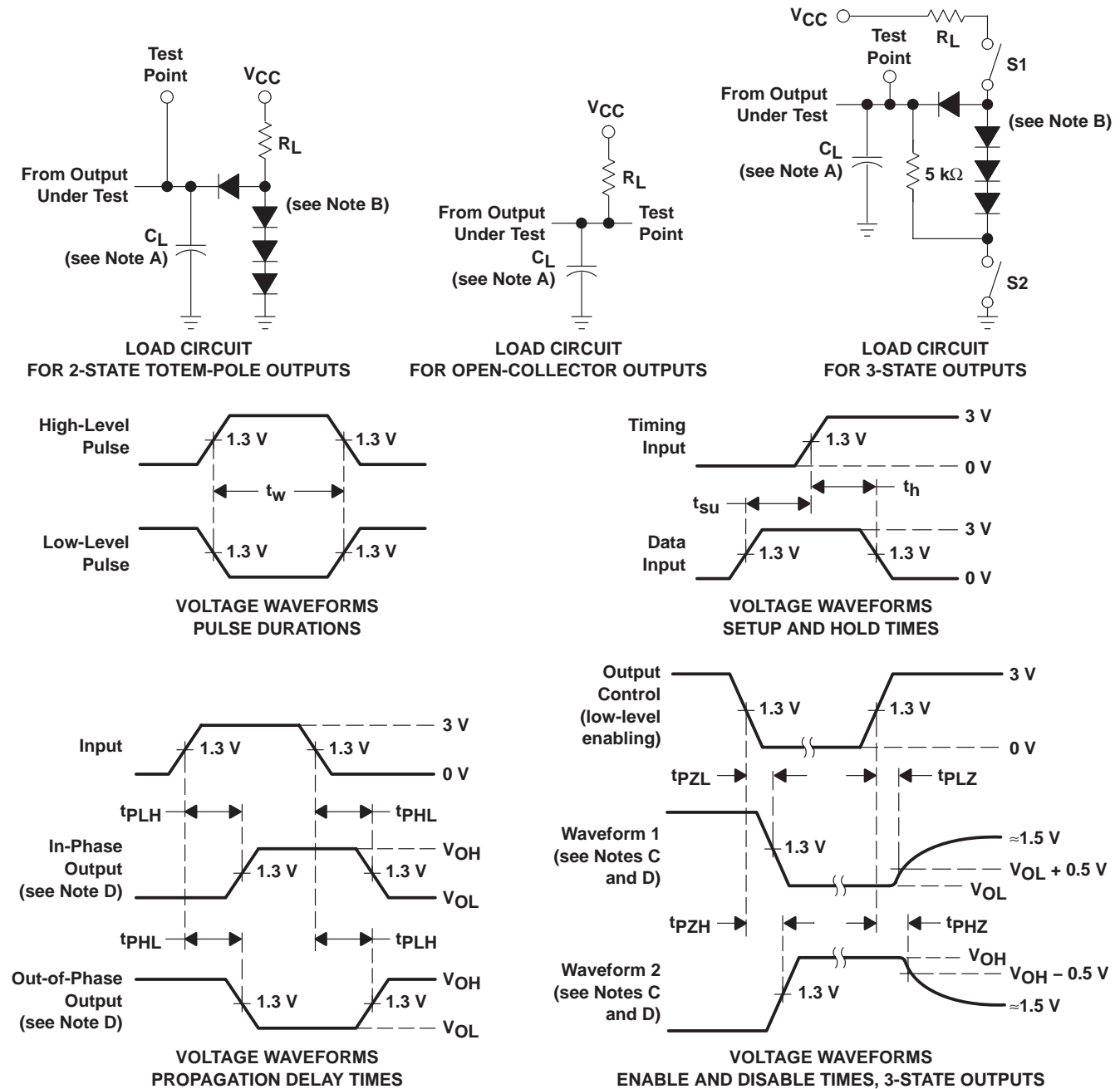

- NOTES: A. C_L includes probe and jig capacitance.
 B. All diodes are 1N3064 or equivalent.
 C. Waveform 1 is for an output with internal conditions such that the output is low, except when disabled by the output control. Waveform 2 is for an output with internal conditions such that the output is high, except when disabled by the output control.
 D. S1 and S2 are closed for t_{PLH} , t_{PHL} , t_{PHZ} , and t_{PZL} ; S1 is open, and S2 is closed for t_{PZH} ; S1 is closed, and S2 is open for t_{PZL} .
 E. Phase relationships between inputs and outputs have been chosen arbitrarily for these examples.
 F. All input pulses are supplied by generators having the following characteristics: $PRR \leq 1$ MHz, $Z_O \approx 50 \Omega$, $t_r \leq 1.5$ ns, $t_f \leq 2.6$ ns.
 G. The outputs are measured one at a time, with one input transition per measurement.

Figure 2. Load Circuits and Voltage Waveforms

**SN54147, SN54148, SN54LS147, SN54LS148
SN74147, SN74148 (TIM9907), SN74LS147, SN74LS148
10-LINE TO 4-LINE AND 8-LINE TO 3-LINE PRIORITY ENCODERS**

SDLS053B – OCTOBER 1976 – REVISED MAY 2004

APPLICATION INFORMATION

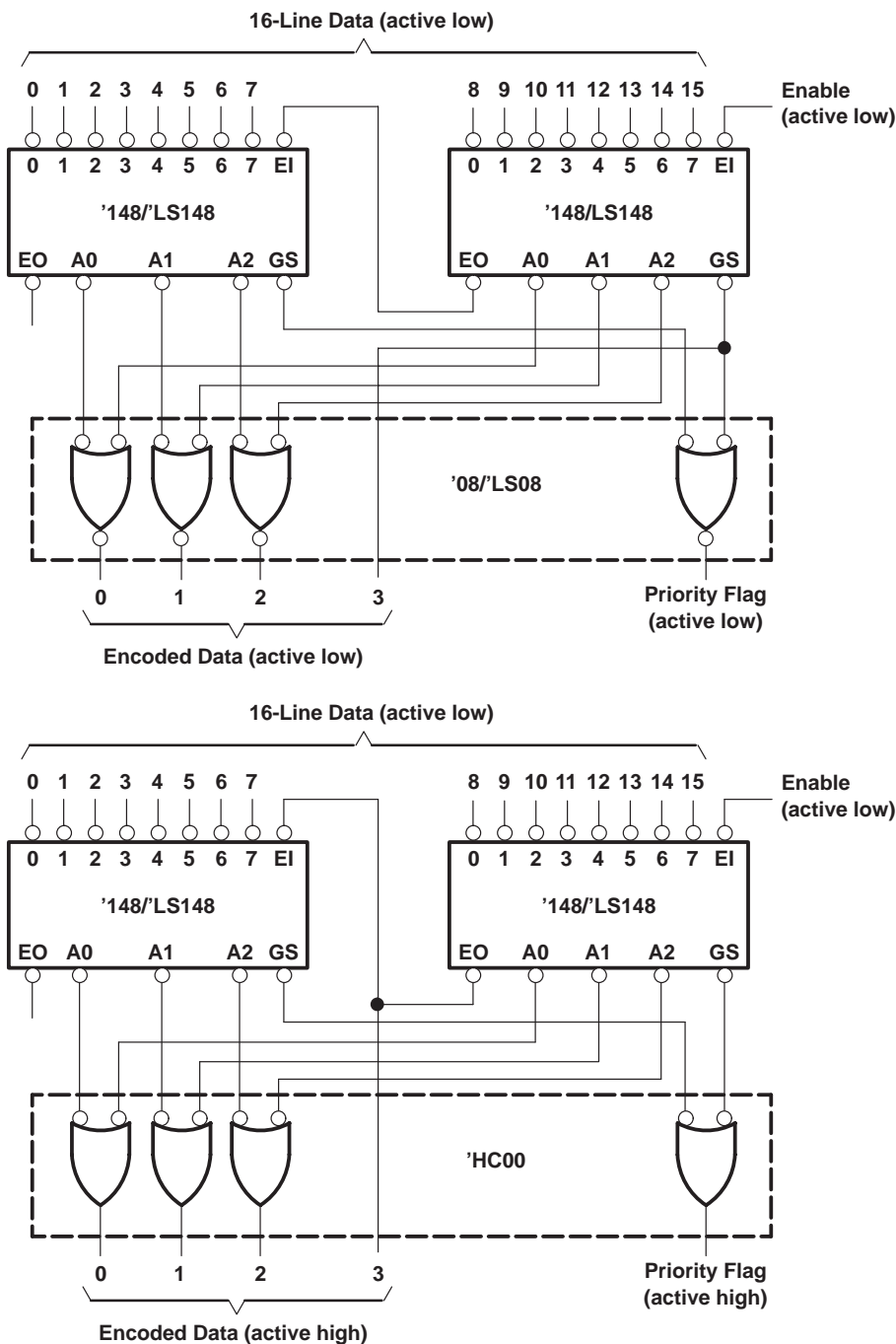

Figure 3. Priority Encoder for 16 Bits

Because the '147/LS147 and '148/LS148 devices are combinational logic circuits, wrong addresses can appear during input transients. Moreover, for the '148/LS148 devices, a change from high to low at EI can cause a transient low on GS when all inputs are high. This must be considered when strobing the outputs.

PACKAGING INFORMATION

Orderable Device	Status (1)	Package Type	Package Drawing	Pins	Package Qty	Eco Plan (2)	Lead finish/ Ball material (6)	MSL Peak Temp (3)	Op Temp (°C)	Device Marking (4/5)	Samples
78027012A	ACTIVE	LCCC	FK	20	55	Non-RoHS & Green	SNPB	N / A for Pkg Type	-55 to 125	78027012A SNJ54LS 148FK	Samples
7802701EA	ACTIVE	CDIP	J	16	25	Non-RoHS & Green	SNPB	N / A for Pkg Type	-55 to 125	7802701EA SNJ54LS148J	Samples
7802701FA	ACTIVE	CFP	W	16	25	Non-RoHS & Green	SNPB	N / A for Pkg Type	-55 to 125	7802701FA SNJ54LS148W	Samples
JM38510/36001B2A	ACTIVE	LCCC	FK	20	55	Non-RoHS & Green	SNPB	N / A for Pkg Type	-55 to 125	JM38510/ 36001B2A	Samples
JM38510/36001BEA	ACTIVE	CDIP	J	16	25	Non-RoHS & Green	SNPB	N / A for Pkg Type	-55 to 125	JM38510/ 36001BEA	Samples
JM38510/36001BFA	ACTIVE	CFP	W	16	25	Non-RoHS & Green	SNPB	N / A for Pkg Type	-55 to 125	JM38510/ 36001BFA	Samples
M38510/36001B2A	ACTIVE	LCCC	FK	20	55	Non-RoHS & Green	SNPB	N / A for Pkg Type	-55 to 125	JM38510/ 36001B2A	Samples
M38510/36001BEA	ACTIVE	CDIP	J	16	25	Non-RoHS & Green	SNPB	N / A for Pkg Type	-55 to 125	JM38510/ 36001BEA	Samples
M38510/36001BFA	ACTIVE	CFP	W	16	25	Non-RoHS & Green	SNPB	N / A for Pkg Type	-55 to 125	JM38510/ 36001BFA	Samples
SN54LS148J	ACTIVE	CDIP	J	16	25	Non-RoHS & Green	SNPB	N / A for Pkg Type	-55 to 125	SN54LS148J	Samples
SN74LS148D	OBSOLETE	SOIC	D	16		TBD	Call TI	Call TI	0 to 70	LS148	
SN74LS148DR	ACTIVE	SOIC	D	16	2500	RoHS & Green	NIPDAU	Level-1-260C-UNLIM	0 to 70	LS148	Samples
SN74LS148N	ACTIVE	PDIP	N	16	25	RoHS & Green	NIPDAU	N / A for Pkg Type	0 to 70	SN74LS148N	Samples
SN74LS148NSR	ACTIVE	SO	NS	16	2000	RoHS & Green	NIPDAU	Level-1-260C-UNLIM	0 to 70	74LS148	Samples
SNJ54LS148FK	ACTIVE	LCCC	FK	20	55	Non-RoHS & Green	SNPB	N / A for Pkg Type	-55 to 125	78027012A SNJ54LS 148FK	Samples
SNJ54LS148J	ACTIVE	CDIP	J	16	25	Non-RoHS & Green	SNPB	N / A for Pkg Type	-55 to 125	7802701EA SNJ54LS148J	Samples
SNJ54LS148W	ACTIVE	CFP	W	16	25	Non-RoHS & Green	SNPB	N / A for Pkg Type	-55 to 125	7802701FA SNJ54LS148W	Samples

(1) The marketing status values are defined as follows:

ACTIVE: Product device recommended for new designs.

LIFEBUY: TI has announced that the device will be discontinued, and a lifetime-buy period is in effect.

NRND: Not recommended for new designs. Device is in production to support existing customers, but TI does not recommend using this part in a new design.

PREVIEW: Device has been announced but is not in production. Samples may or may not be available.

OBSOLETE: TI has discontinued the production of the device.

(2) **RoHS:** TI defines "RoHS" to mean semiconductor products that are compliant with the current EU RoHS requirements for all 10 RoHS substances, including the requirement that RoHS substance do not exceed 0.1% by weight in homogeneous materials. Where designed to be soldered at high temperatures, "RoHS" products are suitable for use in specified lead-free processes. TI may reference these types of products as "Pb-Free".

RoHS Exempt: TI defines "RoHS Exempt" to mean products that contain lead but are compliant with EU RoHS pursuant to a specific EU RoHS exemption.

Green: TI defines "Green" to mean the content of Chlorine (Cl) and Bromine (Br) based flame retardants meet JS709B low halogen requirements of ≤ 1000 ppm threshold. Antimony trioxide based flame retardants must also meet the ≤ 1000 ppm threshold requirement.

(3) MSL, Peak Temp. - The Moisture Sensitivity Level rating according to the JEDEC industry standard classifications, and peak solder temperature.

(4) There may be additional marking, which relates to the logo, the lot trace code information, or the environmental category on the device.

(5) Multiple Device Markings will be inside parentheses. Only one Device Marking contained in parentheses and separated by a "~" will appear on a device. If a line is indented then it is a continuation of the previous line and the two combined represent the entire Device Marking for that device.

(6) Lead finish/Ball material - Orderable Devices may have multiple material finish options. Finish options are separated by a vertical ruled line. Lead finish/Ball material values may wrap to two lines if the finish value exceeds the maximum column width.

Important Information and Disclaimer: The information provided on this page represents TI's knowledge and belief as of the date that it is provided. TI bases its knowledge and belief on information provided by third parties, and makes no representation or warranty as to the accuracy of such information. Efforts are underway to better integrate information from third parties. TI has taken and continues to take reasonable steps to provide representative and accurate information but may not have conducted destructive testing or chemical analysis on incoming materials and chemicals. TI and TI suppliers consider certain information to be proprietary, and thus CAS numbers and other limited information may not be available for release.

In no event shall TI's liability arising out of such information exceed the total purchase price of the TI part(s) at issue in this document sold by TI to Customer on an annual basis.

OTHER QUALIFIED VERSIONS OF SN54LS148, SN74LS148 :

● Catalog : [SN74LS148](#)

● Military : [SN54LS148](#)

NOTE: Qualified Version Definitions:

- Catalog - TI's standard catalog product
- Military - QML certified for Military and Defense Applications

TAPE AND REEL INFORMATION



QUADRANT ASSIGNMENTS FOR PIN 1 ORIENTATION IN TAPE



*All dimensions are nominal

Device	Package Type	Package Drawing	Pins	SPQ	Reel Diameter (mm)	Reel Width W1 (mm)	A0 (mm)	B0 (mm)	K0 (mm)	P1 (mm)	W (mm)	Pin1 Quadrant
SN74LS148DR	SOIC	D	16	2500	330.0	16.4	6.5	10.3	2.1	8.0	16.0	Q1
SN74LS148NSR	SO	NS	16	2000	330.0	16.4	8.2	10.5	2.5	12.0	16.0	Q1

TAPE AND REEL BOX DIMENSIONS

*All dimensions are nominal

Device	Package Type	Package Drawing	Pins	SPQ	Length (mm)	Width (mm)	Height (mm)
SN74LS148DR	SOIC	D	16	2500	340.5	336.1	32.0
SN74LS148NSR	SO	NS	16	2000	367.0	367.0	38.0

TUBE

*All dimensions are nominal

Device	Package Name	Package Type	Pins	SPQ	L (mm)	W (mm)	T (μm)	B (mm)
78027012A	FK	LCCC	20	55	506.98	12.06	2030	NA
7802701FA	W	CFP	16	25	506.98	26.16	6220	NA
JM38510/36001B2A	FK	LCCC	20	55	506.98	12.06	2030	NA
JM38510/36001BFA	W	CFP	16	25	506.98	26.16	6220	NA
M38510/36001B2A	FK	LCCC	20	55	506.98	12.06	2030	NA
M38510/36001BFA	W	CFP	16	25	506.98	26.16	6220	NA
SN74LS148N	N	PDIP	16	25	506	13.97	11230	4.32
SN74LS148N	N	PDIP	16	25	506	13.97	11230	4.32
SNJ54LS148FK	FK	LCCC	20	55	506.98	12.06	2030	NA
SNJ54LS148W	W	CFP	16	25	506.98	26.16	6220	NA



PACKAGE OUTLINE

NS0016A

SOP - 2.00 mm max height

SOP



4220735/A 12/2021

NOTES:

1. All linear dimensions are in millimeters. Dimensions in parenthesis are for reference only. Dimensioning and tolerancing per ASME Y14.5M.
2. This drawing is subject to change without notice.
3. This dimension does not include mold flash, protrusions, or gate burrs. Mold flash, protrusions, or gate burrs shall not exceed 0.15 mm, per side.
4. This dimension does not include interlead flash. Interlead flash shall not exceed 0.25 mm, per side.

EXAMPLE BOARD LAYOUT

NS0016A

SOP - 2.00 mm max height

SOP



4220735/A 12/2021

NOTES: (continued)

5. Publication IPC-7351 may have alternate designs.

6. Solder mask tolerances between and around signal pads can vary based on board fabrication site.

EXAMPLE STENCIL DESIGN

NS0016A

SOP - 2.00 mm max height

SOP



SOLDER PASTE EXAMPLE
BASED ON 0.125 mm THICK STENCIL
SCALE:7X

4220735/A 12/2021

NOTES: (continued)

7. Laser cutting apertures with trapezoidal walls and rounded corners may offer better paste release. IPC-7525 may have alternate design recommendations.
8. Board assembly site may have different recommendations for stencil design.

D (R-PDSO-G16)

PLASTIC SMALL OUTLINE



- NOTES:
- A. All linear dimensions are in inches (millimeters).
 - B. This drawing is subject to change without notice.
 - C. Body length does not include mold flash, protrusions, or gate burrs. Mold flash, protrusions, or gate burrs shall not exceed 0.006 (0,15) each side.
 - D. Body width does not include interlead flash. Interlead flash shall not exceed 0.017 (0,43) each side.
 - E. Reference JEDEC MS-012 variation AC.

MECHANICAL DATA

NS (R-PDSO-G**)

PLASTIC SMALL-OUTLINE PACKAGE

14-PINS SHOWN



- NOTES:
- A. All linear dimensions are in millimeters.
 - B. This drawing is subject to change without notice.
 - C. Body dimensions do not include mold flash or protrusion, not to exceed 0,15.

W (R-GDFP-F16)

CERAMIC DUAL FLATPACK

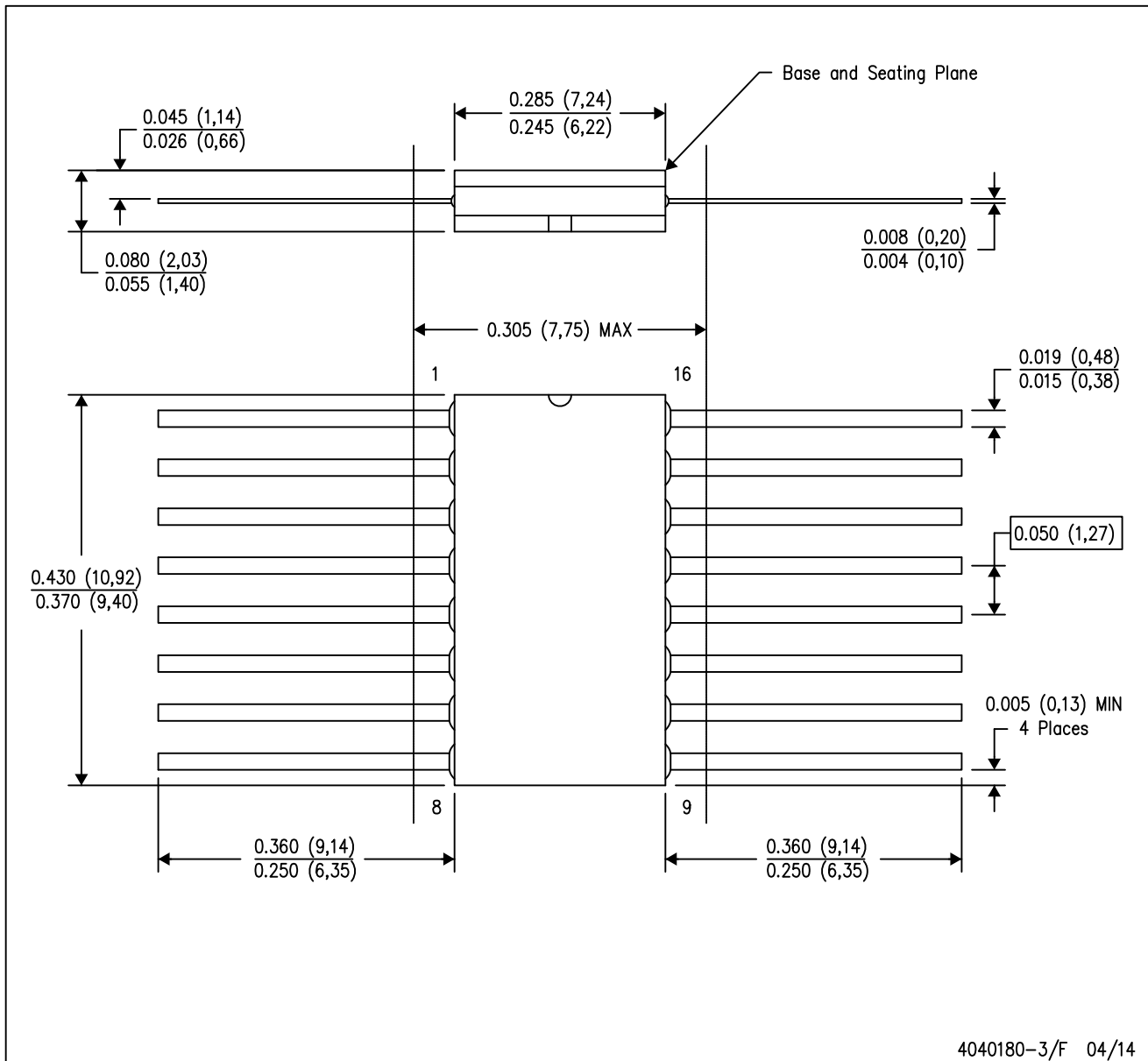

- NOTES:
- A. All linear dimensions are in inches (millimeters).
 - B. This drawing is subject to change without notice.
 - C. This package can be hermetically sealed with a ceramic lid using glass frit.
 - D. Index point is provided on cap for terminal identification only.
 - E. Falls within MIL STD 1835 GDFP2-F16

GENERIC PACKAGE VIEW

FK 20

LCCC - 2.03 mm max height

8.89 x 8.89, 1.27 mm pitch

LEADLESS CERAMIC CHIP CARRIER

This image is a representation of the package family, actual package may vary.
Refer to the product data sheet for package details.



4229370VA\

J (R-GDIP-T**)

14 LEADS SHOWN

CERAMIC DUAL IN-LINE PACKAGE



DIM \ PINS **	14	16	18	20
A	0.300 (7,62) BSC	0.300 (7,62) BSC	0.300 (7,62) BSC	0.300 (7,62) BSC
B MAX	0.785 (19,94)	.840 (21,34)	0.960 (24,38)	1.060 (26,92)
B MIN	—	—	—	—
C MAX	0.300 (7,62)	0.300 (7,62)	0.310 (7,87)	0.300 (7,62)
C MIN	0.245 (6,22)	0.245 (6,22)	0.220 (5,59)	0.245 (6,22)



4040083/F 03/03

- NOTES:
- All linear dimensions are in inches (millimeters).
 - This drawing is subject to change without notice.
 - This package is hermetically sealed with a ceramic lid using glass frit.
 - Index point is provided on cap for terminal identification only on press ceramic glass frit seal only.
 - Falls within MIL STD 1835 GDIP1-T14, GDIP1-T16, GDIP1-T18 and GDIP1-T20.

N (R-PDIP-T**)

PLASTIC DUAL-IN-LINE PACKAGE

16 PINS SHOWN



- NOTES:
- A. All linear dimensions are in inches (millimeters).
 - B. This drawing is subject to change without notice.
 - $\triangle C$ Falls within JEDEC MS-001, except 18 and 20 pin minimum body length (Dim A).
 - $\triangle D$ The 20 pin end lead shoulder width is a vendor option, either half or full width.

IMPORTANT NOTICE AND DISCLAIMER

TI PROVIDES TECHNICAL AND RELIABILITY DATA (INCLUDING DATA SHEETS), DESIGN RESOURCES (INCLUDING REFERENCE DESIGNS), APPLICATION OR OTHER DESIGN ADVICE, WEB TOOLS, SAFETY INFORMATION, AND OTHER RESOURCES "AS IS" AND WITH ALL FAULTS, AND DISCLAIMS ALL WARRANTIES, EXPRESS AND IMPLIED, INCLUDING WITHOUT LIMITATION ANY IMPLIED WARRANTIES OF MERCHANTABILITY, FITNESS FOR A PARTICULAR PURPOSE OR NON-INFRINGEMENT OF THIRD PARTY INTELLECTUAL PROPERTY RIGHTS.

These resources are intended for skilled developers designing with TI products. You are solely responsible for (1) selecting the appropriate TI products for your application, (2) designing, validating and testing your application, and (3) ensuring your application meets applicable standards, and any other safety, security, regulatory or other requirements.

These resources are subject to change without notice. TI grants you permission to use these resources only for development of an application that uses the TI products described in the resource. Other reproduction and display of these resources is prohibited. No license is granted to any other TI intellectual property right or to any third party intellectual property right. TI disclaims responsibility for, and you will fully indemnify TI and its representatives against, any claims, damages, costs, losses, and liabilities arising out of your use of these resources.

TI's products are provided subject to [TI's Terms of Sale](#) or other applicable terms available either on [ti.com](https://www.ti.com) or provided in conjunction with such TI products. TI's provision of these resources does not expand or otherwise alter TI's applicable warranties or warranty disclaimers for TI products.

TI objects to and rejects any additional or different terms you may have proposed.

Mailing Address: Texas Instruments, Post Office Box 655303, Dallas, Texas 75265
Copyright © 2024, Texas Instruments Incorporated