

SN65HVD23x 3.3V CANバス・トランシーバ

1 特長

- 3.3V単一電源
- バス・ピンのフォルト保護: $\pm 36V$ 超
- バス・ピンのESD保護: $\pm 16kV$ 超、HBM
- ISO 11898-2準拠
- GIFT/ICT準拠
- 最高1Mbpsのデータ速度
- 広い同相電圧範囲: $-7V \sim 12V$
- 高い入力インピーダンスにより120ノードが可能
- LVTTTL I/Oは5V許容
- ドライバ遷移時間が可変なため放射特性が向上
- 電力オフのノードはバスに干渉
- 低電流のスタンバイ・モード: 200 μA (標準値)
- SN65HVD233: ループバック・モード
- SN65HVD234: 超低電流のスリープ・モード
 - 標準消費電流: 50nA
- SN65HVD235: オートポーのループバック・モード
- サーマル・シャットダウン保護機能
- グリッチ・フリーのバス入力および出力による電源オンおよびオフ
 - 高い入力インピーダンスと低い V_{CC}
 - 電源サイクル中のモノリシック出力

2 アプリケーション

- 産業オートメーション、制御、センサ、駆動システム
- モータおよびロボット制御
- ビルディングおよび空調制御(HVAC)
- バックプレーン通信および制御
- CANopen、DeviceNet、CAN Kingdom、NMEA 2000、SAE J1939などのCANバス標準

3 概要

SN65HVD233、SN65HVD234、SN65HVD235は、ISO 11898標準に準拠したCAN (Controller Area Network) シリアル通信の物理レイヤを採用しているアプリケーションで使用されます。各デバイスはCANトランシーバとして、最高1Mbpsの信号速度で、差動CANバスとCANコントローラとの間の送受信を実行する機能を備えています。

これらのデバイスは、非常に過酷な環境で動作するように設計されており、クロスワイヤ保護、 $\pm 36V$ までの過電圧保護、グランド消失保護、過熱保護(サーマル・シャットダウン)、 $\pm 100V$ の同相過渡保護の機能があります。これらのデバイスは、 $-7V \sim 12V$ の広い同相電圧範囲で動作します。これらのトランシーバは、マイクロプロセッサ上のホストCANコントローラと、産業用、ビルディング・オートメーション、輸送機関、車載用のアプリケーションで使用される差動CANバスとの間のインターフェイスです。

製品情報(1)

型番	パッケージ	本体サイズ(公称)
SN65HVD233	SOIC (8)	4.90mmx3.91mm
SN65HVD234		
SN65HVD235		

(1) 利用可能なすべてのパッケージについては、このデータシートの末尾にある注文情報を参照してください。

ブロック図

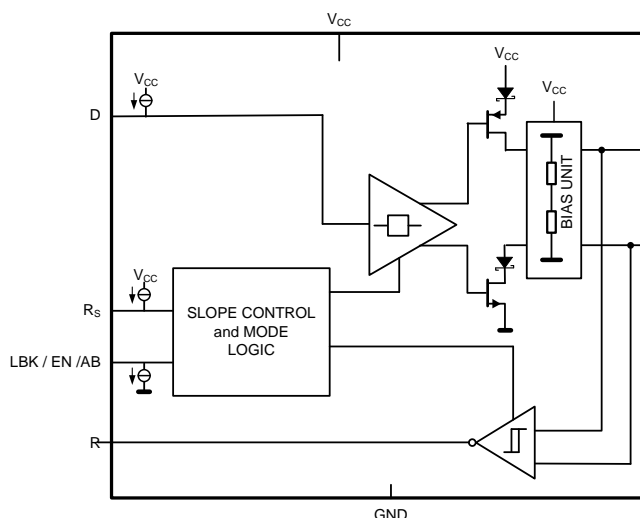

目次

1	特長	1	10	Detailed Description	19
2	アプリケーション	1	10.1	Overview	19
3	概要	1	10.2	Functional Block Diagrams	19
4	改訂履歴	2	10.3	Feature Description	19
5	概要 (続き)	4	10.4	Device Functional Modes	21
6	Device Comparison Table	4	11	Application and Implementation	23
7	Pin Configuration and Functions	5	11.1	Application Information	23
8	Specifications	5	11.2	Typical Application	24
8.1	Absolute Maximum Ratings	5	11.3	System Example	26
8.2	ESD Ratings	6	12	Power Supply Recommendations	28
8.3	Recommended Operating Conditions	6	13	Layout	28
8.4	Thermal Information	6	13.1	Layout Guidelines	28
8.5	Power Dissipation Ratings	6	13.2	Layout Example	29
8.6	Electrical Characteristics: Driver	7	14	デバイスおよびドキュメントのサポート	30
8.7	Electrical Characteristics: Receiver	8	14.1	関連リンク	30
8.8	Switching Characteristics: Driver	8	14.2	ドキュメントの更新通知を受け取る方法	30
8.9	Switching Characteristics: Receiver	9	14.3	コミュニティ・リソース	30
8.10	Switching Characteristics: Device	9	14.4	商標	30
8.11	Typical Characteristics	10	14.5	静電気放電に関する注意事項	30
9	Parameter Measurement Information	12	14.6	Glossary	30
			15	メカニカル、パッケージ、および注文情報	30

4 改訂履歴

資料番号末尾の英字は改訂を表しています。その改訂履歴は英語版に準じています。

Revision G (January 2015) から Revision H に変更 Page

- 「アプリケーション」の最後の箇条書き項目から「ISO 11783」を削除

Revision F (August 2008) から Revision G に変更 Page

- 「ピン構成および機能」セクション、「ESD定格」表、「機能説明」セクション、「デバイスの機能モード」セクション、「アプリケーションと実装」セクション、「電源に関する推奨事項」セクション、「レイアウト」セクション、「デバイスおよびドキュメントのサポート」セクション、「メカニカル、パッケージ、および注文情報」セクション 追加
- Changed the Functional Block Diagrams
- Added the THERMAL SHUTDOWN paragraph to the Application Information section
- Changed the BUS CABLE paragraph to BUS LOADING, LENGTH AND NUMBER OF NODES paragraph in the Application Information section
- Added the CAN TERMINATION paragraph to the Application Information section

Revision E (October 2007) から Revision F に変更 Page

- Changed [Figure 17](#), Receiver Test Circuit and Voltage Waveform. From: $C_L = 50 \text{ pF} \pm 20\%$ to: $C_L = 15 \text{ pF} \pm 20\%$

Revision D (June 2005) から Revision E に変更 Page

- Added 60- Ω load test condition to [Figure 3](#)
- Deleted INTEROPERABILITY WITH 5-V CAN SYSTEMS section
- Added ISO 11898 COMPLIANCE OF SN65HVD230 FAMILY OF 3.3-V CAN TRANSCEIVERS section

Revision C (March 2005) から Revision D に変更 **Page**

- 「特長」の箇条書きに「GIFT/ICT準拠」を(SN65HVD234) 追加 1
-

Revision B (June 2003) から Revision C に変更 **Page**

- Added $I_{O, Receiver}$ output current to the Abs Max Table 5
-

Revision A (March 2003) から Revision B に変更 **Page**

- 型番SN65HVD234およびSN65HVD235について、データシートを「製品プレビュー」から「量産」に変更 1
 - Changed the APPLICATION INFORMATION section..... 23
-

2002年11月発行のものから更新 **Page**

- 型番SN65HVD233について、データシートを「製品プレビュー」から「量産」に変更 1
-

5 概要 (続き)

モード: SN65HVD233, SN65HVD234, SN65HVD235 デバイスの R_S ピン (ピン8) で、高速、勾配制御、低消費電力スタンバイ・モードの3つの動作モードを選択できます。ピン8を直接グランドへ接続すると高速モードの動作が選択され、ドライブ出力トランジスタは立ち上がり立ち下がり勾配の制限なしに、可能な限り高速にオン/オフのスイッチングを行います。立ち上がり立ち下がり勾配は、 R_S ピンとグランドとの間に抵抗を接続して調整できます。この勾配は、ピンの出力電流に比例します。抵抗値が10k Ω の場合、デバイス・ドライバのスルーレートは約15V/ μ sで、抵抗の値が100k Ω なら、デバイスのスルーレートは約2.0V/ μ sです。勾配制御の詳細については、「[機能説明](#)」セクションを参照してください。

SN65HVD233, SN65HVD234, SN65HVD235は、 R_S ピンにHIGHロジック・レベルが印加されると、低電流のスタンバイ (リッスンのみ) モードへ移行し、このモードでは、ドライバのスイッチがオフになり、レシーバはアクティブのまま保持されます。ローカル・プロトコル・コントローラがバスにメッセージを送信する必要がある場合、 R_S ピンを使用して、デバイスを高速モードまたは勾配制御モードに戻す必要があります。

ループバック(SN65HVD233): SN65HVD233のループバック(LBK)ピン (ピン5) がロジックHIGHになると、バス出力とバス入力が高インピーダンス状態になります。内部的には、デバイスのDからRへのバスはアクティブに維持され、ドライブからレシーバへのループバックに使用可能で、これによりバスに干渉しない自己診断ノード機能として使用できます。ループバック・モード機能の詳細については、「[機能説明](#)」セクションを参照してください。

超低電流スリープ(SN65HVD234): SN65HVD234は、ENピン (ピン5) にロジックLOWレベルが印加されると、超低電流スリープ・モードになり、ドライバとレシーバの両方の回路が非アクティブになります。デバイスは、ピン5にロジックHIGHレベルが印加されて回路が再度アクティブになるまで、このスリープ・モードに維持されます。

オートボー・ループバック(SN65HVD235): SN65HVD235 デバイスのABピン (ピン5) にはバス・リッスンのためのループバック機能が実装されており、ローカル・ノード・コントローラのボーレートをCANバスのもと同期できます。オートボー・モードでは、ドライバのバス出力は高インピーダンス状態になり、レシーバのバス入力はアクティブ状態に維持されます。コントローラのボーレート検出やオートボー機能を補助するため、内部的にDピンからRピンへのループバックがあります。オートボー・モードの詳細については、「[機能説明](#)」セクションを参照してください。

6 Device Comparison Table⁽¹⁾

PART NUMBER	LOW POWER MODE	SLOPE CONTROL	DIAGNOSTIC LOOPBACK	AUTOBAUD LOOPBACK
SN65HVD233D	200- μ A standby mode	Adjustable	Yes	No
SN65HVD234D	200- μ A standby mode or 50-nA sleep mode	Adjustable	No	No
SN65HVD235D	200- μ A standby mode	Adjustable	No	Yes

(1) For the most current package and ordering information, see [メカニカル](#)、[パッケージ](#)、[および注文情報](#)、or see the TI web site at www.ti.com.

7 Pin Configuration and Functions

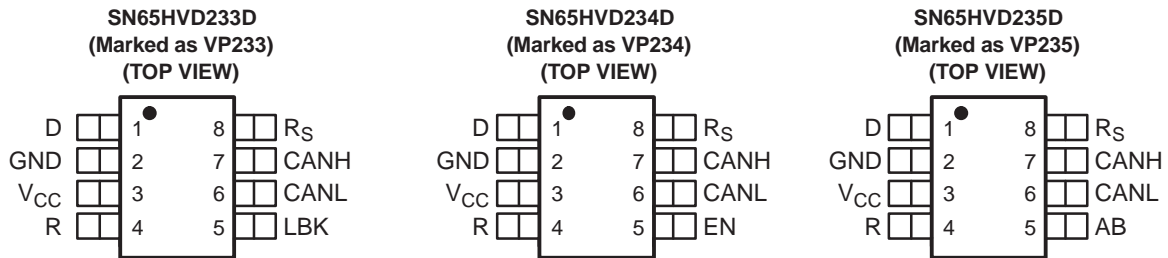

Pin Functions

PIN		TYPE	DESCRIPTION
NAME	NO.		
D	1	I	CAN transmit data input (LOW for dominant and HIGH for recessive bus states), also called TXD, driver input
GND	2	GND	Ground connection
V _{CC}	3	Supply	Transceiver 3.3-V supply voltage
R	4	O	CAN receive data output (LOW for dominant and HIGH for recessive bus states), also called RXD, receiver output
LBK	5	I	SN65HVD233: Loopback mode input pin
EN		I	SN65HVD234: Enable input pin. Logic high for enabling a normal mode (high speed or slope control) mode. Logic low for sleep mode.
AB		I	SN65HVD235: Autobaud loopback mode input pin
CANL	6	I/O	Low level CAN bus line
CANH	7	I/O	High level CAN bus line
R _S	8	I	Mode select pin: strong pulldown to GND = high speed mode, strong pullup to V _{CC} = low power mode, 10-kΩ to 100-kΩ pulldown to GND = slope control mode

8 Specifications

8.1 Absolute Maximum Ratings⁽¹⁾⁽²⁾

over operating free-air temperature range unless otherwise noted

	MIN	MAX	UNIT
V _{CC} Supply voltage	-0.3	7	V
Voltage at any bus terminal (CANH or CANL)	-36	36	V
Voltage input, transient pulse, CANH and CANL, through 100 Ω (see Figure 18)	-100	100	V
V _I Input voltage, (D, R _S , EN, LBK, AB)	-0.5	7	V
V _O Output voltage	-0.5	7	V
I _O Receiver output current	-10	10	mA
Continuous total power dissipation	See Power Dissipation Ratings		
T _J Operating junction temperature			150
T _{stg} Storage temperature			125

- (1) Stresses beyond those listed under *Absolute Maximum Ratings* may cause permanent damage to the device. These are stress ratings only, and functional operation of the device at these or any other conditions beyond those indicated under *Recommended Operating Conditions* is not implied. Exposure to absolute-maximum-rated conditions for extended periods may affect device reliability.
- (2) All voltage values, except differential I/O bus voltages, are with respect to network ground pin.

8.2 ESD Ratings

			VALUE	UNIT	
$V_{(ESD)}$	Electrostatic discharge	Human body model (HBM), per ANSI/ESDA/JEDEC JS-001 ⁽¹⁾	CANH, CANL and GND	±16000	V
			All pins	3000	
		Charged-device model (CDM), per JEDEC specification JESD22-C101 ⁽²⁾		±1000	

(1) JEDEC document JEP155 states that 500-V HBM allows safe manufacturing with a standard ESD control process.

(2) JEDEC document JEP157 states that 250-V CDM allows safe manufacturing with a standard ESD control process.

8.3 Recommended Operating Conditions

			MIN	MAX	UNIT
V_{CC}	Supply voltage		3	3.6	V
	Voltage at any bus terminal (separately or common mode)		-7	12	
V_{IH}	High-level input voltage	D, EN, AB, LBK	2	5.5	V
V_{IL}	Low-level input voltage	D, EN, AB, LBK	0	0.8	
V_{ID}	Differential input voltage between CANH and CANL		-6	6	kΩ
	Resistance from R_S to ground		0	100	
$V_{I(RS)}$	Input Voltage at R_S for standby		0.75 V_{CC}	5.5	V
I_{OH}	High-level output current	Driver	-50		mA
		Receiver	-10		
I_{OL}	Low-level output current	Driver		50	mA
		Receiver		10	
T_J	Operating junction temperature	HVD233, HVD234, HVD235		150	°C
T_A	Operating free-air temperature ⁽¹⁾	HVD233, HVD234, HVD235	-40	125	°C

(1) Maximum free-air temperature operation is allowed as long as the device maximum junction temperature is not exceeded.

8.4 Thermal Information

over operating free-air temperature range (unless otherwise noted)

PARAMETERS		TEST CONDITIONS	VALUE	UNIT
$R_{\theta JA}$	Junction-to-ambient thermal resistance ⁽¹⁾	Low-K ⁽²⁾ board, no air flow	185	°C/W
		High-K ⁽³⁾ board, no air flow	101	
$R_{\theta JB}$	Junction-to-board thermal resistance	High-K ⁽³⁾ board, no air flow	82.8	°C/W
$R_{\theta JC}$	Junction-to-case thermal resistance		26.5	°C/W
$P_{(AVG)}$	Average power dissipation	$R_L = 60 \Omega$, R_S at 0 V, input to D a 1-MHz 50% duty cycle square wave V_{CC} at 3.3 V, $T_A = 25^\circ\text{C}$	36.4	mW
$T_{(SD)}$	Thermal shutdown junction temperature		170	°C

(1) See [SZZA003](#) for an explanation of this parameter.

(2) JESD51-3 low effective thermal conductivity test board for leaded surface mount packages.

(3) JESD51-7 high effective thermal conductivity test board for leaded surface mount packages.

8.5 Power Dissipation Ratings

PACKAGE	CIRCUIT BOARD	$T_A \leq 25^\circ\text{C}$ POWER RATING	DERATING FACTOR ⁽¹⁾ ABOVE $T_A = 25^\circ\text{C}$	$T_A = 85^\circ\text{C}$ POWER RATING	$T_A = 125^\circ\text{C}$ POWER RATING
D	Low-K	596.6 mW	5.7 mW/°C	255.7 mW	28.4 mW
D	High-K	1076.9 mW	10.3 mW/°C	461.5 mW	51.3 mW

(1) This is the inverse of the junction-to-ambient thermal resistance when board-mounted and with no air flow.

8.6 Electrical Characteristics: Driver

over operating free-air temperature range (unless otherwise noted)

PARAMETER		TEST CONDITIONS		MIN	TYP ⁽¹⁾	MAX	UNIT
V _{O(D)}	Bus output voltage (Dominant)	CANH	D at 0 V, R _S at 0 V, See Figure 12 and Figure 13	2.45		V _{CC}	V
		CANL		0.5		1.25	
V _O	Bus output voltage (Recessive)	CANH	D at 3 V, R _S at 0 V, See Figure 12 and Figure 13		2.3		V
		CANL			2.3		
V _{OD(D)}	Differential output voltage (Dominant)		D at 0 V, R _S at 0 V, See Figure 12 and Figure 13	1.5	2	3	V
			D at 0 V, R _S at 0 V, See Figure 13 and Figure 14	1.2	2	3	
V _{OD}	Differential output voltage (Recessive)		D at 3 V, R _S at 0 V, See Figure 12 and Figure 13	-120		12	mV
			D at 3 V, R _S at 0 V, No Load	-0.5		0.05	
V _{OC(pp)}	Peak-to-peak common-mode output voltage		See Figure 21		1		V
I _{IH}	High-level input current	D, EN, LBK, AB	D = 2 V or EN = 2 V or LBK = 2 V or AB = 2 V	-30		30	μA
I _{IL}	Low-level input current	D, EN, LBK, AB	D = 0.8 V or EN = 0.8 V or LBK = 0.8 V or AB = 0.8 V	-30		30	μA
I _{OS}	Short-circuit output current		V _{CANH} = -7 V, CANL Open, See Figure 26	-250			mA
			V _{CANH} = 12 V, CANL Open, See Figure 26			1	
			V _{CANL} = -7 V, CANH Open, See Figure 26	-1			
			V _{CANL} = 12 V, CANH Open, See Figure 26			250	
C _O	Output capacitance		See receiver input capacitance				
I _{IRS(s)}	R _S input current for standby		R _S at 0.75 V _{CC}	-10			μA
I _{CC}	Supply current	Sleep	EN at 0 V, D at V _{CC} , R _S at 0 V or V _{CC}		0.05	2	μA
		Standby	R _S at V _{CC} , D at V _{CC} , AB at 0 V, LBK at 0 V, EN at V _{CC}		200	600	
		Dominant	D at 0 V, No Load, AB at 0 V, LBK at 0 V, R _S at 0 V, EN at V _{CC}			6	mA
		Recessive	D at V _{CC} , No Load, AB at 0 V, LBK at 0 V, R _S at 0 V, EN at V _{CC}			6	

(1) All typical values are at 25°C and with a 3.3-V supply.

8.7 Electrical Characteristics: Receiver

over operating free-air temperature range (unless otherwise noted)

PARAMETER		TEST CONDITIONS	MIN	TYP ⁽¹⁾	MAX	UNIT	
V_{IT+}	Positive-going input threshold voltage	AB at 0 V, LBK at 0 V, EN at V_{CC} , See Table 1		750	900	mV	
V_{IT-}	Negative-going input threshold voltage		500	650			
V_{hys}	Hysteresis voltage ($V_{IT+} - V_{IT-}$)		100				
V_{OH}	High-level output voltage	$I_O = -4$ mA, See Figure 17	2.4			V	
V_{OL}	Low-level output voltage	$I_O = 4$ mA, See Figure 17		0.4			
I_i	Bus input current	CANH or CANL at 12 V		150	500	μ A	
		CANH or CANL at 12 V, V_{CC} at 0 V	Other bus pin at 0 V, D at 3 V, AB at 0 V, LBK at 0 V, R_S at 0 V, EN at V_{CC}	200	600		
		CANH or CANL at -7 V		-610	-150		
		CANH or CANL at -7 V, V_{CC} at 0 V		-450	-130		
C_i	Input capacitance (CANH or CANL)	Pin-to-ground, $V_i = 0.4 \sin(4E6\pi t) + 0.5$ V, D at 3 V, AB at 0 V, LBK at 0 V, EN at V_{CC}			40		pF
C_{iD}	Differential input capacitance	Pin-to-pin, $V_i = 0.4 \sin(4E6\pi t) + 0.5$ V, D at 3 V, AB at 0 V, LBK at 0 V, EN at V_{CC}		20			
R_{iD}	Differential input resistance	D at 3 V, AB at 0 V, LBK at 0 V, EN at V_{CC}	40		100	k Ω	
R_{iN}	Input resistance (CANH or CANL) to ground		20		50		
I_{CC}	Supply current	Sleep	EN at 0 V, D at V_{CC} , R_S at 0 V or V_{CC}		0.05	2	μ A
		Standby	R_S at V_{CC} , D at V_{CC} , AB at 0 V, LBK at 0 V, EN at V_{CC}		200	600	
		Dominant	D at 0 V, No Load, R_S at 0 V, LBK at 0 V, AB at 0 V, EN at V_{CC}			6	mA
		Recessive	D at V_{CC} , No Load, R_S at 0 V, LBK at 0 V, AB at 0 V, EN at V_{CC}			6	

(1) All typical values are at 25°C and with a 3.3-V supply.

8.8 Switching Characteristics: Driver

over operating free-air temperature range (unless otherwise noted)

PARAMETER		TEST CONDITIONS	MIN	TYP ⁽¹⁾	MAX	UNIT
t_{PLH}	Propagation delay time, low-to-high-level output	R_S at 0 V, See Figure 15		35	85	ns
		R_S with 10 k Ω to ground, See Figure 15		70	125	
		R_S with 100 k Ω to ground, See Figure 15		500	870	
t_{PHL}	Propagation delay time, high-to-low-level output	R_S at 0 V, See Figure 15		70	120	ns
		R_S with 10 k Ω to ground, See Figure 15		130	180	
		R_S with 100 k Ω to ground, See Figure 15		870	1200	
$t_{sk(p)}$	Pulse skew ($ t_{PHL} - t_{PLH} $)	R_S at 0 V, See Figure 15		35		ns
		R_S with 10 k Ω to ground, See Figure 15		60		
		R_S with 100 k Ω to ground, See Figure 15		370		
t_r	Differential output signal rise time	R_S at 0 V, See Figure 15	20		70	ns
t_f	Differential output signal fall time		20		70	
t_r	Differential output signal rise time	R_S with 10 k Ω to ground, See Figure 15	30		135	ns
t_f	Differential output signal fall time		30		135	
t_r	Differential output signal rise time	R_S with 100 k Ω to ground, See Figure 15	350		1400	ns
t_f	Differential output signal fall time		350		1400	
$t_{en(s)}$	Enable time from standby to dominant	See Figure 19 and Figure 20		0.6	1.5	μ s
$t_{en(z)}$	Enable time from sleep to dominant			1	5	

(1) All typical values are at 25°C and with a 3.3-V supply.

8.9 Switching Characteristics: Receiver

over operating free-air temperature range (unless otherwise noted)

PARAMETER		TEST CONDITIONS	MIN	TYP ⁽¹⁾	MAX	UNIT
t_{PLH}	Propagation delay time, low-to-high-level output	See Figure 17		35	60	ns
t_{PHL}	Propagation delay time, high-to-low-level output			35	60	
$t_{sk(p)}$	Pulse skew ($ t_{PHL} - t_{PLH} $)			7		
t_r	Output signal rise time			2	5	
t_f	Output signal fall time			2	5	

(1) All typical values are at 25°C and with a 3.3-V supply.

8.10 Switching Characteristics: Device

over operating free-air temperature range (unless otherwise noted)

PARAMETER		TEST CONDITIONS	MIN	TYP ⁽¹⁾	MAX	UNIT
$t_{(LBK)}$	Loopback delay, driver input to receiver output	HVD233 See Figure 23		7.5	12	ns
$t_{(AB1)}$	Loopback delay, driver input to receiver output	HVD235 See Figure 24		10	20	ns
$t_{(AB2)}$	Loopback delay, bus input to receiver output		See Figure 25		35	60
$t_{(loop1)}$	Total loop delay, driver input to receiver output, recessive to dominant	R_S at 0 V, See Figure 22		70	135	ns
		R_S with 10 k Ω to ground, See Figure 22		105	190	
		R_S with 100 k Ω to ground, See Figure 22		535	1000	
$t_{(loop2)}$	Total loop delay, driver input to receiver output, dominant to recessive	R_S at 0 V, See Figure 22		70	135	ns
		R_S with 10 k Ω to ground, See Figure 22		105	190	
		R_S with 100 k Ω to ground, See Figure 22		535	1000	

(1) All typical values are at 25°C and with a 3.3-V supply.

8.11 Typical Characteristics

$R_s, LBK, AB = 0\text{ V}; EN = V_{CC}$

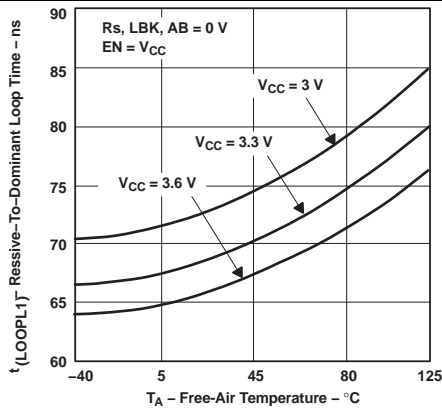

Figure 1. Rcessive-to-Dominant Loop Time vs Free-Air Temperature

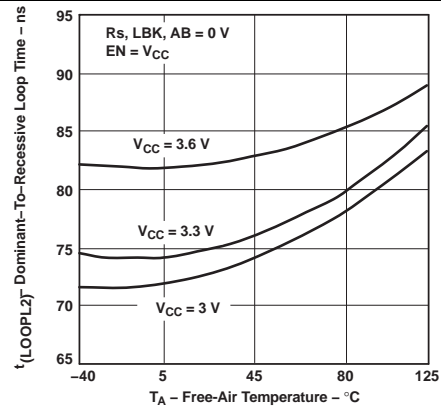

Figure 2. Dominant-to-Recessive Loop Time vs Free-Air Temperature

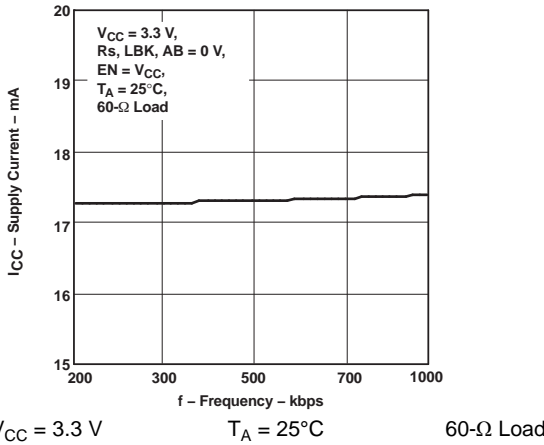

Figure 3. Supply Current vs Frequency

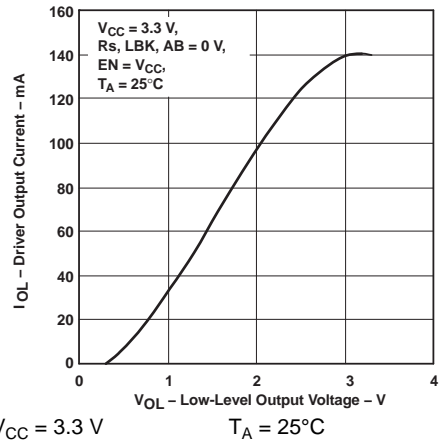

Figure 4. Driver Low-Level Output Current vs Low-Level Output Voltage

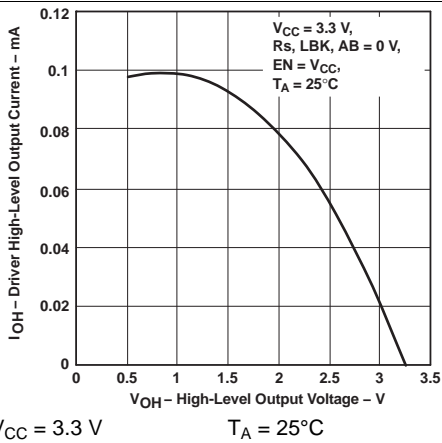

Figure 5. Driver High-Level Output Current vs High-Level Output Voltage

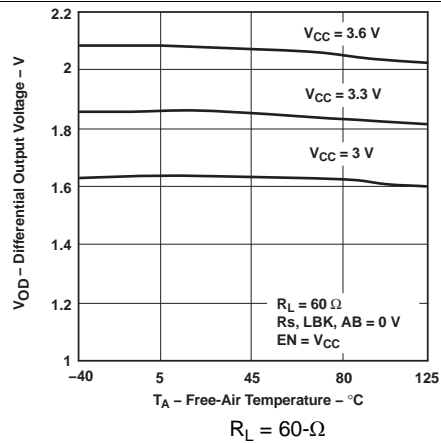
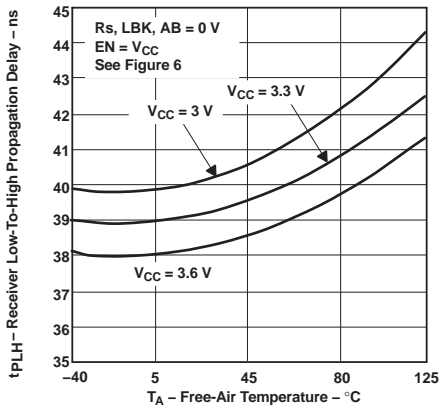

Figure 6. Differential Output Voltage vs Free-Air Temperature

Typical Characteristics (continued)

$R_s, LBK, AB = 0\text{ V}; EN = V_{CC}$



See Figure 3

Figure 7. Receiver Low-to-High Propagation Delay vs Free-Air Temperature

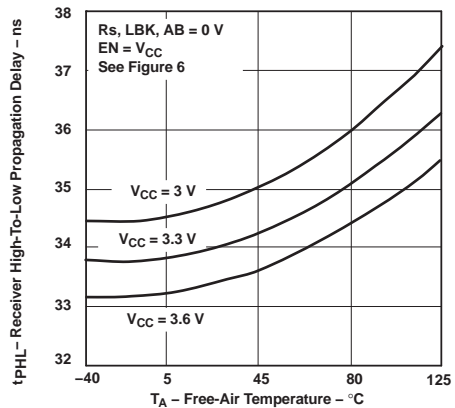

See Figure 3

Figure 8. Receiver High-to-Low Propagation Delay vs Free-Air Temperature

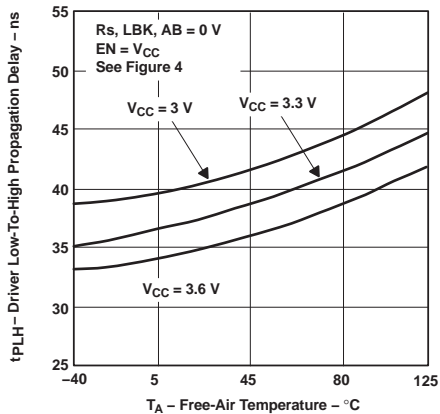

See Figure 1

Figure 9. Driver Low-to-High Propagation Delay vs Free-Air Temperature

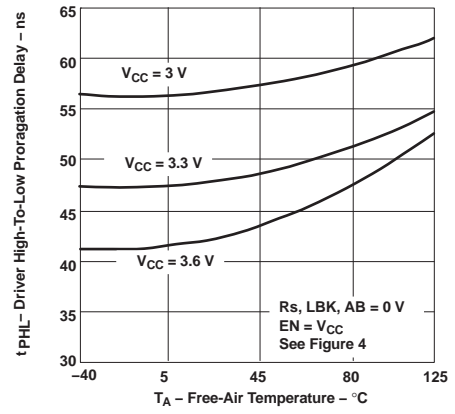

See Figure 1

Figure 10. Driver High-to-Low Propagation Delay vs Free-Air Temperature

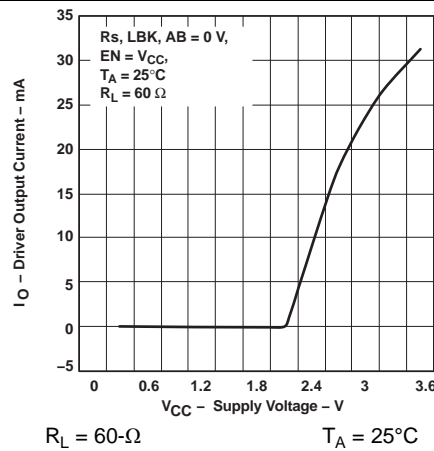

Figure 11. Driver Output Current vs Supply Voltage

9 Parameter Measurement Information

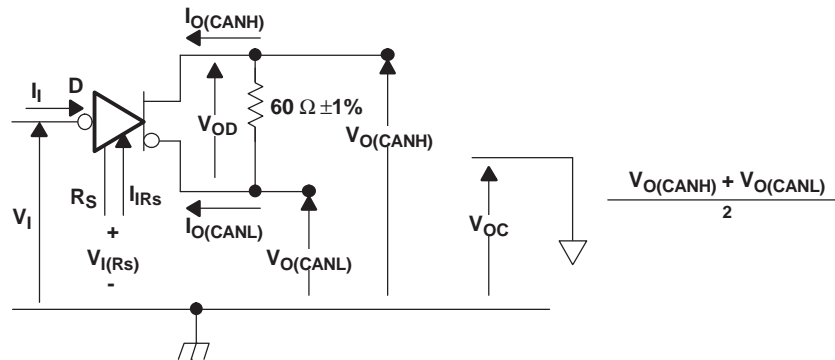

Figure 12. Driver Voltage, Current, and Test Definition

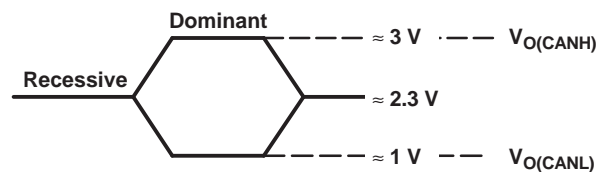

Figure 13. Bus Logic State Voltage Definitions

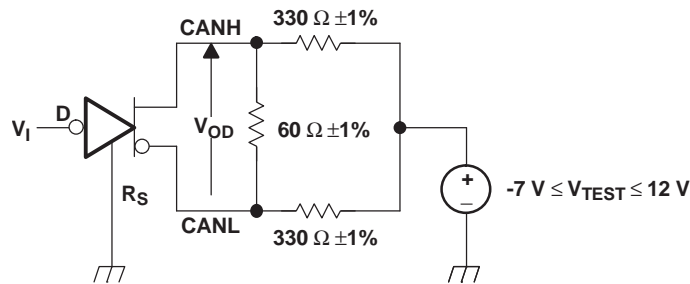
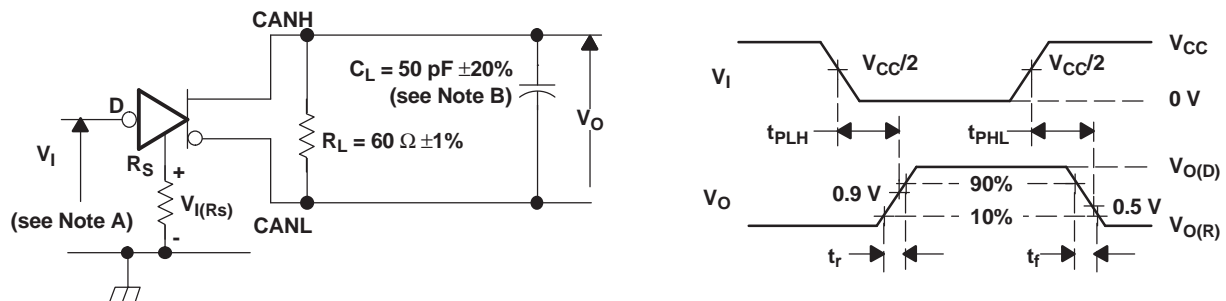

Figure 14. Driver V_{OD}



- A. The input pulse is supplied by a generator having the following characteristics: Pulse repetition rate (PRR) \leq 125 kHz, 50% duty cycle, $t_r \leq$ 6 ns, $t_f \leq$ 6 ns, $Z_O =$ 50 Ω .
- B. C_L includes fixture and instrumentation capacitance.

Figure 15. Driver Test Circuit and Voltage Waveforms

Parameter Measurement Information (continued)

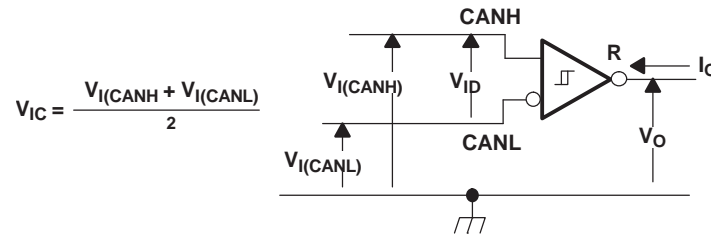
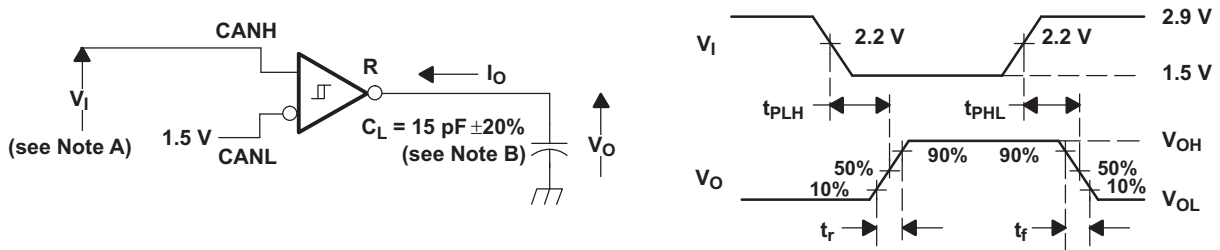

Figure 16. Receiver Voltage and Current Definitions



- A. The input pulse is supplied by a generator having the following characteristics: Pulse repetition rate (PRR) ≤ 125 kHz, 50% duty cycle, $t_r \leq 6$ ns, $t_f \leq 6$ ns, $Z_0 = 50 \Omega$.
- B. C_L includes fixture and instrumentation capacitance.

Figure 17. Receiver Test Circuit and Voltage Waveforms

Table 1. Differential Input Voltage Threshold Test

INPUT		OUTPUT	MEASURED
V_{CANH}	V_{CANL}	R	$ V_{ID} $
-6.1 V	-7 V	L	V_{OL}
12 V	11.1 V	L	
-1 V	-7 V	L	
12 V	6 V	L	
-6.5 V	-7 V	H	V_{OH}
12 V	11.5 V	H	
-7 V	-1 V	H	
6 V	12 V	H	
Open	Open	H	

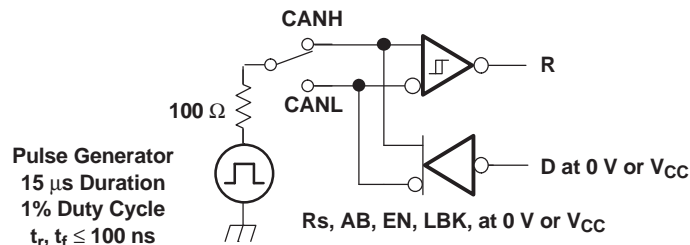

NOTE: This test is conducted to test survivability only. Data stability at the R output is not specified.

Figure 18. Test Circuit, Transient Overvoltage Test

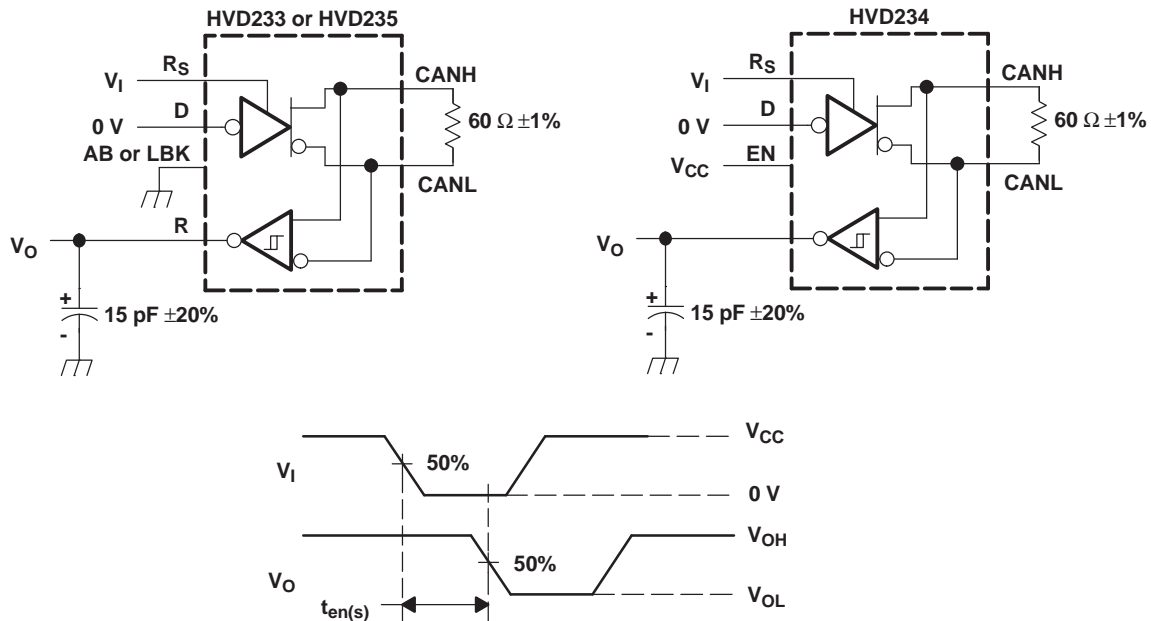

NOTE: All V_I input pulses are supplied by a generator having the following characteristics: t_r or $t_f \leq 6$ ns, pulse repetition rate (PRR) = 125 kHz, 50% duty cycle.

Figure 19. $T_{en(s)}$ Test Circuit and Voltage Waveforms

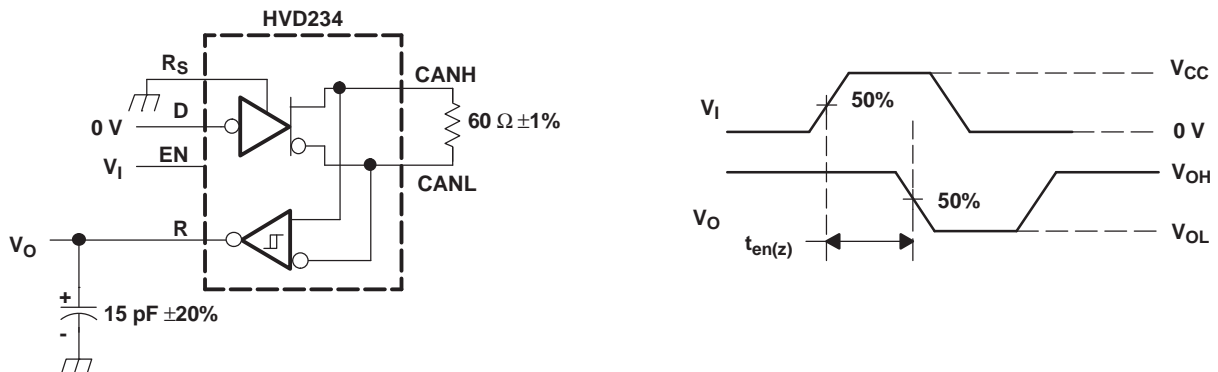

NOTE: All V_I input pulses are supplied by a generator having the following characteristics: t_r or $t_f \leq 6$ ns, pulse repetition rate (PRR) = 50 kHz, 50% duty cycle.

Figure 20. $T_{en(z)}$ Test Circuit and Voltage Waveforms

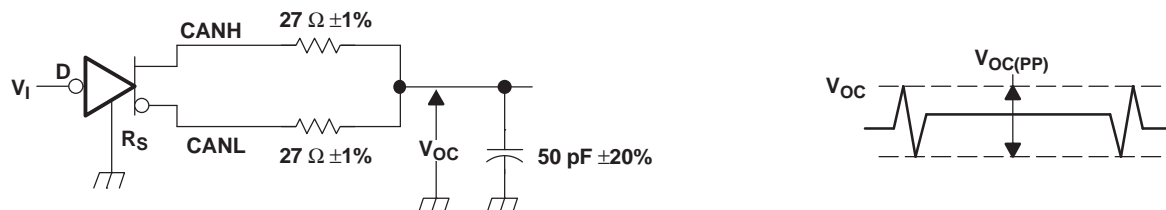

NOTE: All V_I input pulses are supplied by a generator having the following characteristics: t_r or $t_f \leq 6$ ns, pulse repetition rate (PRR) = 125 kHz, 50% duty cycle.

Figure 21. $V_{OC(pp)}$ Test Circuit and Voltage Waveforms

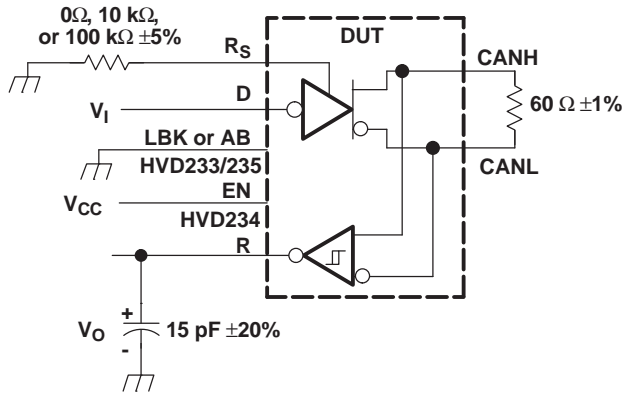

NOTE: All V_i input pulses are supplied by a generator having the following characteristics:
 t_r or $t_f \leq 6$ ns, pulse repetition rate (PRR) = 125 kHz, 50% duty cycle.

Figure 22. $T_{(loop)}$ Test Circuit and Voltage Waveforms

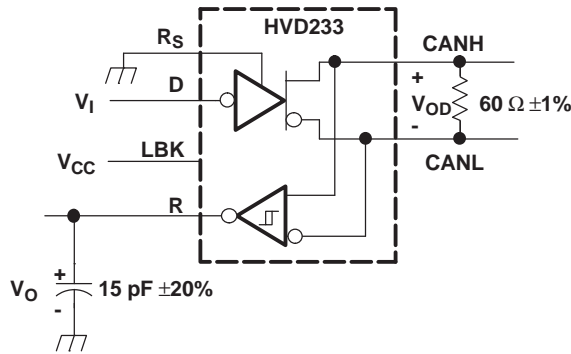

NOTE: All V_i input pulses are supplied by a generator having the following characteristics:
 t_r or $t_f \leq 6$ ns, pulse repetition rate (PRR) = 125 kHz, 50% duty cycle.

Figure 23. $T_{(LBK)}$ Test Circuit and Voltage Waveforms

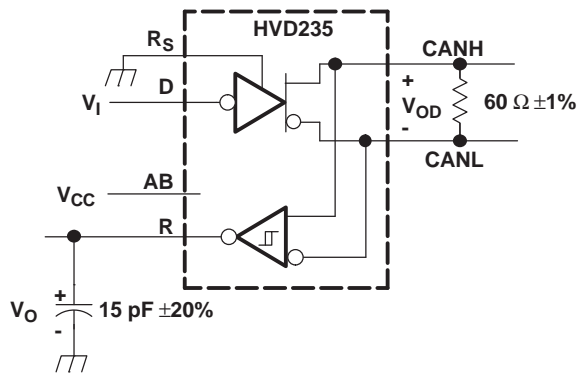

NOTE: All V_i input pulses are supplied by a generator having the following characteristics:
 t_r or $t_f \leq 6$ ns, pulse repetition rate (PRR) = 125 kHz, 50% duty cycle.

Figure 24. $T_{(AB1)}$ Test Circuit and Voltage Waveforms

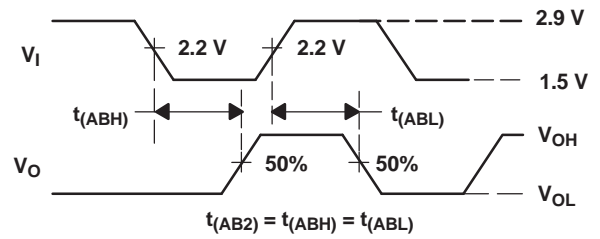
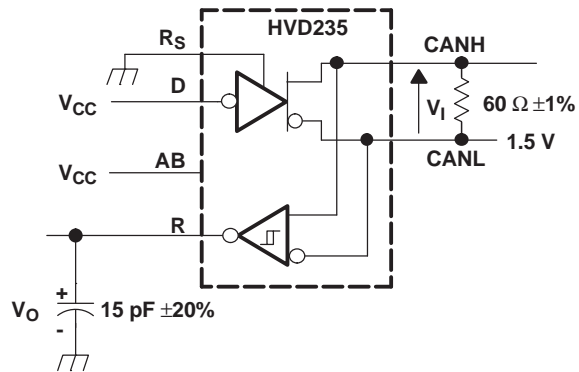

NOTE: All V_I input pulses are supplied by a generator having the following characteristics:
 t_r or $t_f \leq 6$ ns, pulse repetition rate (PRR) = 125 kHz, 50% duty cycle.

Figure 25. $T_{(AB2)}$ Test Circuit and Voltage Waveforms

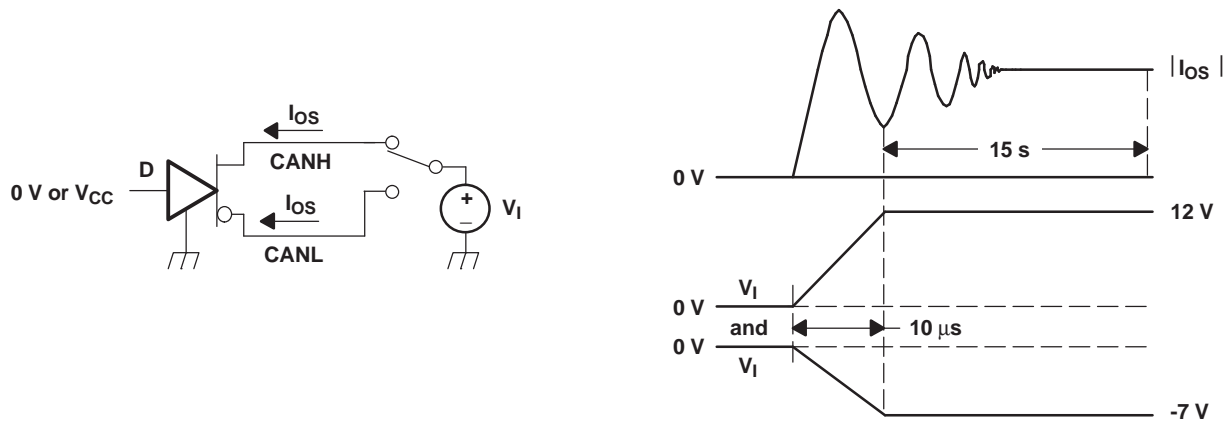
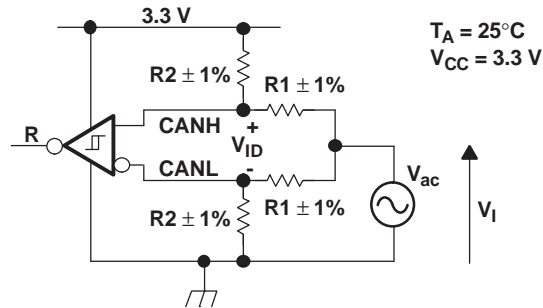

Figure 26. I_{OS} Test Circuit and Waveforms



The R Output State Does Not Change During Application of the Input Waveform.

V_{ID}	R1	R2
500 mV	50 Ω	280 Ω
900 mV	50 Ω	130 Ω



NOTE: All input pulses are supplied by a generator with $f \leq 1.5$ MHz.

Figure 27. Common-Mode Voltage Rejection

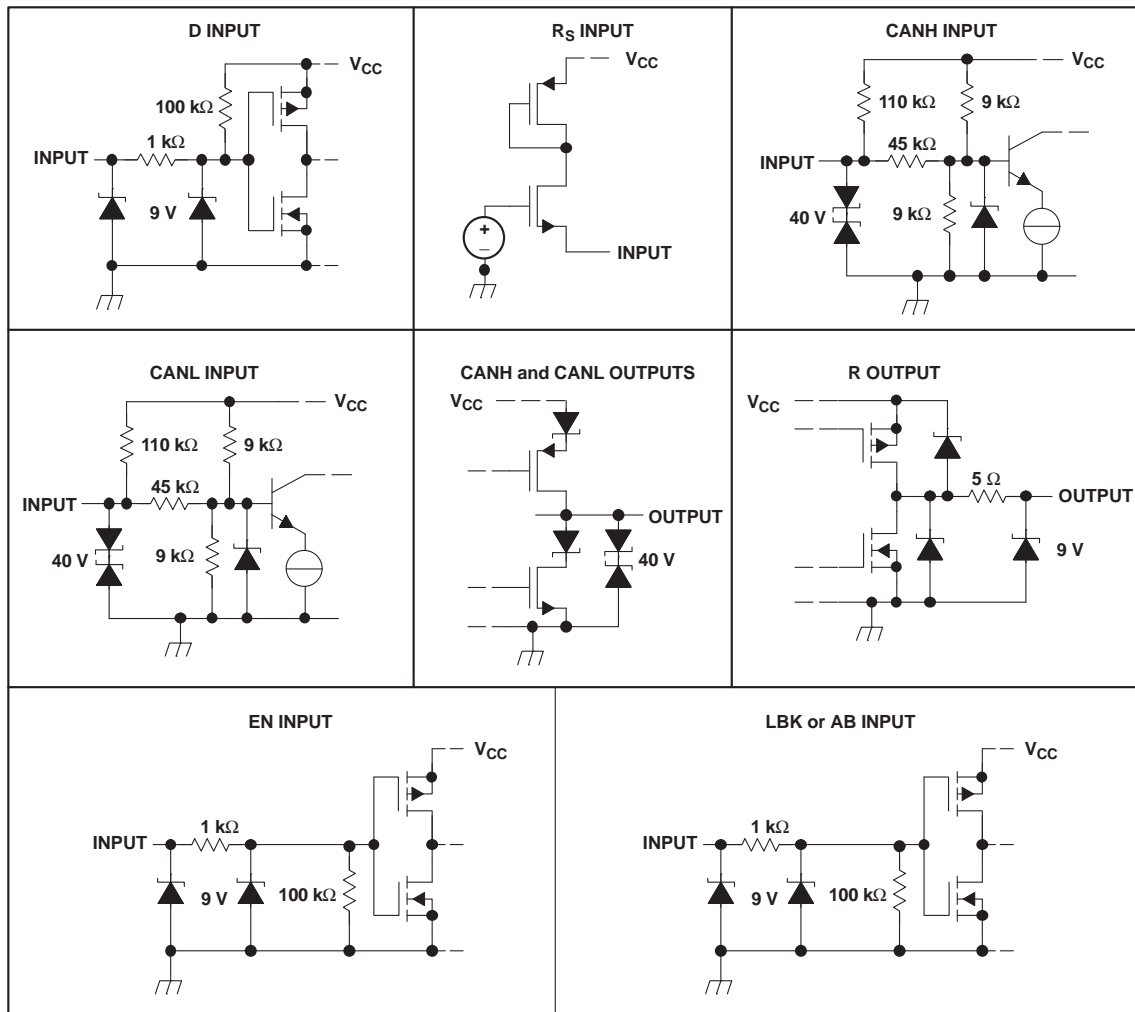

Figure 28. Equivalent Input and Output Schematic Diagrams

10 Detailed Description

10.1 Overview

This family of CAN transceivers is compatible with the ISO11898-2 High-Speed CAN (controller area network) physical layer standard. They are designed to interface between the differential bus lines in CAN and the CAN protocol controller at data rates up to 1 Mbps.

10.2 Functional Block Diagrams

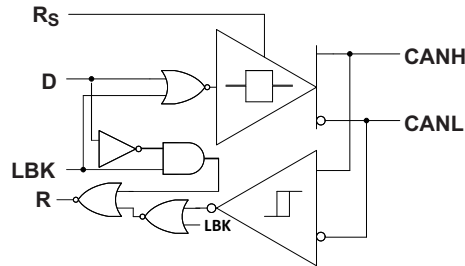

Figure 29. SN65HVD33 Functional Block Diagram

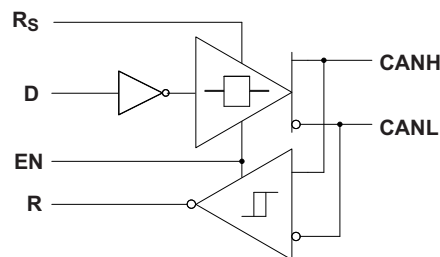

Figure 30. SN65HVD34 Functional Block Diagram

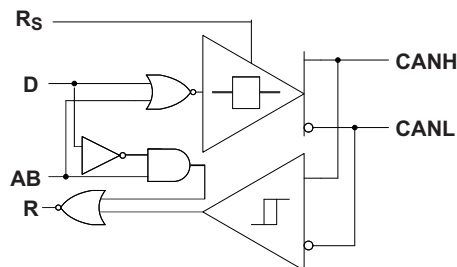

Figure 31. SN65HVD35 Functional Block Diagram

10.3 Feature Description

10.3.1 Diagnostic Loopback (SN65HVD233)

The diagnostic loopback or internal loopback function of the SN65HVD233 is enabled with a high-level input on pin 5, LBK. This mode disables the driver output while keeping the bus pins biased to the recessive state. This mode also redirects the D data input (transmit data) through logic to the received data output pin), thus creating an internal loopback of the transmit to receive data path. This mimics the loopback that occurs normally with a CAN transceiver because the receiver loops back the driven output to the R (receive data) pin. This mode allows the host protocol controller to input and read back a bit sequence or CAN messages to perform diagnostic routines without disturbing the CAN bus. A typical CAN bus application is displayed in [Figure 36](#).

Feature Description (continued)

If the LBK pin is not used it may be tied to ground (GND). However, it is pulled low internally (defaults to a low-level input) and may be left open if not in use.

10.3.2 Autobaud Loopback (SN65HVD235)

The autobaud loopback mode of the SN65HVD235 is enabled by placing a high level input on pin 5, AB. In autobaud mode, the driver output is disabled, thus blocking the D pin to bus path and the bus transmit function of the transceiver. The bus pins remain biased to recessive. The receiver to R pin path or the bus receive function of the device remains operational, allowing bus activity to be monitored. In addition, the autobaud mode adds an internal logic loopback path from the D pin to R pin so the local node may transmit to itself in sync with bus traffic while not disturbing messages on the bus. Thus if the local node's CAN controller generates an error frame, it is not transmitted to the bus, but is detected only by the local CAN controller. This is especially helpful to determine if the local node is set to the same baud rate as the network, and if not adjust it to the network baud rate (autobaud detection).

Autobaud detection is best suited to applications that have a known selection of baud rates. For example, a popular industrial application has optional settings of 125 kbps, 250 kbps, or 500 kbps. Once the SN65HVD235 is placed into autobaud loopback mode the application software could assume the first baud rate of 125 kbps. It then waits for a message to be transmitted by another node on the bus. If the wrong baud rate has been selected, an error message is generated by the local CAN controller because the sample times will not be at the correct time. However, because the bus-transmit function of the device has been disabled, no other nodes receive the error frame generated by this node's local CAN controller.

The application would then make use of the status register indications of the local CAN controller for message received and error warning status to determine if the set baud rate is correct or not. The warning status indicates that the CAN controller error counters have been incremented. A message received status indicates that a good message has been received. If an error is generated, the application would then set the CAN controller with the next possibly valid baud rate, and wait to receive another message. This pattern is repeated until an error free message has been received, thus the correct baud rate has been selected. At this point the application would place the SN65HVD235 in a normal transmitting mode by setting pin 5 to a low-level, thus enabling bus-transmit and bus-receive functions to normal operating states for the transceiver.

If the AB pin is not used it may be tied to ground (GND). However, it is pulled low internally (defaults to a low-level input) and may be left open if not in use.

10.3.3 Slope Control

The rise and fall slope of the SN65HVD233, SN65HVD234, and SN65HVD235 driver output can be adjusted by connecting a resistor from the Rs (pin 8) to ground (GND), or to a low-level input voltage as shown in [Figure 32](#).

The slope of the driver output signal is proportional to the pin's output current. This slope control is implemented with an external resistor value of 10 k Ω to achieve a ~ 15 V/ μ s slew rate, and up to 100 k Ω to achieve a ~ 2.0 V/ μ s slew rate. A typical slew rate versus pull-down resistance graph is shown in [Figure 33](#). Typical driver output waveforms with slope control are displayed in [Figure 39](#).

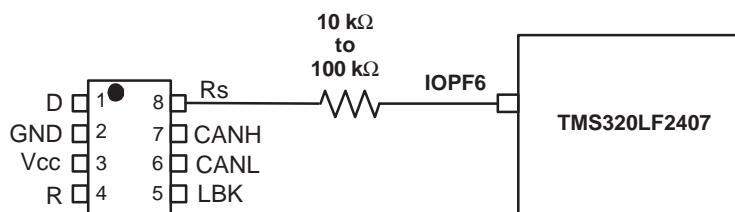

Figure 32. Slope Control/Standby Connection to a DSP

Feature Description (continued)

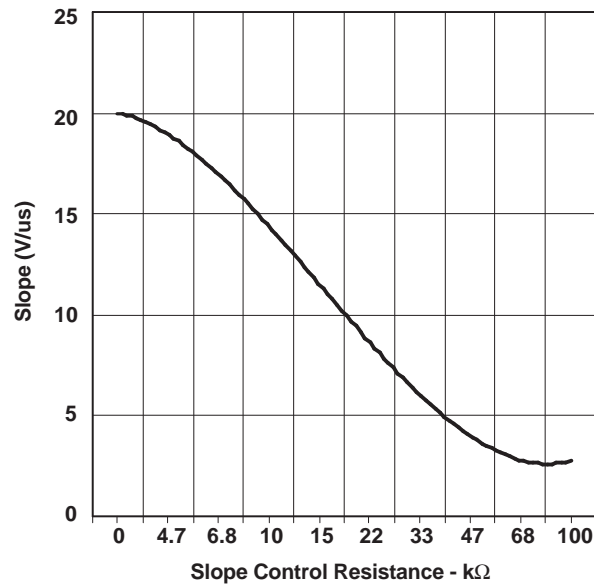

Figure 33. HVD233 Driver Output Signal Slope vs Slope Control Resistance Value

10.3.4 Standby

If a high-level input ($> 0.75 V_{CC}$) is applied to R_S (pin 8), the circuit enters a low-current, *listen only* standby mode during which the driver is switched off and the receiver remains active. If using this mode to save system power while waiting for bus traffic, the local controller can monitor the R output pin for a falling edge which indicates that a dominant signal was driven onto the CAN bus. The local controller can then drive the R_S pin low to return to slope control mode or high-speed mode.

10.3.5 Thermal Shutdown

If the junction temperature of the device exceeds the thermal shut down threshold the device turns off the CAN driver circuits thus blocking the D pin to bus transmission path. The shutdown condition is cleared when the junction temperature drops below the thermal shutdown temperature of the device. The CAN bus pins are high impedance biased to recessive level during a thermal shutdown, and the receiver to R pin path remains operational.

10.4 Device Functional Modes

10.4.1 Driver and Receiver

Table 2. Driver (SN65HVD233 or SN65HVD235)

INPUTS			OUTPUTS		
D	LBK/AB	R_S	CANH	CANL	BUS STATE
X	X	$> 0.75 V_{CC}$	Z	Z	Recessive
L	L or open	$\leq 0.33 V_{CC}$	H	L	Dominant
H or open	X		Z	Z	Recessive
X	H	$\leq 0.33 V_{CC}$	Z	Z	Recessive

Table 3. Receiver (SN65HVD233)

INPUTS				OUTPUT
BUS STATE	$V_{ID} = V_{(CANH)} - V_{(CANL)}$	LBK	D	R
Dominant	$V_{ID} \geq 0.9\text{ V}$	L or open	X	L
Recessive	$V_{ID} \leq 0.5\text{ V}$ or open	L or open	H or open	H
?	$0.5\text{ V} < V_{ID} < 0.9\text{ V}$	L or open	H or open	?
X	X	H	L	L
X	X		H	H

Table 4. Receiver (SN65HVD235)⁽¹⁾

INPUTS				OUTPUT
BUS STATE	$V_{ID} = V_{(CANH)} - V_{(CANL)}$	AB	D	R
Dominant	$V_{ID} \geq 0.9\text{ V}$	L or open	X	L
Recessive	$V_{ID} \leq 0.5\text{ V}$ or open	L or open	H or open	H
?	$0.5\text{ V} < V_{ID} < 0.9\text{ V}$	L or open	H or open	?
Dominant	$V_{ID} \geq 0.9\text{ V}$	H	X	L
Recessive	$V_{ID} \leq 0.5\text{ V}$ or open	H	H	H
Recessive	$V_{ID} \leq 0.5\text{ V}$ or open	H	L	L
?	$0.5\text{ V} < V_{ID} < 0.9\text{ V}$	H	L	L

(1) H = high level; L = low level; Z = high impedance; X = irrelevant; ? = indeterminate

Table 5. Driver (SN65HVD234)

INPUTS			OUTPUTS		
D	EN	R_s	CANH	CANL	BUS STATE
L	H	$\leq 0.33\text{ V}_{CC}$	H	L	Dominant
H	X	$\leq 0.33\text{ V}_{CC}$	Z	Z	Recessive
Open	X	X	Z	Z	Recessive
X	X	$> 0.75\text{ V}_{CC}$	Z	Z	Recessive
X	L or open	X	Z	Z	Recessive

Table 6. Receiver (SN65HVD234)⁽¹⁾

INPUTS			OUTPUT
BUS STATE	$V_{ID} = V_{(CANH)} - V_{(CANL)}$	EN	R
Dominant	$V_{ID} \geq 0.9\text{ V}$	H	L
Recessive	$V_{ID} \leq 0.5\text{ V}$ or open	H	H
?	$0.5\text{ V} < V_{ID} < 0.9\text{ V}$	H	?
X	X	L or open	H

(1) H = high level; L = low level; Z = high impedance; X = irrelevant; ? = indeterminate

11 Application and Implementation

NOTE

Information in the following applications sections is not part of the TI component specification, and TI does not warrant its accuracy or completeness. TI's customers are responsible for determining suitability of components for their purposes. Customers should validate and test their design implementation to confirm system functionality.

11.1 Application Information

The CAN bus has two states during powered operation of the device; *dominant* and *recessive*. A dominant bus state is when the bus is driven differentially, corresponding to a logic low on the D and R pin. A recessive bus state is when the bus is biased to $V_{CC} / 2$ via the high-resistance internal resistors R_{IN} and R_{ID} of the receiver, corresponding to a logic high on the D and R pins. See [Figure 34](#) and [Figure 35](#).

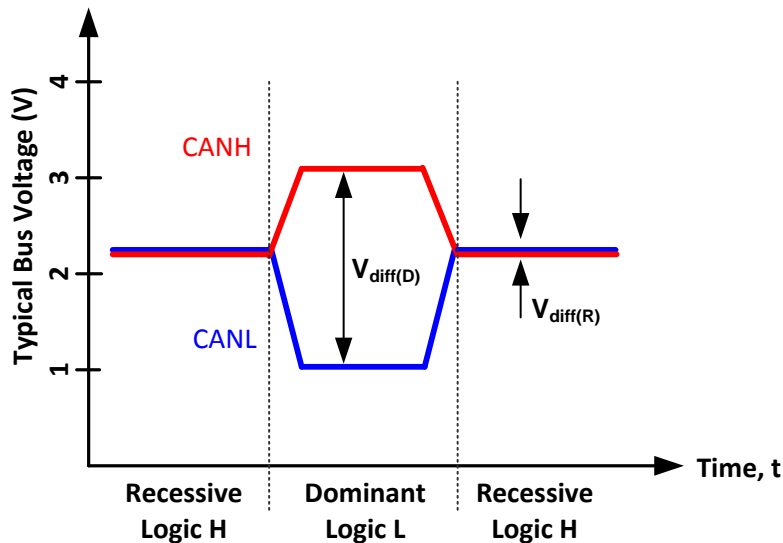

Figure 34. Bus States (Physical Bit Representation)

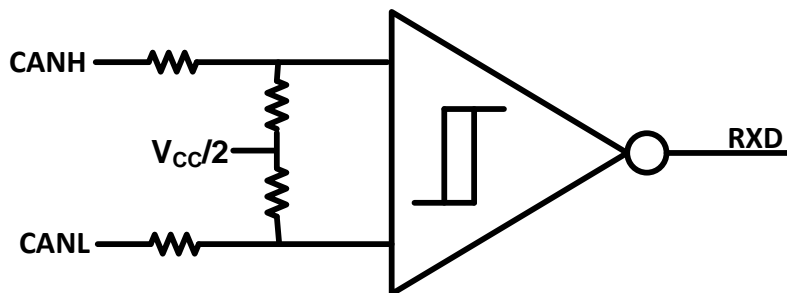

Figure 35. Simplified Recessive Common Mode Bias and Receiver

These CAN transceivers are typically used in applications with a host microprocessor or FPGA that includes the link layer portion of the CAN protocol. The different nodes on the network are typically connected through the use of a 120- Ω characteristic impedance twisted-pair cable with termination on both ends of the bus.

11.2 Typical Application

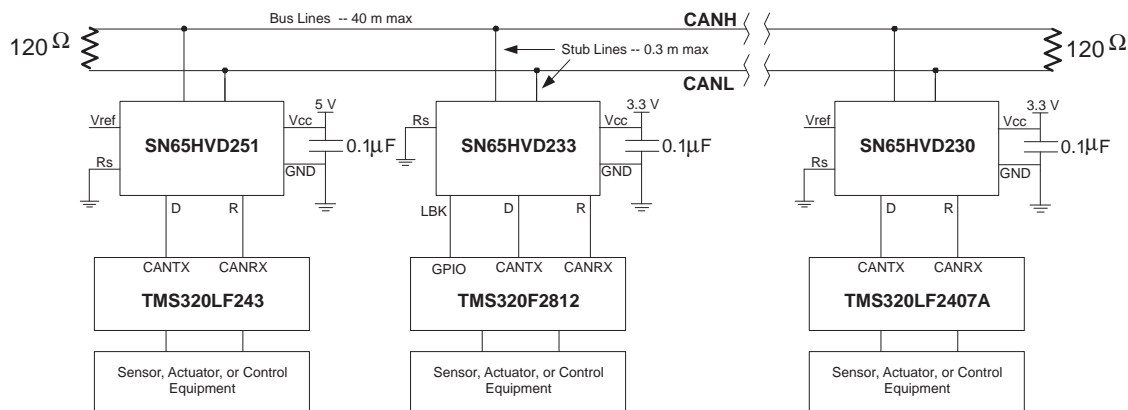

Figure 36. Typical HVD233 Application

11.2.1 Design Requirements

11.2.1.1 Bus Loading, Length and Number of Nodes

The ISO 11898 Standard specifies up to a data rate of 1 Mbps, maximum CAN bus cable length of 40 m, maximum drop line (stub) length of 0.3 m and a maximum of 30 nodes. However, with careful network design, the system may have longer cables, longer stub lengths, and many more nodes to a bus. Many CAN organizations and standards have scaled the use of CAN for applications outside the original ISO 11898 standard. They have made system level trade-offs for data rate, cable length, and parasitic loading of the bus. Examples of some of these specifications are ARINC825, CANopen, CAN Kingdom, DeviceNet and NMEA200.

A high number of nodes requires a transceiver with high input impedance and wide common mode range such as the SN65HVD23x CAN family. ISO 11898-2 specifies the driver differential output with a 60- Ω load (two 120- Ω termination resistors in parallel) and the differential output must be greater than 1.5 V. The SN65HVD23x devices are specified to meet the 1.5-V requirement with a 60- Ω load, and additionally specified with a differential output voltage minimum of 1.2 V across a common mode range of -2 V to 7 V through a 330- Ω coupling network. This network represents the bus loading of 120 SN65HVD23x transceivers based on their minimum differential input resistance of 40 k Ω . Therefore, the SN65HVD23x supports up to 120 transceivers on a single bus segment with margin to the 1.2-V minimum differential input voltage requirement at each node.

For CAN network design, margin must be given for signal loss across the system and cabling, parasitic loadings, network imbalances, ground offsets and signal integrity thus a practical maximum number of nodes may be lower. Bus length may also be extended beyond the original ISO 11898 standard of 40 m by careful system design and data rate tradeoffs. For example, CANopen network design guidelines allow the network to be up to 1 km with changes in the termination resistance, cabling, less than 64 nodes and significantly lowered data rate.

This flexibility in CAN network design is one of the key strengths of the various extensions and additional standards that have been built on the original ISO 11898 CAN standard.

11.2.1.2 CAN Termination

The ISO 11898 standard specifies the interconnect to be a twisted-pair cable (shielded or unshielded) with 120- Ω characteristic impedance (Z_0). Resistors equal to the characteristic impedance of the line should be used to terminate both ends of the cable to prevent signal reflections. Unterminated drop lines (stubs) connecting nodes to the bus should be kept as short as possible to minimize signal reflections. The termination may be on the cable or in a node, but if nodes may be removed from the bus the termination must be carefully placed so that it is not removed from the bus.

Typical Application (continued)

11.2.2 Detailed Design Procedure

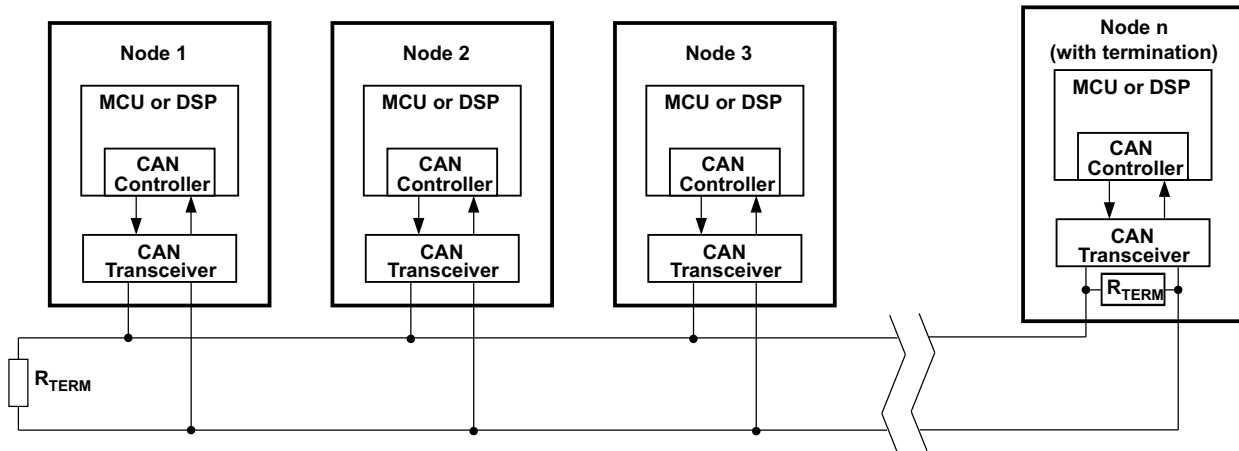

Figure 37. Typical CAN Bus

Termination is typically a 120-Ω resistor at each end of the bus. If filtering and stabilization of the common mode voltage of the bus is desired, then split termination may be used (see Figure 38). Split termination uses two 60-Ω resistors with a capacitor in the middle of these resistors to ground. Split termination improves the electromagnetic emissions behavior of the network by eliminating fluctuations in the bus common mode voltages at the start and end of message transmissions.

Care should be taken in the power ratings of the termination resistors used. Typically the worst case condition would be if the system power supply was shorted across the termination resistance to ground. In most cases the current flow through the resistor in this condition would be much higher than the transceiver's current limit.

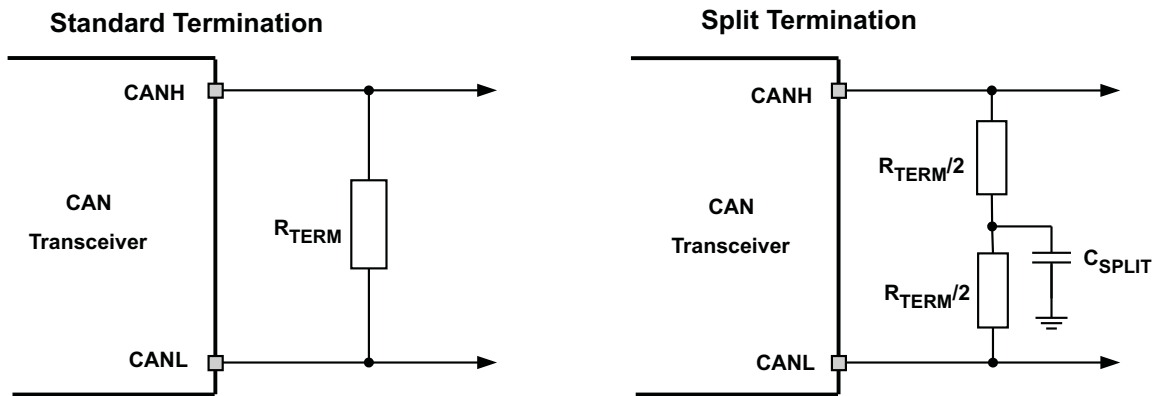

Figure 38. CAN Bus Termination Concepts

11.2.3 Application Curve

Figure 39 shows 3 typical output waveforms for the SN65HVD233 device with three different connections made to the R_S pin. The top waveform shows the typical differential signal when transitioning from a recessive level to a dominant level on the CAN bus with R_S tied to GND through a 0-Ω resistor. The second waveform shows the same signal for the condition with a 10-kΩ resistor tied from R_S to ground. The bottom waveform shows the typical differential signal for the case where a 100-kΩ resistor is tied from the R_S pin to ground.

Typical Application (continued)

Figure 39. Typical SN65HVD233 Output Waveforms With Different Slope Control Resistor Values

11.3 System Example

11.3.1 ISO 11898 Compliance of SN65HVD23x Family of 3.3-V CAN Transceivers

11.3.1.1 Introduction

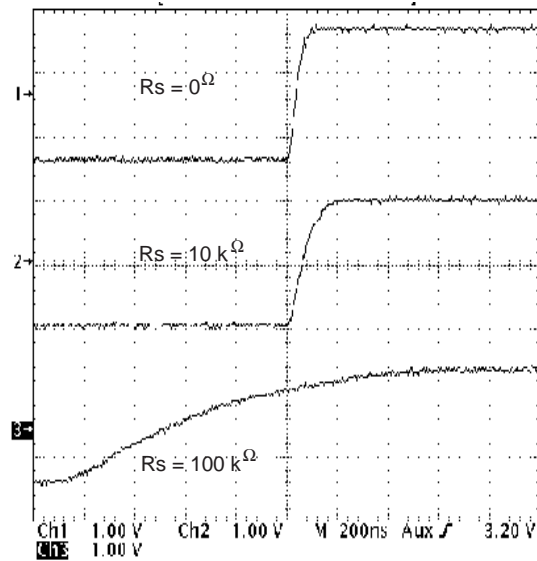
Many users value the low power consumption of operating their CAN transceivers from a 3.3-V supply. However, some are concerned about the interoperability with 5 V supplied transceivers on the same bus. This report analyzes this situation to address those concerns.

11.3.1.2 Differential Signal

CAN is a differential bus where complementary signals are sent over two wires and the voltage difference between the two wires defines the logical state of the bus. The differential CAN receiver monitors this voltage difference and outputs the bus state with a single ended logic level output signal.

System Example (continued)

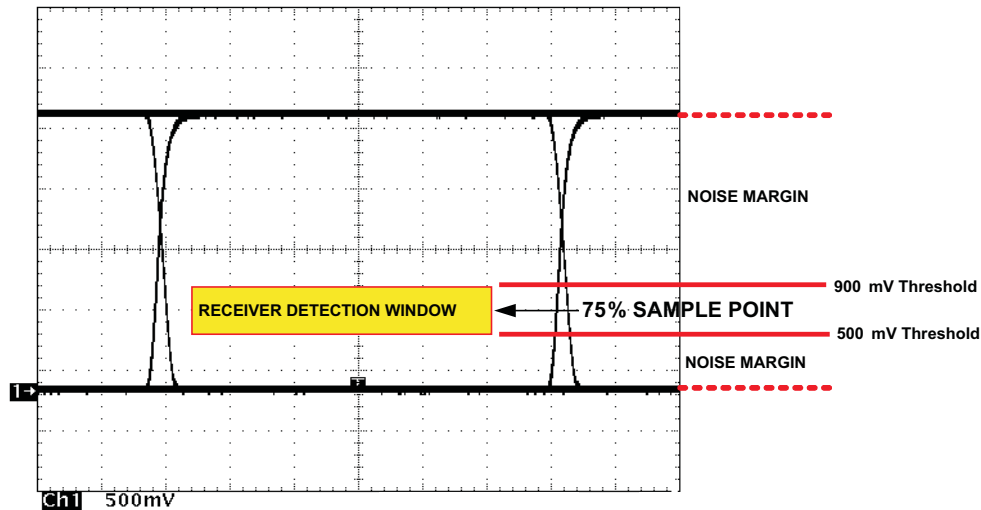

Figure 40. Typical SN65HVD230 Differential Output Voltage Waveform

The CAN driver creates the differential voltage between CANH and CANL in the dominant state. The dominant differential output of the SN65HVD23x is greater than 1.5 V and less than 3 V across a 60 ohm load as defined by the ISO 11898 standard. These are the same limiting values for 5 V supplied CAN transceivers. The bus termination resistors drive the recessive bus state and not the CAN driver.

A CAN receiver is required to output a recessive state when less than 500 mV of differential voltage exists on the bus, and a dominant state when more than 900 mV of differential voltage exists on the bus. The CAN receiver must do this with common-mode input voltages from -2 V to 7 V. The SN65HVD23x family receivers meet these same input specifications as 5 V supplied receivers.

11.3.1.3 Common-Mode Signal

A common-mode signal is an average voltage of the two signal wires that the differential receiver rejects. The common-mode signal comes from the CAN driver, ground noise, and coupled bus noise. Since the bias voltage of the recessive state of the device is dependent on V_{CC} , any noise present or variation of V_{CC} will have an effect on this bias voltage seen by the bus. The SN65HVD23x family has the recessive bias voltage set higher than $0.5 \cdot V_{CC}$ to comply with the ISO 11898-2 CAN standard. The caveat to this is that the common mode voltage will drop by a couple hundred millivolts when driving a dominant bit on the bus. This means that there is a common mode shift between the dominant bit and recessive bit states of the device. While this is not ideal, this small variation in the driver common-mode output is rejected by differential receivers and does not effect data, signal noise margins or error rates.

11.3.1.4 Interoperability of 3.3-V CAN in 5-V CAN Systems

The 3.3-V supplied SN65HVD23x family of CAN transceivers are fully compatible with 5-V CAN transceivers. The differential output voltage is the same, the recessive common mode output bias is the same, and the receivers have the same input specifications. The only slight difference is in the dominant common mode output voltage which is a couple hundred millivolts lower for 3.3-V CAN transceiver than 5-V supplied transceiver.

To help ensure the widest interoperability possible, the SN65HVD23x family has successfully passed the internationally recognized GIFT/ICT conformance and interoperability testing for CAN transceivers. Electrical interoperability does not always assure interchangeability however. Most implementers of CAN buses recognize that ISO 11898 does not sufficiently specify the electrical layer and that strict standard compliance alone does not ensure full interchangeability. This comes only with thorough equipment testing.

12 Power Supply Recommendations

To ensure reliable operation at all data rates and supply voltages, each supply should be decoupled with a 100-nF ceramic capacitor located as close to the V_{CC} supply pins as possible. The TPS76333 is a linear voltage regulator suitable for the 3.3 V supply.

13 Layout

13.1 Layout Guidelines

In order for the PCB design to be successful, start with design of the protection and filtering circuitry. Because ESD and EFT transients have a wide frequency bandwidth from approximately 3 MHz to 3 GHz, high frequency layout techniques must be applied during PCB design. On chip IEC ESD protection is good for laboratory and portable equipment but is usually not sufficient for EFT and surge transients occurring in industrial environments. Therefore robust and reliable bus node design requires the use of external transient protection devices at the bus connectors. Placement at the connector also prevents these harsh transient events from propagating further into the PCB and system.

Use V_{CC} and ground planes to provide low inductance.

NOTE

High frequency current follows the path of least inductance and not the path of least resistance.

Design the bus protection components in the direction of the signal path. Do not force the transient current to divert from the signal path to reach the protection device.

An example placement of the Transient Voltage Suppression (TVS) device indicated as D1 (either bi-directional diode or varistor solution) and bus filter capacitors C8 and C9 are shown in [Figure 41](#).

The bus transient protection and filtering components should be placed as close to the bus connector, J1, as possible. This prevents transients, ESD and noise from penetrating onto the board and disturbing other devices.

Bus termination: [Figure 41](#) shows split termination. This is where the termination is split into two resistors, R5 and R6, with the center or split tap of the termination connected to ground via capacitor C7. Split termination provides common mode filtering for the bus. When termination is placed on the board instead of directly on the bus, care must be taken to ensure the terminating node is not removed from the bus as this will cause signal integrity issues of the bus is not properly terminated on both ends. See the application section for information on power ratings needed for the termination resistor(s).

Bypass and bulk capacitors should be placed as close as possible to the supply pins of transceiver, examples C2, C3 (V_{CC}).

Use at least two vias for V_{CC} and ground connections of bypass capacitors and protection devices to minimize trace and via inductance.

To limit current of digital lines, serial resistors may be used. Examples are R1, R2, R3 and R4.

To filter noise on the digital IO lines, a capacitor may be used close to the input side of the IO as shown by C1 and C4.

Since the internal pullup and pulldown biasing of the device is weak for floating pins, an external 1-k Ω to 10-k Ω pullup or pulldown resistor should be used to bias the state of the pin more strongly against noise during transient events.

Pin 1: If an open drain host processor is used to drive the D pin of the device an external pull-up resistor between 1 k Ω and 10 k Ω and V_{CC} should be used to drive the recessive input state of the device.

Pin 8: is shown assuming the mode pin, RS, will be used. If the device will only be used in normal mode or slope control mode, R3 is not needed and the pads of C4 could be used for the pulldown resistor to GND.

13.2 Layout Example

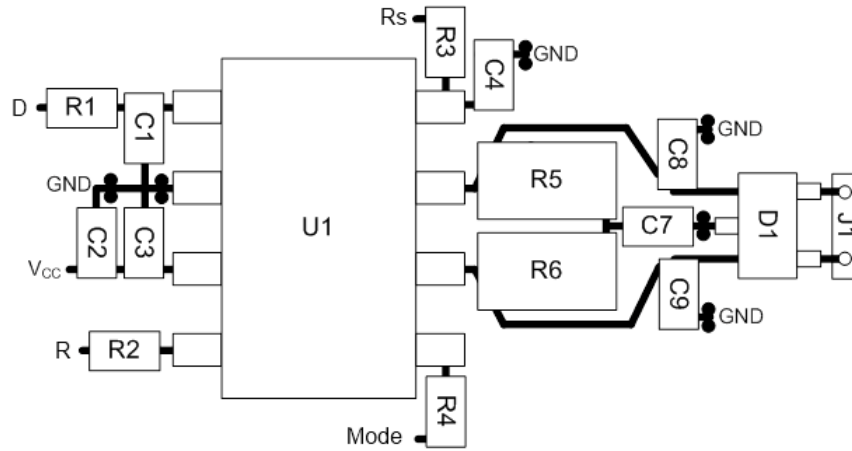

Figure 41. Layout Example Schematic

14 デバイスおよびドキュメントのサポート

14.1 関連リンク

次の表に、クイック・アクセス・リンクを示します。カテゴリには、技術資料、サポートおよびコミュニティ・リソース、ツールとソフトウェア、およびサンプル注文またはご購入へのクイック・アクセスが含まれます。

表 7. 関連リンク

製品	プロダクト・フォルダ	サンプルとご購入	技術資料	ツールとソフトウェア	サポートとコミュニティ
SN65HVD233	ここをクリック	ここをクリック	ここをクリック	ここをクリック	ここをクリック
SN65HVD234	ここをクリック	ここをクリック	ここをクリック	ここをクリック	ここをクリック
SN65HVD235	ここをクリック	ここをクリック	ここをクリック	ここをクリック	ここをクリック

14.2 ドキュメントの更新通知を受け取る方法

ドキュメントの更新についての通知を受け取るには、ti.comのデバイス製品フォルダを開いてください。右上の隅にある「通知を受け取る」をクリックして登録すると、変更されたすべての製品情報に関するダイジェストを毎週受け取れます。変更の詳細については、修正されたドキュメントに含まれている改訂履歴をご覧ください。

14.3 コミュニティ・リソース

The following links connect to TI community resources. Linked contents are provided "AS IS" by the respective contributors. They do not constitute TI specifications and do not necessarily reflect TI's views; see TI's [Terms of Use](#).

TI E2E™オンライン・コミュニティ *TIのE2E (Engineer-to-Engineer) コミュニティ*。エンジニア間の共同作業を促進するために開設されたものです。e2e.ti.comでは、他のエンジニアに質問し、知識を共有し、アイデアを検討して、問題解決に役立てることができます。

設計サポート *TIの設計サポート* 役に立つE2Eフォーラムや、設計サポート・ツールをすばやく見つけることができます。技術サポート用の連絡先情報も参照できます。

14.4 商標

E2E is a trademark of Texas Instruments.
All other trademarks are the property of their respective owners.

14.5 静電気放電に関する注意事項



これらのデバイスは、限定的なESD(静電破壊)保護機能を内蔵しています。保存時または取り扱い時は、MOSゲートに対する静電破壊を防止するために、リード線同士をショートさせておくか、デバイスを導電フォームに入れる必要があります。

14.6 Glossary

[SLYZ022](#) — *TI Glossary*.

This glossary lists and explains terms, acronyms, and definitions.

15 メカニカル、パッケージ、および注文情報

以降のページには、メカニカル、パッケージ、および注文に関する情報が記載されています。この情報は、そのデバイスについて利用可能な最新のデータです。このデータは予告なく変更されることがあり、ドキュメントが改訂される場合もあります。本データシートのブラウザ版を使用されている場合は、画面左側の説明をご覧ください。

PACKAGING INFORMATION

Orderable Device	Status (1)	Package Type	Package Drawing	Pins	Package Qty	Eco Plan (2)	Lead finish/ Ball material (6)	MSL Peak Temp (3)	Op Temp (°C)	Device Marking (4/5)	Samples
SN65HVD233D	OBSOLETE	SOIC	D	8		TBD	Call TI	Call TI	-40 to 125	VP233	
SN65HVD233DR	ACTIVE	SOIC	D	8	2500	RoHS & Green	NIPDAU	Level-1-260C-UNLIM	-40 to 125	VP233	Samples
SN65HVD233DRG4	ACTIVE	SOIC	D	8	2500	RoHS & Green	NIPDAU	Level-1-260C-UNLIM	-40 to 125	VP233	Samples
SN65HVD234D	OBSOLETE	SOIC	D	8		TBD	Call TI	Call TI	-40 to 125	VP234	
SN65HVD234DR	ACTIVE	SOIC	D	8	2500	RoHS & Green	NIPDAU	Level-1-260C-UNLIM	-40 to 125	VP234	Samples
SN65HVD234DRG4	ACTIVE	SOIC	D	8	2500	RoHS & Green	NIPDAU	Level-1-260C-UNLIM	-40 to 125	VP234	Samples
SN65HVD235D	OBSOLETE	SOIC	D	8		TBD	Call TI	Call TI	-40 to 125	VP235	
SN65HVD235DR	ACTIVE	SOIC	D	8	2500	RoHS & Green	NIPDAU	Level-1-260C-UNLIM	-40 to 125	VP235	Samples

(1) The marketing status values are defined as follows:

ACTIVE: Product device recommended for new designs.

LIFEBUY: TI has announced that the device will be discontinued, and a lifetime-buy period is in effect.

NRND: Not recommended for new designs. Device is in production to support existing customers, but TI does not recommend using this part in a new design.

PREVIEW: Device has been announced but is not in production. Samples may or may not be available.

OBSOLETE: TI has discontinued the production of the device.

(2) **RoHS:** TI defines "RoHS" to mean semiconductor products that are compliant with the current EU RoHS requirements for all 10 RoHS substances, including the requirement that RoHS substance do not exceed 0.1% by weight in homogeneous materials. Where designed to be soldered at high temperatures, "RoHS" products are suitable for use in specified lead-free processes. TI may reference these types of products as "Pb-Free".

RoHS Exempt: TI defines "RoHS Exempt" to mean products that contain lead but are compliant with EU RoHS pursuant to a specific EU RoHS exemption.

Green: TI defines "Green" to mean the content of Chlorine (Cl) and Bromine (Br) based flame retardants meet JS709B low halogen requirements of <=1000ppm threshold. Antimony trioxide based flame retardants must also meet the <=1000ppm threshold requirement.

(3) MSL, Peak Temp. - The Moisture Sensitivity Level rating according to the JEDEC industry standard classifications, and peak solder temperature.

(4) There may be additional marking, which relates to the logo, the lot trace code information, or the environmental category on the device.

(5) Multiple Device Markings will be inside parentheses. Only one Device Marking contained in parentheses and separated by a "-" will appear on a device. If a line is indented then it is a continuation of the previous line and the two combined represent the entire Device Marking for that device.

(6) Lead finish/Ball material - Orderable Devices may have multiple material finish options. Finish options are separated by a vertical ruled line. Lead finish/Ball material values may wrap to two lines if the finish value exceeds the maximum column width.

Important Information and Disclaimer:The information provided on this page represents TI's knowledge and belief as of the date that it is provided. TI bases its knowledge and belief on information provided by third parties, and makes no representation or warranty as to the accuracy of such information. Efforts are underway to better integrate information from third parties. TI has taken and continues to take reasonable steps to provide representative and accurate information but may not have conducted destructive testing or chemical analysis on incoming materials and chemicals. TI and TI suppliers consider certain information to be proprietary, and thus CAS numbers and other limited information may not be available for release.

In no event shall TI's liability arising out of such information exceed the total purchase price of the TI part(s) at issue in this document sold by TI to Customer on an annual basis.

OTHER QUALIFIED VERSIONS OF SN65HVD233, SN65HVD234, SN65HVD235 :

- Automotive : [SN65HVD233-Q1](#), [SN65HVD234-Q1](#), [SN65HVD235-Q1](#)
- Enhanced Product : [SN65HVD233-EP](#)

NOTE: Qualified Version Definitions:

- Automotive - Q100 devices qualified for high-reliability automotive applications targeting zero defects
- Enhanced Product - Supports Defense, Aerospace and Medical Applications

TAPE AND REEL INFORMATION

QUADRANT ASSIGNMENTS FOR PIN 1 ORIENTATION IN TAPE

*All dimensions are nominal

Device	Package Type	Package Drawing	Pins	SPQ	Reel Diameter (mm)	Reel Width W1 (mm)	A0 (mm)	B0 (mm)	K0 (mm)	P1 (mm)	W (mm)	Pin1 Quadrant
SN65HVD233DR	SOIC	D	8	2500	330.0	12.4	6.4	5.2	2.1	8.0	12.0	Q1
SN65HVD234DR	SOIC	D	8	2500	330.0	12.4	6.4	5.2	2.1	8.0	12.0	Q1
SN65HVD235DR	SOIC	D	8	2500	330.0	12.4	6.4	5.2	2.1	8.0	12.0	Q1

TAPE AND REEL BOX DIMENSIONS



*All dimensions are nominal

Device	Package Type	Package Drawing	Pins	SPQ	Length (mm)	Width (mm)	Height (mm)
SN65HVD233DR	SOIC	D	8	2500	340.5	338.1	20.6
SN65HVD234DR	SOIC	D	8	2500	340.5	338.1	20.6
SN65HVD235DR	SOIC	D	8	2500	340.5	338.1	20.6



D0008A

PACKAGE OUTLINE

SOIC - 1.75 mm max height

SMALL OUTLINE INTEGRATED CIRCUIT



4214825/C 02/2019

NOTES:

- Linear dimensions are in inches [millimeters]. Dimensions in parenthesis are for reference only. Controlling dimensions are in inches. Dimensioning and tolerancing per ASME Y14.5M.
- This drawing is subject to change without notice.
- This dimension does not include mold flash, protrusions, or gate burrs. Mold flash, protrusions, or gate burrs shall not exceed $.006$ [0.15] per side.
- This dimension does not include interlead flash.
- Reference JEDEC registration MS-012, variation AA.

EXAMPLE BOARD LAYOUT

D0008A

SOIC - 1.75 mm max height

SMALL OUTLINE INTEGRATED CIRCUIT



LAND PATTERN EXAMPLE
EXPOSED METAL SHOWN
SCALE:8X



SOLDER MASK DETAILS

4214825/C 02/2019

NOTES: (continued)

6. Publication IPC-7351 may have alternate designs.

7. Solder mask tolerances between and around signal pads can vary based on board fabrication site.

EXAMPLE STENCIL DESIGN

D0008A

SOIC - 1.75 mm max height

SMALL OUTLINE INTEGRATED CIRCUIT



SOLDER PASTE EXAMPLE
BASED ON .005 INCH [0.125 MM] THICK STENCIL
SCALE:8X

4214825/C 02/2019

NOTES: (continued)

8. Laser cutting apertures with trapezoidal walls and rounded corners may offer better paste release. IPC-7525 may have alternate design recommendations.
9. Board assembly site may have different recommendations for stencil design.

重要なお知らせと免責事項

TI は、技術データと信頼性データ (データシートを含みます)、設計リソース (リファレンス・デザインを含みます)、アプリケーションや設計に関する各種アドバイス、Web ツール、安全性情報、その他のリソースを、欠陥が存在する可能性のある「現状のまま」提供しており、商品性および特定目的に対する適合性の黙示保証、第三者の知的財産権の非侵害保証を含むいかなる保証も、明示的または黙示的にかかわらず拒否します。

これらのリソースは、TI 製品を使用する設計の経験を積んだ開発者への提供を意図したものです。(1) お客様のアプリケーションに適した TI 製品の選定、(2) お客様のアプリケーションの設計、検証、試験、(3) お客様のアプリケーションに該当する各種規格や、その他のあらゆる安全性、セキュリティ、規制、または他の要件への確実な適合に関する責任を、お客様のみが単独で負うものとし、

上記の各種リソースは、予告なく変更される可能性があります。これらのリソースは、リソースで説明されている TI 製品を使用するアプリケーションの開発の目的でのみ、TI はその使用をお客様に許諾します。これらのリソースに関して、他の目的で複製することや掲載することは禁止されています。TI や第三者の知的財産権のライセンスが付与されている訳ではありません。お客様は、これらのリソースを自身で使用した結果発生するあらゆる申し立て、損害、費用、損失、責任について、TI およびその代理人を完全に補償するものとし、TI は一切の責任を拒否します。

TI の製品は、[TI の販売条件](#)、または [ti.com](#) やかかる TI 製品の関連資料などのいずれかを通じて提供する適用可能な条項の下で提供されています。TI がこれらのリソースを提供することは、適用される TI の保証または他の保証の放棄の拡大や変更を意味するものではありません。

お客様がいかなる追加条項または代替条項を提案した場合でも、TI はそれらに異議を唱え、拒否します。

郵送先住所 : Texas Instruments, Post Office Box 655303, Dallas, Texas 75265
Copyright © 2024, Texas Instruments Incorporated