

Table of Contents

1 特長	1	8.3 Feature Description.....	14
2 アプリケーション	1	8.4 Device Functional Modes.....	15
3 概要	1	9 Application and Implementation	17
4 Revision History	2	9.1 Application Information.....	17
5 Pin Configuration and Functions	3	9.2 Typical Application.....	18
6 Specifications	4	10 Power Supply Recommendations	20
6.1 Absolute Maximum Ratings.....	4	11 Layout	21
6.2 ESD Ratings.....	4	11.1 Layout Guidelines.....	21
6.3 Recommended Operating Conditions.....	4	11.2 Layout Example.....	21
6.4 Thermal Information.....	5	12 Device and Documentation Support	22
6.5 Electrical Characteristics.....	6	12.1 Documentation Support.....	22
6.6 Switching Characteristics.....	7	12.2 Receiving Notification of Documentation Updates..	22
6.7 Typical Characteristics.....	8	12.3 Support Resources.....	22
7 Parameter Measurement Information	11	12.4 Trademarks.....	22
8 Detailed Description	14	12.5 Electrostatic Discharge Caution.....	22
8.1 Overview.....	14	12.6 Glossary.....	22
8.2 Functional Block Diagram.....	14		

4 Revision History

DATE	REVISION	NOTES
October 2020	*	Initial release.

5 Pin Configuration and Functions



图 5-1. RGT Package, 16-Pin VQFN, Top View

表 5-1. Pin Functions

PIN			DESCRIPTION
NAME	NO.	TYPE	
BIAS	10	O	Bias voltage output for setting driver output power by external resistors
DIR	5	O	Direction control output signal for bus arbitration
DIRSET1	7	—	DIRSET1 and DIRSET2: Bits to set the duration of DIR DIRSET[2:1]: [L:L] = 9.6 kbps; [L:H] = 38.4 kbps; [H:L] = 115 kbps; [H:H] = standby mode
DIRSET2	6	—	
GND	8	—	Ground
	16		
RES	9	P	Input voltage to adjust driver output power that is set by external resistors from BIAS pin to GND
RXIN	11	I	Modulated input signal to the receiver
RXOUT	4	O	Digital data bit stream from receiver
SYNCOUT	1	O	Open-drain output to synchronize other devices to the 4x-carrier oscillator at XTAL1 and XTAL2
TXIN	2	I	Digital data bit stream to driver
TXOUT	12	O	Modulated output signal from the driver
V _{CC}	13	P	Analog supply voltage for the device
VL	3	P	Logic supply voltage for the device
XTAL1	14	I/O	I/O pins of the crystal oscillator. Connect a $4 \times f_C$ crystal between these pins or connect XTAL1 to an 8.704-MHz clock and connect XTAL2 to GND.
XTAL2	15		
EP	—	—	Exposed pad. Connection to ground plane is recommended for best thermal conduction.

6 Specifications

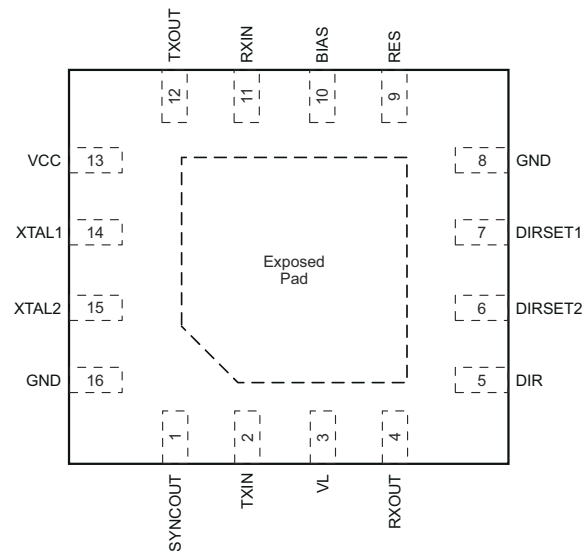
6.1 Absolute Maximum Ratings

See (1)

	MIN	MAX	UNIT
Supply voltage, V_{CC} and V_L	-0.5	6	V
Voltage at coax pins	-0.5	6	V
Voltage at logic pins	-0.3	$V_{VL} + 0.3$	V
Logic output current	-20	20	mA
TXOUT output current	Internally limited		
SYNCOU output current	Internally limited		
Junction temperature, T_J		170	°C
Continuous total power dissipation	See the <i>Thermal Information</i>		
Storage temperature, T_{stg} (2)	-65	150	°C

- (1) Stresses beyond those listed under *Absolute Maximum Ratings* may cause permanent damage to the device. These are stress ratings only and functional operation of the device at these or any other conditions beyond those indicated under *Recommended Operating Conditions* is not implied. Exposure to absolute-maximum-rated conditions for extended periods may affect device reliability.
- (2) Applicable before the device is installed in the final product.

6.2 ESD Ratings

	VALUE	UNIT
$V_{(ESD)}$ Electrostatic discharge Human-body model (HBM), per ANSI/ESDA/JEDEC JS-001(1)	±2000	V

- (1) JEDEC document JEP155 states that 500-V HBM allows safe manufacturing with a standard ESD control process.

6.3 Recommended Operating Conditions

	MIN	NOM	MAX	UNIT
V_{CC} Analog supply voltage	3		5.5	V
V_L Logic supply voltage	1.6		5.5	V
$V_{I(pp)}$ Input signal amplitude at RXIN			1.12	V _{pp}
V_{IH} High-level input voltage	TXIN, DIRSET1, DIRSET2		$70\%V_L$	V_L
	XTAL1, XTAL2		$70\%V_{CC}$	V_{CC}
V_{IL} Low-level input voltage	TXIN, DIRSET1, DIRSET2		0	$30\%V_L$
	XTAL1, XTAL2		0	$30\%V_{CC}$
$1/t_{UI}$ Data signaling rate	9.6		115	kbps
F_{OSC} Oscillator frequency	-30 ppm	8.704	30 ppm	MHz
Z_{LOAD} Load impedance between TXOUT to RXIN				Ω
	Load impedance between RXIN and GND at f_C (channel)			Ω
R1 Bias resistor between BIAS and RES				kΩ
R2 Bias resistor between RES and GND				kΩ
R_{SYNC} Pullup resistor between SYNCOU and V_{CC}				kΩ
V_{RES} Voltage at RES pin	0.7		1.5	V
C_C Coupling capacitance between RXIN and coax (channel)				nF
C_{BIAS} Capacitance between BIAS and GND				μF
T_A Operating free-air temperature	-40		120	°C
T_J Junction temperature	-40		125	°C

6.4 Thermal Information

THERMAL METRIC ⁽¹⁾		VQFN	UNIT
		RGT 16 Pins	
$R_{\theta JA}$	Junction-to-ambient thermal resistance	49.4	°C/W
$R_{\theta JCtop}$	Junction-to-case (top) thermal resistance	64.2	°C/W
$R_{\theta JB}$	Junction-to-board thermal resistance	22.9	°C/W
Ψ_{JT}	Junction-to-top characterization parameter	1.7	°C/W
Ψ_{JB}	Junction-to-board characterization parameter	22.9	°C/W
$R_{\theta JCbot}$	Junction-to-case (bottom) thermal resistance	25	°C/W

- (1) For more information about traditional and new thermal metrics, see the [Semiconductor and IC Package Thermal Metrics](#) application report.

6.5 Electrical Characteristics

over recommended operating conditions (unless otherwise noted)

PARAMETER		TEST CONDITIONS	MIN	TYP	MAX	UNIT
POWER SUPPLY						
I_{CC}	Supply current	DIRSET1 = L DIRSET2 = H	TXIN = L (active)	28	33	mA
			TXIN = H (quiescent)	25	31	
			TXIN = 115 kbps, 50% duty cycle	27	33	
		DIRSET1 = H, DIRSET2 = H (standby)	12	17		
I_{VL}	Logic supply current	TXIN = H, RXIN = DC input			50	μ A
PSRR	Receiver power supply rejection ratio	$V_{TXIN} = V_L$	45	60		dB
T_{SD_RISE}	Thermal shutdown rising		143	156	170	$^{\circ}$ C
T_{SD_FALL}	Thermal shutdown falling		123	136	147	$^{\circ}$ C
T_{SD_HYS}	Thermal shutdown hysteresis		18	20	23	$^{\circ}$ C
LOGIC PINS						
V_{OH}	High-level logic output voltage (RXOUT, DIR)	$I_{OH} = -4$ mA for $V_L > 2.4$ V, $I_{OH} = -2$ mA for $V_L < 2.4$ V	90% V_{VL}			V
V_{OL}	Low-level logic output voltage (RXOUT, DIR)	$I_{OL} = 4$ mA for $V_L > 2.4$ V, $I_{OL} = 2$ mA for $V_L < 2.4$ V			10% V_{VL}	V
COAX DRIVER						
$V_{O(PP)}$	Peak-to-peak output voltage at device pin TXOUT (see 7-1)	$V_{RES} = 1.5$ V (Maximum setting)	2.24	2.5		V_{PP}
		$V_{RES} = 0.7$ V (Minimum setting)		1.17	1.3	
$V_{O(PP)}$	Peak-to-peak voltage at coax out (see 7-1)	$V_{RES} = 1.5$ V	5	6		dBm
		$V_{RES} = 0.7$ V		-0.6	0.3	
$V_{O(OFF)}$	Off-state output voltage	At TXOUT			1	mVpp
		At coax out			-60	dBm
	Output emissions	Coupled to coaxial cable with characteristic impedance of 50 Ω , as shown in 6-1 ⁽¹⁾ ⁽²⁾				N/A
f_O	Output frequency			2.176		MHz
Δf	Output frequency variation		-100		100	ppm
Z_O	Output impedance	At 100 kHz		0.03		Ω
		At 10 MHz		3.5		
$ I_{OS} $	Short-circuit output current	TXOUT is also protected by a thermal shutdown circuit during short-circuit faults		300	450	mA
COAX RECEIVER						
V_{IT}	Input threshold	$f_{IN} = 2.176$ MHz	79	112	158	mVPP
			-18	-15	-12	dBm
Z_{IN}	Input impedance	$f = f_O$	11	21		k Ω
RECEIVER FILTER						
f_{PB}	Passband	VRXIN = 1.12VP_P	1.1		4.17	MHz
f_{REJ}	Receiver rejection range	2.176-MHz carrier amplitude of 112.4 mVpp, frequency band of spurious components with 800 mVPP allowed.	1.1		4.17	MHz
$t_{noise\ filter}$	Receiver noise filter time (slow bit rate)	DIRSET for 9.6 kbps		4		μ s
	Receiver noise filter time (fast bit rate)	DIRSET for > 9.6 kbps		2		μ s
XTAL AND SYNC						
I_I	Input leakage current	XTAL1, XTAL2, 0V < V_{IN} < V_{CC}	-15		15	μ A
V_{OL}	Output low voltage	SYNCOOUT, with 1-k Ω resistor from SYNCOOUT to V_{CC}			0.4	V

- (1) Specified by design with a recommended 470-pF capacitor between RXIN and GND. Measurements above 150 MHz are determined by setup.
- (2) Conforms to AISG spectrum emissions mask, 3GPP TS 25.461, see [7-3](#).

6.6 Switching Characteristics

over recommended operating conditions (unless otherwise noted)

PARAMETER		TEST CONDITIONS	MIN	TYP	MAX	UNIT
t_{pAQ}, t_{pQA}	Coax driver propagation delay	See 7-1			5	μs
t_r, t_f	Coax receiver output rise/fall time	$C_L = 15 \text{ pF}, R_L = 1 \text{ k}\Omega$; see 7-1			20	ns
t_{PHL}, t_{PLH}	Receiver propagation delay	See 7-2		5.5	11	μs
	Coax receiver output duty cycle	$V_{RXIN(ON)} = 630 \text{ mVpp}, V_{RXIN(OFF)} < 5 \text{ mVpp}$, 50% duty cycle	40%		60%	
		$V_{RXIN(ON)} = 200 \text{ mVpp}, V_{RXIN(OFF)} < 5 \text{ mVpp}$, 50% duty cycle	40%		60%	
t_{DIR}	Direction control active duration	DIRSET2 = GND or OPEN, DIRSET1 = GND or OPEN		1667		μs
		DIRSET2 = GND, DIRSET1 = VL		417		
		DIRSET2 = VL, DIRSET1 = VL		137		
$t_{DIRSKEW}$	Direction control skew (DIR to RXOUT)		270			ns
t_{dis}	Standby disable delay	300 mV _{PP} at 2.176 MHz on RXIN		2		ms
t_{en}	Standby enable delay	300 mV _{PP} at 2.176 MHz on RXIN		2		ms

6.7 Typical Characteristics

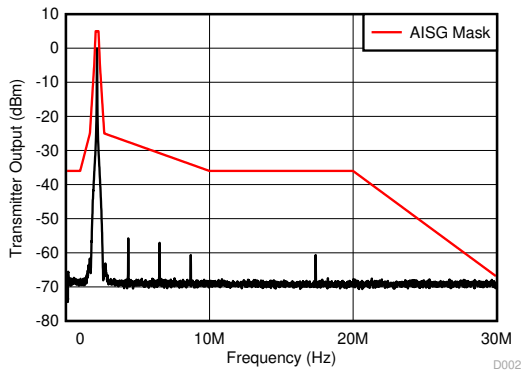

50% Duty Cycle $C_F = 470 \text{ pF}$

6-1. Low-Frequency Emissions Spectrum With 9.6-kbps Signaling Rate

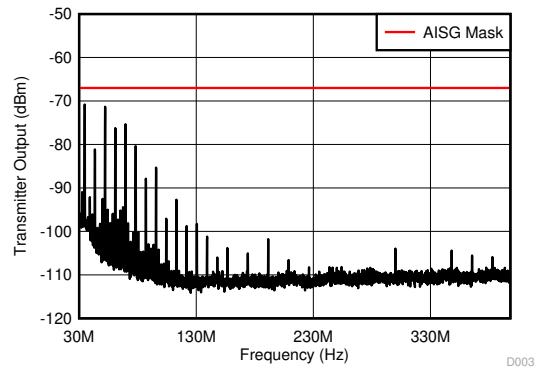

50% Duty Cycle $C_F = 470 \text{ pF}$

6-2. High-Frequency Emissions Spectrum With 9.6-kbps Signaling Rate

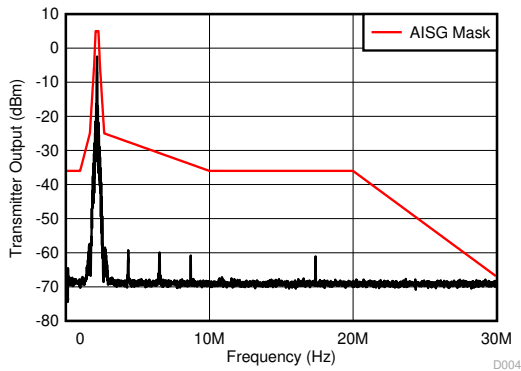

50% Duty Cycle $C_F = 470 \text{ pF}$

6-3. Low-Frequency Emissions Spectrum With 38.4-kbps Signaling Rate

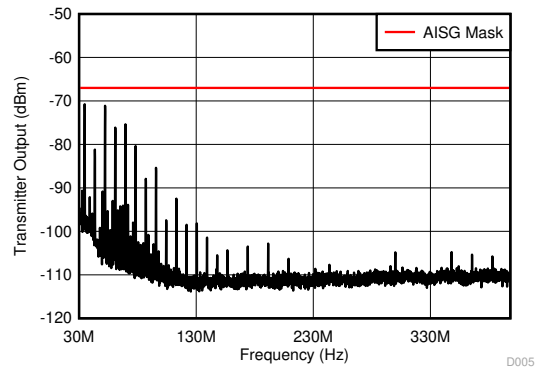

50% Duty Cycle $C_F = 470 \text{ pF}$

6-4. High-Frequency Emissions Spectrum With 38.4-kbps Signaling Rate

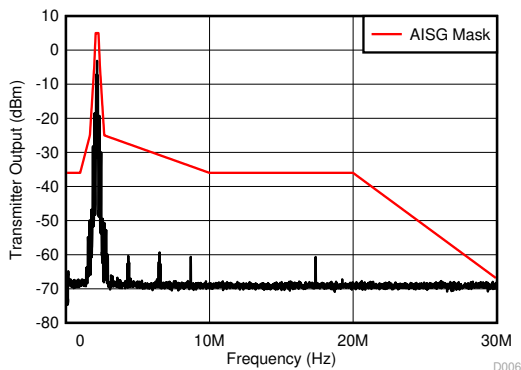

50% Duty Cycle $C_F = 470 \text{ pF}$

6-5. Low-Frequency Emissions Spectrum With 115.2-kbps Signaling Rate

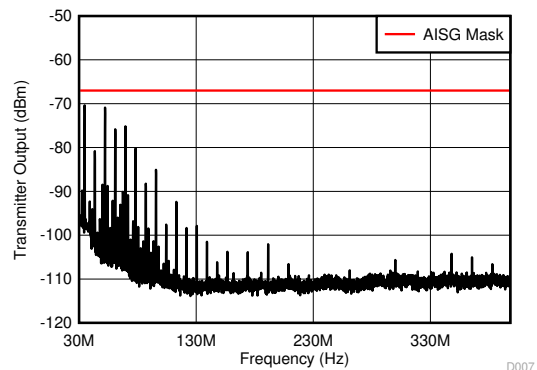

50% Duty Cycle $C_F = 470 \text{ pF}$

6-6. High-Frequency Emissions Spectrum With 115.2-kbps Signaling Rate

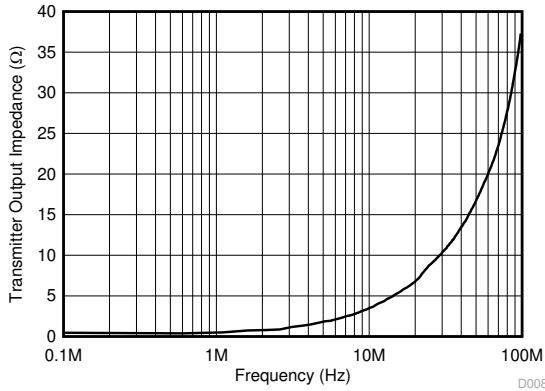

6-7. Transmitter Output Impedance

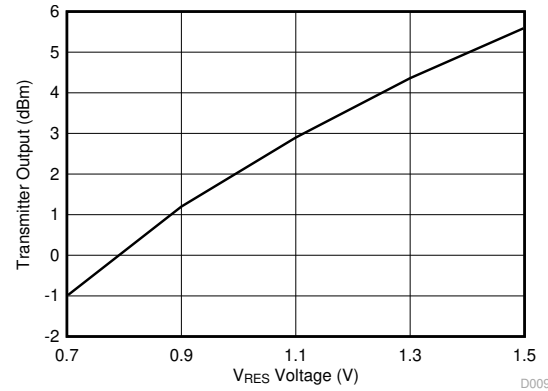

6-8. Transmit Power Adjustment

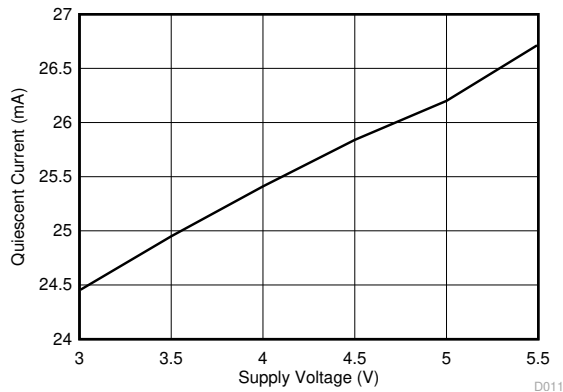

TXIN = VL

6-9. Supply Current vs Supply Voltage While Transmitting

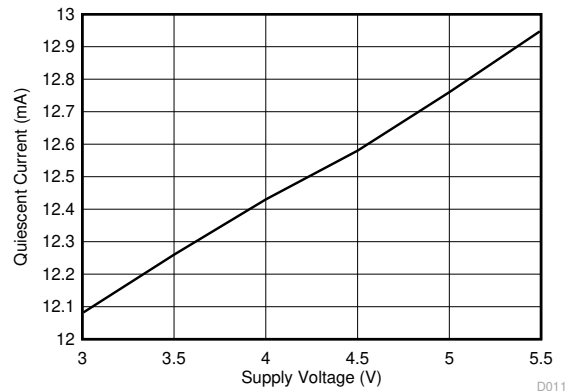

TXIN = VL

6-10. Supply Current vs Supply Voltage in Standby Mode

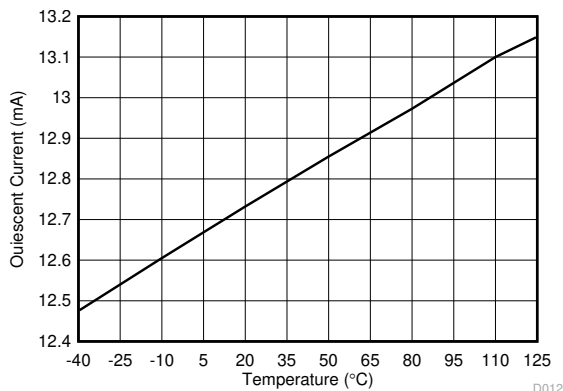

6-11. Supply Current vs Temperature in Standby Mode

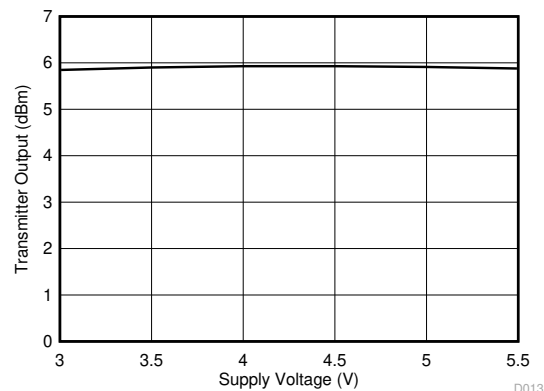

6-12. Transmitter Output Power vs Supply Voltage

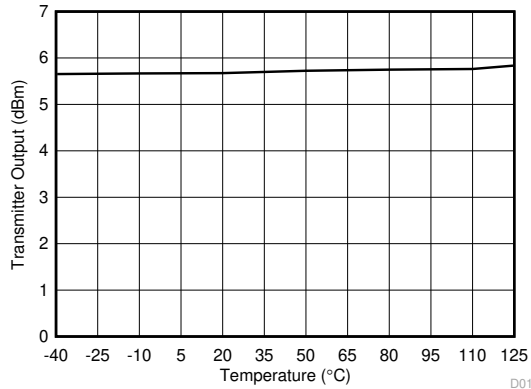

Figure 6-13. Transmitter Output Power vs Temperature

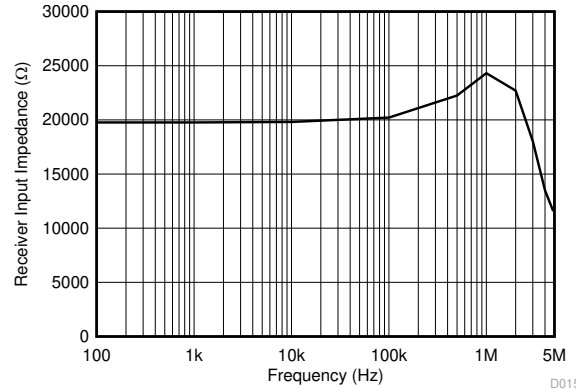

Figure 6-14. Receiver Input Impedance vs Frequency

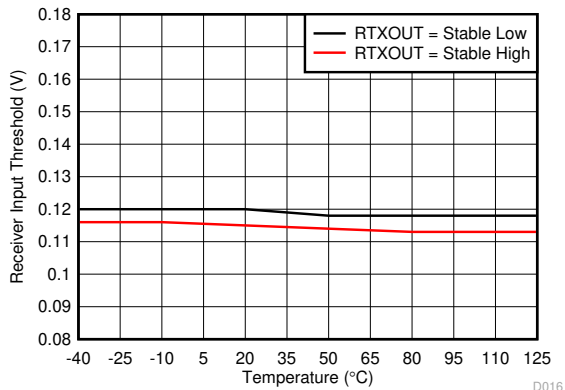

Figure 6-15. Receiver Input Threshold vs Temperature

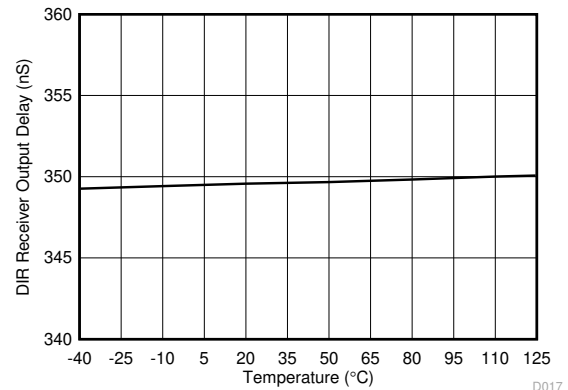

Figure 6-16. DIR Output Delay vs Temperature

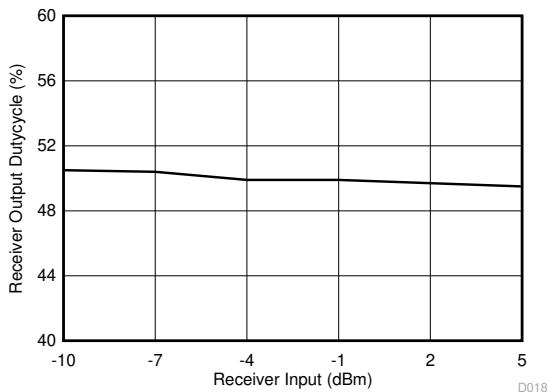

Figure 6-17. Receiver Duty Cycle With 9.6 kbps Signaling Rate

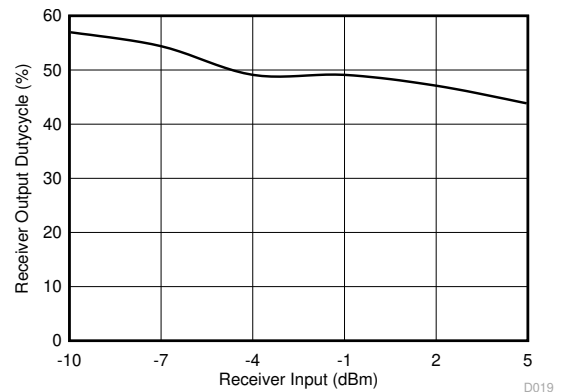
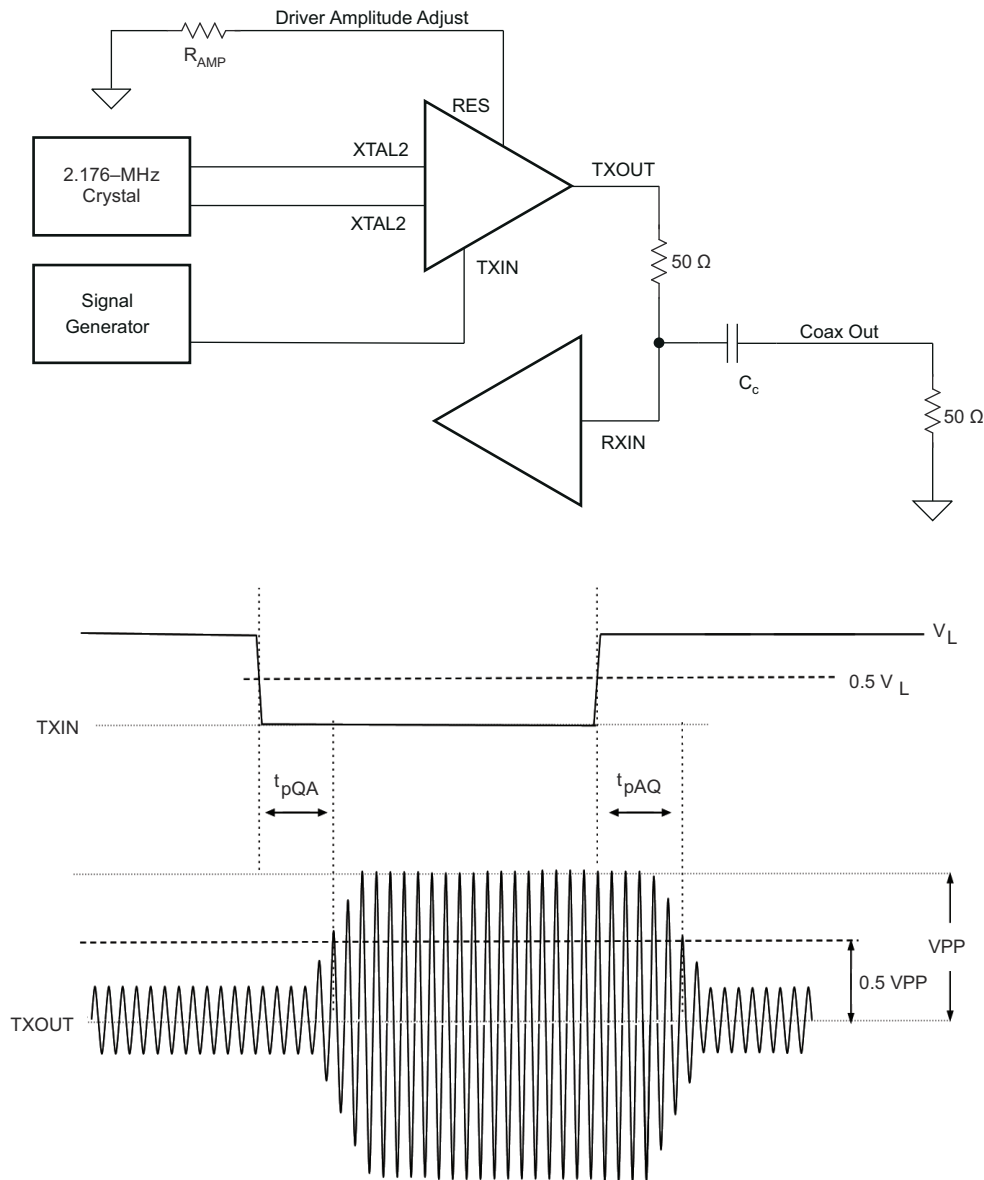

Figure 6-18. Receiver Duty Cycle With 115.2 kbps Signaling Rate

7 Parameter Measurement Information

Signal generator rate is 115 kbps, 50% duty cycle. Rise and fall times are less than 6 ns, and nominal output levels are 0 V and 3 V. Coupling capacitor, C_C , is 220 nF.



7-1. Measurement of Modem Driver Output Voltage With 50- Ω Loads

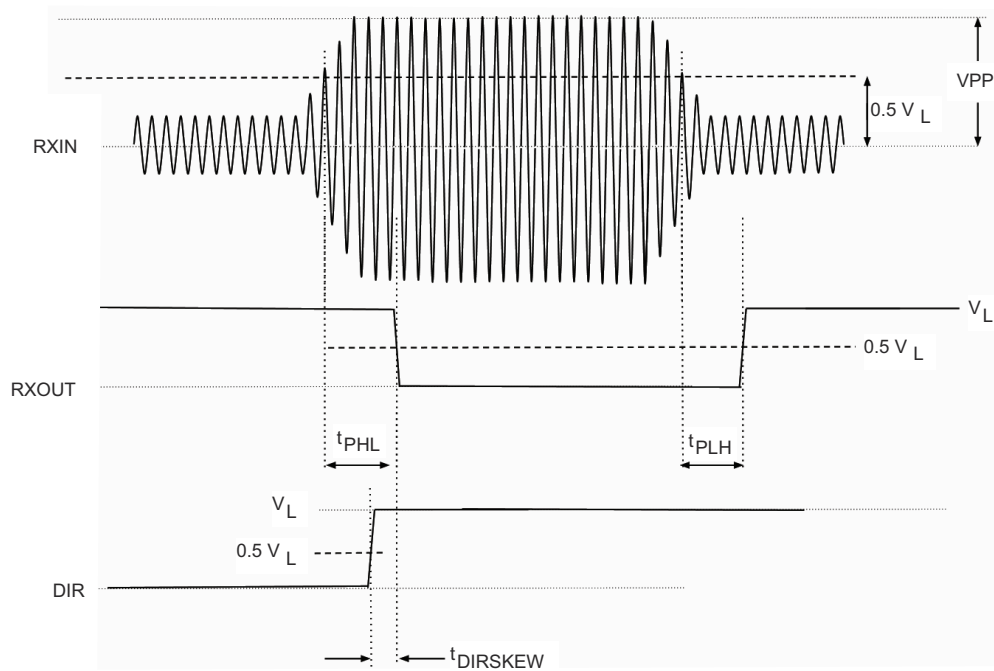
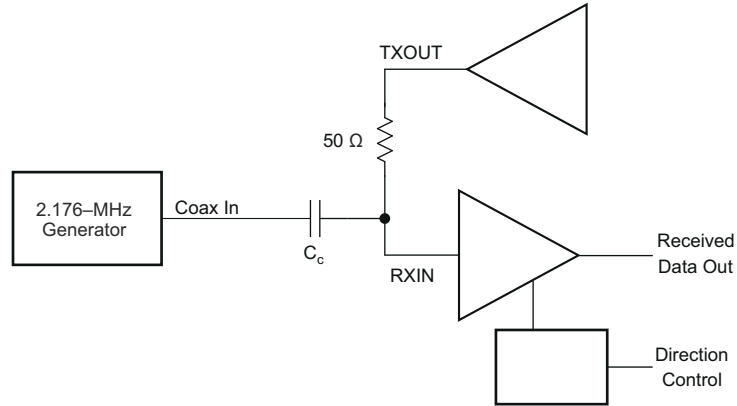

7-2. Measurement of Modem Receiver Propagation Delays

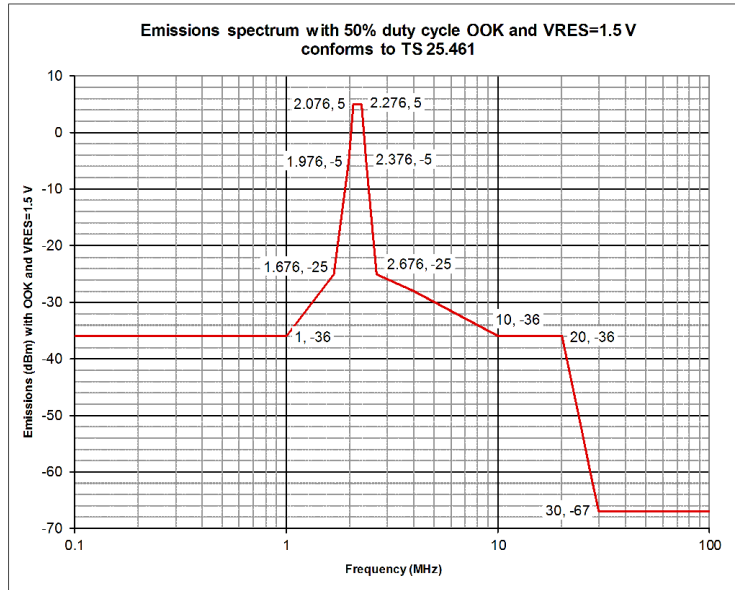

7-3. AISG Emissions Template

8 Detailed Description

8.1 Overview

The SN65HVD64 transceiver modulates and demodulates signals between the logic (baseband) and a frequency suitable for long coaxial media. The SN65HVD64 device is an integrated AISG transceiver designed to meet the requirements of the Antenna Interface Standards Group v2.0 and v3.0 specification. The SN65HVD64 receiver integrates an active bandpass filter to enable demodulation of signals even in the presence of spurious frequency components. The filter has a 2.176-MHz center frequency. The transmitter supports adjustable output power levels from 0 dBm to 6 dBm delivered to the 50-Ω coax cable. The SN65HVD64 transmitter is compliant with the spectrum emission requirement provided by the AISG standard. A direction control output facilitates bus arbitration for an RS-485 interface. This device integrates an oscillator input for a crystal, and also accepts standard clock inputs to the oscillator.

8.2 Functional Block Diagram

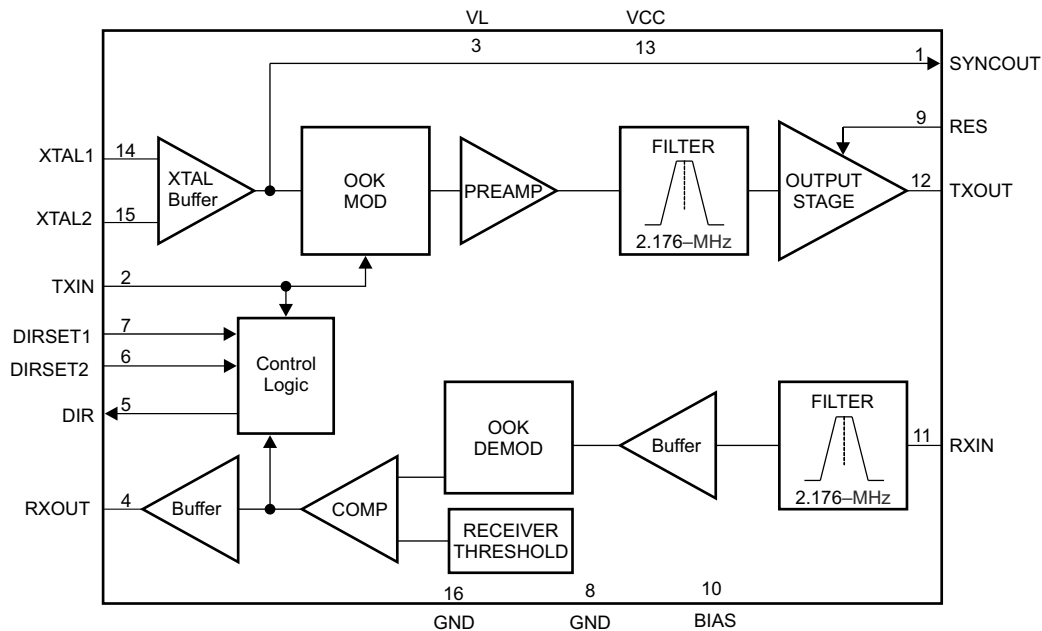

8.3 Feature Description

8.3.1 Coaxial Interface

The SN65HVD64 transceiver enables the transfer of data between radio equipment by modulating baseband data to a carrier frequency of 2.176 MHz (per the AISG standard). The transmitter output amplitude can be configured from 0 dBm to 6 dBm in order to communicate over a variety of different links, and the output emissions spectrum is designed to be compliant to AISG limits. The receiver features an active bandpass filter circuit that helps to separate the carrier frequency data from other spurious frequency components.

8.3.2 Reference Input

The 2.176-MHz modulation frequency is derived from an input reference that is nominally 8.704 MHz. The input reference can come either from a crystal or from an oscillator circuit with a tolerance of up to 30 ppm.

8.3.3 RS-485 Direction Control

To facilitate bus arbitration of an RS-485 interface, the SN65HVD64 provides a direction control output that can be used to control the enable/disable controls of an RS-485 transceiver. The direction control output automatically toggles based on activity present on the coaxial input interface, and has an adjustable time constant (controlled by the DIRSET1 and DIRSET2 pins) in order to accommodate various signaling rates.

8.4 Device Functional Modes

If DIRSET1 and DIRSET2 are in a logic high state, the device will be in standby mode. While in standby mode, the receiver functions normally, detecting carrier frequency activity on the RXIN pin and setting the RXOUT state. The transmitter circuits are not active in standby mode, thus the TXOUT pin is idle regardless of the logic state of TXIN. The supply current in standby mode is significantly reduced, allowing power savings when the node is not transmitting.

When not in standby mode, the default power-on state is idle. When in idle mode, RXOUT is high, and TXOUT is quiet. The device transitions to receive mode when a valid modulated signal is detected on the RXIN line or the device transitions to transmit mode when TXIN goes low. The device stays in either receive or transmit mode until DIR time-out (nominal 16 bit times) after the last activity on RXOUT or TXIN.

When in receive mode:

- RXOUT responds to all valid modulated signals on RXIN, whether from the local transmitter, a remote transmitter, or long noise burst.
- TXOUT responds to TXIN, generating 2.176-MHz signals on TXOUT when TXIN is low, and TXOUT is quiet when TXIN is high. (In normal operation, TXIN is expected to remain high when the device is in receive mode.)
- The device stays in receive mode until 16 bit times after the last rising edge on RXOUT, caused by valid modulated signal on the RXIN line.

When in transmit mode:

- RXOUT stays high, regardless of the input signal on RXIN.
- TXOUT responds to TXIN, generating 2.176-MHz signals on TXOUT when TXIN is low, and TXOUT is quiet when TXIN is high.
- The device stays in transmit mode until 16 bit times after TXIN goes high.

表 8-1 shows the driver functions. 表 8-2 shows the receiver functions. 图 8-1 shows the transitions between each state.

表 8-1. Driver Function Table

TXIN ⁽¹⁾	[DIRSET1, DIRSET2]	TXOUT	COMMENT
H	[L,L], [L,H] or [H,L]	< 1 mV _{PP} at 2.176 MHz	Driver not active
L		V _{OPP} at 2.176 MHz	Driver active
X	[H,H]	< 1 mV _{PP} at 2.176 MHz	Standby mode

(1) H = High, L = Low, X = Indeterminate

表 8-2. Receiver and DIR Function Table

RXIN ⁽¹⁾	RXOUT	DIR	COMMENT (see 图 8-1)
IDLE mode (not transmitting or receiving)			
< V _{IT} at 2.176 MHz for longer than DIR time-out	H	L	No outgoing or incoming signal
RECEIVE mode (not already transmitting)			
< V _{IT} at 2.176 MHz for less than t _{DIR} time-out	H	H	Incoming 1 bit, DIR stays HIGH for DIR time-out
> V _{IT} at 2.176 MHz for longer than t _{noise filter}	L	H	Incoming 0 bit, DIR output is HIGH
TRANSMIT mode (not already receiving)			
X	H	L	Outgoing message, DIR stays LOW for DIR time-out

(1) H = High, L = Low, X = Indeterminate

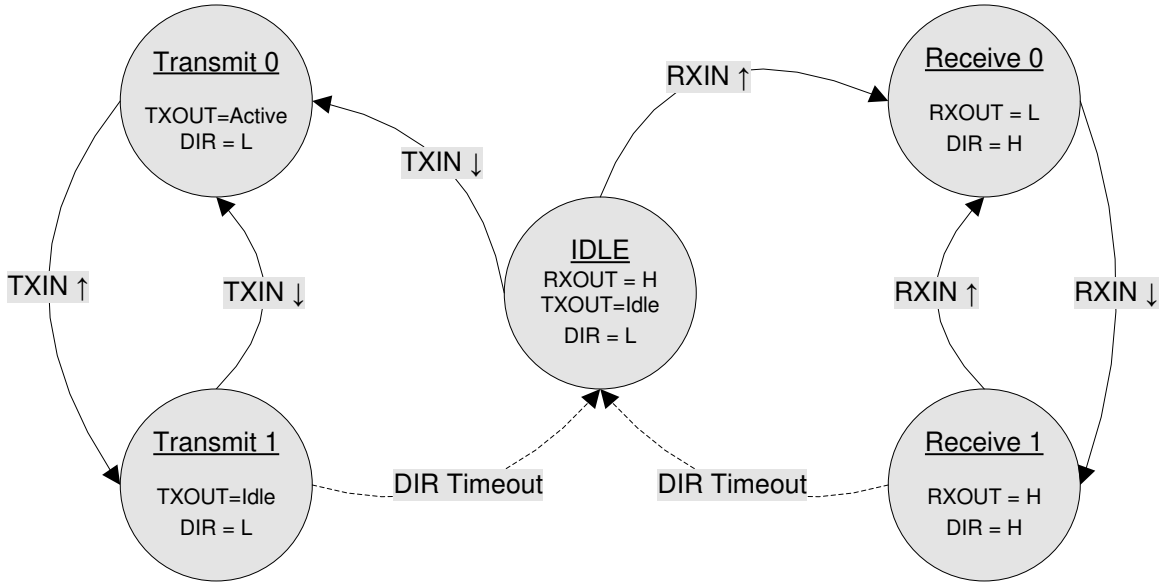

8-1. State Transition Diagram

9 Application and Implementation

Note

Information in the following applications sections is not part of the TI component specification, and TI does not warrant its accuracy or completeness. TI's customers are responsible for determining suitability of components for their purposes. Customers should validate and test their design implementation to confirm system functionality.

9.1 Application Information

9.1.1 Driver Amplitude Adjust

The SN65HVD64 device can provide up to 2.5 V of peak-to-peak output signal at the TXOUT pin to compensate for potential loss within the external filter, cable, connections, and termination. External resistors are used to set the amplitude of the modulated driver output signal. Resistors connected across RES and BIAS set the output amplitude. The maximum peak-to-peak voltage at TXOUT is 2.5 V, corresponding to 6 dBm on the coaxial cable. The TXOUT voltage level can be adjusted by choice of resistors to set the voltage at the RES pin according to [Equation 1](#):

$$V_{TXOUT} (V_{PP}) = (2.5 V_{PP} \times V_{RES} (V)) / 1.5 V \quad V_{RES} (V) = 1.5 V \times R2 / (R1 + R2) \quad V_{TXOUT} (V_{PP}) = 2.5 V_{PP} \times R2 / (R1 + R2) \quad (1)$$

The voltage at the RES pin should be from 0.7 V to 1.5 V. Connect RES directly to the BIAS ($R1 = 0 \Omega$) for maximum output level of 2.5 VPP. This gives a minimum voltage level at TXOUT of 1.2 VPP, corresponding to about 0 dBm at the coaxial cable. A 1- μ F capacitor should be connected between the BIAS pin and GND. To obtain a nominal power level of 3 dBm at the feeder cable as the AISG standard requires, use $R1 = 4.1 \text{ k}\Omega$ and $R2 = 10 \text{ k}\Omega$ that provide 1.78 VPP at TXOUT.

9.1.2 Direction Control

In many applications the mast-top modem that receives data from the base distributes the received data through an RS-485 network to several mast-top devices. When the mast-top modem receives the first logic 0 bit (active modulated signal) it takes control of the mast-top RS-485 network by asserting the direction control signal. The duration of the direction control assertion should be optimized to pass a complete message of length B bits at the known signaling rate ($1/t_{BIT}$) before relinquishing control of the mast-top RS-485 network. For example, if the messages are 10 bits in length ($B=10$) and the signaling rate is 9600 bits per second ($t_{BIT} = 0.104 \text{ ms}$) then a positive pulse of duration 1.7 ms is sufficient (with margin to allow for network propagation delays) to enable the mast-top RS-485 drivers to distribute each received message. [Figure 9-1](#) shows the assertion of direction control.

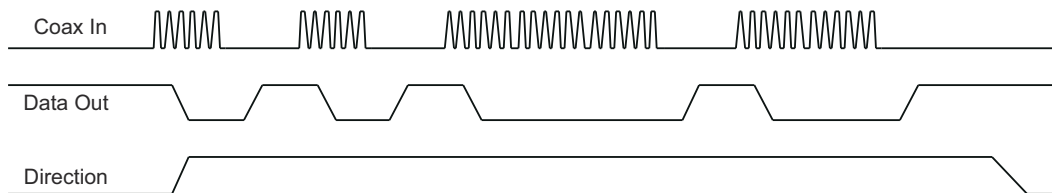

Figure 9-1. Assertion of Direction Control

9.1.3 Direction Control Time Constant

The time constant for the direction control function can be set by the control mode pins, DIRSET1 and DIRSET2. These pins should be set to correspond to the desired data rate. With no external connections to the control mode pins, the internal time constant is set to the maximum value, corresponding to the minimum data rate.

9.1.4 Conversion Between dBm and Peak-to-Peak Voltage

$$\text{dBm} = 20 \times \text{LOG}_{10} [\text{Volts-pp} / \text{SQRT}(0.008 \times Z_o)] = 20 \times \text{LOG}_{10} [V_{PP} / 0.63] \text{ for } Z_o = 50 \Omega \quad (2)$$

$$V_{PP} = \text{SQRT}(0.008 \times Z_o) \times 10^{(\text{dBm}/20)} = 0.63 \times 10^{(\text{dBm}/20)} \text{ for } Z_o = 50 \Omega \quad (3)$$

表 9-1 shows conversions between dBm and peak-to-peak voltage with a 50-Ω load, for various levels of interest including reference levels from the *3GPP TS 25.461 Technical Specification*.

表 9-1. Conversions Between dBm and Peak-to-Peak Voltage

SIGNAL ON COAX	dBm	V _{PP}
Maximum Driver ON Signal	5	1.12
Nominal Driver ON Signal	3	0.89
Minimum Driver ON Signal	1	0.71
AISG Maximum Receiver Threshold	-12	0.16
Nominal Receiver Threshold	-15	0.11
Minimum Receiver Threshold	-18	0.08
Maximum Driver OFF Signal	-40	0.006

9.2 Typical Application

The AISG On-Off Keying (OOK) interface allows for command, control, and diagnostic information to be communicated between a base station and the corresponding tower-mounted antennae. 图 9-2 shows a typical application.



图 9-2. Typical AISG Application

9.2.1 Design Requirements

An AISG transceiver is used to convert between digital logic-level signals and RF signals. The AISG standard requires an RF carrier frequency of 2.176 MHz with 100-ppm accuracy. The output signal of the driver, when active, should be from 1 dBm to 5 dBm. The receiver must be designed such that the input threshold is from -18 dBm to -12 dBm.

9.2.2 Detailed Design Procedure

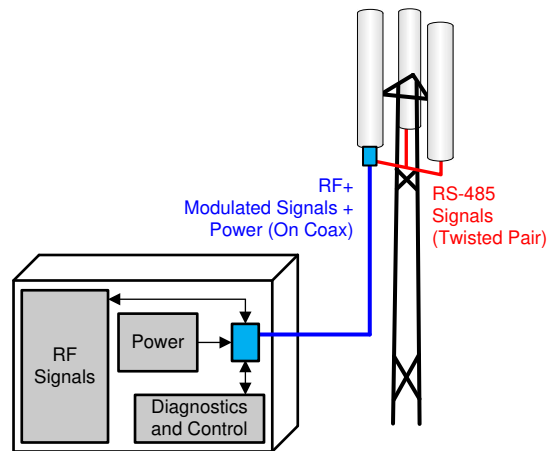
To ensure accuracy of the carrier frequency, an input reference frequency equal to four times the carrier (that is, 8.704 MHz) should be connected to the XTAL1 or XTAL2 inputs. This signal can come from a crystal (connected between XTAL1 and XTAL2) or from a PLL/clock generator circuit (connected to XTAL1 with XTAL2 grounded). The frequency accuracy must be within 100 ppm.

The driver output power level of the SN65HVD64 device can be adjusted through use of the RES pin. To align with AISG requirements, a nominal power level of 3 dBm should be configured by connecting a 4.1-k Ω resistor between RES and BIAS and a 10-k Ω resistor between RES and GND. 9-3 shows an example schematic.

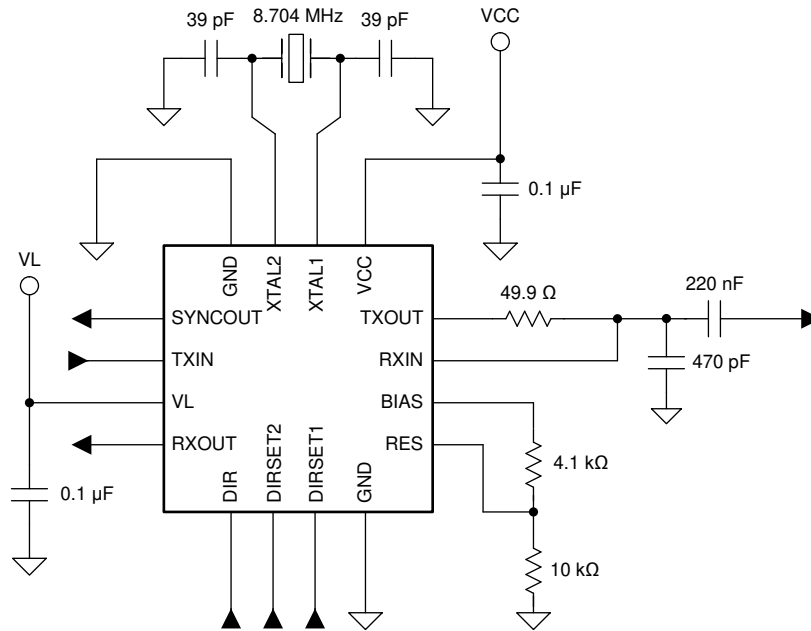

9-3. SN65HVD64 Schematic

9.2.3 Application Curve

9-4 shows the application curve for the SN65HVD64 device.

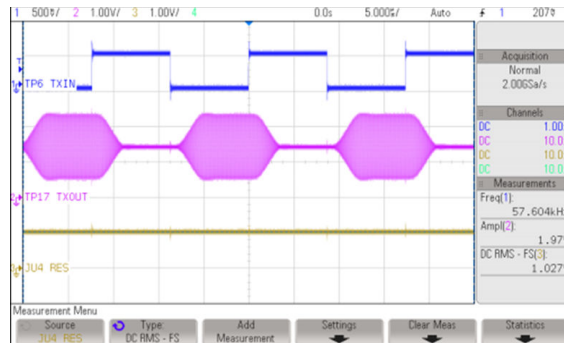

9-4. SN65HVD64 Application Curve

10 Power Supply Recommendations

The SN65HVD64 device has two power supply pins: V_{CC} , which provides power to the analog circuitry, and VL, which is a logic supply. V_{CC} should be operated from 3 V to 5.5 V, while VL can range from 1.6 V to 5.5 V to interface to different logic levels. Power supply decoupling capacitances of at least 0.1 μF should be placed as close as possible to each power supply pin.

11 Layout

11.1 Layout Guidelines

Best practices for high-speed PCB design should be observed because the coax interface to the SN65HVD64 device operates at RF. The RF signaling traces should have a controlled characteristic impedance that is well-matched to the coaxial line. A continuous reference plane should be used to avoid impedance discontinuities. Power and ground distribution should be done through planes rather than traces to decrease series resistance and increase the effective decoupling capacitance on the power rails.

11.2 Layout Example

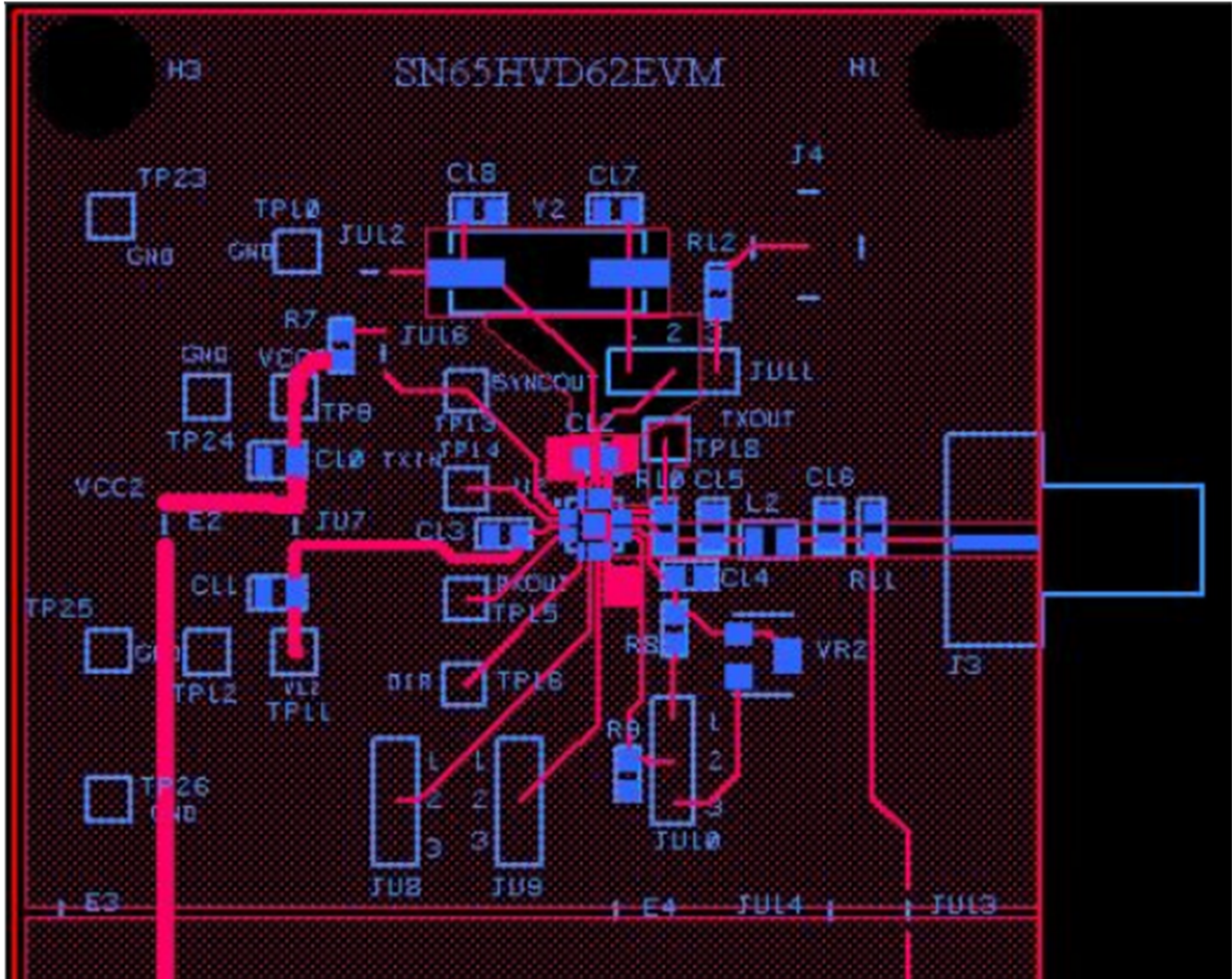

 11-1. SN65HVD64 Layout

12 Device and Documentation Support

TI offers an extensive line of development tools. Tools and software to evaluate the performance of the device, generate code, and develop solutions are listed below.

12.1 Documentation Support

12.1.1 Related Documentation

12.2 Receiving Notification of Documentation Updates

To receive notification of documentation updates, navigate to the device product folder on [ti.com](https://www.ti.com). Click on *Subscribe to updates* to register and receive a weekly digest of any product information that has changed. For change details, review the revision history included in any revised document.

12.3 Support Resources

TI E2E™ [support forums](#) are an engineer's go-to source for fast, verified answers and design help — straight from the experts. Search existing answers or ask your own question to get the quick design help you need.

Linked content is provided "AS IS" by the respective contributors. They do not constitute TI specifications and do not necessarily reflect TI's views; see TI's [Terms of Use](#).

12.4 Trademarks

TI E2E™ is a trademark of Texas Instruments.

AISG® is a registered trademark of Antenna Interface Standards Group, Ltd.

すべての商標は、それぞれの所有者に帰属します。

12.5 Electrostatic Discharge Caution



This integrated circuit can be damaged by ESD. Texas Instruments recommends that all integrated circuits be handled with appropriate precautions. Failure to observe proper handling and installation procedures can cause damage.

ESD damage can range from subtle performance degradation to complete device failure. Precision integrated circuits may be more susceptible to damage because very small parametric changes could cause the device not to meet its published specifications.

12.6 Glossary

[TI Glossary](#) This glossary lists and explains terms, acronyms, and definitions.

Mechanical, Packaging, and Orderable Information

The following pages include mechanical, packaging, and orderable information. This information is the most current data available for the designated devices. This data is subject to change without notice and revision of this document. For browser-based versions of this data sheet, refer to the left-hand navigation.

PACKAGING INFORMATION

Orderable Device	Status (1)	Package Type	Package Drawing	Pins	Package Qty	Eco Plan (2)	Lead finish/ Ball material (6)	MSL Peak Temp (3)	Op Temp (°C)	Device Marking (4/5)	Samples
SN65HVD64RGTR	ACTIVE	VQFN	RGT	16	3000	RoHS & Green	NIPDAU	Level-2-260C-1 YEAR	-40 to 120	HVD64	Samples

(1) The marketing status values are defined as follows:

ACTIVE: Product device recommended for new designs.

LIFEBUY: TI has announced that the device will be discontinued, and a lifetime-buy period is in effect.

NRND: Not recommended for new designs. Device is in production to support existing customers, but TI does not recommend using this part in a new design.

PREVIEW: Device has been announced but is not in production. Samples may or may not be available.

OBSOLETE: TI has discontinued the production of the device.

(2) **RoHS:** TI defines "RoHS" to mean semiconductor products that are compliant with the current EU RoHS requirements for all 10 RoHS substances, including the requirement that RoHS substance do not exceed 0.1% by weight in homogeneous materials. Where designed to be soldered at high temperatures, "RoHS" products are suitable for use in specified lead-free processes. TI may reference these types of products as "Pb-Free".

RoHS Exempt: TI defines "RoHS Exempt" to mean products that contain lead but are compliant with EU RoHS pursuant to a specific EU RoHS exemption.

Green: TI defines "Green" to mean the content of Chlorine (Cl) and Bromine (Br) based flame retardants meet JS709B low halogen requirements of <=1000ppm threshold. Antimony trioxide based flame retardants must also meet the <=1000ppm threshold requirement.

(3) MSL, Peak Temp. - The Moisture Sensitivity Level rating according to the JEDEC industry standard classifications, and peak solder temperature.

(4) There may be additional marking, which relates to the logo, the lot trace code information, or the environmental category on the device.

(5) Multiple Device Markings will be inside parentheses. Only one Device Marking contained in parentheses and separated by a "-" will appear on a device. If a line is indented then it is a continuation of the previous line and the two combined represent the entire Device Marking for that device.

(6) Lead finish/Ball material - Orderable Devices may have multiple material finish options. Finish options are separated by a vertical ruled line. Lead finish/Ball material values may wrap to two lines if the finish value exceeds the maximum column width.

Important Information and Disclaimer:The information provided on this page represents TI's knowledge and belief as of the date that it is provided. TI bases its knowledge and belief on information provided by third parties, and makes no representation or warranty as to the accuracy of such information. Efforts are underway to better integrate information from third parties. TI has taken and continues to take reasonable steps to provide representative and accurate information but may not have conducted destructive testing or chemical analysis on incoming materials and chemicals. TI and TI suppliers consider certain information to be proprietary, and thus CAS numbers and other limited information may not be available for release.

In no event shall TI's liability arising out of such information exceed the total purchase price of the TI part(s) at issue in this document sold by TI to Customer on an annual basis.

RGT 16

GENERIC PACKAGE VIEW

VQFN - 1 mm max height

PLASTIC QUAD FLATPACK - NO LEAD

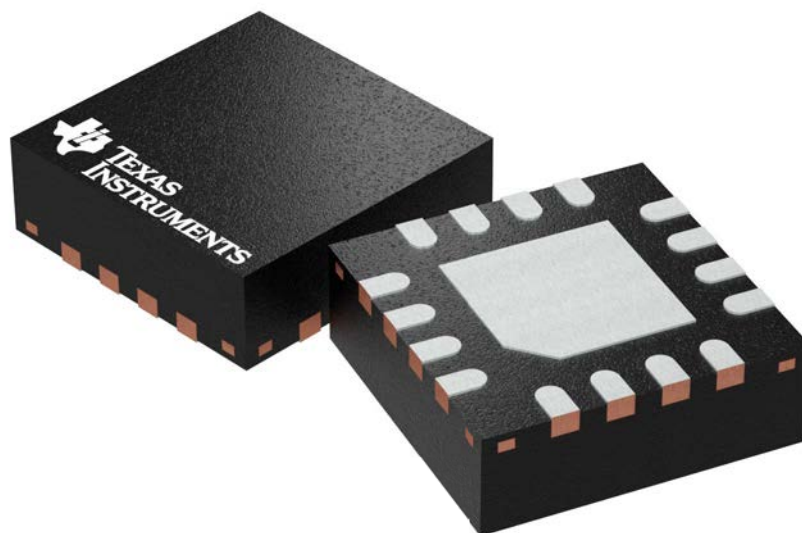

Images above are just a representation of the package family, actual package may vary.
Refer to the product data sheet for package details.

4203495/1

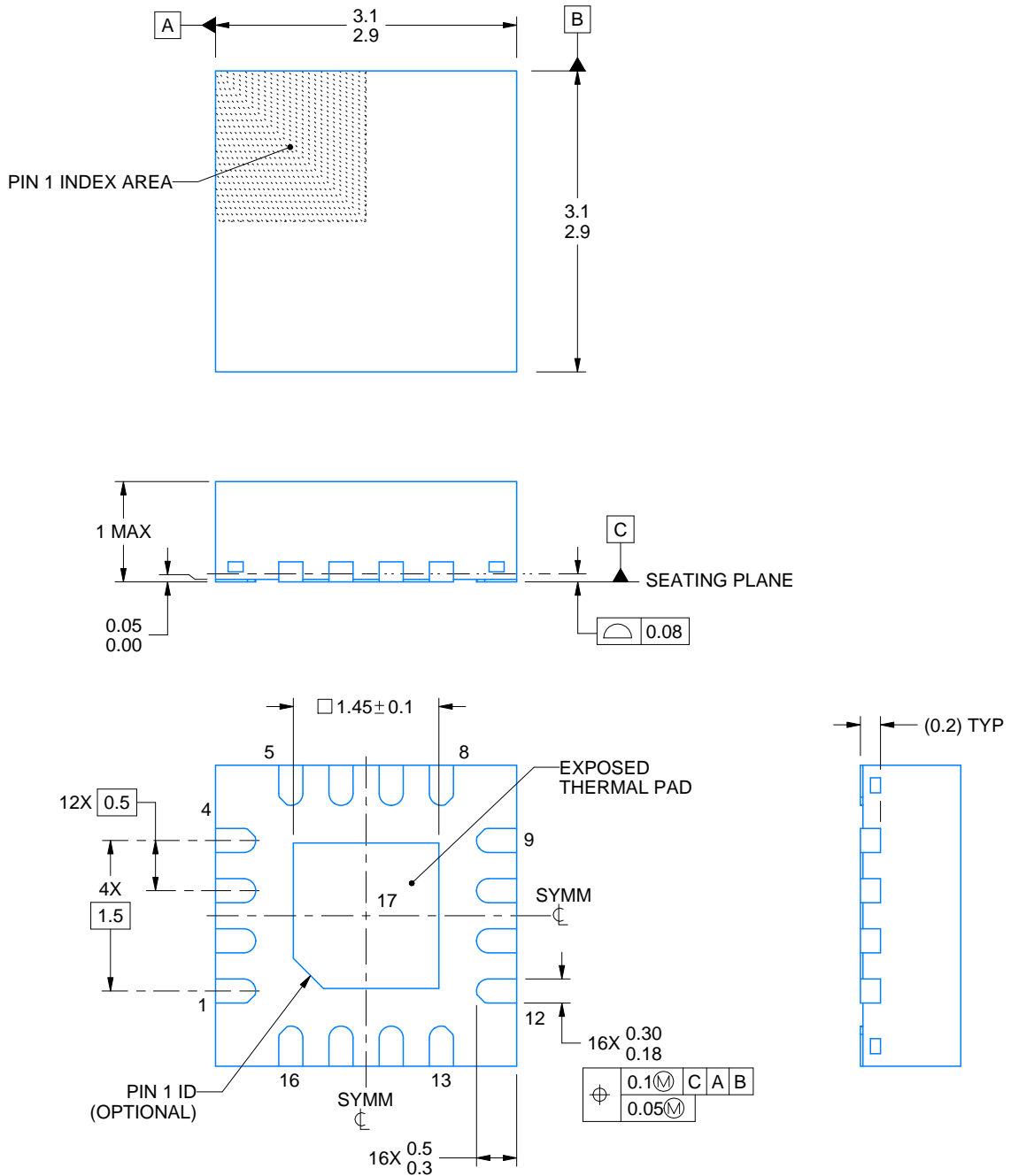
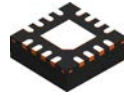

4219032/A 02/2017

NOTES:

1. All linear dimensions are in millimeters. Any dimensions in parenthesis are for reference only. Dimensioning and tolerancing per ASME Y14.5M.
2. This drawing is subject to change without notice.
3. The package thermal pad must be soldered to the printed circuit board for thermal and mechanical performance.
4. Reference JEDEC registration MO-220

EXAMPLE STENCIL DESIGN

RGT0016A

VQFN - 1 mm max height

PLASTIC QUAD FLATPACK - NO LEAD

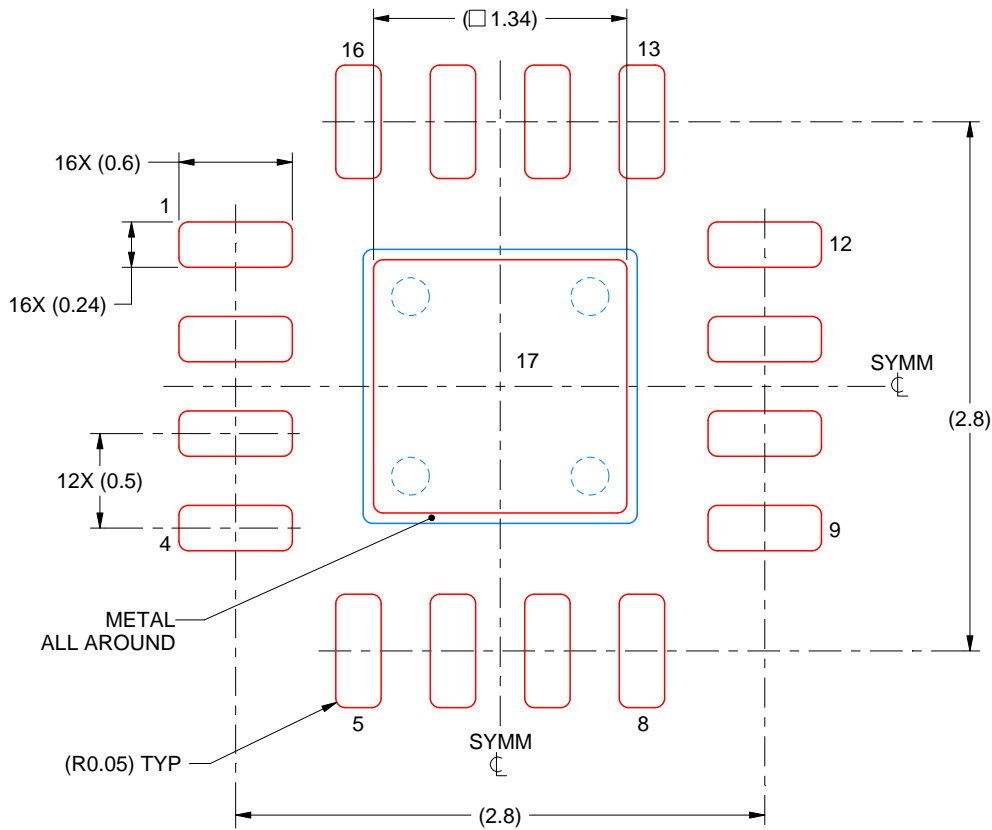

SOLDER PASTE EXAMPLE
BASED ON 0.125 mm THICK STENCIL

EXPOSED PAD 17:
86% PRINTED SOLDER COVERAGE BY AREA UNDER PACKAGE
SCALE:25X

4219032/A 02/2017

NOTES: (continued)

7. Laser cutting apertures with trapezoidal walls and rounded corners may offer better paste release. IPC-7525 may have alternate design recommendations.

重要なお知らせと免責事項

TI は、技術データと信頼性データ (データシートを含みます)、設計リソース (リファレンス・デザインを含みます)、アプリケーションや設計に関する各種アドバイス、Web ツール、安全性情報、その他のリソースを、欠陥が存在する可能性のある「現状のまま」提供しており、商品性および特定目的に対する適合性の黙示保証、第三者の知的財産権の非侵害保証を含むいかなる保証も、明示的または黙示的にかかわらず拒否します。

これらのリソースは、TI 製品を使用する設計の経験を積んだ開発者への提供を意図したものです。(1) お客様のアプリケーションに適した TI 製品の選定、(2) お客様のアプリケーションの設計、検証、試験、(3) お客様のアプリケーションが適用される各種規格や、その他のあらゆる安全性、セキュリティ、またはその他の要件を満たしていることを確実にする責任を、お客様のみが単独で負うものとします。上記の各種リソースは、予告なく変更される可能性があります。これらのリソースは、リソースで説明されている TI 製品を使用するアプリケーションの開発の目的でのみ、TI はその使用をお客様に許諾します。これらのリソースに関して、他の目的で複製することや掲載することは禁止されています。TI や第三者の知的財産権のライセンスが付与されている訳ではありません。お客様は、これらのリソースを自身で使用した結果発生するあらゆる申し立て、損害、費用、損失、責任について、TI およびその代理人を完全に補償するものとし、TI は一切の責任を拒否します。

TI の製品は、TI の販売約款 (<https://www.tij.co.jp/ja-jp/legal/terms-of-sale.html>)、または [ti.com](https://www.ti.com) やかかる TI 製品の関連資料などのいずれかを通じて提供する適用可能な条項の下で提供されています。TI がこれらのリソースを提供することは、適用される TI の保証または他の保証の放棄の拡大や変更を意味するものではありません。

日本語版 日本テキサス・インスツルメンツ合同会社
Copyright © 2021, Texas Instruments Incorporated