

SN65HVDA1040B-Q1 EMC 最適化設計、高速 CAN バス・トランシーバ

1 特長

- 車載アプリケーション向けに AEC-Q100 認証済み
 - 温度グレード 0: $-40^{\circ}\text{C} \sim +125^{\circ}\text{C}$ 、 T_A
 - HBM ESD 分類レベル
 - 3A レベル (ピン 5、6、7 以外のピン)
 - 3B レベル (ピン 5、6、7)
 - CDM ESD 分類レベル C6
- ISO 11898-2/-5 規格の要件に適合 (またはそれを上回る)
- GIFT/ICT に準拠
- バス・ウェイクアップ対応の低電流スタンバイ・モード: 最大 $12\mu\text{A}$
- 高い電磁環境適合性 (EMC)
- SPLIT 電圧源を使用した分割終端によるバス同相安定化
- 3.3V および 5V マイクロプロセッサに対応したデジタル入力
- パッケージ・オプション: SOIC
- 保護機能
 - $-27\text{V} \sim 40\text{V}$ のバス障害保護
 - TXD ドミナント・タイムアウト
 - サーマル・シャットダウン保護機能
 - 電源オン/オフ時のグリッチのないバス入出力
 - 低 V_{CC} 時の高いバス入力インピーダンス (非通電時のバスの受動的挙動として理想的)

2 アプリケーション

- GMW3122 デュアルワイヤ CAN 物理層
- SAE J2284 車載用高速 CAN
- SAE J1939 標準データ・バス・インターフェイス
- ISO 11783 標準データ・バス・インターフェイス
- NMEA 2000 標準データ・バス・インターフェイス

3 概要

SN65HVDA1040B-Q1 は、CAN (Controller Area Network) を使用する用途向けの、ISO 11898 規格に適合する (またはそれを上回る) トランシーバです。CAN トランシーバとして、バスへの差動送信機能と CAN コントローラの差動受信機能を、最大 1 メガビット/秒 (Mbps) の信号レートで実現します。ラインの信号レートとは、1 秒あたりの電圧遷移回数を bps (ビット/秒) 単位で表したものです。

本デバイスは、特に厳しい環境での動作を想定して設計されており、低電圧誤動作防止 (UVLO)、過熱サーマル・シャットダウン、広い同相範囲、グラウンド喪失保護など、多くのデバイス保護機能を搭載しています。また、バス・ピンは外部クロスワイヤ、 $-27\text{V} \sim 40\text{V}$ への短絡、および ISO 7637 に基づく過渡電圧からも保護されます。このデバイスは車載用途向けです。

製品情報(1)

型番	パッケージ	本体サイズ(公称)
SN65HVDA1040B-Q1	SOIC (8)	4.90mmx3.91mm

(1) 提供されているすべてのパッケージについては、巻末の注文情報を参照してください。

ブロック図

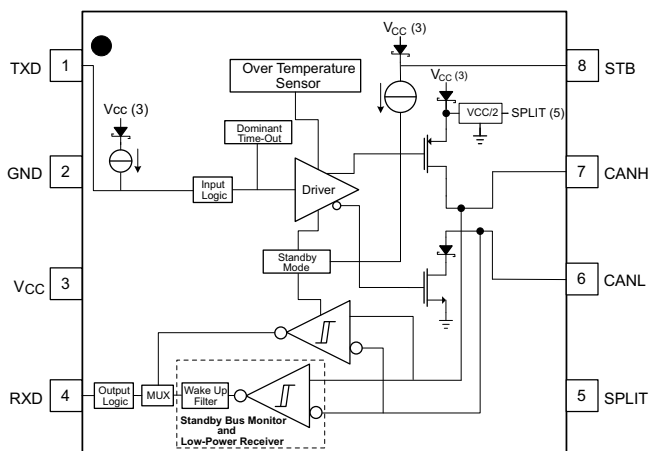

目次

1	特長	1	8.3	Feature Description	13
2	アプリケーション	1	8.4	Device Functional Modes	16
3	概要	1	9	Application and Implementation	17
4	改訂履歴	2	9.1	Application Information	17
5	Pin Configuration and Functions	3	9.2	Typical Application	18
6	Specifications	4	10	Power Supply Recommendations	21
6.1	Absolute Maximum Ratings	4	11	Layout	21
6.2	ESD Ratings	4	11.1	Layout Guidelines	21
6.3	Recommended Operating Conditions	4	11.2	Layout Example	22
6.4	Thermal Information	5	11.3	ESD Protection	22
6.5	Electrical Characteristics	5	12	デバイスおよびドキュメントのサポート	23
6.6	Power Dissipation Characteristics	6	12.1	ドキュメントのサポート	23
6.7	Switching Characteristics	7	12.2	ドキュメントの更新通知を受け取る方法	23
6.8	Typical Characteristics	7	12.3	コミュニティ・リソース	23
7	Parameter Measurement Information	8	12.4	商標	23
8	Detailed Description	13	12.5	静電気放電に関する注意事項	23
8.1	Overview	13	12.6	Glossary	23
8.2	Functional Block Diagram	13	13	メカニカル、パッケージ、および注文情報	23

4 改訂履歴

資料番号末尾の英字は改訂を表しています。その改訂履歴は英語版に準じています。

日付	リビジョン	注
2019年6月	*	初版

5 Pin Configuration and Functions

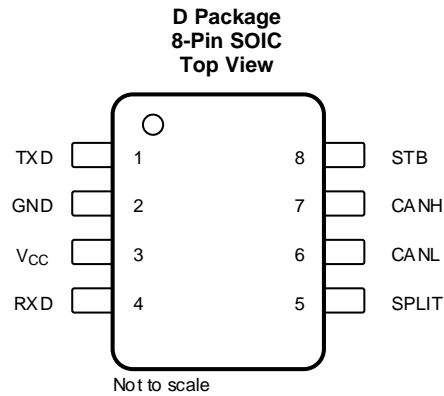

Pin Functions

PIN		TYPE	DESCRIPTION
NAME	SOIC		
TXD	1	I	CAN transmit data input (low for dominant bus state, high for recessive bus state)
GND	2	GND	Ground connection
V _{CC}	3	Supply	Transceiver 5-V supply voltage input
RXD	4	O	CAN receive data output (low in dominant bus state, high in recessive bus state)
SPLIT	5	O	Common-mode stabilization output
CANL	6	I/O	Low-level CAN bus line
CANH	7	I/O	High-level CAN bus line
STB	8	I	Standby mode select pin (active high)
NC	—	NC	No connect

6 Specifications

6.1 Absolute Maximum Ratings

over operating free-air temperature range (unless otherwise noted) ⁽¹⁾

		MIN	MAX	UNIT
V _{CC}	Supply voltage	-0.3	6	V
	Voltage range at bus terminals (CANH, CANL, SPLIT)	-27	40	V
I _O	Receiver output current		20	mA
V _I	Voltage input, ISO 7637 transient pulse ⁽²⁾ (CANH, CANL)	-150	100	V
V _I	Voltage input (TXD, STB)	-0.3	6	V
T _J	Junction temperature	-40	150	°C
T _{stg}	Storage temperature	-40	150	°C

- Stresses beyond those listed under *Absolute Maximum Ratings* may cause permanent damage to the device. These are stress ratings only, which do not imply functional operation of the device at these or any other conditions beyond those indicated under *Recommended Operating Conditions*. Exposure to absolute-maximum-rated conditions for extended periods may affect device reliability.
- Tested in accordance with ISO 7637 test pulses 1, 2, 3a, 3b per IBEE system level test (Pulse 1 = -100 V, Pulse 2 = 100 V, Pulse 3a = -150 V, Pulse 3b = 100 V). If DC may be coupled with ac transients, externally protect the bus pins within the absolute maximum voltage range at any bus terminal. This device has been tested with dc bus shorts to 40 V with leading common-mode chokes. If common-mode chokes are used in the system and the bus lines may be shorted to DC, ensure that the choke type and value in combination with the node termination and shorting voltage either will not create inductive flyback outside of voltage maximum specification or use an external transient-suppression circuit to protect the transceiver from the inductive transients.

6.2 ESD Ratings

		VALUE	UNIT		
V _(ESD)	Electrostatic discharge	Human body model (HBM), per AEC Q100-002 ⁽¹⁾	Pins 7 and 6 ⁽²⁾	±12000	V
			Pin 5 ⁽³⁾	±10000	
			All pins	±4000	
		Charged-device model (CDM), per AEC Q100-011		±1500	
		IEC 61000-4-2 according to IBEE CAN EMC test specification	Pins 7 and 6 connected to pin 2	±7000	

- AEC Q100-002 indicates that HBM stressing shall be in accordance with the ANSI/ESDA/JEDEC JS-001 specification.
- Test method based upon JEDEC Standard 22 Test Method A114F and AEC-Q100-002, CANH and CANL bus pins stressed with respect to each other and GND.
- Test method based upon JEDEC Standard 22 Test Method A114F and AEC-Q100-002, SPLIT pin stressed with respect to GND.

6.3 Recommended Operating Conditions

			MIN	MAX	UNIT
V _{CC}	Supply voltage		4.75	5.25	V
V _I or V _{IC}	Voltage at any bus terminal (separately or common mode)		-12	12	V
V _{IH}	High-level input voltage	TXD, STB	2	5.25	V
V _{IL}	Low-level input voltage	TXD, STB	0	0.8	V
V _{ID}	Differential input voltage		-6	6	V
I _{OH}	High-level output current	Driver	-70		mA
		Receiver (RXD)	-2		
I _{OL}	Low-level output current	Driver		70	mA
		Receiver (RXD)		2	
T _A	Operating free-air temperature range	See Thermal Information	-40	125	°C

6.4 Thermal Information

THERMAL METRIC ⁽¹⁾		SN65HVDA1040B-Q1		
		D (SOIC)	UNIT	
		8 PINS		
R _{θJA}	Junction-to-ambient thermal resistance	Low-K thermal resistance ⁽²⁾	140	°C/W
		High-K thermal resistance ⁽³⁾	112	°C/W
R _{θJC(top)}	Junction-to-case (top) thermal resistance		56	°C/W
R _{θJB}	Junction-to-board thermal resistance		50	°C/W
ψ _{JT}	Junction-to-top characterization parameter		13	°C/W
ψ _{JB}	Junction-to-board characterization parameter		55	°C/W
R _{θJC(bot)}	Junction-to-case (bottom) thermal resistance		–	°C/W

- (1) For more information about traditional and new thermal metrics, see the [Semiconductor and IC Package Thermal Metrics](#) application report.
- (2) The junction-to-ambient thermal resistance under natural convection is obtained in a simulation on a JEDEC-standard, Low-K board, as specified in JESD51-3, in an environment described in JESD51-2a.
- (3) The junction-to-ambient thermal resistance under natural convection is obtained in a simulation on a JEDEC-standard, High-K board, as specified in JESD51-7, in an environment described in JESD51-2a.

6.5 Electrical Characteristics

over recommended operating conditions including operating free-air temperature range (unless otherwise noted)

PARAMETER		TEST CONDITIONS	MIN	TYP ⁽¹⁾	MAX	UNIT		
SUPPLY								
I _{CC}	5-V supply current	Standby mode	STB at V _{CC} , V _I = V _{CC}		6	12	μA	
		Dominant	V _I = 0 V, 60-Ω load, STB at 0 V		50	70	mA	
		Recessive	V _I = V _{CC} , No load, STB at 0 V		6	10		
UV _{VCC}	Undervoltage reset threshold		2.8		4	V		
DRIVER								
V _{O(D)}	Bus output voltage (dominant)	CANH	V _I = 0 V, STB at 0 V, R _L = 60 Ω, See Figure 3 and Figure 16		2.9	3.4	4.5	V
		CANL			0.8		1.75	
V _{O(R)}	Bus output voltage (recessive)		V _I = 3 V, STB at 0 V, R _L = 60 Ω, See Figure 3 and Figure 16		2	2.5	3	V
V _O	Bus output voltage (standby mode)		STB at V _{CC} , R _L = 60 Ω, See Figure 3 and Figure 16		–0.1		0.1	V
V _{OD(D)}	Differential output voltage (dominant)		V _I = 0 V, R _L = 60 Ω, STB at 0 V, See Figure 3 , Figure 16 , and Figure 4		1.5		3	V
			V _I = 0 V, R _L = 45 Ω, STB at 0 V, See Figure 3 , Figure 16 , and Figure 4		1.4		3	
V _{OD(R)}	Differential output voltage (recessive)		V _I = 3 V, STB at 0 V, R _L = 60 Ω, See Figure 3 and Figure 16		–0.012		0.012	V
			V _I = 3 V, STB at 0 V, No load		–0.5		0.05	
V _{SYM}	Output symmetry (dominant or recessive) (V _{O(CANH)} + V _{O(CANL)})		STB at 0 V, R _L = 60 Ω, See Figure 14		0.9 V _{CC}	V _{CC}	1.1 V _{CC}	V
V _{OC(ss)}	Steady-state common-mode output voltage		STB at 0 V, R _L = 60 Ω, See Figure 9		2	2.5	3	V
ΔV _{OC(ss)}	Change in steady-state common-mode output voltage		STB at 0 V, R _L = 60 Ω, See Figure 9			30		mV
V _{IH}	High-level input voltage, TXD input				2			V
V _{IL}	Low-level input voltage, TXD input						0.8	V
I _{IH}	High-level input current, TXD input		V _I at V _{CC}		–2		2	μA
I _{IL}	Low-level input current, TXD input		V _I at 0 V		–50		–10	μA
I _{O(off)}	Power-off TXD output current		V _{CC} at 0 V, TXD at 5 V				1	μA

(1) All typical values are at 25°C with a 5-V supply.

Electrical Characteristics (continued)

over recommended operating conditions including operating free-air temperature range (unless otherwise noted)

PARAMETER	TEST CONDITIONS	MIN	TYP ⁽¹⁾	MAX	UNIT		
$I_{OS(ss)}$	Short-circuit steady-state output current, Dominant	$V_{CANH} = -12\text{ V}$, CANL open, TXD = low, See Figure 12	-120	-85		mA	
		$V_{CANH} = 12\text{ V}$, CANL open, TXD = low, See Figure 12		0.4	1		
		$V_{CANL} = -12\text{ V}$, CANH open, TXD = low, See Figure 12	-1	-0.6			
		$V_{CANL} = 12\text{ V}$, CANH open, TXD = low, See Figure 12		75	120		
		$V_{CANH} = 0\text{ V}$, CANL open, TXD = low, See Figure 12	-100	-75			
		$V_{CANL} = 32\text{ V}$, CANH open, TXD = low, See Figure 12		75	125		
$I_{OS(ss)}$	Short-circuit steady-state output current, Recessive	$-20\text{ V} \leq V_{CANH} \leq 32\text{ V}$, CANL open, TXD = high, See Figure 12	-10		10	mA	
		$-20\text{ V} \leq V_{CANL} \leq 32\text{ V}$, CANH open, TXD = high, See Figure 12	-10		10		
C_O	Output capacitance	See receiver input capacitance					
RECEIVER							
V_{IT+}	Positive-going input threshold voltage, high-speed mode	STB at 0 V, See Table 1		800	900	mV	
V_{IT-}	Negative-going input threshold voltage, high-speed mode	STB at 0 V, See Table 1		500	650	mV	
V_{hys}	Hysteresis voltage ($V_{IT+} - V_{IT-}$)			100	125	mV	
V_{IT}	Input threshold voltage, standby mode	STB at V_{CC}		500	1150	mV	
V_{OH}	High-level output voltage	$I_O = -2\text{ mA}$, See Figure 7		4	4.6	V	
V_{OL}	Low-level output voltage	$I_O = 2\text{ mA}$, See Figure 7		0.2	0.4	V	
$I_{I(off)}$	Power-off bus input current (unpowered bus leakage current)	CANH = CANL = 5 V, V_{CC} at 0 V, TXD at 0 V			3	μA	
$I_{O(off)}$	Power-off RXD leakage current	V_{CC} at 0 V, RXD at 5 V			20	μA	
C_I	Input capacitance to ground (CANH or CANL)	TXD at 3 V, $V_I = 0.4 \sin(4E6\pi t) + 2.5\text{ V}$		13		pF	
C_{ID}	Differential input capacitance	TXD at 3 V, $V_I = 0.4 \sin(4E6\pi t)$		6		pF	
R_{ID}	Differential input resistance	TXD at 3 V, STB at 0 V		30	80	k Ω	
R_{IN}	Input resistance (CANH or CANL)	TXD at 3 V, STB at 0 V		15	30	40	k Ω
$R_{I(m)}$	Input resistance matching $[1 - (R_{IN(CANH)} / R_{IN(CANL)})] \times 100\%$	$V_{(CANH)} = V_{(CANL)}$		-3%	0%	3%	
STB PIN							
V_{IH}	High-level input voltage, STB input			2		V	
V_{IL}	Low-level input voltage, STB input				0.8	V	
I_{IH}	High-level input current	STB at 2 V		-10	0	μA	
I_{IL}	Low-level input current	STB at 0.8 V		-10	0	μA	
SPLIT PIN							
V_O	Output voltage	$-250\text{ }\mu\text{A} < I_O < 250\text{ }\mu\text{A}$	$0.3 V_{CC}$	$0.5 V_{CC}$	$0.7 V_{CC}$	V	
$I_{O(stb)}$	Leakage current, standby mode	STB at 2 V, $-12\text{ V} \leq V_O \leq 12\text{ V}$		-5	5	μA	

6.6 Power Dissipation Characteristics

 over recommended operating conditions, $T_A = -40^\circ\text{C}$ to 125°C (unless otherwise noted)

PARAMETER	TEST CONDITIONS	MIN	TYP	MAX	UNIT	
P_D	Average power dissipation	$V_{CC} = 5\text{ V}$, $T_J = 27^\circ\text{C}$, $R_L = 60\text{ }\Omega$, STB at 0 V, Input to TXD at 500 kHz, 50% duty cycle square wave, C_L at RXD = 15 pF		112		mW
		$V_{CC} = 5.5\text{ V}$, $T_J = 130^\circ\text{C}$, $R_L = 45\text{ }\Omega$, STB at 0 V, Input to TXD at 500 kHz, 50% duty cycle square wave, C_L at RXD = 15 pF			170	
	Thermal shutdown temperature		185		$^\circ\text{C}$	

6.7 Switching Characteristics

over operating free-air temperature range (unless otherwise noted)

PARAMETER		TEST CONDITIONS	MIN	TYP	MAX	UNIT
DEVICE SWITCHING CHARACTERISTICS						
$t_{d(LOOP1)}$	Total loop delay, driver input to receiver output, recessive to dominant	STB at 0 V, See Figure 10	90		230	ns
$t_{d(LOOP2)}$	Total loop delay, driver input to receiver output, dominant to recessive	STB at 0 V, See Figure 10	90		230	ns
DRIVER SWITCHING CHARACTERISTICS						
t_{PLH}	Propagation delay time, low-to-high level output	STB at 0 V, See Figure 5	25	65	120	ns
t_{PHL}	Propagation delay time, high-to-low level output	STB at 0 V, See Figure 5	25	45	120	ns
t_r	Differential output signal rise time	STB at 0 V, See Figure 5		25		ns
t_f	Differential output signal fall time	STB at 0 V, See Figure 5		45		ns
t_{en}	Enable time from standby mode to normal mode and transmission of dominant	See Figure 8			10	μ s
$t_{(dom)}$	Dominant time-out ⁽¹⁾	$\downarrow V_I$, See Figure 11	300	450	700	μ s
RECEIVER SWITCHING CHARACTERISTICS						
t_{PLH}	Propagation delay time, low-to-high-level output	STB at 0 V, See Figure 7	60	90	130	ns
t_{PHL}	Propagation delay time, high-to-low-level output	STB at 0 V, See Figure 7	45	70	130	ns
t_r	Output signal rise time	STB at 0 V, See Figure 7		8		ns
t_f	Output signal fall time	STB at 0 V, See Figure 7		8		ns
t_{BUS}	Dominant time required on bus for wakeup from standby	STB at V_{CC} . See Figure 13	1		5	μ s

- (1) The TXD dominant time-out ($t_{(dom)}$) disables the driver of the transceiver once the TXD has been dominant longer than $t_{(dom)}$, which releases the bus lines to recessive, preventing a local failure from locking the bus dominant. The driver may only transmit dominant again after TXD has been returned HIGH (recessive). While this protects the bus from local faults, locking the bus dominant, it limits the minimum data rate possible. The CAN protocol allows a maximum of eleven successive dominant bits (on TXD) for the worst case, where 5 successive dominant bits are followed immediately by an error frame. This, along with the $t_{(dom)}$ minimum, limits the minimum bit rate. The minimum bit rate may be calculated by:

$$\text{Minimum Bit Rate} = 11 / t_{(dom)} = 11 \text{ bits} / 300 \mu\text{s} = 37 \text{ kbps}$$

6.8 Typical Characteristics

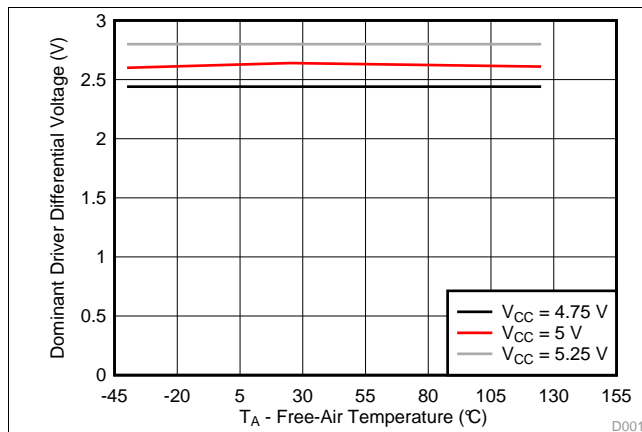

Figure 1. Dominant Driver Differential Voltage vs Free-Air Temperature

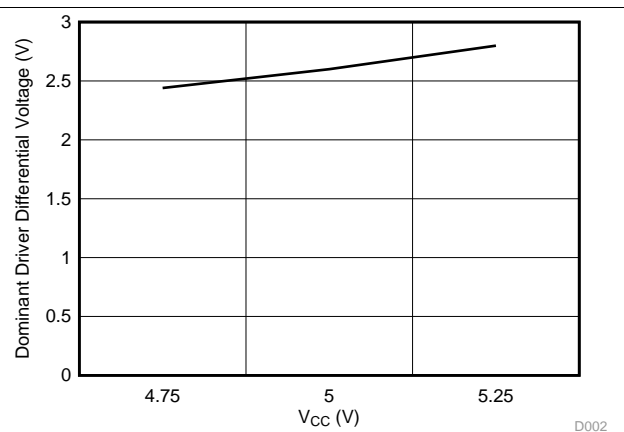

Figure 2. Driver Differential Voltage vs. Supply Voltage

7 Parameter Measurement Information

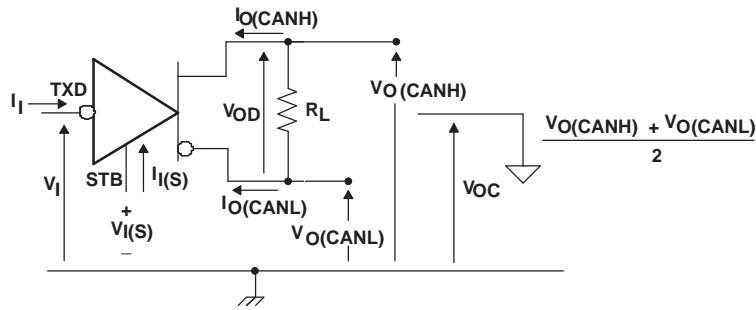

Figure 3. Driver Voltage, Current, and Test Definition

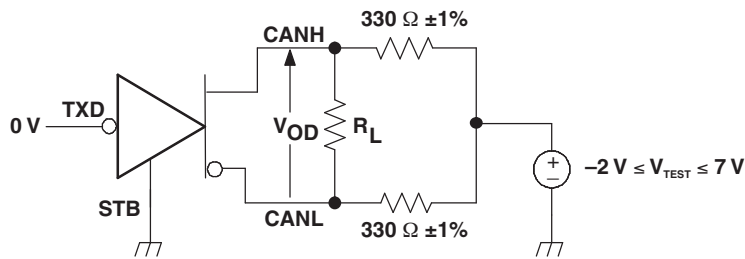

Figure 4. Driver V_{OD} Test Circuit

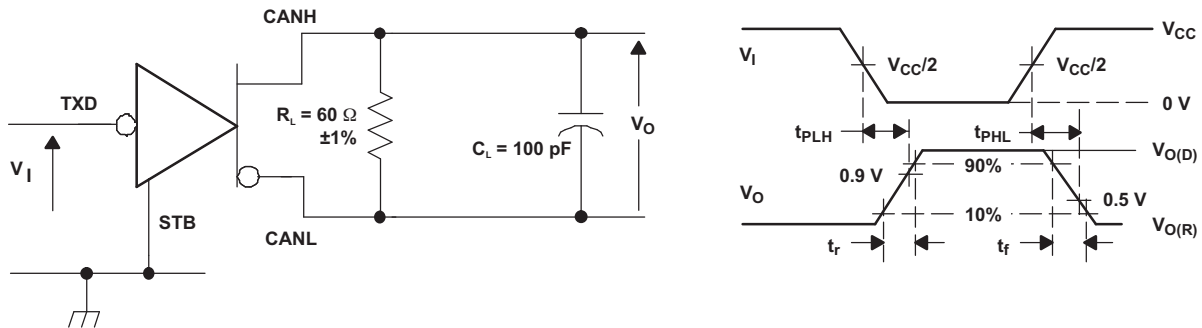

Figure 5. Driver Test Circuit and Voltage Waveforms

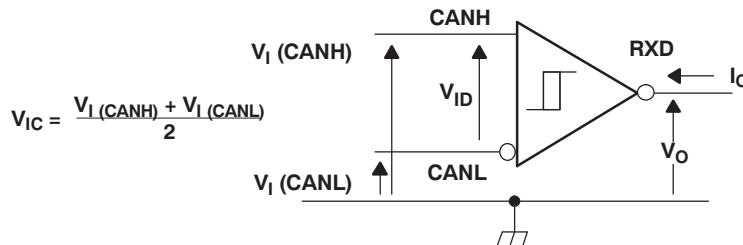
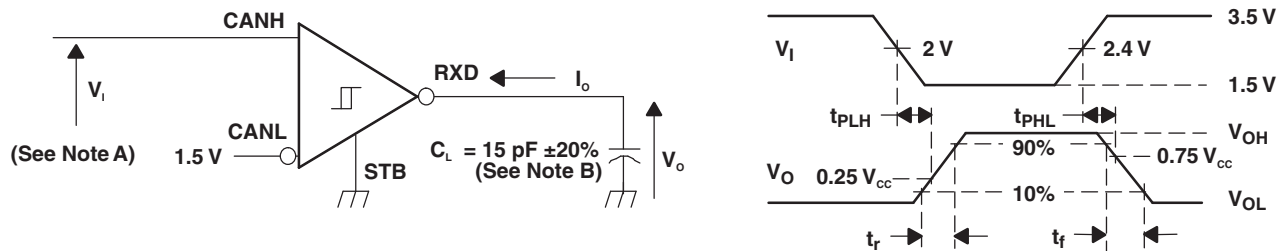

Figure 6. Receiver Voltage and Current Definitions

Parameter Measurement Information (continued)



- A. The input pulse is supplied by a generator having the following characteristics: PRR ≤ 125 kHz, 50% duty cycle, $t_r \leq 6$ ns, $t_f \leq 6$ ns, $Z_O = 50 \Omega$.
- B. C_L includes instrumentation and fixture capacitance within $\pm 20\%$.

Figure 7. Receiver Test Circuit and Voltage Waveforms

Table 1. Differential Input Voltage Threshold Test

INPUT			OUTPUT R
V _{CANH}	V _{CANL}	V _{ID}	
-11.1 V	-12 V	900 mV	L
12 V	11.1 V	900 mV	L
-6 V	-12 V	6 V	L
12 V	6 V	6 V	L
-11.5 V	-12 V	500 mV	H
12 V	11.5 V	500 mV	H
-12 V	-6 V	6 V	H
6 V	12 V	6 V	H
Open	Open	X	H

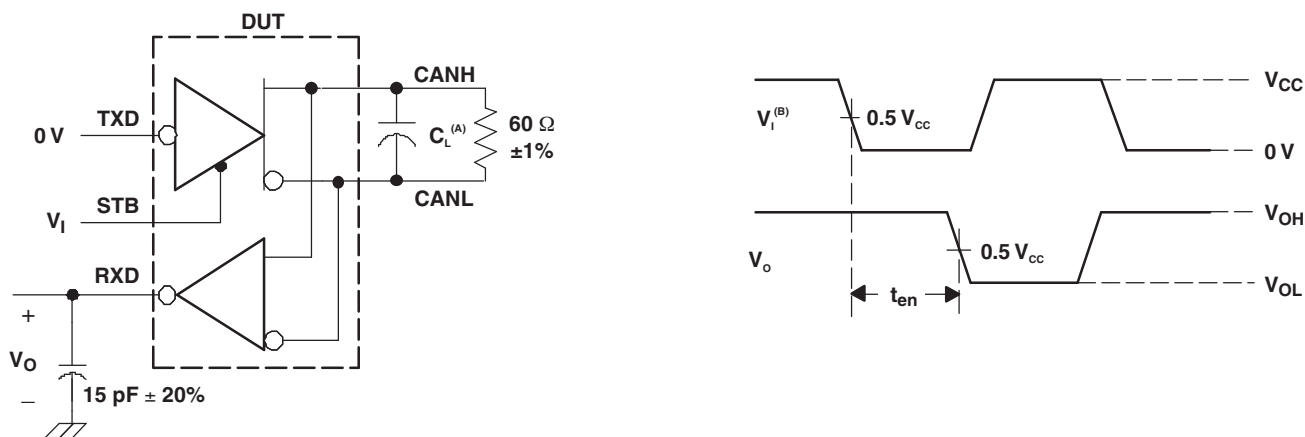

- A. $C_L = 100$ pF and includes instrumentation and fixture capacitance within $\pm 20\%$.
- B. All V_I input pulses are supplied by a generator having the following characteristics: t_r or $t_f \leq 6$ ns, pulse repetition rate (PRR) = 125 kHz, 50% duty cycle.

Figure 8. t_{en} Test Circuit and Waveforms

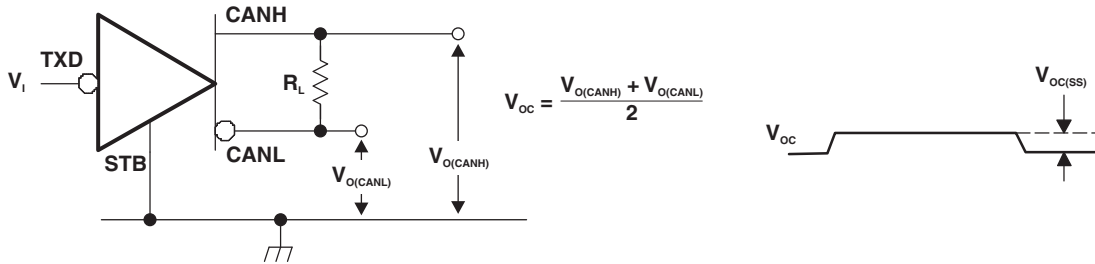

NOTE: All V_I input pulses are from 0 V to V_{CC} and supplied by a generator having the following characteristics: t_r or $t_f \leq 6$ ns, pulse repetition rate (PRR) = 125 kHz, 50% duty cycle.

Figure 9. Common-Mode Output Voltage Test and Waveforms

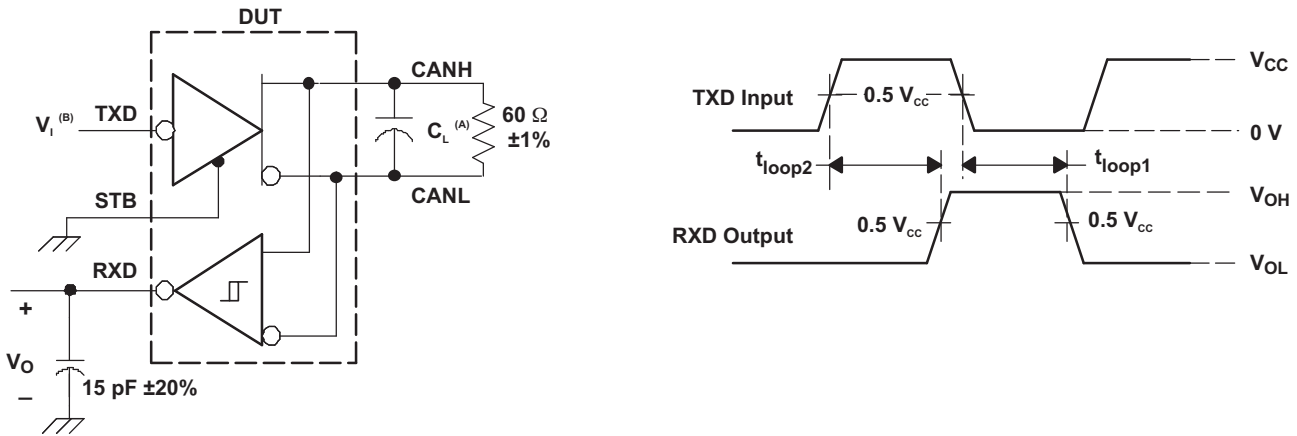

- A. $C_L = 100$ pF and includes instrumentation and fixture capacitance within $\pm 20\%$.
- B. All V_I input pulses are from 0 V to V_{CC} and supplied by a generator having the following characteristics: t_r or $t_f \leq 6$ ns, pulse repetition rate (PRR) = 125 kHz, 50% duty cycle.

Figure 10. $t_{(LOOP)}$ Test Circuit and Waveforms

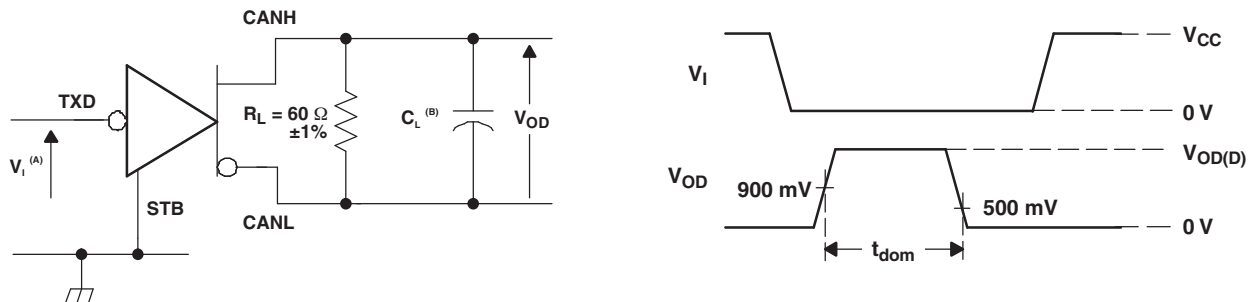

- A. All V_I input pulses are from 0 V to V_{CC} and supplied by a generator having the following characteristics: t_r or $t_f \leq 6$ ns, pulse repetition rate (PRR) = 500 Hz, 50% duty cycle.
- B. $C_L = 100$ pF includes instrumentation and fixture capacitance within $\pm 20\%$.

Figure 11. Dominant Time-Out Test Circuit and Waveforms

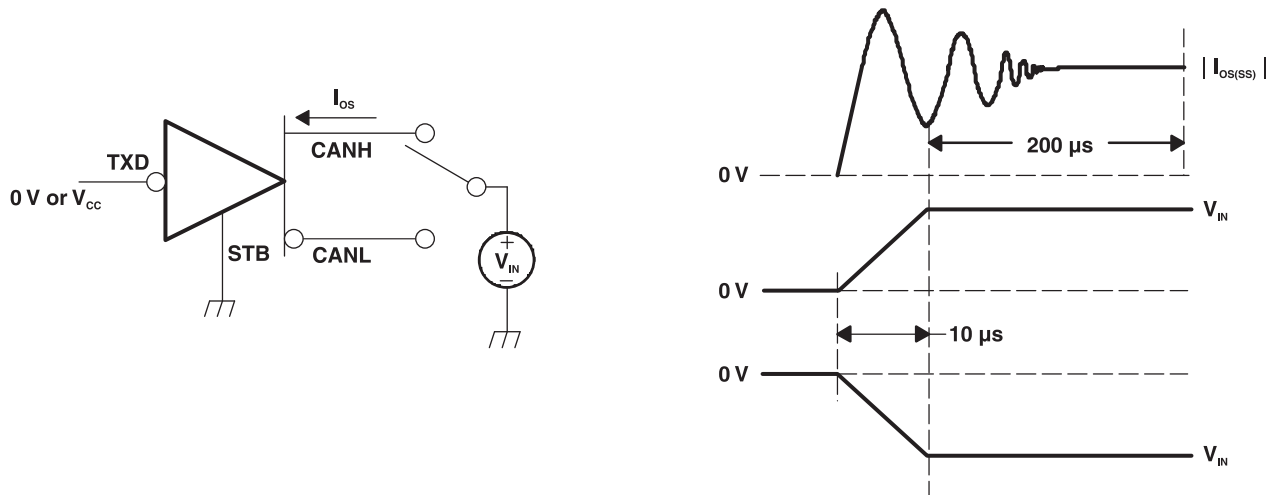
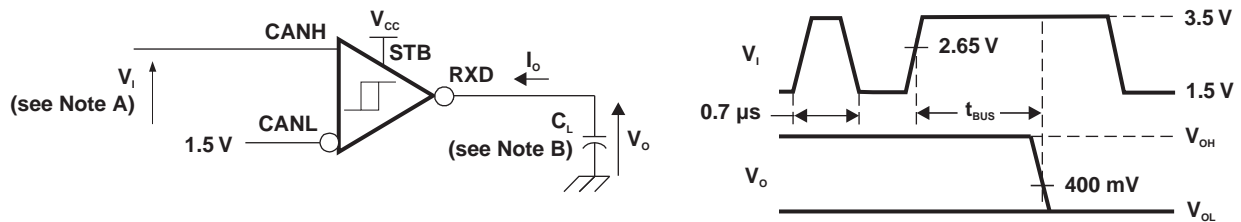
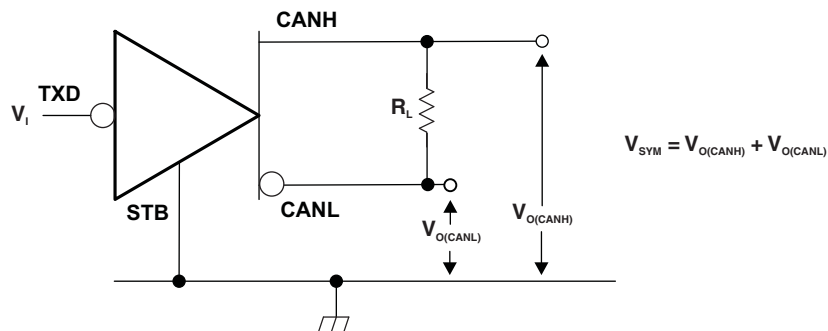

Figure 12. Driver Short-Circuit Current Test and Waveforms



- A. For V_I bit width $\leq 0.7 \mu\text{s}$, $V_O = V_{OH}$. For V_I bit width $\geq 5 \mu\text{s}$, $V_O = V_{OL}$. V_I input pulses are supplied from a generator with the following characteristics: $t_r/t_f < 6 \text{ ns}$.
- B. $C_L = 15 \text{ pF}$ and includes instrumentation and fixture capacitance within $\pm 20\%$.

Figure 13. t_{BUS} Test Circuit and Waveforms



- A. All V_I input pulses are from 0 V to V_{CC} and supplied by a generator having the following characteristics: $t_r/t_f \leq 6 \text{ ns}$, pulse repetition rate (PRR) = 250 kHz , 50% duty cycle.

Figure 14. Driver Output Symmetry Test Circuit

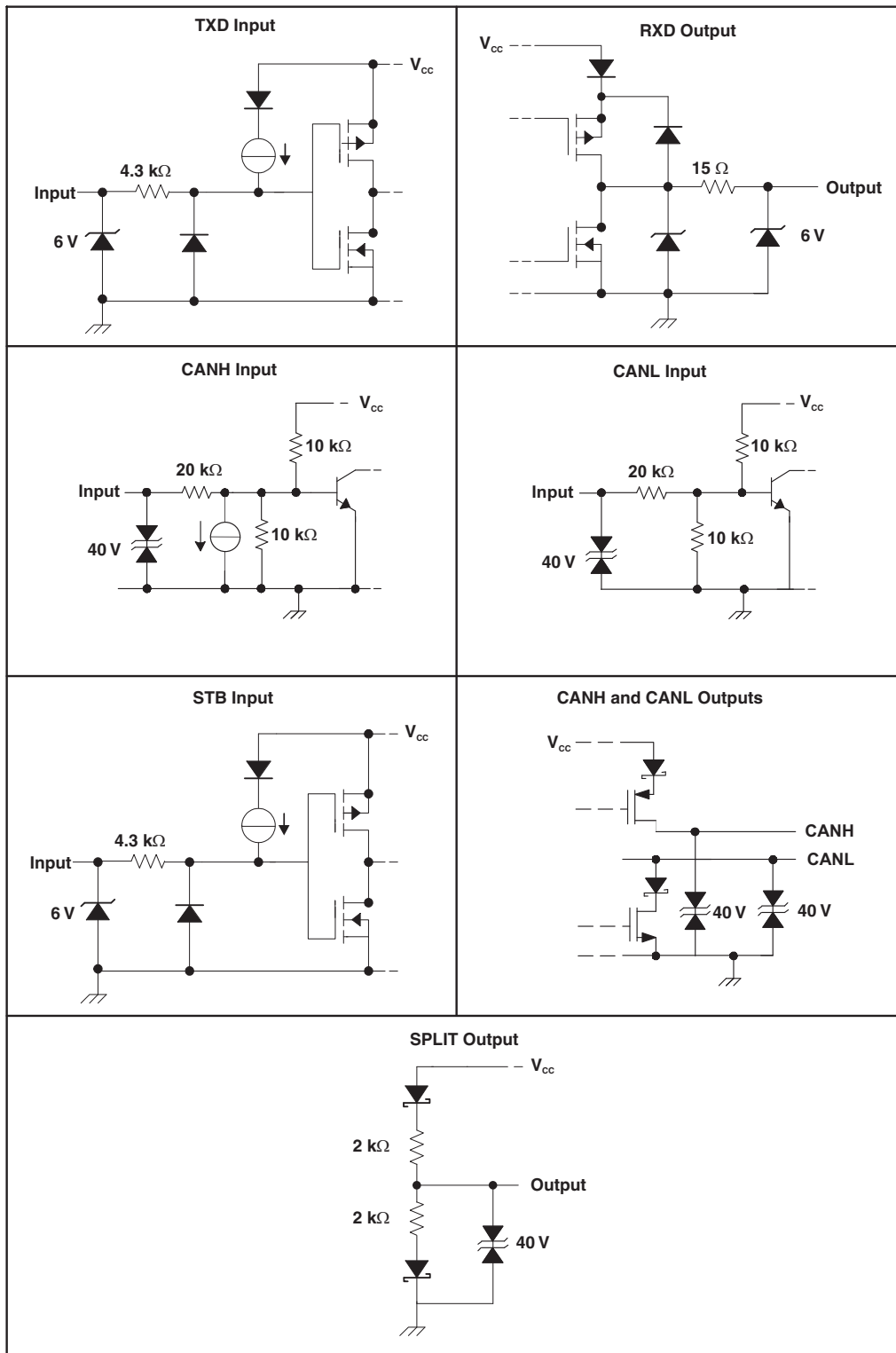

Figure 15. Equivalent Input and Output Schematic Diagrams

8 Detailed Description

8.1 Overview

The SN65HVDA1040B-Q1 CAN transceiver is compatible with the ISO 11898-2 high-speed CAN (Controller Area Network) physical layer standard. The device is designed to interface between the differential bus lines in controller area network and the CAN protocol controller at data rates up to 1 Mbps.

8.2 Functional Block Diagram

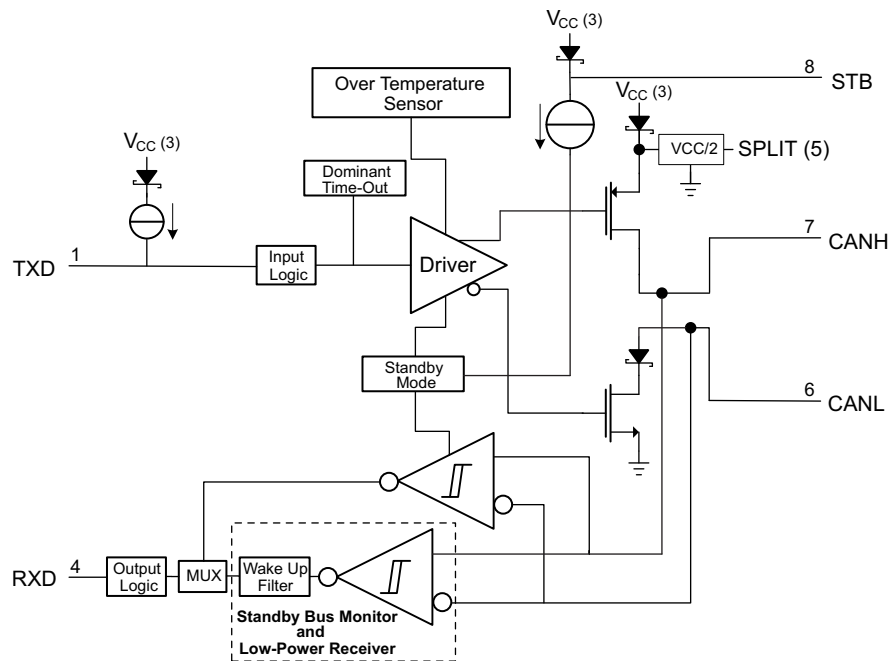

8.3 Feature Description

8.3.1 Operating Modes

The device has two main operating modes: normal mode and standby mode. Operating mode selection is made through the STB input pin.

Table 2. Operating Modes

STB PIN	MODE	DRIVER	RECEIVER	RXD PIN
LOW	NORMAL	Enabled (On)	Enabled (On)	Mirrors CAN bus
HIGH	STANDBY	Disabled (Off)	Low-power wake-up receiver and bus monitor enabled (On)	Low = wake-up request received High = no wake-up request received

8.3.1.1 Bus States by Mode

The CAN bus has three valid states during powered operation depending on the mode of the device. In normal mode the bus may be dominant (logic low) where the bus lines are driven differentially apart or recessive (logic high) where the bus lines are biased to $V_{CC}/2$ through the high-ohmic internal input resistors R_{IN} of the receiver. The third state is low-power standby mode where the bus lines is biased to GND through the high-ohmic internal input resistors R_{IN} of the receiver.

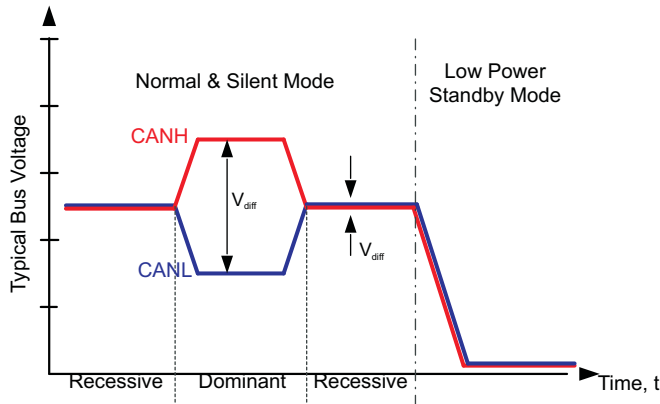

Figure 16. Bus States (Physical Bit Representation)

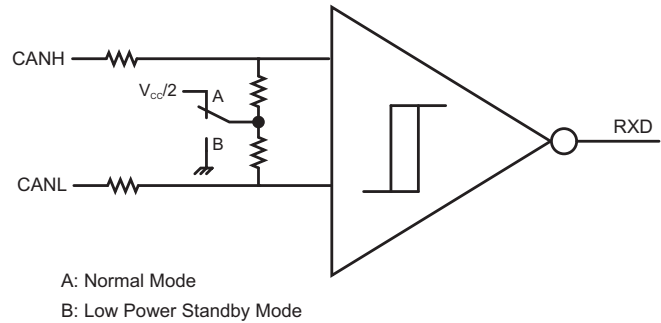

Figure 17. Simplified Common-Mode Bias and Receiver Implementation

8.3.1.2 Normal Mode

This is the normal operating mode of the device. It is selected by setting STB low. The CAN driver and receiver are fully operational and CAN communication is bidirectional. The driver is translating a digital input on TXD to a differential output on CANH and CANL. The receiver is translating the differential signal from CANH and CANL to a digital output on RXD. In recessive state the bus pins are biased to $0.5 \times V_{CC}$. In dominant state the bus pins (CANH and CANL) are driven differentially apart. Logic high is equivalent to recessive on the bus and logic low is equivalent to a dominant (differential) signal on the bus.

The SPLIT pin is biased to $0.5 \times V_{CC}$ for bus common-mode bus voltage bias stabilization in split termination network applications (see [Application and Implementation](#)).

8.3.1.3 Standby Mode and RXD Wake-Up Request

This is the low-power mode of the device. It is selected by setting STB high. The CAN driver and main receiver are turned off and bidirectional CAN communication is not possible. The low-power receiver and bus monitor are enabled to allow for wake-up requests through the bus. A wake-up request is output to RXD (driven low) for any dominant bus transmissions longer than the filter time t_{BUS} . The local protocol controller (MCU) should monitor RXD for transitions and then reactivate the device to normal mode based on the wake-up request. The CAN bus pins are weakly pulled to GND and the SPLIT pin is off (floating).

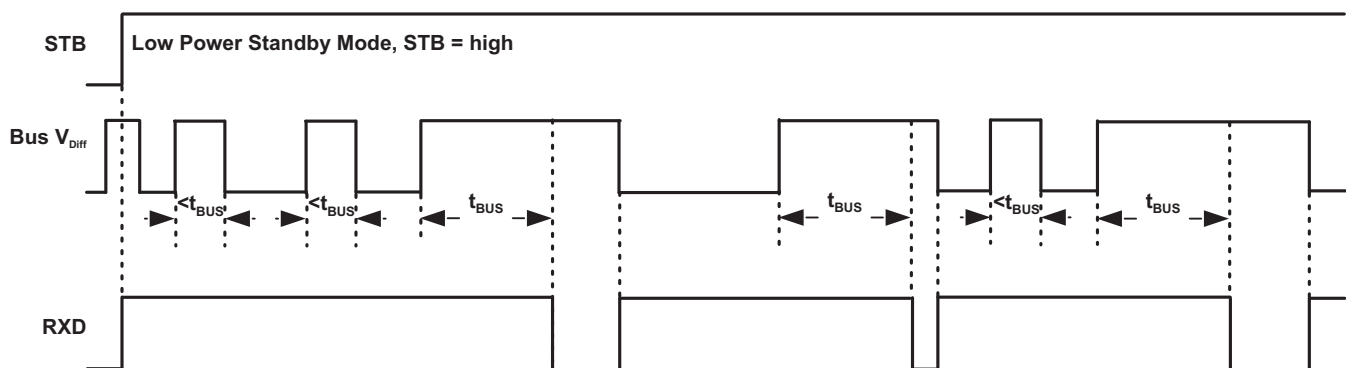

Figure 18. Standby Mode Low-Power Receiver and Bus Monitor Behavior

8.3.2 Protection Features

8.3.2.1 TXD Dominant State Time-Out

During normal mode (the only mode in which the CAN driver is active) the TXD dominant time-out circuit prevents the transceiver from blocking network communication in event of a hardware or software failure where TXD is held dominant longer than the time-out period t_{DST} . The dominant time-out circuit is triggered by a falling edge on TXD. If no rising edge is seen before the time-out constant of the circuit expires (t_{DST}), the CAN bus driver is disabled, thus freeing the bus for communication between other network nodes. The CAN driver is re-activated when a recessive signal is seen on the TXD pin, thus clearing the dominant state time-out. The CAN bus pins are biased to recessive level during a TXD dominant state time-out and SPLIT remains on.

NOTE

The maximum dominant TXD time allowed by the TXD Dominant state time-out limits the minimum possible data rate of the device. The CAN protocol allows a maximum of 11 successive dominant bits (on TXD) for the worst case, where 5 successive dominant bits are followed immediately by an error frame. This, along with the $t_{(dom)}$ minimum, limits the minimum bit rate. The minimum bit rate may be calculated by: Minimum Bit Rate = $11/t_{(dom)}$

8.3.2.2 Thermal Shutdown

If the junction temperature of the device exceeds the thermal shutdown threshold the device turns off the CAN driver circuits, including the SPLIT pin. This condition is cleared when the temperature drops below the thermal shutdown temperature of the device.

8.3.2.3 Undervoltage Lockout and Unpowered Device

The device has undervoltage detection and lockout on the V_{CC} supply. If an undervoltage condition is detected on V_{CC} , the device protects the bus.

The TXD pin is pulled up to V_{CC} to force a recessive input level if the pin floats. The STB is pulled up to V_{CC} to force the device in standby mode (low power) if the pin floats.

The bus pins (CANH, CANL, and SPLIT) all have extremely low leakage currents when the device is unpowered, so it does not load down the bus, but be an *ideal passive* load to the bus. This is critical, especially if some nodes of the network are unpowered while the rest of the network remains in operation.

8.4 Device Functional Modes

Table 3. Driver Function Table⁽¹⁾

INPUTS		OUTPUTS		BUS STATE
TXD	STB	CANH	CANL	
L	L	H	L	Dominant
H	L	Z	Z	Recessive
Open	L	Z	Z	Recessive
X	H or Open	Y	Y	Recessive

(1) H = high level, L = low level, X = irrelevant, Y = weak pulldown to GND, ? = indeterminate, Z = high impedance

Table 4. Receiver Function Table

DIFFERENTIAL INPUTS $V_{ID} = V(\text{CANH}) - V(\text{CANL})$	STB	OUTPUT RXD	BUS STATE
$V_{ID} \geq 0.9 \text{ V}$	L	L	Dominant
$V_{ID} \geq 1.15 \text{ V}$	H or Open	L	Dominant
$0.5 \text{ V} < V_{ID} < 0.9 \text{ V}$	X	?	?
$V_{ID} \leq 0.5 \text{ V}$	X	H	Recessive
Open	X	H	Recessive

9 Application and Implementation

NOTE

Information in the following applications sections is not part of the TI component specification, and TI does not warrant its accuracy or completeness. TI's customers are responsible for determining suitability of components for their purposes. Customers should validate and test their design implementation to confirm system functionality.

9.1 Application Information

9.1.1 Using With 3.3-V Microcontrollers

The input level threshold for the digital input pins of this device are 3.3-V compatible, however a few application considerations must be taken if using this device with 3.3-V microcontrollers. Both TXD and STB input pins have internal pullup sources to V_{CC} . Some microcontroller vendors recommend using an open-drain configuration on their I/O pins in this case even though the pullup limits the current. As such care must be taken at the application level that TXD and STB have sufficient pullup to meet system timing requirements for CAN. The internal pullup on TXD especially may not be sufficient to overcome the parasitic capacitances and allow for adequate CAN timing; thus, an additional external pullup may be required. Care should also be taken with the RXD pin of the microcontroller as the RXD output of this device drives the full V_{CC} range (5 V). If the microcontroller RXD input pin is not 5-V tolerant, this must be addressed at the application level. Other options include using a CAN transceiver from TI with I/O level adapting or a 3.3-V CAN transceiver.

9.1.2 Using SPLIT With Split Termination

The SPLIT pin voltage output provides $0.5 \times V_{CC}$ in normal mode. The circuit may be used by the application to stabilize the common-mode voltage of the bus by connecting it to the center tap of split termination for the CAN network (see [Figure 19](#) and [Figure 20](#)). This pin provides a stabilizing recessive voltage drive to offset leakage currents of unpowered transceivers or other bias imbalances that might bring the network common-mode voltage away from $0.5 \times V_{CC}$. Using this feature in a CAN network improves electromagnetic emissions behavior of the network by eliminating fluctuations in the bus common-mode voltage levels at the start of message transmissions.

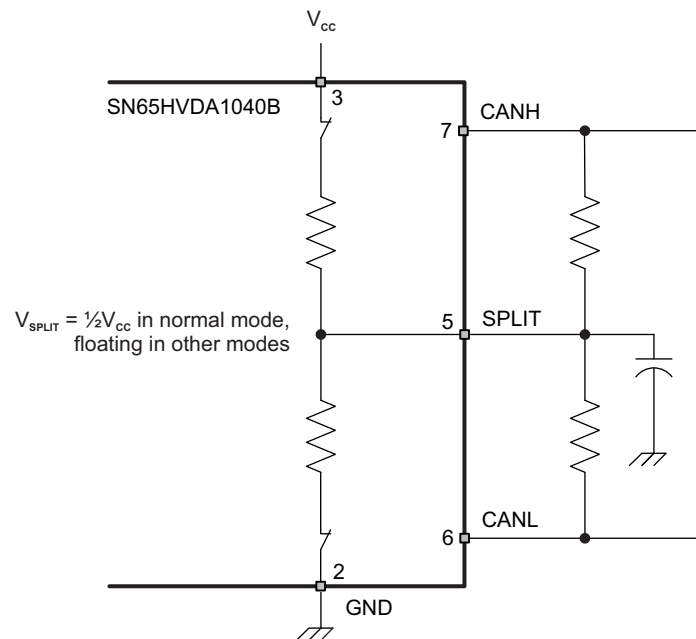

Figure 19. Split Pin Stabilization Circuitry and Application

9.2 Typical Application

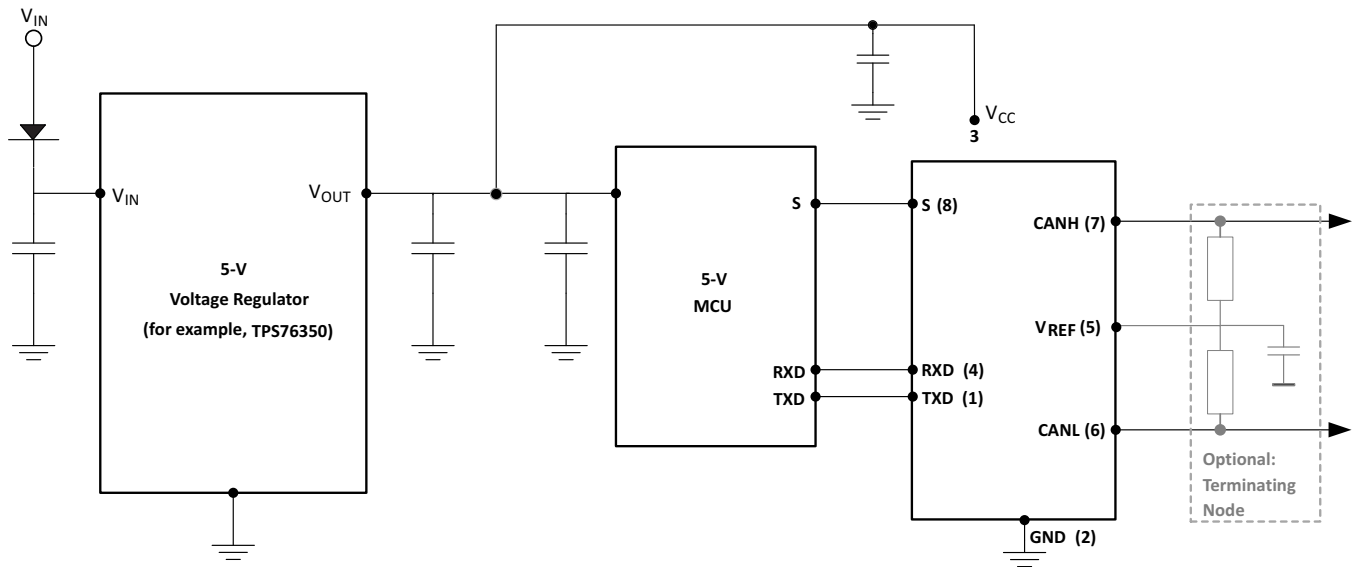

Figure 20. Typical Application Using Split Termination for Stabilization

9.2.1 Design Requirements

9.2.1.1 Bus Loading, Length, and Number of Nodes

The ISO 11898 Standard specifies up to 1 Mbps data rate, maximum bus length of 40 meters, maximum drop line (stub) length of 0.3 meters, and a maximum of 30 nodes to a bus. However, with careful network design, the system may have longer cables, longer stub lengths, and many more nodes to a bus. Many CAN organizations and standards have scaled the use of CAN for applications outside the original ISO 11898 standard. They have made system-level trade-offs for data rate, cable length, and parasitic loading of the bus. Examples of some of these specifications are ARINC825, CANopen, CAN Kingdom, DeviceNet, and NMEA200.

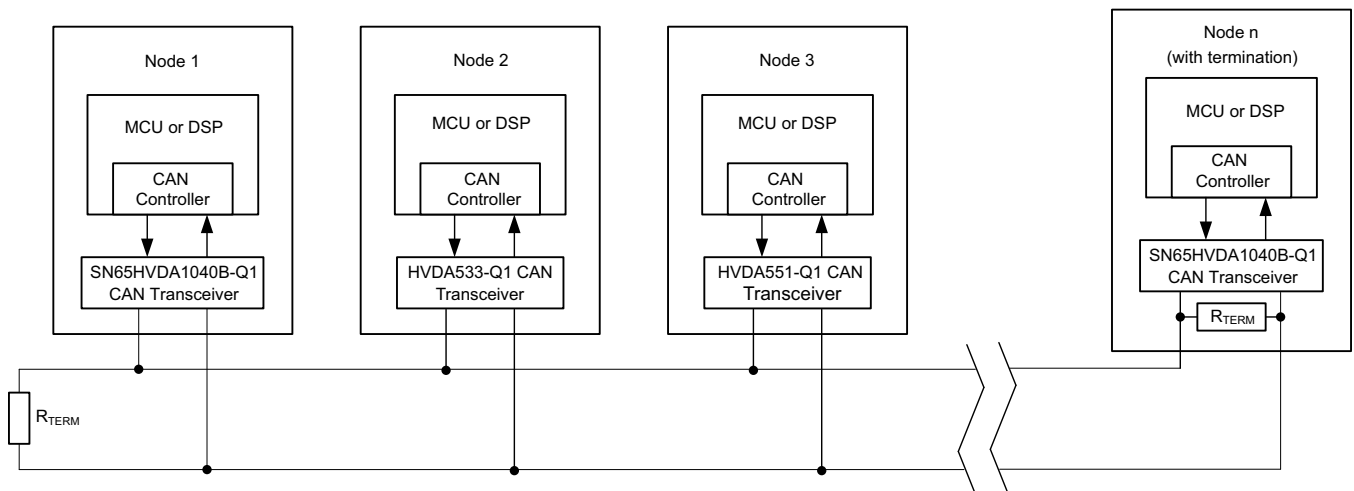

Figure 21. Typical CAN Bus Drawing

Typical Application (continued)

A high number of nodes requires a transceiver with high input impedance and wide common-mode range such as the SN65HVDA1040B-Q1 CAN transceiver. ISO 11898-2 specifies the driver differential output with a 60- Ω load (two 120- Ω termination resistors in parallel) and the differential output must be greater than 1.5 V. The SN65HVDA1040B-Q1 device is specified to meet the 1.5-V requirement with a 60- Ω load, and additionally specified with a differential output voltage minimum of 1.2 V across a common-mode range of -2 V to 7 V through a 330- Ω coupling network. This network represents the bus loading of 90 SN65HVDA1040B-Q1 transceivers based on their minimum differential input resistance of 30 k Ω . Therefore, the SN65HVDA1040B-Q1 supports up to 90 transceivers on a single bus segment with margin to the 1.2-V minimum differential input voltage requirement at each node.

For CAN network design, margin must be given for signal loss across the system and cabling, parasitic loadings, network imbalances, ground offsets and signal integrity thus a practical maximum number of nodes may be lower. Bus length may also be extended beyond the original ISO 11898 standard of 40 meters by careful system design and data rate tradeoffs. For example, CANopen network design guidelines allow the network to be up to 1-km with changes in the termination resistance, cabling, less than 64 nodes and significantly lowered data rate.

This flexibility in CAN network design is one of the key strengths of the various extensions and additional standards that have been built on the original ISO 11898 CAN standard.

9.2.1.2 CAN Termination

The ISO 11898 standard specifies the interconnect to be a twisted pair cable (shielded or unshielded) with 120- Ω characteristic impedance (Z_0). Resistors equal to the characteristic impedance of the line should be used to terminate both ends of the cable to prevent signal reflections. Unterminated drop lines (stubs) connecting nodes to the bus should be kept as short as possible to minimize signal reflections. The termination may be on the cable or in a node, but if nodes may be removed from the bus the termination must be carefully placed so that it is not removed from the bus.

Termination is typically a 120- Ω resistor at each end of the bus. If filtering and stabilization of the common-mode voltage of the bus is desired, then split termination may be used (see [Figure 22](#) and [Using SPLIT With Split Termination](#)).

Care should be taken when determining the power ratings of the termination resistors. A typical worst case fault condition is if the system power supply and ground were shorted across the termination resistance which would result in much higher current through the termination resistance than the CAN transceiver's current limit.

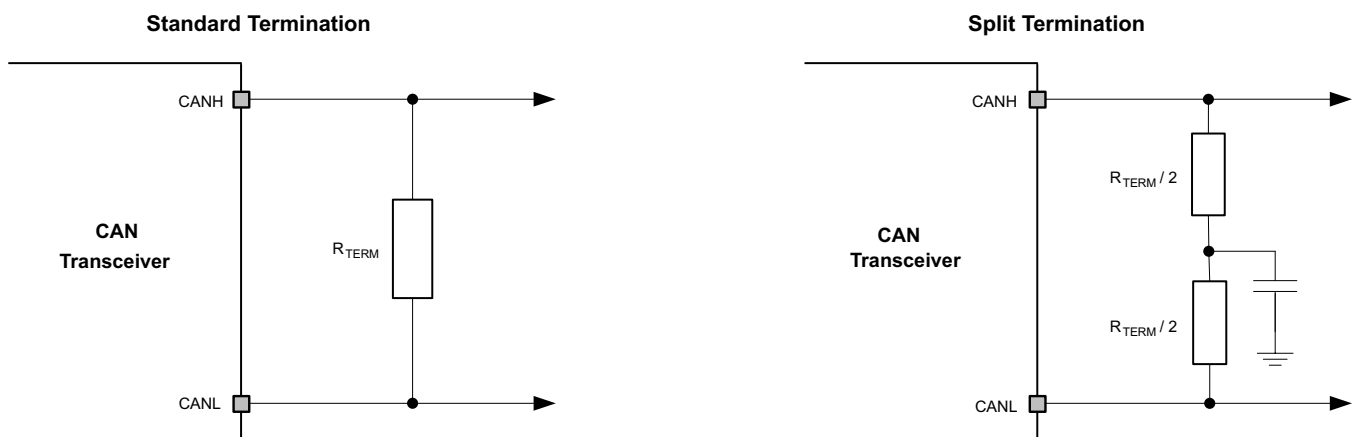

Figure 22. CAN Termination Schematic

9.2.1.3 Loop Propagation Delay

Transceiver loop delay is a measure of the overall device propagation delay, consisting of the delay from the driver input (the TXD pin) to the differential outputs (the CANH and CANL pins), plus the delay from the receiver inputs (the CANH and CANL) to its output (the RXD pin). A typical loop delay for the SN65HVDA1040B-Q1 transceiver is displayed in [Figure 24](#) and [Figure 25](#).

Typical Application (continued)

9.2.2 Detailed Design Procedure

9.2.2.1 Transient Voltage Suppressor (TVS) Diodes

Transient voltage suppressors are the preferred protection components for a CAN bus due to their low capacitance, which allows them to be designed into every node of a multinode network without requiring a reduction in data rate. With response times of a few picoseconds and power ratings of up to several kilowatts, TVS diodes present the most effective protection against ESD, burst, and surge transients.

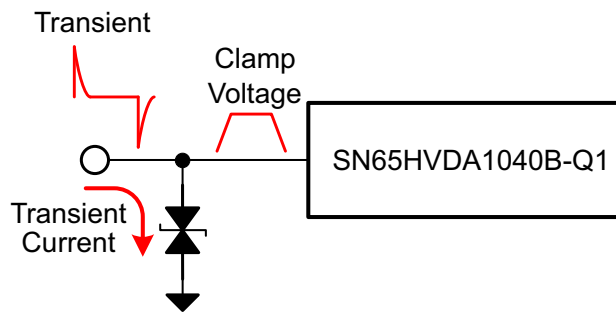
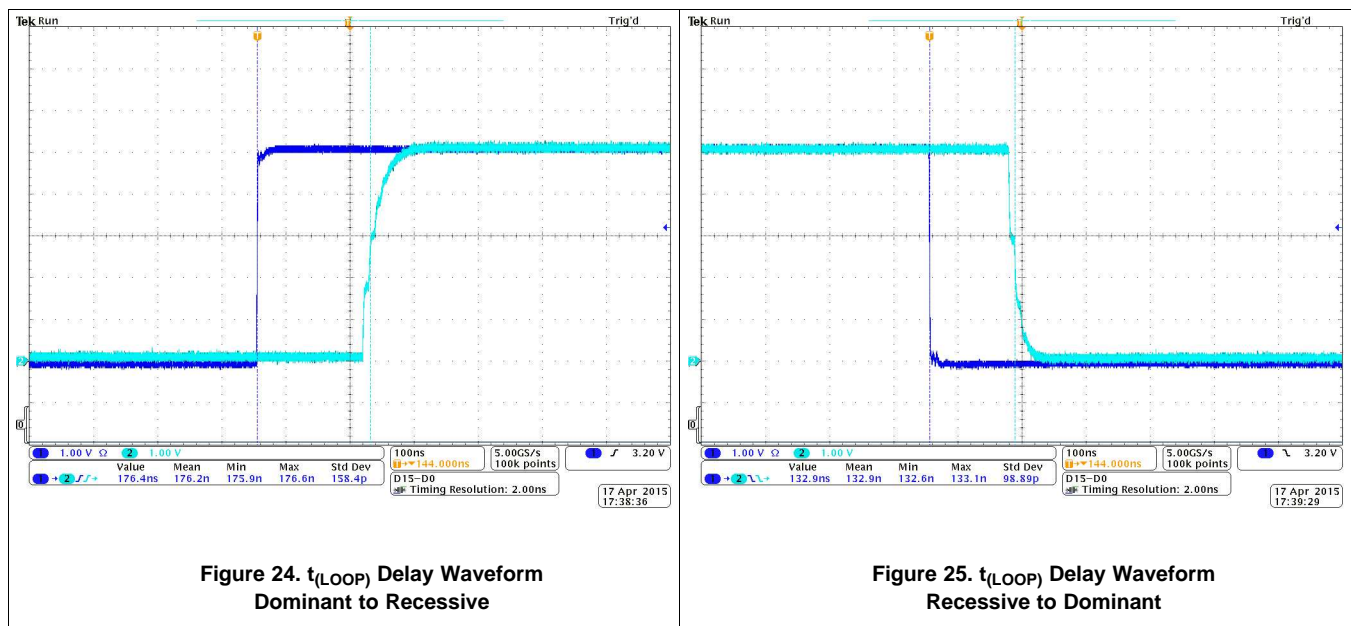

Figure 23. Transient Voltage Suppressor (TVS) Diodes Schematic

9.2.3 Application Curves



10 Power Supply Recommendations

To ensure reliable operation at all data rates and supply voltages, each supply should be decoupled with a 100-nF ceramic capacitor located as close as possible to the V_{CC} supply pins as possible. The TPS76350 device is a linear voltage regulator suitable for the 5-V supply rail.

11 Layout

11.1 Layout Guidelines

In order for the PCB design to be successful, start with design of the protection and filtering circuitry. Because ESD and EFT transients have a wide frequency bandwidth from approximately 3-MHz to 3-GHz, high-frequency layout techniques must be applied during PCB design. On-chip IEC ESD protection is good for laboratory and portable equipment but is usually not sufficient for EFT and surge transients occurring in industrial environments. Therefore robust and reliable bus node design requires the use of external transient protection devices at the bus connectors. Placement at the connector also prevents these harsh transient events from propagating further into the PCB and system.

- Use V_{CC} and ground planes to provide low inductance.

NOTE

High-frequency current follows the path of least inductance and not the path of least resistance.

- Design the bus protection components in the direction of the signal path. Do not force the transient current to divert from the signal path to reach the protection device. An example placement of the Transient Voltage Suppression (TVS) device indicated as D1 (either bidirectional diode or varistor solution) and bus filter capacitors C5 and C7 are shown in [Figure 26](#).
- The bus transient protection and filtering components should be placed as close to the bus connector, J1, as possible. This prevents transients, ESD and noise from penetrating onto the board and disturbing other devices.
- Bus termination: [Figure 22](#) shows split termination. This is where the termination is split into two resistors, R5 and R6, with the center or split tap of the termination connected to ground through capacitor C6. Split termination provides common-mode filtering for the bus. When termination is placed on the board instead of directly on the bus, care must be taken to ensure the terminating node is not removed from the bus as this causes signal integrity issues if the bus is not properly terminated on both ends.
- Bypass and bulk capacitors should be placed as close as possible to the supply pins of transceiver, examples include C2 and C3 (V_{CC}).
- Use at least two vias for V_{CC} and ground connections of bypass capacitors and protection devices to minimize trace and via inductance.
- To limit current of digital lines, serial resistors may be used. Examples are R1, R2, R3, and R4.
- To filter noise on the digital IO lines, a capacitor may be used close to the input side of the IO as shown by C1 and C4.
- Because the internal pullup and pulldown biasing of the device is weak for floating pins, an external 1-k Ω to 10- k Ω pullup or pulldown resistor should be used to bias the state of the pin more strongly against noise during transient events.
- Pin 1: If an open-drain host processor is used to drive the TXD pin of the device an external pullup resistor between 1 k Ω and 10 k Ω should be used to drive the recessive input state of the device.
- Pin 5: SPLIT should be connected to the center point of a split termination scheme to help stabilize the common-mode voltage to $V_{CC}/2$. If SPLIT is unused it should be left floating.
- Pin 8: Is shown assuming the mode pin, STB, is used. If the device only used in normal mode, R3 is not needed and the pads of C4 could be used for the pulldown resistor to GND.

11.2 Layout Example

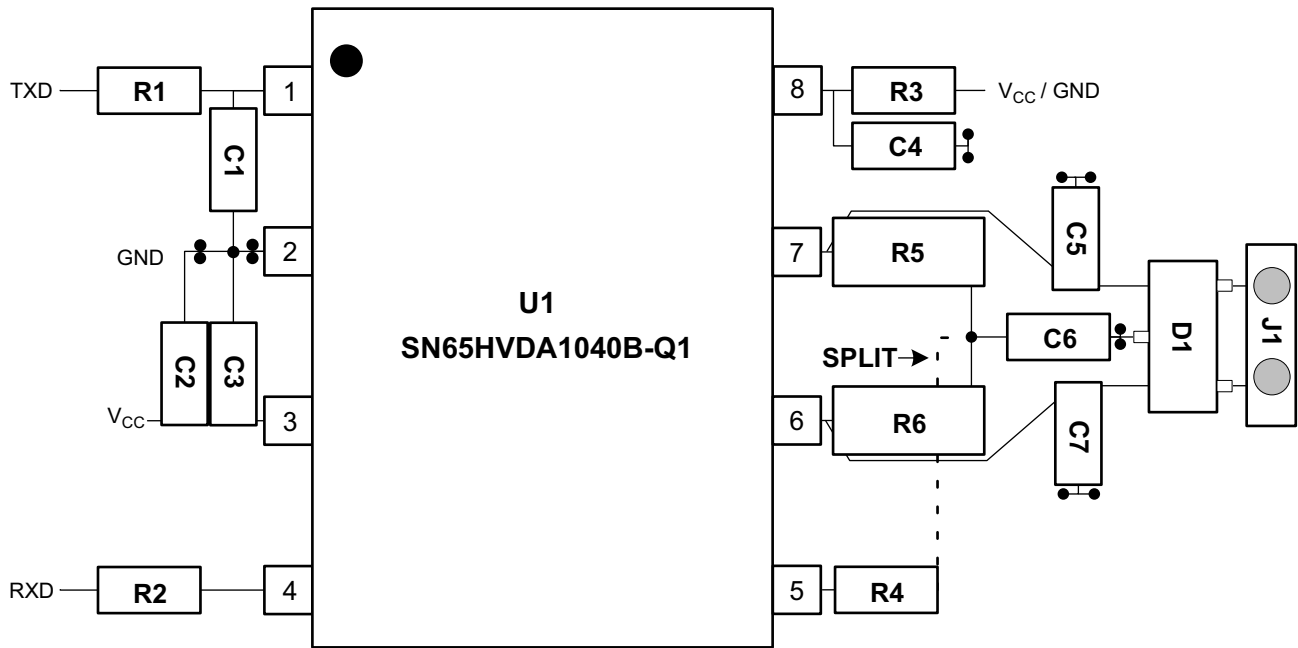

Figure 26. Typical CAN Bus Layout Example

11.3 ESD Protection

A typical application that employs a CAN bus network may require some form of ESD, burst, and surge protection to shield the CAN transceiver against unwanted transients that can potentially damage the transceiver. To help shield the SN65HVDA1040B-Q1 transceiver against these high energy transients, transient voltage suppressors can be implemented on the CAN differential bus terminals. These devices help absorb the impact of an ESD, burst, and/or surge strike.

12 デバイスおよびドキュメントのサポート

12.1 ドキュメントのサポート

12.1.1 関連資料

関連資料については、以下を参照してください。

12.2 ドキュメントの更新通知を受け取る方法

ドキュメントの更新についての通知を受け取るには、ti.comのデバイス製品フォルダを開いてください。右上の「アラートを受け取る」をクリックして登録すると、変更されたすべての製品情報に関するダイジェストを毎週受け取れます。変更の詳細については、修正されたドキュメントに含まれている改訂履歴をご覧ください。

12.3 コミュニティ・リソース

The following links connect to TI community resources. Linked contents are provided "AS IS" by the respective contributors. They do not constitute TI specifications and do not necessarily reflect TI's views; see TI's [Terms of Use](#).

TI E2E™ Online Community *TI's Engineer-to-Engineer (E2E) Community*. Created to foster collaboration among engineers. At e2e.ti.com, you can ask questions, share knowledge, explore ideas and help solve problems with fellow engineers.

Design Support *TI's Design Support* Quickly find helpful E2E forums along with design support tools and contact information for technical support.

12.4 商標

E2E is a trademark of Texas Instruments.
All other trademarks are the property of their respective owners.

12.5 静電気放電に関する注意事項



これらのデバイスは、限定的なESD(静電破壊)保護機能を内蔵しています。保存時または取り扱い時は、MOSゲートに対する静電破壊を防止するために、リード線同士をショートさせておくか、デバイスを導電フォームに入れる必要があります。

12.6 Glossary

[SLYZ022](#) — *TI Glossary*.

This glossary lists and explains terms, acronyms, and definitions.

13 メカニカル、パッケージ、および注文情報

以降のページには、メカニカル、パッケージ、および注文に関する情報が記載されています。この情報は、そのデバイスについて利用可能な最新のデータです。このデータは予告なく変更されることがあり、ドキュメントが改訂される場合もあります。本データシートのブラウザ版を使用されている場合は、画面左側の説明をご覧ください。

PACKAGING INFORMATION

Orderable Device	Status (1)	Package Type	Package Drawing	Pins	Package Qty	Eco Plan (2)	Lead finish/ Ball material (6)	MSL Peak Temp (3)	Op Temp (°C)	Device Marking (4/5)	Samples
SN65HVDA1040BQDRQ1	ACTIVE	SOIC	D	8	2500	RoHS & Green	NIPDAU	Level-1-260C-UNLIM	-40 to 125	A1040B	Samples

(1) The marketing status values are defined as follows:

ACTIVE: Product device recommended for new designs.

LIFEBUY: TI has announced that the device will be discontinued, and a lifetime-buy period is in effect.

NRND: Not recommended for new designs. Device is in production to support existing customers, but TI does not recommend using this part in a new design.

PREVIEW: Device has been announced but is not in production. Samples may or may not be available.

OBSOLETE: TI has discontinued the production of the device.

(2) **RoHS:** TI defines "RoHS" to mean semiconductor products that are compliant with the current EU RoHS requirements for all 10 RoHS substances, including the requirement that RoHS substance do not exceed 0.1% by weight in homogeneous materials. Where designed to be soldered at high temperatures, "RoHS" products are suitable for use in specified lead-free processes. TI may reference these types of products as "Pb-Free".

RoHS Exempt: TI defines "RoHS Exempt" to mean products that contain lead but are compliant with EU RoHS pursuant to a specific EU RoHS exemption.

Green: TI defines "Green" to mean the content of Chlorine (Cl) and Bromine (Br) based flame retardants meet JS709B low halogen requirements of <=1000ppm threshold. Antimony trioxide based flame retardants must also meet the <=1000ppm threshold requirement.

(3) MSL, Peak Temp. - The Moisture Sensitivity Level rating according to the JEDEC industry standard classifications, and peak solder temperature.

(4) There may be additional marking, which relates to the logo, the lot trace code information, or the environmental category on the device.

(5) Multiple Device Markings will be inside parentheses. Only one Device Marking contained in parentheses and separated by a "-" will appear on a device. If a line is indented then it is a continuation of the previous line and the two combined represent the entire Device Marking for that device.

(6) Lead finish/Ball material - Orderable Devices may have multiple material finish options. Finish options are separated by a vertical ruled line. Lead finish/Ball material values may wrap to two lines if the finish value exceeds the maximum column width.

Important Information and Disclaimer: The information provided on this page represents TI's knowledge and belief as of the date that it is provided. TI bases its knowledge and belief on information provided by third parties, and makes no representation or warranty as to the accuracy of such information. Efforts are underway to better integrate information from third parties. TI has taken and continues to take reasonable steps to provide representative and accurate information but may not have conducted destructive testing or chemical analysis on incoming materials and chemicals. TI and TI suppliers consider certain information to be proprietary, and thus CAS numbers and other limited information may not be available for release.

In no event shall TI's liability arising out of such information exceed the total purchase price of the TI part(s) at issue in this document sold by TI to Customer on an annual basis.

TAPE AND REEL INFORMATION

QUADRANT ASSIGNMENTS FOR PIN 1 ORIENTATION IN TAPE

*All dimensions are nominal

Device	Package Type	Package Drawing	Pins	SPQ	Reel Diameter (mm)	Reel Width W1 (mm)	A0 (mm)	B0 (mm)	K0 (mm)	P1 (mm)	W (mm)	Pin1 Quadrant
SN65HVDA1040BQDRQ1	SOIC	D	8	2500	330.0	12.4	6.4	5.2	2.1	8.0	12.0	Q1

TAPE AND REEL BOX DIMENSIONS

*All dimensions are nominal

Device	Package Type	Package Drawing	Pins	SPQ	Length (mm)	Width (mm)	Height (mm)
SN65HVDA1040BQDRQ1	SOIC	D	8	2500	356.0	356.0	35.0



D0008A

PACKAGE OUTLINE

SOIC - 1.75 mm max height

SMALL OUTLINE INTEGRATED CIRCUIT



4214825/C 02/2019

NOTES:

- Linear dimensions are in inches [millimeters]. Dimensions in parenthesis are for reference only. Controlling dimensions are in inches. Dimensioning and tolerancing per ASME Y14.5M.
- This drawing is subject to change without notice.
- This dimension does not include mold flash, protrusions, or gate burrs. Mold flash, protrusions, or gate burrs shall not exceed $.006$ [0.15] per side.
- This dimension does not include interlead flash.
- Reference JEDEC registration MS-012, variation AA.

EXAMPLE BOARD LAYOUT

D0008A

SOIC - 1.75 mm max height

SMALL OUTLINE INTEGRATED CIRCUIT



LAND PATTERN EXAMPLE
 EXPOSED METAL SHOWN
 SCALE:8X



SOLDER MASK DETAILS

4214825/C 02/2019

NOTES: (continued)

- 6. Publication IPC-7351 may have alternate designs.
- 7. Solder mask tolerances between and around signal pads can vary based on board fabrication site.

EXAMPLE STENCIL DESIGN

D0008A

SOIC - 1.75 mm max height

SMALL OUTLINE INTEGRATED CIRCUIT



SOLDER PASTE EXAMPLE
BASED ON .005 INCH [0.125 MM] THICK STENCIL
SCALE:8X

4214825/C 02/2019

NOTES: (continued)

8. Laser cutting apertures with trapezoidal walls and rounded corners may offer better paste release. IPC-7525 may have alternate design recommendations.
9. Board assembly site may have different recommendations for stencil design.

重要なお知らせと免責事項

TI は、技術データと信頼性データ(データシートを含みます)、設計リソース(リファレンス・デザインを含みます)、アプリケーションや設計に関する各種アドバイス、Web ツール、安全性情報、その他のリソースを、欠陥が存在する可能性のある「現状のまま」提供しており、商品性および特定目的に対する適合性の黙示保証、第三者の知的財産権の非侵害保証を含むいかなる保証も、明示的または黙示的にかかわらず拒否します。

これらのリソースは、TI 製品を使用する設計の経験を積んだ開発者への提供を意図したものです。(1) お客様のアプリケーションに適した TI 製品の選定、(2) お客様のアプリケーションの設計、検証、試験、(3) お客様のアプリケーションに該当する各種規格や、その他のあらゆる安全性、セキュリティ、規制、または他の要件への確実な適合に関する責任を、お客様のみが単独で負うものとし、

上記の各種リソースは、予告なく変更される可能性があります。これらのリソースは、リソースで説明されている TI 製品を使用するアプリケーションの開発の目的でのみ、TI はその使用をお客様に許諾します。これらのリソースに関して、他の目的で複製することや掲載することは禁止されています。TI や第三者の知的財産権のライセンスが付与されている訳ではありません。お客様は、これらのリソースを自身で使用した結果発生するあらゆる申し立て、損害、費用、損失、責任について、TI およびその代理人を完全に補償するものとし、TI は一切の責任を拒否します。

TI の製品は、[TI の販売条件](#)、または [ti.com](#) やかかる TI 製品の関連資料などのいずれかを通じて提供する適用可能な条項の下で提供されています。TI がこれらのリソースを提供することは、適用される TI の保証または他の保証の放棄の拡大や変更を意味するものではありません。

お客様がいかなる追加条項または代替条項を提案した場合でも、TI はそれらに異議を唱え、拒否します。

郵送先住所 : Texas Instruments, Post Office Box 655303, Dallas, Texas 75265
Copyright © 2024, Texas Instruments Incorporated