

# SN74LV157A クワッド、2ライン入力1ライン出力、データ・セクタ/マルチプレクサ

## 1 特長

- 2V~5.5V の  $V_{CC}$  で動作
- 5.5V までの入力電圧に対応
- 最大  $t_{pd}$  7.5ns (5V 時)
- 標準  $V_{OLP}$  (出力グラウンド・バウンス)  $< 0.8V$  ( $V_{CC} = 3.3V$ ,  $T_A = 25^\circ C$ )
- 標準  $V_{OHV}$  (出力  $V_{OH}$  アンダーシュート)  $> 2V$  ( $V_{CC}$ ,  $T_A = 25^\circ C$ )
- JESD 78, Class II 準拠で 100mA 超のラッチアップ性能

## 2 アプリケーション

- サーバー
- LED ディスプレイ
- ネットワーク・スイッチ
- 通信インフラ
- モーター・ドライバ
- I/O エクスパンダ

## 3 説明

LV157A デバイスは、2V~5.5V の  $V_{CC}$  で動作するよう設計されたクワッド、2ライン入力1ライン出力、データ・セクタ/マルチプレクサです。

### パッケージ情報<sup>(1)</sup>

部品番号	パッケージ	本体サイズ (公称)
SN74LV157A	DB (SSOP, 16)	6.2mm × 5.3mm
	DGV (TVSOP, 16)	3.6mm × 4.4mm
	DW (SOIC, 16)	10.3mm × 7.5mm
	NS (SOP, 16)	10.3mm × 5.3mm
	PW (TSSOP, 16)	5mm × 4.4mm

(1) 利用可能なすべてのパッケージについては、このデータシートの末尾にある注文情報を参照してください。

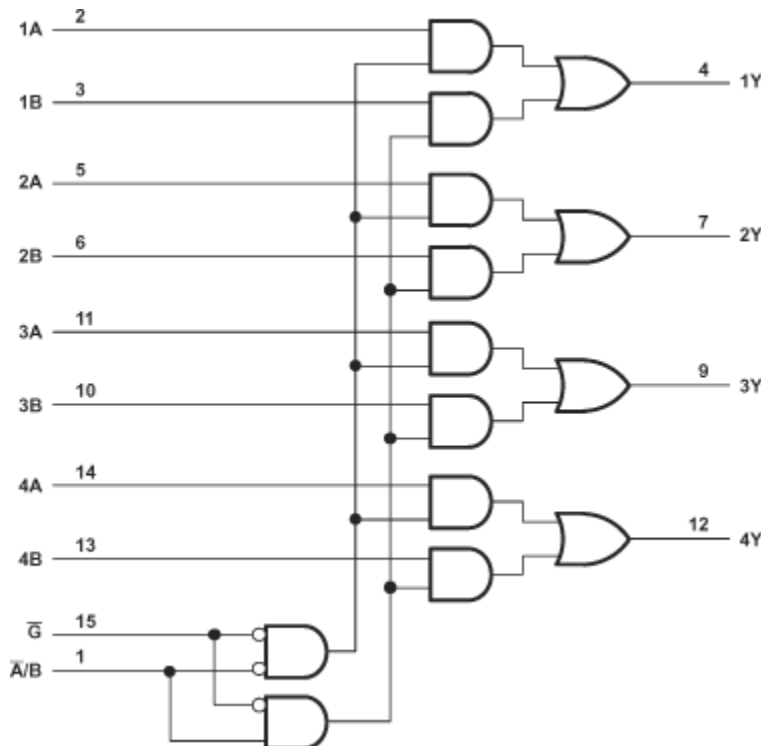

論理図 (正論理)



## Table of Contents

<b>1 特長</b> .....	<b>1</b>	<b>7 Parameter Measurement Information</b> .....	<b>8</b>
<b>2 アプリケーション</b> .....	<b>1</b>	<b>8 Detailed Description</b> .....	<b>9</b>
<b>3 説明</b> .....	<b>1</b>	8.1 Overview.....	9
<b>4 Revision History</b> .....	<b>2</b>	8.2 Functional Block Diagram.....	9
<b>5 Pin Configuration and Functions</b> .....	<b>3</b>	8.3 Device Functional Modes.....	9
<b>6 Specifications</b> .....	<b>4</b>	<b>9 Application and Implementation</b> .....	<b>10</b>
6.1 Absolute Maximum Ratings.....	4	9.1 Power Supply Recommendations.....	10
6.2 ESD Ratings.....	4	9.2 Layout.....	10
6.3 Recommended Operating Conditions .....	5	<b>10 Device and Documentation Support</b> .....	<b>11</b>
6.4 Thermal Information.....	5	10.1 Documentation Support.....	11
6.5 Electrical Characteristics.....	5	10.2 ドキュメントの更新通知を受け取る方法.....	11
6.6 Switching Characteristics, $V_{CC} = 2.5\text{ V} \pm 0.2\text{ V}$ .....	6	10.3 サポート・リソース.....	11
6.7 Switching Characteristics, $V_{CC} = 3.3\text{ V} \pm 0.3\text{ V}$ .....	6	10.4 静電気放電に関する注意事項.....	11
6.8 Switching Characteristics, $V_{CC} = 5\text{ V} \pm 0.5\text{ V}$ .....	6	10.5 用語集.....	11
6.9 Noise Characteristics.....	7	<b>11 Mechanical, Packaging, and Orderable Information</b> .....	<b>12</b>
6.10 Operating Characteristics.....	7		

## 4 Revision History

資料番号末尾の英字は改訂を表しています。その改訂履歴は英語版に準じています。

Changes from Revision F (April 1998) to Revision G (March 2023)	Page
• 「アプリケーション」、「パッケージ情報」表、「ピンの機能」表、「ESD 定格」表、「熱に関する情報」表、「デバイスの機能モード」、「アプリケーションと実装」セクション、「電源に関する推奨事項」セクション、「レイアウト」セクション、「デバイスおよびドキュメントのサポート」セクション、および「メカニカル、パッケージ、および注文情報」セクションを追加 .....	1

## 5 Pin Configuration and Functions



图 5-1. D, DB, DGV, NS, or PW Package (Top View)

表 5-1. Pin Functions

PIN		I/O <sup>(1)</sup>	DESCRIPTION
NO.	NAME		
1	$\bar{A}/B$	I	Address select
2	1A	I	Channel 1, data input A
3	1B	I	Channel 1, data input B
4	1Y	I	Channel 1, data output
5	2A	O	Channel 2, data input A
6	2B	O	Channel 2, data input B
7	2Y	I	Channel 2, data output
8	GND	—	Ground
9	3Y	I	Channel 3, data output
10	3B	I	Channel 3, data input B
11	3A	I	Channel 3, data input A
12	4Y	I	Channel 4, data output
13	4B	I	Channel 4, data input B
14	4A	I	Channel 4, data input A
15	$\bar{G}$	I	Output strobe, active low
16	V <sub>CC</sub>	—	Positive supply

## 6 Specifications

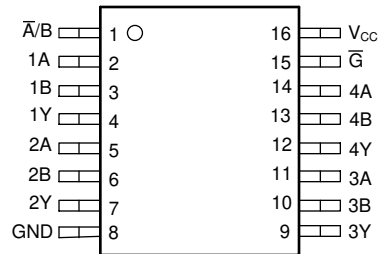
### 6.1 Absolute Maximum Ratings

over operating free-air temperature range (unless otherwise noted)

		MIN	MAX	UNIT
$V_{CC}$	Supply voltage	-0.5	7	V
$V_I$	Input voltage <sup>1</sup>	-0.5	7	V
$V_O$	Output voltage range applied in high or low state <sup>1 (2)</sup>	-0.5	$V_{CC} + 0.5$	V
$V_O$	Output voltage range applied in power-off state <sup>1</sup>	-0.5	7	V
$I_{IK}$	Input clamp current	$V_I < 0$	-20	mA
$I_{OK}$	Output clamp current	$V_O < 0$	-50	mA
$I_O$	Continuous output current	$V_O = 0$ to $V_{CC}$	±25	mA
	Continuous current through $V_{CC}$ or GND		±50	mA
$T_{stg}$	Storage temperature	-65	150	°C

(1) This value is limited to 5.5 V maximum.

Stresses beyond those listed under "absolute maximum ratings" may cause permanent damage to the device. These are stress ratings only, and functional operation of the device at these or any other conditions beyond those indicated under "recommended operating conditions" is not implied. Exposure to absolute-maximum-rated conditions for extended periods may affect device reliability.

### 6.2 ESD Ratings

		VALUE	UNIT
$V_{(ESD)}$	Electrostatic discharge	Human-Body Model (A114-A) <sup>(1)</sup>	±2000
		Machine Model (A115-A)	±200
		Charged-Device Model (C101) <sup>(2)</sup>	±1000

(1) JEDEC document JEP155 states that 500-V HBM allows safe manufacturing with a standard ESD control process.

(2) JEDEC document JEP157 states that 250-V CDM allows safe manufacturing with a standard ESD control process.

### 6.3 Recommended Operating Conditions

			MIN	MAX	UNIT
V <sub>CC</sub>	Supply voltage		2	5.5	V
V <sub>IH</sub>	High-level input voltage	V <sub>CC</sub> = 2 V	1.5		V
		V <sub>CC</sub> = 2.3 V to 2.7 V	V <sub>CC</sub> × 0.7		
		V <sub>CC</sub> = 3 V to 3.6 V	V <sub>CC</sub> × 0.7		
		V <sub>CC</sub> = 4.5 V to 5.5 V	V <sub>CC</sub> × 0.7		
V <sub>IL</sub>	Low-level input voltage	V <sub>CC</sub> = 2 V		0.5	V
		V <sub>CC</sub> = 2.3 V to 2.7 V		V <sub>CC</sub> × 0.3	
		V <sub>CC</sub> = 3 V to 3.6 V		V <sub>CC</sub> × 0.3	
		V <sub>CC</sub> = 4.5 V to 5.5 V		V <sub>CC</sub> × 0.3	
V <sub>I</sub>	Input voltage		0	5.5	V
V <sub>O</sub>	Output voltage		0	V <sub>CC</sub>	V
I <sub>OH</sub>	High-level output current	V <sub>CC</sub> = 2 V		-50	μA
		V <sub>CC</sub> = 2.3 V to 2.7 V		-2	mA
		V <sub>CC</sub> = 3 V to 3.6 V		6	
		V <sub>CC</sub> = 4.5 V to 5.5 V		-12	
I <sub>OL</sub>	Low-level output current	V <sub>CC</sub> = 2 V		50	
		V <sub>CC</sub> = 2.3 V to 2.7 V		2	mA
		V <sub>CC</sub> = 3 V to 3.6 V		6	
		V <sub>CC</sub> = 4.5 V to 5.5 V		12	
Δt/Δv	Input transition rise or fall rate	V <sub>CC</sub> = 2.3 V to 2.7 V	0	200	
		V <sub>CC</sub> = 3 V to 3.6 V	0	100	
		V <sub>CC</sub> = 4.5 V to 5.5 V	0	20	
T <sub>A</sub>	Operating free-air temperature		-40	85	°C

### 6.4 Thermal Information

THERMAL METRIC <sup>(1)</sup>		SN74LV157A					UNIT
		D	DB	DGV	NS	PW	
		16 PINS	16 PINS	16 PINS	16 PINS	16 PINS	
R <sub>θJA</sub>	Junction-to-ambient thermal resistance	73	82	120	64	108	°C/W

(1) For more information about traditional and new thermal metrics, see the *IC Package Thermal Metrics* application report ([SPRA953](#)).

### 6.5 Electrical Characteristics

over recommended operating free-air temperature range (unless otherwise noted)

PARAMETER	TEST CONDITIONS	V <sub>CC</sub>	MIN	TYP	MAX	UNIT
V <sub>OH</sub>	I <sub>OH</sub> = -50 μA	2 V to 5.5 V	V <sub>CC</sub> -0.1			V
	I <sub>OH</sub> = -2 mA	2.3 V	2			
	I <sub>OH</sub> = -6 mA	3 V	2.48			
	I <sub>OH</sub> = -12 mA	4.5 V	3.8			

over recommended operating free-air temperature range (unless otherwise noted)

PARAMETER	TEST CONDITIONS	$V_{CC}$	MIN	TYP	MAX	UNIT
$V_{OL}$	$I_{OL} = 50 \mu A$	2 V to 5.5 V			0.1	V
	$I_{OL} = 2 \text{ mA}$	2.3 V			0.4	
	$I_{OL} = 6 \text{ mA}$	3 V			0.44	
	$I_{OL} = 12 \text{ mA}$	4.5 V			0.55	
$I_I$	$V_I = 5.5 \text{ V}$ or GND	0 to 5.5 V			$\pm 1$	$\mu A$
$I_{CC}$	$V_I = V_{CC}$ or GND, $I_O = 0$	5.5 V			20	$\mu A$
$I_{off}$	$V_I$ or $V_O = 0$ to 5.5 V	0			5	$\mu A$
$C_i$	$V_I = V_{CC}$ or GND	3.3 V		1.7		pF

## 6.6 Switching Characteristics, $V_{CC} = 2.5 \text{ V} \pm 0.2 \text{ V}$

over recommended operating free-air temperature range,  $V_{CC} = 2.5 \text{ V} \pm 0.2 \text{ V}$  (unless otherwise noted) (see [Load Circuit and Voltage Waveforms](#))

PARAMETER	FROM (INPUT)	TO (OUTPUT)	LOAD CAPACITANCE	TA = 25°C			SN74LV157A		UNIT
				MIN	TYP	MAX	MIN	MAX	
$t_{pd}$	A or B	Y	$C_L = 15 \text{ pF}$		7.4 <sup>1</sup>	15.9 <sup>1</sup>	1	19.5	ns
	$\bar{A}/B$	Y			7.9 <sup>1</sup>	19.4 <sup>1</sup>	1	23.5	
	$\bar{C}$	Y			7.8 <sup>1</sup>	19.8 <sup>1</sup>	1	24	
$t_{pd}$	A or B	Y	$C_L = 50 \text{ pF}$		9.4	18.8	1	22	ns
	$\bar{A}$	Y			10.8	22.3	1	26	
	$\bar{C}$	Y			9.6	22.7	1	26.5	

1. On products compliant to MIL-PRF-38535, this parameter is not production tested.

## 6.7 Switching Characteristics, $V_{CC} = 3.3 \text{ V} \pm 0.3 \text{ V}$

over recommended operating free-air temperature range,  $V_{CC} = 3.3 \text{ V} \pm 0.3 \text{ V}$  (unless otherwise noted) (see [Load Circuit and Voltage Waveforms](#))

PARAMETER	FROM (INPUT)	TO (OUTPUT)	LOAD CAPACITANCE	TA = 25°C			SN74LV157A		UNIT
				MIN	TYP	MAX	MIN	MAX	
$t_{pd}$	A or B	Y	$C_L = 15 \text{ pF}$		5.2 <sup>1</sup>	9.7 <sup>1</sup>	1	11.5	ns
	$\bar{A}/B$	Y			5.8 <sup>1</sup>	13.2 <sup>1</sup>	1	15.5	
	$\bar{C}$	Y			5.5 <sup>1</sup>	13.6 <sup>1</sup>	1	16	
$t_{pd}$	A or B	Y	$C_L = 50 \text{ pF}$		6.7	13.2	1	15	ns
	$\bar{A}$	Y			7.6	16.7	1	19	
	$\bar{C}$	Y			7	17.1	1	19.5	

1. On products compliant to MIL-PRF-38535, this parameter is not production tested.

## 6.8 Switching Characteristics, $V_{CC} = 5 \text{ V} \pm 0.5 \text{ V}$

over recommended operating free-air temperature range,  $V_{CC} = 5 \text{ V} \pm 0.5 \text{ V}$  (unless otherwise noted) (see [Load Circuit and Voltage Waveforms](#))

PARAMETER	FROM (INPUT)	TO (OUTPUT)	LOAD CAPACITANCE	TA = 25°C			SN74LV157A		UNIT
				MIN	TYP	MAX	MIN	MAX	
$t_{pd}$	A or B	Y	$C_L = 15 \text{ pF}$		3.6 <sup>1</sup>	6.4 <sup>1</sup>	1	7.5	ns
	$\bar{A}/B$	Y			4.1 <sup>1</sup>	8.1 <sup>1</sup>	1	9.5	
	$\bar{C}$	Y			3.8 <sup>1</sup>	8.6 <sup>1</sup>	1	10	

over recommended operating free-air temperature range,  $V_{CC} = 5\text{ V} \pm 0.5\text{ V}$  (unless otherwise noted) (see [Load Circuit and Voltage Waveforms](#))

PARAMETER	FROM (INPUT)	TO (OUTPUT)	LOAD CAPACITANCE	TA = 25°C			SN74LV157A		UNIT
				MIN	TYP	MAX	MIN	MAX	
t <sub>pd</sub>	A or B	Y	C <sub>L</sub> = 50 pF		4.8	8.4	1	9.5	ns
	$\bar{A}$	Y			5.4	10.1	1	11.5	
	$\bar{B}$	Y			5	10.6	1	12	

1. On products compliant to MIL-PRF-38535, this parameter is not production tested.

## 6.9 Noise Characteristics

$V_{CC} = 3.3\text{ V}$ ,  $C_L = 50\text{ pF}$ ,  $T_A = 25^\circ\text{C}$ <sup>(1)</sup>

PARAMETER		MIN	TYP	MAX	UNIT
V <sub>OL(P)</sub>	Quiet output, maximum dynamic V <sub>OL</sub>		0.3	0.8	V
V <sub>OL(V)</sub>	Quiet output, minimum dynamic V <sub>OL</sub>		-0.1	-0.8	V
V <sub>OH(V)</sub>	Quiet output, minimum dynamic V <sub>OH</sub>		3.2		V
V <sub>IH(D)</sub>	High-level dynamic input voltage	2.31			V
V <sub>IL(D)</sub>	Low-level dynamic input voltage			0.99	V

(1) Characteristics are for surface-mount packages only.

## 6.10 Operating Characteristics

T<sub>A</sub> = 25°C

PARAMETER		TEST CONDITIONS		V <sub>CC</sub>	TYP	UNIT
C <sub>pd</sub>	Power dissipation capacitance	C <sub>L</sub> = 50 pF	f = 10 MHz	3.3 V 5 V	12.1 13.1	pF

## 7 Parameter Measurement Information

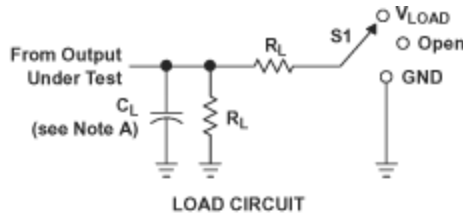

TEST	S1
$t_{PLH}/t_{PHL}$	Open
$t_{PLZ}/t_{PZL}$	$V_{LOAD}$
$t_{PHZ}/t_{PZH}$	GND

$V_{CC}$	INPUTS		$V_M$	$V_{LOAD}$	$C_L$	$R_L$	$V_{\Delta}$
	$V_I$	$t_r/t_f$					
2.7 V	2.7 V	$\leq 2.5$ ns	1.5 V	6 V	50 pF	500 $\Omega$	0.3 V
3.3 V $\pm$ 0.3 V	2.7 V	$\leq 2.5$ ns	1.5 V	6 V	50 pF	500 $\Omega$	0.3 V

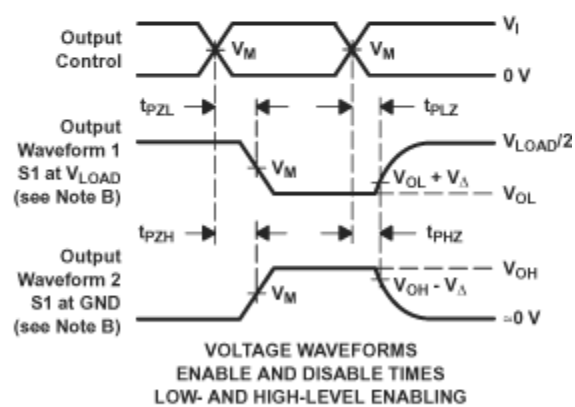
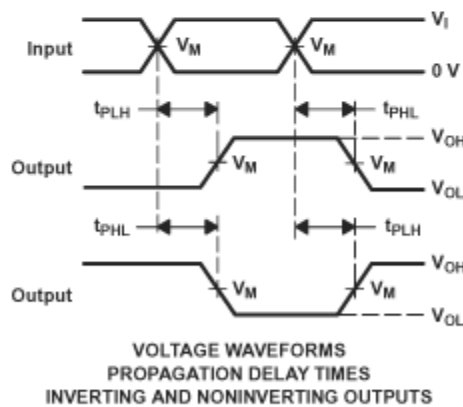
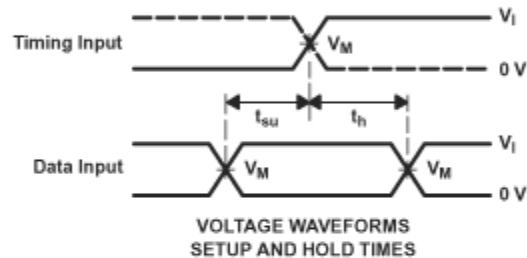
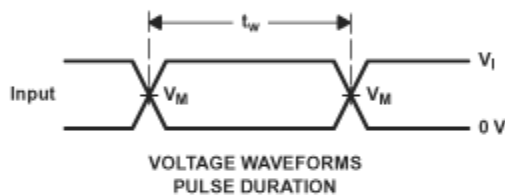

- NOTES: A.  $C_L$  includes probe and jig capacitance.
- B. Waveform 1 is for an output with internal conditions such that the output is low, except when disabled by the output control. Waveform 2 is for an output with internal conditions such that the output is high, except when disabled by the output control.
- C. All input pulses are supplied by generators having the following characteristics: PRR  $\leq$  10 MHz,  $Z_O = 50 \Omega$ .
- D. The outputs are measured one at a time, with one transition per measurement.
- E.  $t_{PLZ}$  and  $t_{PHZ}$  are the same as  $t_{dS}$ .
- F.  $t_{PZL}$  and  $t_{PZH}$  are the same as  $t_{dS}$ .
- G.  $t_{PLH}$  and  $t_{PHL}$  are the same as  $t_{pd}$ .
- H. All parameters and waveforms are not applicable to all devices.



## 8 Detailed Description

### 8.1 Overview

The 'LV157A devices contain inverters and drivers to supply full data selection to the four output gates. A separate strobe ( $\bar{G}$ ) input is provided. A 4-bit word is selected from one of two sources and is routed to the four outputs. The 'LV157A devices present true data.

### 8.2 Functional Block Diagram



图 8-1. Logic Diagram (Positive Logic)

### 8.3 Device Functional Modes

表 8-1. Function Table

INPUTS <sup>(1)</sup>		DATA		OUTPUT Y
$\bar{G}$	SELECT A/B	A	B	
H	X	X	X	L
L	L	L	X	L
L	L	H	X	H
L	H	X	L	L
L	H	X	H	H

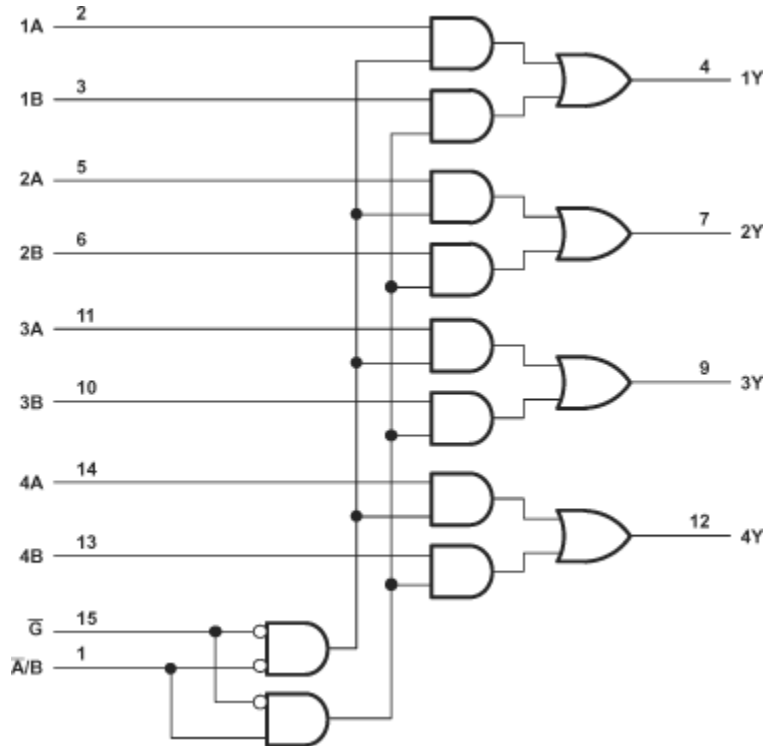
(1) H = High Voltage Level, L = Low Voltage Level, X = Do not Care, Z = High Impedance

## 9 Application and Implementation

### 注

以下のアプリケーション情報は、TI の製品仕様に含まれるものではなく、TI ではその正確性または完全性を保証いたしません。個々の目的に対する製品の適合性については、お客様の責任で判断していただくこととなります。お客様は自身の設計実装を検証しテストすることで、システムの機能を確認する必要があります。

### 9.1 Power Supply Recommendations

The power supply can be any voltage between the min and max supply voltage rating located in [セクション 6.3](#).

Each  $V_{CC}$  terminal should have a good bypass capacitor to prevent power disturbance. For devices with a single supply, a 0.1  $\mu\text{F}$  capacitor is recommended. If there are multiple  $V_{CC}$  terminals then 0.01  $\mu\text{F}$  or 0.022  $\mu\text{F}$  capacitors are recommended for each power terminal. It is ok to parallel multiple bypass capacitors to reject different frequencies of noise. 0.1  $\mu\text{F}$  and 1.0  $\mu\text{F}$  capacitors are commonly used in parallel. The bypass capacitor should be installed as close to the power terminal as possible for the best results.

### 9.2 Layout

#### 9.2.1 Layout Guidelines

When using multiple bit logic devices, inputs should not float. In many cases, functions or parts of functions of digital logic devices are unused. Some examples are when only two inputs of a triple-input AND gate are used, or when only 3 of the 4-buffer gates are used. Such unused input pins must not be left unconnected because the undefined voltages at the outside connections result in undefined operational states. All unused inputs of digital logic devices must be connected to a logic high or logic low voltage, as defined by the input voltage specifications, to prevent them from floating. The logic level that must be applied to any particular unused input depends on the function of the device. Generally, the inputs are tied to GND or  $V_{CC}$ , whichever makes more sense for the logic function or is more convenient.

##### 9.2.1.1 Layout Example



図 9-1. Layout Diagram

## 10 Device and Documentation Support

### 10.1 Documentation Support

#### 10.1.1 Related Documentation

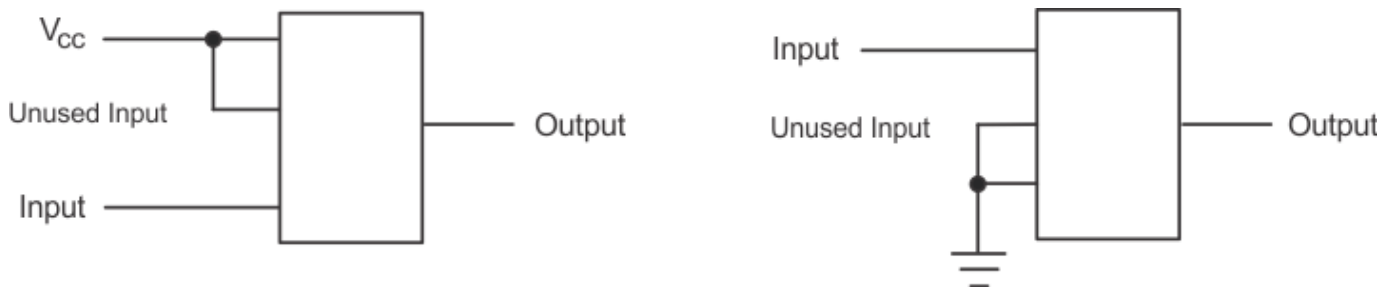
The table below lists quick access links. Categories include technical documents, support and community resources, tools and software, and quick access to sample or buy.

**表 10-1. Related Links**

PARTS	PRODUCT FOLDER	SAMPLE & BUY	TECHNICAL DOCUMENTS	TOOLS & SOFTWARE	SUPPORT & COMMUNITY
SN74LV157A	<a href="#">Click here</a>	<a href="#">Click here</a>	<a href="#">Click here</a>	<a href="#">Click here</a>	<a href="#">Click here</a>

### 10.2 ドキュメントの更新通知を受け取る方法

ドキュメントの更新についての通知を受け取るには、[ti.com](#) のデバイス製品フォルダを開いてください。「更新の通知を受け取る」をクリックして登録すると、変更されたすべての製品情報に関するダイジェストを毎週受け取れます。変更の詳細については、修正されたドキュメントに含まれている改訂履歴をご覧ください。

### 10.3 サポート・リソース

[TI E2E™ サポート・フォーラム](#)は、エンジニアが検証済みの回答と設計に関するヒントをエキスパートから迅速かつ直接得ることができる場所です。既存の回答を検索したり、独自の質問をしたりすることで、設計に必要な支援を迅速に得ることができます。

リンクされているコンテンツは、該当する貢献者により、現状のまま提供されるものです。これらは TI の仕様を構成するものではなく、必ずしも TI の見解を反映したものではありません。TI の[使用条件](#)を参照してください。

### Trademarks

TI E2E™ is a trademark of Texas Instruments.

すべての商標は、それぞれの所有者に帰属します。

### 10.4 静電気放電に関する注意事項



この IC は、ESD によって破損する可能性があります。テキサス・インスツルメンツは、IC を取り扱う際には常に適切な注意を払うことを推奨します。正しい取り扱いおよび設置手順に従わない場合、デバイスを破損するおそれがあります。

ESD による破損は、わずかな性能低下からデバイスの完全な故障まで多岐にわたります。精密な IC の場合、パラメータがわずかに変化するだけで公表されている仕様から外れる可能性があるため、破損が発生しやすくなっています。

### 10.5 用語集

[テキサス・インスツルメンツ用語集](#)

この用語集には、用語や略語の一覧および定義が記載されています。

## 11 Mechanical, Packaging, and Orderable Information

The following pages include mechanical, packaging, and orderable information. This information is the most current data available for the designated devices. This data is subject to change without notice and revision of this document. For browser-based versions of this data sheet, refer to the left-hand navigation.

**PACKAGING INFORMATION**

Orderable Device	Status (1)	Package Type	Package Drawing	Pins	Package Qty	Eco Plan (2)	Lead finish/ Ball material (6)	MSL Peak Temp (3)	Op Temp (°C)	Device Marking (4/5)	Samples
SN74LV157AD	OBSOLETE	SOIC	D	16		TBD	Call TI	Call TI	-40 to 85	LV157A	
SN74LV157ADBR	ACTIVE	SSOP	DB	16	2000	RoHS & Green	NIPDAU	Level-1-260C-UNLIM	-40 to 85	LV157A	Samples
SN74LV157ADGVR	ACTIVE	TVSOP	DGV	16	2000	RoHS & Green	NIPDAU	Level-1-260C-UNLIM	-40 to 85	LV157A	Samples
SN74LV157ADR	ACTIVE	SOIC	D	16	2500	RoHS & Green	NIPDAU	Level-1-260C-UNLIM	-40 to 85	LV157A	Samples
SN74LV157ANSR	ACTIVE	SO	NS	16	2000	RoHS & Green	NIPDAU	Level-1-260C-UNLIM	-40 to 85	74LV157A	Samples
SN74LV157APW	OBSOLETE	TSSOP	PW	16		TBD	Call TI	Call TI	-40 to 85	LV157A	
SN74LV157APWR	ACTIVE	TSSOP	PW	16	2000	RoHS & Green	NIPDAU   SN	Level-1-260C-UNLIM	-40 to 85	LV157A	Samples

(1) The marketing status values are defined as follows:

**ACTIVE:** Product device recommended for new designs.

**LIFEBUY:** TI has announced that the device will be discontinued, and a lifetime-buy period is in effect.

**NRND:** Not recommended for new designs. Device is in production to support existing customers, but TI does not recommend using this part in a new design.

**PREVIEW:** Device has been announced but is not in production. Samples may or may not be available.

**OBSOLETE:** TI has discontinued the production of the device.

(2) **RoHS:** TI defines "RoHS" to mean semiconductor products that are compliant with the current EU RoHS requirements for all 10 RoHS substances, including the requirement that RoHS substance do not exceed 0.1% by weight in homogeneous materials. Where designed to be soldered at high temperatures, "RoHS" products are suitable for use in specified lead-free processes. TI may reference these types of products as "Pb-Free".

**RoHS Exempt:** TI defines "RoHS Exempt" to mean products that contain lead but are compliant with EU RoHS pursuant to a specific EU RoHS exemption.

**Green:** TI defines "Green" to mean the content of Chlorine (Cl) and Bromine (Br) based flame retardants meet JS709B low halogen requirements of <=1000ppm threshold. Antimony trioxide based flame retardants must also meet the <=1000ppm threshold requirement.

(3) MSL, Peak Temp. - The Moisture Sensitivity Level rating according to the JEDEC industry standard classifications, and peak solder temperature.

(4) There may be additional marking, which relates to the logo, the lot trace code information, or the environmental category on the device.

(5) Multiple Device Markings will be inside parentheses. Only one Device Marking contained in parentheses and separated by a "~" will appear on a device. If a line is indented then it is a continuation of the previous line and the two combined represent the entire Device Marking for that device.

(6) Lead finish/Ball material - Orderable Devices may have multiple material finish options. Finish options are separated by a vertical ruled line. Lead finish/Ball material values may wrap to two lines if the finish value exceeds the maximum column width.

**Important Information and Disclaimer:** The information provided on this page represents TI's knowledge and belief as of the date that it is provided. TI bases its knowledge and belief on information provided by third parties, and makes no representation or warranty as to the accuracy of such information. Efforts are underway to better integrate information from third parties. TI has taken and continues to take reasonable steps to provide representative and accurate information but may not have conducted destructive testing or chemical analysis on incoming materials and chemicals. TI and TI suppliers consider certain information to be proprietary, and thus CAS numbers and other limited information may not be available for release.

In no event shall TI's liability arising out of such information exceed the total purchase price of the TI part(s) at issue in this document sold by TI to Customer on an annual basis.

**TAPE AND REEL INFORMATION**

**QUADRANT ASSIGNMENTS FOR PIN 1 ORIENTATION IN TAPE**

\*All dimensions are nominal

Device	Package Type	Package Drawing	Pins	SPQ	Reel Diameter (mm)	Reel Width W1 (mm)	A0 (mm)	B0 (mm)	K0 (mm)	P1 (mm)	W (mm)	Pin1 Quadrant
SN74LV157ADBR	SSOP	DB	16	2000	330.0	16.4	8.35	6.6	2.4	12.0	16.0	Q1
SN74LV157ADGVR	TVSOP	DGV	16	2000	330.0	12.4	6.8	4.0	1.6	8.0	12.0	Q1
SN74LV157ADR	SOIC	D	16	2500	330.0	12.4	3.75	3.75	1.15	8.0	12.0	Q1
SN74LV157ADR	SOIC	D	16	2500	330.0	16.4	6.5	10.3	2.1	8.0	16.0	Q1
SN74LV157ADR	SOIC	D	16	2500	330.0	16.4	6.5	10.3	2.1	8.0	16.0	Q1
SN74LV157ANSR	SO	NS	16	2000	330.0	16.4	8.2	10.5	2.5	12.0	16.0	Q1
SN74LV157APWR	TSSOP	PW	16	2000	330.0	12.4	6.9	5.6	1.6	8.0	12.0	Q1
SN74LV157APWR	TSSOP	PW	16	2000	330.0	12.4	6.9	5.6	1.6	8.0	12.0	Q1
SN74LV157APWR	TSSOP	PW	16	2000	330.0	12.4	6.85	5.45	1.6	8.0	12.0	Q1

**TAPE AND REEL BOX DIMENSIONS**

\*All dimensions are nominal

Device	Package Type	Package Drawing	Pins	SPQ	Length (mm)	Width (mm)	Height (mm)
SN74LV157ADBR	SSOP	DB	16	2000	356.0	356.0	35.0
SN74LV157ADGVR	TVSOP	DGV	16	2000	356.0	356.0	35.0
SN74LV157ADR	SOIC	D	16	2500	340.5	336.1	32.0
SN74LV157ADR	SOIC	D	16	2500	356.0	356.0	35.0
SN74LV157ADR	SOIC	D	16	2500	340.5	336.1	32.0
SN74LV157ANSR	SO	NS	16	2000	356.0	356.0	35.0
SN74LV157APWR	TSSOP	PW	16	2000	356.0	356.0	35.0
SN74LV157APWR	TSSOP	PW	16	2000	356.0	356.0	35.0
SN74LV157APWR	TSSOP	PW	16	2000	366.0	364.0	50.0





# PACKAGE OUTLINE

## NS0016A

### SOP - 2.00 mm max height

SOP



4220735/A 12/2021

#### NOTES:

1. All linear dimensions are in millimeters. Dimensions in parenthesis are for reference only. Dimensioning and tolerancing per ASME Y14.5M.
2. This drawing is subject to change without notice.
3. This dimension does not include mold flash, protrusions, or gate burrs. Mold flash, protrusions, or gate burrs shall not exceed 0.15 mm, per side.
4. This dimension does not include interlead flash. Interlead flash shall not exceed 0.25 mm, per side.

# EXAMPLE BOARD LAYOUT

NS0016A

SOP - 2.00 mm max height

SOP



4220735/A 12/2021

NOTES: (continued)

5. Publication IPC-7351 may have alternate designs.

6. Solder mask tolerances between and around signal pads can vary based on board fabrication site.

# EXAMPLE STENCIL DESIGN

NS0016A

SOP - 2.00 mm max height

SOP



SOLDER PASTE EXAMPLE  
BASED ON 0.125 mm THICK STENCIL  
SCALE:7X

4220735/A 12/2021

NOTES: (continued)

7. Laser cutting apertures with trapezoidal walls and rounded corners may offer better paste release. IPC-7525 may have alternate design recommendations.
8. Board assembly site may have different recommendations for stencil design.

D (R-PDSO-G16)

PLASTIC SMALL OUTLINE



- NOTES:
- A. All linear dimensions are in inches (millimeters).
  - B. This drawing is subject to change without notice.
  - C. Body length does not include mold flash, protrusions, or gate burrs. Mold flash, protrusions, or gate burrs shall not exceed 0.006 (0,15) each side.
  - D. Body width does not include interlead flash. Interlead flash shall not exceed 0.017 (0,43) each side.
  - E. Reference JEDEC MS-012 variation AC.



4220204/A 02/2017

**NOTES:**

1. All linear dimensions are in millimeters. Any dimensions in parenthesis are for reference only. Dimensioning and tolerancing per ASME Y14.5M.
2. This drawing is subject to change without notice.
3. This dimension does not include mold flash, protrusions, or gate burrs. Mold flash, protrusions, or gate burrs shall not exceed 0.15 mm per side.
4. This dimension does not include interlead flash. Interlead flash shall not exceed 0.25 mm per side.
5. Reference JEDEC registration MO-153.

# EXAMPLE BOARD LAYOUT

PW0016A

TSSOP - 1.2 mm max height

SMALL OUTLINE PACKAGE



LAND PATTERN EXAMPLE  
EXPOSED METAL SHOWN  
SCALE: 10X



4220204/A 02/2017

NOTES: (continued)

- 6. Publication IPC-7351 may have alternate designs.
- 7. Solder mask tolerances between and around signal pads can vary based on board fabrication site.

# EXAMPLE STENCIL DESIGN

PW0016A

TSSOP - 1.2 mm max height

SMALL OUTLINE PACKAGE



SOLDER PASTE EXAMPLE  
BASED ON 0.125 mm THICK STENCIL  
SCALE: 10X

4220204/A 02/2017

NOTES: (continued)

8. Laser cutting apertures with trapezoidal walls and rounded corners may offer better paste release. IPC-7525 may have alternate design recommendations.
9. Board assembly site may have different recommendations for stencil design.

# DB0016A



# PACKAGE OUTLINE

## SSOP - 2 mm max height

SMALL OUTLINE PACKAGE



4220763/A 05/2022

**NOTES:**

1. All linear dimensions are in millimeters. Any dimensions in parenthesis are for reference only. Dimensioning and tolerancing per ASME Y14.5M.
2. This drawing is subject to change without notice.
3. This dimension does not include mold flash, protrusions, or gate burrs. Mold flash, protrusions, or gate burrs shall not exceed 0.15 mm per side.
4. Reference JEDEC registration MO-150.



# EXAMPLE BOARD LAYOUT

DB0016A

SSOP - 2 mm max height

SMALL OUTLINE PACKAGE



LAND PATTERN EXAMPLE  
EXPOSED METAL SHOWN  
SCALE: 10X



4220763/A 05/2022

NOTES: (continued)

- 5. Publication IPC-7351 may have alternate designs.
- 6. Solder mask tolerances between and around signal pads can vary based on board fabrication site.

# EXAMPLE STENCIL DESIGN

DB0016A

SSOP - 2 mm max height

SMALL OUTLINE PACKAGE



SOLDER PASTE EXAMPLE  
BASED ON 0.125 mm THICK STENCIL  
SCALE: 10X

4220763/A 05/2022

NOTES: (continued)

7. Laser cutting apertures with trapezoidal walls and rounded corners may offer better paste release. IPC-7525 may have alternate design recommendations.
8. Board assembly site may have different recommendations for stencil design.

# MECHANICAL DATA

NS (R-PDSO-G\*\*)

PLASTIC SMALL-OUTLINE PACKAGE

14-PINS SHOWN



- NOTES:
- A. All linear dimensions are in millimeters.
  - B. This drawing is subject to change without notice.
  - C. Body dimensions do not include mold flash or protrusion, not to exceed 0,15.

DGV (R-PDSO-G\*\*)

PLASTIC SMALL-OUTLINE

24 PINS SHOWN



- NOTES: A. All linear dimensions are in millimeters.  
 B. This drawing is subject to change without notice.  
 C. Body dimensions do not include mold flash or protrusion, not to exceed 0,15 per side.  
 D. Falls within JEDEC: 24/48 Pins – MO-153  
 14/16/20/56 Pins – MO-194

## 重要なお知らせと免責事項

TI は、技術データと信頼性データ (データシートを含みます)、設計リソース (リファレンス・デザインを含みます)、アプリケーションや設計に関する各種アドバイス、Web ツール、安全性情報、その他のリソースを、欠陥が存在する可能性のある「現状のまま」提供しており、商品性および特定目的に対する適合性の黙示保証、第三者の知的財産権の非侵害保証を含むいかなる保証も、明示的または黙示的にかかわらず拒否します。

これらのリソースは、TI 製品を使用する設計の経験を積んだ開発者への提供を意図したものです。(1) お客様のアプリケーションに適した TI 製品の選定、(2) お客様のアプリケーションの設計、検証、試験、(3) お客様のアプリケーションに該当する各種規格や、その他のあらゆる安全性、セキュリティ、規制、または他の要件への確実な適合に関する責任を、お客様のみが単独で負うものとし、

上記の各種リソースは、予告なく変更される可能性があります。これらのリソースは、リソースで説明されている TI 製品を使用するアプリケーションの開発の目的でのみ、TI はその使用をお客様に許諾します。これらのリソースに関して、他の目的で複製することや掲載することは禁止されています。TI や第三者の知的財産権のライセンスが付与されている訳ではありません。お客様は、これらのリソースを自身で使用した結果発生するあらゆる申し立て、損害、費用、損失、責任について、TI およびその代理人を完全に補償するものとし、TI は一切の責任を拒否します。

TI の製品は、[TI の販売条件](#)、または [ti.com](#) やかかる TI 製品の関連資料などのいずれかを通じて提供する適用可能な条項の下で提供されています。TI がこれらのリソースを提供することは、適用される TI の保証または他の保証の放棄の拡大や変更を意味するものではありません。

お客様がいかなる追加条項または代替条項を提案した場合でも、TI はそれらに異議を唱え、拒否します。

郵送先住所 : Texas Instruments, Post Office Box 655303, Dallas, Texas 75265  
Copyright © 2024, Texas Instruments Incorporated