

## SN74LVC1G66-Q1 Single Bilateral Analog Switch

### 1 Features

- Qualified for Automotive Applications
- AEC-Q100 Qualified With the Following Results:
  - Device Temperature Grade 1:  $-40^{\circ}\text{C}$  to  $125^{\circ}\text{C}$  Ambient Operating Temperature Range
  - Device HBM Classification Level H2
  - Device CDM Classification Level C5
  - Device MM Classification Level M3
- 1.65-V to 5.5-V  $V_{\text{CC}}$  Operation
- Inputs Accept Voltages to 5.5 V
- Max  $t_{\text{pd}}$  of 0.8 ns at 3.3 V
- High On-Off Output Voltage Ratio
- High Degree of Linearity
- High Speed, Typically 0.5 ns ( $V_{\text{CC}} = 3\text{ V}$ ,  $C_{\text{L}} = 50\text{ pF}$ )
- Low ON-State Resistance, Typically  $\approx 5.5\ \Omega$  ( $V_{\text{CC}} = 4.5\text{ V}$ )
- Latch-Up Performance Exceeds 100 mA Per JESD 78, Class II

### 2 Applications

- Infotainment Systems
- Wireless Devices
- Audio and Video Signal Routing
- Portable Computing
- Wearable Devices
- Signal Gating, Chopping, Modulation or Demodulation (Modem)
- Signal Multiplexing for Analog-to-Digital and Digital-to-Analog Conversion Systems

### 3 Description

This single analog switch is designed for 1.65-V to 5.5-V  $V_{\text{CC}}$  operation.

The SN74LVC1G66-Q1 device supports analog and digital signals. The device permits bidirectional transmission of signals with amplitudes of up to 5.5 V (peak).

#### Device Information<sup>(1)</sup>

PART NUMBER	PACKAGE	BODY SIZE (NOM)
SN74LVC1G66-Q1	SOT-23 (5)	2.90 mm x 1.60 mm
	SC70 (5)	1.60 mm x 1.20 mm

(1) For all available packages, see the orderable addendum at the end of the datasheet.

#### Logic Diagram (Positive Logic)

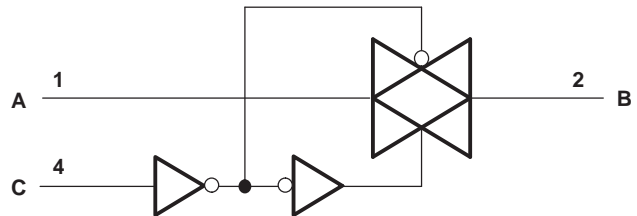

## Table of Contents

<b>1 Features</b> .....	<b>1</b>	8.1 Overview .....	<b>12</b>
<b>2 Applications</b> .....	<b>1</b>	8.2 Functional Block Diagram .....	<b>12</b>
<b>3 Description</b> .....	<b>1</b>	8.3 Feature Description .....	<b>12</b>
<b>4 Revision History</b> .....	<b>2</b>	8.4 Device Functional Modes .....	<b>12</b>
<b>5 Pin Configuration and Functions</b> .....	<b>3</b>	<b>9 Application and Implementation</b> .....	<b>13</b>
<b>6 Specifications</b> .....	<b>4</b>	9.1 Application Information .....	<b>13</b>
6.1 Absolute Maximum Ratings .....	<b>4</b>	9.2 Typical Application .....	<b>13</b>
6.2 ESD Ratings .....	<b>4</b>	<b>10 Power Supply Recommendations</b> .....	<b>14</b>
6.3 Recommended Operating Conditions .....	<b>4</b>	<b>11 Layout</b> .....	<b>14</b>
6.4 Thermal Information .....	<b>5</b>	11.1 Layout Guidelines .....	<b>14</b>
6.5 Electrical Characteristics .....	<b>5</b>	11.2 Layout Example .....	<b>15</b>
6.6 Switching Characteristics .....	<b>5</b>	<b>12 Device and Documentation Support</b> .....	<b>15</b>
6.7 Analog Switch Characteristics .....	<b>6</b>	12.1 Documentation Support .....	<b>15</b>
6.8 Operating Characteristics .....	<b>6</b>	12.2 Trademarks .....	<b>15</b>
6.9 Typical Characteristics .....	<b>7</b>	12.3 Electrostatic Discharge Caution .....	<b>15</b>
<b>7 Parameter Measurement Information</b> .....	<b>8</b>	12.4 Glossary .....	<b>15</b>
<b>8 Detailed Description</b> .....	<b>12</b>	<b>13 Mechanical, Packaging, and Orderable Information</b> .....	<b>15</b>

## 4 Revision History

### Changes from Revision D (January 2008) to Revision E

Page

- Added *Device Information* and *ESD Ratings* tables and the following sections: *Pin Configurations and Functions*, *Detailed Description*, *Application and Implementation*, *Power Supply Recommendations*, *Layout*, *Device and Documentation Support*, and *Mechanical, Packaging, and Orderable Information*..... **1**

## 5 Pin Configuration and Functions

**DBV and DCK Packages  
5-Pin SOT-23 and SC70  
Top View**

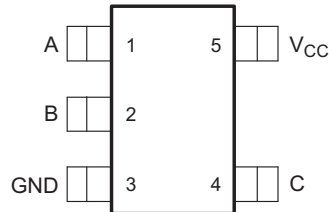

**Pin Functions**

PIN		I/O	DESCRIPTION
NAME	NO.		
A	1	I/O	Bidirectional signal to be switched
B	2	I/O	Bidirectional signal to be switched
C	4	I	Controls the switch (L = OFF, H = ON)
GND	3	—	Ground pin
V <sub>CC</sub>	5	—	Power pin

## 6 Specifications

### 6.1 Absolute Maximum Ratings

 over operating free-air temperature range (unless otherwise noted)<sup>(1)</sup>

		MIN	MAX	UNIT
V <sub>CC</sub>	Supply voltage <sup>(2)</sup>	-0.5	6.5	V
V <sub>I</sub>	Input voltage <sup>(2)(3)</sup>	-0.5	6.5	V
V <sub>I/O</sub>	Switch I/O voltage <sup>(2)(3)(4)</sup>	-0.5	V <sub>CC</sub> + 0.5	V
I <sub>IK</sub>	Control input clamp current	V <sub>I</sub> < 0	-50	mA
I <sub>I/O</sub>	I/O port diode current	V <sub>I/O</sub> < 0	-50	mA
I <sub>T</sub>	ON-state switch current	V <sub>I/O</sub> < 0 to V <sub>CC</sub>	±50	mA
	Continuous current through V <sub>CC</sub> or GND		±100	mA
T <sub>stg</sub>	Storage temperature	-65	150	°C

- (1) Stresses beyond those listed under *Absolute Maximum Ratings* may cause permanent damage to the device. These are stress ratings only, and functional operation of the device at these or any other conditions beyond those indicated under *Recommended Operating Conditions* is not implied. Exposure to absolute-maximum-rated conditions for extended periods may affect device reliability.
- (2) All voltages are with respect to ground, unless otherwise specified.
- (3) The input and output negative-voltage ratings may be exceeded if the input and output clamp-current ratings are observed.
- (4) This value is limited to 5.5 V maximum.

### 6.2 ESD Ratings

		VALUE	UNIT
V <sub>(ESD)</sub>	Electrostatic discharge	Human-body model (HBM), per AEC Q100-002 <sup>(1)</sup>	2000
		Charged-device model (CDM), per AEC Q100-011	1000

- (1) AEC Q100-002 indicates that HBM stressing shall be in accordance with the ANSI/ESDA/JEDEC JS-001 specification.

### 6.3 Recommended Operating Conditions

 over operating free-air temperature range (unless otherwise noted)<sup>(1)</sup>

		MIN	MAX	UNIT
V <sub>CC</sub>	Supply voltage	1.65	5.5	V
V <sub>I/O</sub>	I/O port voltage	0	V <sub>CC</sub>	V
V <sub>IH</sub>	High-level input voltage, control input	V <sub>CC</sub> = 1.65 V to 1.95 V	V <sub>CC</sub> × 0.65	V
		V <sub>CC</sub> = 2.3 V to 2.7 V	V <sub>CC</sub> × 0.7	
		V <sub>CC</sub> = 3 V to 3.6 V	V <sub>CC</sub> × 0.7	
		V <sub>CC</sub> = 4.5 V to 5.5 V	V <sub>CC</sub> × 0.7	
V <sub>IL</sub>	Low-level input voltage, control input	V <sub>CC</sub> = 1.65 V to 1.95 V	V <sub>CC</sub> × 0.35	V
		V <sub>CC</sub> = 2.3 V to 2.7 V	V <sub>CC</sub> × 0.3	
		V <sub>CC</sub> = 3 V to 3.6 V	V <sub>CC</sub> × 0.3	
		V <sub>CC</sub> = 4.5 V to 5.5 V	V <sub>CC</sub> × 0.3	
V <sub>I</sub>	Control input voltage	0	5.5	V
Δt/Δv	Input transition rise and fall time	V <sub>CC</sub> = 1.65 V to 1.95 V	20	ns/V
		V <sub>CC</sub> = 2.3 V to 2.7 V	20	
		V <sub>CC</sub> = 3 V to 3.6 V	10	
		V <sub>CC</sub> = 4.5 V to 5.5 V	10	
T <sub>A</sub>	Operating free-air temperature	-40	125	°C

- (1) All unused inputs of the device must be held at V<sub>CC</sub> or GND to ensure proper device operation. Refer to the TI application report, *Implications of Slow or Floating CMOS Inputs*, [SCBA004](#).

## 6.4 Thermal Information

THERMAL METRIC <sup>(1)</sup>	SN74LVC1G66-Q1		UNIT
	DBV (SOT-23)	DCK (SC70)	
	5 PINS	5 PINS	
R <sub>θJA</sub> Junction-to-ambient thermal resistance	206	252	°C/W

(1) For more information about traditional and new thermal metrics, see the *Semiconductor and IC Package Thermal Metrics* application report, [SPRA953](#).

## 6.5 Electrical Characteristics

over recommended operating free-air temperature range (unless otherwise noted)

PARAMETER	TEST CONDITIONS	V <sub>CC</sub>	MIN	TYP <sup>(1)</sup>	MAX	UNIT
r <sub>on</sub> ON-state switch resistance	V <sub>I</sub> = V <sub>CC</sub> or GND, V <sub>C</sub> = V <sub>IH</sub> (see <a href="#">Figure 2</a> and <a href="#">Figure 1</a> )	I <sub>S</sub> = 4 mA	1.65 V	12	35	Ω
		I <sub>S</sub> = 8 mA	2.3 V	9	30	
		I <sub>S</sub> = 16 mA	3 V	9	30	
		I <sub>S</sub> = 16 mA	4.5 V	5.5	25	
r <sub>on(p)</sub> Peak on resistance	V <sub>I</sub> = V <sub>CC</sub> or GND, V <sub>C</sub> = V <sub>IH</sub> (see <a href="#">Figure 2</a> and <a href="#">Figure 1</a> )	I <sub>S</sub> = 4 mA	1.65 V	74.5	165	Ω
		I <sub>S</sub> = 8 mA	2.3 V	20	60	
		I <sub>S</sub> = 16 mA	3 V	12.5	35	
		I <sub>S</sub> = 16 mA	4.5 V	7.5	25	
I <sub>S(off)</sub> OFF-state switch leakage current	V <sub>I</sub> = V <sub>CC</sub> and V <sub>O</sub> = GND or V <sub>I</sub> = GND and V <sub>O</sub> = V <sub>CC</sub> , V <sub>C</sub> = V <sub>IL</sub> (see <a href="#">Figure 3</a> )	5.5 V		±1	±0.1 <sup>(1)</sup>	μA
I <sub>S(on)</sub> ON-state switch leakage current	V <sub>I</sub> = V <sub>CC</sub> or GND, V <sub>C</sub> = V <sub>IH</sub> , V <sub>O</sub> = Open (see <a href="#">Figure 4</a> )	5.5 V		±1	±0.1 <sup>(1)</sup>	μA
I <sub>I</sub> Control input current	V <sub>C</sub> = V <sub>CC</sub> or GND	5.5 V		±1	±0.1 <sup>(1)</sup>	μA
I <sub>CC</sub> Supply current	V <sub>C</sub> = V <sub>CC</sub> or GND	5.5 V		10	1 <sup>(1)</sup>	μA
ΔI <sub>CC</sub> Supply current change	V <sub>C</sub> = V <sub>CC</sub> – 0.6 V	5.5 V			500	μA
C <sub>ic</sub> Control input capacitance		5 V		2		pF
C <sub>io(off)</sub> Switch input and output capacitance		5 V		6		pF
C <sub>io(on)</sub> Switch input and output capacitance		5 V		13		pF

(1) T<sub>A</sub> = 25°C

## 6.6 Switching Characteristics

over recommended operating free-air temperature range (unless otherwise noted) (see [Figure 5](#))

PARAMETER	FROM (INPUT)	TO (OUTPUT)	V <sub>CC</sub> = 1.8 V ± 0.15 V		V <sub>CC</sub> = 2.5 V ± 0.2 V		V <sub>CC</sub> = 3.3 V ± 0.3 V		V <sub>CC</sub> = 5 V ± 0.5 V		UNIT
			MIN	MAX	MIN	MAX	MIN	MAX	MIN	MAX	
t <sub>pd</sub> <sup>(1)</sup> Propagation delay	A or B	B or A	5.5		3.2		2.8		2.6		ns
t <sub>en</sub> <sup>(2)</sup> Enable time	C	A or B	2.5	14	1.9	9.5	1.8	8	1.5	7.2	ns
t <sub>dis</sub> <sup>(3)</sup> Disable time	C	A or B	2.2	12	1.4	8.9	2	8.4	1.4	6.9	ns

(1) t<sub>PLH</sub> and t<sub>PHL</sub> are the same as t<sub>pd</sub>. The propagation delay is the calculated RC time constant of the typical ON-state resistance of the switch and the specified load capacitance, when driven by an ideal voltage source (zero output impedance).

(2) t<sub>PZL</sub> and t<sub>PZH</sub> are the same as t<sub>en</sub>.

(3) t<sub>PLZ</sub> and t<sub>PHZ</sub> are the same as t<sub>dis</sub>.

## 6.7 Analog Switch Characteristics

 $T_A = 25^\circ\text{C}$ 

PARAMETER	FROM (INPUT)	TO (OUTPUT)	TEST CONDITIONS	$V_{CC}$	TYP	UNIT
Frequency response <sup>(1)</sup> (switch ON)	A or B	B or A	$C_L = 50\text{ pF}$ , $R_L = 600\ \Omega$ , $f_{in} = \text{sine wave}$ (see Figure 6)	1.65 V	35	MHz
				2.3 V	120	
				3 V	175	
				4.5 V	195	
			$C_L = 5\text{ pF}$ , $R_L = 50\ \Omega$ , $f_{in} = \text{sine wave}$ (see Figure 6)	1.65 V	>300	
				2.3 V	>300	
				3 V	>300	
				4.5 V	>300	
Crosstalk (control input to signal output)	C	A or B	$C_L = 50\text{ pF}$ , $R_L = 600\ \Omega$ , $f_{in} = 1\text{ MHz}$ (square wave) (see Figure 7)	1.65 V	35	mV
				2.3 V	50	
				3 V	70	
				4.5 V	100	
Feedthrough attenuation <sup>(2)</sup> (switch OFF)	A or B	B or A	$C_L = 50\text{ pF}$ , $R_L = 600\ \Omega$ , $f_{in} = 1\text{ MHz}$ (sine wave) (see Figure 8)	1.65 V	-58	dB
				2.3 V	-58	
				3 V	-58	
				4.5 V	-58	
			$C_L = 5\text{ pF}$ , $R_L = 50\ \Omega$ , $f_{in} = 1\text{ MHz}$ (sine wave) (see Figure 8)	1.65 V	-42	
				2.3 V	-42	
				3 V	-42	
				4.5 V	-42	
Sine-wave distortion	A or B	B or A	$C_L = 50\text{ pF}$ , $R_L = 10\text{ k}\Omega$ , $f_{in} = 1\text{ kHz}$ (sine wave) (see Figure 9)	1.65 V	0.1%	
				2.3 V	0.025%	
				3 V	0.015%	
				4.5 V	0.01%	
			$C_L = 50\text{ pF}$ , $R_L = 10\text{ k}\Omega$ , $f_{in} = 10\text{ kHz}$ (sine wave) (see Figure 9)	1.65 V	0.15%	
				2.3 V	0.025%	
				3 V	0.015%	
				4.5 V	0.01%	

(1) Adjust  $f_{in}$  voltage to obtain 0 dBm at output. Increase  $f_{in}$  frequency until dB meter reads -3 dB.

(2) Adjust  $f_{in}$  voltage to obtain 0 dBm at input.

## 6.8 Operating Characteristics

 $T_A = 25^\circ\text{C}$ 

PARAMETER	TEST CONDITIONS	$V_{CC} = 1.8\text{ V}$	$V_{CC} = 2.5\text{ V}$	$V_{CC} = 3.3\text{ V}$	$V_{CC} = 5\text{ V}$	UNIT
		TYP	TYP	TYP	TYP	
$C_{pd}$ Power dissipation capacitance	$f = 10\text{ MHz}$	8	9	9	11	pF

### 6.9 Typical Characteristics

$T_A = 25^\circ\text{C}$

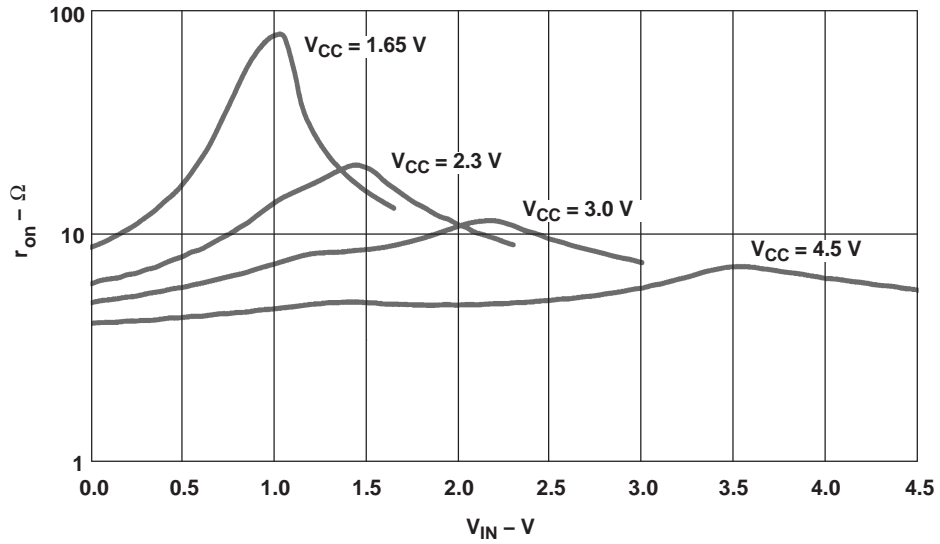

Figure 1. Typical  $r_{on}$  as a Function of Input Voltage ( $V_I$ ) for  $V_I = 0$  to  $V_{CC}$

## 7 Parameter Measurement Information

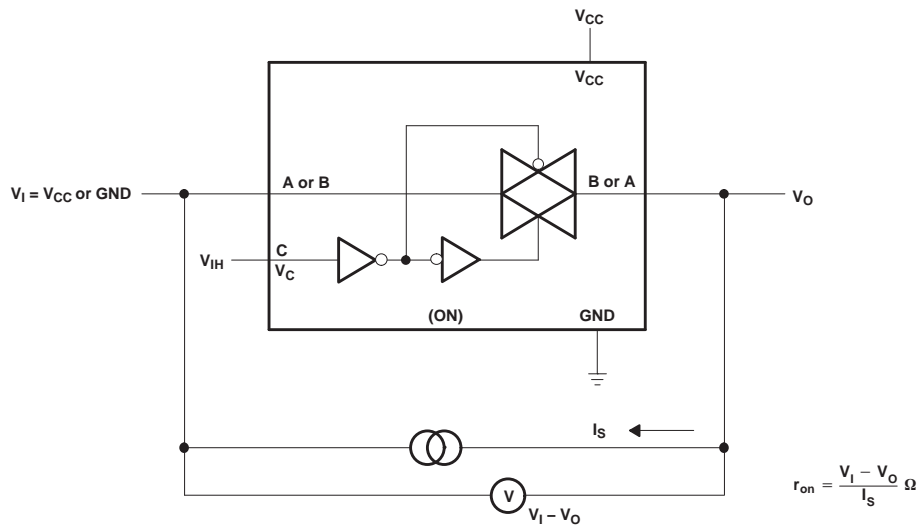

Figure 2. ON-State Resistance Test Circuit

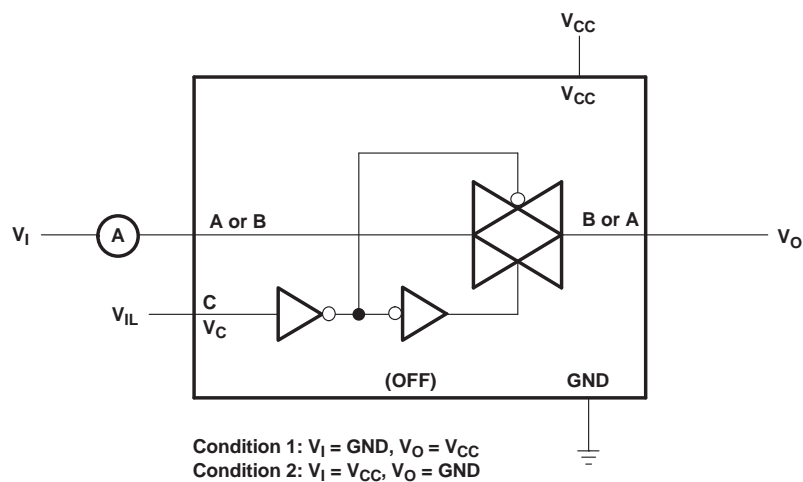

Figure 3. OFF-State Switch Leakage-Current Test Circuit

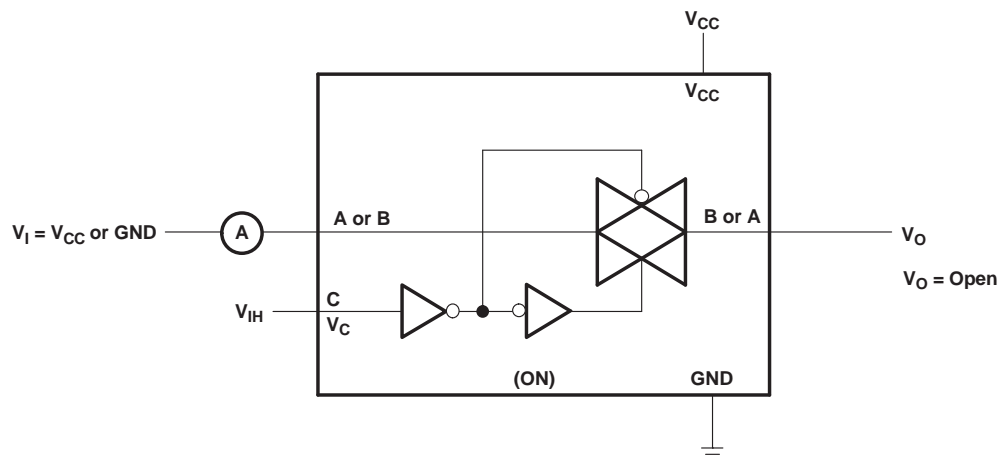
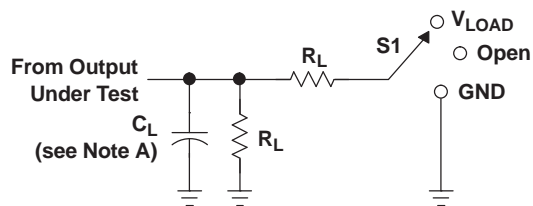

Figure 4. ON-State Switch Leakage-Current Test Circuit



Parameter Measurement Information (continued)



LOAD CIRCUIT

TEST	S1
$t_{PLH}/t_{PHL}$	Open
$t_{PLZ}/t_{PZL}$	$V_{LOAD}$
$t_{PHZ}/t_{PZH}$	GND

$V_{CC}$	INPUTS		$V_M$	$V_{LOAD}$	$C_L$	$R_L$	$V_{\Delta}$
	$V_I$	$t_r/t_f$					
$1.8\text{ V} \pm 0.15\text{ V}$	$V_{CC}$	$\leq 2\text{ ns}$	$V_{CC}/2$	$2 \times V_{CC}$	30 pF	1 k $\Omega$	0.15 V
$2.5\text{ V} \pm 0.2\text{ V}$	$V_{CC}$	$\leq 2\text{ ns}$	$V_{CC}/2$	$2 \times V_{CC}$	30 pF	500 $\Omega$	0.15 V
$3.3\text{ V} \pm 0.3\text{ V}$	$V_{CC}$	$\leq 2.5\text{ ns}$	$V_{CC}/2$	$2 \times V_{CC}$	50 pF	500 $\Omega$	0.3 V
$5\text{ V} \pm 0.5\text{ V}$	$V_{CC}$	$\leq 2.5\text{ ns}$	$V_{CC}/2$	$2 \times V_{CC}$	50 pF	500 $\Omega$	0.3 V

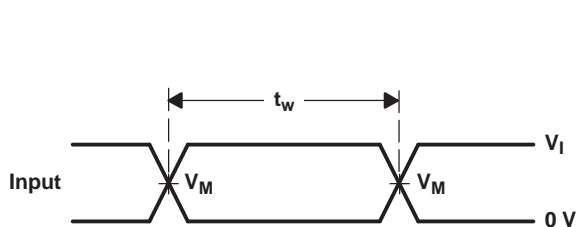

VOLTAGE WAVEFORMS PULSE DURATION

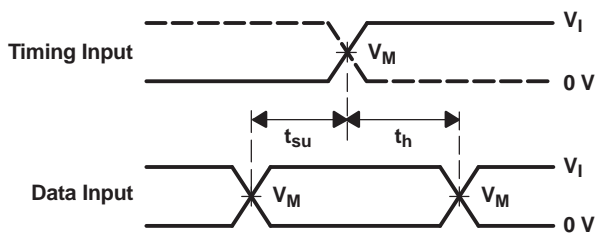

VOLTAGE WAVEFORMS SETUP AND HOLD TIMES

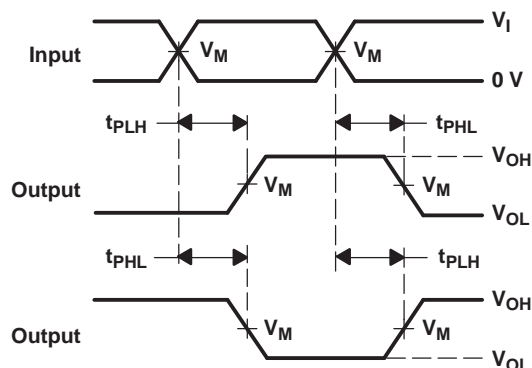

VOLTAGE WAVEFORMS PROPAGATION DELAY TIMES INVERTING AND NONINVERTING OUTPUTS

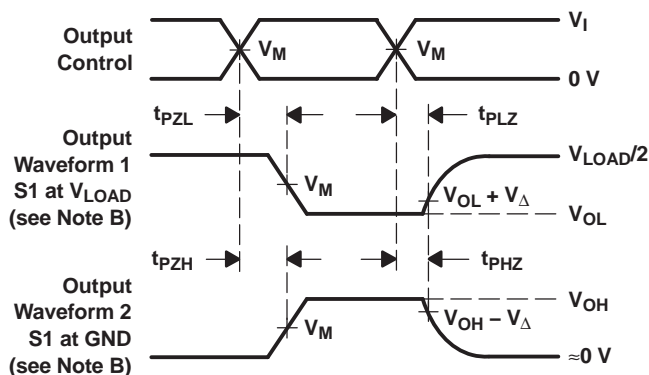

VOLTAGE WAVEFORMS ENABLE AND DISABLE TIMES LOW- AND HIGH-LEVEL ENABLING

- NOTES:
- A.  $C_L$  includes probe and jig capacitance.
  - B. Waveform 1 is for an output with internal conditions such that the output is low, except when disabled by the output control. Waveform 2 is for an output with internal conditions such that the output is high, except when disabled by the output control.
  - C. All input pulses are supplied by generators having the following characteristics:  $PRR \leq 10\text{ MHz}$ ,  $Z_O = 50\ \Omega$ .
  - D. The outputs are measured one at a time, with one transition per measurement.
  - E.  $t_{PLZ}$  and  $t_{PHZ}$  are the same as  $t_{dis}$ .
  - F.  $t_{PZL}$  and  $t_{PZH}$  are the same as  $t_{en}$ .
  - G.  $t_{PLH}$  and  $t_{PHL}$  are the same as  $t_{pd}$ .
  - H. All parameters and waveforms are not applicable to all devices.

Figure 5. Load Circuit and Voltage Waveforms

Parameter Measurement Information (continued)

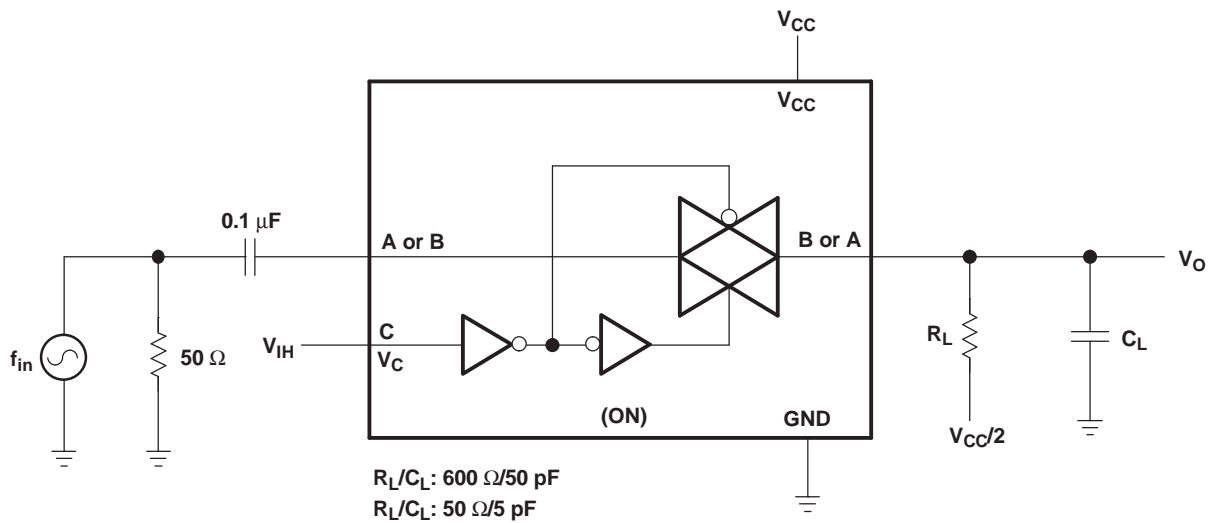

Figure 6. Frequency Response (Switch ON)

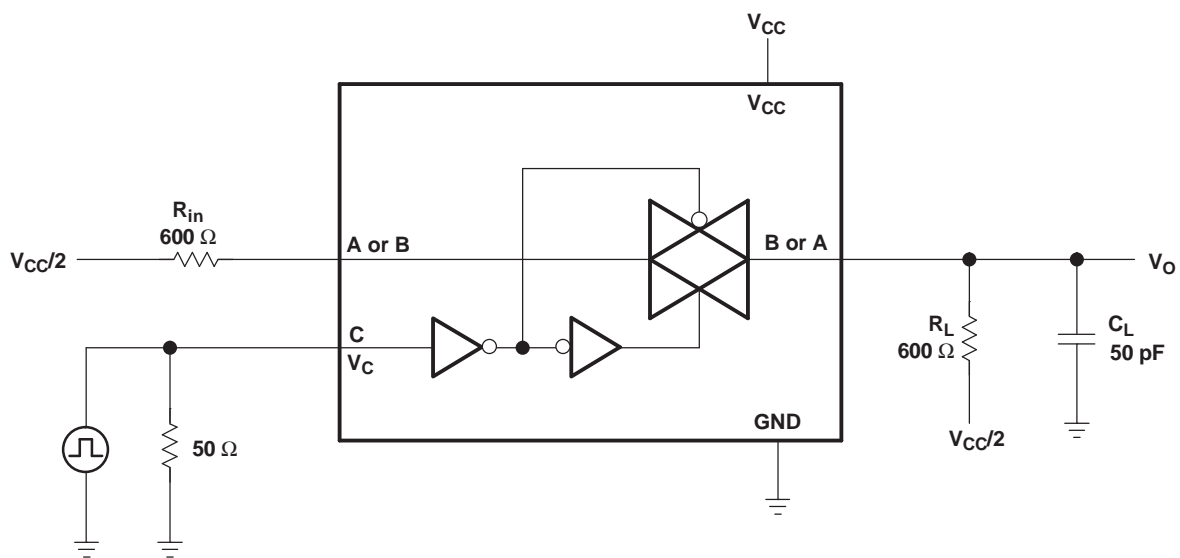

Figure 7. Crosstalk (Control Input – Switch Output)

Parameter Measurement Information (continued)

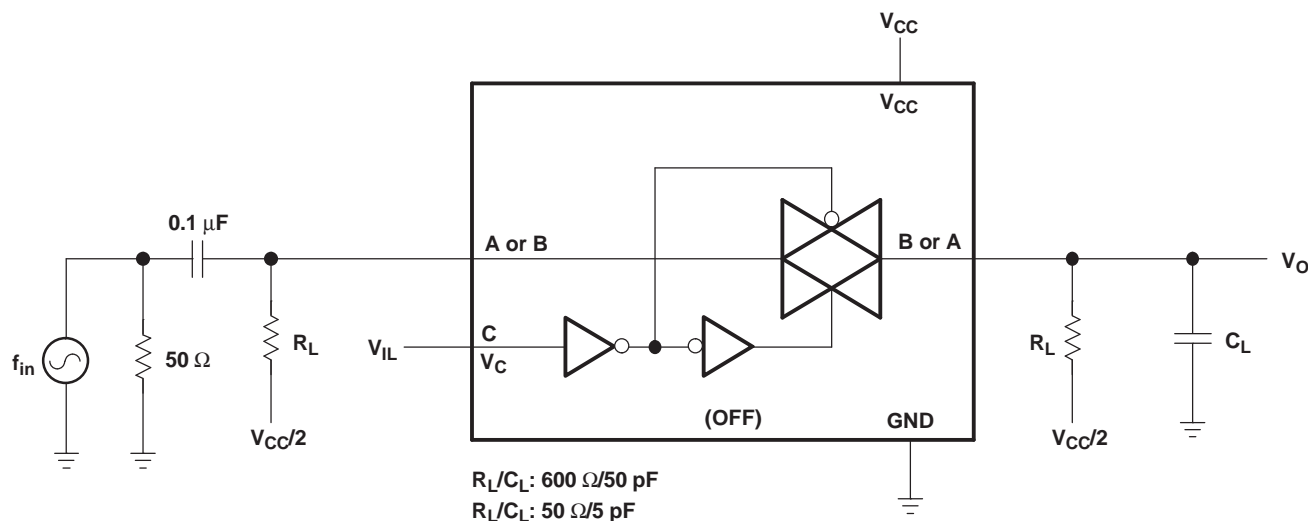

Figure 8. Feedthrough (Switch OFF)

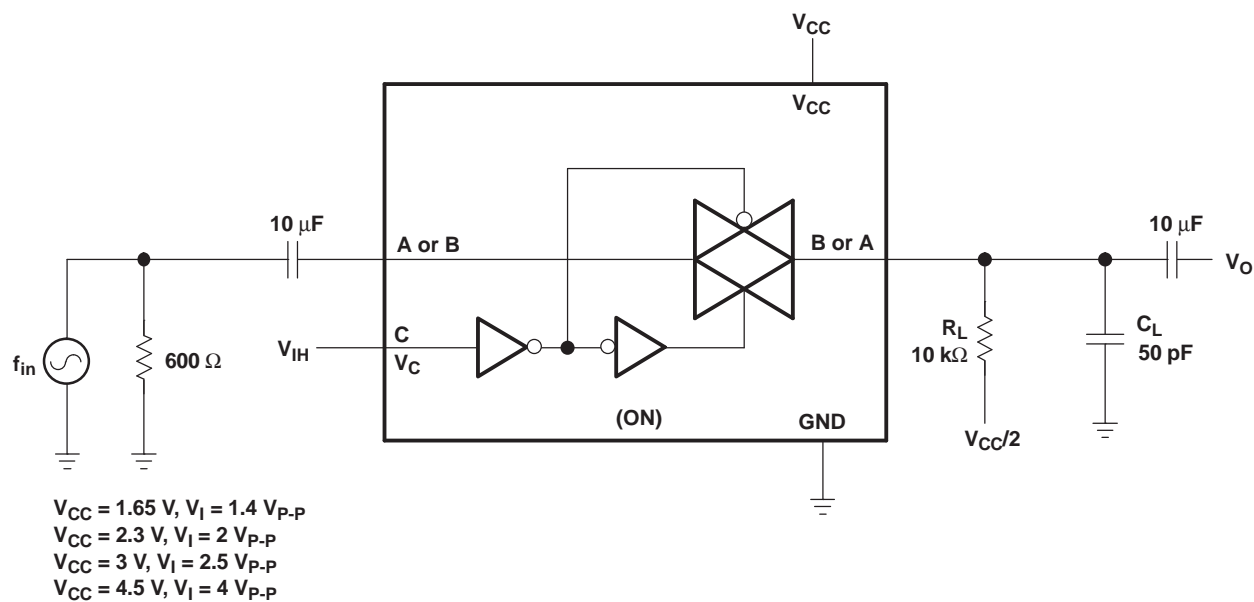

Figure 9. Sine-Wave Distortion

## 8 Detailed Description

### 8.1 Overview

This single analog switch is designed for 1.65-V to 5.5-V  $V_{CC}$  operation in automotive applications.

The SN74LVC1G66-Q1 device supports analog and digital signals. The device permits bidirectional transmission of signals with amplitudes of up to 5.5 V (peak). Like all analog switches, the SN74LVC1G66-Q1 is bidirectional.

### 8.2 Functional Block Diagram

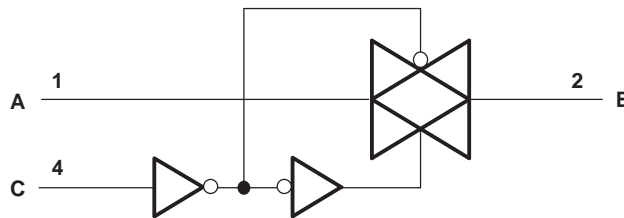

**Figure 10. Logic Diagram (Positive Logic)**

### 8.3 Feature Description

This device is tested for operation in automotive applications. The SN74LVC1G66-Q1 has a wide  $V_{CC}$  range, allowing rail-to-rail operation of signals anywhere from a 1.8-V system to a 5-V system. In addition, the control input (C Pin) is 5.5-V tolerant, allowing higher-voltage logic to interface to the switch control system.

### 8.4 Device Functional Modes

**Table 1. Function Table**

CONTROL INPUT (C)	SWITCH
L	OFF
H	ON

## 9 Application and Implementation

### NOTE

Information in the following applications sections is not part of the TI component specification, and TI does not warrant its accuracy or completeness. TI's customers are responsible for determining suitability of components for their purposes. Customers should validate and test their design implementation to confirm system functionality.

### 9.1 Application Information

The SN74LVC1G66-Q1 device can be used in any situation where an SPST switch would be used and a solid-state, voltage-controlled version is preferred.

### 9.2 Typical Application

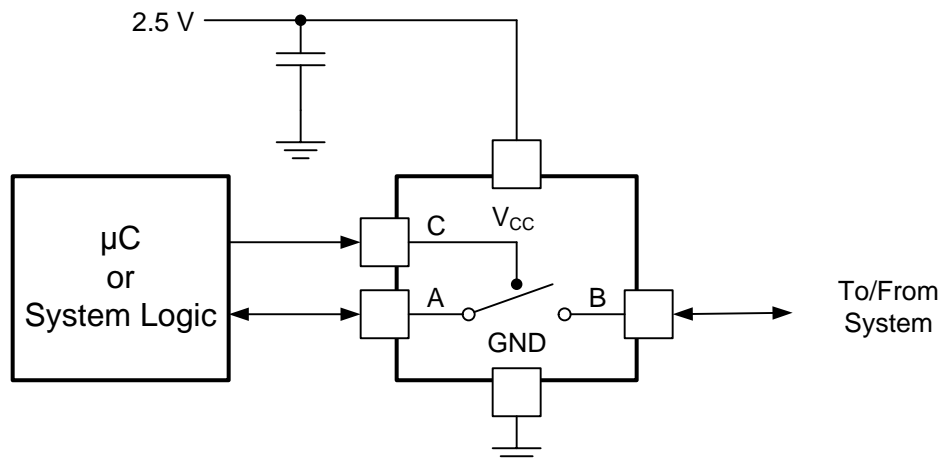

Figure 11. Typical Application Schematic

#### 9.2.1 Design Requirements

The SN74LVC1G66-Q1 device allows on and off control of analog and digital signals with a digital control signal. All input signals must be between 0 V and  $V_{CC}$  for optimal operation.

#### 9.2.2 Detailed Design Procedure

1. Recommended input conditions:
  - For rise time and fall time specifications, see  $\Delta t/\Delta v$  in the [Recommended Operating Conditions](#) table.
  - For specified high and low levels, see  $V_{IH}$  and  $V_{IL}$  in the [Recommended Operating Conditions](#) table.
  - Inputs and outputs are overvoltage tolerant and can therefore go as high as 5.5 V at any valid  $V_{CC}$ .
2. Recommended output conditions:
  - Load currents should not exceed  $\pm 50$  mA.
3. Frequency selection criterion:
  - Maximum frequency tested is 150 MHz.
  - Added trace resistance and capacitance can reduce maximum frequency capability; follow the layout practices listed in the [Layout](#) section.

## Typical Application (continued)

### 9.2.3 Application Curve

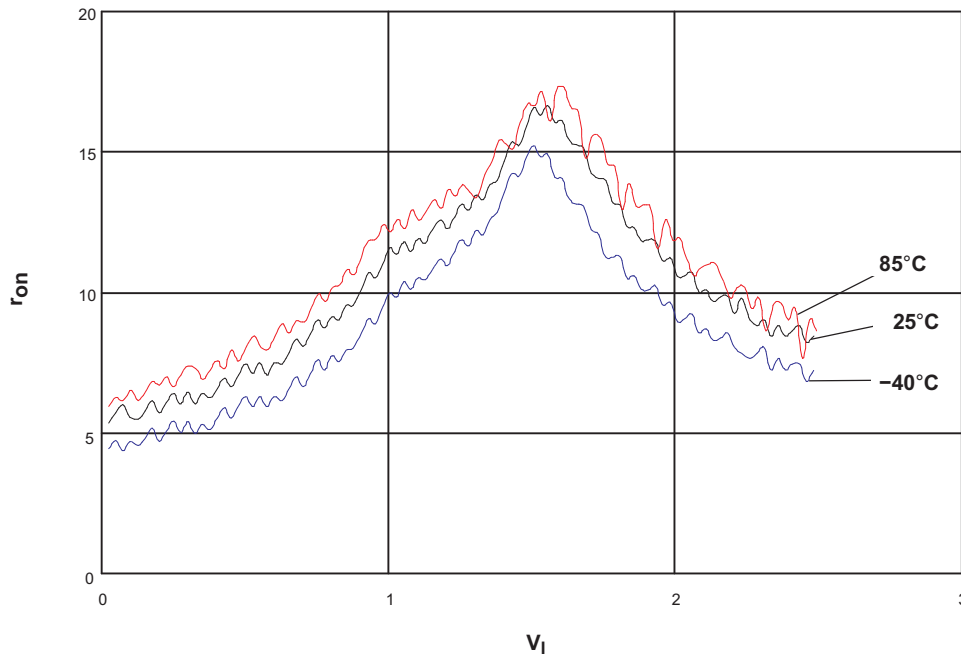

**Figure 12.**  $r_{on}$  vs  $V_I$ ,  $V_{CC} = 2.5$  V (SN74LVC1G66-Q1)

## 10 Power Supply Recommendations

The power supply can be any voltage between the minimum and maximum supply voltage rating listed in the [Recommended Operating Conditions](#) table.

Each  $V_{CC}$  terminal should have a good bypass capacitor to prevent power disturbance. For devices with a single supply, a 0.1- $\mu$ F bypass capacitor is recommended. If multiple pins are labeled  $V_{CC}$ , then a 0.01- $\mu$ F or 0.022- $\mu$ F capacitor is recommended for each  $V_{CC}$  because the  $V_{CC}$  pins are tied together internally. For devices with dual supply pins operating at different voltages, for example  $V_{CC}$  and  $V_{DD}$ , a 0.1- $\mu$ F bypass capacitor is recommended for each supply pin. To reject different frequencies of noise, use multiple bypass capacitors in parallel. Capacitors with values of 0.1  $\mu$ F and 1  $\mu$ F are commonly used in parallel. The bypass capacitor should be installed as close to the power terminal as possible for best results.

## 11 Layout

### 11.1 Layout Guidelines

Reflections and matching are closely related to the loop antenna theory but are different enough to be discussed separately from the theory. When a PCB trace turns a corner at a 90° angle, a reflection can occur. A reflection occurs primarily because of the change of width of the trace. At the apex of the turn, the trace width increases to 1.414 times the width. This increase upsets the transmission-line characteristics, especially the distributed capacitance and self-inductance of the trace which results in the reflection. Not all PCB traces can be straight and therefore some traces must turn corners. [Figure 13](#) shows progressively better techniques of rounding corners. Only the last example (BEST) maintains constant trace width and minimizes reflections.

## 11.2 Layout Example

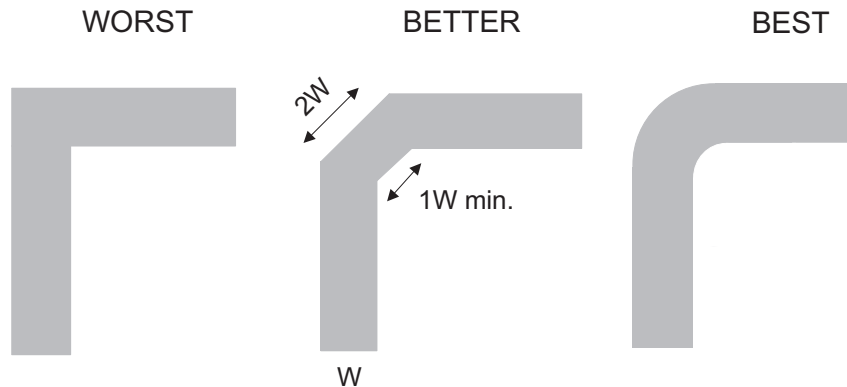

**Figure 13. Trace Example**

## 12 Device and Documentation Support

### 12.1 Documentation Support

#### 12.1.1 Related Documentation

For related documentation see the following:

- *Implications of Slow or Floating CMOS Inputs*, [SCBA004](#)
- *Selecting the Right Texas Instruments Signal Switch*, [SZZA030](#)

### 12.2 Trademarks

All trademarks are the property of their respective owners.

### 12.3 Electrostatic Discharge Caution



These devices have limited built-in ESD protection. The leads should be shorted together or the device placed in conductive foam during storage or handling to prevent electrostatic damage to the MOS gates.

### 12.4 Glossary

[SLYZ022](#) — *TI Glossary*.

This glossary lists and explains terms, acronyms, and definitions.

## 13 Mechanical, Packaging, and Orderable Information

The following pages include mechanical, packaging, and orderable information. This information is the most current data available for the designated devices. This data is subject to change without notice and revision of this document. For browser-based versions of this data sheet, refer to the left-hand navigation.

**PACKAGING INFORMATION**

Orderable Device	Status (1)	Package Type	Package Drawing	Pins	Package Qty	Eco Plan (2)	Lead finish/ Ball material (6)	MSL Peak Temp (3)	Op Temp (°C)	Device Marking (4/5)	Samples
1P1G66QDBVRG4Q1	LIFEBUY	SOT-23	DBV	5	3000	RoHS & Green	NIPDAU	Level-1-260C-UNLIM	-40 to 125	C66R	
1P1G66QDBVRQ1	ACTIVE	SOT-23	DBV	5	3000	RoHS & Green	NIPDAU	Level-1-260C-UNLIM	-40 to 125	C66R	Samples
SN74LVC1G66QDCKRQ1	ACTIVE	SC70	DCK	5	3000	RoHS & Green	NIPDAU	Level-1-260C-UNLIM	-40 to 125	C6O	Samples

(1) The marketing status values are defined as follows:

**ACTIVE:** Product device recommended for new designs.

**LIFEBUY:** TI has announced that the device will be discontinued, and a lifetime-buy period is in effect.

**NRND:** Not recommended for new designs. Device is in production to support existing customers, but TI does not recommend using this part in a new design.

**PREVIEW:** Device has been announced but is not in production. Samples may or may not be available.

**OBSOLETE:** TI has discontinued the production of the device.

(2) **RoHS:** TI defines "RoHS" to mean semiconductor products that are compliant with the current EU RoHS requirements for all 10 RoHS substances, including the requirement that RoHS substance do not exceed 0.1% by weight in homogeneous materials. Where designed to be soldered at high temperatures, "RoHS" products are suitable for use in specified lead-free processes. TI may reference these types of products as "Pb-Free".

**RoHS Exempt:** TI defines "RoHS Exempt" to mean products that contain lead but are compliant with EU RoHS pursuant to a specific EU RoHS exemption.

**Green:** TI defines "Green" to mean the content of Chlorine (Cl) and Bromine (Br) based flame retardants meet JS709B low halogen requirements of <=1000ppm threshold. Antimony trioxide based flame retardants must also meet the <=1000ppm threshold requirement.

(3) MSL, Peak Temp. - The Moisture Sensitivity Level rating according to the JEDEC industry standard classifications, and peak solder temperature.

(4) There may be additional marking, which relates to the logo, the lot trace code information, or the environmental category on the device.

(5) Multiple Device Markings will be inside parentheses. Only one Device Marking contained in parentheses and separated by a "~" will appear on a device. If a line is indented then it is a continuation of the previous line and the two combined represent the entire Device Marking for that device.

(6) Lead finish/Ball material - Orderable Devices may have multiple material finish options. Finish options are separated by a vertical ruled line. Lead finish/Ball material values may wrap to two lines if the finish value exceeds the maximum column width.

**Important Information and Disclaimer:**The information provided on this page represents TI's knowledge and belief as of the date that it is provided. TI bases its knowledge and belief on information provided by third parties, and makes no representation or warranty as to the accuracy of such information. Efforts are underway to better integrate information from third parties. TI has taken and continues to take reasonable steps to provide representative and accurate information but may not have conducted destructive testing or chemical analysis on incoming materials and chemicals. TI and TI suppliers consider certain information to be proprietary, and thus CAS numbers and other limited information may not be available for release.



In no event shall TI's liability arising out of such information exceed the total purchase price of the TI part(s) at issue in this document sold by TI to Customer on an annual basis.

**OTHER QUALIFIED VERSIONS OF SN74LVC1G66-Q1 :**

- Catalog : [SN74LVC1G66](#)

NOTE: Qualified Version Definitions:

- Catalog - TI's standard catalog product

## TAPE AND REEL INFORMATION

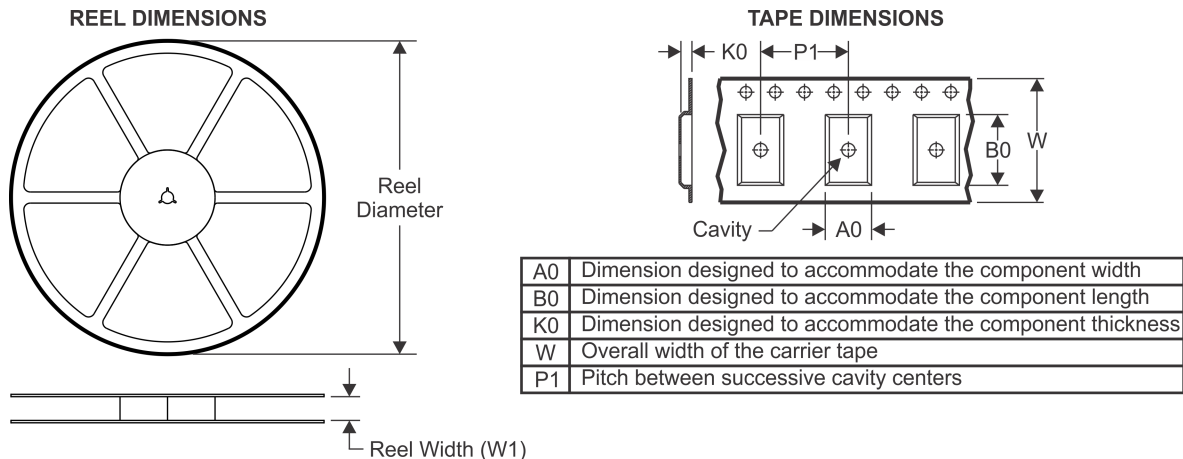

### QUADRANT ASSIGNMENTS FOR PIN 1 ORIENTATION IN TAPE



\*All dimensions are nominal

Device	Package Type	Package Drawing	Pins	SPQ	Reel Diameter (mm)	Reel Width W1 (mm)	A0 (mm)	B0 (mm)	K0 (mm)	P1 (mm)	W (mm)	Pin1 Quadrant
1P1G66QDBVRG4Q1	SOT-23	DBV	5	3000	180.0	8.4	3.23	3.17	1.37	4.0	8.0	Q3
1P1G66QDBVRQ1	SOT-23	DBV	5	3000	180.0	8.4	3.23	3.17	1.37	4.0	8.0	Q3
SN74LVC1G66QDCKRQ1	SC70	DCK	5	3000	179.0	8.4	2.2	2.5	1.2	4.0	8.0	Q3

**TAPE AND REEL BOX DIMENSIONS**

\*All dimensions are nominal

Device	Package Type	Package Drawing	Pins	SPQ	Length (mm)	Width (mm)	Height (mm)
1P1G66QDBVRG4Q1	SOT-23	DBV	5	3000	202.0	201.0	28.0
1P1G66QDBVRQ1	SOT-23	DBV	5	3000	202.0	201.0	28.0
SN74LVC1G66QDCKRQ1	SC70	DCK	5	3000	200.0	183.0	25.0

# DCK0005A



## PACKAGE OUTLINE

SOT - 1.1 max height

SMALL OUTLINE TRANSISTOR

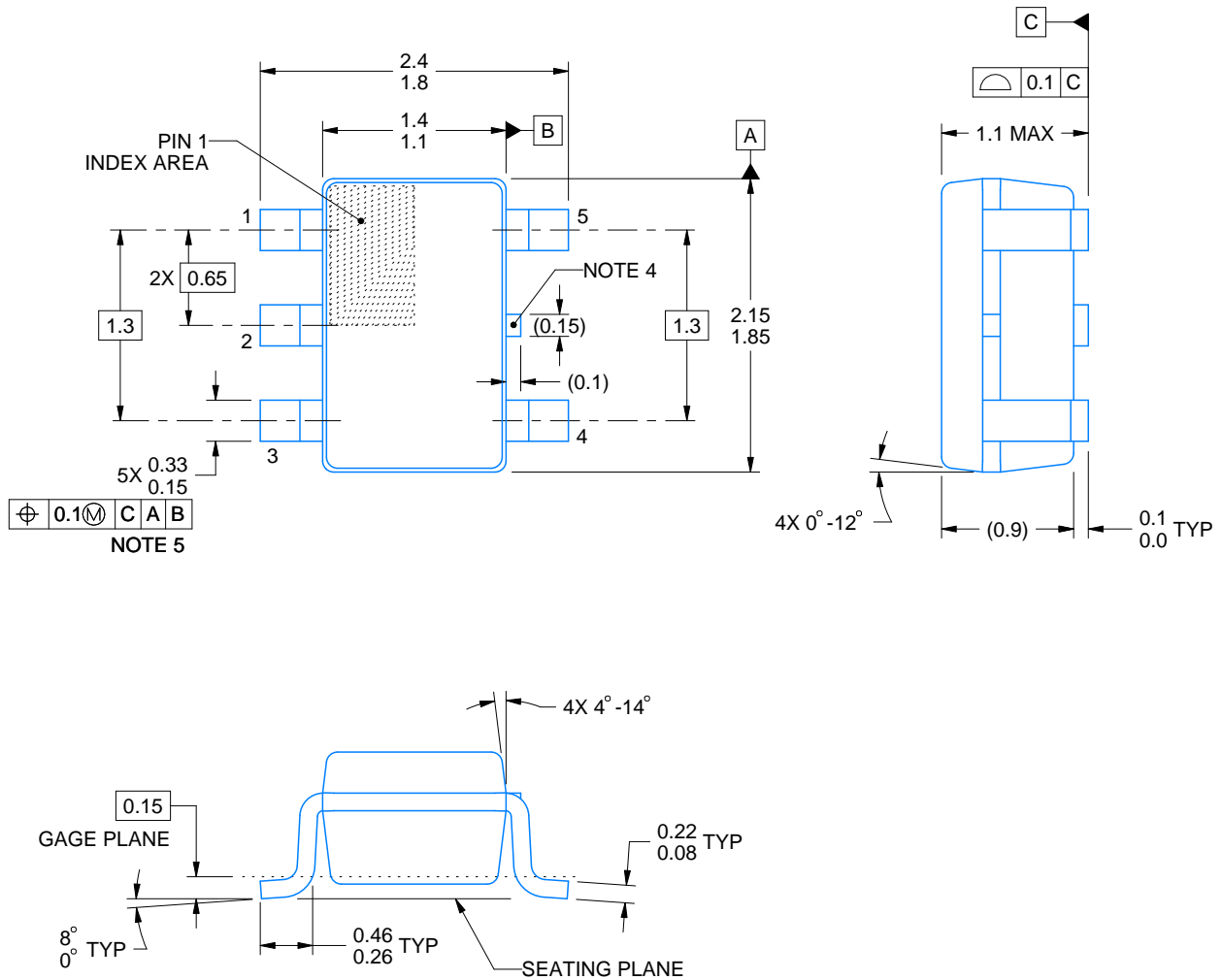

4214834/F 08/2024

### NOTES:

1. All linear dimensions are in millimeters. Any dimensions in parenthesis are for reference only. Dimensioning and tolerancing per ASME Y14.5M.
2. This drawing is subject to change without notice.
3. Reference JEDEC MO-203.
4. Support pin may differ or may not be present.
5. Lead width does not comply with JEDEC.
6. Body dimensions do not include mold flash, protrusions, or gate burrs. Mold flash, protrusions, or gate burrs shall not exceed 0.25mm per side

# EXAMPLE BOARD LAYOUT

DCK0005A

SOT - 1.1 max height

SMALL OUTLINE TRANSISTOR



LAND PATTERN EXAMPLE  
EXPOSED METAL SHOWN  
SCALE:18X



SOLDER MASK DETAILS

4214834/F 08/2024

NOTES: (continued)

- 7. Publication IPC-7351 may have alternate designs.
- 8. Solder mask tolerances between and around signal pads can vary based on board fabrication site.

# EXAMPLE STENCIL DESIGN

DCK0005A

SOT - 1.1 max height

SMALL OUTLINE TRANSISTOR

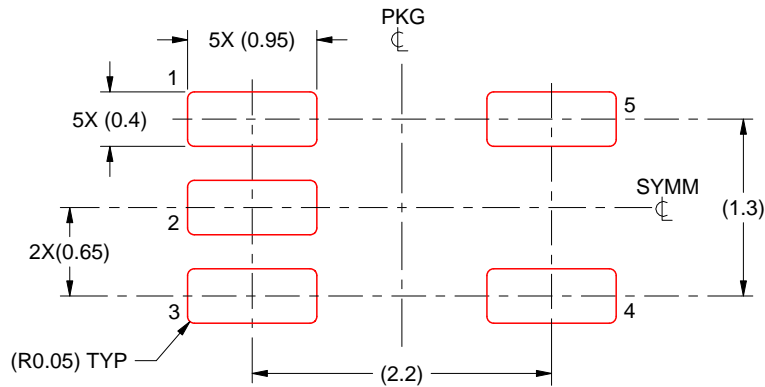

SOLDER PASTE EXAMPLE  
BASED ON 0.125 THICK STENCIL  
SCALE:18X

4214834/F 08/2024

NOTES: (continued)

9. Laser cutting apertures with trapezoidal walls and rounded corners may offer better paste release. IPC-7525 may have alternate design recommendations.
10. Board assembly site may have different recommendations for stencil design.

# DBV0005A



# PACKAGE OUTLINE

SOT-23 - 1.45 mm max height

SMALL OUTLINE TRANSISTOR

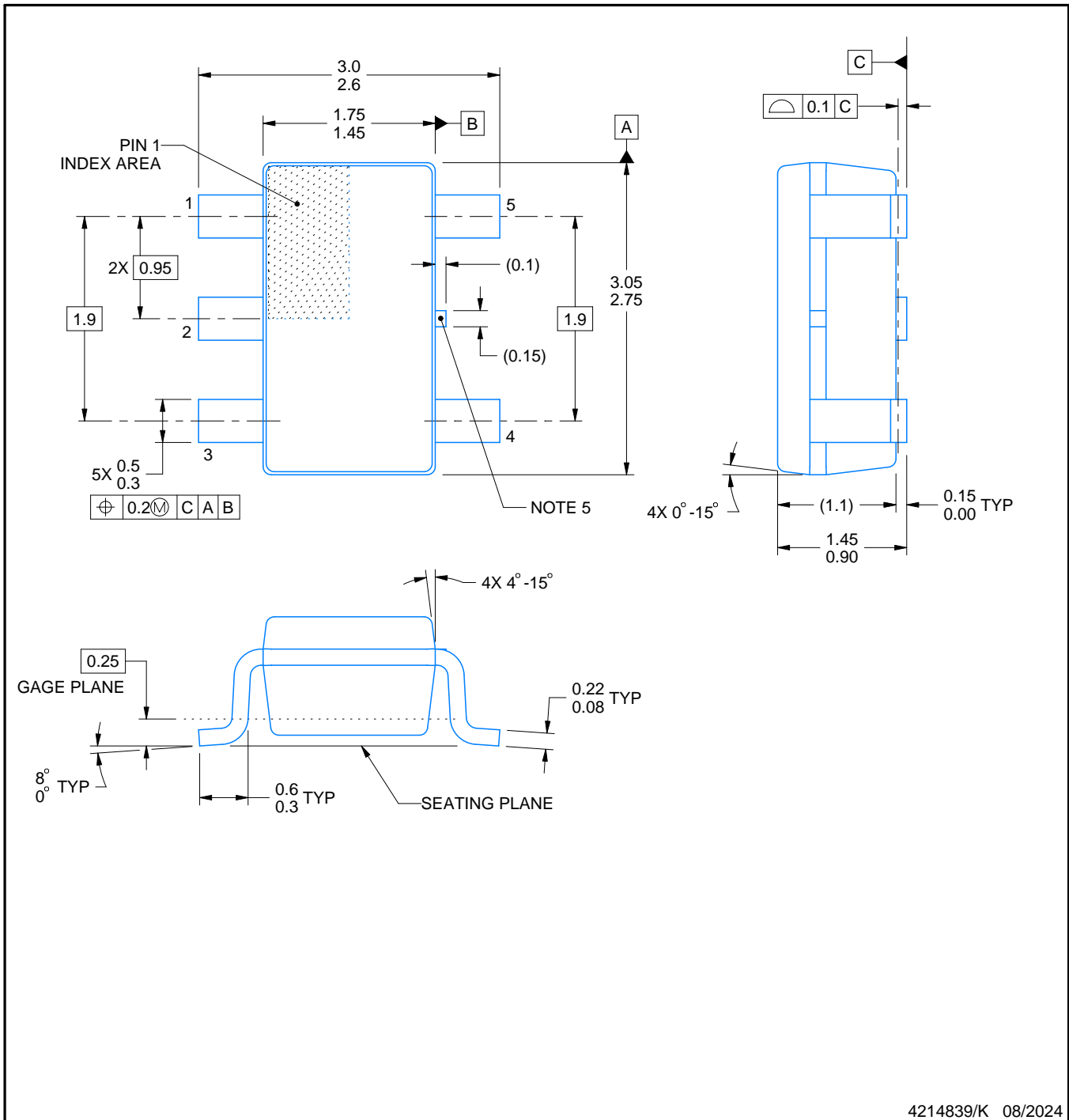

## NOTES:

1. All linear dimensions are in millimeters. Any dimensions in parenthesis are for reference only. Dimensioning and tolerancing per ASME Y14.5M.
2. This drawing is subject to change without notice.
3. Reference JEDEC MO-178.
4. Body dimensions do not include mold flash, protrusions, or gate burrs. Mold flash, protrusions, or gate burrs shall not exceed 0.25 mm per side.
5. Support pin may differ or may not be present.

# EXAMPLE BOARD LAYOUT

DBV0005A

SOT-23 - 1.45 mm max height

SMALL OUTLINE TRANSISTOR



LAND PATTERN EXAMPLE  
EXPOSED METAL SHOWN  
SCALE:15X



SOLDER MASK DETAILS

4214839/K 08/2024

NOTES: (continued)

- 6. Publication IPC-7351 may have alternate designs.
- 7. Solder mask tolerances between and around signal pads can vary based on board fabrication site.



# EXAMPLE STENCIL DESIGN

DBV0005A

SOT-23 - 1.45 mm max height

SMALL OUTLINE TRANSISTOR



SOLDER PASTE EXAMPLE  
BASED ON 0.125 mm THICK STENCIL  
SCALE:15X

4214839/K 08/2024

NOTES: (continued)

8. Laser cutting apertures with trapezoidal walls and rounded corners may offer better paste release. IPC-7525 may have alternate design recommendations.
9. Board assembly site may have different recommendations for stencil design.

## IMPORTANT NOTICE AND DISCLAIMER

TI PROVIDES TECHNICAL AND RELIABILITY DATA (INCLUDING DATA SHEETS), DESIGN RESOURCES (INCLUDING REFERENCE DESIGNS), APPLICATION OR OTHER DESIGN ADVICE, WEB TOOLS, SAFETY INFORMATION, AND OTHER RESOURCES "AS IS" AND WITH ALL FAULTS, AND DISCLAIMS ALL WARRANTIES, EXPRESS AND IMPLIED, INCLUDING WITHOUT LIMITATION ANY IMPLIED WARRANTIES OF MERCHANTABILITY, FITNESS FOR A PARTICULAR PURPOSE OR NON-INFRINGEMENT OF THIRD PARTY INTELLECTUAL PROPERTY RIGHTS.

These resources are intended for skilled developers designing with TI products. You are solely responsible for (1) selecting the appropriate TI products for your application, (2) designing, validating and testing your application, and (3) ensuring your application meets applicable standards, and any other safety, security, regulatory or other requirements.

These resources are subject to change without notice. TI grants you permission to use these resources only for development of an application that uses the TI products described in the resource. Other reproduction and display of these resources is prohibited. No license is granted to any other TI intellectual property right or to any third party intellectual property right. TI disclaims responsibility for, and you will fully indemnify TI and its representatives against, any claims, damages, costs, losses, and liabilities arising out of your use of these resources.

TI's products are provided subject to [TI's Terms of Sale](#) or other applicable terms available either on [ti.com](https://www.ti.com) or provided in conjunction with such TI products. TI's provision of these resources does not expand or otherwise alter TI's applicable warranties or warranty disclaimers for TI products.

TI objects to and rejects any additional or different terms you may have proposed.

Mailing Address: Texas Instruments, Post Office Box 655303, Dallas, Texas 75265  
Copyright © 2024, Texas Instruments Incorporated