

# TLIN1028S-Q1 車載用 70mA システム・ベース・チップ (SBC)

## 1 特長

- AEC-Q100 (グレード 1): 車載アプリケーション認定済み
- ローカル相互接続ネットワーク (LIN) 物理層仕様 ISO/DIS 17987-4 と LIN 用 SAEJ2602 推奨プラクティスに準拠 ([SLLA495](#) を参照)
- 機能安全対応
  - 機能安全システムの設計に役立つ資料を利用可能
- 12V アプリケーションをサポート
- 広い動作範囲
  - LIN バスのフォルト保護:  $\pm 58V$
  - 3.3V または 5V 対応の LDO 出力
  - スリープ・モード: 消費電流が非常に小さいため、以下からのウェイクアップ・イベントが可能:
    - LIN バスまたは EN ピン経由のローカル・ウェイクアップ
  - 電源オン/オフ時にグリッチが発生しない
- 保護機能:
  - ESD 保護、 $V_{SUP}$  低電圧保護
  - TXD ドミナント・タイムアウト (DTO) 保護、サーマル・シャットダウン
  - 電源なしノードまたはグラウンド切断に対するシステム・レベルのフェイルセーフ
- 最大 70mA の  $V_{CC}$  ソース
- SOIC (8) パッケージで供給

## 2 アプリケーション

- ボディ・エレクトロニクスおよび照明
- ハイブリッド、電気、パワートレイン・システム
- 車載用インフォテインメントおよびクラスタ
- 家電製品

## 3 概要

TLIN1028S-Q1 は、LIN 2.2AISO/DIS 17987-4 規格に準拠し、低ドロップアウト (LDO) 電圧レギュレータとを内蔵したローカル相互接続ネットワーク (LIN) 物理層トランシーバです。

LIN は単線式の双方向バスであり、データ・レートが最大 20kbps の低速車載ネットワークで一般に使用されています。本 LIN レシーバは、エンドオブライン・プログラミング用に最大 100kbps のデータ・レートをサポートしています。TLIN1028S-Q1 は、TXD 入力の LIN プロトコルのデータ・ストリームを、LIN バス信号に変換します。本レシーバは、データ・ストリームを論理レベル信号に変換し、オープン・ドレインの RXD ピンを経由してマイクロプロセッサに送信します。TLIN1028S-Q1 は、マイクロプロセッサ、センサ、その他のデバイスに最大 70mA の電流供給能力を持つ 3.3V または 5V レールを提供することで、システムの複雑さを軽減します。TLIN1028S-Q1 には、電磁気放射 (EME) を減少させる最適化された電流制限機能付き波形成形ドライバが搭載されています。

### 製品情報

部品番号	パッケージ <sup>(1)</sup>	本体サイズ (公称)
TLIN1028S-Q1	SOIC (8)	4.90mm × 3.91mm

(1) 利用可能なすべてのパッケージについては、このデータシートの末尾にある注文情報を参照してください。

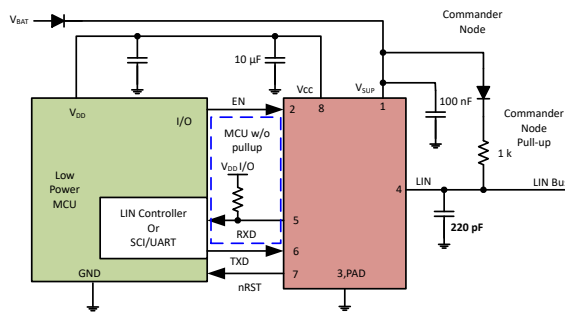

概略回路図、コマンド・ノード(1)

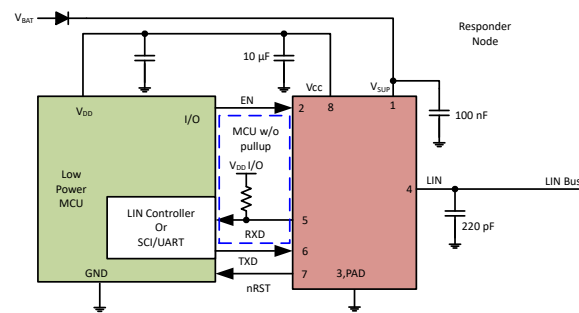

概略回路図、レスポнда・ノード(2)



## Table of Contents

1 特長.....	1	9.2 Functional Block Diagram.....	20
2 アプリケーション.....	1	9.3 Feature Description.....	20
3 概要.....	1	9.4 Device Functional Modes.....	24
4 Revision History.....	2	<b>10 Application and Implementation.....</b>	<b>28</b>
5 概要 (続き).....	3	10.1 Application Information.....	28
6 Pin Configuration and Functions.....	4	10.2 Typical Application.....	28
7 Specification.....	5	<b>11 Power Supply Recommendations.....</b>	<b>31</b>
7.1 ABSOLUTE MAXIMUM RATINGS.....	5	<b>12 Layout.....</b>	<b>32</b>
7.2 ESD RATINGS.....	5	12.1 Layout Guidelines.....	32
7.3 ESD RATINGS, IEC SPECIFICATION.....	5	12.2 Layout Example.....	33
7.4 RECOMMENDED OPERATING CONDITIONS.....	5	<b>13 Device and Documentation Support.....</b>	<b>34</b>
7.5 THERMAL INFORMATION.....	6	13.1 Documentation Support.....	34
7.6 POWER SUPPLY CHARACTERISTICS.....	6	13.2 Receiving Notification of Documentation Updates..	34
7.7 ELECTRICAL CHARACTERISTICS.....	7	13.3 サポート・リソース.....	34
7.8 AC SWITCHING CHARACTERISTICS.....	9	13.4 Trademarks.....	34
7.9 Typical Characteristics.....	10	13.5 Electrostatic Discharge Caution.....	35
8 Parameter Measurement Information.....	11	13.6 Glossary.....	35
8.1 Test Circuit: Diagrams and Waveforms.....	11	<b>14 Mechanical, Packaging, and Orderable Information.....</b>	<b>35</b>
9 Detailed Description.....	20		
9.1 Overview.....	20		

## 4 Revision History

資料番号末尾の英字は改訂を表しています。その改訂履歴は英語版に準じています。

Changes from Revision A (May 2020) to Revision B (February 2022)	Page
• 旧式の用語を使っている場合、すべてコマンドおよびレスポンスに変更。.....	1
• Changed <i>nRST is only dependent.</i> statement to: <i>nRST is dependent</i> in the <b>nRST (Reset Output)</b> section...	22

Changes from Revision * (November 2019) to Revision A (May 2020)	Page
• 「特長」のリストに「SLLA495 を参照」を追加.....	1
• 「特長」に「機能安全対応」を追加.....	1
• Added : See errata TLIN1028S-Q1 Duty Cycle Over $V_{SUP}$ .....	7

## 5 概要 (続き)

スリープ・モードから LIN バスやピンによるウェイクアップが可能のため、非常に低い消費電流を実現できます。LIN バスには、ドミナント状態 (グラウンドに近い電圧) とリセッシブ状態 (バッテリーに近い電圧) という 2 つの状態があります。リセッシブ状態では、内蔵プルアップ抵抗 (45k $\Omega$ ) および直列ダイオードにより、LIN バスが HIGH になります。レスポнда用途では、外付けプルアップ部品は不要です。コントローラ用途では、LIN 仕様に従って外付けプルアップ抵抗 (1k $\Omega$ ) と直列ダイオードが必要です。

## 6 Pin Configuration and Functions



图 6-1. D Package, 8-Pin (SOIC), Top View

表 6-1. Pin Functions

PIN		TYPE <sup>(1)</sup>	DESCRIPTION
NO.	NAME		
1	V <sub>SUP</sub>	HV Supply In	Device supply voltage (connected to battery in series with external reverse-blocking diode)
2	EN	D I	Enable input
3	GND	GND	Ground <sup>(2)</sup>
4	LIN	HV I/O	LIN bus single-wire transmitter and receiver
5	RXD	D O	RXD output (open-drain) interface reporting state of LIN bus voltage
6	TXD	D I	TXD input interface to control state of LIN output
7	nRST	D O	Reset output (active low)
8	V <sub>CC</sub>	Supply Out	Output voltage from integrated LDO

- (1) HV - High Voltage, DI - Digital Input, DO - Digital Output, HV I/O - High Voltage Input/Output  
 (2) When the thermal pad is present, it must be soldered to ground plane.

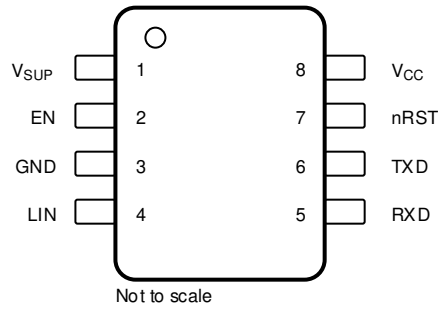
## 7 Specification

### 7.1 ABSOLUTE MAXIMUM RATINGS

(1)

		MIN	MAX	UNIT
V <sub>SUP</sub>	Supply voltage range	-0.3	42	V
V <sub>LIN</sub>	LIN Bus input voltage	-58	58	V
V <sub>CC50</sub>	Regulated 5 V Output Supply	-0.3	6	V
V <sub>CC33</sub>	Regulated 3.3 V Output Supply	-0.3	4.5	V
V <sub>nRST</sub>	Reset output voltage	-0.3	V <sub>CC</sub> + 0.3	V
V <sub>LOGIC_INPUT</sub>	Logic input voltage	-0.3	6	V
V <sub>LOGIC_OUTPUT</sub>	Logic output voltage	-0.3	6	V
I <sub>VCC</sub>	V <sub>CC</sub> supply current <sup>(2)</sup>		300	mA
I <sub>O</sub>	Digital pin output current	-8	8	mA
I <sub>O(nRST)</sub>	Reset output current	-5	5	mA
T <sub>J</sub>	Junction temperature	-40	165	°C
T <sub>stg</sub>	Storage temperature range	-65	150	°C

- (1) Stresses beyond those listed under *Absolute Maximum Ratings* may cause permanent damage to the device. These are stress ratings only, which do not imply functional operation of the device at these or any other conditions beyond those indicated under *Recommended Operating Conditions*. Exposure to absolute-maximum-rated conditions for extended periods may affect device reliability.
- (2) Device will enter thermal shutdown prior to hitting this limit but if the limit is reached the device may sustain permanent damage.

### 7.2 ESD RATINGS

			VALUE	UNIT
V <sub>(ESD)</sub>	Electrostatic discharge	Human body model (HBM) classification level H2: V <sub>SUP</sub> , LIN, and WAKE with respect to ground	±8000	V
		Human body model (HBM) classification level 3A: all other pins, per AEC Q100-002 <sup>(1)</sup>	±4000	
		Charged device model (CDM) classification level C5, per AEC Q100-011	All pins	

- (1) AEC Q100-002 indicates that HBM stressing shall be in accordance with the ANSI/ESDA/JEDEC JS-001 specification.

### 7.3 ESD RATINGS, IEC SPECIFICATION

			VALUE	UNIT
V <sub>(ESD)</sub>	Electrostatic discharge per IEC 62228-2 <sup>(1)</sup> , LIN, V <sub>SUP</sub> terminal to GND	Contact discharge	±15000	V
		Indirect	±15000	V
V <sub>(ESD)</sub>	Powered electrostatic discharge per SAE J2962-1 <sup>(2)</sup>	Contact discharge	±8000	V
		Air discharge	±25000	
Transient	ISO 7637-2 and IEC 62215-3 transients per IEC 62228-2 <sup>(1)</sup>	Pulse 1	-100	V
		Pulse 2a	75	
		Pulse 3a	-150	
		Pulse 3b	100	

- (1) IEC 62228-2 ESD testing performed at third party. Different system-level configurations may lead to different results. Test reports available upon request.
- (2) SAE J2962-1 Testing performed at 3rd party US3 approved EMC test facility, test report available upon request.

### 7.4 RECOMMENDED OPERATING CONDITIONS

		MIN	NOM	MAX	UNIT
V <sub>SUP</sub>	Supply voltage	5.5		28	V

## 7.4 RECOMMENDED OPERATING CONDITIONS (continued)

		MIN	NOM	MAX	UNIT
V <sub>LIN</sub>	LIN bus input voltage	0		28	V
V <sub>LOGIC5</sub>	Logic pin voltage	0		5.25	V
V <sub>LOGIC33</sub>	Logic pin voltage	0		3.465	V
I <sub>OH(DO)</sub>	Digital terminal HIGH level output current	-2			mA
I <sub>OL(DO)</sub>	Digital terminal LOW level output current			2	mA
C <sub>(VSUP)</sub>	V <sub>SUP</sub> supply capacitor	100			nF
C <sub>(VCC)</sub>	V <sub>CC</sub> supply capacitor	10			μF
ESR <sub>CO</sub>	Output ESR requirements	0.001		2	Ω

## 7.5 THERMAL INFORMATION

THERMAL METRIC <sup>(1)</sup>		TLIN1028x	UNIT
		D	
		8 PINS	
R <sub>θJA</sub>	Junction-to-ambient thermal resistance	119.4	°C/W
R <sub>θJC(top)</sub>	Junction-to-case (top) thermal resistance	51.5	°C/W
R <sub>θJB</sub>	Junction-to-board thermal resistance	64.9	°C/W
ψ <sub>JT</sub>	Junction-to-top characterization parameter	9.6	°C/W
ψ <sub>JB</sub>	Junction-to-board characterization parameter	63.7	°C/W
R <sub>θJC(bot)</sub>	Junction-to-case (bottom) thermal resistance	n/a	°C/W

- (1) For more information about traditional and new thermal metrics, see the [Semiconductor and IC Package Thermal Metrics](#) application report.

## 7.6 POWER SUPPLY CHARACTERISTICS

parameters valid over  $-40^{\circ}\text{C} \leq T_J \leq 150^{\circ}\text{C}$  range (unless otherwise noted)

PARAMETER		TEST CONDITIONS	MIN	TYP	MAX	UNIT
<b>SUPPLY VOLTAGE AND CURRENT</b>						
V <sub>SUP</sub>	Operational supply voltage (ISO/DIS 17987 Param 10)	Device is operational beyond the LIN defined nominal supply voltage range. See <a href="#">8-1</a> and <a href="#">8-2</a>	5.5		36	V
V <sub>SUP</sub>	Nominal supply voltage (ISO/DIS 17987 Param 10):	Normal and Standby Modes: Ramp V <sub>SUP</sub> while LIN signal is a 10 kHz square wave with 50 % duty cycle and swing between 5.5 V ≤ V <sub>LIN</sub> ≤ 28 V. See <a href="#">8-1</a> and <a href="#">8-2</a>	5.5		28	V
		Sleep Mode	5.5		28	V
UV <sub>SUPR</sub>	Under voltage V <sub>SUP</sub> threshold	Ramp Up		3.5	4.2	V
UV <sub>SUPF</sub>	Under voltage V <sub>SUP</sub> threshold	Ramp Down	1.8	2.1	2.5	V
U <sub>VHYS</sub>	Delta hysteresis voltage for V <sub>SUP</sub> under voltage threshold			1.5		V
I <sub>SUP</sub>	Transceiver and LDO supply current	Transceiver normal mode dominant plus LDO output			80	mA
I <sub>SUPTRXDOM</sub>	Supply current transceiver only	Normal Mode: EN = V <sub>CC</sub> , bus dominant: total bus load where R <sub>LIN</sub> ≥ 500 Ω and C <sub>LIN</sub> ≤ 10 nF		1.2	5	mA
		Standby Mode: EN = 0 V, bus dominant: total bus load where R <sub>LIN</sub> ≥ 500 Ω and C <sub>LIN</sub> ≤ 10 nF		1	1.8	mA

## 7.6 POWER SUPPLY CHARACTERISTICS (continued)

parameters valid over  $-40^{\circ}\text{C} \leq T_J \leq 150^{\circ}\text{C}$  range (unless otherwise noted)

PARAMETER		TEST CONDITIONS	MIN	TYP	MAX	UNIT
$I_{\text{SUPTRXREC}}$	Supply current transceiver only	Normal Mode: $\text{EN} = V_{\text{CC}}$ , Bus recessive: $\text{LIN} = V_{\text{SUP}}$ ,		450	775	$\mu\text{A}$
		Standby Mode: $\text{EN} = 0\text{ V}$ , $\text{LIN} = \text{recessive} = V_{\text{SUP}}$ , $I_{\text{OZH}}$ from processor $\leq 1\ \mu\text{A}$		38	55	$\mu\text{A}$
		Added Standby Mode current through the RXD pull-up resistor with a value of 100 k $\Omega$ : $\text{EN} = 0\text{ V}$ , $\text{LIN} = \text{recessive} = V_{\text{SUP}}$ , $\text{RXD} = \text{GND}^{(1)}$			55	
$I_{\text{SUPTRXSLEP}}$	Sleep mode supply current transceiver only	$5.5\text{ V} < V_{\text{SUP}} \leq 28\text{ V}$ , $\text{LIN} = V_{\text{SUP}}$ , $\text{EN} = 0\text{ V}$ , TXD and RXD floating		17	33	$\mu\text{A}$
<b>REGULATED OUTPUT <math>V_{\text{CC}}</math></b>						
$V_{\text{CC}}$	Regulated output	$V_{\text{SUP}} = 5.5$ to $28\text{ V}$ , $I_{\text{CC}} = 1$ to $70\text{ mA}$	-2		2	%
$\Delta V_{\text{CC}(\Delta V_{\text{SUP}})}$	Line regulation	$V_{\text{SUP}} = 5.5$ to $28\text{ V}$ , $\Delta V_{\text{CC}}$ , $I_{\text{CC}} = 10\text{ mA}$			50	mV
$\Delta V_{\text{CC}(\Delta V_{\text{SUPL}})}$	Load regulation	$I_{\text{CC}} = 1$ to $70\text{ mA}$ , $V_{\text{SUP}} = 14\text{ V}$ , $\Delta V_{\text{CC}}$			50	mV
$V_{\text{DROP}}$	Dropout voltage (5 V LDO)	$V_{\text{SUP}} - V_{\text{CC}}$ , $I_{\text{CC}} = 70\text{ mA}$ ;		300	600	mV
$V_{\text{DROP}}$	Dropout voltage (3.3 V LDO)	$V_{\text{SUP}} - V_{\text{CC}}$ , $I_{\text{CC}} = 70\text{ mA}$ ;		350	700	mV
$UV_{\text{CC5R}}$	Under voltage 5 V $V_{\text{CC}}$ threshold	Ramp Up		4.7	4.86	V
$UV_{\text{CC5F}}$	Under voltage 5 V $V_{\text{CC}}$ threshold	Ramp Down	4.2	4.45		V
$UV_{\text{CC33R}}$	Under voltage 3.3 V $V_{\text{CC}}$ threshold <sup>(2)</sup>	Ramp Up		2.9	3.1	V
$UV_{\text{CC33F}}$	Under voltage 3.3 V $V_{\text{CC}}$ threshold <sup>(2)</sup>	Ramp Down	2.5	2.75		V
$t_{\text{DET}(UV_{\text{CC}})}$	VCC undervoltage deglitch time. An $UV_{\text{CC}}$ event will not be recognized unless it last longer than this. <sup>(2)</sup>	$C_{\text{nRST}} = 20\text{ pF}$	1		15	$\mu\text{s}$
$I_{\text{CCOUT}}$	Output current	$V_{\text{CC}}$ in regulation with $12\text{ V } V_{\text{SUP}}$	0		70	mA
$I_{\text{CCOUTL}}$	Output current limit	$V_{\text{CC}}$ short to ground			275	mA
PSRR	Power supply rejection ripple rejection	$V_{\text{RIP}} = 0.5 V_{\text{PP}}$ , Load = $10\text{ mA}$ , $f = 100\text{ Hz}$ , $C_{\text{O}} = 10\ \mu\text{F}$		60		dB
$T_{\text{SDR}}$	Thermal shutdown temperature	Internal junction temperature - rising	165			$^{\circ}\text{C}$
$T_{\text{SDF}}$	Thermal shutdown temperature	Internal junction temperature - falling			150	$^{\circ}\text{C}$
$T_{\text{SDHYS}}$	Thermal shutdown hysteresis			10		$^{\circ}\text{C}$

- (1) RXD pin is an open drain output. In standby mode RXD is pulled low which has the device pulling current through  $V_{\text{SUP}}$  through the pull-up resistor to  $V_{\text{CC}}$ . The value of the pull-up resistor impacts the standby mode current. A 10 k $\Omega$  resistor value can add as much as 500  $\mu\text{A}$  of current.
- (2) Specified by design

## 7.7 ELECTRICAL CHARACTERISTICS

parameters valid over  $-40^{\circ}\text{C} \leq T_J \leq 150^{\circ}\text{C}$  range (unless otherwise noted)

PARAMETER		TEST CONDITIONS	MIN	TYP	MAX	UNIT
<b>RXD OUTPUT TERMINAL (OPEN DRAIN)</b>						
$V_{\text{OL}}$	Output low voltage	Based upon a 2 k $\Omega$ to 10 k $\Omega$ external pull-up to $V_{\text{CC}}$			0.2	$V_{\text{CC}}$
$I_{\text{OL}}$	Low level output current, open drain	$\text{LIN} = 0\text{ V}$ , $\text{RXD} = 0.4\text{ V}$	1.5			mA
$I_{\text{LKG}}$	Leakage current, high-level	$\text{LIN} = V_{\text{SUP}}$ , $\text{RXD} = V_{\text{CC}}$	-5	0	5	$\mu\text{A}$
<b>TXD INPUT TERMINAL</b>						
$V_{\text{IL}}$	Low level input voltage		-0.3		0.8	V
$V_{\text{IH}}$	High level input voltage		2		5.5	V
$I_{\text{IH}}$	High level input leakage current	TXD = high	-5	0	5	$\mu\text{A}$
$R_{\text{TXD}}$	Internal pull-up resistor value		125	350	800	k $\Omega$
<b>LIN TERMINAL (REFERENCED TO <math>V_{\text{SUP}}</math>)</b>						
$V_{\text{OH}}$	HIGH level output voltage	$\text{LIN} = \text{recessive}$ , TXD = high, $I_{\text{O}} = 0\text{ mA}$ , $V_{\text{SUP}} = 5.5\text{ V}$ to $36\text{ V}$	0.85			$V_{\text{SUP}}$

## 7.7 ELECTRICAL CHARACTERISTICS (continued)

 parameters valid over  $-40^{\circ}\text{C} \leq T_J \leq 150^{\circ}\text{C}$  range (unless otherwise noted)

PARAMETER		TEST CONDITIONS	MIN	TYP	MAX	UNIT
$V_{OL}$	LOW level output voltage	LIN dominant, TXD = low, $V_{SUP} = 5.5\text{ V}$ to $36\text{ V}$			0.2	$V_{SUP}$
$V_{SUP\_NON\_OP}$	$V_{SUP}$ where impact of recessive LIN bus < 5% (ISO/DIS 17987 Param 11)	TXD & RXD open, $V_{LIN} = 5.5\text{ V}$ to $42\text{ V}$ , Bus Load = $60\text{ k}\Omega$ + diode and $1.1\text{ k}\Omega$ + diode	-0.3		42	V
$I_{BUS\_LIM}$	Limiting current (ISO/DIS 17987 Param 12)	TXD = 0 V, $V_{LIN} = 36\text{ V}$ , $R_{MEAS} = 440\ \Omega$ , $V_{SUP} = 36\text{ V}$ , $V_{BUSdom} < 4.518\text{ V}$ ; <a href="#">8-5</a>	40	90	200	mA
$I_{BUS\_PAS\_dom}$	Receiver leakage current, dominant (ISO/DIS 17987 Param 13)	$V_{LIN} = 0\text{ V}$ , $V_{SUP} = 12\text{ V}$ Driver off/recessive, $R_{MEAS} = 499\ \Omega$ ; <a href="#">8-6</a>	-1			mA
$I_{BUS\_PAS\_rec1}$	Receiver leakage current, recessive (ISO/DIS 17987 Param 14)	$V_{LIN} \geq V_{SUP}$ , $5.5\text{ V} \leq V_{SUP} \leq 36\text{ V}$ Driver off, $R_{MEAS} = 1\text{ k}\Omega$ ; <a href="#">8-7</a>			20	$\mu\text{A}$
$I_{BUS\_PAS\_rec2}$	Receiver leakage current, recessive (ISO/DIS 17987 Param 14)	$V_{LIN} = V_{SUP}$ , Driver off, $R_{MEAS} = 1\text{ k}\Omega$ ; <a href="#">8-7</a>	-8		8	$\mu\text{A}$
$I_{BUS\_NO\_GND}$	Leakage current, loss of ground (ISO/DIS 17987 Param 15)	$GND = V_{SUP}$ , $V_{SUP} = 12\text{ V}$ , $0\text{ V} \leq V_{LIN} \leq 28\text{ V}$ , $R_{MEAS} = 1\text{ k}\Omega$ ; <a href="#">8-8</a>	-1		1	mA
$I_{BUS\_NO\_BAT}$	Leakage current, loss of supply (ISO/DIS 17987 Param 16)	$0\text{ V} \leq V_{LIN} \leq 28\text{ V}$ , $V_{SUP} = GND$ , $R_{MEAS} = 10\text{ k}\Omega$ ; <a href="#">8-9</a>			8	$\mu\text{A}$
$V_{BUSdom}$	Low level input voltage (ISO/DIS 17987 Param 17)	LIN dominant (including LIN dominant for wake up); <a href="#">8-3</a> , <a href="#">8-4</a>			0.4	$V_{SUP}$
$V_{BUSrec}$	High level input voltage (ISO/DIS 17987 Param 18)	LIN recessive; <a href="#">8-3</a> , <a href="#">8-4</a>	0.6			$V_{SUP}$
$V_{BUS\_CNT}$	Receiver center threshold (ISO/DIS 17987 Param 19)	$V_{BUS\_CNT} = (V_{IL} + V_{IH})/2$ ; <a href="#">8-3</a> , <a href="#">8-4</a>	0.475	0.5	0.525	$V_{SUP}$
$V_{HYS}$	Hysteresis voltage (ISO/DIS 17987 Param 20)	$V_{HYS} = (V_{IL} - V_{IH})$ ; <a href="#">8-3</a> , <a href="#">8-4</a>			0.175	$V_{SUP}$
$V_{SERIAL\_DIODE}$	Serial diode LIN term pull-up path (ISO/DIS 17987 Param 21)	By design and characterization	0.4	0.7	1.0	V
$R_{RESPONDER}$	Pull-up resistor to $V_{SUP}$ (ISO/DIS 17987 Param 26)	Normal and Standby modes	20	45	60	$\text{k}\Omega$
$I_{RSLEEP}$	Pull-up current source to $V_{SUP}$	Sleep mode, $V_{SUP} = 12\text{ V}$ , LIN = GND	-20		-2	$\mu\text{A}$
$C_{LIN,PIN}$	Capacitance of the LIN pin				55	pF
<b>EN INPUT TERMINAL</b>						
$V_{IH}$	High level input voltage		2		5.5	V
$V_{IL}$	Low level input voltage		-0.3		0.8	V
$V_{HYS}$	Hysteresis voltage	By design and characterization	30		500	mV
$I_{IL}$	Low level input current	EN = Low	-5	0	5	$\mu\text{A}$
$R_{EN}$	Internal pull-down resistor		125	350	800	$\text{k}\Omega$
$I_{LKG}$	Leakage current, high-level	LIN = $V_{SUP}$ , nRST = $V_{CC}$	-5		5	$\mu\text{A}$
$V_{OL}$	Low-level output voltage	Based upon external pull up to $V_{CC}$			0.2	$V_{CC}$
$I_{OL}$	Low-level output current, open drain	LIN = 0 V, nRST = 0.4 V	1.5			mA
<b>DUTY CYCLE CHARACTERISTICS<sup>(1)</sup></b>						
$D1_{12V}$	Duty Cycle 1 (ISO/DIS 17987 Param 27)	$TH_{REC(MAX)} = 0.744 \times V_{SUP}$ , $TH_{DOM(MAX)} = 0.581 \times V_{SUP}$ , $V_{SUP} = 5.5\text{ V}$ to $18\text{ V}$ , $t_{BIT} = 50\ \mu\text{s}$ (20 kbps), $D1 = t_{BUS\_rec(min)}/(2 \times t_{BIT})$ (See <a href="#">8-10</a> , <a href="#">8-11</a> )	0.396			
$D2_{12V}$	Duty Cycle 2 (ISO/DIS 17987 Param 28)	$TH_{REC(MIN)} = 0.422 \times V_{SUP}$ , $TH_{DOM(MIN)} = 0.284 \times V_{SUP}$ , $V_{SUP} = 5.5\text{ V}$ to $18\text{ V}$ , $t_{BIT} = 50\ \mu\text{s}$ (20 kbps), $D2 = t_{BUS\_rec(MAX)}/(2 \times t_{BIT})$ (See <a href="#">8-10</a> , <a href="#">8-11</a> )			0.581	
$D3_{12V}$	Duty Cycle 3 (ISO/DIS 17987 Param 29)	$TH_{REC(MAX)} = 0.778 \times V_{SUP}$ , $TH_{DOM(MAX)} = 0.616 \times V_{SUP}$ , $V_{SUP} = 5.5\text{ V}$ to $18\text{ V}$ , $t_{BIT} = 96\ \mu\text{s}$ (10.4 kbps), $D3 = t_{BUS\_rec(min)}/(2 \times t_{BIT})$ (See <a href="#">8-10</a> , <a href="#">8-11</a> )	0.417			



## 7.7 ELECTRICAL CHARACTERISTICS (continued)

parameters valid over  $-40^{\circ}\text{C} \leq T_J \leq 150^{\circ}\text{C}$  range (unless otherwise noted)

PARAMETER		TEST CONDITIONS	MIN	TYP	MAX	UNIT
D4 <sub>12V</sub>	Duty Cycle 4 (ISO/DIS 17987 Param 30)	$T_{HREC(MIN)} = 0.389 \times V_{SUP}$ , $T_{HDOM(MIN)} = 0.251 \times V_{SUP}$ , $V_{SUP} = 5.5\text{ V to }18\text{ V}$ , $t_{BIT} = 96\ \mu\text{s}$ (10.4 kbps), $D4 = t_{BUS\_rec(MAX)}/(2 \times t_{BIT})$ (See <a href="#">8-10</a> , <a href="#">8-11</a> )			0.59	

(1) See errata [TLIN1028S-Q1 Duty Cycle Over V<sub>SUP</sub>](#)

## 7.8 AC SWITCHING CHARACTERISTICS

parameters valid over  $-40^{\circ}\text{C} \leq T_J \leq 150^{\circ}\text{C}$  range (unless otherwise noted)

PARAMETER		TEST CONDITIONS	MIN	TYP	MAX	UNIT
<b>DEVICE SWITCHING CHARACTERISTICS</b>						
$t_{rx\_pdr}$ $t_{rx\_pdf}$	Receiver rising/falling propagation delay time (ISO/DIS 17987 Param 31)	$R_{RXD} = 2.4\ \text{k}\Omega$ , $C_{RXD} = 20\ \text{pF}$ (See <a href="#">8-12</a> , <a href="#">8-13</a> and <a href="#">8-17</a> )			6	$\mu\text{s}$
$t_{rx\_sym}$	Symmetry of receiver propagation delay time Receiver rising propagation delay time (ISO/DIS 17987 Param 32)	Rising edge with respect to falling edge, ( $t_{rx\_sym} = t_{rx\_pdf} - t_{rx\_pdr}$ ), $R_{RXD} = 2.4\ \text{k}\Omega$ , $C_{RXD} = 20\ \text{pF}$ ( <a href="#">8-12</a> , <a href="#">8-13</a> and <a href="#">8-17</a> )	-2		2	$\mu\text{s}$
$t_{LINBUS}$	LIN wakeup time (minimum dominant time on LIN bus for wakeup)	See <a href="#">8-16</a> , <a href="#">9-3</a> and <a href="#">9-4</a>	25	100	150	$\mu\text{s}$
$t_{CLEAR}$	Time to clear false wakeup prevention logic if LIN bus had a bus stuck dominant fault (recessive time on LIN bus to clear bus stuck dominant fault)	See <a href="#">9-4</a>	8	17	50	$\mu\text{s}$
$t_{TXD\_DTO}$	Dominant state time out		20	34	80	ms
$t_{EN}$	Enable pin deglitch time	Time enable pin state change before initiating mode change or sampling TXD pine: See <a href="#">8-14</a>	3		12	$\mu\text{s}$
$t_{MODE\_CHANGE}$	Mode change delay time normal mode to sleep or standby mode	Time to change from normal mode to sleep or standby after TXD pin sampling after EN pin set low: See <a href="#">8-14</a>			20	$\mu\text{s}$
$t_{MODE\_CHANGE}$	Mode change delay time sleep mode to normal mode	Time to change from sleep mode to normal mode through EN pin and not due to a wake event; RXD pulled up to $V_{CC}$ : See <a href="#">8-14</a>			400	$\mu\text{s}$
$t_{NOMINT}$	Normal mode initialization time	Time for normal mode to initialize and data on RXD pin to be valid after $t_{EN}$ See <a href="#">8-14</a>			35	$\mu\text{s}$
$t_{PWR}$	Power up time	Upon power up time it takes for valid data on RXD			1.5	ms

## 7.9 Typical Characteristics

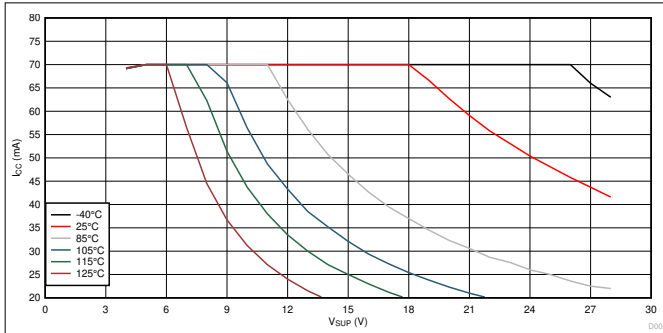

**7-1.  $I_{CC}$  vs  $V_{SUP}$  vs Temperature**

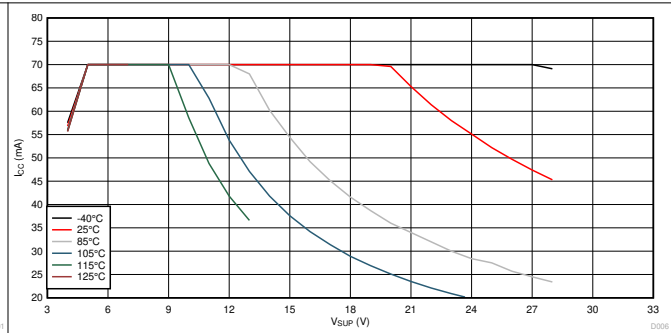

**7-2.  $I_{CC}$  vs  $V_{SUP}$  vs Temperature**

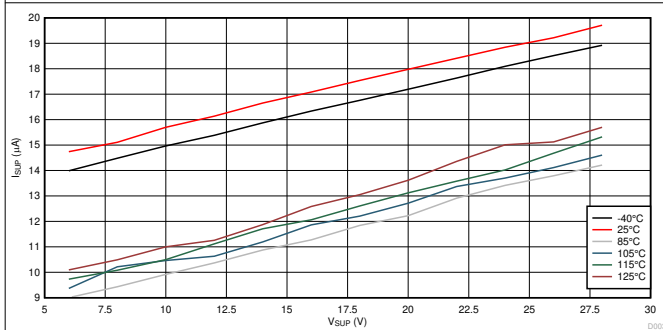

**7-3. Sleep Mode Current Across  $V_{SUP}$  and Temperature**

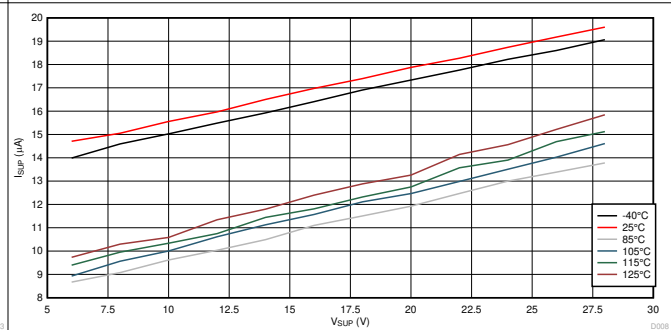

**7-4. Sleep Mode Current Across  $V_{SUP}$  and Temperature**

## 8 Parameter Measurement Information

### 8.1 Test Circuit: Diagrams and Waveforms

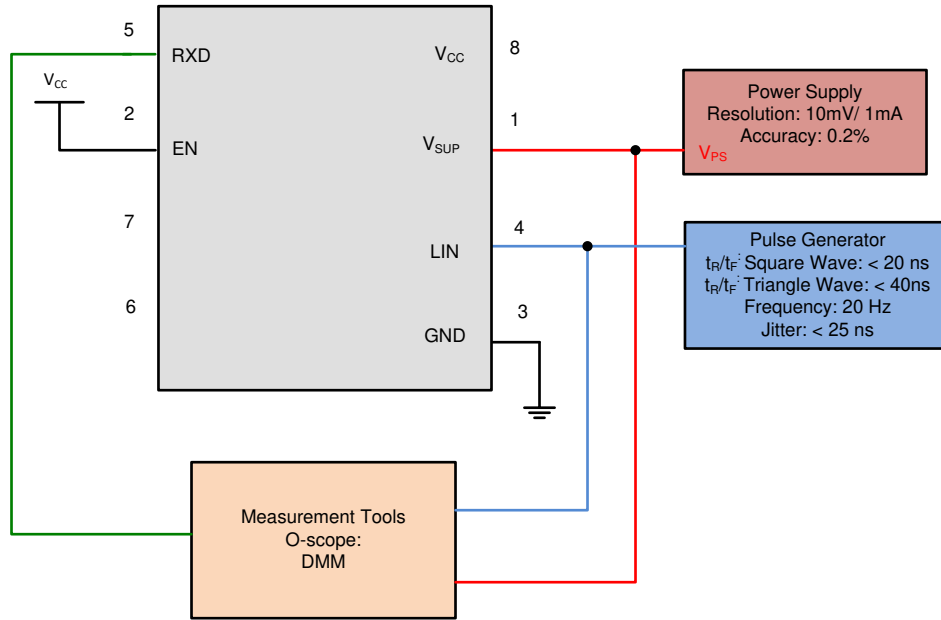

**8-1. Test System: Operating Voltage Range with RX and TX Access**

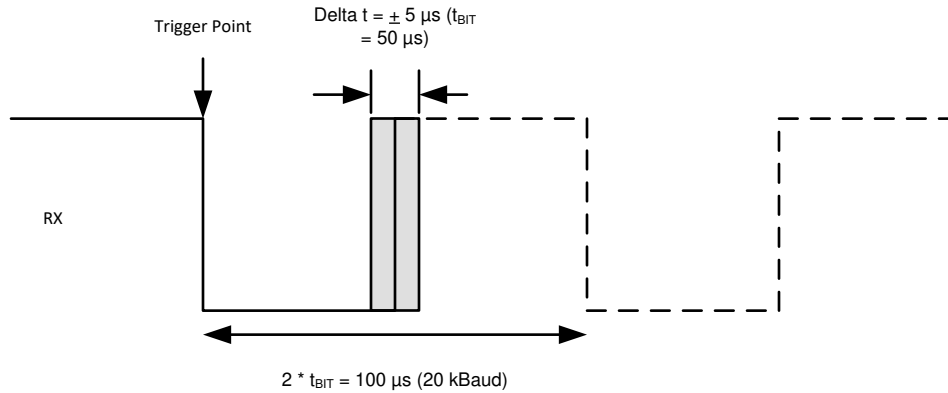

**8-2. RX Response: Operating Voltage Range**

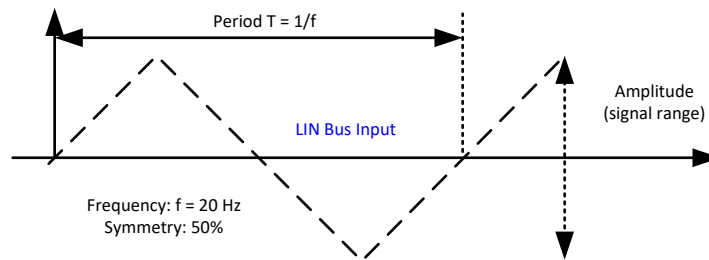

**8-3. LIN Bus Input Signal**

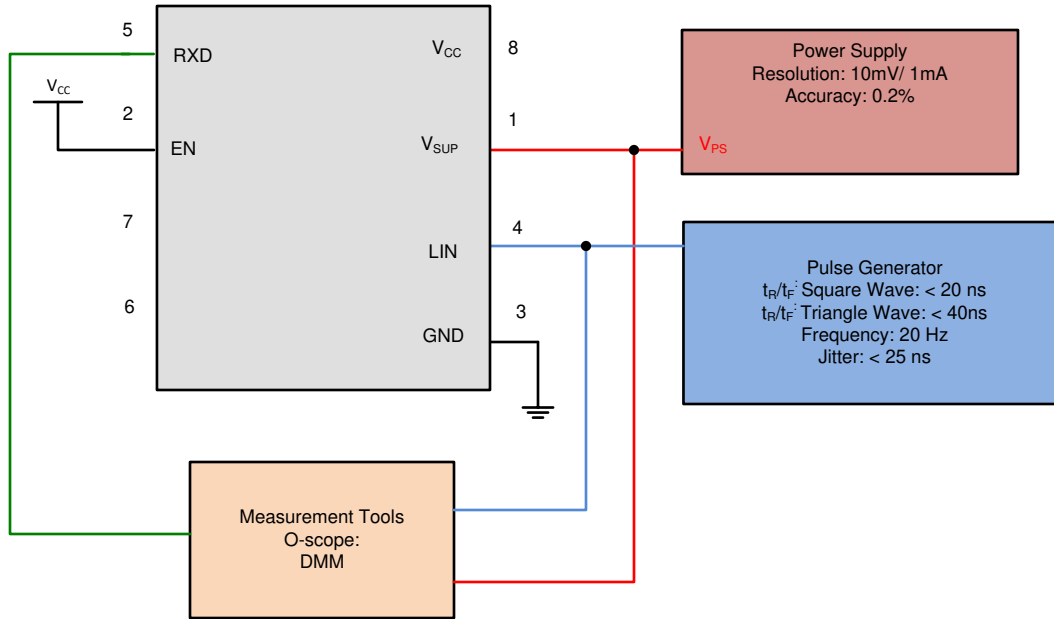

**8-4. LIN Receiver Test with RX access**

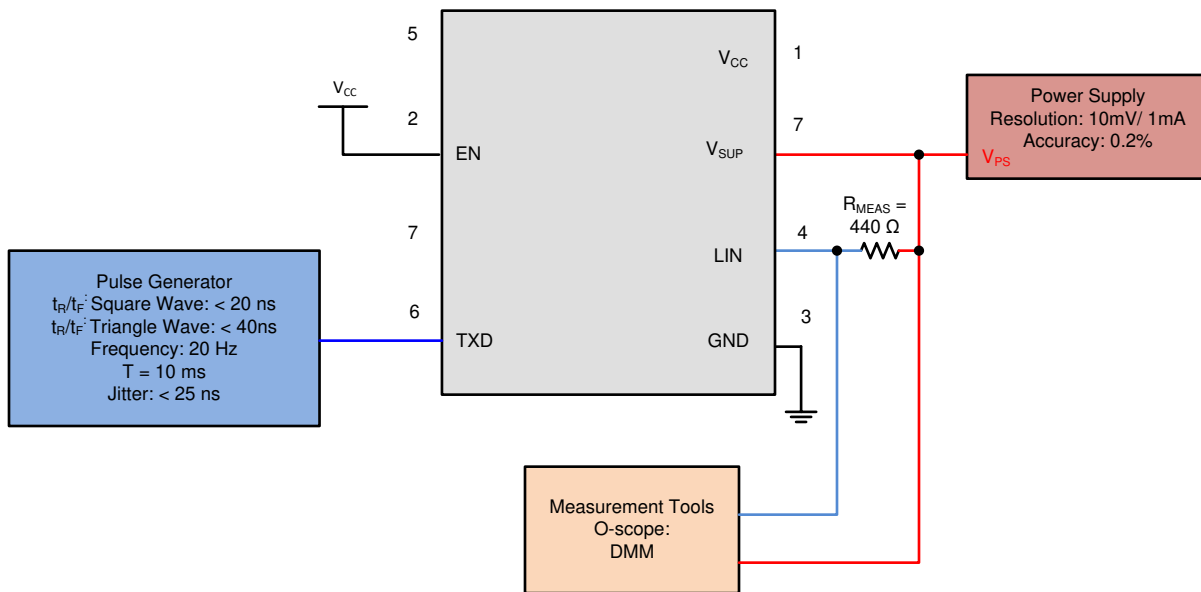

**8-5. Test Circuit for  $I_{BUS\_LIM}$  at Dominant State (Driver on)**

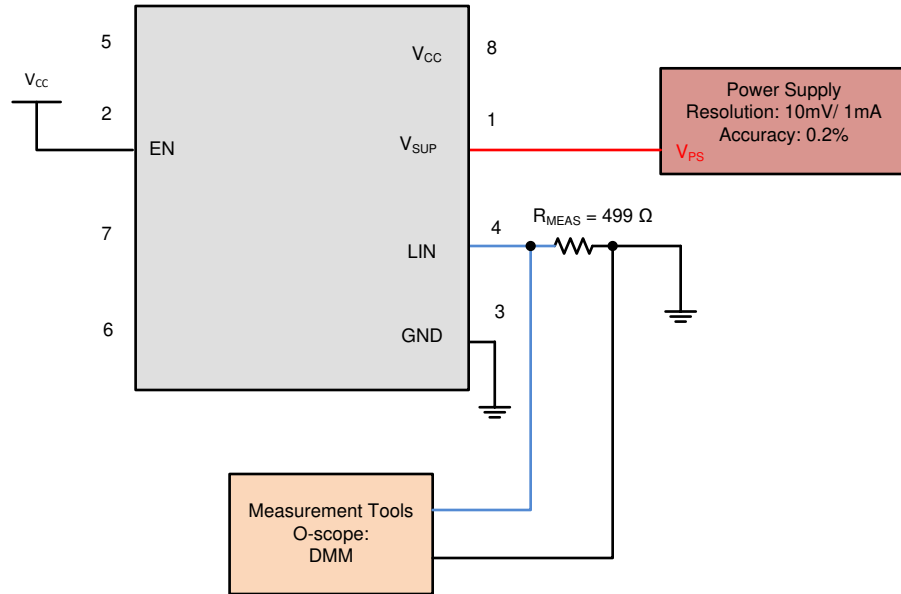

**8-6. Test Circuit for  $I_{BUS\_PAS\_dom}$ ; TXD = Recessive State  $V_{BUS} = 0 V$**

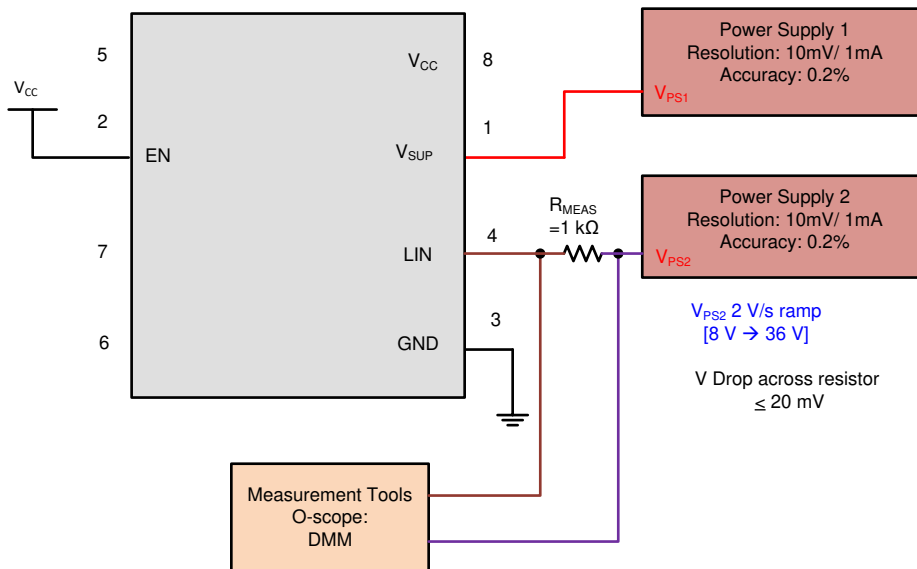

**8-7. Test Circuit for  $I_{BUS\_PAS\_rec}$**

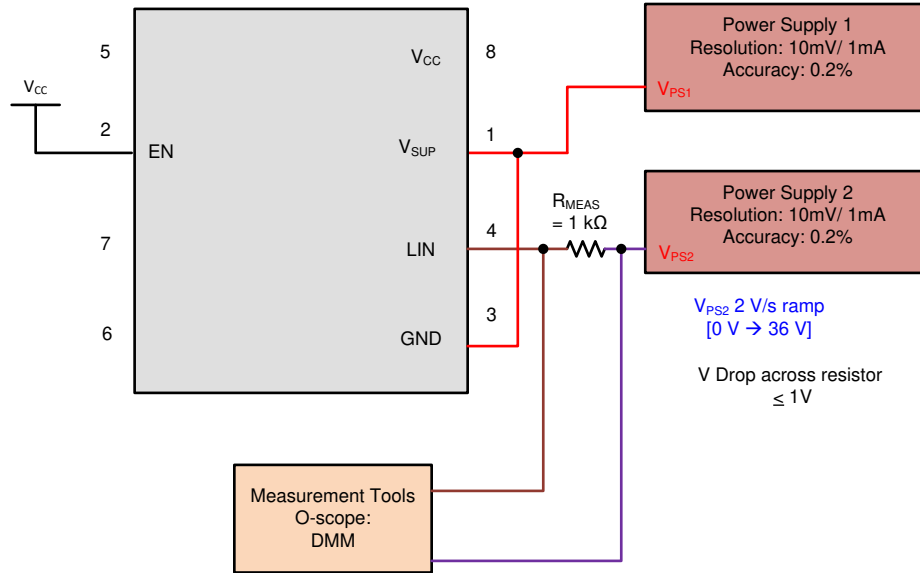

**8-8. Test Circuit for  $I_{BUS\_NO\_GND}$  Loss of GND**

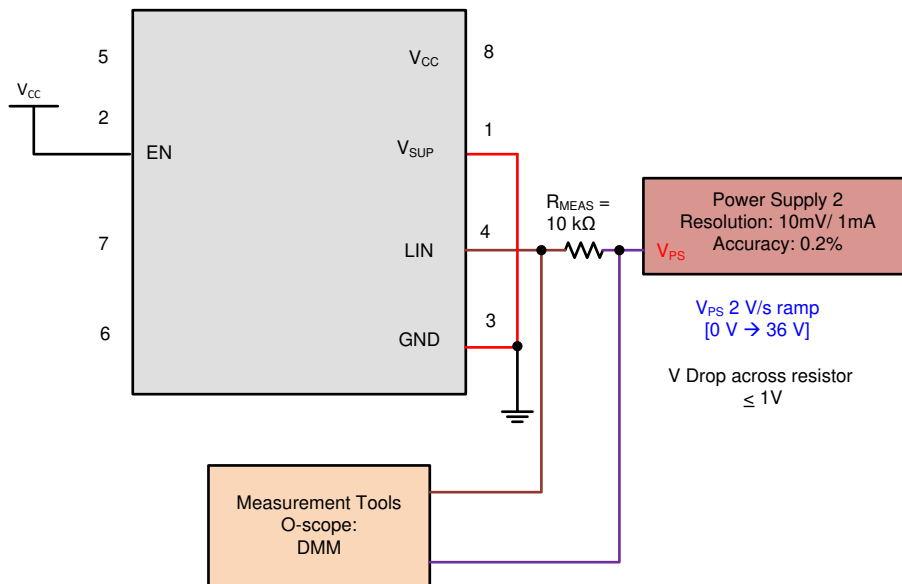

**8-9. Test Circuit for  $I_{BUS\_NO\_BAT}$  Loss of Battery**

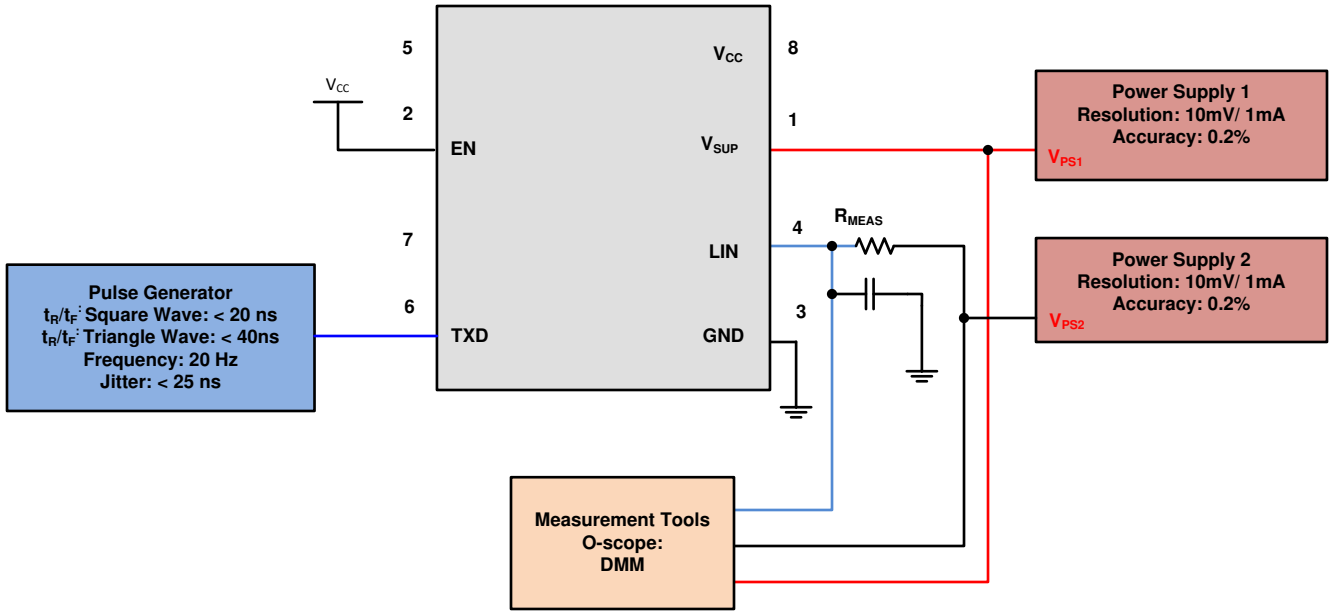

8-10. Test Circuit Slope Control and Duty Cycle

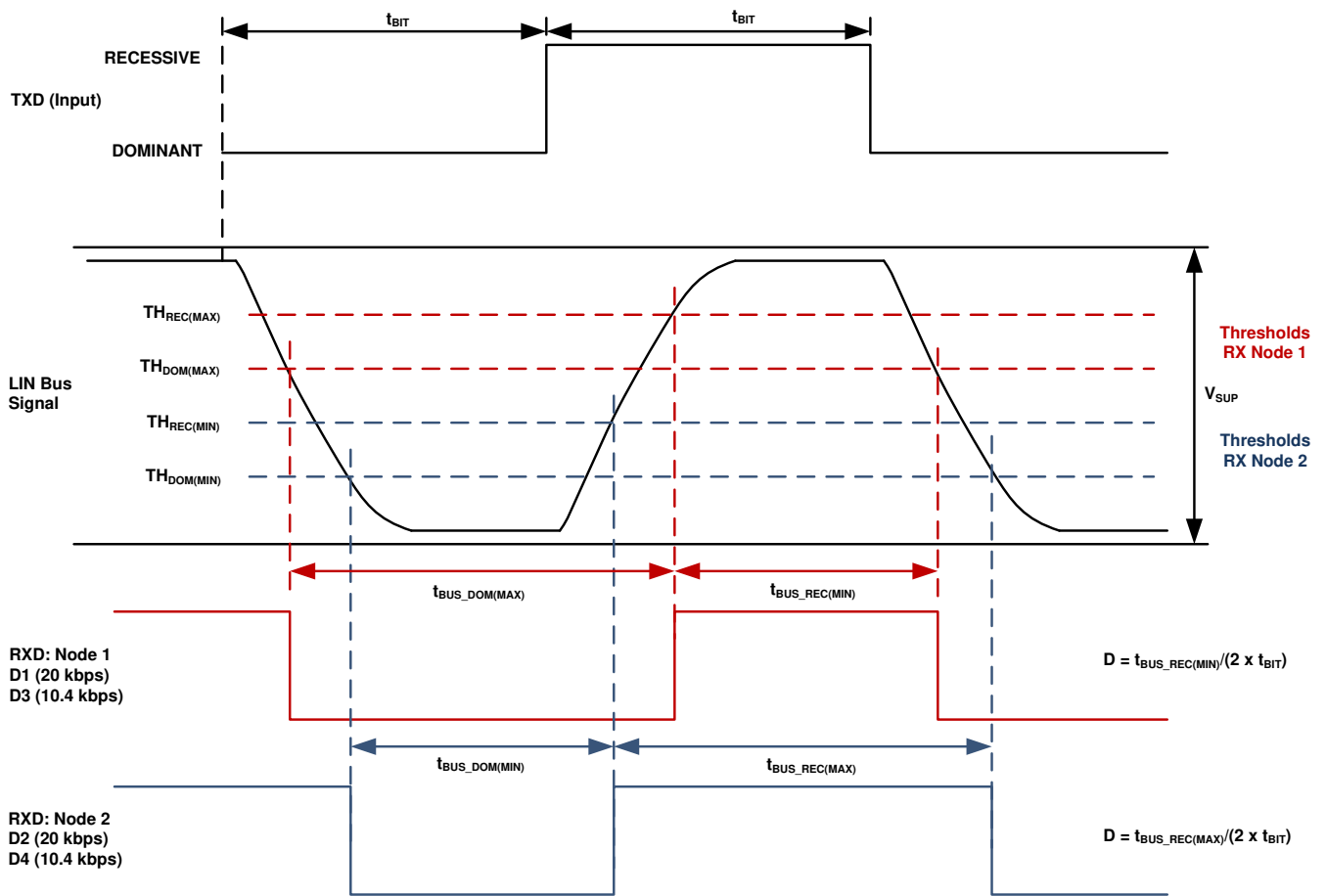

8-11. Definition of Bus Timing

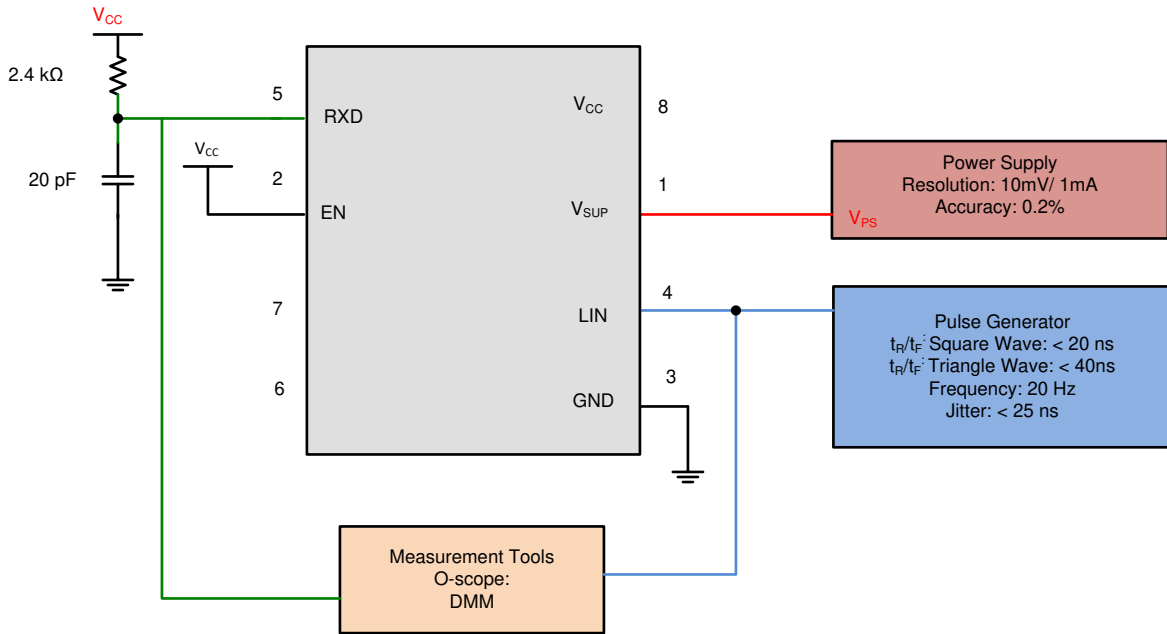

8-12. Propagation Delay Test Circuit

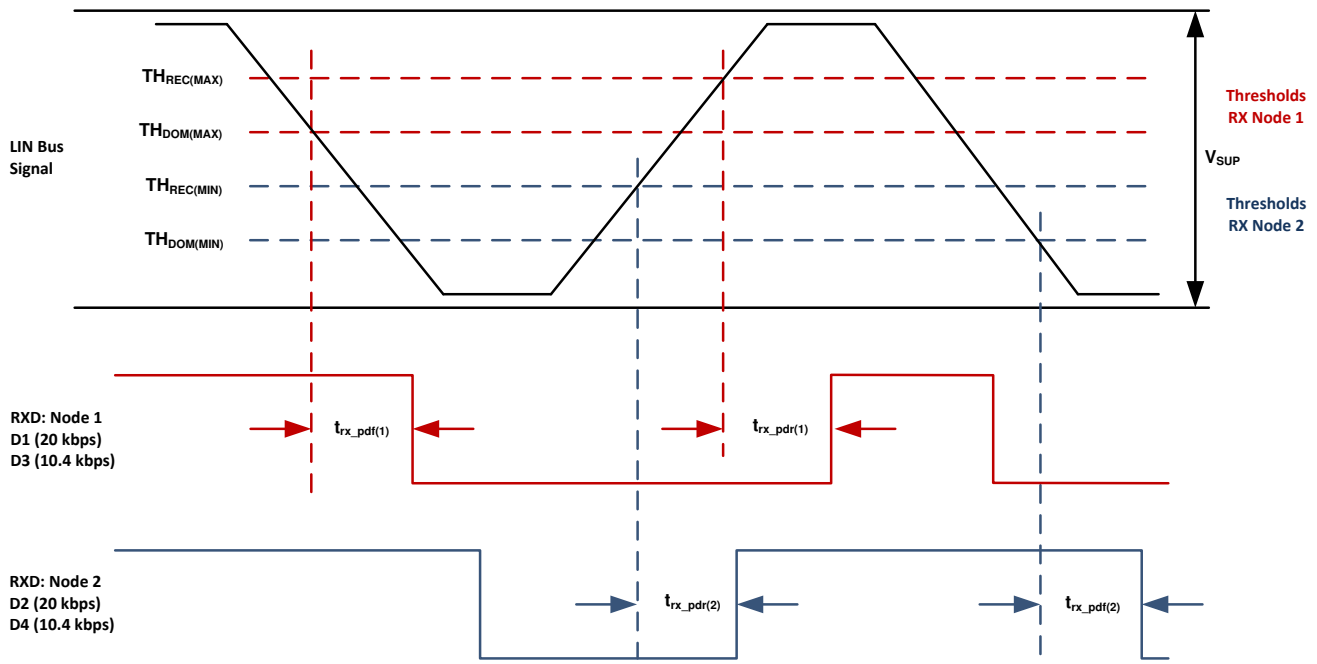

Copyright © 2017, Texas Instruments Incorporated

8-13. Propagation Delay



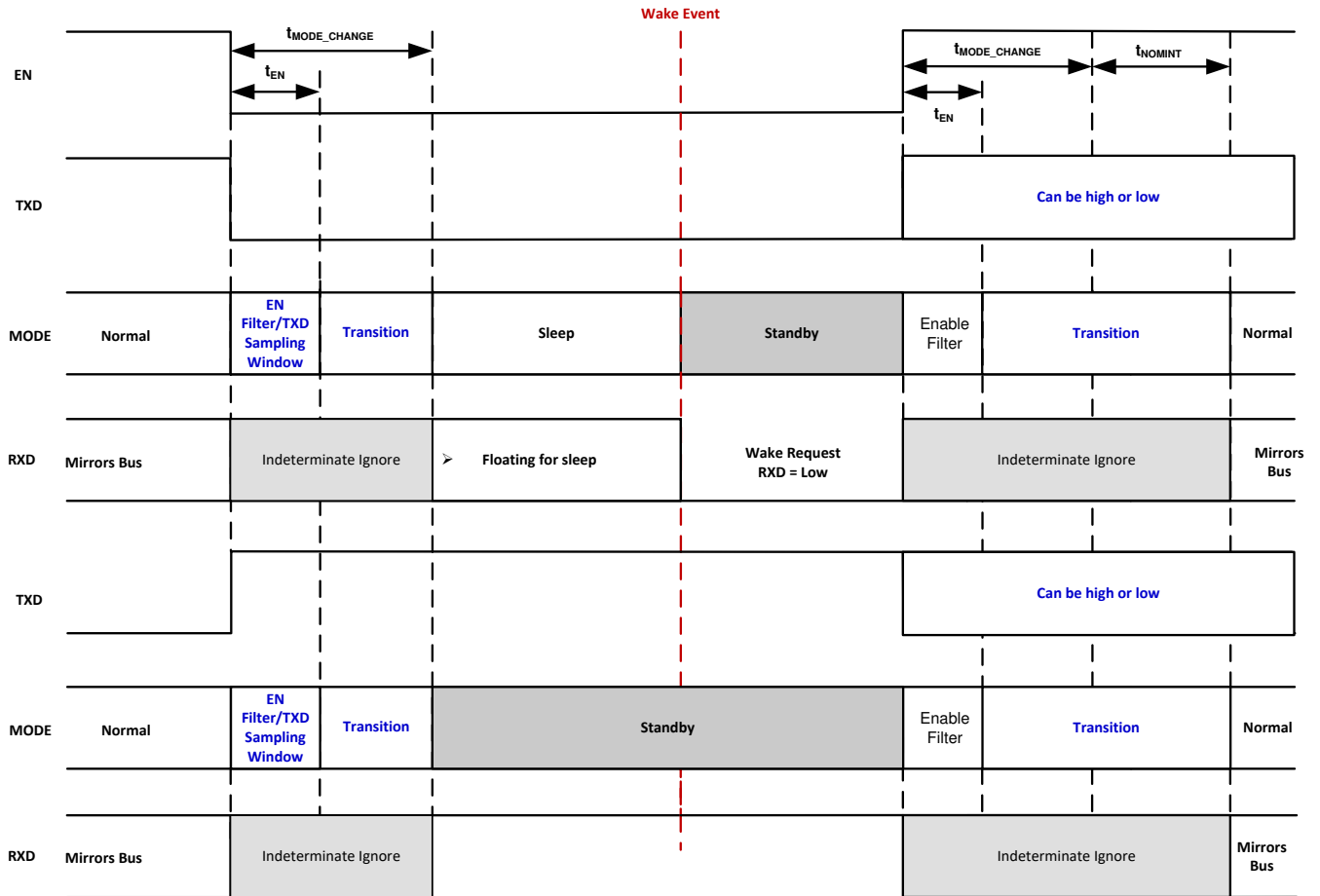

**8-14. Mode Transitions**

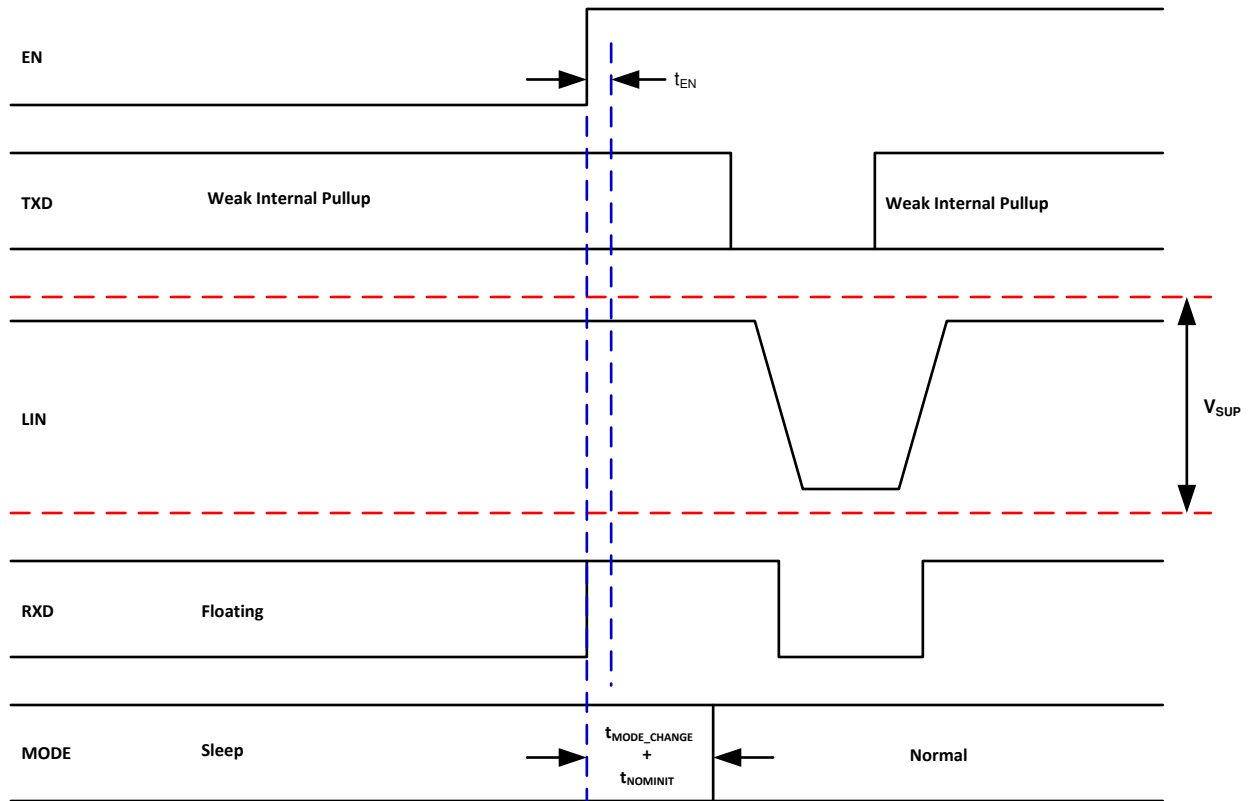

8-15. Wakeup Through EN

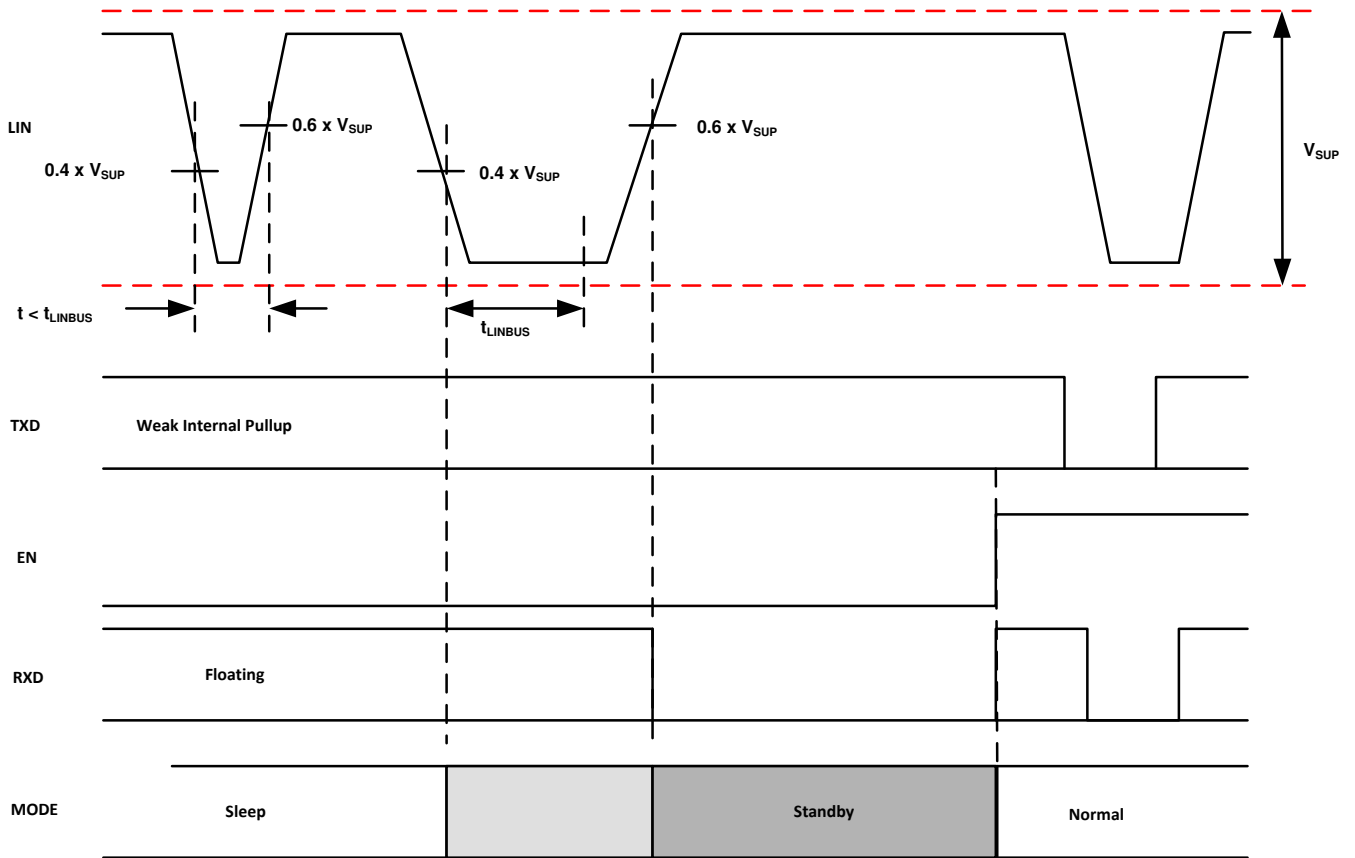

**8-16. Wakeup through LIN**

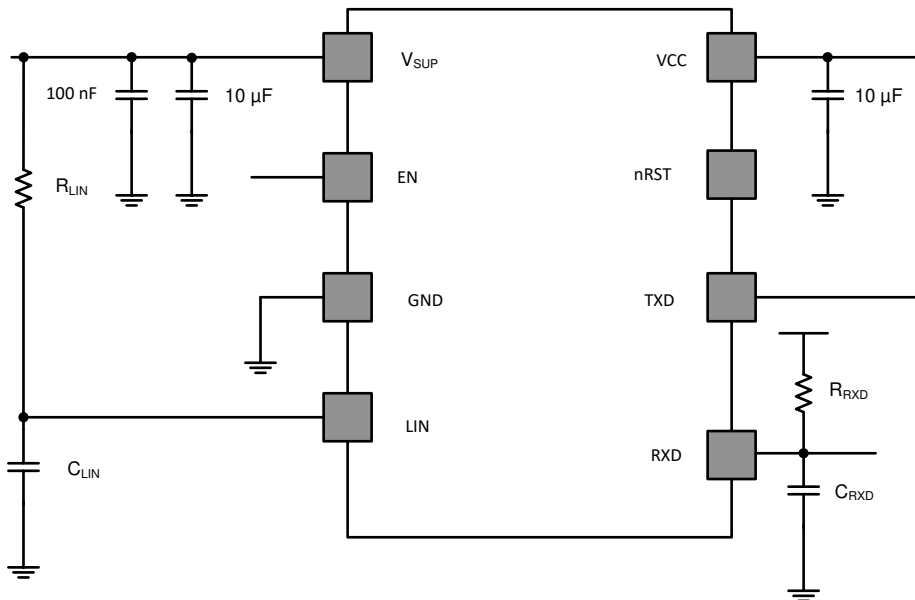

**8-17. Test Circuit for AC Characteristics**

## 9 Detailed Description

### 9.1 Overview

The TLIN1028S-Q1 LIN transceiver is a Local Interconnect Network (LIN) physical layer transceiver, compliant to LIN 2.0, LIN 2.1, LIN 2.2, LIN 2.2A and ISO/DIS 17987–4 with integrated wake-up and protection features. The LIN bus is a single-wire, bidirectional bus that typically is used in low-speed in-vehicle networks with data rates that range up to 20 kbps. The LIN receiver works up to 100 kbps supporting in-line programming. The device converts the LIN protocol data stream on the TXD input into a LIN bus signal using a current-limited wave-shaping driver which reduces electromagnetic emissions (EME). The receiver converts the data stream to logic-level signals that are sent to the microprocessor through the open-drain RXD pin. The LIN bus has two states: dominant state (voltage near ground) and recessive state (voltage near battery). In the recessive state, the LIN bus is pulled high by the internal pull-up resistor (45 k $\Omega$ ) and a series diode.

Ultra-low current consumption is possible using the sleep mode. The TLIN1028S-Q1 provides two methods to wake up from sleep mode: EN pin and LIN bus. The device integrates a low dropout voltage regulator with a wide input from  $V_{SUP}$  providing 5 V  $\pm$ 2% or 3.3 V  $\pm$ 2% with up to 70 mA of current depending upon system implementation. nRST is asserted high when  $V_{CC}$  increases above  $UV_{CC}$  and stays high as long as  $V_{CC}$  is above this threshold.

### 9.2 Functional Block Diagram

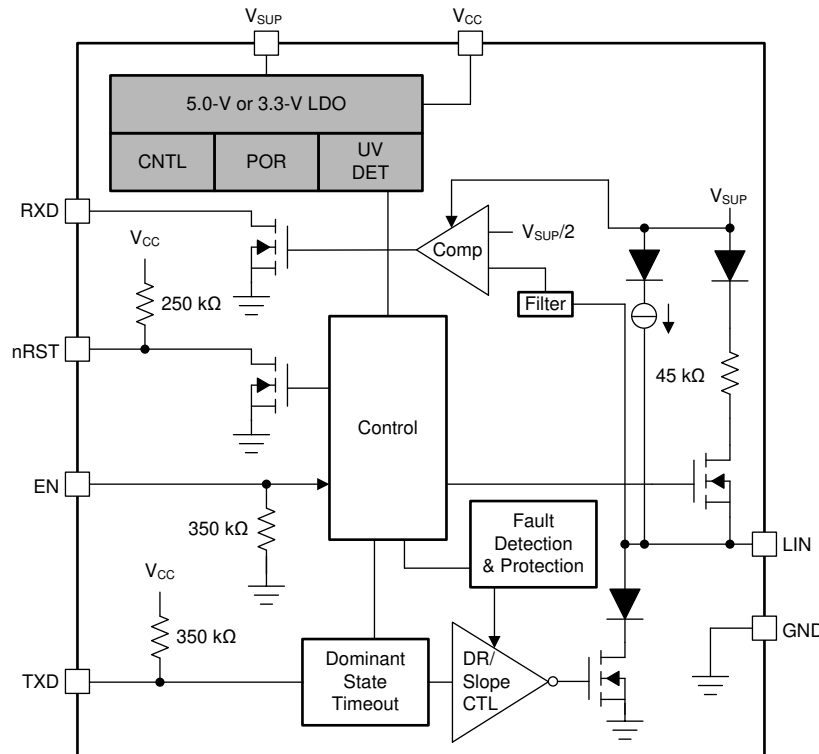

9-1. Functional Block Diagram

### 9.3 Feature Description

#### 9.3.1 LIN Pin

This high-voltage input or output pin is a single-wire LIN bus transmitter and receiver. The LIN pin can survive transient voltages up to 58 V. Reverse currents from the LIN to supply ( $V_{SUP}$ ) are minimized with blocking diodes, even in the event of a ground shift or loss of supply ( $V_{SUP}$ ).

### 9.3.1.1 LIN Transmitter Characteristics

The transmitter meets thresholds and AC parameters according to the LIN specification. The transmitter is a low-side transistor with internal current limitation and thermal shutdown. During a thermal shutdown condition, the transmitter is disabled to protect the device. There is an internal pull-up resistor with a serial diode structure to  $V_{SUP}$ , so no external pull-up components are required for the LIN responder node applications. An external pull-up resistor and series diode to  $V_{SUP}$  must be added when the device is used for a commander node application.

### 9.3.1.2 LIN Receiver Characteristics

The receiver characteristic thresholds are ratio-metric with the device supply pin according to the LIN specification.

The receiver is capable of receiving higher data rates ( $> 100$  kbps) than supported by LIN or SAEJ2602 specifications. This allows the TLIN1028S-Q1 to be used for high-speed downloads at the end-of-line production or other applications. The actual data rate achievable depends on system time constants (bus capacitance and pull-up resistance) and driver characteristics used in the system.

#### 9.3.1.2.1 Termination

There is an internal pull-up resistor with a serial diode structure to  $V_{SUP}$ , so no external pull-up components are required for the LIN responder node applications. An external pull-up resistor ( $1\text{ k}\Omega$ ) and a series diode to  $V_{SUP}$  must be added when the device is used for commander node applications as per the LIN specification.

Figure 9-2 shows a commander node configuration and how the voltage levels are defined

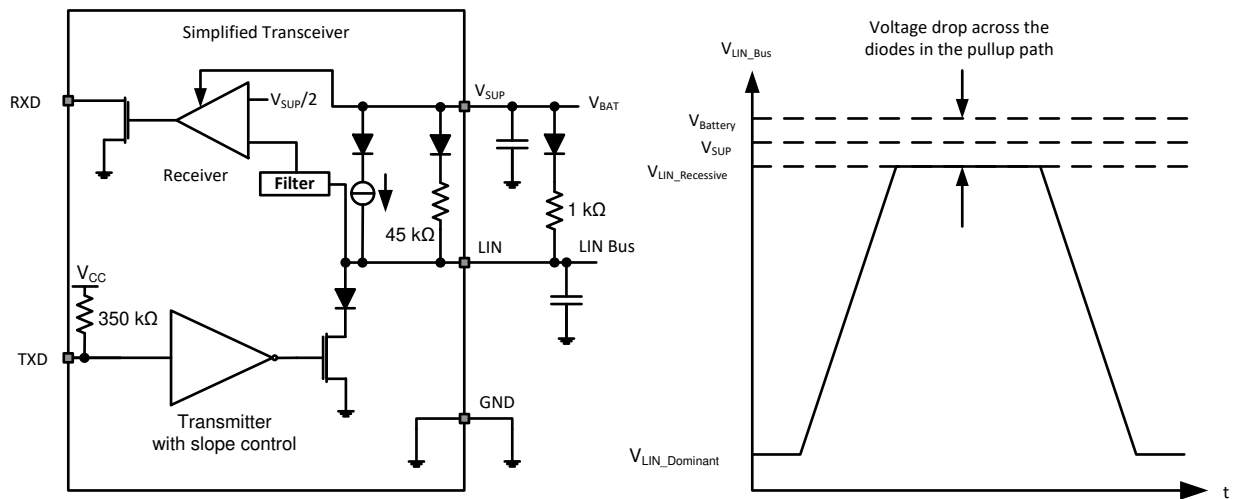

Figure 9-2. Commander Node Configuration with Voltage Levels

### 9.3.2 TXD (Transmit Input)

TXD is the interface to the node processor's LIN protocol controller that is used to control the state of the LIN output. When TXD is low, the LIN output is dominant (near ground). When TXD is high, the LIN output is recessive (near  $V_{SUP}$ ). See Figure 9-2. The TXD input structure is compatible with processors that use 3.3 V and 5 V  $V_I$  and  $V_O$ . TXD has an internal pull-up resistor. The LIN bus is protected from being stuck dominant through a system failure driving TXD low through the dominant state time-out timer.

### 9.3.3 RXD (Receive Output)

RXD is the interface to the processor's LIN protocol controller, which reports the state of the LIN bus voltage. LIN recessive (near  $V_{SUP}$ ) is represented by a high level on the RXD and LIN dominant (near ground) is represented by a low level on the RXD pin. The RXD output structure is an open-drain output stage. This allows the device to be used with 3.3 V and 5 V  $V_{I/O}$  processors. If the processor's RXD pin does not have an integrated pull-up, an external pull-up resistor to the processors I and O supply voltage is required. In standby mode, the RXD pin is driven low to indicate a wake-up request from the LIN bus from sleep mode. When going from normal mode to

standby mode, the RXD pin is released and pulled-up to the voltage rail that the external pull-up resistor is connected. A LIN bus wake event will cause the RXD pin to be pulled low indicating a wake request.

### 9.3.4 V<sub>SUP</sub> (Supply Voltage)

V<sub>SUP</sub> is the power supply pin. V<sub>SUP</sub> is connected to the battery through an external reverse-battery blocking diode.

The V<sub>SUP</sub> pin is a high-voltage-tolerant pin. A decoupling capacitor with a value of 100 nF is recommended to be connected close to this pin to improve the transient performance. If there is a loss of power at the ECU level, the device has ultra low leakage from the LIN pin, which does not load the bus down. This is optimal for LIN systems in which some of the nodes are unpowered (ignition supplied) while the rest of the network remains powered (battery supplied). When V<sub>SUP</sub> drops low enough the regulated output drops out of regulation. The LIN bus works with a V<sub>SUP</sub> as low as 5.5 V, but at a lower voltage, the performance is indeterminate and not ensured. If V<sub>SUP</sub> voltage level drops enough, it triggers the UV<sub>SUP</sub>, and if it keeps dropping, at some point it passes the POR threshold.

### 9.3.5 GND (Ground)

GND is the device ground connection. The device can operate with a ground shift as long as the ground shift does not reduce the V<sub>SUP</sub> below the minimum operating voltage. If there is a loss of ground at the ECU level, the device has ultra low leakage from the LIN pin, which does not load the bus down. This is optimal for LIN systems in which some of the nodes are unpowered (ignition supplied) while the rest of the network remains powered (battery supplied).

### 9.3.6 EN (Enable Input)

EN controls the operational modes of the device. When EN is high, the device is in normal operating mode allowing a transmission path from TXD to LIN and from LIN to RXD. When EN is low, the device is put into sleep or standby mode and there are no transmission paths available. EN has an internal pull-down resistor to ensure the device remains in low power mode even if EN is left floating. EN should be held low until V<sub>SUP</sub> reaches the expected system voltage level.

### 9.3.7 nRST (Reset Output)

The V<sub>CC</sub> pin is monitored for under voltage events. This pin is internally pulled up to V<sub>CC</sub> and when an undervoltage event takes place, this pin is pulled low. The pin returns to V<sub>CC</sub> once the voltage on V<sub>CC</sub> exceeds the under-voltage threshold. nRST is dependent on the value V<sub>CC</sub> and not the operational mode. If UV<sub>CC</sub> takes place for longer than t<sub>DET(UVCC)</sub> nRST is pulled to ground. If a thermal shutdown event takes place, this pin is pulled to ground.

### 9.3.8 V<sub>CC</sub> (Supply Output)

The V<sub>CC</sub> terminal can provide 5 V or 3.3 V with up to 70 mA to power up external devices when using high-k boards and thermal management best practices .

### 9.3.9 Protection Features

The device has several protection features that are described as follows.

#### 9.3.9.1 TXD Dominant Time Out (DTO)

During normal mode, if TXD is inadvertently driven permanently low by a hardware or software application failure, the LIN bus is protected by the dominant state time-out timer. This timer is triggered by a falling edge on the TXD pin. If the low signal remains on TXD for longer than t<sub>TXD\_DTO</sub>, the transmitter is disabled, thus allowing the LIN bus to return to recessive state and communication to resume on the bus. The protection is cleared and the t<sub>TXD\_DTO</sub> timer is reset by a rising edge on TXD. The TXD pin has an internal pull-up to ensure the device fails to a known recessive state if TXD is disconnected. During this fault, the transceiver remains in normal mode (assuming no change of state request on EN), the RXD pin reflects the LIN bus and the LIN bus pull-up termination remains on.

### 9.3.9.2 Bus Stuck Dominant System Fault: False Wake Up Lockout

The device contains logic to detect bus stuck dominant system faults and prevents the device from waking up falsely during the system fault. Upon entering sleep mode, the device detects the state of the LIN bus. If the bus is dominant, the wake-up logic is locked out until a valid recessive on the bus “clears” the bus stuck dominant, preventing excessive current use. [Figure 9-3](#) and [Figure 9-4](#) show the behavior of this protection.

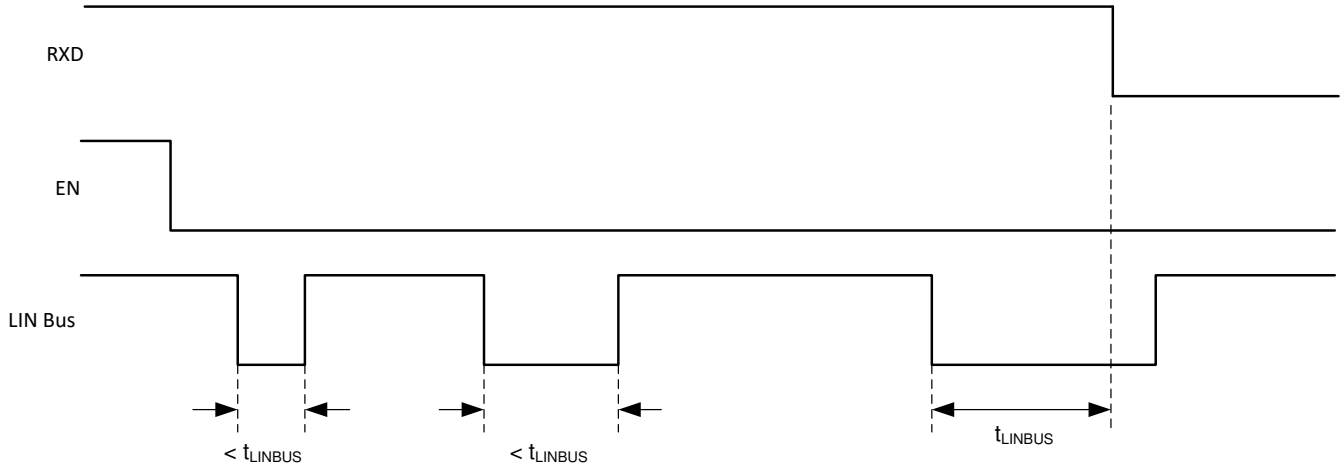

**Figure 9-3. No Bus Fault: Entering Sleep Mode with Bus Recessive Condition and Wakeup**

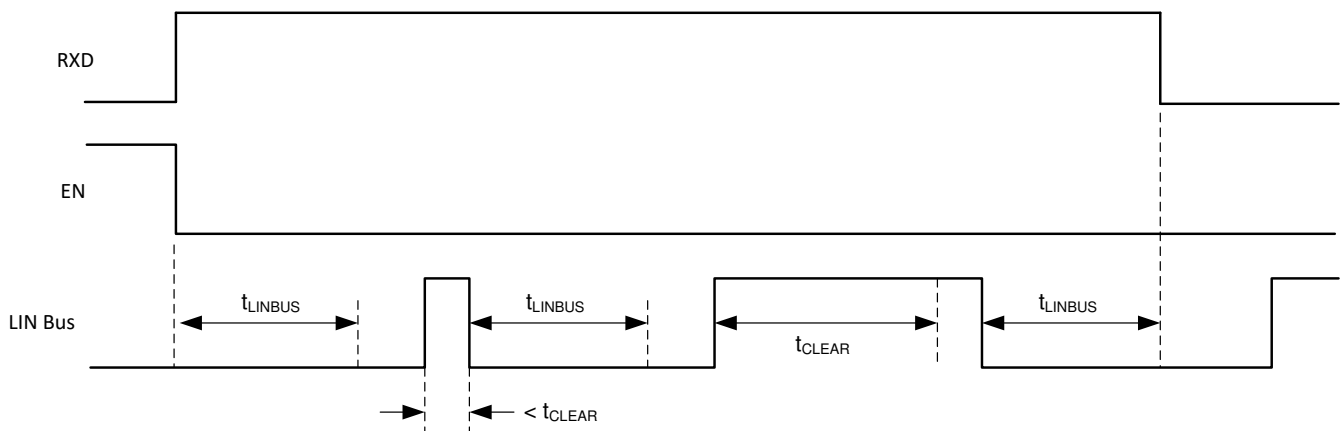

**Figure 9-4. Bus Fault: Entering Sleep Mode with Bus Stuck Dominant Fault, Clearing, and Wakeup**

### 9.3.9.3 Thermal Shutdown

The LIN transmitter is protected by current-limiting circuit; however, if the junction temperature of the device exceeds the thermal shutdown threshold, the device puts the LIN transmitter into the recessive state and turns off the  $V_{CC}$  regulator. The nRST pin is pulled to ground during a TSD event. Once the over-temperature fault condition has been removed and the virtual junction temperature has cooled beyond the hysteresis temperature, the transmitter is re-enabled. During this fault the device enters a TSD off mode. Once the junction temperature cools, the device enters standby mode as per the state diagram.

### 9.3.9.4 Under Voltage on $V_{SUP}$

The device contains a power-on reset circuit to avoid false bus messages during under voltage conditions when  $V_{SUP}$  is less than  $UV_{SUP}$ .

### 9.3.9.5 Unpowered Device and LIN Bus

In automotive applications, some LIN nodes in a system can be unpowered (ignition supplied) while others in the network remain powered by the battery. The device has extremely low unpowered leakage current from the bus, so an unpowered node does not affect the network nor load it down.

## 9.4 Device Functional Modes

nRST: Float

The TLIN1028S-Q1 has three functional modes of operation: normal, sleep, and standby. The next sections describes these modes as well as how the device moves between the different modes. [图 9-5](#) graphically shows the relationship while [表 9-1](#) shows the state of pins.

**表 9-1. Operating Modes**

Mode	EN	RXD	LIN BUS Termination	Transmitter	nRST	Comment
Sleep	Low	Floating	Weak Current pull-up	Off	Ground	nRST is internally connected to the LDO output which is pulled to ground in sleep mode.
Standby Init	Low	Floating	45 k $\Omega$ (typical)	Off	Ramping	nRST is internally connected to the LDO output which in standby init mode is pulled low until VCC raises beyond UV <sub>CC</sub> threshold.
Standby from SLP	Low	Low	45 k $\Omega$ (typical)	Off	V <sub>CC</sub>	Wake-up event detected, waiting on processors to set EN nRST comes on to V <sub>CC</sub> once thresholds are met.
Standby from Norm	Low	High	45 k $\Omega$ (typical)	Off	V <sub>CC</sub>	LDO is on and RXD is high
Normal	High	LIN Bus Data	45 k $\Omega$ (typical)	On	V <sub>CC</sub>	LIN transmission up to 20 kbps
TSD Off	NA	Floating	45 k $\Omega$ (typical)	Off	Ground	nRST is pulled low as the LDO is turned off which means UV <sub>CC</sub> threshold has been met.





图 9-5. Operating State Diagram

注

- RXD is latched low due to a wake event from sleep mode once entering standby mode
- RXD is high when entering standby mode from other modes and is not latch low for a wake event

#### 9.4.1 Normal Mode

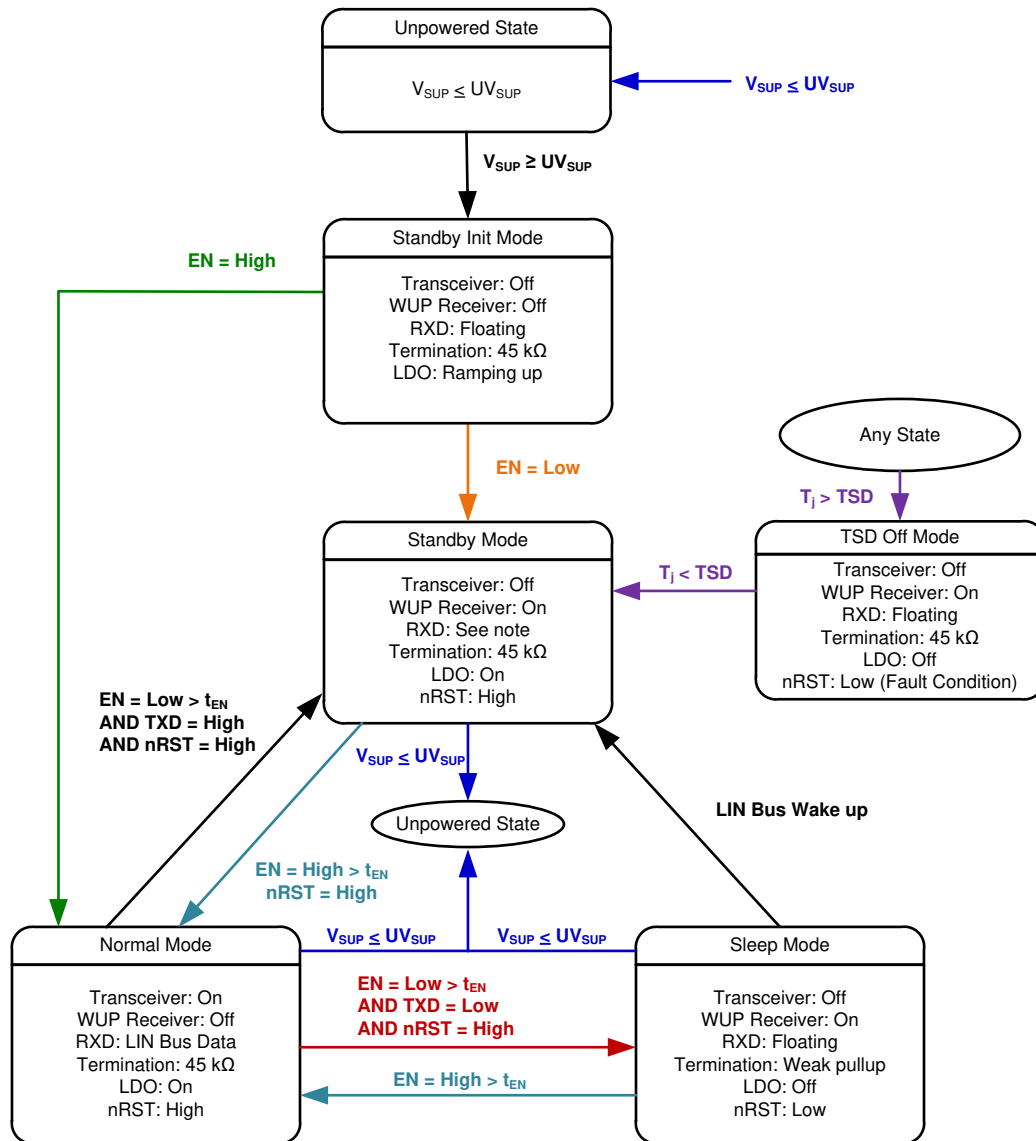
If the EN pin is high after the device enters standby init mode it enters normal mode. If EN is low, it enters standby mode. In normal operational mode, the receiver and transmitter are active and the LIN transmission up to the LIN specified maximum of 20 kbps is supported. The receiver detects the data stream on the LIN bus and outputs it on RXD for the LIN controller. A recessive signal on the LIN bus is a digital high and a dominant signal on the LIN bus is a digital low. The driver transmits input data from TXD to the LIN bus. Normal mode is entered as EN transitions high while the device is in sleep or standby mode for  $> t_{EN}$ . Once EN has been high for  $t_{EN}$  the device enters normal mode after  $t_{MODE\_CHANGE}$  and  $t_{NOMINIT}$ .

#### 9.4.2 Sleep Mode

While the device is in sleep mode, the following conditions exist:

- The LIN bus driver is disabled and the internal LIN bus termination is switched off (to minimize power loss if LIN is short-circuited to ground). However, the weak current pull-up is active to prevent false wake-up events in case an external connection to the LIN bus is lost.
- The normal receiver is disabled.
- EN input and LIN wake-up receiver are active.

### 9.4.3 Standby Mode

Standby mode is entered either by a wake up event through LIN bus while the device is in sleep mode or by the EN pin from normal or standby init modes. From normal mode EN must be low for  $> t_{EN}$  and TXD and nRST are high. RXD pin in standby mode is dependent upon how standby mode was entered. If entered from normal mode or power up, RXD is high. If entered from sleep mode, RXD is pulled low to indicate a wake event.

During power up, if EN is low the device goes into standby mode, and if EN is high, the device goes into normal mode. EN has an internal pull-down resistor ensuring EN is pulled low if the pin is left floating in the system.

### 9.4.4 Wake-Up Events

There are ways to wake-up from sleep mode:

- Remote wake-up initiated by the falling edge of a recessive (high) to dominant (low) state transition on the LIN bus where the dominant state is held for the  $t_{LINBUS}$  filter time. After this  $t_{LINBUS}$  filter time has been met and a rising edge on the LIN bus going from dominant state to recessive state initiates a remote wake-up event eliminating false wake ups from disturbances on the LIN bus or if the bus is shorted to ground.
- Local wake-up through EN being set high for longer than .

#### 9.4.4.1 Wake-Up Request (RXD)

When the TLIN1028S-Q1 encounters a wake-up event from the LIN bus, RXD goes low and the device transitions to standby mode until EN is reasserted high and the device enters normal mode. Once the device enters normal mode, the RXD pin releases the wake-up request signal and the RXD pin then reflects the receiver output from the LIN bus.

### 9.4.5 Mode Transitions

When the device is transitioning between modes, the device needs the time  $t_{MODE\_CHANGE}$  and  $t_{NOMINT}$  to allow the change to fully propagate from the EN pin through the device into the new state.

### 9.4.6 Voltage Regulator

The device has an integrated high-voltage LDO that operates over a 5.5 V to 28 V input voltage range for both 3.3 V and 5 V  $V_{CC}$ . The device has an output current capability of 70 mA and support fixed output voltages of 3.3 V (TLIN10283S-Q1) or 5 V (TLIN10285S-Q1). It features thermal shutdown and short-circuit protection to prevent damage during over-temperature and over-current conditions

#### 9.4.6.1 $V_{CC}$

The  $V_{CC}$  pin is the regulated output based on the required voltage. The regulated voltage accuracy is  $\pm 2\%$ . The output is current limited. In the event that the regulator drops out of regulation, the output tracks the input minus a drop based on the load current. When the input voltage drops below the  $UV_{SUP}$  threshold, the regulator shuts down until the input voltage returns above the  $UV_{SUPR}$  level. The device monitors situations where  $V_{CC}$  may drop below the  $UV_{CC}$  level thus causing the nRST pin to be pulled low.

#### 9.4.6.2 Output Capacitance Selection

For stable operation over the full temperature range and with load currents up to 70 mA on  $V_{CC}$  a certain capacitance is expected and depends upon the minimum load current. To support no load to full load a value of 10  $\mu F$  and ESR smaller than 2  $\Omega$  is needed. For 500  $\mu A$  to full load an 1  $\mu F$  capacitance can be used. The low ESR recommendation is to improve the load transient performance.

#### **9.4.6.3 Low-Voltage Tracking**

At low input voltages, the regulator drops out of regulation and the output voltage tracks input minus a voltage based on the load current (IL) and power-switch resistor. This tracking allows for a smaller input capacitance and can possibly eliminate the need for a boost converter during cold-crank conditions.

#### **9.4.6.4 Power Supply Recommendation**

The device is designed to operate from an input-voltage supply range between 5.5 V and 28 V. This input supply must be well regulated. If the input supply is located more than a few inches from the device. The recommended minimum capacitance at the pin is 100 nF . The max voltage range is for the LIN functionality. Exceeding 24V for the LDO reduces the effective current sourcing capability due to thermal considerations.

## 10 Application and Implementation

### 注

以下のアプリケーション情報は、TI の製品仕様に含まれるものではなく、TI ではその正確性または完全性を保証いたしません。個々の目的に対する製品の適合性については、お客様の責任で判断していただくこととなります。お客様は自身の設計実装を検証しテストすることで、システムの機能を確認する必要があります。

### 10.1 Application Information

The TLIN1028S-Q1 can be used as both a responder device and a commander device in a LIN network. The device comes with the ability to support a remote wake-up requests. It can provide the power to the local processor.

### 10.2 Typical Application

The device comes with an integrated 45 kΩ pull-up resistor and series diode for responder node applications. For commander node applications, an external 1 kΩ pull-up resistor with series blocking diode can be used. ☒

10-1

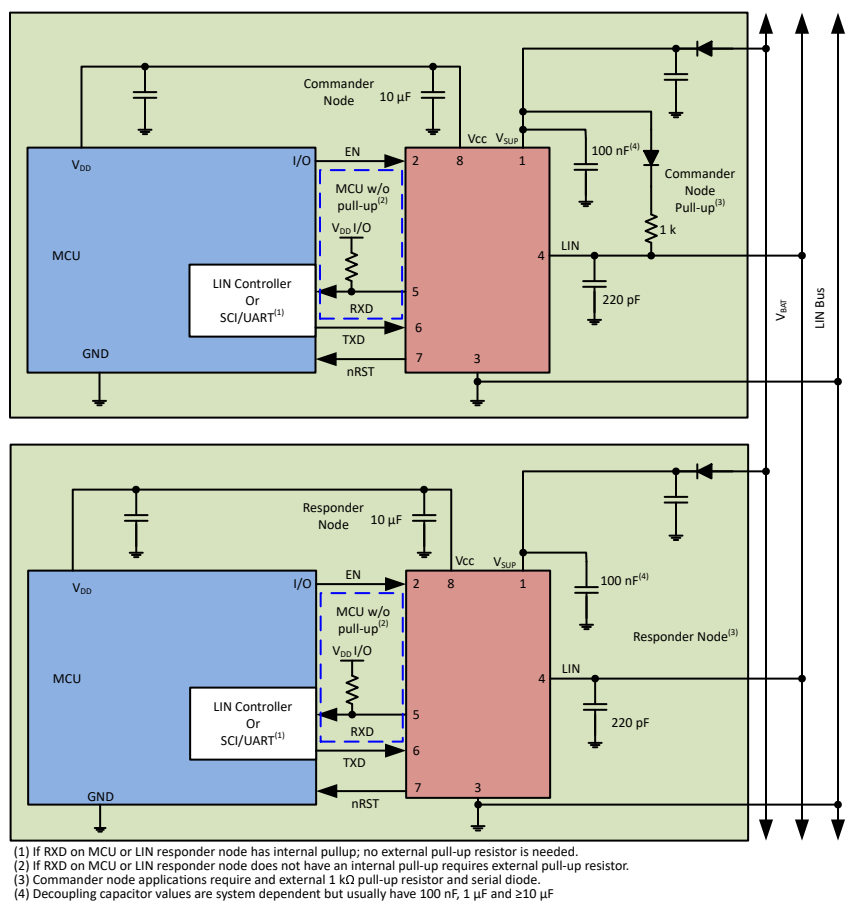

☒ 10-1. Typical LIN Bus

## 10.2.1 Design Requirements

### 10.2.1.1 Normal Mode Application Note

When using the TLIN1028S-Q1 in systems which are monitoring the RXD pin for a wake-up request, special care should be taken during the mode transitions. The output of the RXD pin is indeterminate for the transition period between states as the receivers are switched. The application software should not look for an edge on the RXD pin indicating a wake-up request until  $t_{\text{MODE\_CHANGE}}$ . This is shown in [Figure 8-14](#) when transitioning to normal mode there is an initialization period shown as  $t_{\text{NOMINIT}}$ .

### 10.2.1.2 TXD Dominant State Timeout Application Note

The maximum dominant TXD time allowed by the TXD dominant state time out limits the minimum possible data rate of the device. The LIN protocol has different constraints for commander and responder node applications; thus, there are different maximum consecutive dominant bits for each application case and thus different minimum data rates.

### 10.2.1.3 Brownout

[Figure 10-9](#) and [Figure 10-10](#) show the behavior of the LIN, nRST and  $V_{\text{CC}}$  pins during a brownout condition. For the TLIN10283S-Q1,  $V_{\text{SUP}}$  down to  $\sim 2.24$  V has results as shown. For the TLIN10285S-Q1,  $V_{\text{SUP}}$  down to  $\sim 2.63$  V has results as shown. When  $V_{\text{SUP}}$  drops below these levels the signals are indeterminate.

## 10.2.2 Detailed Design Procedures

For processors or LIN responder nodes with an internal pull-up on RXD, no external pull-up resistor is needed. For processors or LIN responder nodes without internal pull-up on RXD, an external pull-up resistor is required. Commander node applications require an external 1 k $\Omega$  pull-up resistor and serial diode.

### 10.2.3 Application Curves

Characteristic curves below show the LDO performance ramping between 0 V and up to 7 V.

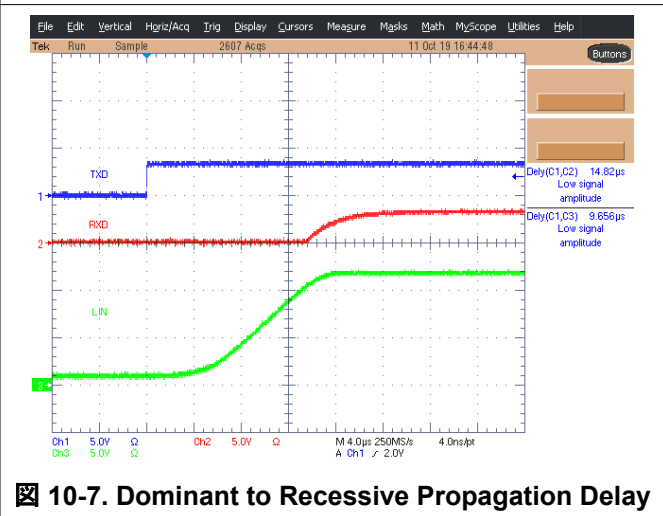
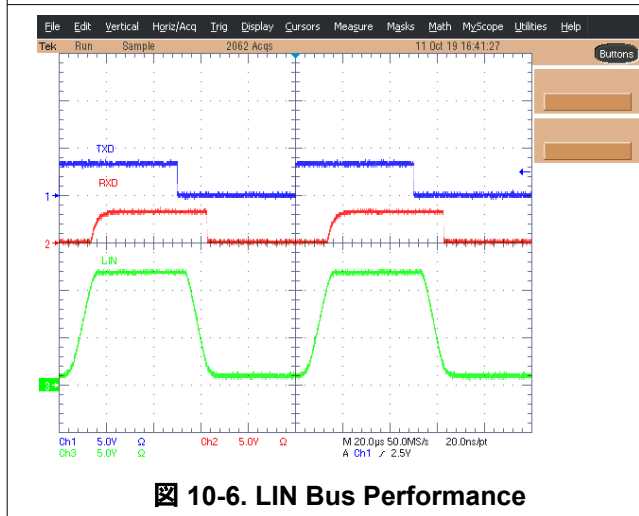
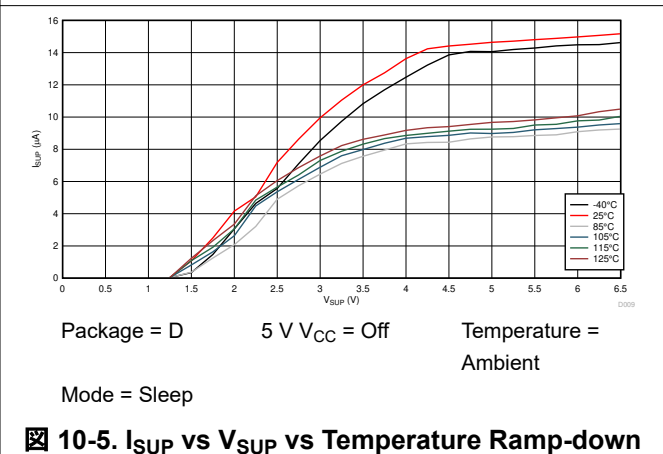
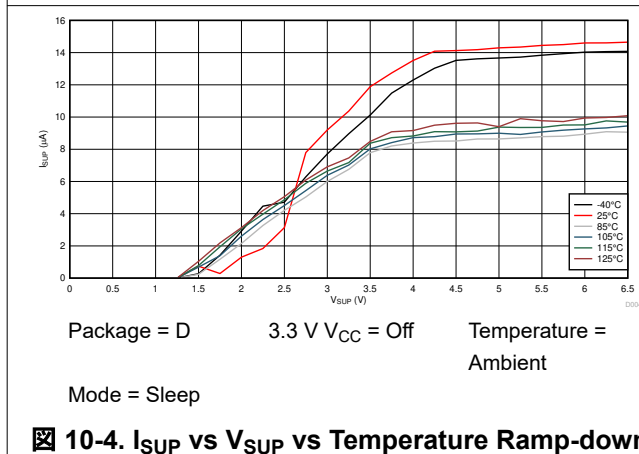
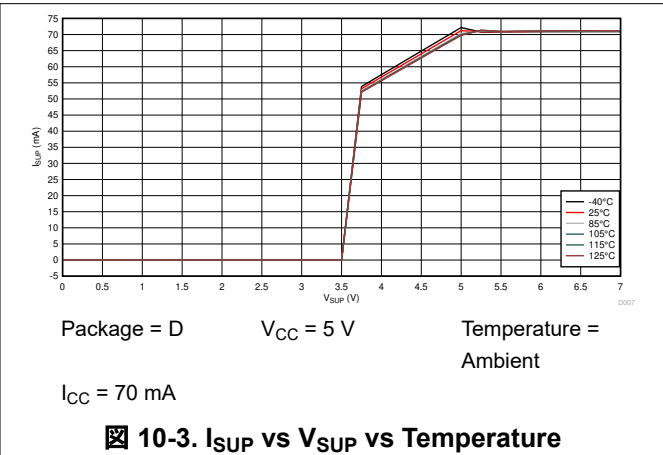
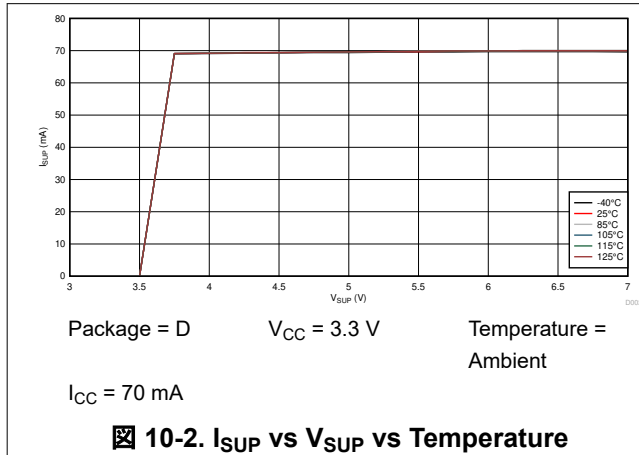

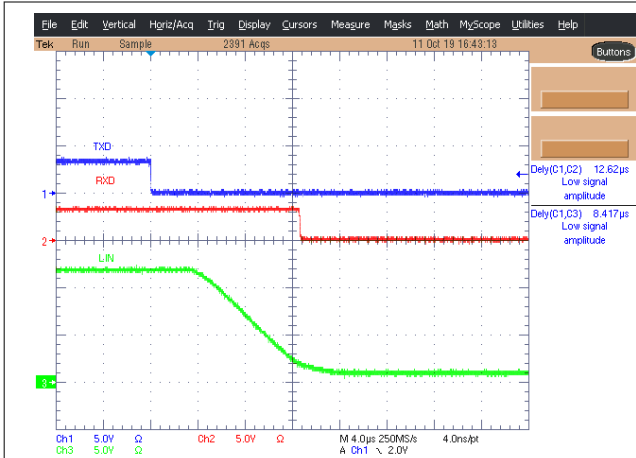

**10-8. Recessive to Dominant Propagation Delay**

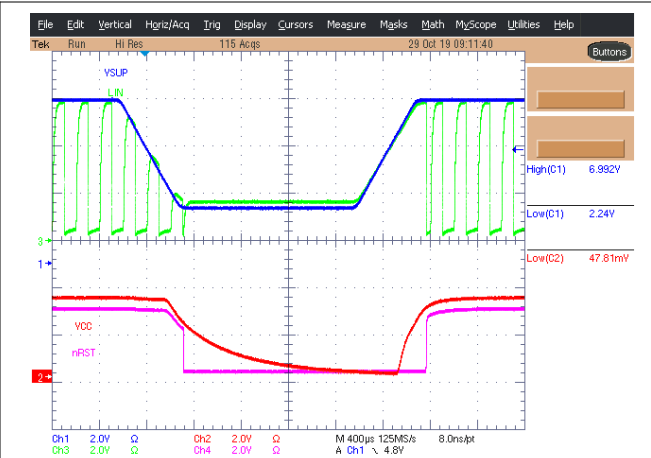

**10-9. TLIN10283S-Q1 Brownout**

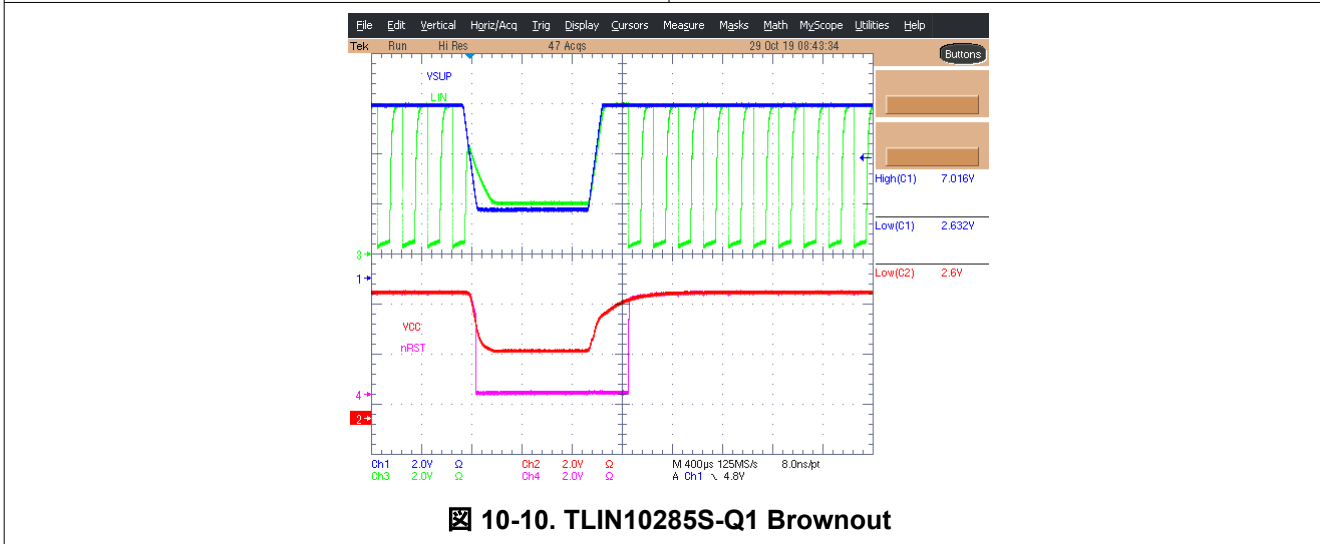

**10-10. TLIN10285S-Q1 Brownout**

## 11 Power Supply Recommendations

The TLIN1028S-Q1 was designed to operate directly off a car battery, or any other DC supply ranging from 5.5 V to 28 V . A 100 nF decoupling capacitor should be placed as close to the V<sub>SUP</sub> pin of the device as possible.

## 12 Layout

PCB design should start with understanding that frequency bandwidth from approximately 3 MHz to 3 GHz is needed thus high frequency layout techniques must be applied during PCB design. Placement at the connector also prevents these noisy events from propagating further into the PCB and system.

### 12.1 Layout Guidelines

- **Pin 1 (V<sub>SUP</sub>):** This is the supply pin for the device. A 100 nF decoupling capacitor should be placed as close to the device as possible.
- **Pin 2 (EN):** EN is an input pin that is used to place the device in a low power sleep mode. If this feature is not used, the pin should be pulled high to the regulated voltage supply of the microprocessor through a series resistor, values between 1 kΩ and 10 kΩ. Additionally, a series resistor may be placed on the pin to limit current on the digital lines in the event of an over-voltage fault.
- **Pin 3 (GND):** This is the ground connection for the device. This pin should be tied to the ground plane through a short trace with the use of two vias to limit total return inductance.
- **Pin 4 (LIN):** This pin connects to the LIN bus. For responder node applications, a 220 pF capacitor to ground is implemented. For commander node applications, an additional series resistor and blocking diode should be placed between the LIN pin and the V<sub>SUP</sub> pin. See [Figure 10-1](#)
- **Pin 5 (RXD):** The pin is an open-drain output and requires an external pull-up resistor in the range of 1 kΩ to 10 kΩ to function properly. If the microprocessor paired with the transceiver does not have an integrated pull-up, an external pull-up resistor should be placed on RXD. If RXD is connected to the V<sub>CC</sub> pin a higher pull-up resistor value can be used to reduce standby current.
- **Pin 6 (TXD):** The TXD pin is the transmit input signal to the device from the processors. A series resistor can be placed to limit the input current to the device in the event of an over voltage on this pin. A capacitor to ground can be placed close to the input pin of the device to filter noise.
- **Pin 7 (nRST):** This pin connects to the processors as a reset out.
- **Pin 8 (V<sub>CC</sub>):** Output source, either 3.3 V or 5 V depending upon the version of the device.

---

#### 注

All ground and power connections should be made as short as possible and use at least two vias to minimize the total loop inductance.

---



## 12.2 Layout Example

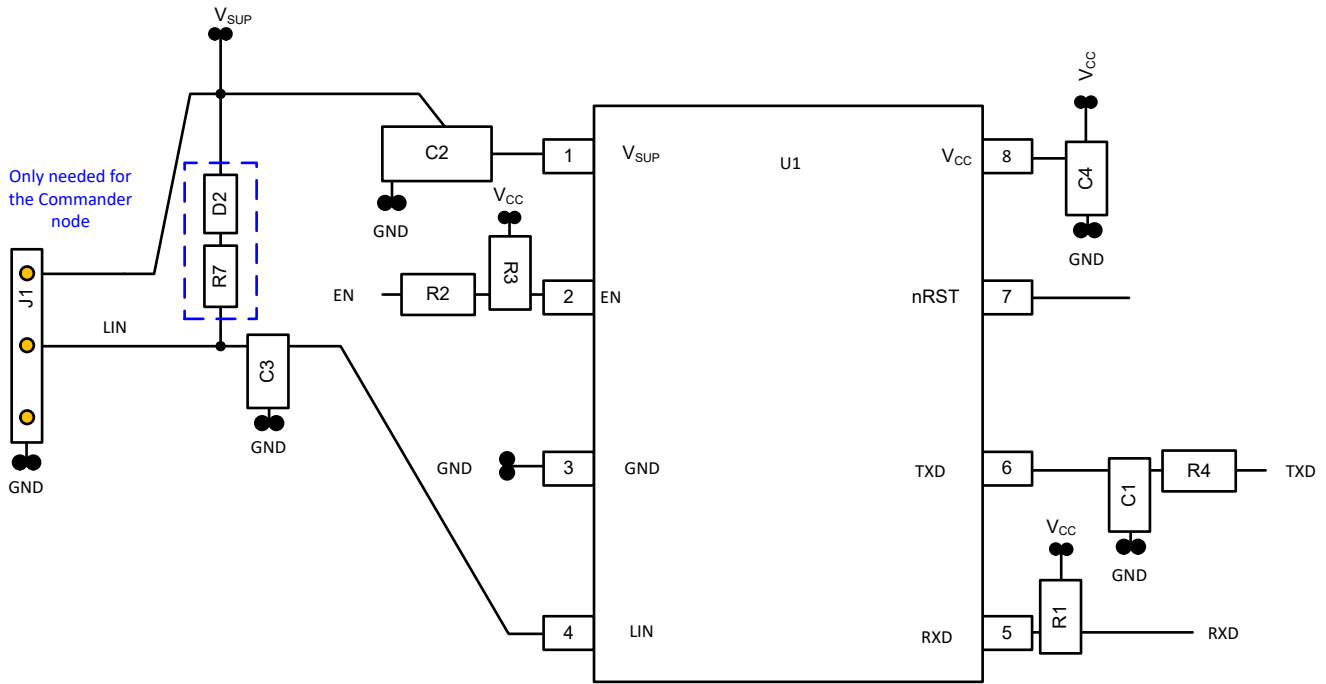

**12-1. Layout Example**

## 13 Device and Documentation Support

### 13.1 Documentation Support

#### 13.1.1 Related Documentation

##### [TLIN1028S-Q1 Duty Cycle Over \$V\_{SUP}\$](#)

For related documentation see the following:

- LIN Standards:
  - ISO/DIS 17987-1: Road vehicles -- Local Interconnect Network (LIN) -- Part 1: General information and use case definition
  - ISO/DIS 17987-4: Road vehicles -- Local Interconnect Network (LIN) -- Part 4: Electrical Physical Layer (EPL) specification 12V/24V
  - SAE J2602-1: LIN Network for Vehicle Applications
  - LIN2.0, LIN2.1, LIN2.2 and LIN2.2A specification
- EMC requirements:
  - SAE J2962-2: TBD
  - HW Requirements for CAN, LIN, FR V1.3: German OEM requirements for LIN
  - ISO 10605: Road vehicles - Test methods for electrical disturbances from electrostatic discharge
  - ISO 11452-4:2011: Road vehicles - Component test methods for electrical disturbances from narrowband radiated electromagnetic energy - Part 4: Harness excitation methods
  - ISO 7637-1:2015: Road vehicles - Electrical disturbances from conduction and coupling - Part 1: Definitions and general considerations
  - ISO 7637-3: Road vehicles - Electrical disturbances from conduction and coupling - Part 3: Electrical transient transmission by capacitive and inductive coupling via lines other than supply lines
  - IEC 62132-4:2006: Integrated circuits - Measurement of electromagnetic immunity 150 kHz to 1 GHz - Part 4: Direct RF power injection method
  - IEC 61967-4
  - CISPR25
- Conformance Test requirements:
  - ISO/DIS 17987-7: Road vehicles -- Local Interconnect Network (LIN) -- Part 7: Electrical Physical Layer (EPL) conformance test specification
  - SAE J2602-2: LIN Network for Vehicle Applications Conformance Test

##### [TLINx441 LDO Performance, SLLA427](#)

### 13.2 Receiving Notification of Documentation Updates

To receive notification of documentation updates, navigate to the device product folder on [ti.com](http://ti.com). Click on *Subscribe to updates* to register and receive a weekly digest of any product information that has changed. For change details, review the revision history included in any revised document.

### 13.3 サポート・リソース

TI E2E™ サポート・フォーラムは、エンジニアが検証済みの回答と設計に関するヒントをエキスパートから迅速かつ直接得ることができる場所です。既存の回答を検索したり、独自の質問をしたりすることで、設計に必要な支援を迅速に得ることができます。

リンクされているコンテンツは、該当する貢献者により、現状のまま提供されるものです。これらは TI の仕様を構成するものではなく、必ずしも TI の見解を反映したものではありません。TI の [使用条件](#) を参照してください。

### 13.4 Trademarks

TI E2E™ is a trademark of Texas Instruments.

すべての商標は、それぞれの所有者に帰属します。

### 13.5 Electrostatic Discharge Caution



This integrated circuit can be damaged by ESD. Texas Instruments recommends that all integrated circuits be handled with appropriate precautions. Failure to observe proper handling and installation procedures can cause damage.

ESD damage can range from subtle performance degradation to complete device failure. Precision integrated circuits may be more susceptible to damage because very small parametric changes could cause the device not to meet its published specifications.

### 13.6 Glossary

[TI Glossary](#) This glossary lists and explains terms, acronyms, and definitions.

### 14 Mechanical, Packaging, and Orderable Information

The following pages include mechanical, packaging, and orderable information. This information is the most current data available for the designated devices. This data is subject to change without notice and revision of this document. For browser-based versions of this data sheet, refer to the left-hand navigation.

**PACKAGING INFORMATION**

Orderable Device	Status (1)	Package Type	Package Drawing	Pins	Package Qty	Eco Plan (2)	Lead finish/ Ball material (6)	MSL Peak Temp (3)	Op Temp (°C)	Device Marking (4/5)	Samples
TLIN10283SDRQ1	ACTIVE	SOIC	D	8	2500	RoHS & Green	NIPDAU	Level-1-260C-UNLIM	-40 to 125	TL083	<a href="#">Samples</a>
TLIN10285SDRQ1	ACTIVE	SOIC	D	8	2500	RoHS & Green	NIPDAU	Level-1-260C-UNLIM	-40 to 125	TL085	<a href="#">Samples</a>

(1) The marketing status values are defined as follows:

**ACTIVE:** Product device recommended for new designs.

**LIFEBUY:** TI has announced that the device will be discontinued, and a lifetime-buy period is in effect.

**NRND:** Not recommended for new designs. Device is in production to support existing customers, but TI does not recommend using this part in a new design.

**PREVIEW:** Device has been announced but is not in production. Samples may or may not be available.

**OBSOLETE:** TI has discontinued the production of the device.

(2) **RoHS:** TI defines "RoHS" to mean semiconductor products that are compliant with the current EU RoHS requirements for all 10 RoHS substances, including the requirement that RoHS substance do not exceed 0.1% by weight in homogeneous materials. Where designed to be soldered at high temperatures, "RoHS" products are suitable for use in specified lead-free processes. TI may reference these types of products as "Pb-Free".

**RoHS Exempt:** TI defines "RoHS Exempt" to mean products that contain lead but are compliant with EU RoHS pursuant to a specific EU RoHS exemption.

**Green:** TI defines "Green" to mean the content of Chlorine (Cl) and Bromine (Br) based flame retardants meet JS709B low halogen requirements of <=1000ppm threshold. Antimony trioxide based flame retardants must also meet the <=1000ppm threshold requirement.

(3) MSL, Peak Temp. - The Moisture Sensitivity Level rating according to the JEDEC industry standard classifications, and peak solder temperature.

(4) There may be additional marking, which relates to the logo, the lot trace code information, or the environmental category on the device.

(5) Multiple Device Markings will be inside parentheses. Only one Device Marking contained in parentheses and separated by a "~" will appear on a device. If a line is indented then it is a continuation of the previous line and the two combined represent the entire Device Marking for that device.

(6) Lead finish/Ball material - Orderable Devices may have multiple material finish options. Finish options are separated by a vertical ruled line. Lead finish/Ball material values may wrap to two lines if the finish value exceeds the maximum column width.

**Important Information and Disclaimer:**The information provided on this page represents TI's knowledge and belief as of the date that it is provided. TI bases its knowledge and belief on information provided by third parties, and makes no representation or warranty as to the accuracy of such information. Efforts are underway to better integrate information from third parties. TI has taken and continues to take reasonable steps to provide representative and accurate information but may not have conducted destructive testing or chemical analysis on incoming materials and chemicals. TI and TI suppliers consider certain information to be proprietary, and thus CAS numbers and other limited information may not be available for release.

In no event shall TI's liability arising out of such information exceed the total purchase price of the TI part(s) at issue in this document sold by TI to Customer on an annual basis.



**TAPE AND REEL INFORMATION**

**QUADRANT ASSIGNMENTS FOR PIN 1 ORIENTATION IN TAPE**

\*All dimensions are nominal

Device	Package Type	Package Drawing	Pins	SPQ	Reel Diameter (mm)	Reel Width W1 (mm)	A0 (mm)	B0 (mm)	K0 (mm)	P1 (mm)	W (mm)	Pin1 Quadrant
TLIN10283SDRQ1	SOIC	D	8	2500	330.0	12.4	6.4	5.2	2.1	8.0	12.0	Q1
TLIN10285SDRQ1	SOIC	D	8	2500	330.0	12.4	6.4	5.2	2.1	8.0	12.0	Q1

**TAPE AND REEL BOX DIMENSIONS**

\*All dimensions are nominal

Device	Package Type	Package Drawing	Pins	SPQ	Length (mm)	Width (mm)	Height (mm)
TLIN10283SDRQ1	SOIC	D	8	2500	356.0	356.0	35.0
TLIN10285SDRQ1	SOIC	D	8	2500	356.0	356.0	35.0



D0008A

# PACKAGE OUTLINE

SOIC - 1.75 mm max height

SMALL OUTLINE INTEGRATED CIRCUIT



4214825/C 02/2019

### NOTES:

- Linear dimensions are in inches [millimeters]. Dimensions in parenthesis are for reference only. Controlling dimensions are in inches. Dimensioning and tolerancing per ASME Y14.5M.
- This drawing is subject to change without notice.
- This dimension does not include mold flash, protrusions, or gate burrs. Mold flash, protrusions, or gate burrs shall not exceed  $.006$  [0.15] per side.
- This dimension does not include interlead flash.
- Reference JEDEC registration MS-012, variation AA.



# EXAMPLE BOARD LAYOUT

D0008A

SOIC - 1.75 mm max height

SMALL OUTLINE INTEGRATED CIRCUIT



LAND PATTERN EXAMPLE  
 EXPOSED METAL SHOWN  
 SCALE:8X



SOLDER MASK DETAILS

4214825/C 02/2019

NOTES: (continued)

- 6. Publication IPC-7351 may have alternate designs.
- 7. Solder mask tolerances between and around signal pads can vary based on board fabrication site.

# EXAMPLE STENCIL DESIGN

D0008A

SOIC - 1.75 mm max height

SMALL OUTLINE INTEGRATED CIRCUIT



SOLDER PASTE EXAMPLE  
BASED ON .005 INCH [0.125 MM] THICK STENCIL  
SCALE:8X

4214825/C 02/2019

NOTES: (continued)

8. Laser cutting apertures with trapezoidal walls and rounded corners may offer better paste release. IPC-7525 may have alternate design recommendations.
9. Board assembly site may have different recommendations for stencil design.

## 重要なお知らせと免責事項

TI は、技術データと信頼性データ(データシートを含みます)、設計リソース(リファレンス・デザインを含みます)、アプリケーションや設計に関する各種アドバイス、Web ツール、安全性情報、その他のリソースを、欠陥が存在する可能性のある「現状のまま」提供しており、商品性および特定目的に対する適合性の黙示保証、第三者の知的財産権の非侵害保証を含むいかなる保証も、明示的または黙示的にかかわらず拒否します。

これらのリソースは、TI 製品を使用する設計の経験を積んだ開発者への提供を意図したものです。(1) お客様のアプリケーションに適した TI 製品の選定、(2) お客様のアプリケーションの設計、検証、試験、(3) お客様のアプリケーションに該当する各種規格や、その他のあらゆる安全性、セキュリティ、規制、または他の要件への確実な適合に関する責任を、お客様のみが単独で負うものとし、

上記の各種リソースは、予告なく変更される可能性があります。これらのリソースは、リソースで説明されている TI 製品を使用するアプリケーションの開発の目的でのみ、TI はその使用をお客様に許諾します。これらのリソースに関して、他の目的で複製することや掲載することは禁止されています。TI や第三者の知的財産権のライセンスが付与されている訳ではありません。お客様は、これらのリソースを自身で使用した結果発生するあらゆる申し立て、損害、費用、損失、責任について、TI およびその代理人を完全に補償するものとし、TI は一切の責任を拒否します。

TI の製品は、[TI の販売条件](#)、または [ti.com](https://www.ti.com) やかかる TI 製品の関連資料などのいずれかを通じて提供する適用可能な条項の下で提供されています。TI がこれらのリソースを提供することは、適用される TI の保証または他の保証の放棄の拡大や変更を意味するものではありません。

お客様がいかなる追加条項または代替条項を提案した場合でも、TI はそれらに異議を唱え、拒否します。

郵送先住所 : Texas Instruments, Post Office Box 655303, Dallas, Texas 75265

Copyright © 2022, Texas Instruments Incorporated