

Table of Contents

1 特長	1	9.2 Functional Block Diagram.....	23
2 アプリケーション	1	9.3 Feature Description.....	23
3 概要	1	9.4 Device Functional Modes.....	26
4 概要 (続き)	3	10 Application Information Disclaimer	29
5 Revision History	3	10.1 Application Information.....	29
6 Pin Configuration and Functions	4	10.2 Typical Application.....	29
7 Specifications	5	11 Layout	32
7.1 Absolute Maximum Ratings	5	11.1 Layout Guidelines.....	32
7.2 ESD Ratings	5	11.2 Layout Example.....	33
7.3 ESD Ratings - IEC	5	12 Device and Documentation Support	34
7.4 Thermal Information	6	12.1 Documentation Support.....	34
7.5 Recommended Operating Conditions	6	12.2 Receiving Notification of Documentation Updates..	34
7.6 Electrical Characteristics	7	12.3 サポート・リソース.....	34
7.7 Duty Cycle Characteristics	9	12.4 Trademarks.....	34
7.8 Switching Characteristics	11	12.5 Electrostatic Discharge Caution.....	35
7.9 Typical Characteristics.....	12	12.6 Glossary.....	35
8 Parameter Measurement Information	14	13 Mechanical, Packaging, and Orderable Information	35
9 Detailed Description	22		
9.1 Overview.....	22		

4 概要 (続き)

TLIN2022A-Q1 には LIN レスポンダ・ノード・アプリケーション用の抵抗、ESD 保護、フォルト保護が内蔵されているため、アプリケーションの外付け部品数を減らせます。このデバイスでは、グラウンドのシフトまたは電源電圧の切断が発生しても、電流が LIN 経由で電源入力に逆流することはありません。本デバイスは、低電圧検出、サーマル・シャットダウン保護、グラウンド喪失保護機能も内蔵しています。

5 Revision History

資料番号末尾の英字は改訂を表しています。その改訂履歴は英語版に準じています。

DATE	REVISION	NOTES
June 2021	*	Initial release

6 Pin Configuration and Functions



图 6-1. D Package, 14-Pin (SOIC), Top View



图 6-2. DMT Package, 14-Pin (VSON), Top View

表 6-1. Pin Functions

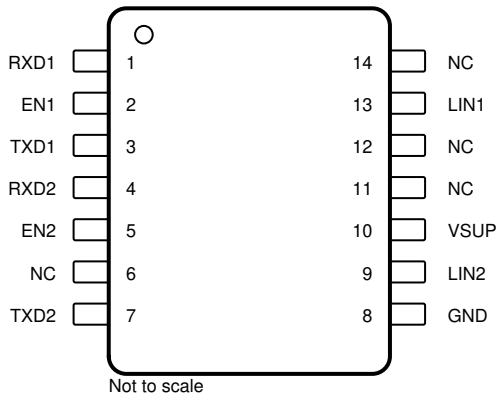
PIN		Type	DESCRIPTION
NO.	NAME		
1	RXD1	O	Channel 1 RXD Output (open-drain) interface reporting state of LIN bus voltage
2	EN1	I	Channel 1 Enable Input- High puts the channel 1 in normal operation mode and low puts it in sleep mode
3	TXD1	I	Channel 1 TXD input interface to control state of LIN output
4	RXD2	O	Channel 2 RXD Output (open-drain) interface reporting state of LIN bus voltage
5	EN2	I	Channel 2 Enable Input- High puts the channel 2 in normal operation mode and low puts it in sleep mode
7	TXD2	I	Channel 2 TXD input interface to control state of LIN output
8	GND	GND	Ground
9	LIN2	HV I/O	Channel 2 High voltage LIN bus single-wire transmitter and receiver
10	V _{SUP}	Supply	Device Supply Voltage (connected to battery in series with external reverse blocking diode)
13	LIN1	HV I/O	Channel 1 High voltage LIN bus single-wire transmitter and receiver
6, 11, 12, 14	NC	–	Not Connected
Thermal Pad		–	Can be connected to the PCB ground plane to improve thermal coupling (DMT package only)

7 Specifications

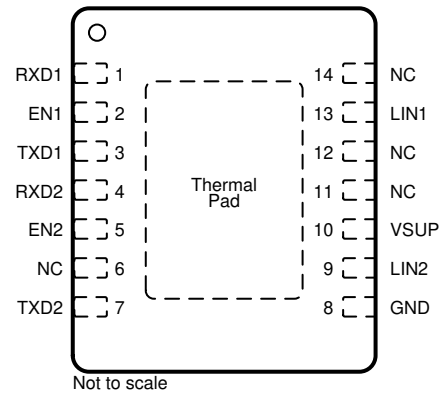
7.1 Absolute Maximum Ratings

(1) (2)

Symbol	Parameter	MIN	MAX	UNIT
V_{SUP}	Supply voltage range (ISO/DIS 17987 Param 10)	-0.3	60	V
V_{LIN}	LIN bus input voltage (ISO/DIS 17987 Param 82)	-60	60	V
V_{LOGIC}	Logic pin voltage (RXD, TXD, EN)	-0.3	6	V
I_O	Logic pin output current		8	mA
T_J	Junction temperature range	-55	150	°C

- (1) Stresses beyond those listed under Absolute Maximum Ratings may cause permanent damage to the device. These are stress ratings only, which do not imply functional operation of the device at these or any other conditions beyond those indicated under Recommended Operating Conditions. Exposure to absolute-maximum-rated conditions for extended periods may affect device reliability.
- (2) All voltage values are with respect to ground terminal.

7.2 ESD Ratings

ESD Ratings			VALUE	UNIT
$V_{(ESD)}$	Electrostatic discharge	Human body model (HBM) classification level 3A: TXD, RXD, EN Pins, per AEC Q100-002 ⁽¹⁾	±4000	V
		Human body model (HBM) classification level 3B: LIN and V_{SUP} Pin with respect to ground	±8000	
		Charged device model (CDM) classification level C5, per AEC Q100-011	All pins ±1500	

- (1) AEC Q100-002 indicates that HBM stressing shall be in accordance with the ANSI/ESDA/JEDEC JS-001 specification.

7.3 ESD Ratings - IEC

ESD and Surge Protection Ratings			VALUE	UNIT
$V_{(ESD)}$	Electrostatic discharge, LIN, V_{SUP} to GND ⁽¹⁾	IEC 62228-2 per ISO 10605 Contact discharge R = 330 Ω, C = 150 pF	±8000	V

7.3 ESD Ratings - IEC (continued)

ESD and Surge Protection Ratings		VALUE	UNIT	
V _{TRAN}	ISO 7637-2 and IEC 62228-2 per IEC 62215-3 transients according to IBEE LIN EMC test specifications ⁽²⁾ (LIN , V _{SUP} to GND)	IEC 62228-2 per IEC 62215-3 12 V electrical systems Pulse 1	-100	V
		IEC 62215-3 24 V electrical systems ⁽²⁾ Pulse 1	-450	
		IEC 62228-2 per IEC 62215-3 12 V electrical systems 24 V electrical systems ⁽²⁾ Pulse 2	75	
		IEC 62228-2 per IEC 62215-3 12 V electrical systems Pulse 3a	-150	
		IEC 62215-3 24 V electrical systems ⁽²⁾ Pulse 3a	-225	
		IEC 62228-2 per IEC 62215-3 12 V electrical systems Pulse 3b	100	
		IEC 62215-3 24 V electrical systems ⁽²⁾ Pulse 3b	225	

- (1) Results given here are specific to the IEC 62228-2 Integrated circuits – EMC evaluation of transceivers – Part 2: LIN transceivers. Testing performed by OEM approved independent 3rd party, EMC report available upon request.
- (2) Verified during characterization

7.4 Thermal Information

THERMAL METRIC ⁽¹⁾		TLIN2022AD-Q1	TLIN2022ADMT-Q1	UNIT
		D (SOIC)	DMT (VSON)	
		14-PINS	14-PINS	
R _{θJA}	Junction-to-ambient thermal resistance	82.3	35.5	°C/W
R _{θJC(top)}	Junction-to-case (top) thermal resistance	41.5	18.1	°C/W
R _{θJB}	Junction-to-board thermal resistance	38.4	13.1	°C/W
Ψ _{JT}	Junction-to-top characterization parameter	8.9	0.6	°C/W
Ψ _{JB}	Junction-to-board characterization parameter	38.1	13.1	°C/W
R _{θJC(bot)}	Junction-to-case (bottom) thermal resistance	n/a	2.5	°C/W

- (1) For more information about traditional and new thermal metrics, see the Semiconductor and IC Package Thermal Metrics application report, SPRA953.

7.5 Recommended Operating Conditions

parameters valid across -40°C ≤ T_A ≤ 125°C (unless otherwise noted)

PARAMETER - DEFINITION		MIN	NOM	MAX	UNIT
V _{SUP}	Supply voltage	4		48	V
V _{LIN}	LIN Bus input voltage	0		48	V
V _{LOGIC}	Logic Pin Voltage (RXD, TXD, EN)	0		5.25	V
T _A	Ambient temperature range	-40		125	°C
TSD	Thermal shutdown edge	165			°C
TSD _(HYS)	Thermal shutdown hysteresis		15		°C

7.6 Electrical Characteristics

parameters valid across $-40^{\circ}\text{C} \leq T_A \leq 125^{\circ}\text{C}$ (unless otherwise noted)

PARAMETER		TEST CONDITIONS	MIN	TYP	MAX	UNIT
Power Supply						
V_{SUP}	Operational supply voltage (ISO/DIS 17987 Param 10, 53)	Device is operational beyond the LIN defined nominal supply voltage range See Figure 8-1 and Figure 8-2	4		48	V
V_{SUP}	Nominal supply voltage (ISO/DIS 17987 Param 10, 53)	Normal and Standby Modes: ramp V_{SUP} while LIN signal is a 10 KHZ square wave with 50 % duty cycle and 36V swing. See Figure 8-1 and Figure 8-2	4		48	V
		Sleep Mode	4		48	V
UV_{SUP}	Undervoltage V_{SUP} threshold		2.9		3.85	V
UV_{HYS}	Delta hysteresis voltage for V_{SUP} undervoltage threshold			0.2		V
I_{SUP}	Supply current	Normal Mode: EN = High, bus dominant: total bus load where $R_{\text{LIN}} > 500 \Omega$ and $C_{\text{LIN}} < 10 \text{ nF}$		1.2	8.5	mA
		Standby Mode: EN = Low, bus dominant: total bus load where $R_{\text{LIN}} > 500 \Omega$ and $C_{\text{LIN}} < 10 \text{ nF}$		1.1	3.75	mA
I_{SUP}	Supply current	Normal Mode: EN = High, Bus Recessive: LIN = V_{SUP}		670	1600	μA
		Standby Mode: EN = Low, Bus Recessive LIN = V_{SUP}		20	40	μA
		Sleep Mode: $4.0 \text{ V} < V_{\text{SUP}} < 14 \text{ V}$, LIN = V_{SUP} , EN = 0 V, TXD and RXD Floating		10	20	μA
		Sleep Mode: $14 \text{ V} < V_{\text{SUP}} < 36 \text{ V}$, LIN = V_{SUP} , EN = 0 V, TXD and RXD floating			30	μA
RXD1/RXD2 OUTPUT PIN (OPEN DRAIN)						
V_{OL}	Output Low voltage	Based upon external pull-up to V_{CC} ⁽⁴⁾			0.6	V
I_{OL}	Low-level output current, open-drain	LIN = 0 V, RXD = 0.4 V	1.5			mA
I_{ILG}	Leakage current, high-level	LIN = V_{SUP} , RXD = 5 V	-5	0	5	μA
TXD1/TXD2 INPUT PIN						
V_{IL}	Low-level input voltage		-0.3		0.8	V
V_{IH}	High-level input voltage		2		5.25	V
V_{HYS}	Input threshold voltage, normal modes & selective wake modes			50	500	mV
I_{ILG}	Low-level input leakage current	TXD = Low	-5	0	5	μA
R_{TXD}	Internal pull-down resistor value		125	350	800	k Ω
EN1/EN2 INPUT PIN						
V_{IL}	Low-level input voltage		-0.3		0.8	V
V_{IH}	High-level input voltage		2		5.25	V
V_{HYS}	Hysteresis voltage	By design and characterization		50	500	mV
I_{ILG}	Low-level input current	EN = Low	-5	0	5	μA
R_{EN}	Internal pull-down resistor		125	350	800	k Ω
LIN1/LIN2 PIN						
V_{OH}	HIGH level output voltage ⁽³⁾	LIN recessive, TXD = high, $I_{\text{O}} = 0 \text{ mA}$, $7 \text{ V} \leq V_{\text{SUP}} \leq 48 \text{ V}$	0.85			V_{SUP}
V_{OH}	LIN recessive high-level output voltage ^{(1) (2)}	TXD = high, $I_{\text{O}} = 0 \text{ mA}$, $7 \text{ V} \leq V_{\text{SUP}} \leq 18 \text{ V}$	0.8			V_{SUP}
V_{OH}	HIGH level output voltage ⁽³⁾	LIN recessive, TXD = high, $I_{\text{O}} = 0 \text{ mA}$, $4 \text{ V} \leq V_{\text{SUP}} < 7 \text{ V}$	3			V

7.6 Electrical Characteristics (continued)

parameters valid across $-40^{\circ}\text{C} \leq T_A \leq 125^{\circ}\text{C}$ (unless otherwise noted)

PARAMETER		TEST CONDITIONS	MIN	TYP	MAX	UNIT
V_{OL}	LOW level output voltage ⁽³⁾	LIN dominant, TXD = low, $7\text{ V} \leq V_{SUP} \leq 48\text{ V}$			0.2	V_{SUP}
V_{OL}	LIN dominant low- level output voltage ^{(1) (2)}	TXD = low, $7\text{ V} \leq V_{SUP} \leq 18\text{ V}$			0.2	V_{SUP}
V_{OL}	LOW level output voltage ⁽³⁾	LIN dominant, TXD = low, $4\text{ V} \leq V_{SUP} < 7\text{ V}$			1.2	V
$V_{SUP_NON_OP}$	V_{SUP} where impact of recessive LIN bus < 5% (ISO/DIS 17987 Param 56)	TXD & RXD open LIN = 4 V to 58 V	-0.3		58	V
I_{BUS_LIM}	Limiting current (ISO/DIS 17987 Param 57)	TXD = 0 V, $V_{LIN} = 48\text{ V}$, $R_{MEAS} = 440\ \Omega$, $V_{SUP} = 48\text{ V}$, $V_{BUSdom} < 4.518\text{ V}$	75	120	300	mA
$I_{BUS_PAS_dom}$	Receiver leakage current, dominant (ISO/DIS 17987 Param 58)	LIN = 0 V, $V_{SUP} = 24\text{ V}$ Driver off/ recessive; See Figure 8-6	-2			mA
$I_{BUS_PAS_rec1}$	Receiver leakage current, recessive (ISO/DIS 17987 Param 59)	LIN > V_{SUP} , $8\text{ V} \leq V_{SUP} \leq 48\text{ V}$ Driver off; See Figure 8-7			20	μA
$I_{BUS_PAS_rec2}$	Receiver leakage current, recessive (ISO/DIS 17987 Param 59)	LIN = V_{SUP} , Driver off; See Figure 8-7	-5		5	μA
$I_{BUS_NO_GND}$	Leakage current, loss of ground (ISO/DIS 17987 Param 60)	GND = V_{SUP} , $0\text{ V} \leq V_{LIN} = 36\text{ V}$, $V_{SUP} = 24\text{ V}$; See Figure 8-8	-2		2	mA
$I_{leak\ gnd(dom)}$	Leakage current, loss of ground ⁽⁵⁾	$V_{SUP} = 8\text{ V}$, GND = open, $V_{SUP} = 18\text{ V}$, GND = open $R_{Commander} = 1\text{ k}\Omega$, $C_L = 1\text{ nF}$ $R_{Responder} = 20\text{ k}\Omega$, $C_L = 1\text{ nF}$ LIN = dominant	-1		1	mA
$I_{leak\ gnd(rec)}$	Leakage current, loss of ground ⁽⁵⁾	$V_{SUP} = 8\text{ V}$, GND = open, $V_{SUP} = 18\text{ V}$, GND = open $R_{Commander} = 1\text{ k}\Omega$, $C_L = 1\text{ nF}$ $R_{Responder} = 20\text{ k}\Omega$, $C_L = 1\text{ nF}$ LIN = recessive	-100		100	μA
$I_{BUS_NO_BAT}$	Leakage current, loss of supply (ISO/DIS 17987 Param 61)	$0\text{ V} \leq V_{LIN} \leq 48\text{ V}$, $V_{SUP} = \text{GND}$; See Figure 8-9			5	μA
V_{BUSdom}	Low-level input voltage (ISO/DIS 17987 Param , 62)	LIN dominant (including LIN dominant for wake up); See Figure 8-3 and Figure 8-4			0.4	V_{SUP}
V_{BUSrec}	High-level input voltage (ISO/DIS 17987 Param , 63)	LIN recessive; See Figure 8-3 and Figure 8-4	0.6			V_{SUP}
V_{IH}	LIN recessive high-level input voltage ^{(1) (2)}	$7\text{ V} \leq V_{SUP} \leq 18\text{ V}$	0.47		0.6	V_{SUP}
V_{IL}	LIN dominant low-level input voltage ^{(1) (2)}	$7\text{ V} \leq V_{SUP} \leq 18\text{ V}$	0.4		0.53	V_{SUP}
V_{BUS_CNT}	Receiver center threshold (ISO/DIS 17987 Param , 64)	$V_{BUS_CNT} = (V_{BUSdom} + V_{BUSrec})/2$; See Figure 8-3 and Figure 8-4	0.475	0.5	0.525	V_{SUP}
V_{HYS}	Hysteresis voltage (ISO/DIS 17987 Param , 65)	$V_{HYS} = (V_{BUSrec} - V_{BUSdom})$; See Figure 8-3 and Figure 8-4			0.175	V_{SUP}
V_{HYS}	Hysteresis voltage (SAE J2602)	$V_{HYS} = V_{IH} - V_{IL}$; See Figure 8-3 and Figure 8-4	0.07		0.175	V_{SUP}
V_{SERIAL_DIODE}	Serial diode LIN termination pullup path (ISO/DIS 17987 Param , 66)	$I_{SERIAL_DIODE} = 10\ \mu\text{A}$	0.4	0.7	1	V
R_{PU}	Pull-up resistor to V_{SUP} (ISO/DIS 17987 Param , 71)	Normal and Standby modes	20	45	60	k Ω
I_{RSLEEP}	Pull-up current source to V_{SUP}	Sleep mode, $V_{SUP} = 27\text{ V}$, LIN = GND	-20		-2	μA
C_{LINPIN}	Capacitance of the LIN pin	$V_{SUP} = 14\text{ V}$			25	pF

(1) SAE 2602 commander node load conditions: 5.5 nF/4 k Ω and 899 pF/20 k Ω

(2) SAE 2602 responder node load conditions: 5.5 nF/875 Ω and 899 pF/900 Ω

- (3) ISO 17987 bus load conditions (C_{LINBUS} , R_{LINBUS}) include 1 nF/1 k Ω ; 6.8 nF/660 Ω ; 10 nF/500 Ω .
- (4) RXD uses open drain output structure therefore V_{OL} level is based upon microcontroller supply voltage V_{CC} .
- (5) $I_{leak\ gnd} = (V_{BAT} - V_{LIN})/R_{Load}$

7.7 Duty Cycle Characteristics

parameters valid across $-40^{\circ}\text{C} \leq T_A \leq 125^{\circ}\text{C}$ (unless otherwise noted)

PARAMETER		TEST CONDITIONS	MIN	TYP	MAX	UNIT
D1 _{12V}	Duty Cycle 1 (ISO/DIS 17987 Param 27) ⁽³⁾	$TH_{REC(MAX)} = 0.744 \times V_{SUP}$, $TH_{DOM(MAX)} = 0.581 \times V_{SUP}$, $V_{SUP} = 7\text{ V to }18\text{ V}$, $t_{BIT} = 50\ \mu\text{s}$ (20 kbps), $D1 = t_{BUS_rec(min)}/(2 \times t_{BIT})$ (See Figure 8-10, Figure 8-11)	0.396			
D1 _{12V}	Duty Cycle 1 (ISO/DIS 17987 Param 27) ^{(3) (4)}	$TH_{REC(MAX)} = 0.625 \times V_{SUP}$, $TH_{DOM(MAX)} = 0.581 \times V_{SUP}$, $V_{SUP} = 4\text{ V to }7\text{ V}$, $t_{BIT} = 50\ \mu\text{s}$ (20 kbps), $D1 = t_{BUS_rec(min)}/(2 \times t_{BIT})$ (See Figure 8-10, Figure 8-11)	0.396			
D1	Duty cycle 1 ^{(1) (2) (4)}	$TH_{REC(MAX)} = 0.744 \times V_{SUP}$, $TH_{DOM(MAX)} = 0.581 \times V_{SUP}$, $V_{SUP} = 7\text{ V to }18\text{ V}$, $t_{BIT} = 52\ \mu\text{s}$, $D1 = t_{BUS_rec(min)}/(2 \times t_{BIT})$ (See Figure 8-10, Figure 8-11)	0.396			
D2 _{12V}	Duty Cycle 2 (ISO/DIS 17987 Param 28) ⁽³⁾	$TH_{REC(MIN)} = 0.422 \times V_{SUP}$, $TH_{DOM(MIN)} = 0.284 \times V_{SUP}$, $V_{SUP} = 7\text{ V to }18\text{ V}$, $t_{BIT} = 50\ \mu\text{s}$ (20 kbps), $D2 = t_{BUS_rec(MAX)}/(2 \times t_{BIT})$ (See Figure 8-10, Figure 8-11)			0.581	
D2 _{12V}	Duty Cycle 2 ^{(3) (4)}	$TH_{REC(MIN)} = 0.546 \times V_{SUP}$, $TH_{DOM(MIN)} = 0.4 \times V_{SUP}$, $V_{SUP} = 4\text{ V to }7\text{ V}$, $t_{BIT} = 50\ \mu\text{s}$ (20 kbps), $D2 = t_{BUS_rec(MAX)}/(2 \times t_{BIT})$ (See Figure 8-10, Figure 8-11)			0.581	
D2	Duty Cycle 2 ^{(1) (2) (4)}	$TH_{REC(MIN)} = 0.422 \times V_{SUP}$, $TH_{DOM(MIN)} = 0.284 \times V_{SUP}$, $V_{SUP} = 7\text{ V to }18\text{ V}$, $t_{BIT} = 52\ \mu\text{s}$, $D2 = t_{BUS_rec(MAX)}/(2 \times t_{BIT})$ (See Figure 8-10, Figure 8-11)			0.581	
D3 _{12V}	Duty Cycle 3 (ISO/DIS 17987 Param 29) ⁽³⁾	$TH_{REC(MAX)} = 0.778 \times V_{SUP}$, $TH_{DOM(MAX)} = 0.616 \times V_{SUP}$, $V_{SUP} = 7\text{ V to }18\text{ V}$, $t_{BIT} = 96\ \mu\text{s}$ (10.4 kbps), $D3 = t_{BUS_rec(min)}/(2 \times t_{BIT})$ (See Figure 8-10, Figure 8-11)	0.417			
D3 _{12V}	Duty Cycle 3 ^{(3) (4)}	$TH_{REC(MAX)} = 0.645 \times V_{SUP}$, $TH_{DOM(MAX)} = 0.616 \times V_{SUP}$, $V_{SUP} = 4\text{ V to }7\text{ V}$, $t_{BIT} = 96\ \mu\text{s}$ (10.4 kbps), $D3 = t_{BUS_rec(min)}/(2 \times t_{BIT})$ (See Figure 8-10, Figure 8-11)	0.417			
D3	Duty Cycle 3 ^{(1) (2) (4)}	$TH_{REC(MAX)} = 0.778 \times V_{SUP}$, $TH_{DOM(MAX)} = 0.616 \times V_{SUP}$, $V_{SUP} = 7\text{ V to }18\text{ V}$, $t_{BIT} = 96\ \mu\text{s}$, $D3 = t_{BUS_rec(min)}/(2 \times t_{BIT})$ (See Figure 8-10, Figure 8-11)	0.417			
D4 _{12V}	Duty Cycle 4 (ISO/DIS 17987 Param 30) ⁽³⁾	$TH_{REC(MIN)} = 0.389 \times V_{SUP}$, $TH_{DOM(MIN)} = 0.251 \times V_{SUP}$, $V_{SUP} = 7\text{ V to }18\text{ V}$, $t_{BIT} = 96\ \mu\text{s}$ (10.4 kbps), $D4 = t_{BUS_rec(MAX)}/(2 \times t_{BIT})$ (See Figure 8-10, Figure 8-11)			0.59	
D4 _{12V}	Duty Cycle 4 ^{(3) (4)}	$TH_{REC(MIN)} = 0.422 \times V_{SUP}$, $TH_{DOM(MIN)} = 0.284 \times V_{SUP}$, $V_{SUP} = 4\text{ V to }7\text{ V}$, $t_{BIT} = 96\ \mu\text{s}$ (10.4 kbps), $D4 = t_{BUS_rec(MAX)}/(2 \times t_{BIT})$ (See Figure 8-10, Figure 8-11)			0.59	
D4	Duty Cycle 4 ^{(1) (2) (4)}	$TH_{REC(MIN)} = 0.389 \times V_{SUP}$, $TH_{DOM(MIN)} = 0.251 \times V_{SUP}$, $V_{SUP} = 7\text{ V to }18\text{ V}$, $t_{BIT} = 96\ \mu\text{s}$, $D4 = t_{BUS_rec(MAX)}/(2 \times t_{BIT})$ (See Figure 8-10, Figure 8-11)			0.59	

7.7 Duty Cycle Characteristics (continued)

 parameters valid across $-40^{\circ}\text{C} \leq T_A \leq 125^{\circ}\text{C}$ (unless otherwise noted)

PARAMETER		TEST CONDITIONS	MIN	TYP	MAX	UNIT
D1 _{24V}	Duty Cycle 1 (ISO/DIS 17987 Param 27) ⁽¹⁾	$T_{H_{REC}(MAX)} = 0.710 \times V_{SUP}$, $T_{H_{DOM}(MAX)} = 0.544 \times V_{SUP}$, $V_{SUP} = 15\text{ V to }36\text{ V}$, $t_{BIT} = 50\ \mu\text{s}$ (20 kbps), $D1 = t_{BUS_rec(min)}/(2 \times t_{BIT})$ (See Figure 8-10, Figure 8-11)	0.33			
D2 _{24V}	Duty Cycle 2 (ISO/DIS 17987 Param 28)	$T_{H_{REC}(MIN)} = 0.446 \times V_{SUP}$, $T_{H_{DOM}(MIN)} = 0.302 \times V_{SUP}$, $V_{SUP} = 15.6\text{ V to }36\text{ V}$, $t_{BIT} = 50\ \mu\text{s}$ (20 kbps), $D2 = t_{BUS_rec(MAX)}/(2 \times t_{BIT})$ (See Figure 8-10, Figure 8-11)			0.642	
D3 _{24V}	Duty Cycle 3 (ISO/DIS 17987 Param 29)	$T_{H_{REC}(MAX)} = 0.744 \times V_{SUP}$, $T_{H_{DOM}(MAX)} = 0.581 \times V_{SUP}$, $V_{SUP} = 7\text{ V to }36\text{ V}$, $t_{BIT} = 96\ \mu\text{s}$ (10.4 kbps), $D3 = t_{BUS_rec(min)}/(2 \times t_{BIT})$ (See Figure 8-10, Figure 8-11)	0.386			
D4 _{24V}	Duty Cycle 4 (ISO/DIS 17987 Param 30) ⁽⁴⁾	$T_{H_{REC}(MIN)} = 0.422 \times V_{SUP}$, $T_{H_{DOM}(MIN)} = 0.284 \times V_{SUP}$, $V_{SUP} = 7.6\text{ V to }36\text{ V}$, $t_{BIT} = 96\ \mu\text{s}$ (10.4 kbps), $D4 = t_{BUS_rec(MAX)}/(2 \times t_{BIT})$ (See Figure 8-10, Figure 8-11)			0.591	
D1 _{LB}	Duty cycle 1 at low battery ^{(1) (2) (4)}	$T_{H_{REC}(MAX)} = 0.665 \times V_{SUP}$, $T_{H_{DOM}(MAX)} = 0.499 \times V_{SUP}$, $V_{SUP} = 5.5\text{ V to }7\text{ V}$, $t_{BIT} = 52\ \mu\text{s}$	0.396			
D2 _{LB}	Duty cycle 2 at low battery ^{(1) (2) (4)}	$T_{H_{REC}(MAX)} = 0.496 \times V_{SUP}$, $T_{H_{DOM}(MAX)} = 0.361 \times V_{SUP}$, $V_{SUP} = 6.1\text{ V to }7\text{ V}$, $t_{BIT} = 52\ \mu\text{s}$			0.581	
D3 _{LB}	Duty cycle 3 at low battery ^{(1) (2) (4)}	$T_{H_{REC}(MAX)} = 0.665 \times V_{SUP}$, $T_{H_{DOM}(MAX)} = 0.499 \times V_{SUP}$, $V_{SUP} = 5.5\text{ V to }7\text{ V}$, $t_{BIT} = 96\ \mu\text{s}$	0.396			
D4 _{LB}	Duty cycle 4 at low battery ^{(1) (2) (4)}	$T_{H_{REC}(MAX)} = 0.496 \times V_{SUP}$, $T_{H_{DOM}(MAX)} = 0.361 \times V_{SUP}$, $V_{SUP} = 6.1\text{ V to }7\text{ V}$, $t_{BIT} = 96\ \mu\text{s}$			0.581	
Tr-d max	Transmitter propagation delay timings for the duty cycle ^{(1) (2) (4)} Recessive to dominant	$T_{H_{REC}(MAX)} = 0.744 \times V_{SUP}$, $T_{H_{DOM}(MAX)} = 0.581 \times V_{SUP}$, $7\text{ V} \leq V_{SUP} \leq 18\text{ V}$, $t_{BIT} = 52\ \mu\text{s}$ $t_{REC(MAX)}_{D1} - t_{DOM(MIN)}_{D1}$			10.8	μs
Td-r max	Transmitter propagation delay timings for the duty cycle ^{(1) (2) (4)} Dominant to recessive	$T_{H_{REC}(MAX)} = 0.422 \times V_{SUP}$, $T_{H_{DOM}(MAX)} = 0.284 \times V_{SUP}$, $7\text{ V} \leq V_{SUP} \leq 18\text{ V}$, $t_{BIT} = 52\ \mu\text{s}$ $t_{DOM(MAX)}_{D2} - t_{REC(MIN)}_{D2}$			8.4	μs
Tr-d max	Transmitter propagation delay timings for the duty cycle ^{(1) (2) (4)} Recessive to dominant	$T_{H_{REC}(MAX)} = 0.778 \times V_{SUP}$, $T_{H_{DOM}(MAX)} = 0.616 \times V_{SUP}$, $7\text{ V} \leq V_{SUP} \leq 18\text{ V}$, $t_{BIT} = 96\ \mu\text{s}$ $t_{REC(MAX)}_{D3} - t_{DOM(MIN)}_{D3}$			15.9	μs
Td-r max	Transmitter propagation delay timings for the duty cycle ^{(1) (2) (4)} Dominant to recessive	$T_{H_{REC}(MIN)} = 0.389 \times V_{SUP}$, $T_{H_{DOM}(MIN)} = 0.251 \times V_{SUP}$, $7\text{ V} \leq V_{SUP} \leq 18\text{ V}$, $t_{BIT} = 96\ \mu\text{s}$ $t_{DOM(MAX)}_{D4} - t_{REC(MIN)}_{D4}$			17.28	μs
Tr-d max_low	Low battery transmitter propagation delay timings for the duty cycle ^{(1) (2) (4)} Recessive to dominant	$T_{H_{REC}(MAX)} = 0.665 \times V_{SUP}$, $T_{H_{DOM}(MAX)} = 0.499 \times V_{SUP}$, $5.5\text{ V} \leq V_{SUP} \leq 7\text{ V}$, $t_{BIT} = 52\ \mu\text{s}$ $t_{REC(MAX)}_{low} - t_{DOM(MIN)}_{low}$			10.8	μs
Td-r max_low	Low battery transmitter propagation delay timings for the duty cycle ^{(1) (2) (4)} Dominant to recessive	$T_{H_{REC}(MAX)} = 0.496 \times V_{SUP}$, $T_{H_{DOM}(MAX)} = 0.361 \times V_{SUP}$, $6.1\text{ V} \leq V_{SUP} \leq 7\text{ V}$, $t_{BIT} = 52\ \mu\text{s}$ $t_{DOM(MAX)}_{low} - t_{REC(MIN)}_{low}$			8.4	μs

 (1) SAE 2602 commander node load conditions: 5.5 nF/4 k Ω and 899 pF/20 k Ω

 (2) SAE 2602 responder node load conditions: 5.5 nF/875 Ω and 899 pF/900 Ω

- (3) ISO 17987 bus load conditions (C_{LINBUS} , R_{LINBUS}) include 1 nF/1 k Ω ; 6.8 nF/660 Ω ; 10 nF/500 Ω .
 (4) Specified by design

7.8 Switching Characteristics

parameters valid across $-40^{\circ}\text{C} \leq T_A \leq 125^{\circ}\text{C}$ (unless otherwise noted)

SYMBOL	DESCRIPTION	TEST CONDITIONS	MIN	NOM	MAX	UNIT
t_{rx_pdr}	Receiver rising propagation delay time (ISO/DIS 17987 Param 31)	$R_{RXD} = 2.4 \text{ k}\Omega$, $C_{RXD} = 20 \text{ pF}$ (See Figure 8-12 and Figure 8-13)			6	μs
t_{rx_pdf}	Receiver falling propagation delay time (ISO/DIS 17987 Param 31)				6	μs
t_{rs_sym}	Symmetry of receiver propagation delay time	Rising edge with respect to falling edge, ($trx_sym = trx_pdf - trx_pdr$), $R_{RXD} = 2.4 \text{ k}\Omega$, $C_{RXD} = 20 \text{ pF}$ (See Figure 8-12 and Figure 8-13)	-2		2	μs
t_{LINBUS}	LIN wakeup time (Minimum dominant time on LIN bus for wakeup)	See Figure 8-16 , Figure 9-2 and Figure 9-3	25	100	150	μs
t_{CLEAR}	Time to clear false wakeup prevention logic if LIN bus had a bus stuck dominant fault (recessive time on LIN bus to clear bus stuck dominant fault)	See Figure 9-3	8	17	50	μs
t_{DST}	Dominant state time out		20	34	80	ms
t_{MODE_CHANGE}	Mode change delay time	Time to change from standby mode to normal mode or normal mode to sleep mode through EN pin; See Figure 8-14 and Figure 9-4	2		15	μs
t_{NOMINT}	Normal mode initialization time	Time for normal mode to initialize and data on RXD pin to be valid; See Figure 8-14			35	μs
t_{PWR}	Power up time	Upon power up time it takes for valid data on RXD			1.5	ms

7.9 Typical Characteristics

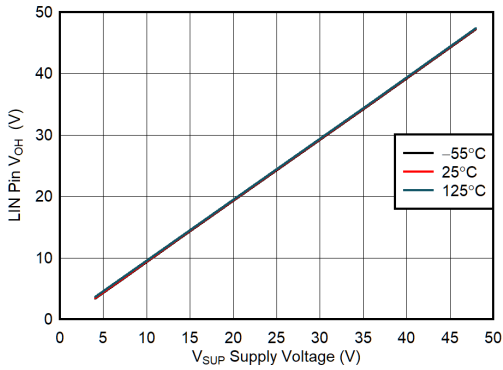

7-1. V_{OH} vs V_{SUP} and Temperature

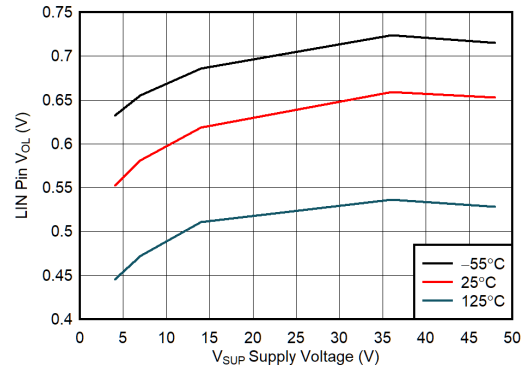

7-2. V_{OL} vs V_{SUP} and Temperature

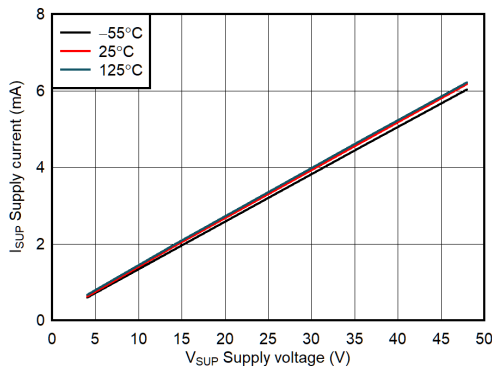

Normal Mode (Dominant)

7-3. Supply Current vs Voltage Supply Across Temperature

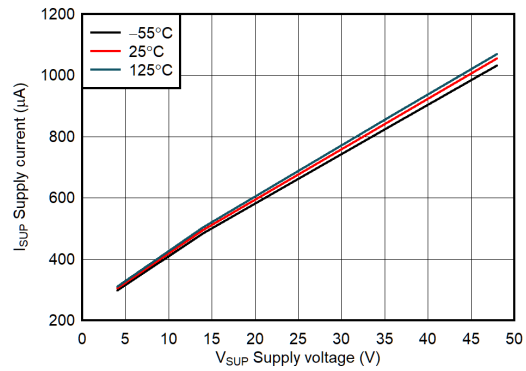

Normal Mode (Recessive)

7-4. Supply Current vs Voltage Supply Across Temperature

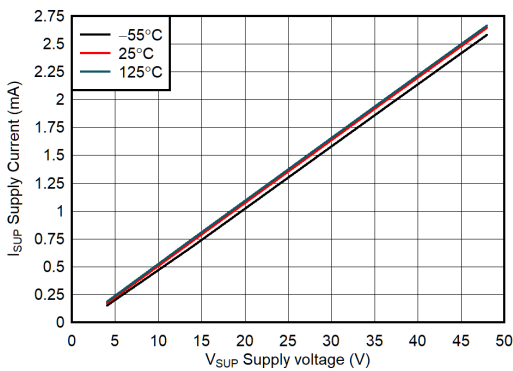

Standby Mode (Dominant)

7-5. Supply Current vs Voltage Supply and Temperature

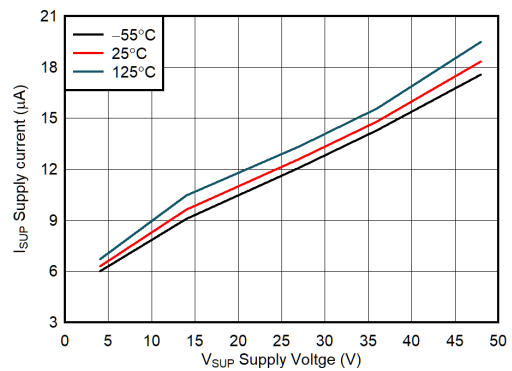

Standby Mode (Recessive)

7-6. Supply Current vs Voltage Supply and Temperature

7.9 Typical Characteristics (continued)

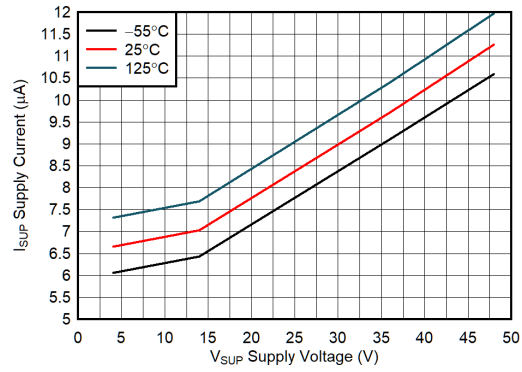

Sleep Mode

 **7-7. Supply Current vs Voltage Supply and Temperature**

8 Parameter Measurement Information

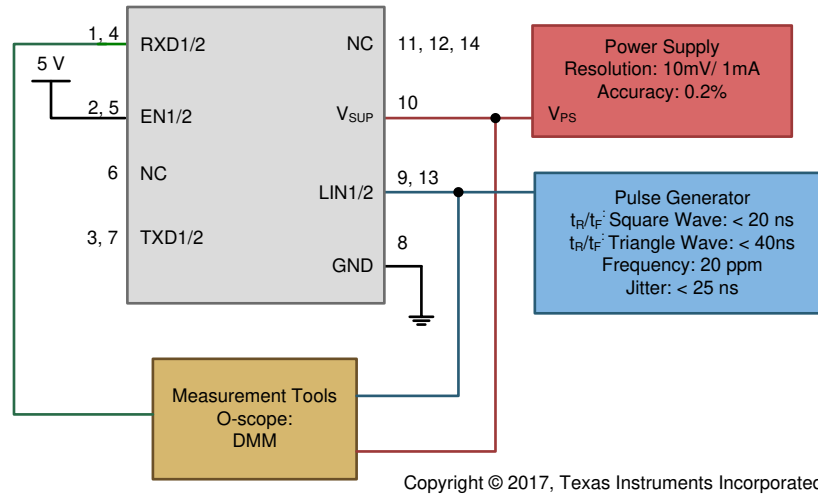

8-1. Test System: Operating Voltage Range with RX and TX Access: Parameters 9, 10

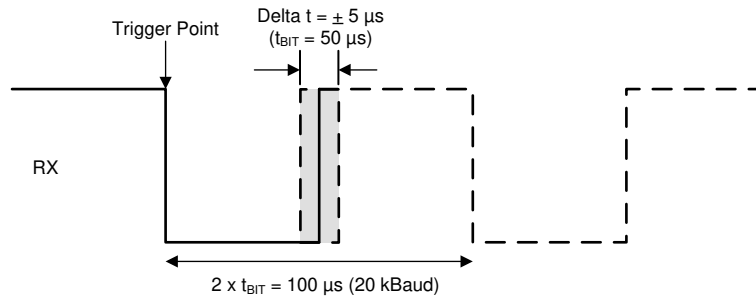

8-2. RX Response: Operating Voltage Range

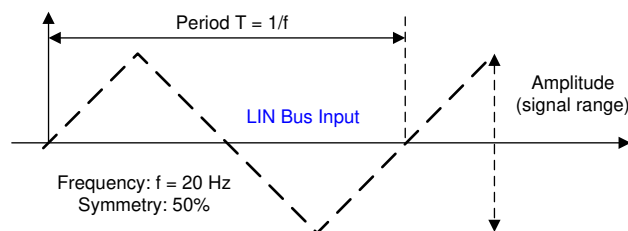

8-3. LIN Bus Input Signal

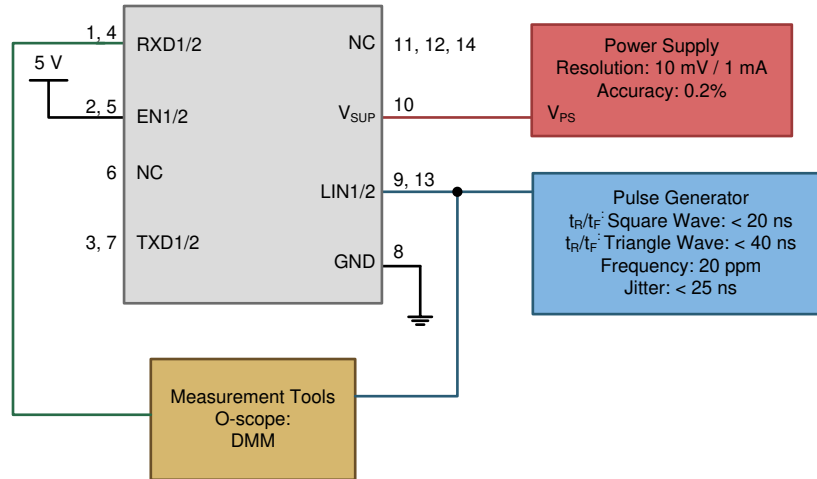

Copyright © 2017, Texas Instruments Incorporated

8-4. LIN Receiver Test with RX access Parameters 17, 18, 19, 20

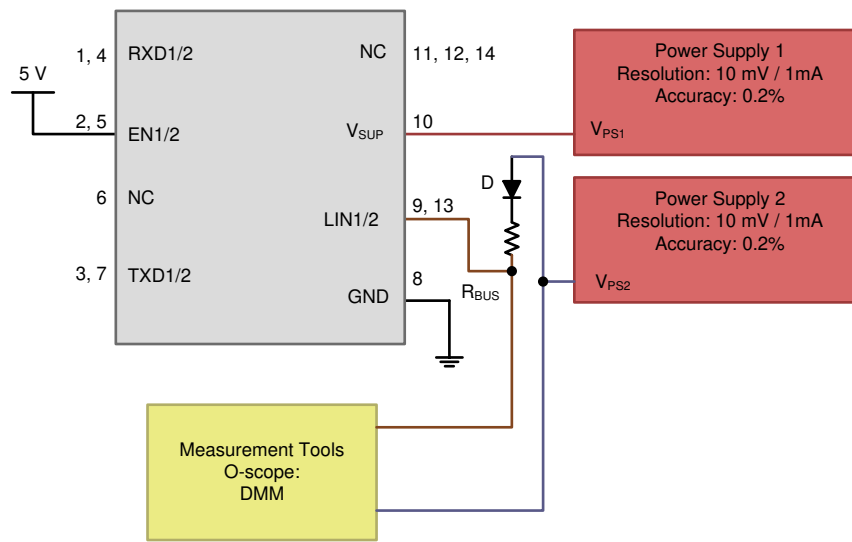

Copyright © 2017, Texas Instruments Incorporated

8-5. $V_{SUP_NON_OP}$ Parameters 11

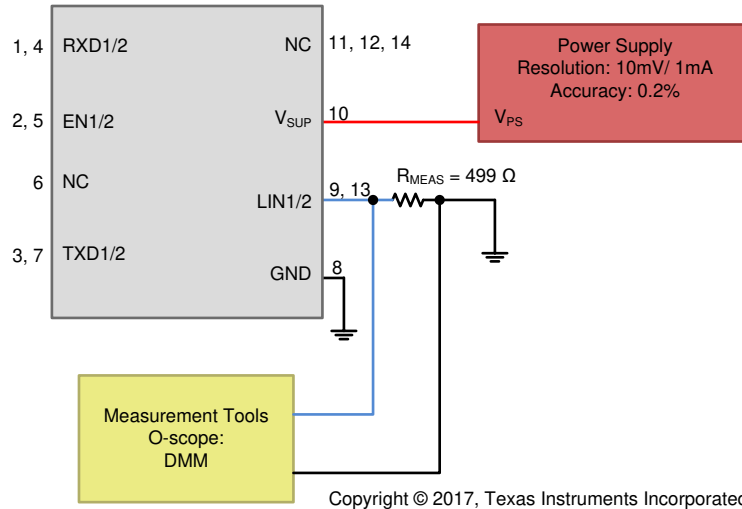

8-6. Test Circuit for $I_{BUS_PAS_dom}$; TXD = Recessive State $V_{BUS} = 0$ V, Parameters 13

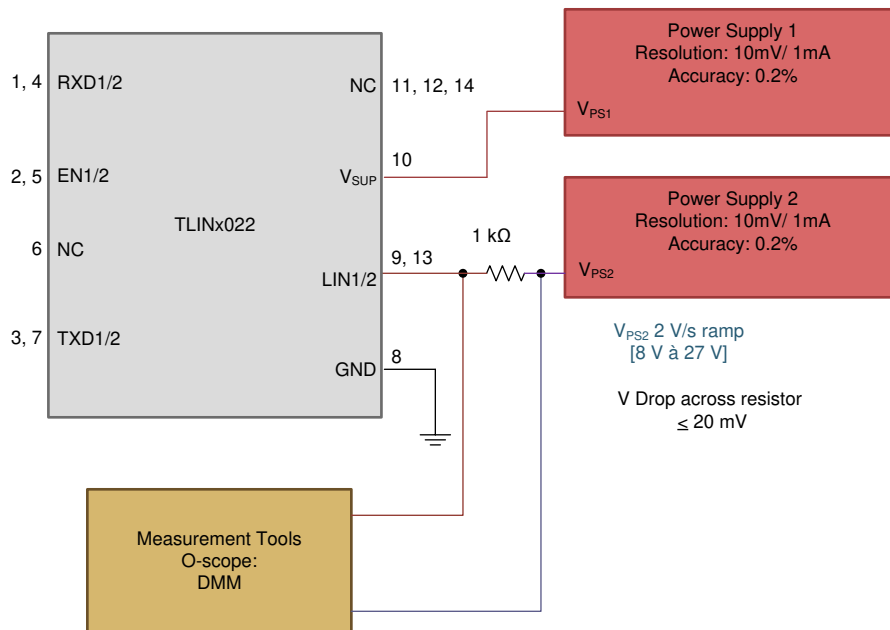

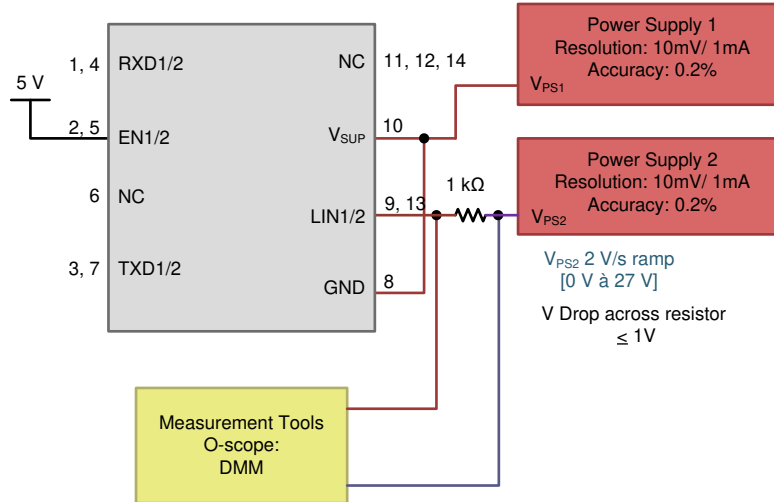

Copyright © 2017, Texas Instruments Incorporated

8-8. Test Circuit for $I_{BUS_NO_GND}$ Loss of GND

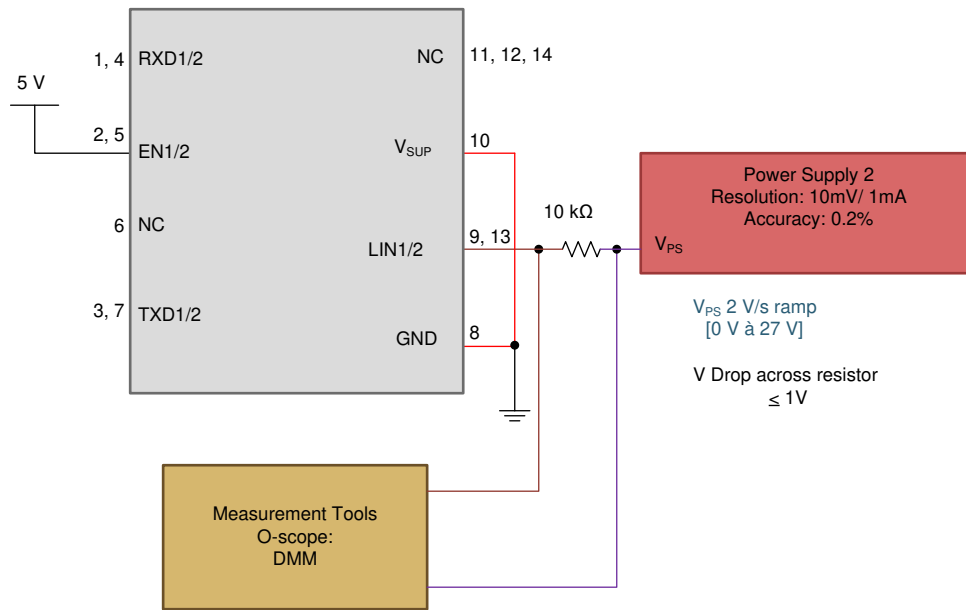

Copyright © 2017, Texas Instruments Incorporated

8-9. Test Circuit for $I_{BUS_NO_BAT}$ Loss of Battery

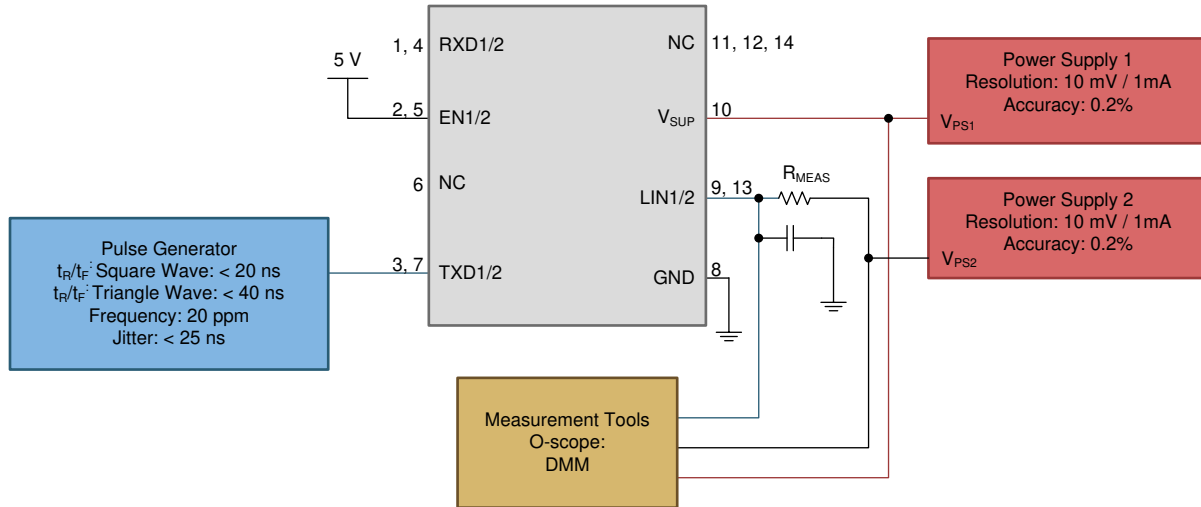

Copyright © 2017, Texas Instruments Incorporated

8-10. Test Circuit Slope Control and Duty Cycle Parameters 27, 28, 29, 30

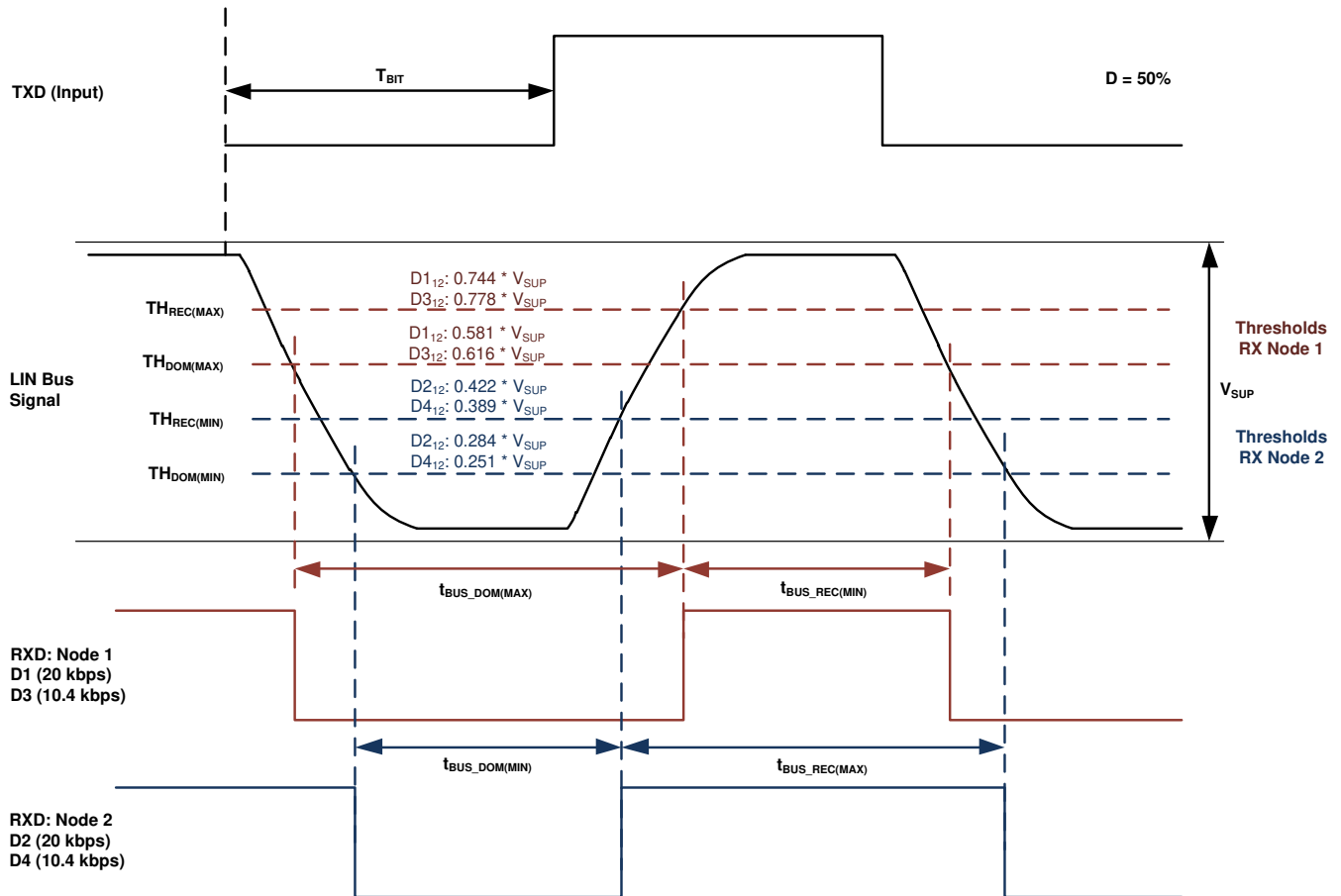

8-11. Definition of Bus Timing Parameters

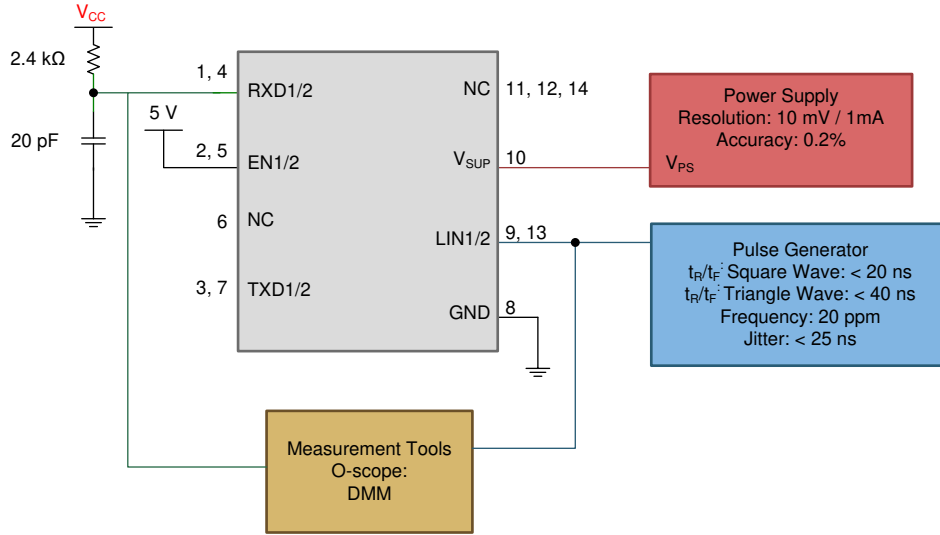

Copyright © 2017, Texas Instruments Incorporated

8-12. Propagation Delay Test Circuit; Parameters 31, 32

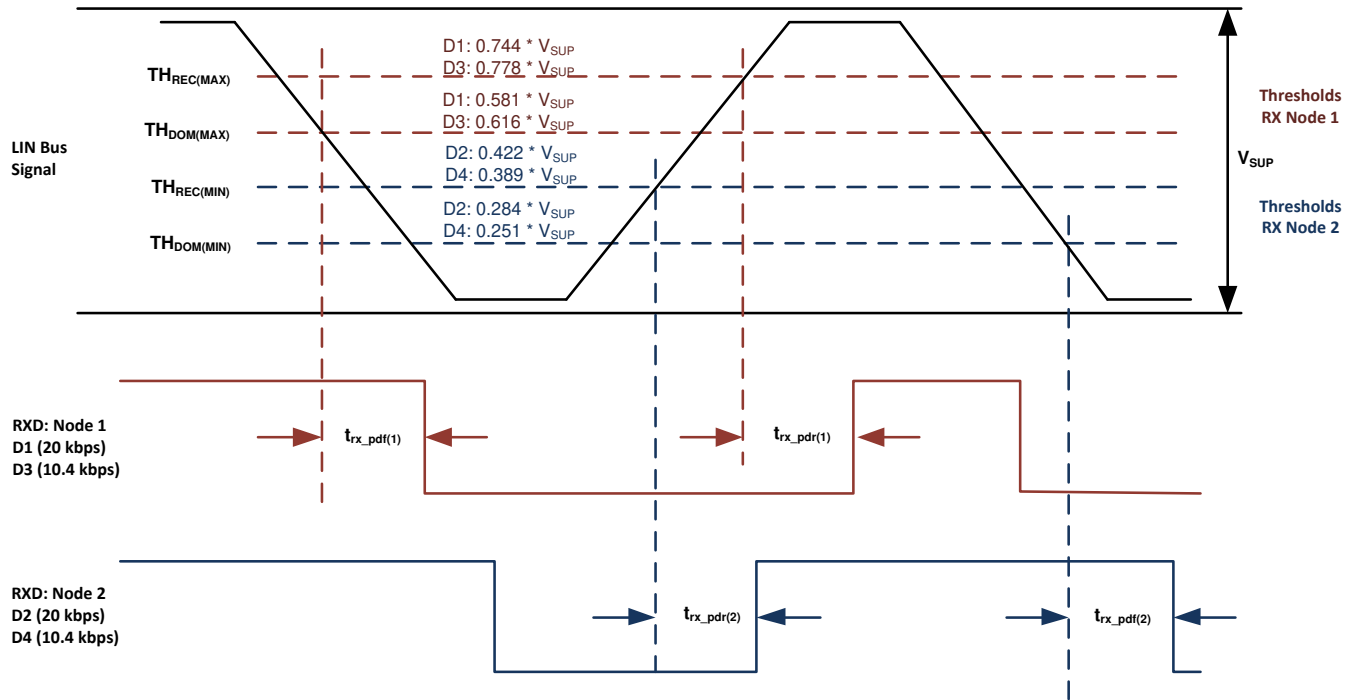

8-13. Propagation Delay

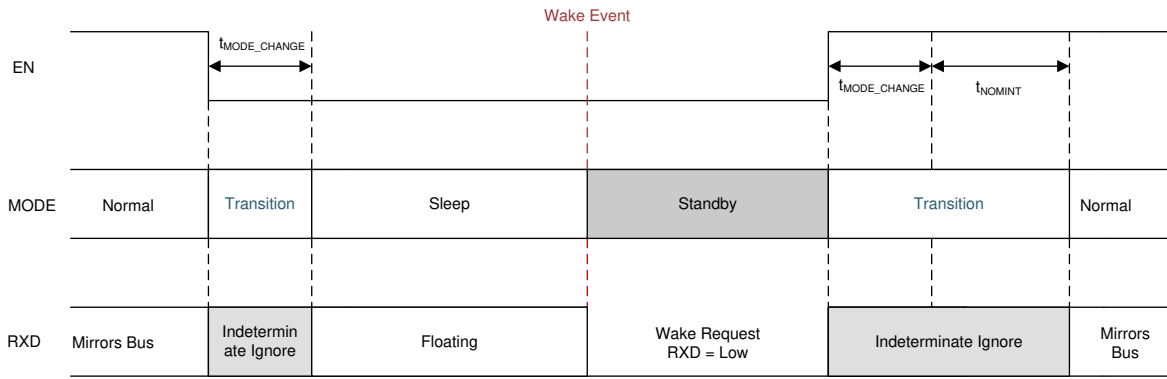

Copyright © 2017, Texas Instruments Incorporated

8-14. Mode Transitions

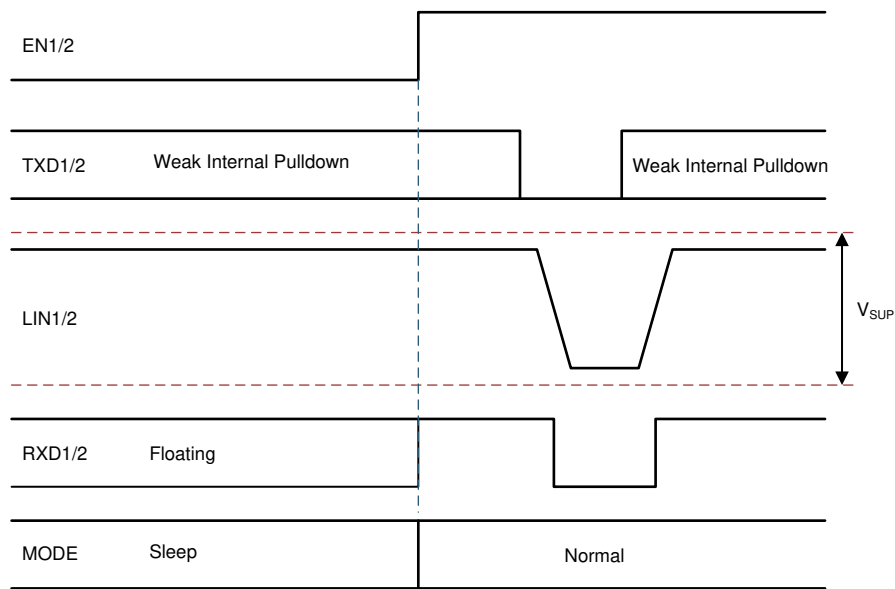

8-15. Wakeup Through EN

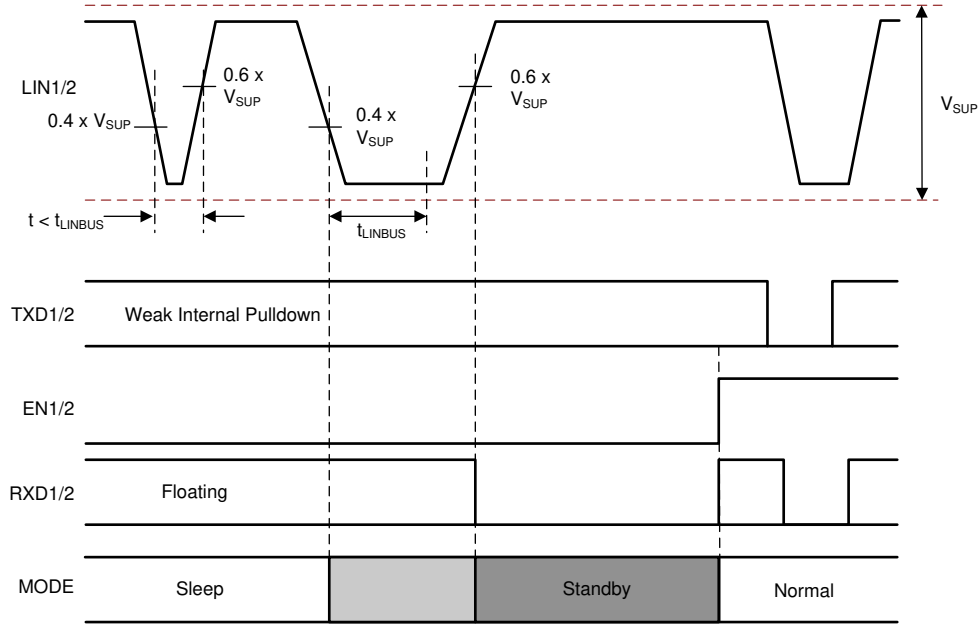

8-16. Wakeup through LIN

9 Detailed Description

9.1 Overview

The TLIN2022A-Q1 device is a Dual Local Interconnect Network (LIN) physical layer transceiver, compliant to LIN 2.0, LIN 2.1, LIN 2.2, LIN 2.2A and ISO/DIS 17987–4 standards, with integrated wake-up and protection features. The LIN bus is a single wire bidirectional bus typically used for low speed in-vehicle networks. The device transmitter supports data rates from 2.4 kbps to 20 kbps. The device receiver works up to 100 kbps supporting in-line programming. The LIN protocol data stream on the TXD input is converted by the TLIN2022A-Q1 into a LIN bus signal using a current-limited wave-shaping driver as outlined by the LIN physical layer specification. The receiver converts the data stream to logic-level signals that are sent to the microprocessor through the open-drain RXD pin. The LIN bus has two states: dominant state (voltage near ground) and recessive state (voltage near battery). In the recessive state, the LIN bus is pulled high by the internal pull-up resistor (45 k Ω) and a series diode. No external pull-up components are required for responder node applications. Commander node applications require an external pull-up resistor (1 k Ω) plus a series diode per the LIN specification.

The device is designed to support 12-V and 24-V applications with a wide input voltage operating range and also supports low-power sleep mode. The device also provides two methods to wake up: EN pin and from the LIN bus.

The TLIN2022A-Q1 integrates ESD protection and fault protection which allow for a reduction in the required external components in end applications. In the event of a ground shift or supply voltage disconnection, the device prevents back-feed current through LIN to the supply input. The device also includes undervoltage detection, temperature shutdown protection, and loss-of-ground protection.

9.2 Functional Block Diagram

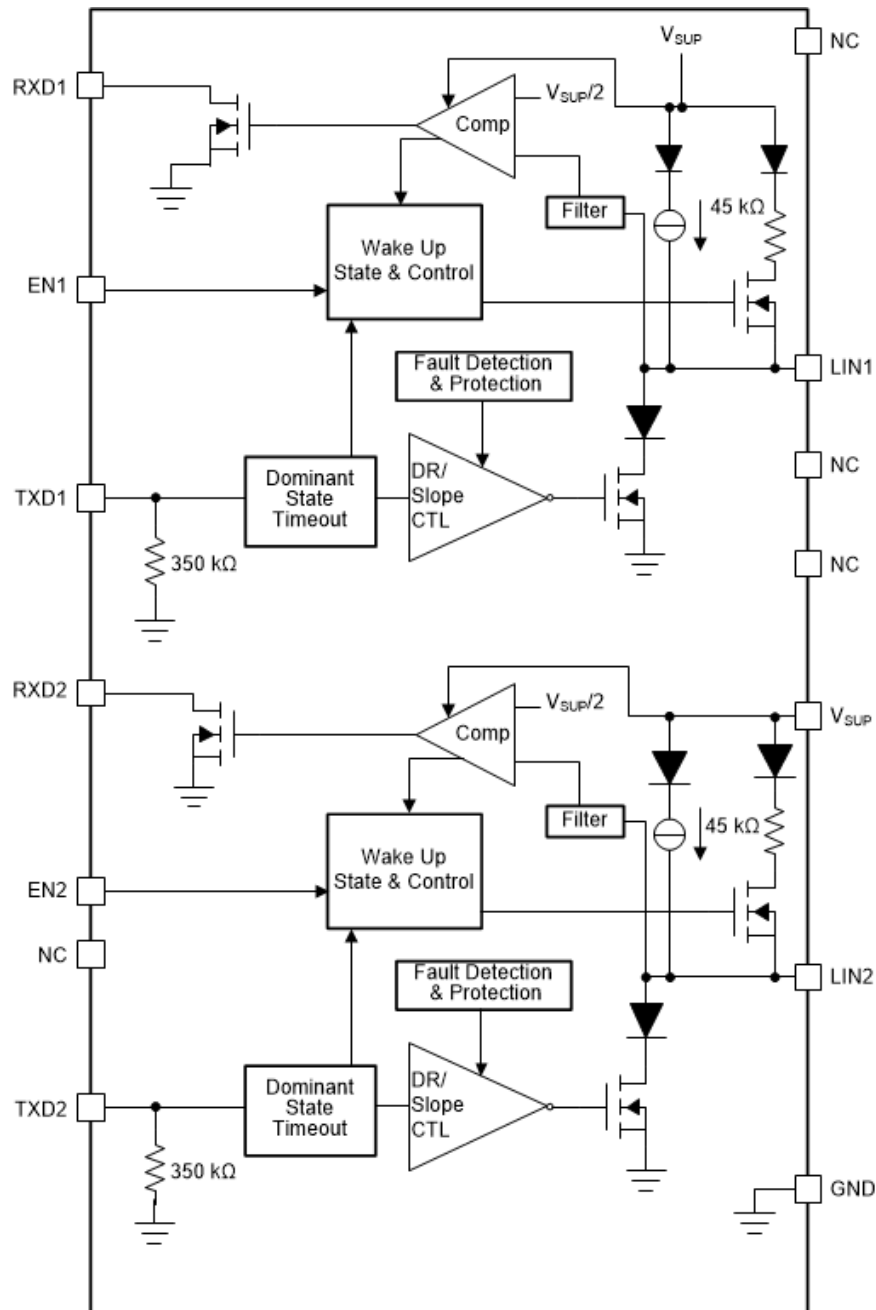

9.3 Feature Description

9.3.1 LIN (Local Interconnect Network) Bus

This high voltage input/output pin is a single wire LIN bus transmitter and receiver. The LIN pin can survive transient voltages up to 45 V. Reverse currents from the LIN to supply (V_{SUP}) are minimized with blocking diodes, even in the event of a ground shift or loss of supply (V_{SUP}).

9.3.1.1 LIN Transmitter Characteristics

The transmitter has thresholds and AC parameters according to the LIN specification. The transmitter is a low-side transistor with internal current limitation and thermal shutdown. During a thermal shut-down condition, the transmitter is disabled to protect the device. There is an internal pull-up resistor with a serial diode structure to

V_{SUP} , so no external pull-up components are required for the LIN responder node applications. An external pull-up resistor and series diode to V_{SUP} must be added when the device is used for a commander node application.

9.3.1.2 LIN Receiver Characteristics

The receiver characteristic thresholds are proportional to the device supply pin according to the LIN specification.

The receiver is capable of receiving higher data rates (> 100 kbps) than supported by LIN or SAEJ2602 specifications. This allows the TLIN2022A-Q1 to be used for high speed downloads at the end-of-line production or other applications. The actual data rate achievable depends on system time constants (bus capacitance and pull-up resistance) and driver characteristics used in the system.

9.3.1.2.1 Termination

There is an internal pull-up resistor with a serial diode structure to V_{SUP} , so no external pull-up components are required for the LIN responder node applications. An external pull-up resistor (1 k Ω) and a series diode to V_{SUP} must be added when the device is used for commander node applications as per the LIN specification.

Figure 9-1 shows a commander node configuration and how the voltage levels are defined

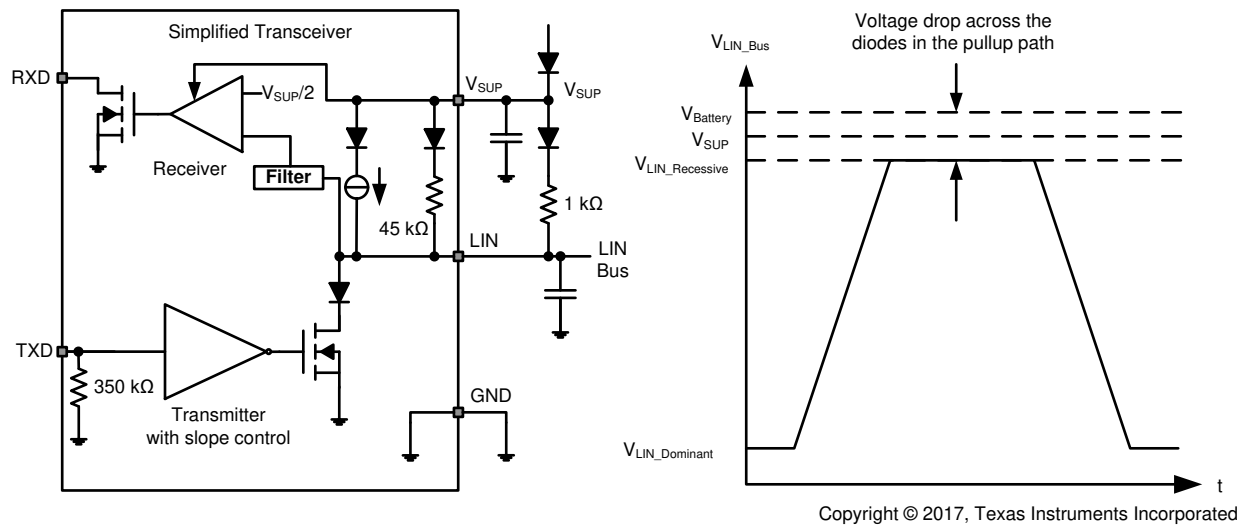

Figure 9-1. Commander Node Configuration with Voltage Levels

9.3.2 TXD

TXD is the interface to the MCU's LIN protocol controller or SCI / UART that is used to control the state of the LIN output. When TXD is low the LIN output is dominant (near ground). When TXD is high the LIN output is recessive (near $V_{Battery}$). See Figure 9-1. The TXD input structure is compatible with processors using 3.3 V and 5 V I/O. TXD has an internal pull-down resistor. The LIN bus is protected from being stuck dominant through a system failure driving TXD low through the dominant state timeout timer.

9.3.3 RXD (Receive Output)

RXD is the interface to the MCU's LIN protocol controller or SCI / UART, which reports the state of the LIN bus voltage. LIN recessive (near $V_{Battery}$) is represented by a high level on the RXD and LIN dominant (near ground) is represented by a low level on the RXD pin. The RXD output structure is an open-drain output stage. This allows the device to be used with 3.3 V and 5 V I/O processors. If the microcontroller's RXD pin does not have an integrated pull-up, an external pull-up resistor to the processors I/O supply voltage is required. In standby mode the RXD pin is driven low to indicate a wake up request from the LIN bus.

9.3.4 V_SUP (Supply Voltage)

V_{SUP} is the power supply pin. V_{SUP} is connected to the battery through an external reverse battery blocking diode (see Figure 9-1). If there is a loss of power at the ECU level, the device has low leakage from the LIN pin,

which does not load the bus down. This is optimal for LIN systems in which some of the nodes are unpowered (ignition supplied) while the rest of the network remains powered (battery supplied).

9.3.5 GND (Ground)

GND is the device ground connection. The device can operate with a ground shift as long as the ground shift does not reduce the V_{SUP} below the minimum operating voltage, as well as ensuring the input and output voltages are within their appropriate thresholds. If there is a loss of ground at the ECU level, the device has extremely low leakage from the LIN pin, which does not load the bus down. This is optimal for LIN systems in which some of the nodes are unpowered (ignition supplied) while the rest of the network remains powered (battery supplied).

9.3.6 EN (Enable Input)

EN1 and EN2 control the operational modes of the respective LIN channel. When EN1/EN2 is high the LIN1/LIN2 channel is in normal operating mode allowing a transmission path from TXD to respective LIN bus and from LIN to RXD. When EN1/EN2 is low the LIN1/LIN2 channel is put into sleep mode and there is no transmission path available. The channel can enter normal mode only after wake up. EN has an internal pull-down resistor to ensure the channel remains in low power mode even if EN floats.

9.3.7 Protection Features

The TLIN2022A-Q1 has several protection features.

9.3.8 TXD Dominant Time Out (DTO)

During normal mode, if TXD is inadvertently driven permanently low by a hardware or software application failure, the LIN bus is protected by the dominant state timeout timer. This timer is triggered by a falling edge on the TXD pin. If the low signal remains on TXD for longer than t_{DST} , the transmitter is disabled, thus allowing the LIN bus to return to recessive state and communication to resume on the bus. The protection is cleared and the t_{DST} timer is reset by a rising edge on TXD. The TXD pin has an internal pull-down to ensure the LIN channel fails to a known state if TXD is disconnected. During this fault, the LIN channel remains in normal mode (assuming no change of state request on EN), the transmitter is disabled, the RXD pin reflects the LIN bus and the LIN bus pull-up termination remains on.

9.3.9 Bus Stuck Dominant System Fault: False Wake-Up Lockout

The TLIN2022A-Q1 contains logic to detect bus stuck dominant system faults and prevents the device from waking up falsely during the system fault. Upon entering sleep mode, the device detects the state of the LIN bus. If the bus is dominant, the wake-up logic is locked out until a valid recessive on the bus “clears” the bus stuck dominant, preventing excessive current use. [Figure 9-2](#) and [Figure 9-3](#) show the behavior of this protection.

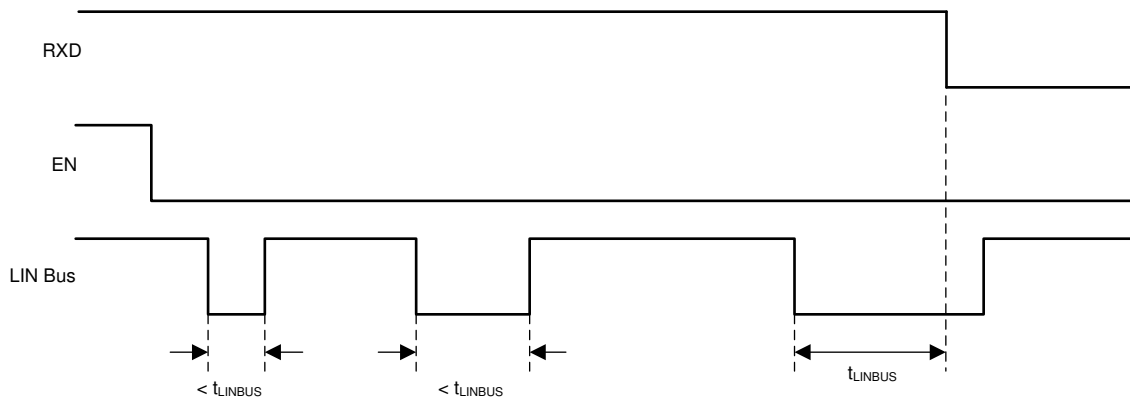

Figure 9-2. No Bus Fault: Entering Sleep Mode with Bus Recessive Condition and Wake-up



图 9-3. Bus Fault: Entering Sleep Mode with Bus Stuck Dominant Fault, Clearing, and Wake-up

9.3.10 Thermal Shutdown

The LIN transmitter is protected by limiting the current; however if the junction temperature of the device exceeds the thermal shutdown threshold, the device puts the LIN transmitter into the recessive state. Once the over-temperature fault condition has been removed and the junction temperature has cooled beyond the hysteresis temperature, the transmitter is re-enabled, assuming the device remained in the normal operation mode. During this fault, the transceiver remains in normal mode (assuming no change of state request on EN), the transmitter is in recessive state, the RXD pin reflects the LIN bus and LIN bus pull-up termination remains on.

9.3.11 Undervoltage on V_{SUP}

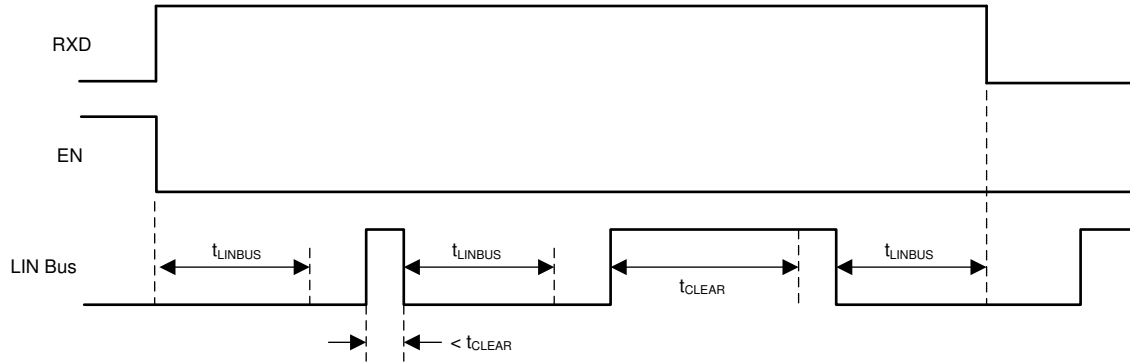
The TLIN2022A-Q1 contains a power on reset circuit to avoid false bus messages during undervoltage conditions when V_{SUP} is less than UV_{SUP} .

9.3.12 Unpowered Device and LIN Bus

In automotive applications some LIN nodes in a system can be unpowered (ignition supplied) while others in the network remains powered by the battery. The TLIN2022A-Q1 has a low unpowered leakage current from the bus so an unpowered node does not affect the network or load it down.

9.4 Device Functional Modes

The TLIN2022A-Q1 has three functional modes of operation; normal, sleep, and standby. The next sections describe these modes as well as how the device moves between the different modes. [图 9-4](#) graphically shows the relationship while [表 9-1](#) shows the state of pins.

表 9-1. Operating Modes

MODE	EN	RXD	LIN BUS TERMINATION	TRANSMITTER	COMMENT
Sleep	Low	Floating	Weak Current Pullup	Off	
Standby	Low	Low	45 kΩ (typical)	Off	Wake up event detected, waiting on MCU to set EN
Normal	High	LIN Bus Data	45 kΩ (typical)	Off	LIN transmission up to 20 kbps

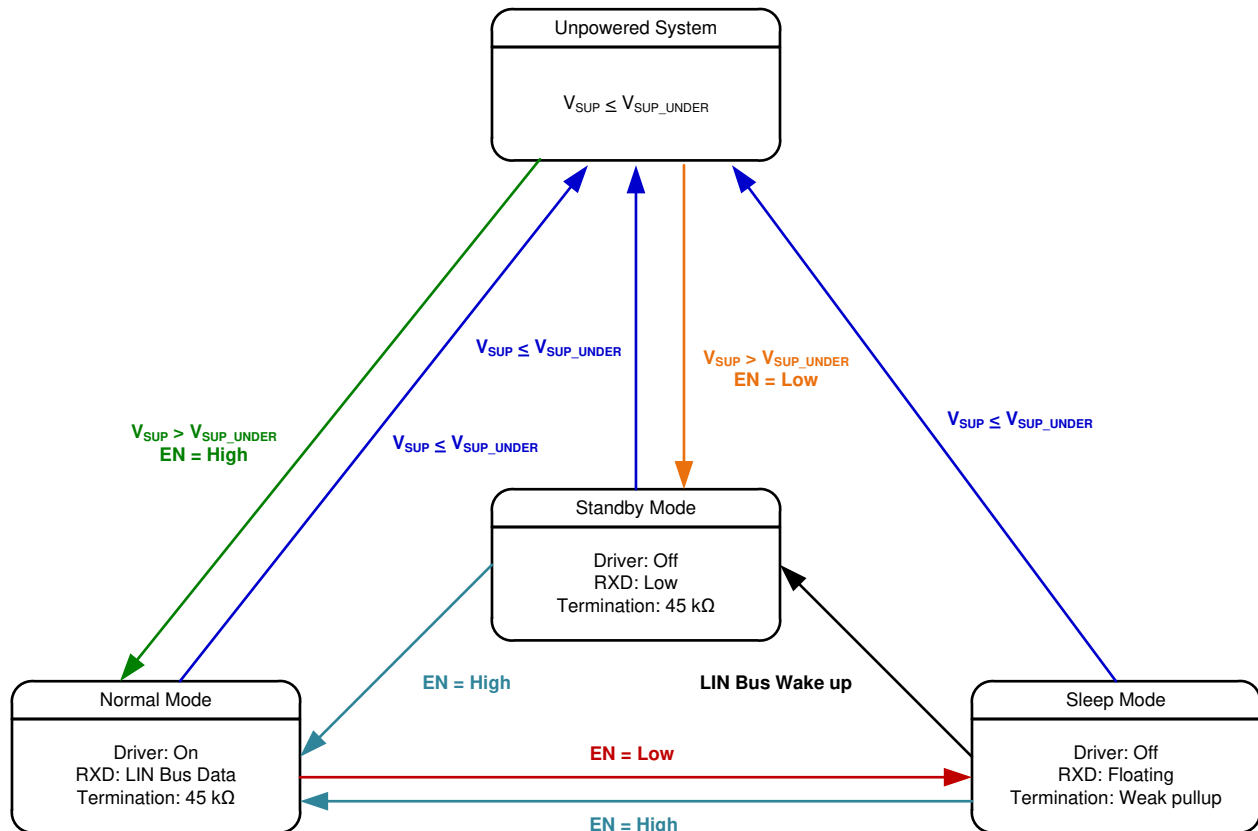

Copyright © 2017, Texas Instruments Incorporated

9-4. Operating State Diagram

9.4.1 Normal Mode

If the EN1 or EN2 pin is high at power up, the channel powers up in normal mode. If EN1 or EN2 is low, the channel powers up in standby mode. The EN pin controls the mode of the channel. In normal operational mode, the receiver and transmitter are active and the LIN transmission up to the LIN specified maximum of 20 kbps is supported. The receiver detects the data stream on the LIN bus and outputs it on RXD for the LIN controller. A recessive signal on the LIN bus is a logic high and a dominant signal on the LIN bus is a logic low. The driver transmits input data from TXD to the LIN bus. Normal mode is entered as EN transitions high while the LIN channel is in sleep or standby mode for $> t_{MODE_CHANGE}$ plus t_{NOMINT} .

9.4.2 Sleep Mode

Sleep Mode is the power saving mode for the TLIN2022A-Q1. Even with extremely low current consumption in this mode, the LIN channel can still wake-up from LIN bus through a wake-up signal or if EN is set high for $\geq t_{MODE_CHANGE}$. The LIN bus is filtered to prevent false wake-up events. The wake-up events must be active for the respective time periods (t_{LINBUS}).

Sleep mode is entered by setting EN low for longer than t_{MODE_CHANGE} .

While the channel is in sleep mode, the following conditions exist.

- The LIN bus driver is disabled and the internal LIN bus termination is switched off (to minimize power loss if LIN is short circuited to ground). However, the weak current pull-up is active to prevent false wake-up events in case an external connection to the LIN bus is lost.
- The normal receiver is disabled.
- EN input and LIN wake-up receiver are active.

9.4.3 Standby Mode

This mode is entered whenever a wake-up event occurs through the LIN bus while the channel is in sleep mode. The LIN bus responder termination circuit is turned on when standby mode is entered. Standby mode is signaled through a low level on RXD. See [Standby Mode Application Note](#) for more application information.

When EN is set high for longer than $t_{\text{MODE_CHANGE}}$ while the channel is in standby mode, the device returns to normal mode and the normal transmission paths from TXD to LIN bus and LIN bus to RXD are enabled.

9.4.4 Wake-Up Events

There are two ways to wake-up from sleep mode:

- Remote wake-up initiated by the falling edge of a recessive (high) to dominant (low) state transition on LIN bus where the dominant state is held for t_{LINBUS} filter time. After this t_{LINBUS} filter time has been met and a rising edge on the LIN bus going from dominant state to recessive state initiates a remote wake-up event, eliminating false wake-ups from disturbances on the LIN bus or if the bus is shorted to ground.
- Local wake-up through EN being set high for longer than $t_{\text{MODE_CHANGE}}$.

9.4.4.1 Wake-Up Request (RXD)

When the TLIN2022A-Q1 encounters a wake-up event from the LIN bus, RXD goes low and the channel transitions to standby mode until EN is reasserted high and the channel enters normal mode. Once the LIN channel enters normal mode, the RXD pin releases the wake-up request signal and the RXD pin then reflects the receiver output from the corresponding LIN bus.

9.4.4.2 Mode Transitions

When any of the LIN channel of TLIN2022A-Q1 is transitioning between modes, the device needs the time, $t_{\text{MODE_CHANGE}}$, to allow the change to fully propagate from the EN pin through the channel into the new state. When transitioning from sleep or standby mode to normal mode, the transition time is the sum of $t_{\text{MODE_CHANGE}}$ and t_{NOMINT}

10 Application Information Disclaimer

Note

Information in the following applications sections is not part of the TI component specification, and TI does not warrant its accuracy or completeness. TI's customers are responsible for determining suitability of components for their purposes, as well as validating and testing their design implementation to confirm system functionality.

10.1 Application Information

The TLIN2022A-Q1 can be used as both a responder node device and a commander node device in a LIN network. The device comes with the ability to support both remote wake-up request and local wake-up request.

10.2 Typical Application

The device comes with an integrated 45 k Ω pull-up resistor and series diode for responder node applications. For commander node applications, an external 1 k Ω pull-up resistor with series blocking diode can be used. [☒](#) [10-1](#) shows the device being used in both commander mode and responder mode applications.

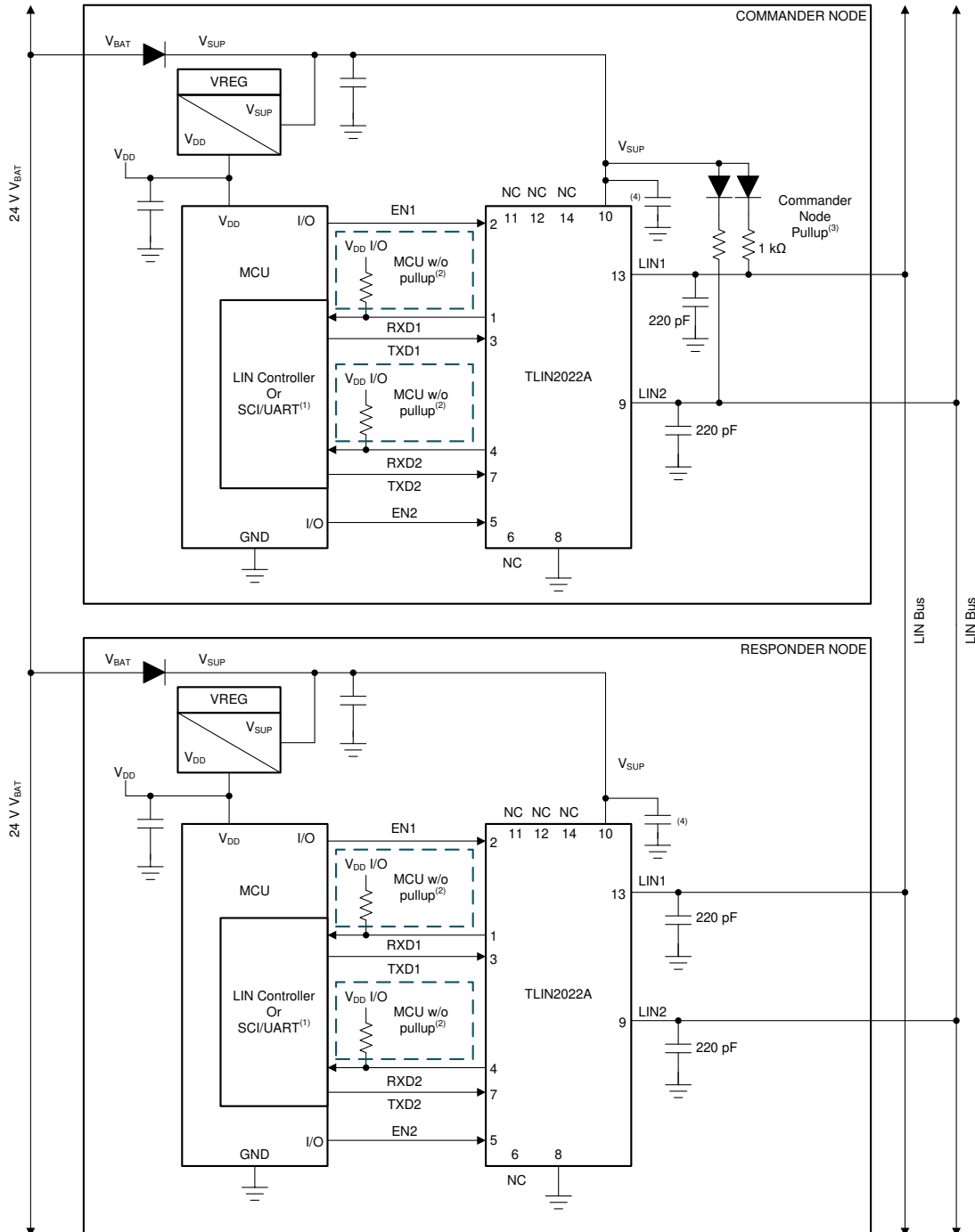

- A. If RXD on MCU or LIN responder has internal pullup; no external pullup resistor is needed.
- B. If RXD on MCU or LIN responder does not have an internal pullup requires external pullup resistor
- C. Commander node applications require an external 1 kΩ pullup resistor and serial diode.
- D. Decoupling capacitor values are system dependent but usually have 100 nF, 1 μF and ≥10 μF

10-1. Typical LIN Bus

10.2.1 Design Requirements

The RXD output structure is an open-drain output stage. This allows the TLIN2022A-Q1 to be used with 3.3-V and 5-V I/O processor. If the RXD pin of the processor does not have an integrated pull-up, an external pull-up resistor to the processor I/O supply voltage is required. The select external pull-up resistor value should be

between 1 kΩ to 10 kΩ, depending on supply used (See I_{OL} in electrical characteristics). The V_{SUP} pin of the device should be decoupled with a 100 nF capacitor by placing it close to the V_{SUP} supply pin. The system should include additional decoupling on the V_{SUP} line as needed per the application requirements.

10.2.2 Detailed Design Procedures

10.2.2.1 Normal Mode Application Note

When using the TLIN2022A-Q1 in systems which are monitoring the RXD pin for a wake up request, special care should be taken during the mode transitions. The output of the RXD pin is indeterminate for the transition period between states as the receivers are switched. The application software should not look for an edge on the RXD pin indicating a wake up request until t_{when going from normal to sleep mode} or t_{MODE_CHANGE} plus t_{NOMINT} when going from sleep or standby to normal mode. This is shown in [8-14](#).

10.2.2.2 Standby Mode Application Note

If the TLIN2022A-Q1 detects an undervoltage on V_{SUP} the RXD pin transitions low, and signals to the software that the TLIN2022A-Q1 is in standby mode and should be returned to sleep mode for the lowest power state.

10.2.2.3 TXD Dominant State Timeout Application Note

The maximum dominant TXD time allowed by the TXD dominant state time out limits the minimum possible data rate of the device. The LIN protocol has different constraints for commander and responder applications thus there are different maximum consecutive dominant bits for each application case and thus different minimum data rates.

10.2.3 Application Curves

[10-2](#) and [10-3](#) show the propagation delay from the TXD pin to the LIN pin for both dominant to recessive and recessive to dominant edges.

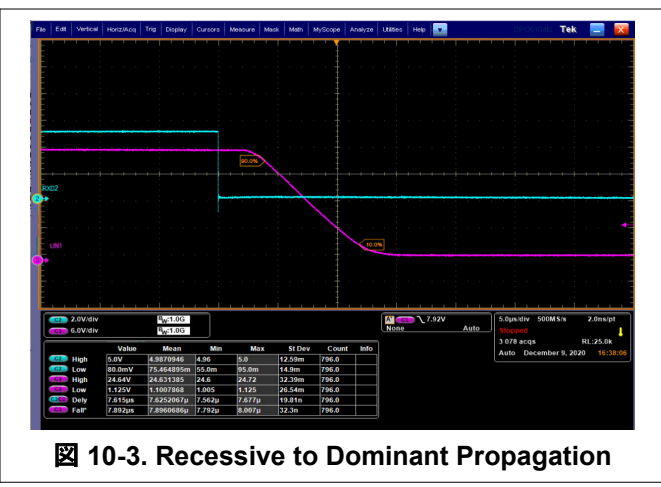
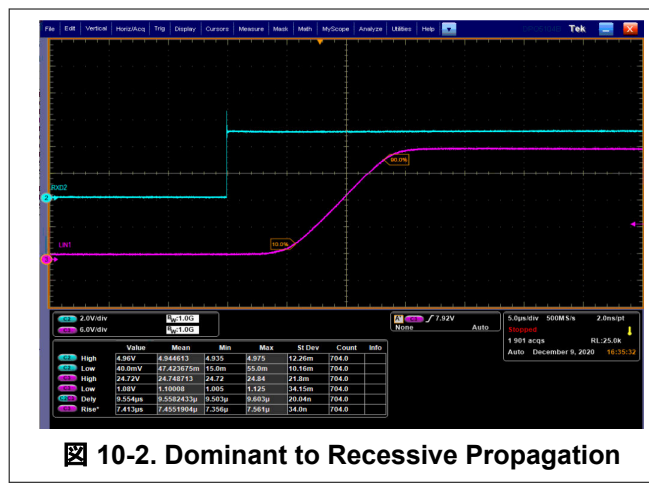

Power Supply Recommendations

The TLIN2022A-Q1 was designed to operate directly off a car battery, or any other DC supply ranging from 4 V to 48 V. A 100 nF decoupling capacitor should be placed as close to the V_{SUP} pin of the device as possible. It is good practice for some applications with noisier supplies to include 1 μ F and 10 μ F decoupling capacitor.

11 Layout

In order for the PCB design to be successful, start with the design of the protection and filtering circuitry. Because ESD and EFT transients have a wide frequency bandwidth from approximately 3 MHz to 3 GHz, high frequency layout techniques must be applied during PCB design. Placement at the connector also prevents these noisy events from propagating further into the PCB and system.

11.1 Layout Guidelines

- **Pin 1, 4 (RXD1/2):** The pin is an open-drain outputs and require an external pull-up resistor in the range of 1 k Ω and 10 k Ω to function properly. If the microprocessor paired with the transceiver does not have an integrated pull-up, an external resistor should be placed between RXD and the regulated voltage supply for the microprocessor.
- **Pin 2, 5 (EN1/2):** EN is an input pin that is used to place the device in a low power sleep mode. If this feature is not used, the pin should be pulled high to the regulated voltage supply of the microprocessor through a series resistor, values between 1 k Ω and 10 k Ω . Additionally, a series resistor may be placed on the pin to limit current on the digital lines in the event of an over voltage fault.
- **Pin 6 (NC):** Not Connected.
- **Pin 3, 7 (TXD1/2):** The TXD pins are the transmitter input signals to the device from the processor. A series resistor can be placed to limit the input current to the device in the case of an over-voltage on this pin. A capacitor to ground can be placed close to the input pin of the device to filter noise.
- **Pin 8 (GND):** This is the ground connection for the device. This pin should be tied to the ground plane through a short trace with the use of two vias to limit total return inductance.
- **Pin 9, 13 (LIN1/2):** This pin connects to the LIN bus. For responder node applications, a 220 pF capacitor to ground is implemented. For commander node applications and additional series resistor, a blocking diode should be placed between the LIN pin and the V_{SUP} pin. See [10-1](#).
- **Pin 10 (V_{SUP}):** This is the supply pin for the device. A 100 nF decoupling capacitor should be placed as close to the device as possible.
- **Pin 11, 12 and 14 (NC):** Not Connected.

Note

All ground and power connections should be made as short as possible and use at least two vias to minimize the total loop inductance.

11.2 Layout Example

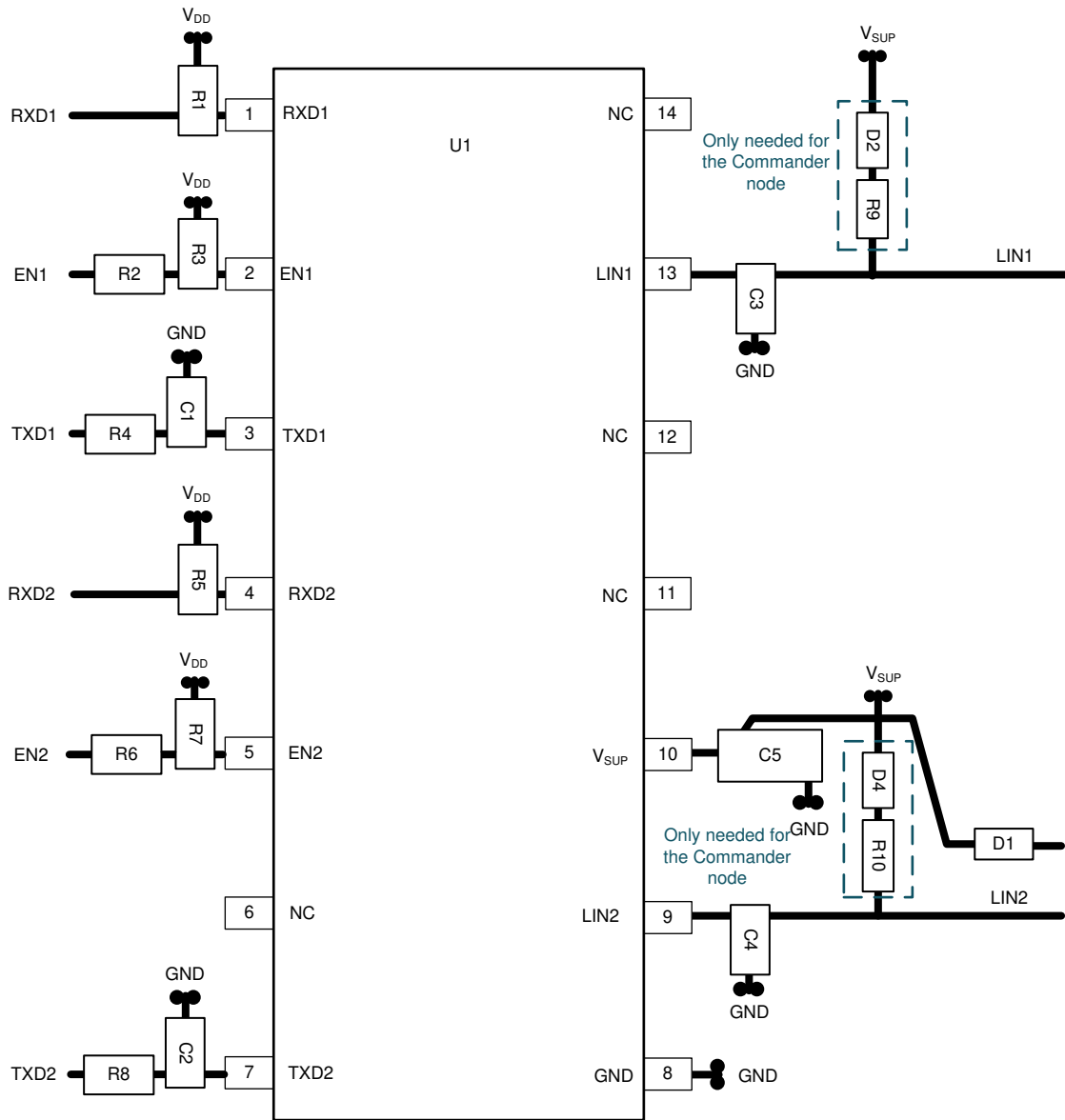

11-1. Layout Example

12 Device and Documentation Support

This device will conform to the following LIN standards. The core of what is needed is covered within this system spec, however reference should be made to these standards and any discrepancies pointed out and discussed. This document should provide all the basics of what is needed.

12.1 Documentation Support

12.1.1 Related Documentation

For related documentation see the following:

- LIN Standards:
 - ISO/DIS 17987-1: Road vehicles -- Local Interconnect Network (LIN) -- Part 1: General information and use case definition
 - ISO/DIS 17987-4: Road vehicles -- Local Interconnect Network (LIN) -- Part 4: Electrical Physical Layer (EPL) specification 12V/24V
 - SAEJ2602-1: LIN Network for Vehicle Applications
 - LIN2.0, LIN2.1, LIN2.2 and LIN2.2A specification
- EMC requirements:
 - SAEJ2962-1
 - ISO 10605: Road vehicles - Test methods for electrical disturbances from electrostatic discharge
 - ISO 11452-4:2011: Road vehicles - Component test methods for electrical disturbances from narrowband radiated electromagnetic energy - Part 4: Harness excitation methods
 - ISO 7637-1:2015: Road vehicles - Electrical disturbances from conduction and coupling - Part 1: Definitions and general considerations
 - ISO 7637-3: Road vehicles - Electrical disturbances from conduction and coupling - Part 3: Electrical transient transmission by capacitive and inductive coupling via lines other than supply lines
 - IEC 62132-4:2006: Integrated circuits - Measurement of electromagnetic immunity 150 kHz to 1 GHz - Part 4: Direct RF power injection method
 - IEC 61000-4-2
 - IEC 61967-4
 - CISPR25
- Conformance Test requirements:
 - ISO/DIS 17987-7: Road vehicles -- Local Interconnect Network (LIN) -- Part 7: Electrical Physical Layer (EPL) conformance test specification
 - SAEJ2602-2: LIN Network for Vehicle Applications Conformance Test
-

12.2 Receiving Notification of Documentation Updates

To receive notification of documentation updates, navigate to the device product folder on [ti.com](https://www.ti.com). Click on *Subscribe to updates* to register and receive a weekly digest of any product information that has changed. For change details, review the revision history included in any revised document.

12.3 サポート・リソース

[TI E2E™ サポート・フォーラム](#)は、エンジニアが検証済みの回答と設計に関するヒントをエキスパートから迅速かつ直接得ることができる場所です。既存の回答を検索したり、独自の質問をしたりすることで、設計に必要な支援を迅速に得ることができます。

リンクされているコンテンツは、該当する貢献者により、現状のまま提供されるものです。これらは TI の仕様を構成するものではなく、必ずしも TI の見解を反映したものではありません。TI の[使用条件](#)を参照してください。

12.4 Trademarks

TI E2E™ is a trademark of Texas Instruments.

すべての商標は、それぞれの所有者に帰属します。

12.5 Electrostatic Discharge Caution



This integrated circuit can be damaged by ESD. Texas Instruments recommends that all integrated circuits be handled with appropriate precautions. Failure to observe proper handling and installation procedures can cause damage.

ESD damage can range from subtle performance degradation to complete device failure. Precision integrated circuits may be more susceptible to damage because very small parametric changes could cause the device not to meet its published specifications.

12.6 Glossary

[TI Glossary](#) This glossary lists and explains terms, acronyms, and definitions.

13 Mechanical, Packaging, and Orderable Information

The following pages include mechanical, packaging, and orderable information. This information is the most current data available for the designated devices. This data is subject to change without notice and revision of this document. For browser-based versions of this data sheet, refer to the left-hand navigation.

PACKAGING INFORMATION

Orderable Device	Status (1)	Package Type	Package Drawing	Pins	Package Qty	Eco Plan (2)	Lead finish/ Ball material (6)	MSL Peak Temp (3)	Op Temp (°C)	Device Marking (4/5)	Samples
TLIN2022ADMTRQ1	ACTIVE	VSON	DMT	14	3000	RoHS & Green	SN	Level-2-260C-1 YEAR	-40 to 125	T022A	Samples
TLIN2022ADRQ1	ACTIVE	SOIC	D	14	2500	RoHS & Green	NIPDAU NIPDAUAG	Level-1-260C-UNLIM	-40 to 125	TL022A	Samples

(1) The marketing status values are defined as follows:

ACTIVE: Product device recommended for new designs.

LIFEBUY: TI has announced that the device will be discontinued, and a lifetime-buy period is in effect.

NRND: Not recommended for new designs. Device is in production to support existing customers, but TI does not recommend using this part in a new design.

PREVIEW: Device has been announced but is not in production. Samples may or may not be available.

OBSOLETE: TI has discontinued the production of the device.

(2) **RoHS:** TI defines "RoHS" to mean semiconductor products that are compliant with the current EU RoHS requirements for all 10 RoHS substances, including the requirement that RoHS substance do not exceed 0.1% by weight in homogeneous materials. Where designed to be soldered at high temperatures, "RoHS" products are suitable for use in specified lead-free processes. TI may reference these types of products as "Pb-Free".

RoHS Exempt: TI defines "RoHS Exempt" to mean products that contain lead but are compliant with EU RoHS pursuant to a specific EU RoHS exemption.

Green: TI defines "Green" to mean the content of Chlorine (Cl) and Bromine (Br) based flame retardants meet JS709B low halogen requirements of <=1000ppm threshold. Antimony trioxide based flame retardants must also meet the <=1000ppm threshold requirement.

(3) MSL, Peak Temp. - The Moisture Sensitivity Level rating according to the JEDEC industry standard classifications, and peak solder temperature.

(4) There may be additional marking, which relates to the logo, the lot trace code information, or the environmental category on the device.

(5) Multiple Device Markings will be inside parentheses. Only one Device Marking contained in parentheses and separated by a "~" will appear on a device. If a line is indented then it is a continuation of the previous line and the two combined represent the entire Device Marking for that device.

(6) Lead finish/Ball material - Orderable Devices may have multiple material finish options. Finish options are separated by a vertical ruled line. Lead finish/Ball material values may wrap to two lines if the finish value exceeds the maximum column width.

Important Information and Disclaimer:The information provided on this page represents TI's knowledge and belief as of the date that it is provided. TI bases its knowledge and belief on information provided by third parties, and makes no representation or warranty as to the accuracy of such information. Efforts are underway to better integrate information from third parties. TI has taken and continues to take reasonable steps to provide representative and accurate information but may not have conducted destructive testing or chemical analysis on incoming materials and chemicals. TI and TI suppliers consider certain information to be proprietary, and thus CAS numbers and other limited information may not be available for release.

In no event shall TI's liability arising out of such information exceed the total purchase price of the TI part(s) at issue in this document sold by TI to Customer on an annual basis.

GENERIC PACKAGE VIEW

DMT 14

VSON - 0.9 mm max height

3 x 4.5, 0.65 mm pitch

PLASTIC SMALL OUTLINE - NO LEAD

This image is a representation of the package family, actual package may vary.
Refer to the product data sheet for package details.

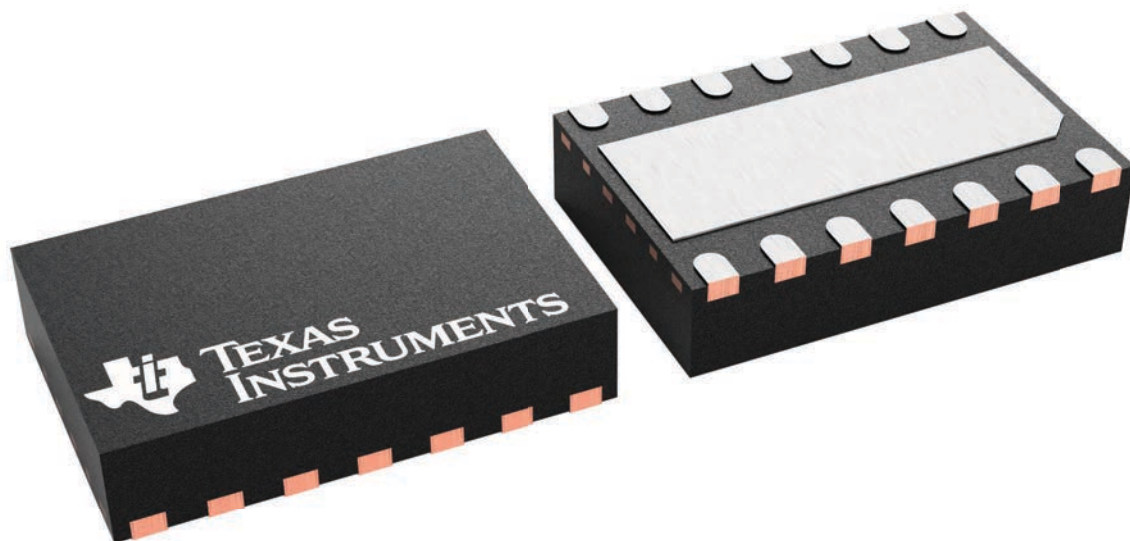

4225088/A

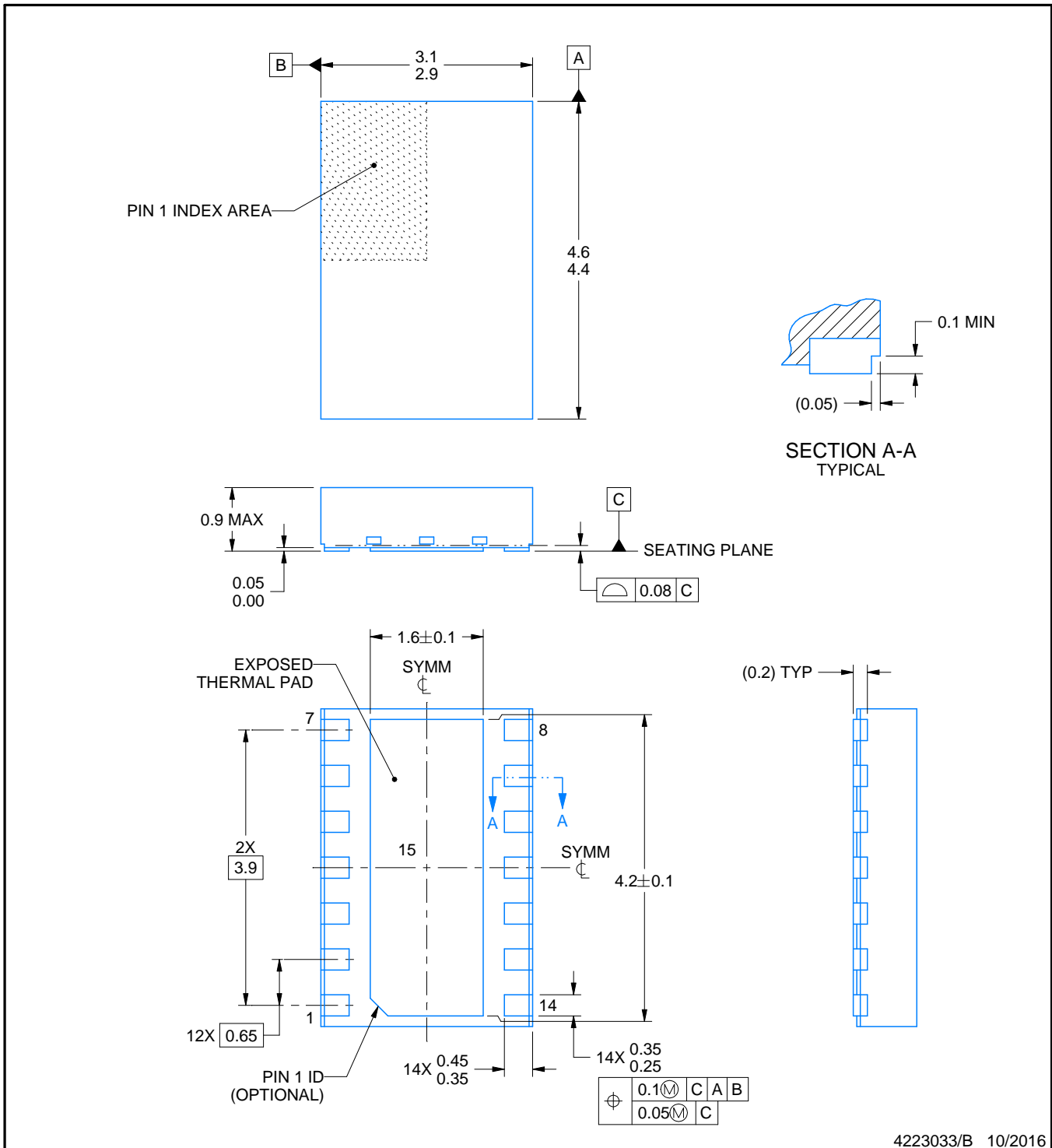

4223033/B 10/2016

NOTES:

1. All linear dimensions are in millimeters. Any dimensions in parenthesis are for reference only. Dimensioning and tolerancing per ASME Y14.5M.
2. This drawing is subject to change without notice.
3. The package thermal pad must be soldered to the printed circuit board for thermal and mechanical performance.

EXAMPLE BOARD LAYOUT

DMT0014A

VSON - 0.9 mm max height

PLASTIC SMALL OUTLINE - NO LEAD

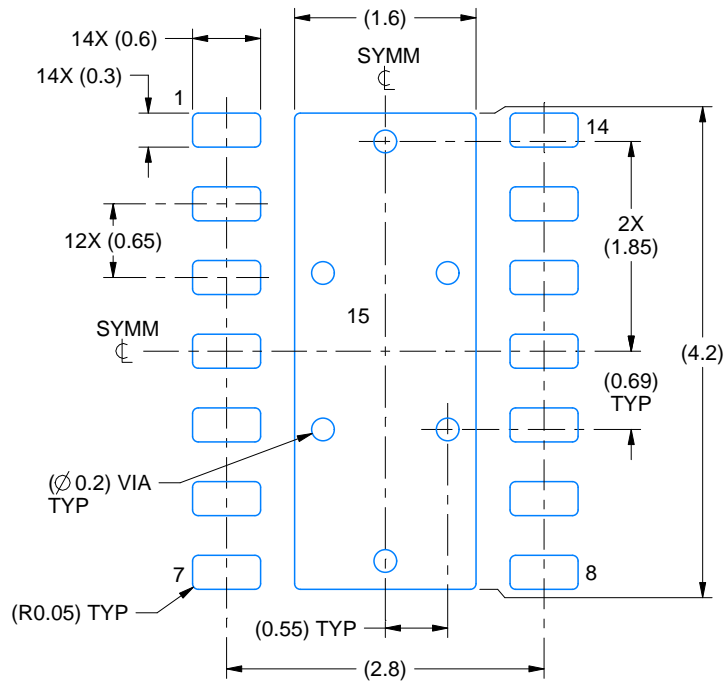

LAND PATTERN EXAMPLE
SCALE:15X

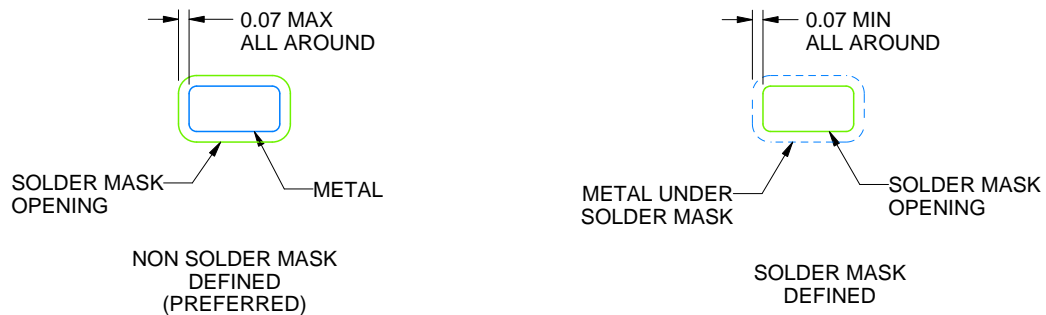

SOLDER MASK DETAILS

4223033/B 10/2016

NOTES: (continued)

4. This package is designed to be soldered to a thermal pad on the board. For more information, see Texas Instruments literature number SLUA271 (www.ti.com/lit/slua271).
5. Vias are optional depending on application, refer to device data sheet. If any vias are implemented, refer to their locations shown on this view. It is recommended that vias under paste be filled, plugged or tented.

EXAMPLE STENCIL DESIGN

DMT0014A

VSON - 0.9 mm max height

PLASTIC SMALL OUTLINE - NO LEAD

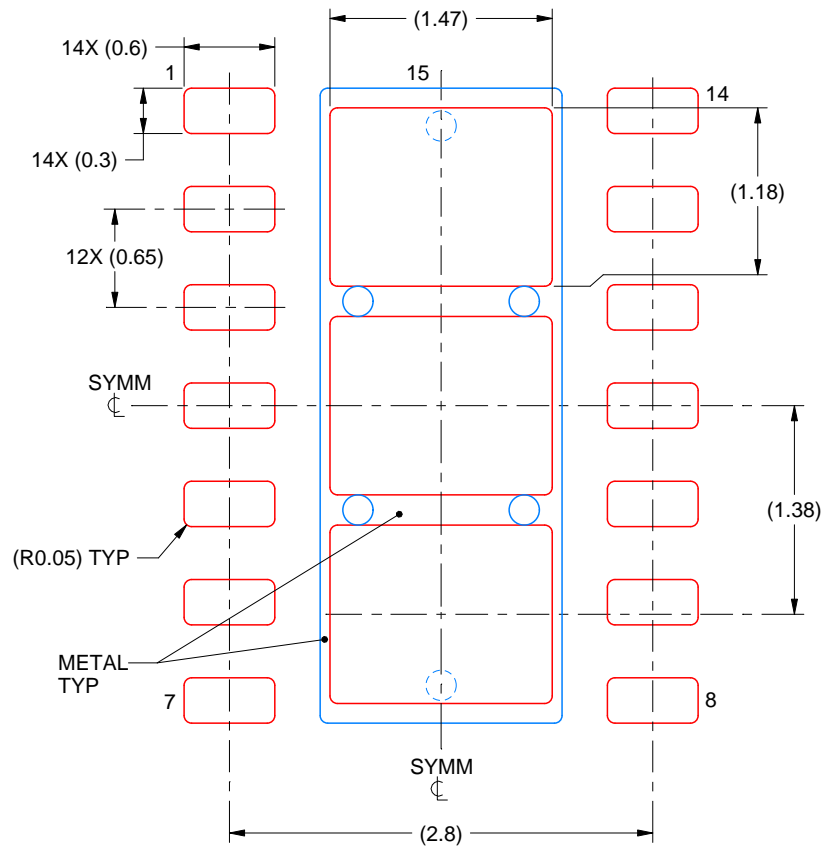

SOLDER PASTE EXAMPLE
BASED ON 0.125 mm THICK STENCIL
EXPOSED PAD 15
77.4% PRINTED SOLDER COVERAGE BY AREA
SCALE:20X

4223033/B 10/2016

NOTES: (continued)

6. Laser cutting apertures with trapezoidal walls and rounded corners may offer better paste release. IPC-7525 may have alternate design recommendations.

D (R-PDSO-G14)

PLASTIC SMALL OUTLINE



- NOTES:
- A. All linear dimensions are in inches (millimeters).
 - B. This drawing is subject to change without notice.
 -  Body length does not include mold flash, protrusions, or gate burrs. Mold flash, protrusions, or gate burrs shall not exceed 0.006 (0,15) each side.
 -  Body width does not include interlead flash. Interlead flash shall not exceed 0.017 (0,43) each side.
 - E. Reference JEDEC MS-012 variation AB.

D (R-PDSO-G14)

PLASTIC SMALL OUTLINE



- NOTES:
- A. All linear dimensions are in millimeters.
 - B. This drawing is subject to change without notice.
 - C. Publication IPC-7351 is recommended for alternate designs.
 - D. Laser cutting apertures with trapezoidal walls and also rounding corners will offer better paste release. Customers should contact their board assembly site for stencil design recommendations. Refer to IPC-7525 for other stencil recommendations.
 - E. Customers should contact their board fabrication site for solder mask tolerances between and around signal pads.

重要なお知らせと免責事項

TI は、技術データと信頼性データ（データシートを含みます）、設計リソース（リファレンス・デザインを含みます）、アプリケーションや設計に関する各種アドバイス、Web ツール、安全性情報、その他のリソースを、欠陥が存在する可能性のある「現状のまま」提供しており、商品性および特定目的に対する適合性の黙示保証、第三者の知的財産権の非侵害保証を含むいかなる保証も、明示的または黙示的にかかわらず拒否します。

これらのリソースは、TI 製品を使用する設計の経験を積んだ開発者への提供を意図したものです。(1) お客様のアプリケーションに適した TI 製品の選定、(2) お客様のアプリケーションの設計、検証、試験、(3) お客様のアプリケーションに該当する各種規格や、その他のあらゆる安全性、セキュリティ、規制、または他の要件への確実な適合に関する責任を、お客様のみが単独で負うものとし、

上記の各種リソースは、予告なく変更される可能性があります。これらのリソースは、リソースで説明されている TI 製品を使用するアプリケーションの開発の目的でのみ、TI はその使用をお客様に許諾します。これらのリソースに関して、他の目的で複製することや掲載することは禁止されています。TI や第三者の知的財産権のライセンスが付与されている訳ではありません。お客様は、これらのリソースを自身で使用した結果発生するあらゆる申し立て、損害、費用、損失、責任について、TI およびその代理人を完全に補償するものとし、TI は一切の責任を拒否します。

TI の製品は、[TI の販売条件](#)、または [ti.com](#) やかかる TI 製品の関連資料などのいずれかを通じて提供する適用可能な条項の下で提供されています。TI がこれらのリソースを提供することは、適用される TI の保証または他の保証の放棄の拡大や変更を意味するものではありません。

お客様がいかなる追加条項または代替条項を提案した場合でも、TI はそれらに異議を唱え、拒否します。

郵送先住所：Texas Instruments, Post Office Box 655303, Dallas, Texas 75265
Copyright © 2024, Texas Instruments Incorporated