

TLV185x および TLV186x 40V ナノパワー・コンパレータ・ファミリ

1 特長

- 低い消費電流: チャンネルごとに 440nA
- 幅広い電源電圧範囲: 1.8V~40V
- レール上の入力: (V+) とは無関係に、同相範囲は (V-) + 40V まで
- フェイルセーフ: 電源なしの高インピーダンス入力
- 既知の起動条件を提供するパワーオン・リセット
- オーバードライブ入力についても位相反転なし
- 最高 40V までの逆バッテリー保護
- プッシュプル出力オプション (TLV185x)
- オープン・ドレイン出力オプション (TLV186x)
- 温度範囲: -40°C ~ +125°C

2 アプリケーション

- 携帯電話、タブレット
- ヘッドセット / ヘッドホン、小型イヤホン
- PC、ノート PC
- ガス検出器
- 煙感知器、熱感知器
- モーション検出器
- ガス・メータ
- サーボ・ドライブ位置センサ

3 概要

TLV185x および TLV186x は、シングル、デュアル、クワッド・チャンネル・オプションを備えたナノパワー 40V コンパレータ・ファミリです。このファミリには、フェイルセーフ (FS) 入力と、プッシュプルおよびオープン・ドレインの出力オプションがあります。これらの機能と、1.8V~40V の幅広い電源電圧範囲にわたるナノパワー動作により、このファミリ

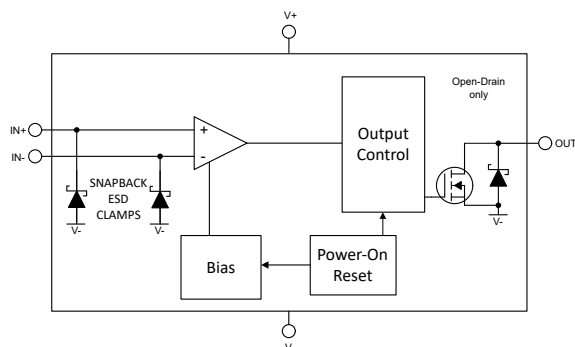

ブロック図

は低消費電力の常時オン・システムでの電圧および温度監視などのハウスキーピング機能に最適です。

すべてのデバイスにパワーオン・リセット (POR) 機能が搭載され、出力が入力に応答する前、最小電源電圧に達するまでの間、出力が既知の状態であることが保証されるため、システムの電源投入時および電源切断時に誤った出力が発生されるのを防止できます。

入力はオーバー・ザ・レール機能を備えており、両方の入力が最大 40 V の電源電圧を超えても正常に動作します。このため、このコンパレータは、比較可能な入力電圧の範囲を制限することなく、高電源電圧と低電源電圧の両方のシステムに適しています。同様に、内蔵の逆バッテリー保護機能により、電源ピンにバッテリーが不適切に取り付けられた場合のコンパレータの損傷を防止します。

TLV185x コンパレータにはプッシュプル出力段があるのに対して、TLV186x コンパレータは、オープン・ドレイン出力段があるためレベル変換に適しています。

製品情報

部品番号	パッケージ (1)	本体サイズ (公称)
TLV1851, TLV1861	SOT-23 (5)	1.60mm × 2.90mm
TLV1852, TLV1862	SOIC (8) (プレビュー)	3.91mm × 4.90mm
	VSSOP (8) (プレビュー)	3.00mm × 3.00mm
TLV1854, TLV1864	SOIC (14) (プレビュー)	3.91mm × 8.65mm
	TSSOP (14) (プレビュー)	4.40mm × 5.00mm

- (1) 利用可能なすべてのパッケージについては、データシートの末尾にある注文情報を参照してください。

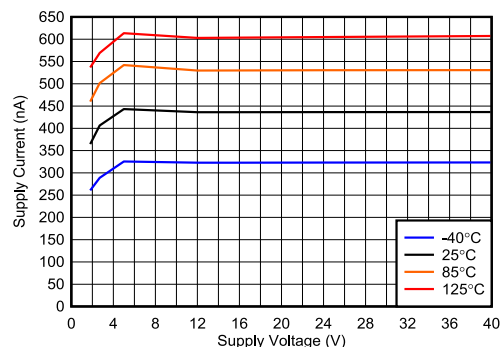

消費電流と電源電圧の関係



Table of Contents

1 特長	1	7.3 Feature Description.....	16
2 アプリケーション	1	7.4 Device Functional Modes.....	16
3 概要	1	8 Application and Implementation	20
4 Revision History	2	8.1 Application Information.....	20
5 Pin Configuration and Functions	3	8.2 Typical Applications.....	23
Pin Configuration: TLV1851 and TLV1861.....	3	8.3 Power Supply Recommendations.....	25
Pin Configurations: TLV1852 and TLV1862.....	4	9 Layout	27
Pin Configurations: TLV1854 and TLV1864.....	5	9.1 Layout Guidelines.....	27
6 Specifications	6	9.2 Layout Example.....	27
6.1 Absolute Maximum Ratings.....	6	10 デバイスおよびドキュメントのサポート	28
6.2 ESD Ratings.....	6	10.1 Documentation Support.....	28
6.3 Thermal Information.....	6	10.2 ドキュメントの更新通知を受け取る方法.....	28
6.4 Recommended Operating Conditions.....	7	10.3 サポート・リソース.....	28
6.5 Electrical Characteristics.....	8	10.4 Trademarks.....	28
6.6 Switching Characteristics.....	9	10.5 静電気放電に関する注意事項.....	28
6.7 Typical Characteristics.....	10	10.6 用語集.....	28
7 Detailed Description	16	11 Mechanical, Packaging, and Orderable Information	28
7.1 Overview.....	16		
7.2 Functional Block Diagrams.....	16		

4 Revision History

資料番号末尾の英字は改訂を表しています。その改訂履歴は英語版に準じています。

Changes from Revision * (December 2022) to Revision A (January 2023)	Page
• TLV1851 の量産データのリリース.....	1

5 Pin Configuration and Functions

Pin Configuration: TLV1851 and TLV1861

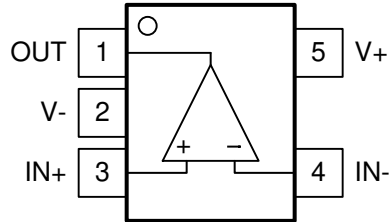

**DBV Package
SOT-23-5
Top View
(Standard "north west" pinout)**

表 5-1. Pin Functions: TLV1851 and TLV1861

PIN		I/O	DESCRIPTION
NAME	NO.		
OUT	1	O	Output
V-	2	-	Negative supply voltage
IN+	3	I	Non-inverting (+) input
IN-	4	I	Inverting (-) input
V+	5	-	Positive supply voltage

Pin Configurations: TLV1852 and TLV1862



表 5-2. Pin Functions: TLV1852 and TLV1862

PIN		I/O	DESCRIPTION
NAME	NO.		
OUT1	1	O	Output pin of the comparator 1
IN1-	2	I	Inverting input pin of comparator 1
IN1+	3	I	Noninverting input pin of comparator 1
V-	4	—	Negative supply voltage
IN2+	5	I	Noninverting input pin of comparator 2
IN2-	6	I	Inverting input pin of comparator 2
OUT2	7	O	Output pin of the comparator 2
V+	8	—	Positive supply voltage

Pin Configurations: TLV1854 and TLV1864

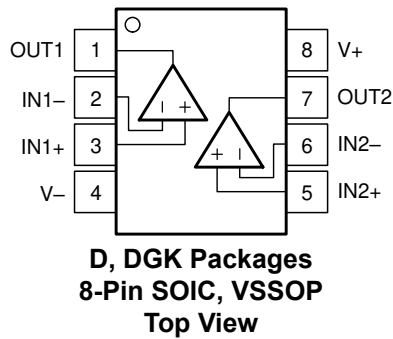

表 5-3. Pin Functions: TLV1854 and TLV1864

PIN		I/O	DESCRIPTION
NAME	NO.		
OUT1	1	O	Output pin of the comparator 1
IN1-	2	I	Negative input pin of the comparator 1
IN1+	3	I	Positive input pin of the comparator 1
V+	4	-	Positive supply voltage
IN2+	5	I	Positive input pin of the comparator 2
IN2-	6	I	Negative input pin of the comparator 2
OUT2	7	O	Output pin of the comparator 2
OUT3	8	O	Output pin of the comparator 3
IN3-	9	I	Negative input pin of the comparator 3
IN3+	10	I	Positive input pin of the comparator 3
V-	11	-	Negative supply voltage
IN4+	12	I	Positive input pin of the comparator 4
IN4-	13	I	Negative input pin of the comparator 4
OUT4	14	O	Output pin of the comparator 4

6 Specifications

6.1 Absolute Maximum Ratings

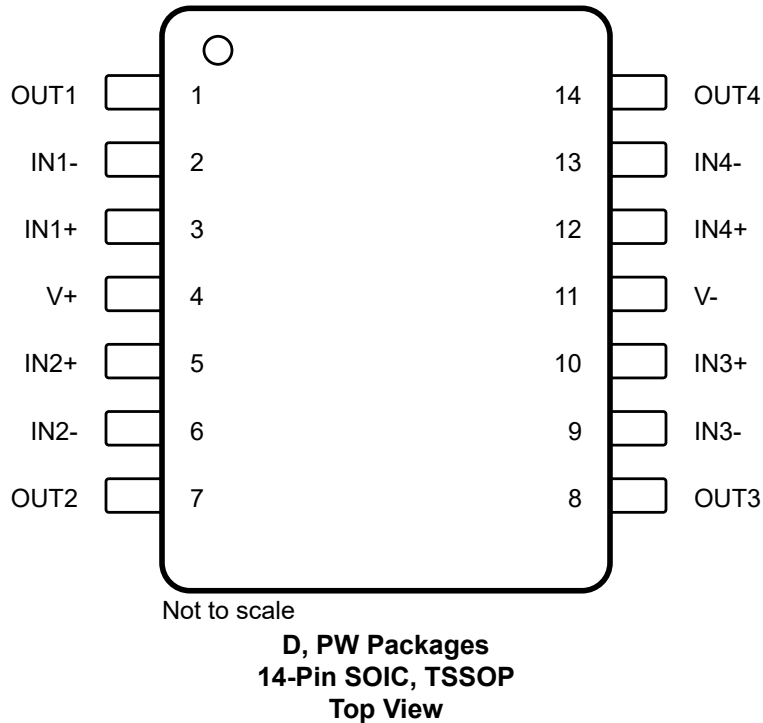
over operating free-air temperature range (unless otherwise noted)⁽¹⁾

	MIN	MAX	UNIT
Supply voltage: $V_S = (V+) - (V-)$		42	V
Differential Input Voltage, VID	-42	42	V
Input pins (IN+, IN-) from (V-) ⁽²⁾	-0.3	42	V
Current into Input pins (IN+, IN-) ⁽³⁾	-10	10	mA
Output (Open-drain version only) from (V-) ⁽⁴⁾	-0.3	42	V
Output (OUT) (Push-Pull) from (V-)	-0.3	(V+) + 0.3	V
Output short circuit current ⁽⁵⁾	-10	10	mA
Junction temperature, T_J		150	°C
Storage temperature, T_{stg}	-65	150	°C

- (1) Stresses beyond those listed under *Absolute Maximum Ratings* may cause permanent damage to the device. These are stress ratings only, which do not imply functional operation of the device at these or any other conditions beyond those indicated under *Recommended Operating Conditions*. Exposure to absolute-maximum-rated conditions for extended periods may affect device reliability.
- (2) Input terminals are diode-clamped to (V-). Inputs (IN+, IN-) can be greater than (V+) and OUT as long as it is within the -0.3 V to 42 V range
- (3) Input terminals are diode-clamped to (V-). Input signals that swing more than 0.3 V below (V-) must be current-limited to 10 mA or less.
- (4) Output (OUT) for open drain can be greater than (V+) and inputs (IN+, IN-) as long as it is within the -0.3 V to 42 V range
- (5) Short-circuit to (V-) or (V+).

6.2 ESD Ratings

		VALUE	UNIT
$V_{(ESD)}$	Electrostatic discharge	Human-body model (HBM), per ANSI/ESDA/JEDEC JS-001 ⁽¹⁾	±2000
		Charged-device model (CDM), per ANSI/ESDA/JEDEC JS-002 ⁽²⁾	±1500

- (1) JEDEC document JEP155 states that 500 V HBM allows safe manufacturing with a standard ESD control process.
- (2) JEDEC document JEP157 states that 250 V CDM allows safe manufacturing with a standard ESD control process.

6.3 Thermal Information

THERMAL METRIC ⁽¹⁾		TLV185x/6x					UNIT
		DBV (SOT-23)	D (SOIC)	DGK (VSSOP)	PW (TSSOP)	D (SOIC)	
		5 Pins	8 Pins	8 Pins	14 Pins	14 Pins	
R_{qJA}	Junction-to-ambient thermal resistance	168.1	121.6	163.1			°C/W
$R_{qJC(top)}$	Junction-to-case (top) thermal resistance	68.1	64.6	55.5			°C/W
R_{qJB}	Junction-to-board thermal resistance	37.4	65.1	84.7			°C/W
γ_{JT}	Junction-to-top characterization parameter	11.4	18.1	5.7			°C/W
γ_{JB}	Junction-to-board characterization parameter	37.1	64.3	83.1			°C/W
$R_{qJC(bot)}$	Junction-to-case (bottom) thermal resistance						°C/W

- (1) For more information about traditional and new thermal metrics, see the [Semiconductor and IC Package Thermal Metrics](#) application report.

6.4 Recommended Operating Conditions

over operating free-air temperature range (unless otherwise noted)

	MIN	MAX	UNIT
Supply voltage: $V_S = (V+) - (V-)$	1.8	40	V
Input voltage range from (V-)	-0.1	40	V
Common-mode input voltage range from (V-)	0	40	V
Output voltage for open drain from (V-)	-0.1	40	V
Ambient temperature, T_A	-40	125	°C

6.5 Electrical Characteristics

For $V_S = (V+) - (V-) = 12V$, $V_{CM} = V_S/2$ at $T_A = 25^\circ C$ (Unless otherwise noted)

PARAMETER		TEST CONDITIONS	MIN	TYP	MAX	UNIT
OFFSET VOLTAGE						
V_{OS}	Input offset voltage		-3.6	±0.25	3.6	mV
V_{OS}	Input offset voltage	$T_A = -40^\circ C$ to $+125^\circ C$	-4.4		4.4	mV
dV_{IO}/dT	Input offset voltage drift			3		$\mu V/^\circ C$
V_{HYS}	Input hysteresis voltage		1	2.8	5	mV
$V_{CM-Range}$	Common-mode voltage range from (V-)	$V_S = 1.8 V$ to $40 V$ $T_A = -40^\circ C$ to $+125^\circ C$	0		40	V
POWER SUPPLY						
I_Q	Quiescent current per comparator (output high)	Push Pull Output Option		520	750	nA
I_Q	Quiescent current per comparator (output high)	Push Pull Output Option, $T_A = -40^\circ C$ to $125^\circ C$			1000	nA
I_Q	Quiescent current per comparator (output high)	Open Drain Output option, no pull-up resistor		440	640	nA
I_Q	Quiescent current per comparator (output high)	Open Drain Output option, no pull-up resistor, $T_A = -40^\circ C$ to $125^\circ C$			850	nA
V_{POR}		During power on, V_S must exceed V_{POR} for t_{ON} before the output will reflect the input.		1.5		V
INPUT BIAS CURRENT						
I_B	Input bias current ⁽¹⁾			1	250	pA
		$T_A = -40^\circ C$ to $+125^\circ C$			1500	pA
I_{OS}	Input offset current ⁽¹⁾			0.1	100	pA
		$T_A = -40^\circ C$ to $+125^\circ C$			1000	pA
OUTPUT						
V_{OL}	Voltage swing from (V-)	$I_{SINK} = 2 \mu A$		1		mV
V_{OL}	Voltage swing from (V-)	$I_{SINK} = 50 \mu A$		20	60	mV
		$I_{SINK} = 50 \mu A$ $T_A = -40^\circ C$ to $+125^\circ C$			100	mV
V_{OH}	Voltage swing from (V+) (Push Pull only)	$I_{SOURCE} = 2 \mu A$		1		mV
V_{OH}	Voltage swing from (V+) (Push Pull only)	$I_{SOURCE} = 50 \mu A$		25	60	mV
		$I_{SOURCE} = 50 \mu A$ $T_A = -40^\circ C$ to $+125^\circ C$			100	mV
I_{LKG}	Open-drain output leakage current	$V_{ID} = +0.1 V$, $V_{PULLUP} = (V+)$		0.3		pA
I_{OL}	Short-circuit current	Sinking $T_A = -40^\circ C$ to $+125^\circ C$		7		mA

6.5 Electrical Characteristics (continued)

For $V_S = (V+) - (V-) = 12V$, $V_{CM} = V_S/2$ at $T_A = 25^\circ C$ (Unless otherwise noted)

PARAMETER		TEST CONDITIONS	MIN	TYP	MAX	UNIT
I_{OH}	Short-circuit current	Sourcing (for Push-Pull only) $T_A = -40^\circ C$ to $+125^\circ C$		5		mA

(1) This parameter is ensured by design and/or characterization and is not tested in production.

6.6 Switching Characteristics

For $V_S = (V+) - (V-) = 12V$, $V_{CM} = V_S/2$ at $T_A = 25^\circ C$ (Unless otherwise noted)

PARAMETER		TEST CONDITIONS	MIN	TYP	MAX	UNIT
OUTPUT						
T_{PD-HL}	Propagation delay time, high-to-low	$V_{OD} = 10\text{ mV}$, $C_L = 25\text{ pF}$, $V_{STEP} = 100\text{ mV}$		45		μs
		$V_{OD} = 50\text{ mV}$, $C_L = 25\text{ pF}$, $V_{STEP} = 100\text{ mV}$		16		μs
		$V_{OD} = 100\text{ mV}$, $C_L = 25\text{ pF}$, $V_{STEP} = 200\text{ mV}$		13		μs
T_{PD-LH}	Propagation delay time, low-to-high (Push-Pull output)	$V_{OD} = 10\text{ mV}$, $C_L = 10\text{ pF}$, $V_{STEP} = 100\text{ mV}$		34		μs
T_{PD-LH}	Propagation delay time, low-to-high (Push-Pull output)	$V_{OD} = 50\text{ mV}$, $C_L = 10\text{ pF}$, $V_{STEP} = 100\text{ mV}$		16		μs
T_{PD-LH}	Propagation delay time, low-to-high (Push-Pull output)	$V_{OD} = 100\text{ mV}$, $C_L = 10\text{ pF}$, $V_{STEP} = 200\text{ mV}$		14		μs
T_{PD-LH}	Propagation delay time, low-to-high (Open-Drain output)	$V_{OD} = 10\text{ mV}$, $C_L = 25\text{ pF}$, $R_P = 1\text{ M}\Omega$, $V_{STEP} = 100\text{ mV}$		57		μs
		$V_{OD} = 50\text{ mV}$, $C_L = 25\text{ pF}$, $R_P = 1\text{ M}\Omega$, $V_{STEP} = 100\text{ mV}$		36		μs
		$V_{OD} = 100\text{ mV}$, $C_L = 25\text{ pF}$, $R_P = 1\text{ M}\Omega$, $V_{STEP} = 200\text{ mV}$		35		μs
T_{RISE}	Output Rise Time, 20% to 80%, push-pull output	$C_L = 25\text{ pF}$		0.2		μs
T_{FALL}	Output Fall Time, 80% to 20%	$C_L = 25\text{ pF}$		0.2		μs
POWER ON TIME						
T_{ON}	Power on-time			3		ms

6.7 Typical Characteristics

At $T_A = 25^\circ\text{C}$, $V_S = 12\text{ V}$, $V_{CM} = V_S/2\text{ V}$, $R_P = 1\text{ M}\Omega$ (Open Drain only), $C_L = 25\text{ pF}$, $V_{\text{OVERDRIVE}} = 100\text{ mV}$ unless otherwise noted.

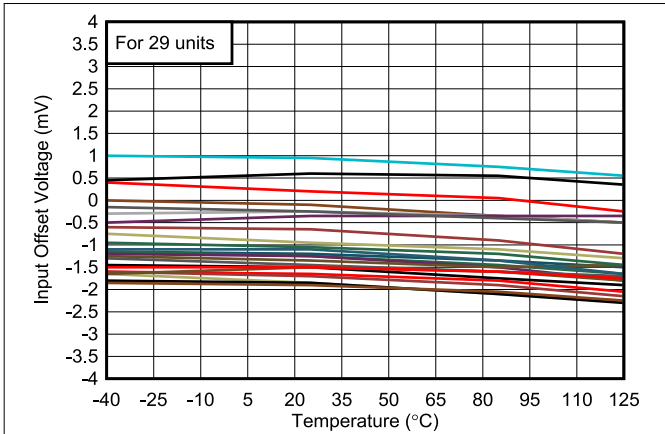

6-1. Offset vs. Temperature

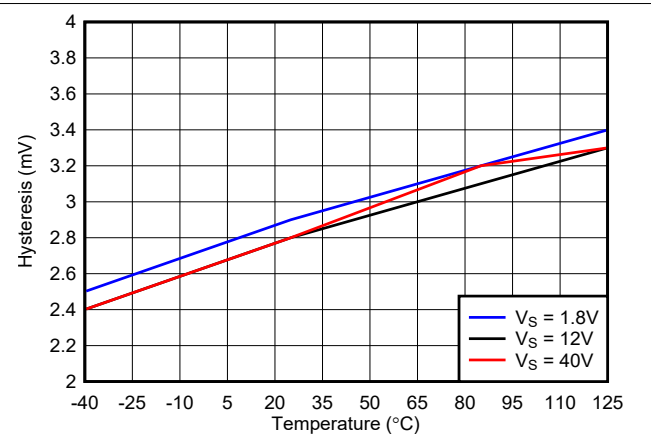

6-2. Hysteresis vs. Temperature

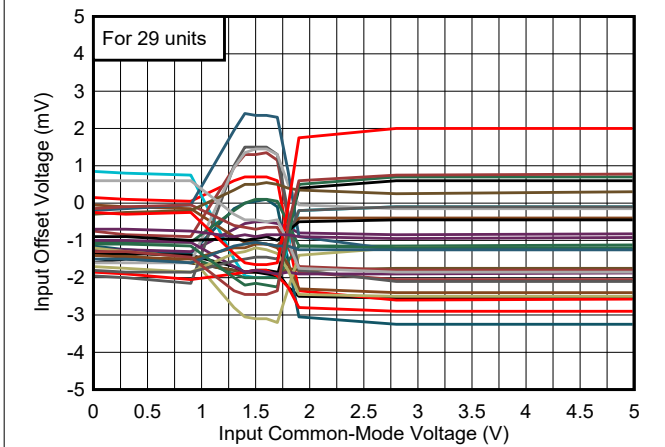

6-3. Offset vs. Common-Mode, 1.8 V

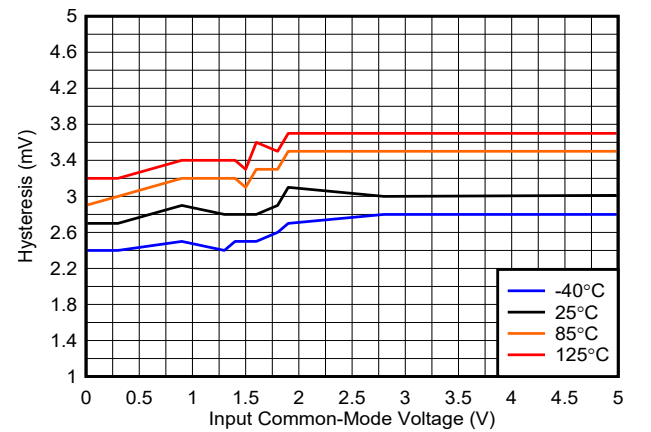

6-4. Hysteresis vs. Common-Mode, 1.8 V

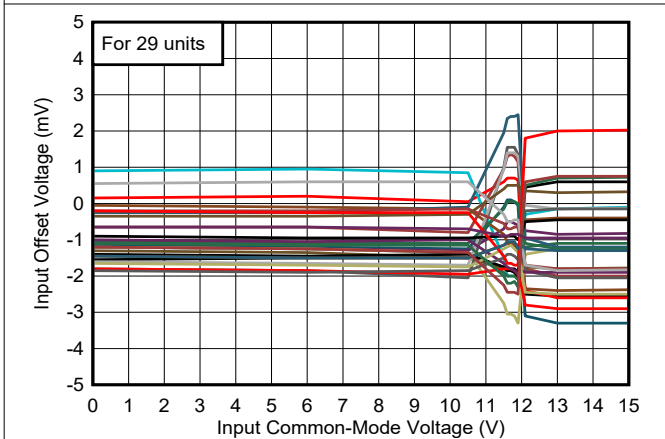

6-5. Offset vs. Common-Mode, 12 V

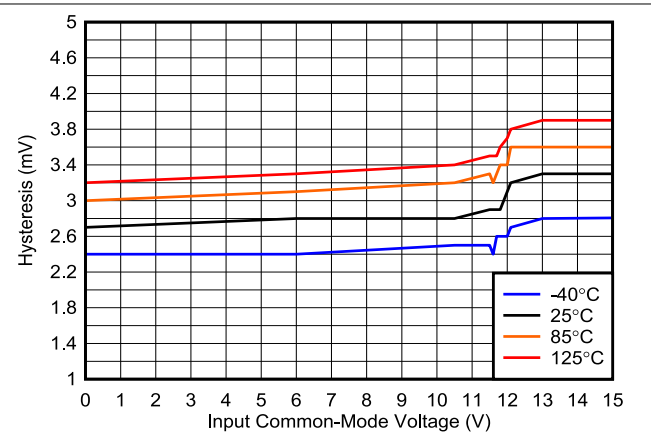

6-6. Hysteresis vs. Common-Mode, 12 V

6.7 Typical Characteristics (continued)

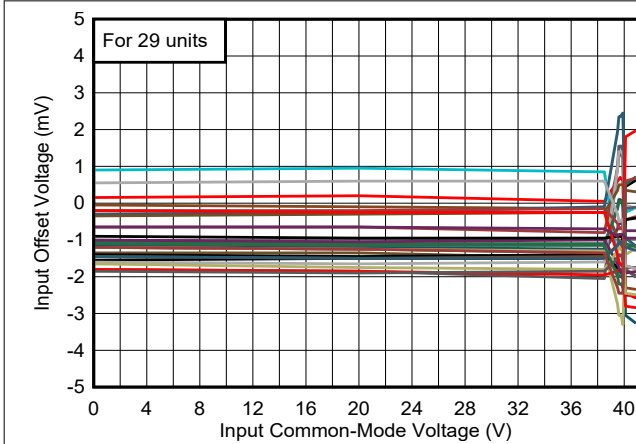

Fig 6-7. Offset vs. Common-Mode, 40 V

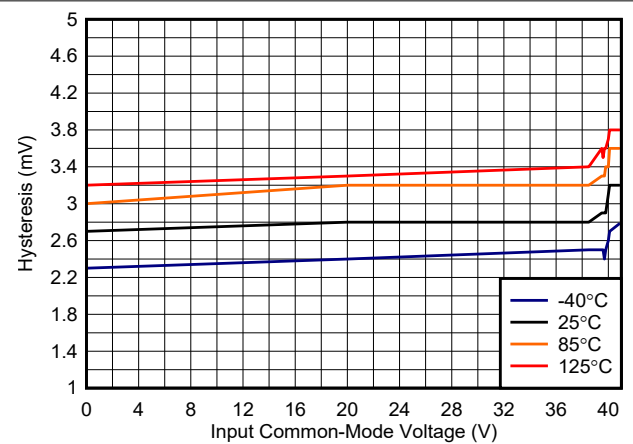

Fig 6-8. Hysteresis vs. Common-Mode, 40 V

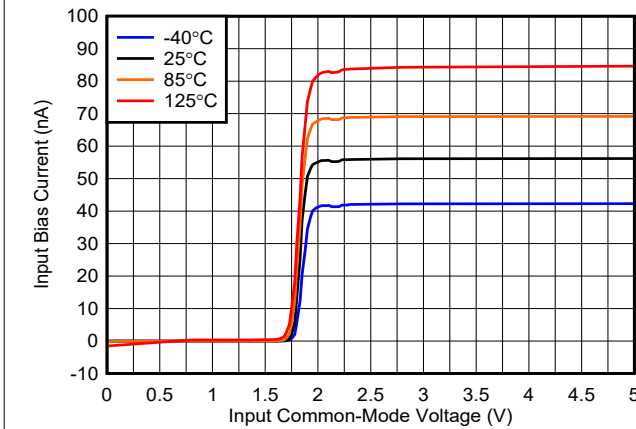

Fig 6-9. Bias Current vs. Common-Mode, 1.8 V

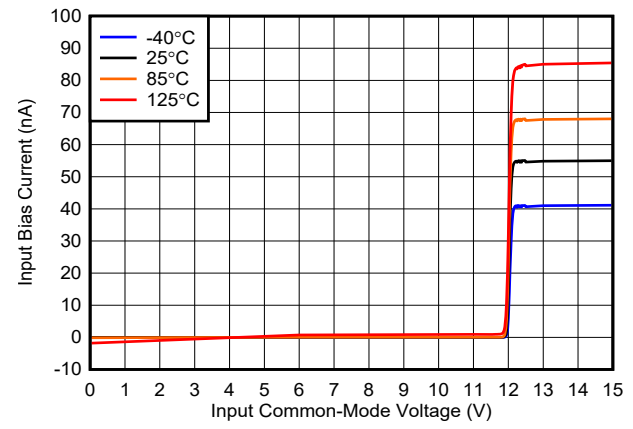

Fig 6-10. Bias Current vs. Common-Mode, 12 V

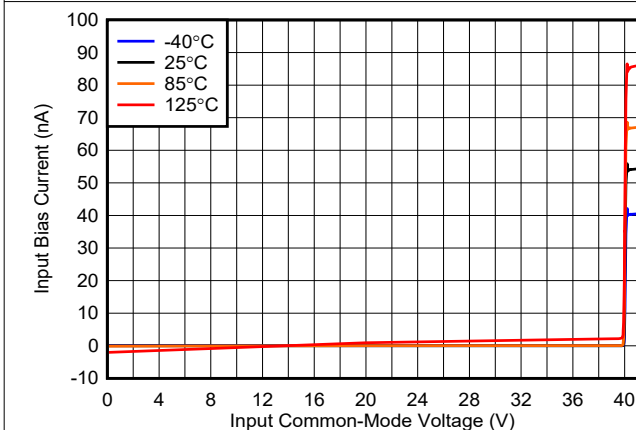

Fig 6-11. Bias Current vs. Common-Mode, 40 V

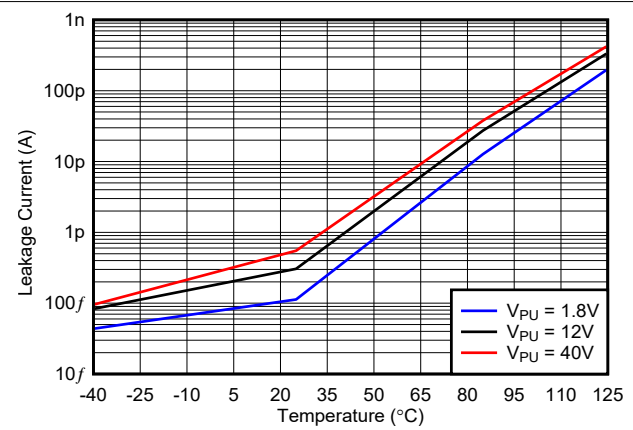
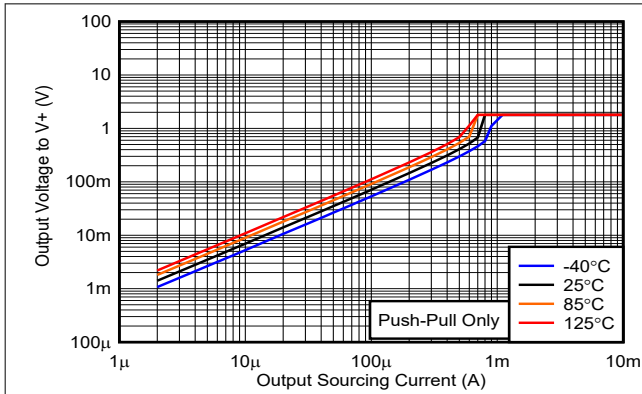
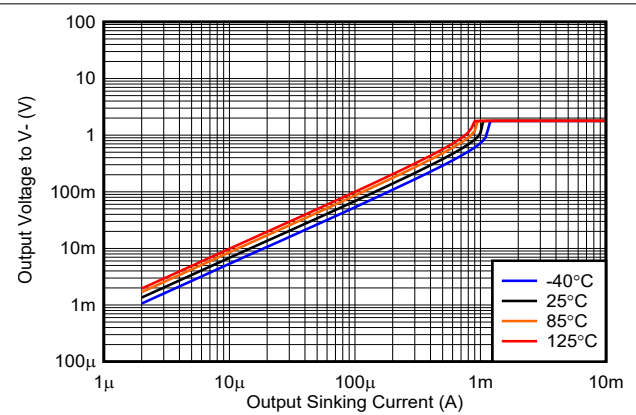

Fig 6-12. Leakage Current vs. Temperature (Open Drain only)

6.7 Typical Characteristics (continued)



6-13. Output Voltage vs. Output Sourcing Current, 1.8V



6-14. Output Voltage vs. Output Sinking Current, 1.8 V

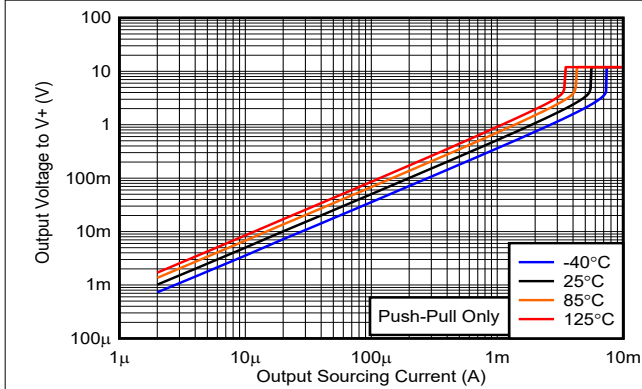

6-15. Output Voltage vs. Output Sourcing Current, 12V

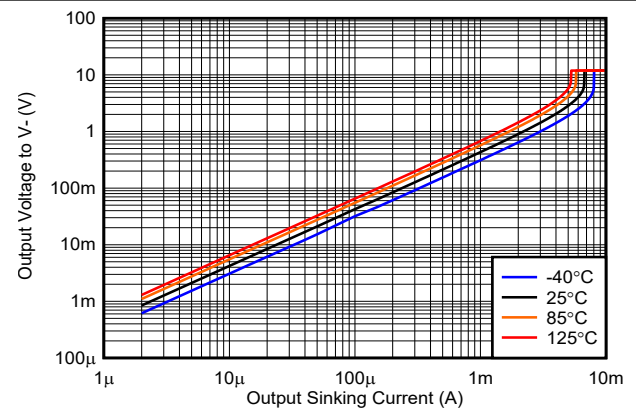

6-16. Output Voltage vs. Output Sinking Current, 12 V

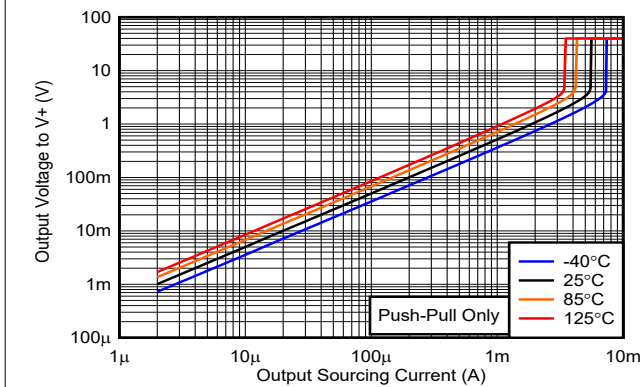

6-17. Output Voltage vs. Output Sourcing Current, 40V

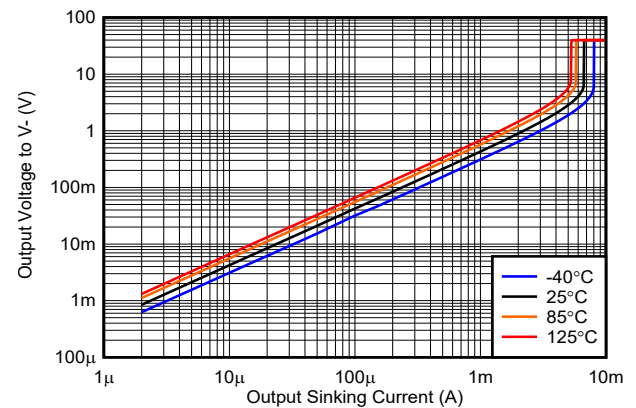

6-18. Output Voltage vs. Output Sinking Current, 40 V

6.7 Typical Characteristics (continued)

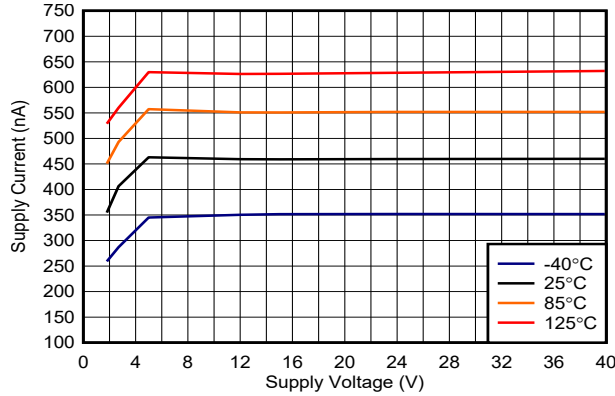

6-19. Supply Current vs. Supply Voltage (Output Low), Push-Pull

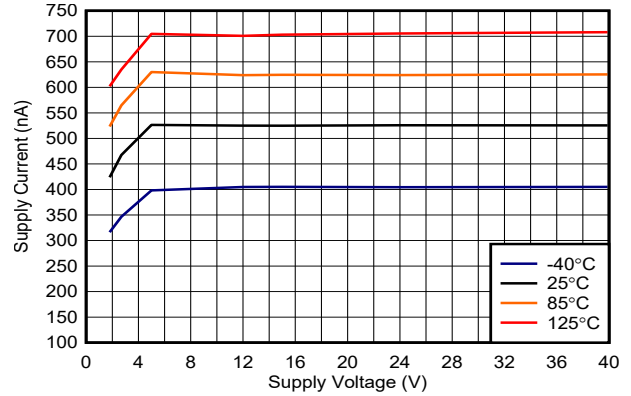

6-20. Supply Current vs. Supply Voltage (Output High), Push-Pull

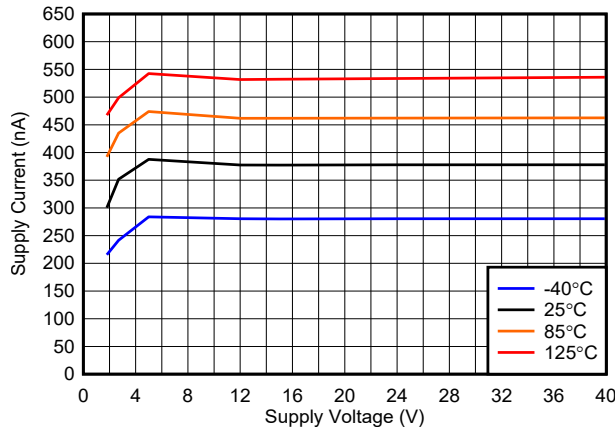

6-21. Supply Current vs. Supply Voltage (Output Low), Open Drain

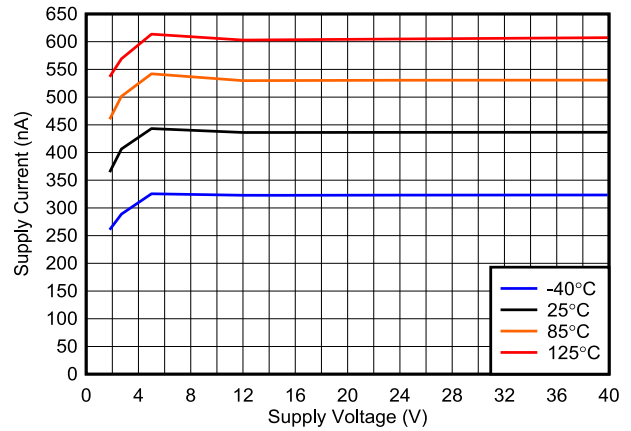

6-22. Supply Current vs. Supply Voltage (Output High), Open Drain

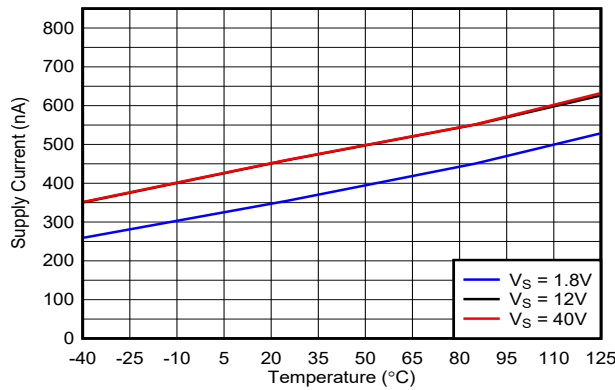

6-23. Supply Current vs. Temperature (Output Low), Push-Pull

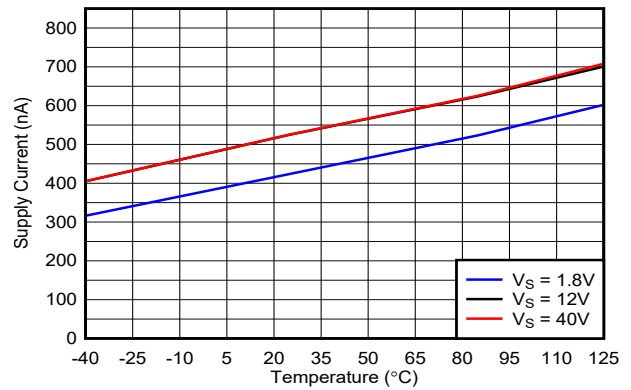

6-24. Supply Current vs. Temperature (Output High), Push-Pull

6.7 Typical Characteristics (continued)

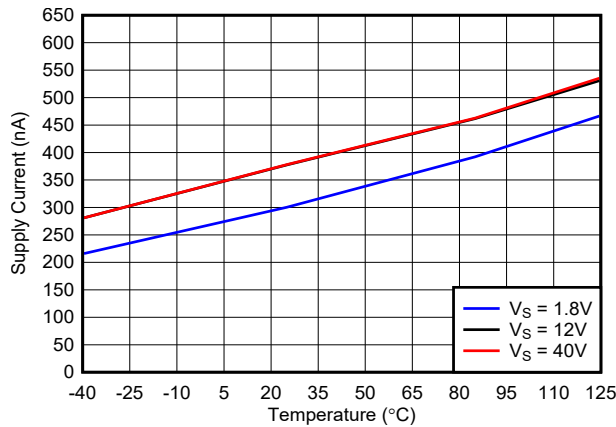

6-25. Supply Current vs. Temperature (Output Low), Open Drain

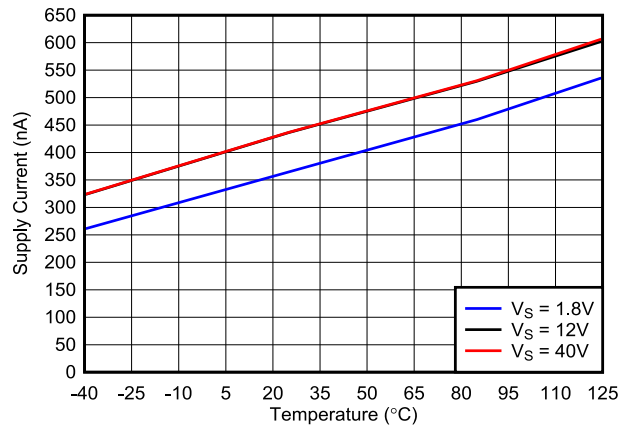

6-26. Supply Current vs. Temperature (Output High), Open Drain

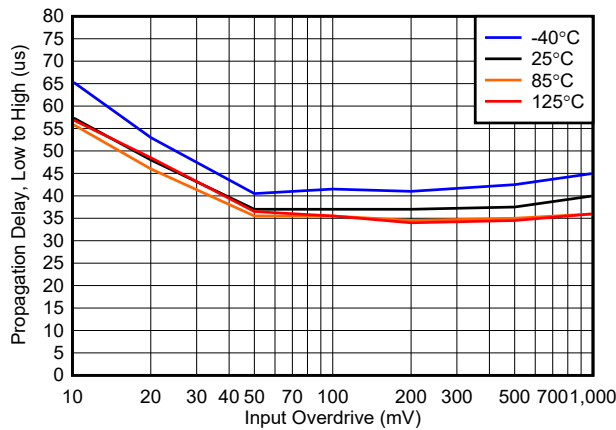

6-27. Propagation Delay, Low to High, 1.8 V, Open Drain

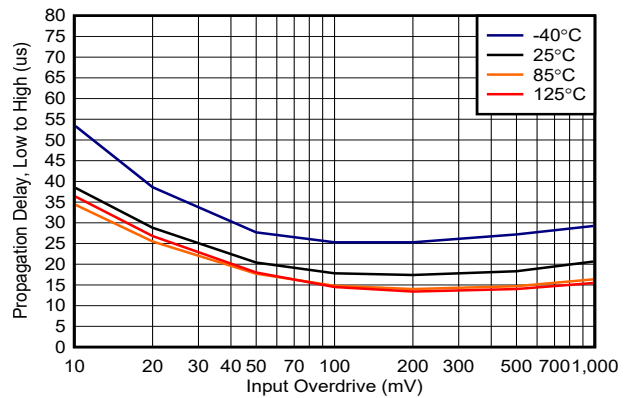

6-28. Propagation Delay, Low to High, 1.8 V, Push-Pull

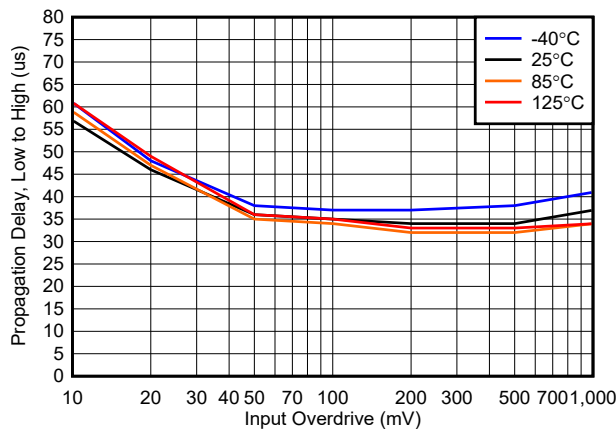

6-29. Propagation Delay, Low to High, 12 V, Open Drain

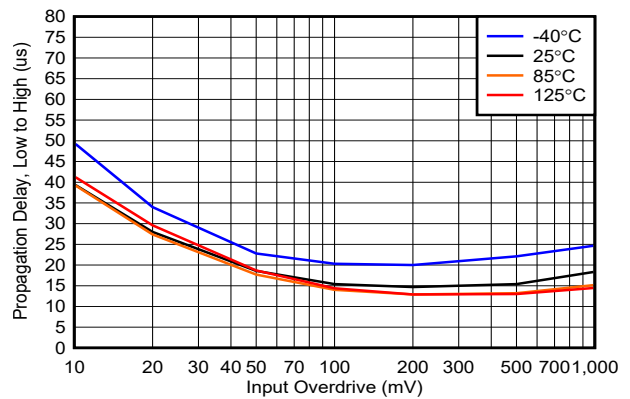

6-30. Propagation Delay, Low to High, 12 V, Push-Pull

6.7 Typical Characteristics (continued)

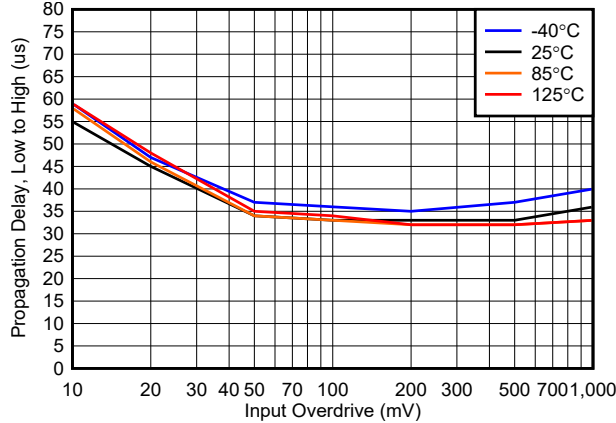

6-31. Propagation Delay, Low to High, 40 V, Open Drain

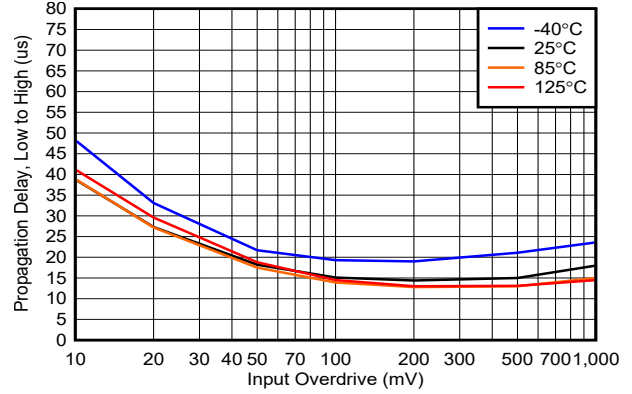

6-32. Propagation Delay, Low to High, 40 V, Push-Pull

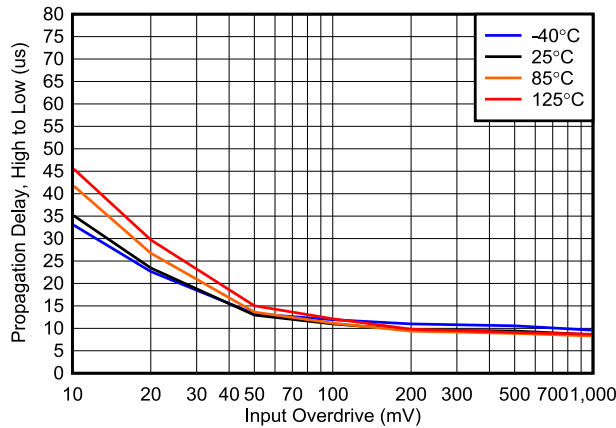

6-33. Propagation Delay, High to Low, 1.8 V

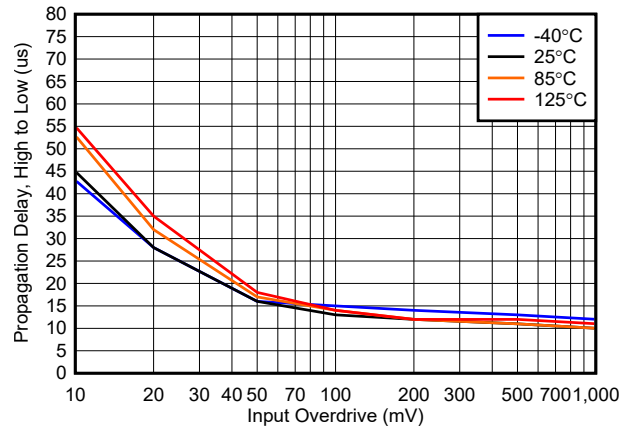

6-34. Propagation Delay, High to Low, 12 V

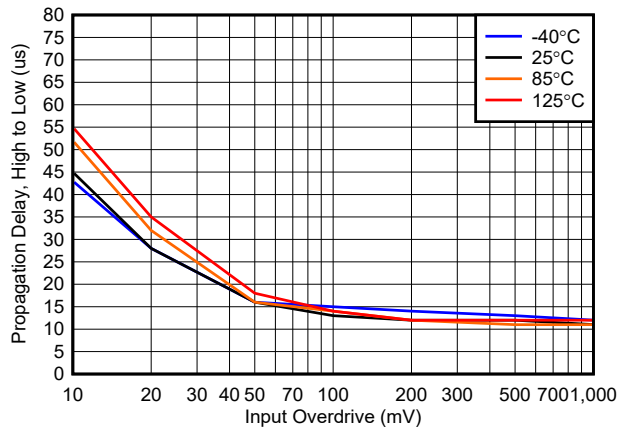

6-35. Propagation Delay, High to Low, 40 V

7 Detailed Description

7.1 Overview

The TLV185x and TLV186x devices are nanopower comparators with push-pull and open-drain output options. Operating down to 1.8 V while only consuming only 440 nA per channel, the TLV185x and TLV186x are well suited for voltage, current, and temperature sensing in low and high voltage low-power, always-on systems. An internal power-on reset circuit ensures that the output remains in a known state during power-up and power-down. Inputs have fail-safe inputs that can tolerate input transients without damage or false outputs.

7.2 Functional Block Diagrams

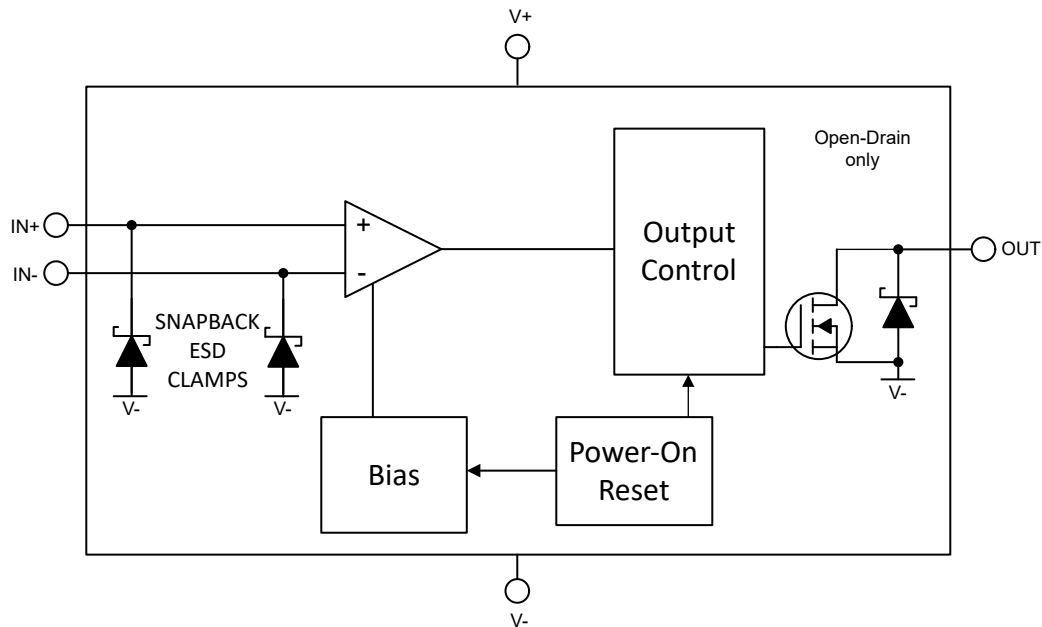

7-1. Block Diagram

7.3 Feature Description

The TLV185x (push-pull output) and TLV186x (open-drain output) devices are nano-power comparators that are capable of operating at high voltages. This family of comparators feature a fail safe input stage and over the rail operating condition mode capable of operating up to 40 V, independent of $V+$. The comparators also have an internal reverse battery protection feature and Power-On-Reset for known start-up conditions.

7.4 Device Functional Modes

7.4.1 Inputs

7.4.1.1 Operating Common-Mode Ranges

The TLV185x and TLV186x devices have two operating common-mode ranges: within-the-rail and over-the-rail.

Within-the-Rail Operation: $IN+$ and $IN-$ are less than ($V+$)

When an input pin is operating less than ($V+$), there are two operating regions defined where input voltages can be compared: low common-mode and high-common mode. In low-common mode which extends typically from 0 V to ($V+$) - 1 V, the typical input bias current is less than 1 pA. In high common-mode which extends typically from ($V+$) - 1 V to ($V+$), the typical input bias current is less than 14 nA.

Over-the-Rail Operation: $IN+$ and/or $IN-$ are greater than ($V+$)

The TLV185x and TLV186x devices have a distinctive input stage that allows the input common mode range to extend from 0 V to 40 V independent of the supply voltage. This feature means that operation at low supply

voltages does not limit the range of input voltages that can be compared. When an input pin is operating over-the-rail (above (V+)), the bias current increases to a typical value of 55 nA.

See Figure 6-9 to 6-11 in the [Typical Characteristics](#) section for input bias current vs. common-mode voltages.

7.4.1.2 Fail-Safe Inputs

A feature of the TLV185x and TLV186x family is that the inputs are fail safe up to 40 V, independent of (V+). The inputs are maintained as high input impedance and can be of any value between -0.1 V and 40 V, even while (V+) is unpowered or below the minimum supply voltage. This feature avoids power sequencing or transient issues since the inputs are not diode clamped to (V+).

7.4.1.3 Unused Inputs

If a channel is not to be used, DO NOT tie the inputs together. Due to the high equivalent bandwidth and low offset voltage, tying the inputs directly together can cause high frequency oscillations as the device triggers on it's own internal wideband noise. Instead, the inputs should be tied to any available voltage that resides within the specified input voltage range and provides a minimum of 50mV differential voltage. For example, one input can be grounded and the other input connected to a reference voltage, or even (V+).

7.4.2 Internal Hysteresis

The device hysteresis transfer curve is shown in [Figure 7-2](#). This curve is a function of three components: V_{TH} , V_{OS} , and V_{HYST} :

- V_{TH} is the actual set voltage or threshold trip voltage.
- V_{OS} is the internal offset voltage between V_{IN+} and V_{IN-} . This voltage is added to V_{TH} to form the actual trip point at which the comparator must respond to change output states.
- V_{HYST} is the internal hysteresis (or trip window) that is designed to reduce comparator sensitivity to noise.

(2.8 mV for the TLV185x/6x family)

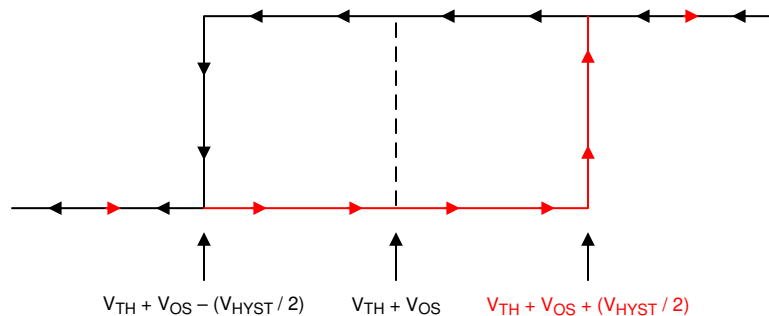

Figure 7-2. Hysteresis Transfer Curve

7.4.3 Outputs

7.4.3.1 TLV185x Push-Pull Output

The TLV185x features a push-pull output stage capable of both sinking and sourcing current. This allows driving loads such as LED's and MOSFET gates, as well as eliminating the need for a power-wasting external pull-up resistor. The push-pull output must never be connected to another output.

Directly shorting the output to the supply rails ((V+) when output "low" or (V-) when output "High") can result in thermal runaway and eventual device destruction at high (>12 V) supply voltages. If output shorts are possible, a series current limiting resistor is recommended to limit the power dissipation.

Unused push-pull outputs should be left floating, and never tied to a supply, ground, or another output.

7.4.3.2 TLV186x Open-Drain Output

The TLV186x features an open-drain (also commonly called open collector) sinking-only output stage enabling the output logic levels to be pulled up to an external voltage from 0 V up to 40 V, independent of the comparator supply voltage (V+). The open-drain output also allows logical OR'ing of multiple open drain outputs and logic

level translation. TI recommends setting the pull-up resistor current to less than 100 μA to optimize V_{OL} logic levels. Lower pull-up resistor values will help increase the rising edge risetime, but at the expense of increasing V_{OL} and higher power dissipation. The risetime will be dependent on the time constant of the total pull-up resistance and total load capacitance. Large value pull-up resistors ($>1\text{ M}\Omega$) will create an exponential rising edge due to the output RC time constant and increase the risetime.

Directly shorting the output to ($V+$) can result in thermal runaway and eventual device destruction at high ($>12\text{ V}$) pull-up voltages. If output shorts are possible, a series current limiting resistor is recommended to limit the power dissipation.

Unused open drain outputs should be left floating, or can be tied to the ($V-$) pin if floating pins are not desired.

7.4.4 ESD Protection

7.4.4.1 Inputs

The fail-safe inputs incorporates internal ESD protection circuits on all pins. The fail-safe inputs have ESD protection from each pin to ($V-$) which allows these pins to exceed the supply voltage ($V+$) up to 40 V. If input voltages are to exceed 40 V, an external clamp would be required. Likewise, negative voltages on the inputs are ESD clamped to ($V-$) and should be limited to less than -0.1 V .

If the inputs are to be connected to a low impedance source, such as a power supply or buffered reference line, TI recommends adding a current-limiting resistor in series with the input to limit any transient currents should the clamps conduct. The current should be limited to 10 mA or less. This series resistance can be part of any resistive input dividers or networks.

7.4.4.2 Outputs

The TLV185x push-pull output protection also contains a conventional diode-type ESD clamps between the output and ($V-$), as the output should not exceed the supply rails.

The TLV186x open-drain output ESD protection also consists of a snapback ESD clamp between the output and ($V-$) to allow the output to be pulled above ($V+$) to a maximum of 40 V.

7.4.5 Power-On Reset (POR)

The TLV185x and TLV186x devices have an internal Power-on-Reset (POR) circuit for known start-up or power-down conditions. While the power supply ($V+$) is ramping up or ramping down, the POR circuitry will be activated for up to 2 ms after the V_{POR} of 1.5 V is crossed. When the supply voltage is equal to or greater than the minimum supply voltage, and after the delay period, the comparator output reflects the state of the differential input (V_{ID}).

For the TLV185x push-pull output devices, the output is held low during the POR period (t_{on}).

For the TLV186x open drain output devices, the POR circuit will keep the output high impedance (Hi-Z) during the POR period (t_{on}).

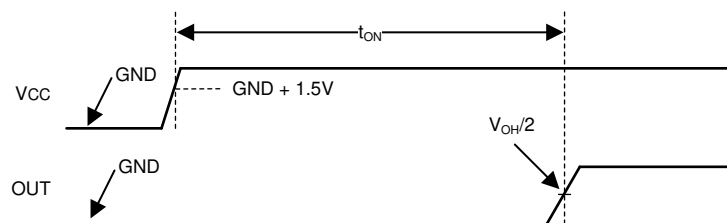

7-3. Power-On Reset Timing Diagram

Note that it the nature of an open collector output that the output will rise with the pull-up voltage during the POR period.

7.4.6 Reverse Battery Protection

The TLV185x and TLV186x devices have an internal reverse battery protection feature that prevents damage to the comparator in the event of improper battery installation to the supply pins. This protection feature works up to 40 V.

8 Application and Implementation

注

Information in the following applications sections is not part of the TI component specification, and TI does not warrant its accuracy or completeness. TI's customers are responsible for determining suitability of components for their purposes. Customers should validate and test their design implementation to confirm system functionality.

8.1 Application Information

8.1.1 Basic Comparator Definitions

8.1.1.1 Operation

The basic comparator compares the input voltage (V_{IN}) on one input to a reference voltage (V_{REF}) on the other input. In the [Figure 8-1](#) example below, if V_{IN} is less than V_{REF} , the output voltage (V_O) is logic low (V_{OL}). If V_{IN} is greater than V_{REF} , the output voltage (V_O) is at logic high (V_{OH}). [Table 8-1](#) summarizes the output conditions. The output logic can be inverted by simply swapping the input pins.

表 8-1. Output Conditions

Inputs Condition	Output
$IN+ > IN-$	HIGH (V_{OH})
$IN+ = IN-$	Indeterminate (chatters - see Hysteresis)
$IN+ < IN-$	LOW (V_{OL})

8.1.1.2 Propagation Delay

There is a delay between from when the input crosses the reference voltage and the output responds. This is called the Propagation Delay. Propagation delay can be different between high-to-low and low-to-high input transitions. This is shown as t_{pLH} and t_{pHL} in [Figure 8-1](#) and is measured from the mid-point of the input to the midpoint of the output.



图 8-1. Comparator Timing Diagram

8.1.1.3 Overdrive Voltage

The overdrive voltage, V_{OD} , is the amount of input voltage beyond the reference voltage (and not the total input peak-to-peak voltage). The overdrive voltage is 100 mV as shown in the [Figure 8-1](#) example. The overdrive voltage can influence the propagation delay (t_p). The smaller the overdrive voltage, the longer the propagation delay, particularly when $<100\text{mV}$. If the fastest speeds are desired, it is recommended to apply the highest amount of overdrive possible.

The risetime (t_r) and falltime (t_f) is the time from the 20% and 80% points of the output waveform.

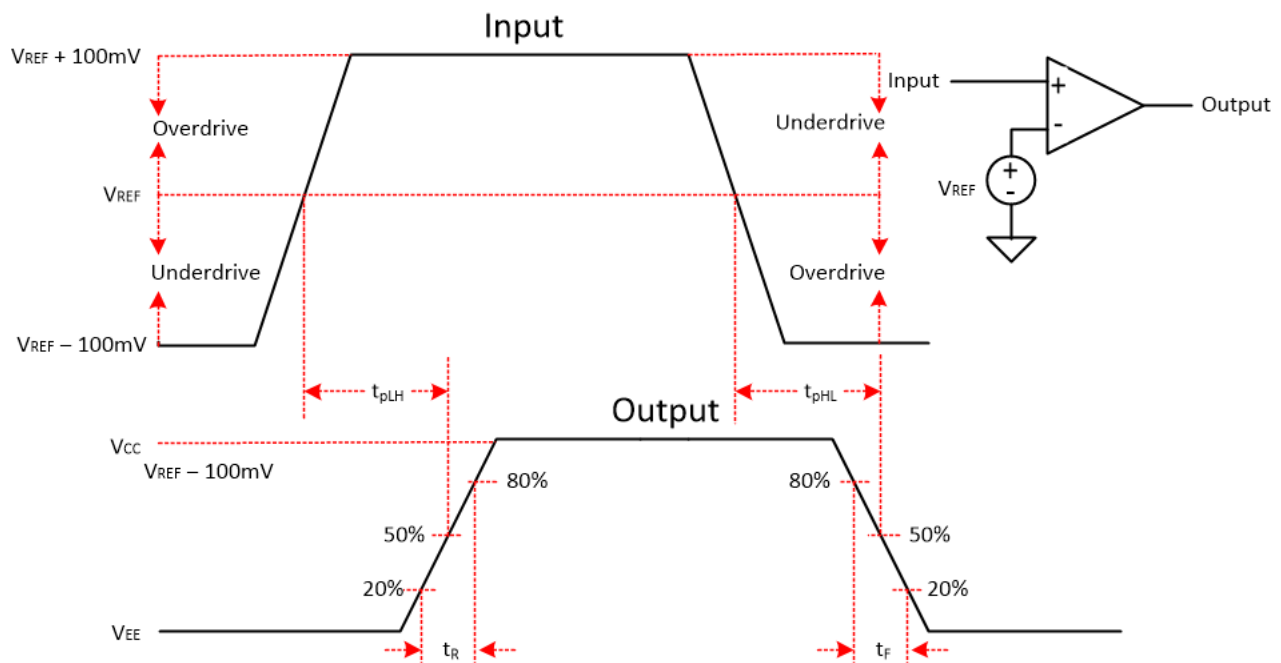
8.1.2 Hysteresis

The basic comparator configuration may produce a noisy "chatter" output if the applied differential input voltage is near the comparator's offset voltage. This usually occurs when the input signal is moving very slowly across the switching threshold of the comparator. This problem can be prevented by adding external hysteresis to the comparator.

Since the TLV185x and TLV186x devices only have a minimal amount of internal hysteresis of 2.7 mV, external hysteresis can be applied in the form of a positive feedback loop that adjusts the trip point of the comparator depending on its current output state.

The hysteresis transfer curve is shown in [Figure 8-2](#). This curve is a function of three components: V_{TH} , V_{OS} , and V_{HYST} :

- V_{TH} is the actual set voltage or threshold trip voltage.
- V_{OS} is the internal offset voltage between V_{IN+} and V_{IN-} . This voltage is added to V_{TH} to form the actual trip point at which the comparator must respond to change output states.
- V_{HYST} is the hysteresis (or trip window) that is designed to reduce comparator sensitivity to noise.

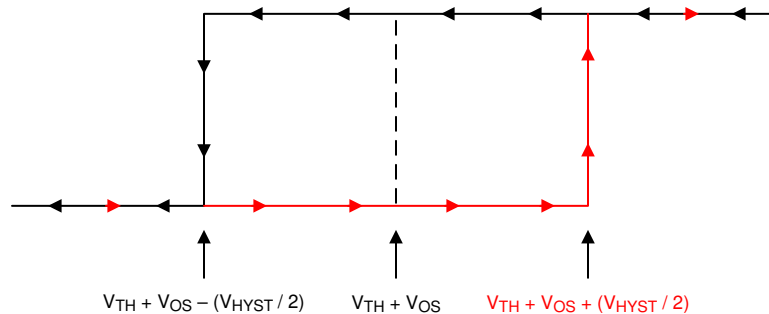

Figure 8-2. Hysteresis Transfer Curve

For more information, please see Application Note SBOA219 "[Comparator with and without hysteresis circuit](#)".

8.1.2.1 Inverting Comparator With Hysteresis

The inverting comparator with hysteresis requires a three-resistor network that is referenced to the comparator supply voltage (V_{CC}), as shown in [Figure 8-3](#).



图 8-3. TLV185x 在具有迟滞的倒相配置中

当输出为高和低时的等效电阻网络如图 8-3 所示。

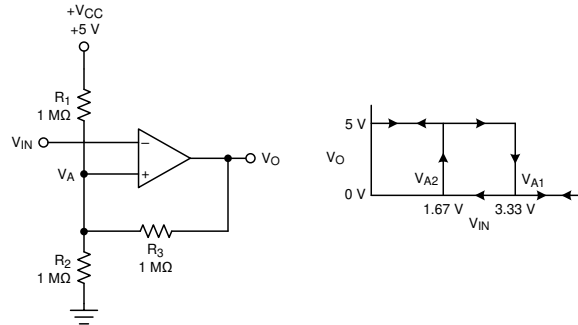

图 8-4. 倒相配置电阻等效网络

当 V_{IN} 小于 V_A 时，输出电压为高（为简化起见，假设 V_O 切换为 V_{CC} ）。三个网络电阻可以表示为 $R1 \parallel R3$ 与 $R2$ 串联，如图 8-4 所示。

式 1 定义了高到低的翻转电压 (V_{A1})。

$$V_{A1} = V_{CC} \times \frac{R2}{(R1 \parallel R3) + R2} \tag{1}$$

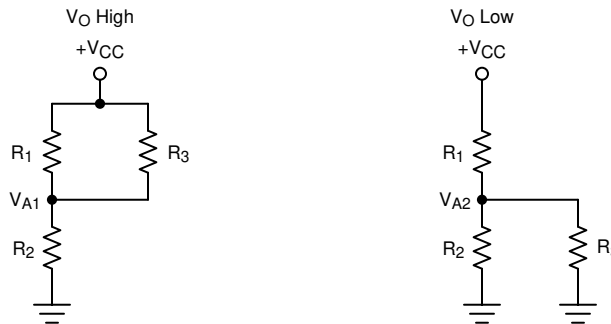
当 V_{IN} 大于 V_A 时，输出电压为低。在这种情况下，三个网络电阻可以表示为 $R2 \parallel R3$ 与 $R1$ 串联，如图 2 所示。

使用式 2 来定义低到高的翻转电压 (V_{A2})。

$$V_{A2} = V_{CC} \times \frac{R2 \parallel R3}{R1 + (R2 \parallel R3)} \tag{2}$$

式 3 定义了网络提供的总迟滞。

$$\Delta V_A = V_{A1} - V_{A2} \tag{3}$$

8.1.2.2 非倒相比较器具有迟滞

非倒相比较器具有迟滞需要两个电阻网络和一个电压参考 (V_{REF}) 在倒相输入，如图 8-5 所示，

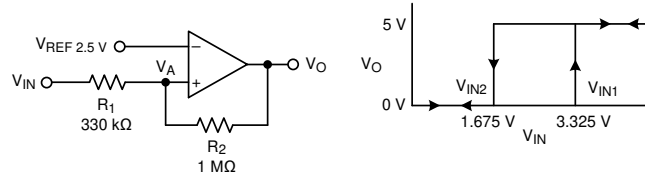

Figure 8-5. TLV185x in a Non-Inverting Configuration With Hysteresis

The equivalent resistor networks when the output is high and low are shown in [Figure 8-6](#).

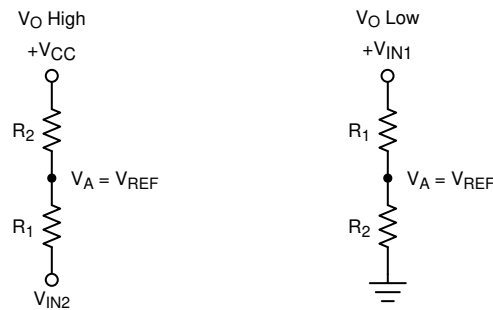

Figure 8-6. Non-Inverting Configuration Resistor Networks

When V_{IN} is less than V_{REF} , the output is low. For the output to switch from low to high, V_{IN} must rise above the V_{IN1} threshold. Use [Equation 4](#) to calculate V_{IN1} .

$$V_{IN1} = R1 \times \frac{V_{REF}}{R2} + V_{REF} \quad (4)$$

When V_{IN} is greater than V_{REF} , the output is high. For the comparator to switch back to a low state, V_{IN} must drop below V_{IN2} . Use [Equation 5](#) to calculate V_{IN2} .

$$V_{IN2} = \frac{V_{REF} (R1 + R2) - V_{CC} \times R1}{R2} \quad (5)$$

The hysteresis of this circuit is the difference between V_{IN1} and V_{IN2} , as shown in [Equation 6](#).

$$\Delta V_{IN} = V_{CC} \times \frac{R1}{R2} \quad (6)$$

For more information, please see Application Notes SNOA997 "Inverting comparator with hysteresis circuit" and SBOA313 "Non-Inverting Comparator With Hysteresis Circuit".

8.1.2.3 Inverting and Non-Inverting Hysteresis using Open-Drain Output

It is also possible to use an open drain output device, such as the TLV186x, but the output pull-up resistor must also be taken into account in the calculations. The pull-up resistor is seen in series with the feedback resistor when the output is high. Thus, the feedback resistor is actually seen as $R2 + R_{PULLUP}$. TI recommends that the pull-up resistor be at least 10 times less than the feedback resistor value.

8.2 Typical Applications

8.2.1 Window Comparator

Window comparators are commonly used to detect undervoltage and overvoltage conditions. [Figure 8-7](#) shows a simple window comparator circuit. Window comparators require open drain outputs (TLV186x if the outputs are directly connected together).

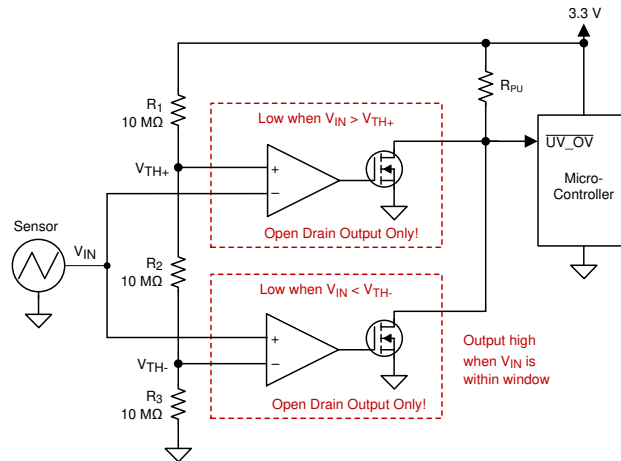

8-7. Window Comparator

8.2.1.1 Design Requirements

For this design, follow these design requirements:

- Alert (logic low output) when an input signal is less than 1.1 V
- Alert (logic low output) when an input signal is greater than 2.2 V
- Alert signal is active low
- Operate from a 3.3-V power supply

8.2.1.2 Detailed Design Procedure

Configure the circuit as shown in [8-7](#). Connect $V+$ to a 3.3-V power supply and V_{EE} to ground. Make R_1 , R_2 and R_3 each 10-M Ω resistors. These three resistors are used to create the positive and negative thresholds for the window comparator (V_{TH+} and V_{TH-}).

With each resistor being equal, V_{TH+} is 2.2 V and V_{TH-} is 1.1 V. Large resistor values such as 10-M Ω are used to minimize power consumption. The resistor values may be recalculated to provide the desired trip point values.

The sensor output voltage is applied to the inverting and noninverting inputs of the two comparators. Using two open-drain output comparators allows the two comparator outputs to be Wire-OR'ed together.

The respective comparator outputs will be low when the sensor is less than 1.1 V or greater than 2.2 V. The respective comparator outputs will be high when the sensor is in the range of 1.1 V to 2.2 V (within the "window"), as shown in [8-8](#).

8.2.1.3 Application Curve

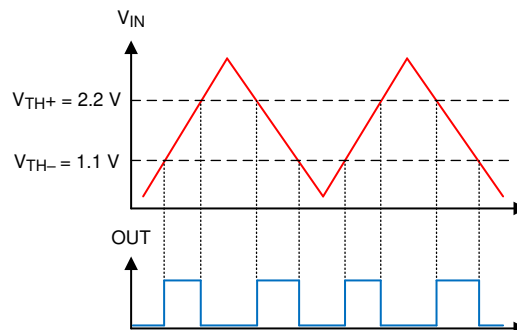

8-8. Window Comparator Results

For more information, please see Application note SBOA221 "[Window comparator circuit](#)".

8.2.2 Undervoltage Detection

Undervoltage detection is frequently required in low-power, always-on systems to alert the downstream device that a battery or supply voltage has drooped below the nominal voltage level. The TLV185x and TLV186x devices have an over-the-rail capability which allows the comparator to monitor high voltages up to 40 V on the inputs while operating at lower supply voltages such as 3.3 V, as shown in [Figure 8-9](#). The high voltage battery V_{BAT} is divided down to be compared against a reference voltage, which can be set by a shunt regulator such as the TL431. When the voltage on the non-inverting input drops below the reference voltage, then the output of the comparator will toggle and send an alert signal to a MCU.

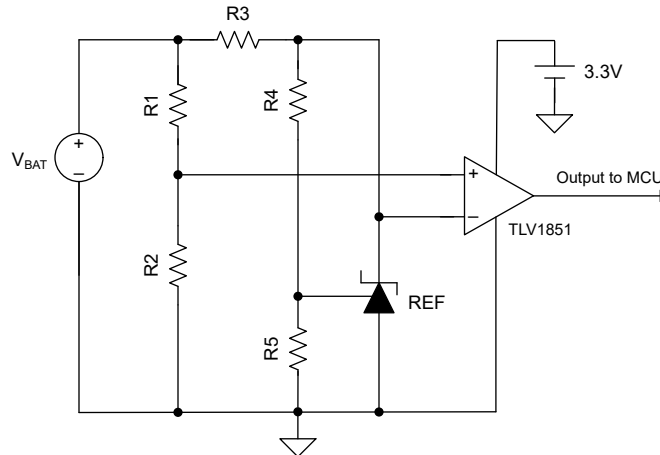

Figure 8-9. Undervoltage Detection

8.2.3 Reverse Battery and Overvoltage Protection Scheme

In battery powered applications, it is essential to have safeguards in place to protect the internal electronics against reverse battery connections. [Figure 8-10](#) shows a protection scheme using TLV1851 to prevent damage to the overall system in the events of both improper battery installation and overvoltage conditions. Under either of these instances, Q1 and Q2 will open, thus protecting the system from ever seeing reverse battery or overvoltage conditions.

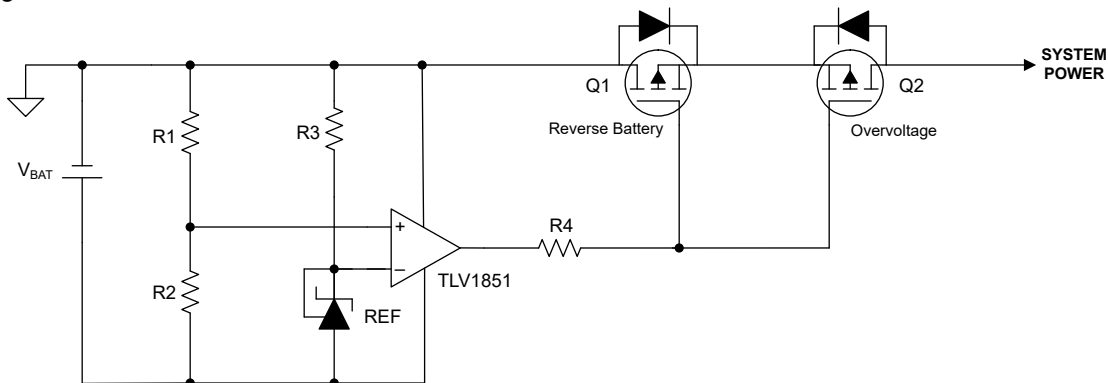

Figure 8-10. Reverse Battery and Overvoltage Protection Scheme

8.3 Power Supply Recommendations

Due to the fast output edges, it is critical to have bypass capacitors on the supply pin to prevent supply ringing and false triggers and oscillations. Bypass the supply directly at *each* device with a low ESR 0.1 μF ceramic bypass capacitor directly between the (V+) pin and ground pins. Narrow peak currents will be drawn during the output transition time, particularly for the push-pull output device. These narrow pulses can cause un-bypassed supply lines and poor grounds to ring, possibly causing variation that can eat into the input voltage range and create an inaccurate comparison or even oscillations.

The device may be powered from both "split" supplies ((V+) &(V-)), or "single" supplies ((V+) and GND), with GND applied to the (V-) pin. Input signals must stay within the recommended input range for either type. Note that with a "split" supply the output will now swing "low" (V_{OL}) to (V-) potential and not GND.

9 Layout

9.1 Layout Guidelines

For accurate comparator applications it is important maintain a stable power supply with minimized noise and glitches. Output rise and fall times are in the tens of nanoseconds, and should be treated as high speed logic devices. The bypass capacitor should be as close to the supply pin as possible and connected to a solid ground plane, and preferably directly between the (V+) and GND pins.

Minimize coupling between outputs and inputs to prevent output oscillations. Do not run output and input traces in parallel unless there is a (V+) or GND trace between output to reduce coupling. When series resistance is added to inputs, place resistor close to the device. A low value (<100 ohms) resistor may also be added in series with the output to dampen any ringing or reflections on long, non-impedance controlled traces. For best edge shapes, controlled impedance traces with back-terminations should be used when routing long distances.

9.2 Layout Example

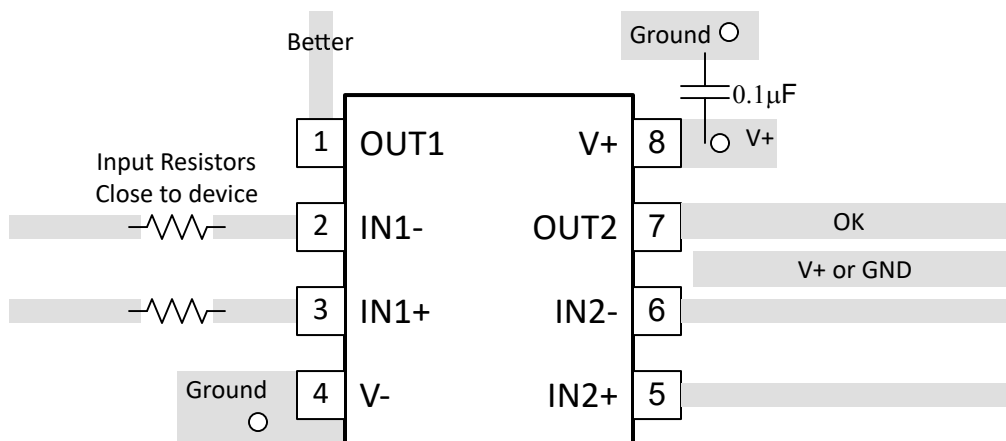

9-1. Dual Layout Example

10 デバイスおよびドキュメントのサポート

10.1 Documentation Support

10.1.1 Related Documentation

[Analog Engineers Circuit Cookbook: Amplifiers \(See Comparators section\) - SLYY137](#)

[Precision Design, Comparator with Hysteresis Reference Design— TIDU020](#)

[Window comparator circuit - SBOA221](#)

[Reference Design, Window Comparator Reference Design— TIPD178](#)

[Comparator with and without hysteresis circuit - SBOA219](#)

[Inverting comparator with hysteresis circuit - SNOA997](#)

[Non-Inverting Comparator With Hysteresis Circuit - SBOA313](#)

[A Quad of Independently Func Comparators - SNOA654](#)

10.2 ドキュメントの更新通知を受け取る方法

ドキュメントの更新についての通知を受け取るには、ti.com のデバイス製品フォルダを開いてください。「更新の通知を受け取る」をクリックして登録すると、変更されたすべての製品情報に関するダイジェストを毎週受け取れます。変更の詳細については、修正されたドキュメントに含まれている改訂履歴をご覧ください。

10.3 サポート・リソース

[TI E2E™ サポート・フォーラム](#)は、エンジニアが検証済みの回答と設計に関するヒントをエキスパートから迅速かつ直接得ることができる場所です。既存の回答を検索したり、独自の質問をしたりすることで、設計に必要な支援を迅速に得ることができます。

リンクされているコンテンツは、該当する貢献者により、現状のまま提供されるものです。これらは TI の仕様を構成するものではなく、必ずしも TI の見解を反映したものではありません。TI の[使用条件](#)を参照してください。

10.4 Trademarks

TI E2E™ is a trademark of Texas Instruments.

すべての商標は、それぞれの所有者に帰属します。

10.5 静電気放電に関する注意事項



この IC は、ESD によって破損する可能性があります。テキサス・インスツルメンツは、IC を取り扱う際には常に適切な注意を払うことを推奨します。正しい取り扱いおよび設置手順に従わない場合、デバイスを破損するおそれがあります。

ESD による破損は、わずかな性能低下からデバイスの完全な故障まで多岐にわたります。精密な IC の場合、パラメータがわずかに変化するだけで公表されている仕様から外れる可能性があるため、破損が発生しやすくなっています。

10.6 用語集

[テキサス・インスツルメンツ用語集](#) この用語集には、用語や略語の一覧および定義が記載されています。

11 Mechanical, Packaging, and Orderable Information

The following pages include mechanical, packaging, and orderable information. This information is the most current data available for the designated devices. This data is subject to change without notice and revision of this document. For browser-based versions of this data sheet, refer to the left-hand navigation.

PACKAGING INFORMATION

Orderable Device	Status (1)	Package Type	Package Drawing	Pins	Package Qty	Eco Plan (2)	Lead finish/ Ball material (6)	MSL Peak Temp (3)	Op Temp (°C)	Device Marking (4/5)	Samples
TLV1851DBVR	ACTIVE	SOT-23	DBV	5	3000	RoHS & Green	NIPDAU	Level-1-260C-UNLIM	-40 to 125	1851	Samples
TLV1861DBVR	ACTIVE	SOT-23	DBV	5	3000	RoHS & Green	NIPDAU	Level-1-260C-UNLIM	-40 to 125	1861	Samples

(1) The marketing status values are defined as follows:

ACTIVE: Product device recommended for new designs.

LIFEBUY: TI has announced that the device will be discontinued, and a lifetime-buy period is in effect.

NRND: Not recommended for new designs. Device is in production to support existing customers, but TI does not recommend using this part in a new design.

PREVIEW: Device has been announced but is not in production. Samples may or may not be available.

OBSOLETE: TI has discontinued the production of the device.

(2) **RoHS:** TI defines "RoHS" to mean semiconductor products that are compliant with the current EU RoHS requirements for all 10 RoHS substances, including the requirement that RoHS substance do not exceed 0.1% by weight in homogeneous materials. Where designed to be soldered at high temperatures, "RoHS" products are suitable for use in specified lead-free processes. TI may reference these types of products as "Pb-Free".

RoHS Exempt: TI defines "RoHS Exempt" to mean products that contain lead but are compliant with EU RoHS pursuant to a specific EU RoHS exemption.

Green: TI defines "Green" to mean the content of Chlorine (Cl) and Bromine (Br) based flame retardants meet JS709B low halogen requirements of <=1000ppm threshold. Antimony trioxide based flame retardants must also meet the <=1000ppm threshold requirement.

(3) MSL, Peak Temp. - The Moisture Sensitivity Level rating according to the JEDEC industry standard classifications, and peak solder temperature.

(4) There may be additional marking, which relates to the logo, the lot trace code information, or the environmental category on the device.

(5) Multiple Device Markings will be inside parentheses. Only one Device Marking contained in parentheses and separated by a "~" will appear on a device. If a line is indented then it is a continuation of the previous line and the two combined represent the entire Device Marking for that device.

(6) Lead finish/Ball material - Orderable Devices may have multiple material finish options. Finish options are separated by a vertical ruled line. Lead finish/Ball material values may wrap to two lines if the finish value exceeds the maximum column width.

Important Information and Disclaimer:The information provided on this page represents TI's knowledge and belief as of the date that it is provided. TI bases its knowledge and belief on information provided by third parties, and makes no representation or warranty as to the accuracy of such information. Efforts are underway to better integrate information from third parties. TI has taken and continues to take reasonable steps to provide representative and accurate information but may not have conducted destructive testing or chemical analysis on incoming materials and chemicals. TI and TI suppliers consider certain information to be proprietary, and thus CAS numbers and other limited information may not be available for release.

In no event shall TI's liability arising out of such information exceed the total purchase price of the TI part(s) at issue in this document sold by TI to Customer on an annual basis.

OTHER QUALIFIED VERSIONS OF TLV1851, TLV1861 :

- Automotive : [TLV1851-Q1](#), [TLV1861-Q1](#)

NOTE: Qualified Version Definitions:

- Automotive - Q100 devices qualified for high-reliability automotive applications targeting zero defects

DBV0005A



PACKAGE OUTLINE

SOT-23 - 1.45 mm max height

SMALL OUTLINE TRANSISTOR

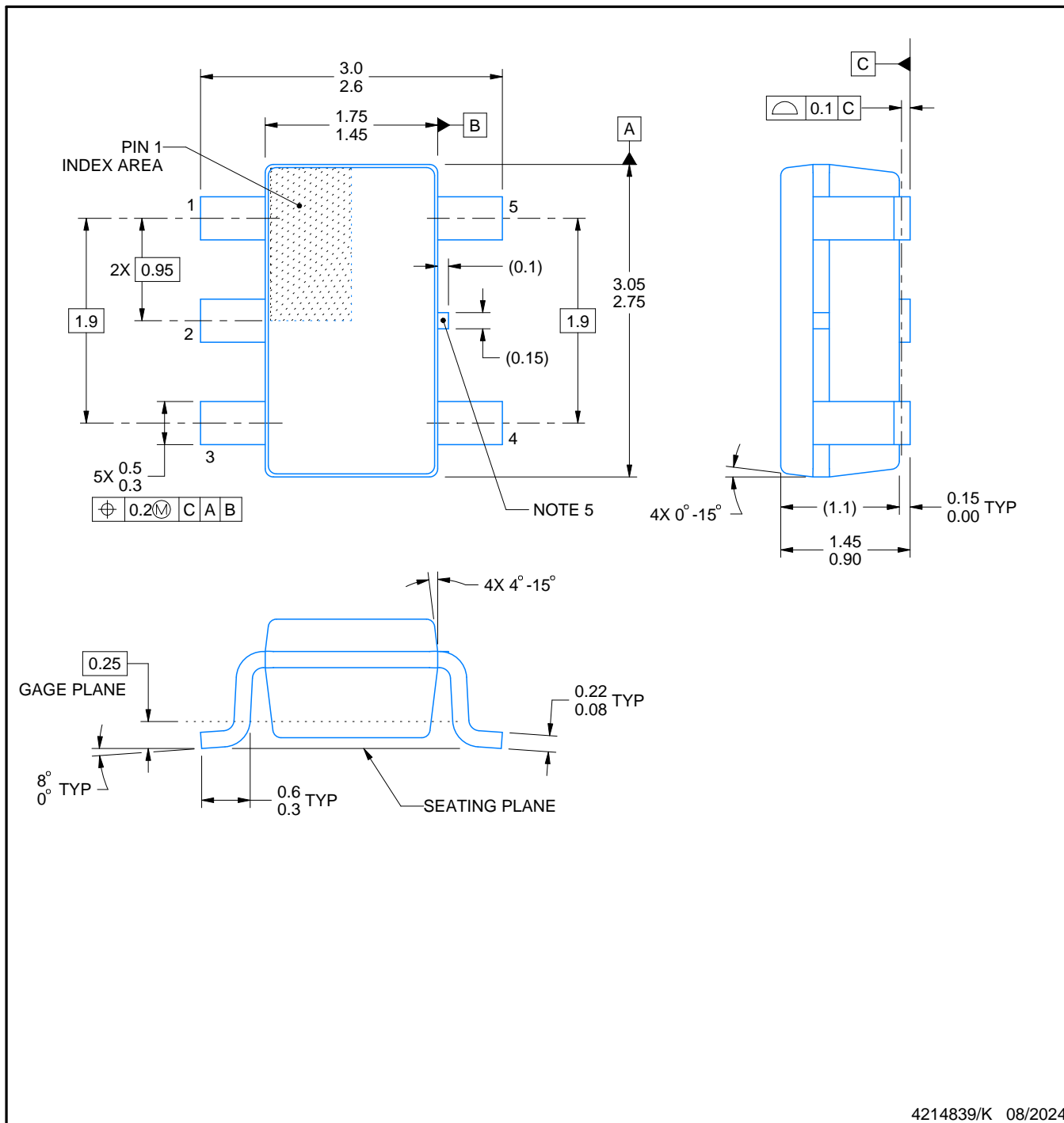

4214839/K 08/2024

NOTES:

1. All linear dimensions are in millimeters. Any dimensions in parenthesis are for reference only. Dimensioning and tolerancing per ASME Y14.5M.
2. This drawing is subject to change without notice.
3. Reference JEDEC MO-178.
4. Body dimensions do not include mold flash, protrusions, or gate burrs. Mold flash, protrusions, or gate burrs shall not exceed 0.25 mm per side.
5. Support pin may differ or may not be present.

EXAMPLE BOARD LAYOUT

DBV0005A

SOT-23 - 1.45 mm max height

SMALL OUTLINE TRANSISTOR



LAND PATTERN EXAMPLE
EXPOSED METAL SHOWN
SCALE:15X



SOLDER MASK DETAILS

4214839/K 08/2024

NOTES: (continued)

- 6. Publication IPC-7351 may have alternate designs.
- 7. Solder mask tolerances between and around signal pads can vary based on board fabrication site.

EXAMPLE STENCIL DESIGN

DBV0005A

SOT-23 - 1.45 mm max height

SMALL OUTLINE TRANSISTOR



SOLDER PASTE EXAMPLE
BASED ON 0.125 mm THICK STENCIL
SCALE:15X

4214839/K 08/2024

NOTES: (continued)

8. Laser cutting apertures with trapezoidal walls and rounded corners may offer better paste release. IPC-7525 may have alternate design recommendations.
9. Board assembly site may have different recommendations for stencil design.

重要なお知らせと免責事項

TI は、技術データと信頼性データ (データシートを含みます)、設計リソース (リファレンス・デザインを含みます)、アプリケーションや設計に関する各種アドバイス、Web ツール、安全性情報、その他のリソースを、欠陥が存在する可能性のある「現状のまま」提供しており、商品性および特定目的に対する適合性の黙示保証、第三者の知的財産権の非侵害保証を含むいかなる保証も、明示的または黙示的にかかわらず拒否します。

これらのリソースは、TI 製品を使用する設計の経験を積んだ開発者への提供を意図したものです。(1) お客様のアプリケーションに適した TI 製品の選定、(2) お客様のアプリケーションの設計、検証、試験、(3) お客様のアプリケーションに該当する各種規格や、その他のあらゆる安全性、セキュリティ、規制、または他の要件への確実な適合に関する責任を、お客様のみが単独で負うものとし、

上記の各種リソースは、予告なく変更される可能性があります。これらのリソースは、リソースで説明されている TI 製品を使用するアプリケーションの開発の目的でのみ、TI はその使用をお客様に許諾します。これらのリソースに関して、他の目的で複製することや掲載することは禁止されています。TI や第三者の知的財産権のライセンスが付与されている訳ではありません。お客様は、これらのリソースを自身で使用した結果発生するあらゆる申し立て、損害、費用、損失、責任について、TI およびその代理人を完全に補償するものとし、TI は一切の責任を拒否します。

TI の製品は、[TI の販売条件](#)、または [ti.com](#) やかかる TI 製品の関連資料などのいずれかを通じて提供する適用可能な条項の下で提供されています。TI がこれらのリソースを提供することは、適用される TI の保証または他の保証の放棄の拡大や変更を意味するものではありません。

お客様がいかなる追加条項または代替条項を提案した場合でも、TI はそれらに異議を唱え、拒否します。

郵送先住所 : Texas Instruments, Post Office Box 655303, Dallas, Texas 75265
Copyright © 2024, Texas Instruments Incorporated