

TLV6703-Q1 400mV 基準電圧搭載の車載用マイクロパワー、18V コンパレータ

1 特長

- 車載アプリケーションに対応
- 下記内容で AEC-Q100 認定済み:
 - デバイス温度グレード 1: -40°C ~ +125°C の動作時 周囲温度範囲
 - デバイス HBM ESD 分類レベル H2
 - デバイス CDM ESD 分類レベル C6
- 広い電源電圧範囲: 1.8V ~ 18V
- スレッシュホールドを変更可能: 最低 400mV
- スレッシュホールドの高い精度
 - 25°C で最大 0.5%
 - 温度範囲全体で最大 1.0%
- 低い静止電流: 5.5µA (標準値)
- オープン・ドレイン出力
- 内部ヒステリシス: 5.5mV (標準値)
- 温度範囲: -40°C ~ +125°C
- パッケージ: リードレス WSON-6

2 アプリケーション

- 緊急通話 (eCall)
- 車載用ヘッド・ユニット
- インストルメント・クラスタ
- オンボード・チャージャ (OBC) / ワイヤレス・チャージャ

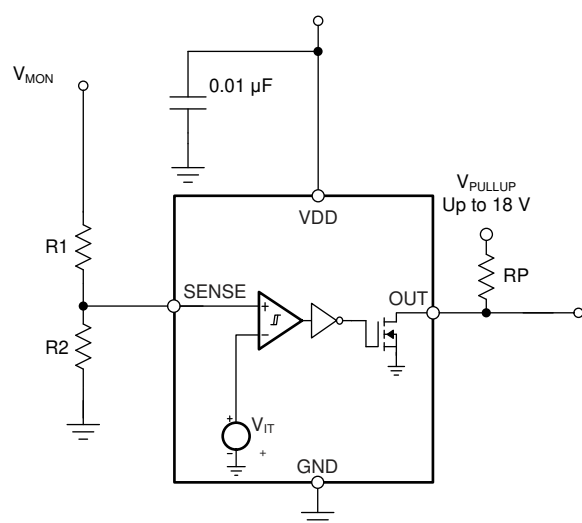

ブロック概略図

3 概要

TLV6703-Q1 高電圧コンパレータは 1.8V ~ 18V の電源電圧範囲で動作します。400mV の基準電圧と定格 18V のオープン・ドレイン出力を内蔵する高精度のコンパレータにより、高精度の電圧検出を実現します。監視対象の電圧は、外付け抵抗を使用して設定することができます。

OUT ピンは、SENSE ピンの電圧が (V_{IT-}) より低くなると LOW に駆動され、対応するスレッシュホールド (V_{IT+}) より高い電圧に戻ると HIGH に復帰します。TLV6703-Q1 のコンパレータは、短時間のグリッチを除去するためヒステリシスが組み込まれているので、誤ったトリガが発生せず、安定した出力動作が保証されます。

TLV6703-Q1 はリードレス WSON-6 パッケージで供給され、-40°C ~ +125°C の接合部温度範囲で動作が規定されています。

製品情報⁽¹⁾

部品番号	パッケージ	本体サイズ (公称)
TLV6703-Q1	WSON (6)	1.50mm × 1.50mm

- (1) 利用可能なすべてのパッケージについては、このデータシートの末尾にあるパッケージ・オプションについての付録を参照してください。

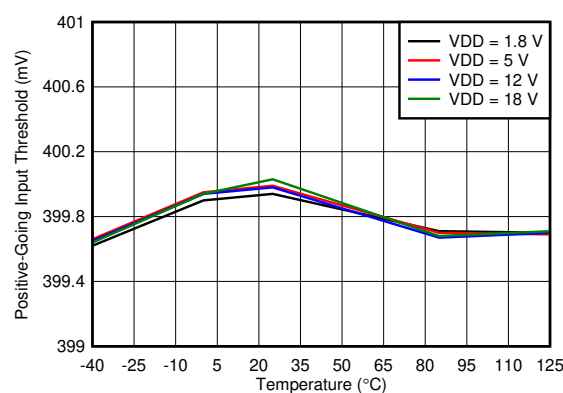

立ち上がり入力スレッシュホールド電圧 (V_{IT+}) と温度との関係



Table of Contents

1 特長	1	8.3 Feature Description.....	11
2 アプリケーション	1	8.4 Device Functional Modes.....	11
3 概要	1	9 Application and Implementation	12
4 Revision History	2	9.1 Application Information.....	12
5 Device Comparison Table	3	9.2 Typical Application.....	14
6 Pin Configuration and Functions	4	9.3 Dos and Don'ts.....	15
7 Specifications	5	10 Power-Supply Recommendations	16
7.1 Absolute Maximum Ratings.....	5	11 Layout	17
7.2 ESD Ratings.....	5	11.1 Layout Guidelines.....	17
7.3 Recommended Operating Conditions.....	5	11.2 Layout Example.....	17
7.4 Thermal Information.....	5	12 Device and Documentation Support	18
7.5 Electrical Characteristics.....	6	12.1 Device Support.....	18
7.6 Timing Requirements.....	7	12.2 Receiving Notification of Documentation Updates..	18
7.7 Switching Characteristics.....	7	12.3 サポート・リソース.....	18
7.8 Timing Diagrams	7	12.4 Trademarks.....	18
7.9 Typical Characteristics.....	8	12.5 静電気放電に関する注意事項.....	18
8 Detailed Description	10	12.6 用語集.....	18
8.1 Overview.....	10	13 Mechanical, Packaging, and Orderable Information	18
8.2 Functional Block Diagram.....	10		

4 Revision History

DATE	REVISION	NOTES
November 2020	*	Initial release.

5 Device Comparison Table

表 5-1. TLV67xx Integrated Comparator Family

PART NUMBER	CONFIGURATION	OPERATING VOLTAGE RANGE	THRESHOLD ACCURACY OVER TEMPERATURE
TLV6700	Window	1.8 V to 18 V	1%
TLV6700-Q1	Window	1.8 V to 18 V	1%
TLV6703	Non-Inverting Single Channel	1.8 V to 18 V	1%
TLV6703-Q1	Non-Inverting Single Channel	1.8 V to 18 V	1%
TLV6710	Window	1.8 V to 36 V	0.75%
TLV6713	Non-Inverting Single Channel	1.8 V to 36 V	0.75%

6 Pin Configuration and Functions



图 6-1. DSE Package, 6-Pin WSON, Top View

表 6-1. Pin Functions

PIN		I/O	DESCRIPTION
NAME	DSE		
GND	1,3,5	—	Connect all three pins to ground.
OUT	6	O	SENSE comparator open-drain output. OUT is driven low when the voltage at this comparator is below (V_{IT-}). The output goes high when the sense voltage returns above the respective threshold (V_{IT+}).
SENSE	4	I	This pin is connected to the voltage to be monitored with the use of an external resistor divider. When the voltage at this pin drops below the threshold voltage (V_{IT-}), OUT is driven low.
VDD	2	I	Supply voltage input. Connect a 1.8-V to 18-V supply to VDD to power the device. Good analog design practice is to place a 0.1- μ F ceramic capacitor close to this pin.

7 Specifications

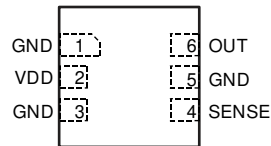
7.1 Absolute Maximum Ratings

over operating temperature range (unless otherwise noted)⁽¹⁾

		MIN	MAX	UNIT
Voltage ⁽²⁾	VDD	-0.3	20	V
	OUT	-0.3	20	
	SENSE	-0.3	7	
Current	OUT (output sink current)		40	mA
Temperature	Operating junction, T _J	-40	125	°C
	Storage, T _{stg}	-65	150	

- (1) Stresses beyond those listed under *Absolute Maximum Ratings* may cause permanent damage to the device. These are stress ratings only, which do not imply functional operation of the device at these or any other conditions beyond those indicated under *Recommended Operating Conditions*. Exposure to absolute-maximum-rated conditions for extended periods may affect device reliability.
- (2) All voltages are with respect to network ground pin.

7.2 ESD Ratings

		VALUE	UNIT
V _(ESD)	Electrostatic discharge	Human body model (HBM), per AEC Q100-002, all pins ⁽¹⁾	±2500
		Charged device model (CDM), per AEC Q100-002, all pins	±1000

- (1) AEC Q100-002 indicates that HBM stressing shall be in accordance with ANSI/ESDA/JEDEC JS-001 specification.

7.3 Recommended Operating Conditions

over operating temperature range (unless otherwise noted)

		MIN	NOM	MAX	UNIT
V _{DD}	Supply voltage	1.8		18	V
V _I	Input voltage	SENSE	0	6.5	V
V _O	Output voltage	OUT	0	18	V

7.4 Thermal Information

THERMAL METRIC ⁽¹⁾		DSE (WSON)	UNIT
		6 PADS	
R _{θJA}	Junction-to-ambient thermal resistance	194.9	°C/W
R _{θJC(top)}	Junction-to-case (top) thermal resistance	128.9	°C/W
R _{θJB}	Junction-to-board thermal resistance	153.8	°C/W
ψ _{JT}	Junction-to-top characterization parameter	11.9	°C/W
ψ _{JB}	Junction-to-board characterization parameter	157.4	°C/W
R _{θJC(bot)}	Junction-to-case (bottom) thermal resistance	N/A	°C/W

- (1) For more information about traditional and new thermal metrics, see the [Semiconductor an IC Package Thermal Metrics](#) application report.

7.5 Electrical Characteristics

Over the operating temperature range of $T_J = -40^{\circ}\text{C}$ to $+125^{\circ}\text{C}$, and $1.8\text{ V} < V_{DD} < 18\text{ V}$ (unless otherwise noted).

Typical values are at $T_J = 25^{\circ}\text{C}$ and $V_{DD} = 5\text{ V}$.

PARAMETER		TEST CONDITIONS	MIN	TYP	MAX	UNIT
$V_{(POR)}$	Power-on reset voltage ⁽¹⁾	$V_{OLmax} = 0.2\text{ V}$, output sink current = $15\ \mu\text{A}$			0.8	V
V_{IT+}	Positive-going input threshold voltage	$V_{DD} = 1.8\text{V}$ and 18 V , $T_J = 25^{\circ}\text{C}$	398	400	402.5	mV
		$V_{DD} = 1.8\text{V}$ and 18 V , $T_J = -40^{\circ}\text{C}$ to 125°C	396		404	
V_{IT-}	Negative-going input threshold voltage	$V_{DD} = 1.8\text{V}$ and 18 V , $T_J = 25^{\circ}\text{C}$	391.6	394.5	397.5	mV
		$V_{DD} = 1.8\text{V}$ and 18 V , $T_J = -40^{\circ}\text{C}$ to 125°C	387		400	
V_{hys}	Hysteresis voltage ($hys = V_{IT+} - V_{IT-}$)			5.5	12	mV
$I_{(SENSE)}$	Input current (at the SENSE pin)	$V_{DD} = 1.8\text{ V}$ and 18 V , $V_I = 6.5\text{ V}$	-25	1	25	nA
V_{OL}	Low-level output voltage	$V_{DD} = 1.8\text{ V}$, output sink current = 3 mA			250	mV
		$V_{DD} = 5\text{ V}$, output sink current = 5 mA			250	
$I_{lk(OD)}$	Open-drain output leakage-current	$V_{DD} = 1.8\text{ V}$ and 18 V , $V_O = V_{DD}$			300	nA
		$V_{DD} = 1.8\text{ V}$, $V_O = 18\text{ V}$			300	
I_{DD}	Supply current	$V_{DD} = 1.8\text{ V}$, no load		5.5	11	μA
		$V_{DD} = 5\text{ V}$		6	13	
		$V_{DD} = 12\text{ V}$		6	13	
		$V_{DD} = 18\text{ V}$		7	13	
UVLO	Undervoltage lockout ⁽²⁾	V_{DD} falling	1.3		1.7	V

(1) The lowest supply voltage (V_{DD}) at which output is active; $t_{r(VDD)} > 15\ \mu\text{s/V}$. Below $V_{(POR)}$, the output cannot be determined.

(2) When V_{DD} falls below UVLO, OUT is driven low. The output cannot be determined below $V_{(POR)}$.

7.6 Timing Requirements

over operating temperature range (unless otherwise noted)

		MIN	NOM	MAX	UNIT
$t_{pd(HL)}$	High-to-low propagation delay ⁽¹⁾	18			μs
$t_{pd(LH)}$	Low-to-high propagation delay ⁽¹⁾	29			μs
$t_{d(start)}$	Start-up delay ⁽²⁾	150			μs

(1) High-to-low and low-to-high refers to the transition at the input pin (SENSE).

(2) During power on, V_{DD} must exceed 1.8 V for at least 150 μs before the output is in a correct state.

7.7 Switching Characteristics

over operating temperature range (unless otherwise noted)

PARAMETER	TEST CONDITIONS	MIN	TYP	MAX	UNIT
t_r	Output rise time $V_{DD} = 5\text{ V}$, 10-mV input overdrive, $R_P = 10\text{ k}\Omega$, $V_O = (0.1\text{ to }0.9) \times V_{DD}$		2.2		μs
t_f	Output fall time $V_{DD} = 5\text{ V}$, 10-mV input overdrive, $R_P = 10\text{ k}\Omega$, $V_O = (0.1\text{ to }0.9) \times V_{DD}$		0.22		μs

7.8 Timing Diagrams

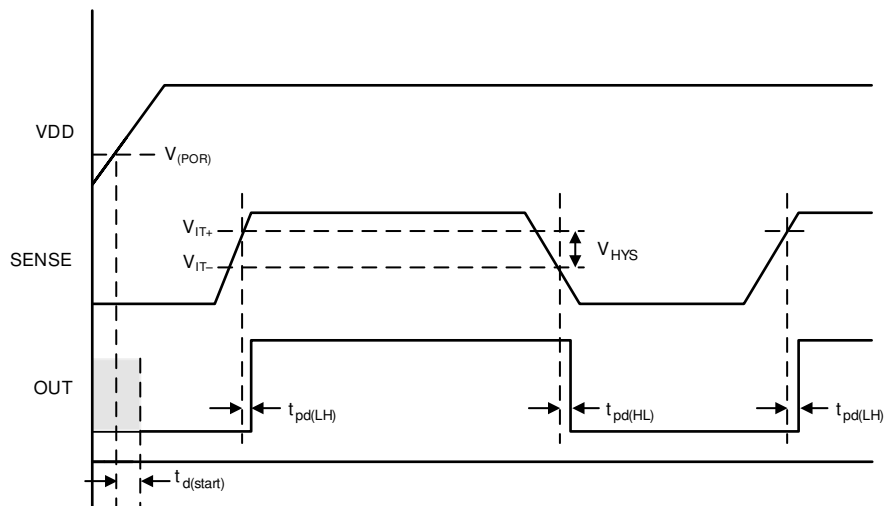
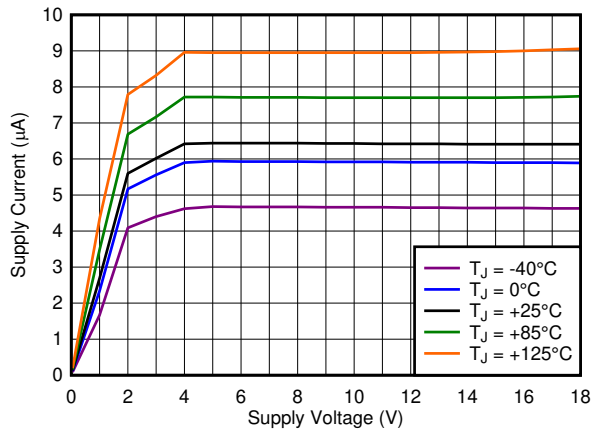

Fig 7-1. Timing Diagram

7.9 Typical Characteristics

at $T_J = 25^\circ\text{C}$ and $V_{DD} = 5\text{ V}$ (unless otherwise noted)



7-2. Supply Current (I_{DD}) vs Supply Voltage (V_{DD})

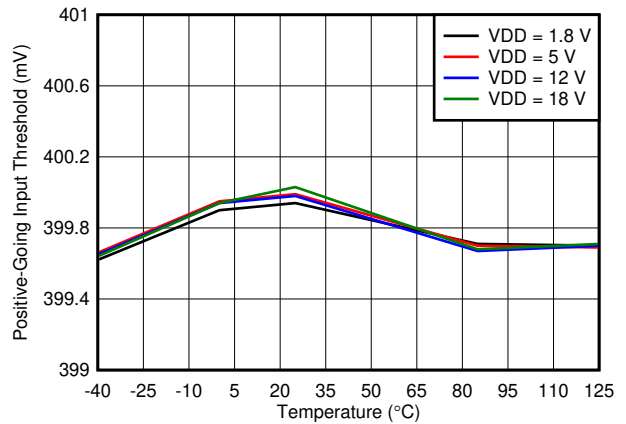

7-3. Rising Input Threshold Voltage (V_{IT+}) vs Temperature

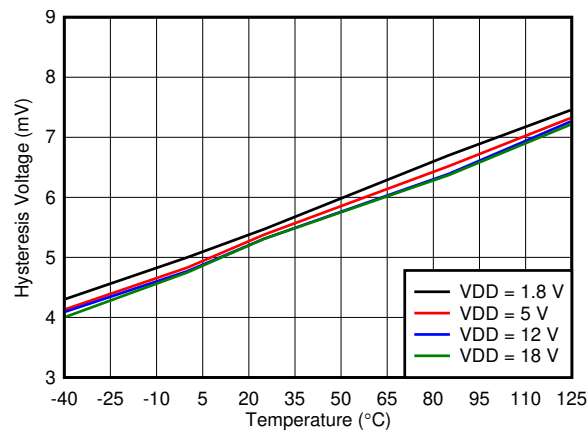

7-4. Hysteresis (V_{hys}) vs Temperature

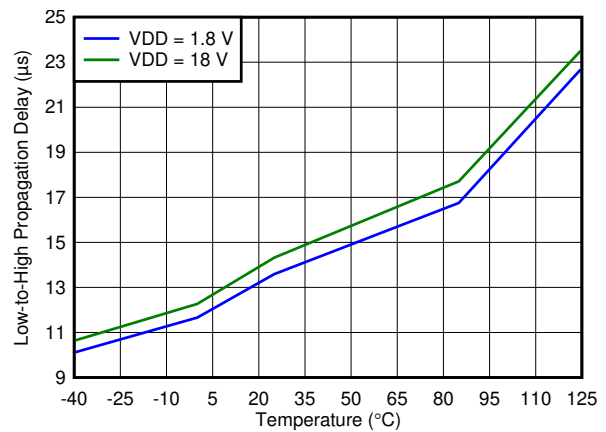

7-5. Propagation Delay vs Temperature (High-to-Low Transition at Sense)

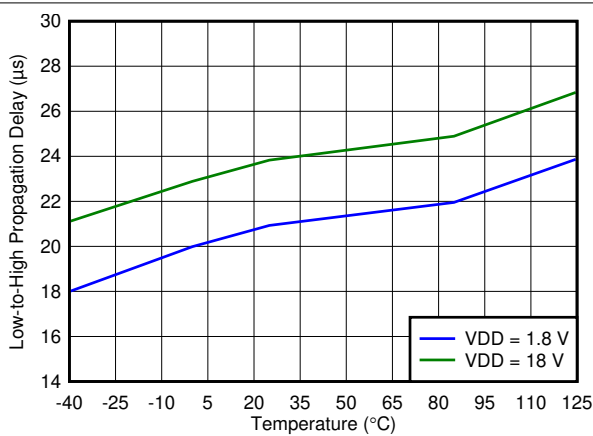

7-6. Propagation Delay vs Temperature (Low-to-High Transition at Sense)

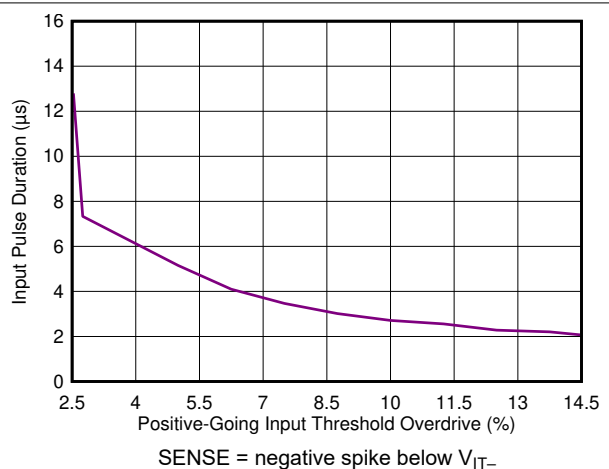

7-7. Minimum Pulse Width vs Threshold Overdrive Voltage

7.9 Typical Characteristics (continued)

at $T_J = 25^\circ\text{C}$ and $V_{DD} = 5\text{ V}$ (unless otherwise noted)

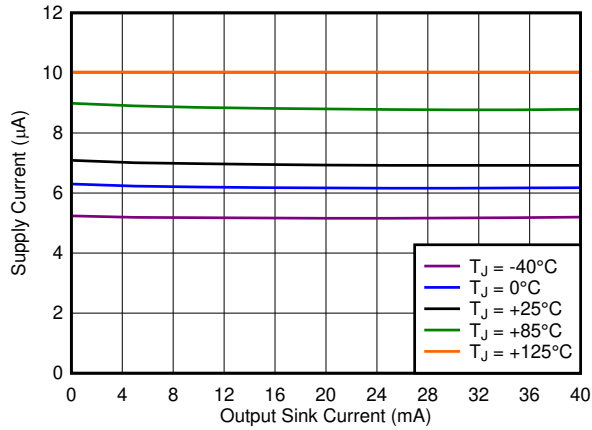

7-8. Supply Current (I_{DD}) vs Output Sink Current

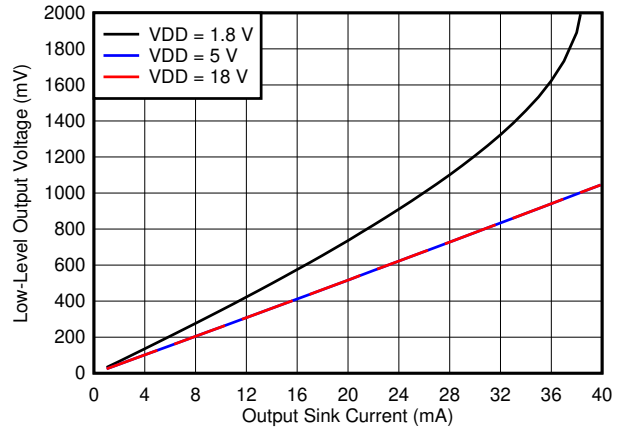

7-9. Output Voltage Low (V_{OL}) vs Output Sink Current (-40°C)

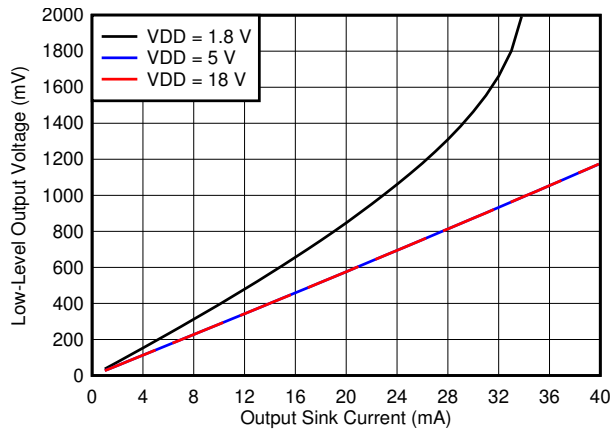

7-10. Output Voltage Low (V_{OL}) vs Output Sink Current (0°C)

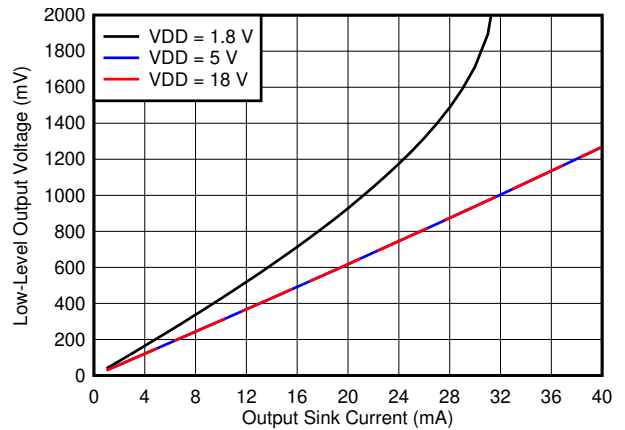

7-11. Output Voltage Low (V_{OL}) vs Output Sink Current (25°C)

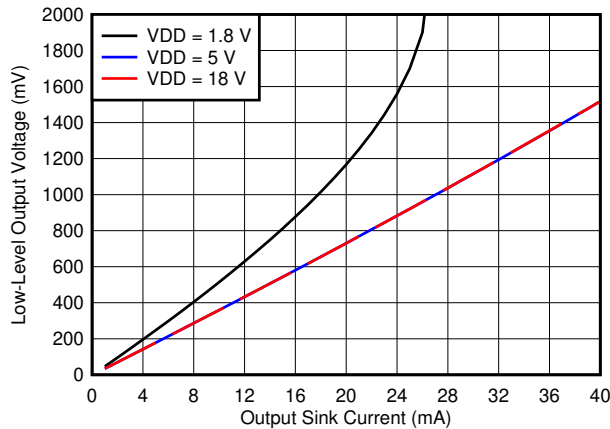

7-12. Output Voltage Low (V_{OL}) vs Output Sink Current (85°C)

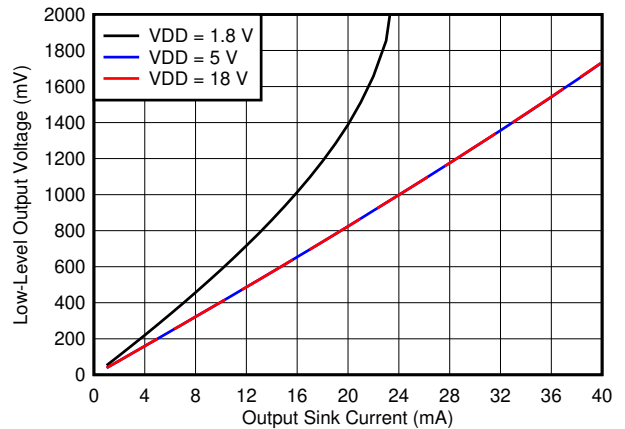

7-13. Output Voltage Low (V_{OL}) vs Output Sink Current (125°C)

8 Detailed Description

8.1 Overview

The TLV6703-Q1 provides precision voltage detection. The TLV6703-Q1 is a wide-supply voltage range (1.8 V to 18 V) comparator with a high-accuracy rising input threshold of 400 mV (1% over temperature) and built-in hysteresis. The output is also rated to 18 V, independent of supply voltage, and can sink up to 40 mA.

The TLV6703-Q1 asserts the output signal, as shown in 表 8-1. To monitor any voltage above 0.4 V, set the input using an external resistor divider network. Each input pin has very low input leakage current, allowing the use of large resistor dividers without sacrificing system accuracy. Broad voltage thresholds are supported that enable the device for use in a wide array of applications.

表 8-1. TLV6703-Q1 Truth Table

CONDITION	OUTPUT	OUTPUT STATE
$SENSE > V_{IT+}$	OUT high	Output high impedance
$SENSE < V_{IT-}$	OUT low	Output sinking

8.2 Functional Block Diagram

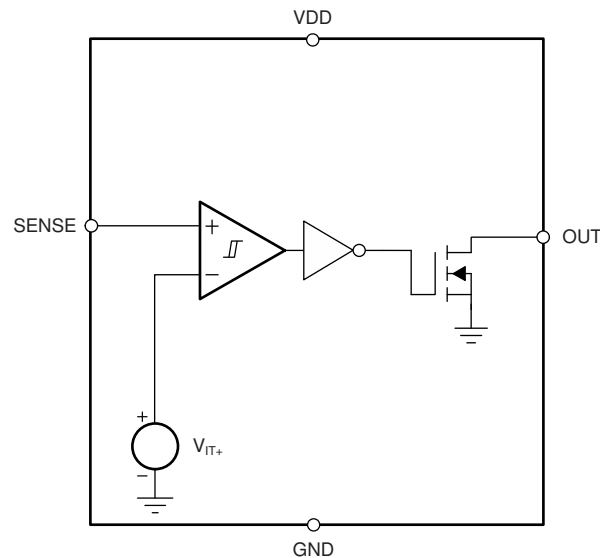

8.3 Feature Description

8.3.1 Input Pin (SENSE)

The TLV6703-Q1 comparator has two inputs: one external input, and one input internally connected to the internal 400mV reference. The comparator rising threshold is trimmed to be equal to the reference voltage (400 mV). The comparator also has a built-in falling hysteresis that makes the device less sensitive to supply-rail noise and provides stable operation.

The comparator input (SENSE) is able to swing from ground to 6.5 V, regardless of the device supply voltage. Although not required in most cases, to reduce sensitivity to transients and layout parasitics for extremely noisy applications, place a 1-nF to 10-nF bypass capacitor at the comparator input.

OUT is driven to logic low when the input SENSE voltage drops below (V_{IT-}). When the voltage exceeds V_{IT+} , the output (OUT) goes to a high-impedance state; see [Figure 7-1](#).

8.3.2 Output Pin (OUT)

In a typical TLV6703-Q1 application, the output is connected to a GPIO input of the processor (such as a digital signal processor [DSP], central processing unit [CPU], field-programmable gate array [FPGA], or application-specific integrated circuit [ASIC]).

The TLV6703-Q1 device provides an open-drain output (OUT). Use a pullup resistor to hold this line high when the output goes to high impedance (not asserted). To connect the output to another device at the correct interface-voltage level, connect a pullup resistor to the proper voltage rail. The TLV6703-Q1 output can be pulled up to 18 V, independent of the device supply voltage.

[Table 8-1](#) and the [Section 8.3.1](#) describe how the output is asserted or deasserted. See for a [Figure 7-1](#) timing diagram that describes the relationship between threshold voltage and the respective output.

8.3.3 Immunity to Input-Pin Voltage Transients

The TLV6703-Q1 is relatively immune to short voltage transient spikes on the sense pin. Sensitivity to transients depends on both transient duration and amplitude; see [Figure 7-7](#), *Minimum Pulse Width vs Threshold Overdrive Voltage*.

8.4 Device Functional Modes

8.4.1 Normal Operation ($V_{DD} > UVLO$)

When the voltage on V_{DD} is greater than 1.8 V for at least 150 μ s, the OUT signal correspond to the voltage on SENSE as listed in [Table 8-1](#).

8.4.2 Undervoltage Lockout ($V_{(POR)} < V_{DD} < UVLO$)

When the voltage on V_{DD} is less than the device UVLO voltage, and greater than the power-on reset voltage, $V_{(POR)}$, the OUT signal is asserted regardless of the voltage on SENSE.

8.4.3 Power-On Reset ($V_{DD} < V_{(POR)}$)

When the voltage on V_{DD} is lower than the required voltage to internally pull the asserted output to GND ($V_{(POR)}$), SENSE is in a high-impedance state.

9 Application and Implementation

Note

以下のアプリケーション情報は、TI の製品仕様に含まれるものではなく、TI ではその正確性または完全性を保証いたしません。個々の目的に対する製品の適合性については、お客様の責任で判断していただくこととなります。お客様は自身の設計実装を検証しテストすることで、システムの機能を確認する必要があります。

9.1 Application Information

The TLV6703-Q1 device is a wide-supply voltage comparator that operates over a V_{DD} range of 1.8 V to 18 V. The device has a high-accuracy comparator with an internal 400-mV reference and an open-drain output rated to 18 V for precision voltage detection. The device can be used as a voltage monitor. The monitored voltage are set with the use of external resistors.

9.1.1 V_{PULLUP} to a Voltage Other Than V_{DD}

The output is often tied to V_{DD} through a resistor. However, some applications may require the output to be pulled up to a higher or lower voltage than V_{DD} to correctly interface with the reset and enable pins of other devices.



図 9-1. Interfacing to a Voltage Other Than V_{DD}

9.1.2 Monitoring V_{DD}

Many applications monitor the same rail that is powering V_{DD} . In these applications the resistor divider is simply connected to the V_{DD} rail.

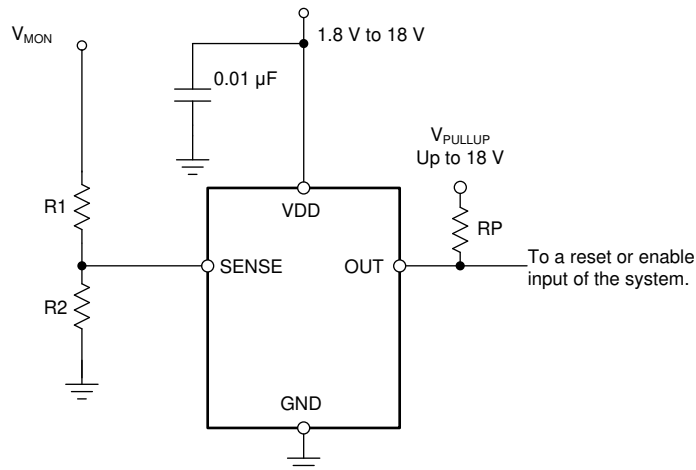
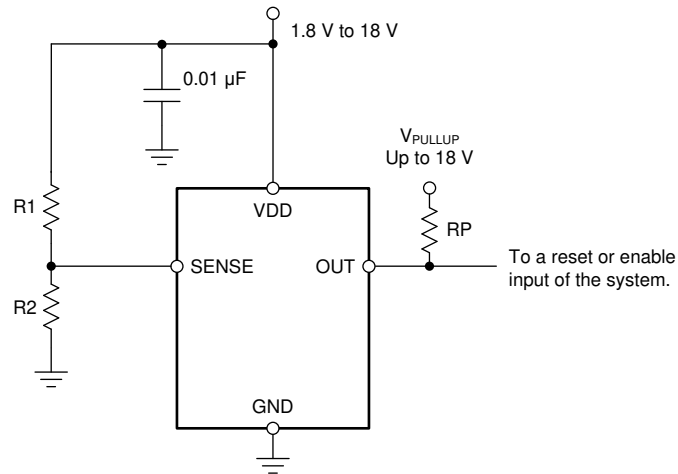

9-2. Monitoring the Same Voltage as V_{DD}

9.1.3 Monitoring a Voltage Other Than V_{DD}

Some applications monitor rails other than the one that is powering V_{DD} . In these types of applications the resistor divider used to set the desired threshold is connected to the rail that is being monitored.

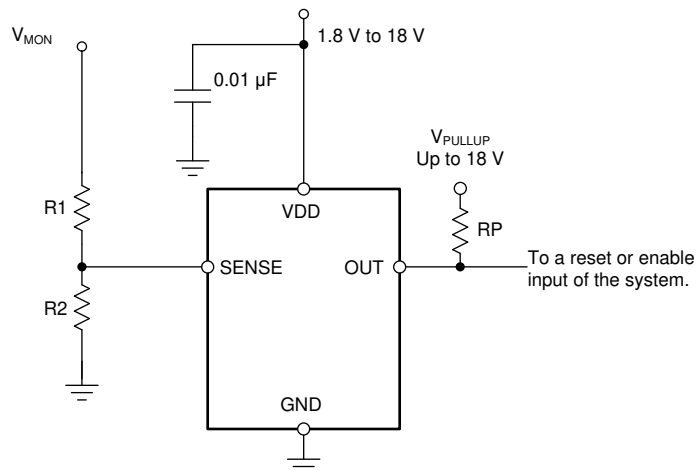

NOTE: The input can monitor a voltage greater than maximum V_{DD} with the use of an external resistor divider network.

9-3. Monitoring a Voltage Other Than V_{DD}

9.2 Typical Application

The TLV6703-Q1 device is a wide-supply voltage comparator that operates over a V_{DD} range of 1.8 to 18 V. The monitored voltage is set with the use of external resistors, so the device can be used either as a precision voltage monitor.



图 9-4. Wide VIN Voltage Monitor

9.2.1 Design Requirements

For this design example, use the values summarized in 表 9-1 as the input parameters.

表 9-1. Design Parameters

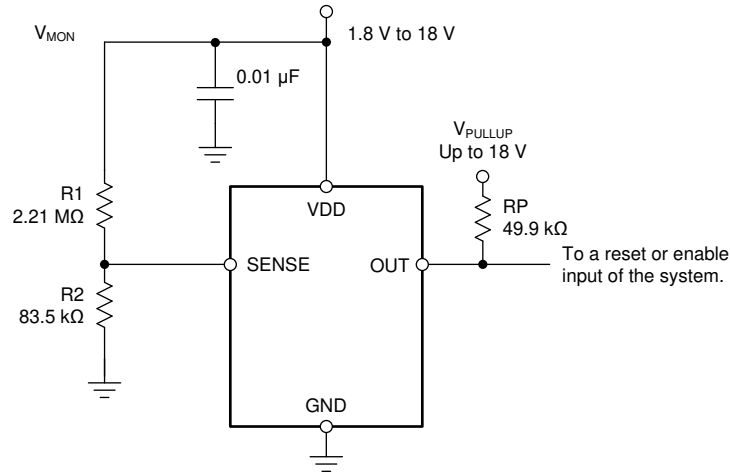
PARAMETER	DESIGN REQUIREMENT	DESIGN RESULT
Monitored voltage	12-V nominal rail with maximum falling threshold of 10%	$V_{MON(UV)} = 10.99 \text{ V (8.33\%)}$

9.2.2 Detailed Design Procedure

9.2.2.1 Resistor Divider Selection

The resistor divider values and target threshold voltage can be calculated by using 式 1 to determine $V_{MON(UV)}$.

$$V_{MON(UV)} = \left(1 + \frac{R1}{R2} \right) \times V_{IT-} \quad (1)$$

where

- R1 and R2 are the resistor values for the resistor divider on the SENSEx pins
- $V_{MON(UV)}$ is the target voltage at which an undervoltage condition is detected

Choose R_{TOTAL} ($= R1 + R2$) so that the current through the divider is approximately 100 times higher than the input current at the SENSE pin. The resistors can have high values to minimize current consumption as a result of low input bias current without adding significant error to the resistive divider. For details on sizing input resistors, refer to application report [SLVA450, Optimizing Resistor Dividers at a Comparator Input](#), available for download from www.ti.com.

9.2.2.2 Pullup Resistor Selection

To ensure the proper voltage level, the pullup resistor value is selected by ensuring that the pullup voltage divided by the resistor does not exceed the sink-current capability of the device. This confirmation is calculated by verifying that the pullup voltage minus the output-leakage current ($I_{\text{kg(OD)}}$) multiplied by the resistor is greater than the desired logic-high voltage. These values are specified in the [セクション 7.5](#).

Use [式 2](#) to calculate the value of the pullup resistor.

$$\frac{(V_{\text{HI}} - V_{\text{PU}})}{I_{\text{kg(OD)}}} \geq R_{\text{PU}} \geq \frac{V_{\text{PU}}}{I_{\text{O}}} \quad (2)$$

9.2.2.3 Input Supply Capacitor

Although an input capacitor is not required for stability, for good analog design practice, connect a 0.1- μF low equivalent series resistance (ESR) capacitor across the VDD and GND pins. A higher-value capacitor may be necessary if large, fast rise-time load transients are anticipated, or if the device is not located close to the power source.

9.2.2.4 Sense Capacitor

Although not required in most cases, for extremely noisy applications, place a 1-nF to 10-nF bypass capacitor from the comparator input (SENSE) to the GND pin for good analog design practice. This capacitor placement reduces device sensitivity to transients.

9.2.3 Application Curves



图 9-5. Rising Input Threshold Voltage ($V_{\text{IT+}}$) vs Temperature

9.3 Dos and Don'ts

Do connect a 0.1- μF decoupling capacitor from V_{DD} to GND for best system performance.

If the monitored rail is noisy, do connect a decoupling capacitor from the comparator input (sense) to GND.

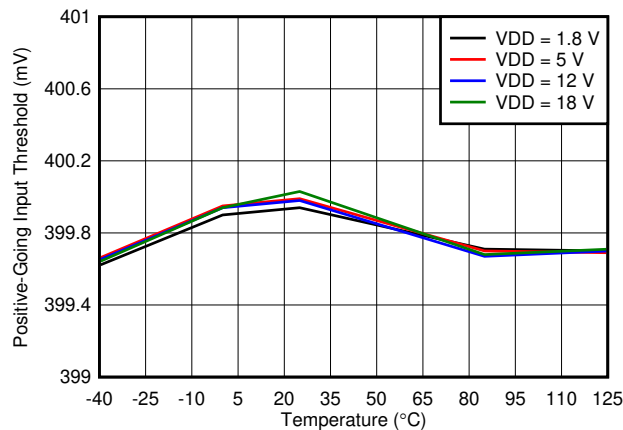
Don't use resistors for the voltage divider that cause the current through them to be less than 100 times the input current of the comparator without also accounting for the effect to the accuracy.

Don't use a pullup resistor that is too small, because the larger current sunk by the output then exceeds the desired low-level output voltage (V_{OL}).

10 Power-Supply Recommendations

These devices operate from an input voltage supply range between 1.8 V and 18 V.

11 Layout

11.1 Layout Guidelines

Placing a 0.1- μF capacitor close to the VDD pin to reduce the input impedance to the device is good analog design practice.

11.2 Layout Example

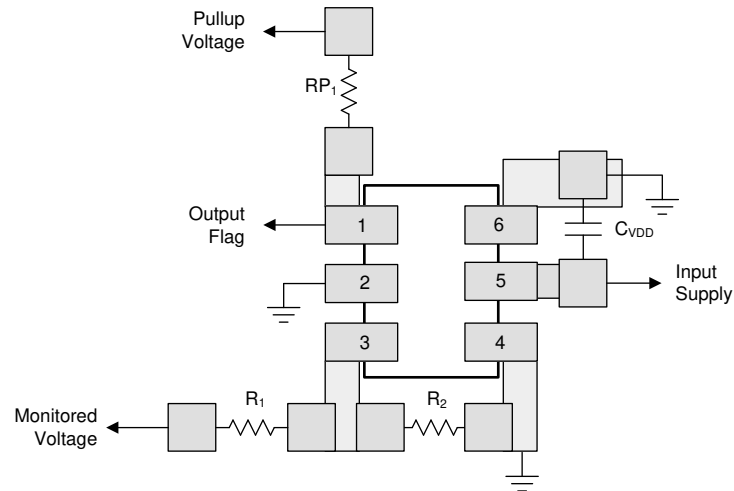

 11-1. Layout Example

12 Device and Documentation Support

12.1 Device Support

12.1.1 Development Support

The [DIP Adapter Evaluation Module](#) allows conversion of the SOT-23-6 package to a standard DIP-6 pinout for ease of prototyping and bench evaluation.

12.2 Receiving Notification of Documentation Updates

To receive notification of documentation updates, navigate to the device product folder on ti.com. In the upper right corner, click on *Alert me* to register and receive a weekly digest of any product information that has changed. For change details, review the revision history included in any revised document.

12.3 サポート・リソース

TI E2E™ サポート・フォーラムは、エンジニアが検証済みの回答と設計に関するヒントをエキスパートから迅速かつ直接得ることができる場所です。既存の回答を検索したり、独自の質問をしたりすることで、設計に必要な支援を迅速に得ることができます。

リンクされているコンテンツは、該当する貢献者により、現状のまま提供されるものです。これらは TI の仕様を構成するものではなく、必ずしも TI の見解を反映したものではありません。TI の [使用条件](#) を参照してください。

12.4 Trademarks

TI E2E™ is a trademark of Texas Instruments.

すべての商標は、それぞれの所有者に帰属します。

12.5 静電気放電に関する注意事項



この IC は、ESD によって破損する可能性があります。テキサス・インスツルメンツは、IC を取り扱う際には常に適切な注意を払うことを推奨します。正しい ESD 対策をとらないと、デバイスを破損するおそれがあります。

ESD による破損は、わずかな性能低下からデバイスの完全な故障まで多岐にわたります。精密な IC の場合、パラメータがわずかに変化するだけで公表されている仕様から外れる可能性があるため、破損が発生しやすくなっています。

12.6 用語集

TI 用語集 この用語集には、用語や略語の一覧および定義が記載されています。

13 Mechanical, Packaging, and Orderable Information

The following pages include mechanical, packaging, and orderable information. This information is the most current data available for the designated devices. This data is subject to change without notice and revision of this document. For browser-based versions of this data sheet, refer to the left-hand navigation.

PACKAGING INFORMATION

Orderable Device	Status (1)	Package Type	Package Drawing	Pins	Package Qty	Eco Plan (2)	Lead finish/ Ball material (6)	MSL Peak Temp (3)	Op Temp (°C)	Device Marking (4/5)	Samples
TLV6703QDSERQ1	ACTIVE	WSO8	DSE	6	3000	RoHS & Green	NIPDAUAG	Level-2-260C-1 YEAR	-40 to 125	K7	Samples

(1) The marketing status values are defined as follows:

ACTIVE: Product device recommended for new designs.

LIFEBUY: TI has announced that the device will be discontinued, and a lifetime-buy period is in effect.

NRND: Not recommended for new designs. Device is in production to support existing customers, but TI does not recommend using this part in a new design.

PREVIEW: Device has been announced but is not in production. Samples may or may not be available.

OBSELETE: TI has discontinued the production of the device.

(2) **RoHS:** TI defines "RoHS" to mean semiconductor products that are compliant with the current EU RoHS requirements for all 10 RoHS substances, including the requirement that RoHS substance do not exceed 0.1% by weight in homogeneous materials. Where designed to be soldered at high temperatures, "RoHS" products are suitable for use in specified lead-free processes. TI may reference these types of products as "Pb-Free".

RoHS Exempt: TI defines "RoHS Exempt" to mean products that contain lead but are compliant with EU RoHS pursuant to a specific EU RoHS exemption.

Green: TI defines "Green" to mean the content of Chlorine (Cl) and Bromine (Br) based flame retardants meet JS709B low halogen requirements of <=1000ppm threshold. Antimony trioxide based flame retardants must also meet the <=1000ppm threshold requirement.

(3) MSL, Peak Temp. - The Moisture Sensitivity Level rating according to the JEDEC industry standard classifications, and peak solder temperature.

(4) There may be additional marking, which relates to the logo, the lot trace code information, or the environmental category on the device.

(5) Multiple Device Markings will be inside parentheses. Only one Device Marking contained in parentheses and separated by a "-" will appear on a device. If a line is indented then it is a continuation of the previous line and the two combined represent the entire Device Marking for that device.

(6) Lead finish/Ball material - Orderable Devices may have multiple material finish options. Finish options are separated by a vertical ruled line. Lead finish/Ball material values may wrap to two lines if the finish value exceeds the maximum column width.

Important Information and Disclaimer:The information provided on this page represents TI's knowledge and belief as of the date that it is provided. TI bases its knowledge and belief on information provided by third parties, and makes no representation or warranty as to the accuracy of such information. Efforts are underway to better integrate information from third parties. TI has taken and continues to take reasonable steps to provide representative and accurate information but may not have conducted destructive testing or chemical analysis on incoming materials and chemicals. TI and TI suppliers consider certain information to be proprietary, and thus CAS numbers and other limited information may not be available for release.

In no event shall TI's liability arising out of such information exceed the total purchase price of the TI part(s) at issue in this document sold by TI to Customer on an annual basis.

TAPE AND REEL INFORMATION



QUADRANT ASSIGNMENTS FOR PIN 1 ORIENTATION IN TAPE



*All dimensions are nominal

Device	Package Type	Package Drawing	Pins	SPQ	Reel Diameter (mm)	Reel Width W1 (mm)	A0 (mm)	B0 (mm)	K0 (mm)	P1 (mm)	W (mm)	Pin1 Quadrant
TLV6703QDSERQ1	WSON	DSE	6	3000	180.0	8.4	1.8	1.8	1.0	4.0	8.0	Q2

TAPE AND REEL BOX DIMENSIONS



*All dimensions are nominal

Device	Package Type	Package Drawing	Pins	SPQ	Length (mm)	Width (mm)	Height (mm)
TLV6703QDSERQ1	WSON	DSE	6	3000	213.0	191.0	35.0

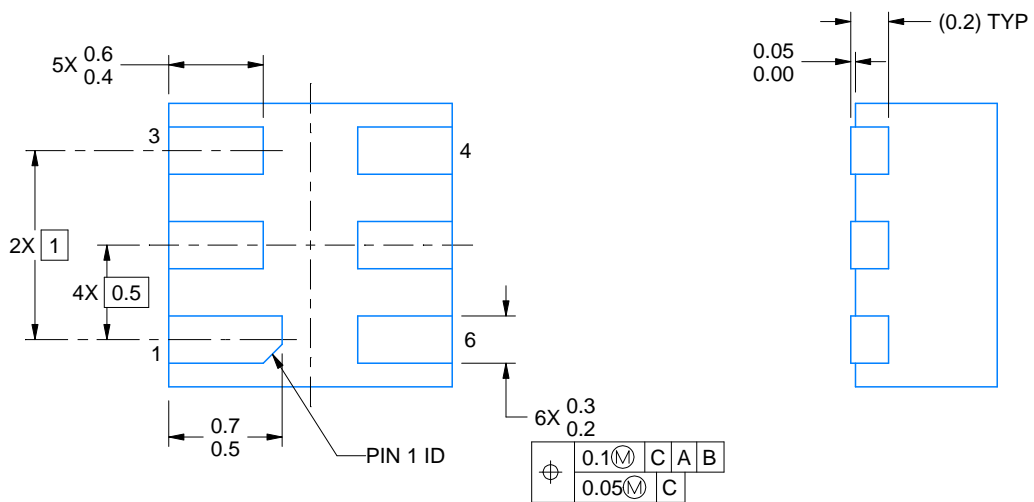
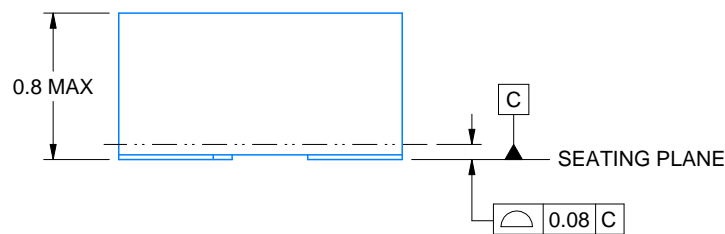
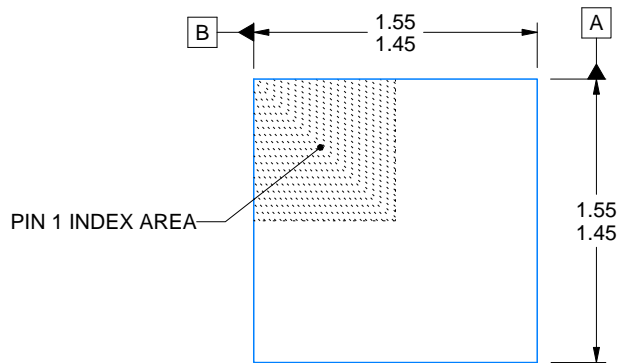

4220552/B 01/2024

NOTES:

1. All linear dimensions are in millimeters. Any dimensions in parenthesis are for reference only. Dimensioning and tolerancing per ASME Y14.5M.
2. This drawing is subject to change without notice.

EXAMPLE BOARD LAYOUT

DSE0006A

WSON - 0.8 mm max height

PLASTIC SMALL OUTLINE - NO LEAD

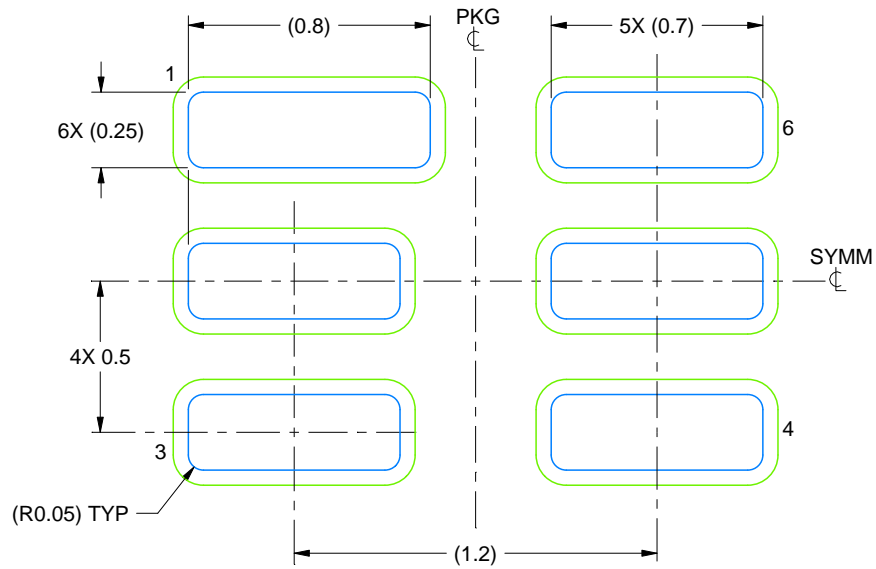

LAND PATTERN EXAMPLE
SCALE:40X

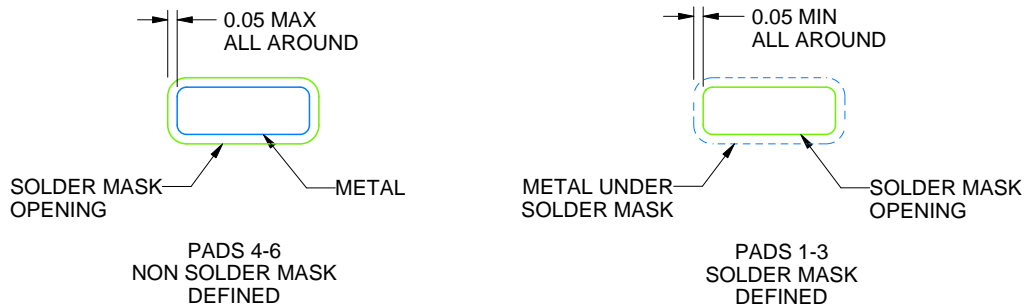

SOLDER MASK DETAILS

4220552/B 01/2024

NOTES: (continued)

3. For more information, see Texas Instruments literature number SLUA271 (www.ti.com/lit/slua271).

EXAMPLE STENCIL DESIGN

DSE0006A

WSON - 0.8 mm max height

PLASTIC SMALL OUTLINE - NO LEAD

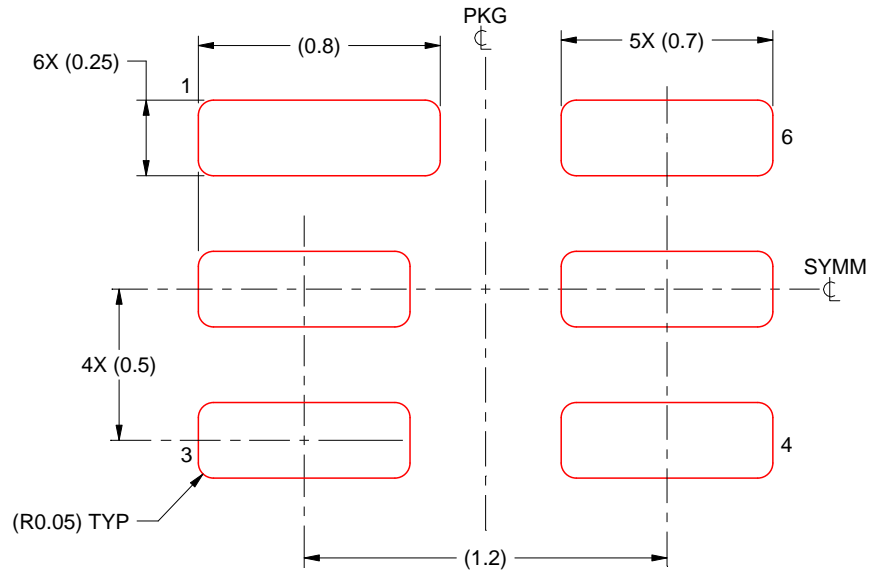

SOLDER PASTE EXAMPLE
BASED ON 0.125 mm THICK STENCIL
SCALE:40X

NOTES: (continued)

4. Laser cutting apertures with trapezoidal walls and rounded corners may offer better paste release. IPC-7525 may have alternate design recommendations.

重要なお知らせと免責事項

TI は、技術データと信頼性データ(データシートを含みます)、設計リソース(リファレンス・デザインを含みます)、アプリケーションや設計に関する各種アドバイス、Web ツール、安全性情報、その他のリソースを、欠陥が存在する可能性のある「現状のまま」提供しており、商品性および特定目的に対する適合性の黙示保証、第三者の知的財産権の非侵害保証を含むいかなる保証も、明示的または黙示的にかかわらず拒否します。

これらのリソースは、TI 製品を使用する設計の経験を積んだ開発者への提供を意図したものです。(1) お客様のアプリケーションに適した TI 製品の選定、(2) お客様のアプリケーションの設計、検証、試験、(3) お客様のアプリケーションに該当する各種規格や、その他のあらゆる安全性、セキュリティ、規制、または他の要件への確実な適合に関する責任を、お客様のみが単独で負うものとします。

上記の各種リソースは、予告なく変更される可能性があります。これらのリソースは、リソースで説明されている TI 製品を使用するアプリケーションの開発の目的でのみ、TI はその使用をお客様に許諾します。これらのリソースに関して、他の目的で複製することや掲載することは禁止されています。TI や第三者の知的財産権のライセンスが付与されている訳ではありません。お客様は、これらのリソースを自身で使用した結果発生するあらゆる申し立て、損害、費用、損失、責任について、TI およびその代理人を完全に補償するものとし、TI は一切の責任を拒否します。

TI の製品は、[TI の販売条件](#)、または [ti.com](#) やかかる TI 製品の関連資料などのいずれかを通じて提供する適用可能な条項の下で提供されています。TI がこれらのリソースを提供することは、適用される TI の保証または他の保証の放棄の拡大や変更を意味するものではありません。

お客様がいかなる追加条項または代替条項を提案した場合でも、TI はそれらに異議を唱え、拒否します。

郵送先住所 : Texas Instruments, Post Office Box 655303, Dallas, Texas 75265
Copyright © 2024, Texas Instruments Incorporated