

TLVM13640 高密度、3V~36V 入力、1V~6V 出力、4A 同期整流式降圧 DC/DC パワー・モジュール、Enhanced HotRod™ QFN パッケージ

1 特長

- 用途の広い同期整流式降圧 DC/DC パワー・モジュール
 - MOSFET、インダクタ、コントローラを内蔵
 - 広い入力電圧範囲：3V~36V
 - 出力電圧を調整可能 1V~6V、温度範囲全体にわたってセットポイント精度 1%
 - 5.0mm × 5.5mm × 4mm のオーバーモールド・パッケージ
 - 40°C ~ 125°C の接合部温度範囲
 - 200kHz ~ 2.2MHz の範囲で周波数を調整可能
 - 負電圧出力に対応可能
- 全負荷範囲にわたって極めて高い効率を実現
 - 95% 以上のピーク効率
 - 外部バイアス・オプションによる効率向上
 - シャットダウン時静止電流：0.6μA (標準値)
 - 4A 負荷でのドロップアウト電圧：0.5V (標準値)
- 非常に小さい伝導および放射 EMI シグネチャ
 - デュアル入力パスと内蔵コンデンサを備えた低ノイズ・パッケージにより、スイッチのリングングが減少
 - 抵抗により調整可能なスイッチ・ノードのスルーレート
 - 固定周波数 FPWM 動作モード
 - CISPR 11 および 32 Class B の放射規格に準拠
- スケーラブルな電源に好適
 - TLVM13660 (36V、6A) とピン互換
- 堅牢な設計のための本質的な保護機能
 - 高精度のイネーブル入力とオープン・ドレインの PGOOD インジケータによるシーケンシング、制御、 V_{IN} UVLO
 - 過電流およびサーマル・シャットダウン保護機能
- WEBENCH® Power Designer により、TLVM13640 を使用するカスタム設計を作成

2 アプリケーション

- 試験および測定、航空宇宙および防衛
- ファクトリ・オートメーション / 制御
- 降圧および反転型の昇降圧電源

3 概要

同期整流式降圧モジュール・ファミリから派生した TLVM13640 は、パワー MOSFET、シールド付きインダクタ、受動部品を Enhanced HotRod™ QFN パッケージに実装した高集積 36V、4A DC/DC ソリューションです。このモジュールは、VIN および VOUT ピンをパッケージの角に配置し、入力および出力コンデンサの配置を最適化しています。モジュールの下面には大きな 4 つのサーマル・パッドがあるため、単純なレイアウトが可能で、製造時の扱いも容易です。

出力電圧範囲が 1V~6V であるため、TLVM13640 は小さな PCB フットプリントで低 EMI の設計を迅速かつ容易に実装できるよう設計されています。このトータル・ソリューションを使用すると、外付け部品はわずか 4 個で済み、設計プロセスで磁気および補償のための部品選択も不要です。

TLVM13640 モジュールは、スペースが制約される用途での小型化と簡素化をめざして設計されているだけでなく、堅牢性の高い性能を実現するためのさまざまな機能を備えています。その例としては、可変入力電圧 UVLO 用のヒステリシス付き高精度イネーブル、抵抗を使ってプログラム可能なスイッチ・ノードのスルーレートによる EMI 改善、内蔵 VCC、ブートストラップおよび入力コンデンサによる信頼性向上と高密度化、全負荷電流範囲にわたって一定のスイッチング周波数、負電圧出力能力、シーケンシング、障害保護、出力電圧監視用の PGOOD インジケータがあります。

製品情報

部品番号	パッケージ ⁽¹⁾	本体サイズ (公称)
TLVM13640	B3QFN (20)	5.0mm × 5.5mm

- (1) 利用可能なパッケージについては、このデータシートの末尾にある注文情報を参照してください。



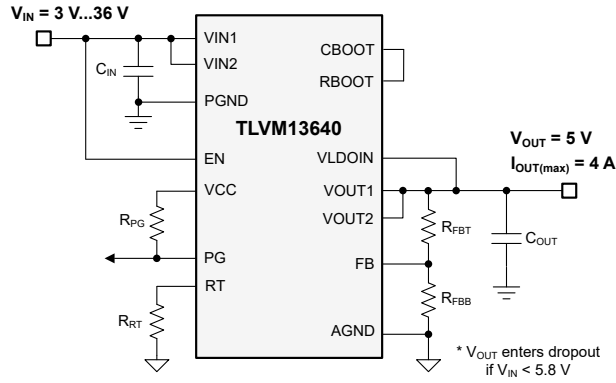

代表的な回路図

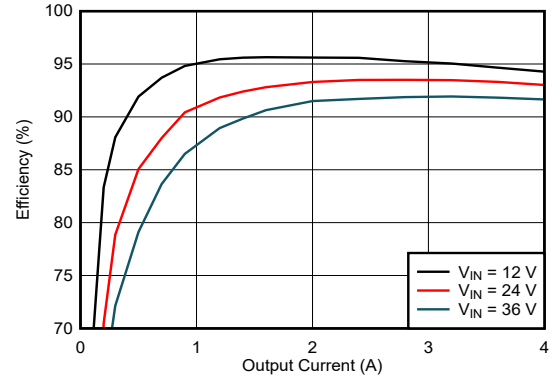

代表的な効率 ($V_{OUT} = 5V$ 、 $f_{sw} = 1MHz$)

Table of Contents

1 特長	1	8.3 Feature Description.....	15
2 アプリケーション	1	8.4 Device Functional Modes.....	20
3 概要	1	9 Applications and Implementation	21
4 Revision History	3	9.1 Application Information.....	21
5 Device Comparison Table	4	9.2 Typical Applications.....	21
6 Pin Configuration and Functions	4	10 Power Supply Recommendations	29
7 Specifications	6	11 Layout	30
7.1 Absolute Maximum Ratings.....	6	11.1 Layout Guidelines.....	30
7.2 ESD Ratings.....	6	11.2 Layout Example.....	31
7.3 Recommended Operating Conditions.....	7	12 Device and Documentation Support	33
7.4 Thermal Information.....	7	12.1 Device Support.....	33
7.5 Electrical Characteristics.....	8	12.2 Documentation Support.....	34
7.6 System Characteristics.....	9	12.3 Receiving Notification of Documentation Updates.....	34
7.7 Typical Characteristics.....	10	12.4 サポート・リソース.....	34
7.8 Typical Characteristics ($V_{IN} = 12\text{ V}$).....	12	12.5 Trademarks.....	34
7.9 Typical Characteristics ($V_{IN} = 24\text{ V}$).....	13	12.6 Electrostatic Discharge Caution.....	34
8 Detailed Description	14	12.7 Glossary.....	34
8.1 Overview.....	14	13 Mechanical, Packaging, and Orderable Information	35
8.2 Functional Block Diagram.....	14		

4 Revision History

DATE	REVISION	NOTES
April 2022	*	Initial release

5 Device Comparison Table

Device	Orderable Part Number	Rated Output Current	Junction Temperature Range	External Sync ⁽¹⁾
TLVM13620	TLVM13620RDHR	2 A	–40°C to 125°C	No
TLVM13630	TLVM13630RDHR	3 A	–40°C to 125°C	No
TLVM13640	TLVM13640RDLR	4 A	–40°C to 125°C	No
TLVM13660	TLVM13660RDLR	6 A	–40°C to 125°C	No

(1) See the [TPSM63602](#), [TPSM63603](#), [TPSM63604](#), and [TPSM63606](#) for applications that require clock synchronization, an output voltage above 6 V, spread-spectrum modulation for EMI mitigation or both.

6 Pin Configuration and Functions



图 6-1. 20-Pin QFN RDL Package (Top View)

表 6-1. Pin Functions

Pin		Type ⁽¹⁾	Description
Name	NO.		
VIN1, VIN2	1, 16	P	Input supply voltage. Connect the input supply to these pins. Connect input capacitors between these pins and PGND in close proximity to the device.
SW	2	O	Switch node. Do not place any external component on this pin or connect to any signal. The amount of copper placed on this pin must be kept to a minimum to prevent issues with noise and EMI.
CBOOT	3	I/O	Bootstrap pin for the internal high-side gate driver. A 100-nF bootstrap capacitor is internally connected from this pin to SW within the module to provide the bootstrap voltage. CBOOT is brought out to use in conjunction with RBOOT to effectively lower the value of the internal series bootstrap resistance to adjust the switch-node slew rate, if necessary.
RBOOT	4	I/O	External bootstrap resistor connection. Internal to the device, a 100-Ω bootstrap resistor is connected between RBOOT and CBOOT. RBOOT is brought out to use in conjunction with CBOOT to effectively lower the value of the internal series bootstrap resistance to adjust the switch-node slew rate, if necessary.
VLDOIN	5	P	Input bias voltage. Input to the internal LDO that supplies the internal control circuits. Connect to an output voltage point to improve efficiency. Connect an optional high-quality 0.1-μF to 1-μF capacitor from this pin to ground for improved noise immunity. If the output voltage is above 12 V, connect this pin to ground.

表 6-1. Pin Functions (continued)

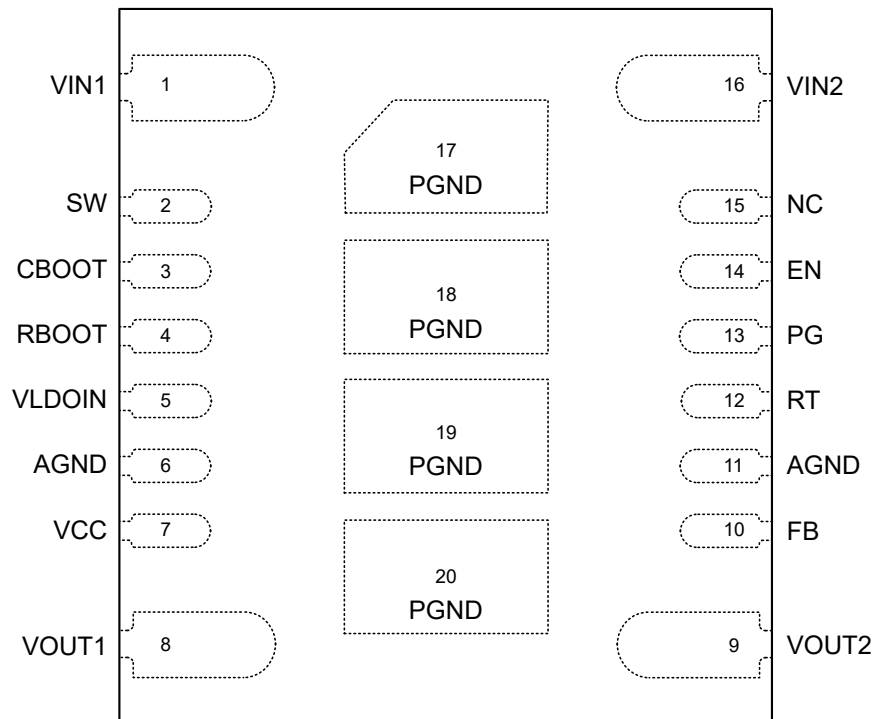
Pin		Type ⁽¹⁾	Description
Name	NO.		
AGND	6, 11	G	Analog ground. Zero-voltage reference for internal references and logic. All electrical parameters are measured with respect to this pin. <i>These pins must be connected to PGND.</i> See セクション 11.2 for a recommended layout.
VCC	7	O	Internal LDO output. Used as a supply to the internal control circuits. Do not connect to any external loads. A 1- μ F capacitor internally connects from VCC to AGND.
VOUT1, VOUT2	8, 9	P	Output voltage. These pins are connected to the internal buck inductor. Connect these pins to the output load and connect external output capacitors between these pins and PGND.
FB	10	I	Feedback input. Connect the midpoint of the feedback resistor divider to this pin. Connect the upper resistor (R_{FBT}) of the feedback divider to V_{OUT} at the desired point of regulation. Connect the lower resistor (R_{FBB}) of the feedback divider to AGND. Do not leave open or connect to ground.
RT	12	I	Frequency setting pin used to set the switching frequency between 200 kHz and 2.2 MHz by placing an external resistor from RT to AGND. Do not leave open or connect to ground.
PG	13	O	Open-drain power-good monitor output that asserts low if the FB voltage is not within the specified window thresholds. A 10-k Ω to 100-k Ω pullup resistor to a suitable voltage is required. If not used, PG can be left open or connected to GND.
EN	14	I	Precision enable input pin. High = on, Low = off. Can be connected to VIN. Precision enable allows the pin to be used as an adjustable input voltage UVLO. The module can be turned off by using an open-drain/collector device to connect this pin to AGND. Connect an external resistor divider between this pin, VIN and AGND to create an external UVLO.
NC	15	—	No connection. Tie to GND or leave open.
PGND	17, 18, 19, 20	G	Power ground. This is the return current path for the power stage of the device. Connect these pads to the input supply return, the load return, and the capacitors associated with the VIN and VOUT pins. See セクション 11.2 for a recommended layout.

(1) P = Power, G = Ground, I = Input, O = Output

7 Specifications

7.1 Absolute Maximum Ratings

Limits apply over $T_J = -40^{\circ}\text{C}$ to 150°C (unless otherwise noted). ⁽¹⁾

		MIN	MAX	UNIT
Input voltage	VIN1, VIN2 to AGND, PGND	-0.3	42	V
	RBOOT to SW	-0.3	5.5	V
	CBOOT to SW	-0.3	5.5	V
	VLDOIN to AGND, PGND	-0.3	min ($V_{VIN} + 0.3, 16$)	V
	EN to AGND, PGND	-0.3	42	V
	RT to AGND, PGND	-0.3	5.5	V
	FB to AGND, PGND	-0.3	16	V
	PG to AGND, PGND	0	20	V
	PGND to AGND	-1	2	V
Output voltage	VCC to AGND, PGND	-0.3	5.5	V
	SW to AGND, PGND ⁽²⁾	-0.3	42	V
	VOUT1, VOUT2 to AGND, PGND	-0.3	6	V
Input current	PG		10	mA
T_J	Junction temperature	-40	150	$^{\circ}\text{C}$
T_A	Ambient temperature	-40	125	$^{\circ}\text{C}$
T_{stg}	Storage temperature	-55	150	$^{\circ}\text{C}$
Peak reflow case temperature			250	$^{\circ}\text{C}$
Maximum number of reflows allowed			3	
Mechanical vibration	MIL-STD-883D, Method 2007.2, 20 Hz to 2 kHz		20	G
Mechanical shock	MIL-STD-883D, Method 2002.3, 1 ms, 1/2 sine, mounted		500	G

- (1) Operation outside the *Absolute Maximum Ratings* may cause permanent device damage. *Absolute Maximum Ratings* do not imply functional operation of the device at these or any other conditions beyond those listed under *Recommended Operating Conditions*. If used outside the *Recommended Operating Conditions* but within the *Absolute Maximum Ratings*, the device may not be fully functional, and this may affect device reliability, functionality, performance, and shorten the device lifetime.
- (2) A voltage of 2 V below PGND and 2 V above VIN can appear on this pin for ≤ 200 ns with a duty cycle of $\leq 0.01\%$.

7.2 ESD Ratings

		VALUE	UNIT
$V_{(ESD)}$	Electrostatic discharge	Human-body model (HBM), per ANSI/ESDA/JEDEC JS-001 ⁽¹⁾	± 1500
		Charged-device model (CDM), per ANSI/ESDA/JEDEC JS-002 ⁽²⁾	± 500

- (1) JEDEC document JEP155 states that 500-V HBM allows safe manufacturing with a standard ESD control process.
- (2) JEDEC document JEP157 states that 250-V CDM allows safe manufacturing with a standard ESD control process.

7.3 Recommended Operating Conditions

Limits apply over $T_J = -40^{\circ}\text{C}$ to 125°C (unless otherwise noted).

		MIN	NOM	MAX	UNIT
Input voltage	VIN (input voltage range after start-up)	3		36	V
Input voltage	VLDOIN			min (V_{VIN} , 12)	V
Output voltage	VOOUT ⁽¹⁾	1		6	V
Output current	IOOUT ⁽²⁾	0		4	A
Frequency	F _{SW} set by RT	200		2200	kHz
Input current	PG			2	mA
Output voltage	PG			16	V
T _J	Operating junction temperature	-40		125	°C
T _A	Operating ambient temperature	-40		105	°C

- (1) Under no conditions should the output voltage be allowed to fall below zero volts.
- (2) Maximum continuous DC current can be derated when operating with high switching frequency, high ambient temperature, or both. Refer to the *Typical Characteristics* section for details.

7.4 Thermal Information

THERMAL METRIC ⁽¹⁾		RDL (QFN)	UNIT
		20 PINS	
R _{θJA}	Junction-to-ambient thermal resistance (TLVM13660 EVM)	22.6	°C/W
R _{θJA}	Junction-to-ambient thermal resistance ⁽²⁾	33.1	°C/W
ψ _{JT}	Junction-to-top characterization parameter ⁽³⁾	1	°C/W
ψ _{JB}	Junction-to-board characterization parameter ⁽⁴⁾	12.3	°C/W

- (1) For more information about traditional and new thermal metrics, see the [Semiconductor and IC Package Thermal Metrics](#) application report.
- (2) The junction-to-ambient thermal resistance, R_{θJA}, applies to devices soldered directly to a 75-mm × 75-mm four-layer PCB with 2 oz. copper and natural convection cooling. Additional airflow and PCB copper area reduces R_{θJA}.
- (3) The junction-to-top board characterization parameter, ψ_{JT}, estimates the junction temperature, T_J, of a device in a real system, using a procedure described in JESD51-2A (section 6 and 7). $T_J = \psi_{JT} \times P_{DIS} + T_T$; where P_{DIS} is the power dissipated in the device and T_T is the temperature of the top of the device.
- (4) The junction-to-board characterization parameter, ψ_{JB}, estimates the junction temperature, T_J, of a device in a real system, using a procedure described in JESD51-2A (sections 6 and 7). $T_J = \psi_{JB} \times P_{DIS} + T_B$; where P_{DIS} is the power dissipated in the device and T_B is the temperature of the board 1mm from the device.

7.5 Electrical Characteristics

Limits apply over $T_J = -40^\circ\text{C}$ to 125°C , $V_{IN} = 24\text{ V}$, $V_{OUT} = 3.3\text{ V}$, $V_{LDOIN} = 5\text{ V}$, $F_{SW} = 800\text{ kHz}$ (unless otherwise noted). Minimum and maximum limits are specified through production test or by design. Typical values represent the most likely parametric norm and are provided for reference only.

PARAMETER		TEST CONDITIONS	MIN	TYP	MAX	UNIT
SUPPLY VOLTAGE						
V_{IN}	Input operating voltage range	Needed to start up (over the I_{OUT} range)	3.95		36	V
		Once operating (over the I_{OUT} range)	3		36	V
V_{IN_HYS}	Hysteresis ⁽¹⁾			1		V
I_{Q_VIN}	Input operating quiescent current (non-switching)	$T_A = 25^\circ\text{C}$, $V_{EN} = 3.3\text{ V}$, $V_{FB} = 1.5\text{ V}$		7		μA
I_{SDN_VIN}	VIN shutdown quiescent current	$V_{EN} = 0\text{ V}$, $T_A = 25^\circ\text{C}$		1		μA
ENABLE						
V_{EN_RISE}	EN voltage rising threshold		1.161	1.263	1.365	V
V_{EN_FALL}	EN voltage falling threshold			0.91		V
V_{EN_HYS}	EN voltage hysteresis		0.303	0.353	0.404	V
V_{EN_WAKE}	EN wake-up threshold		0.4			V
I_{EN}	Input current into EN (non-switching)	$V_{EN} = 3.3\text{ V}$, $V_{FB} = 1.5\text{ V}$		10		nA
t_{EN}	EN high to start of switching delay ⁽¹⁾			0.7		ms
VCC INTERNAL LDO						
V_{CC}	Internal LDO VCC voltage	$3.4\text{ V} \leq V_{VLDOIN} \leq 12.5\text{ V}$		3.3		V
		$V_{VLDOIN} = 3.1\text{ V}$, non-switching		3.1		V
V_{CC_UVLO}	VCC UVLO rising threshold	$V_{VLDOIN} < 3.1\text{ V}$ ⁽¹⁾		3.6		V
		$V_{IN} < 3.6\text{ V}$ ⁽²⁾		3.6		V
$V_{CC_UVLO_HYS}$	VCC UVLO hysteresis ⁽²⁾	Hysteresis below V_{CC_UVLO}		1.1		V
I_{VLDOIN}	Input current into VLDOIN pin (non-switching) ⁽³⁾	$V_{EN} = 3.3\text{ V}$, $V_{FB} = 1.5\text{ V}$		25	31	μA
FEEDBACK						
V_{OUT}	Adjustable output voltage range	Over the I_{OUT} range	1		6	V
V_{FB}	Feedback voltage	$T_A = 25^\circ\text{C}$, $I_{OUT} = 0\text{ A}$		1.0		V
V_{FB_ACC}	Feedback voltage accuracy	Over the V_{IN} range, $V_{OUT} = 1\text{ V}$, $I_{OUT} = 0\text{ A}$, $F_{SW} = 200\text{ kHz}$	-1%		+1%	
V_{FB}	Load regulation	$T_A = 25^\circ\text{C}$, $0\text{ A} \leq I_{OUT} \leq 6\text{ A}$		0.1%		
V_{FB}	Line regulation	$T_A = 25^\circ\text{C}$, $I_{OUT} = 0\text{ A}$, $4\text{ V} \leq V_{IN} \leq 36\text{ V}$		0.1%		
I_{FB}	Input current into FB	$V_{FB} = 1\text{ V}$		10		nA
CURRENT						
I_{OUT}	Output current	$T_A = 25^\circ\text{C}$	0		4	A
I_{OCL}	Output overcurrent (DC) limit threshold			5.9		A
I_{L_HS}	High-side switch current limit	Duty cycle approaches 0%	6.0	7.0	8.1	A
I_{L_LS}	Low-side switch current limit		4.0	4.8	5.4	A
I_{L_NEG}	Negative current limit			-3		A
V_{HICCUP}	Ratio of FB voltage to in-regulation FB voltage to enter hiccup	Not during soft start		40%		
t_W	Short circuit wait time ("hiccup" time before soft start) ⁽¹⁾			80		ms
SOFT START						
t_{SS}	Time from first SW pulse to V_{FB} at 90%	$V_{IN} \geq 4.2\text{ V}$	3.5	5	7	ms
t_{SS2}	Time from first SW pulse to release of FPWM lockout if output not in regulation ⁽¹⁾	$V_{IN} \geq 4.2\text{ V}$	9.5	13	17	ms
POWER GOOD						
PG_{OV}	PG upper threshold – rising	% of V_{OUT} setting	105%	107%	110%	
PG_{UV}	PG lower threshold – falling	% of V_{OUT} setting	92%	94%	96.5%	
PG_{HYS}	PG threshold hysteresis (rising and falling)	% of V_{OUT} setting		1.3%		
$V_{IN_PG_VALID}$	Input voltage for valid PG output	46- μA pullup, $V_{EN} = 0\text{ V}$	1.0			V
V_{PG_LOW}	PG low-level output voltage	2-mA pullup to PG pin, $V_{EN} = 3.3\text{ V}$			0.4	V

Limits apply over $T_J = -40^{\circ}\text{C}$ to 125°C , $V_{IN} = 24\text{ V}$, $V_{OUT} = 3.3\text{ V}$, $V_{LDOIN} = 5\text{ V}$, $F_{SW} = 800\text{ kHz}$ (unless otherwise noted). Minimum and maximum limits are specified through production test or by design. Typical values represent the most likely parametric norm and are provided for reference only.

PARAMETER		TEST CONDITIONS	MIN	TYP	MAX	UNIT
I_{PG}	Input current into PG pin when open drain output is high	$V_{PG} = 3.3\text{ V}$		10		nA
I_{OV}	Pulldown current at the SW node during an overvoltage condition			0.5		mA
$t_{PG_FLT_RISE}$	Delay time to PG high signal		1.5	2.0	2.5	ms
$t_{PG_FLT_FALL}$	Glitch filter time constant for PG function			120		μs
SWITCHING FREQUENCY						
f_{SW_RANGE}	Switching frequency range by RT or SYNC		200		2200	kHz
f_{SW_RT1}	Default switching frequency by R_{RT}	$R_{RT} = 66.5\text{ k}\Omega$	180	200	220	kHz
f_{SW_RT2}	Default switching frequency by R_{RT}	$R_{RT} = 5.76\text{ k}\Omega$	1980	2200	2420	kHz
SYNCHRONIZATION						
t_B	Blanking of EN after rising or falling edges ⁽¹⁾		4		28	μs
POWER STAGE						
V_{BOOT_UVLO}	Voltage on CBOOT pin relative to SW that turns off the high-side switch			2.1		V
$t_{ON(min)}$	Minimum ON pulse width ⁽¹⁾	$V_{OUT} = 1\text{ V}$, $I_{OUT} = 1\text{ A}$, RBOOT shorted to CBOOT		55	70	ns
$t_{ON(max)}$	Maximum ON pulse width ⁽¹⁾			9		μs
$t_{OFF(min)}$	Minimum OFF pulse width	$V_{IN} = 4\text{ V}$, $I_{OUT} = 1\text{ A}$, RBOOT shorted to CBOOT		65	85	ns
THERMAL SHUTDOWN						
T_{SHD}	Thermal shutdown threshold ⁽¹⁾	Temperature rising	158	168	180	$^{\circ}\text{C}$
$T_{SHD-HYS}$	Thermal shutdown hysteresis ⁽¹⁾			10		$^{\circ}\text{C}$

- (1) Parameter specified by design, statistical analysis and production testing of correlated parameters. Not production tested.
- (2) Production tested with $V_{IN} = 3\text{ V}$.
- (3) This is the current used by the device while not switching, open loop, with FB pulled to +5% of nominal. It does not represent the total input current to the system while regulating.

7.6 System Characteristics

The following specifications apply only to the typical applications circuit, with nominal component values. Specifications in the typical (TYP) column apply to $T_J = 25^{\circ}\text{C}$ only. These specifications are not ensured by production testing.

PARAMETER		TEST CONDITIONS	MIN	TYP	MAX	UNIT
SUPPLY						
I_{IN}	Input supply current when in regulation	$V_{IN} = V_{EN} = 24\text{ V}$, $V_{OUT} = V_{LDOIN} = 3.3\text{ V}$, $F_{SW} = 750\text{ kHz}$, $I_{OUT} = 0\text{ A}$		15		mA
OUTPUT VOLTAGE						
ΔV_{OUT1}	Load regulation	$V_{IN} = 24\text{ V}$, $V_{OUT} = 3.3\text{ V}$, $I_{OUT} = 0.1\text{ A}$ to 4 A		1		mV
ΔV_{OUT2}	Line regulation	$V_{OUT} = 3.3\text{ V}$, $V_{IN} = 4\text{ V}$ to 36 V , $I_{OUT} = 4\text{ A}$		1		mV
ΔV_{OUT3}	Load transient	$V_{IN} = 24\text{ V}$, $V_{OUT} = 3.3\text{ V}$, $I_{OUT} = 1\text{ A}$ to 4 A at $1\text{ A}/\mu\text{s}$, $C_{OUT(derated)} = 50\text{ }\mu\text{F}$		100		mV
EFFICIENCY						
η	Efficiency	$V_{IN} = 12\text{ V}$, $V_{OUT} = V_{LDOIN} = 3.3\text{ V}$, $I_{OUT} = 4\text{ A}$, $F_{SW} = 750\text{ kHz}$		92.1%		
η	Efficiency	$V_{IN} = 24\text{ V}$, $V_{OUT} = V_{LDOIN} = 3.3\text{ V}$, $I_{OUT} = 4\text{ A}$, $F_{SW} = 750\text{ kHz}$		91%		
η	Efficiency	$V_{IN} = 12\text{ V}$, $V_{OUT} = V_{LDOIN} = 5\text{ V}$, $I_{OUT} = 4\text{ A}$, $F_{SW} = 1\text{ MHz}$		94.3%		
η	Efficiency	$V_{IN} = 24\text{ V}$, $V_{OUT} = V_{LDOIN} = 5\text{ V}$, $I_{OUT} = 4\text{ A}$, $F_{SW} = 1\text{ MHz}$		93%		
η	Efficiency	$V_{IN} = 24\text{ V}$, $V_{OUT} = V_{LDOIN} = 12\text{ V}$, $I_{OUT} = 4\text{ A}$, $F_{SW} = 2\text{ MHz}$		95.6%		

7.7 Typical Characteristics

$V_{IN} = 24\text{ V}$, unless otherwise specified

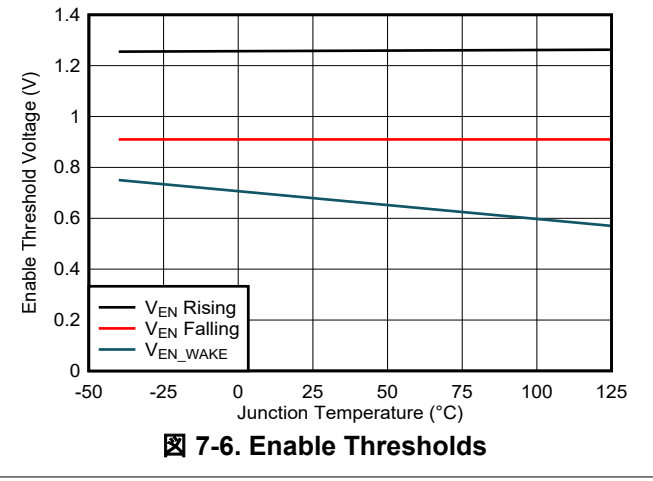
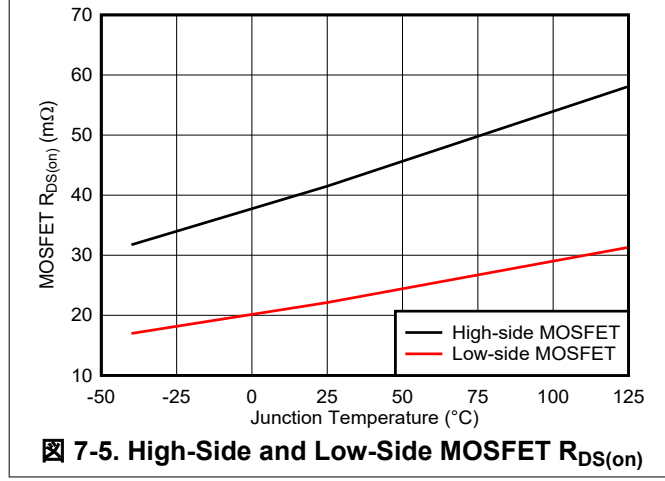
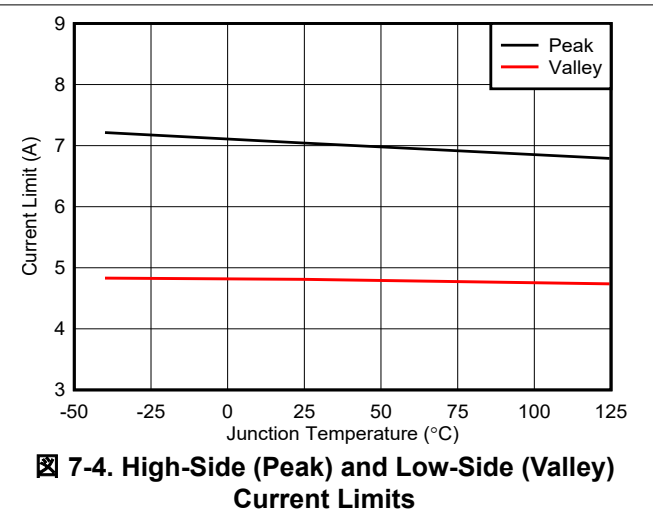
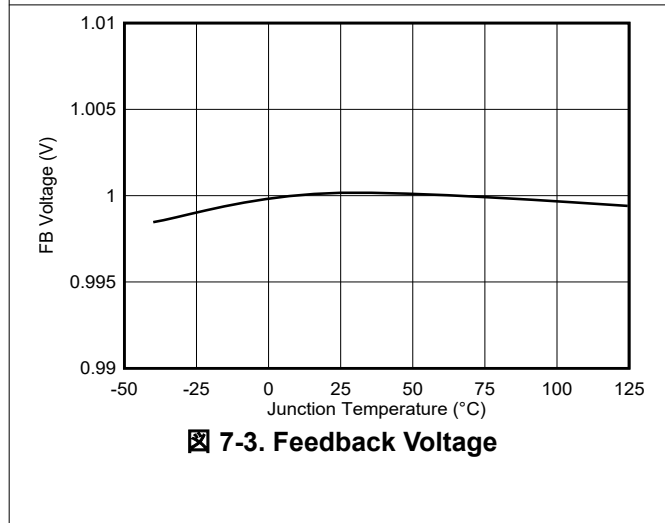
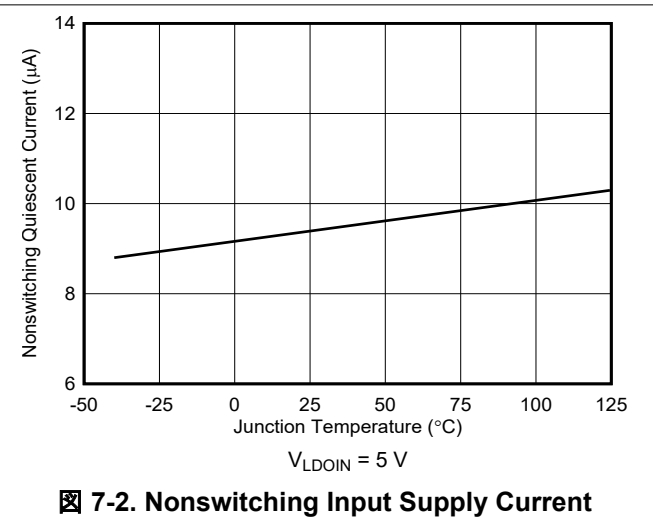
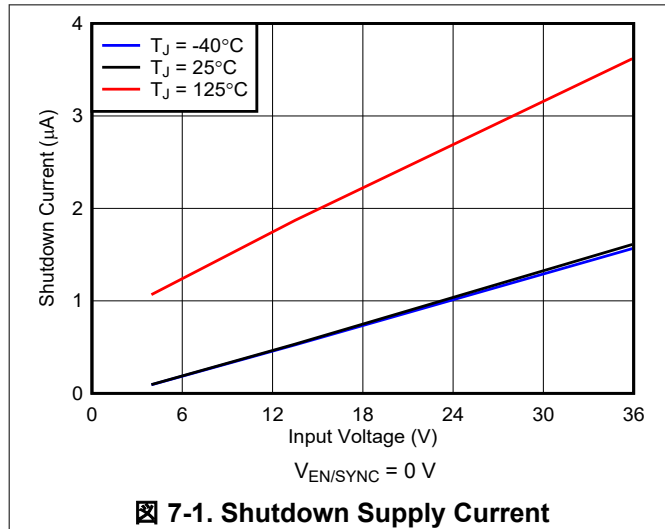

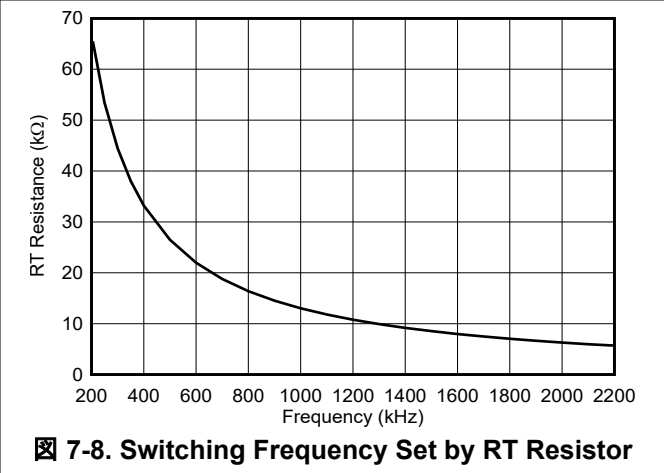
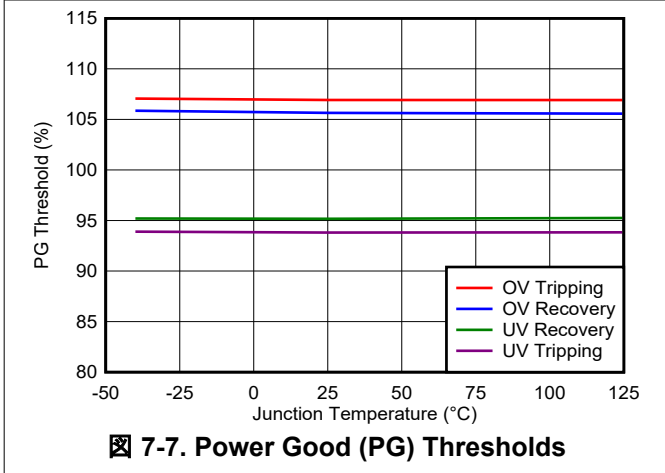

7.8 Typical Characteristics ($V_{IN} = 12\text{ V}$)

Unless otherwise indicated, $T_A = 25^\circ\text{C}$, VLDOIN is tied to VOUT (except for $V_{OUT} = 2.5\text{ V}$), and the module is soldered to a 76-mm × 63-mm, 4-layer PCB. The SOA curves are taken with $T_{J(max)} = 125^\circ\text{C}$ and $T_{A(max)} = 105^\circ\text{C}$. Refer to [セクション 9.2](#) for circuit designs.

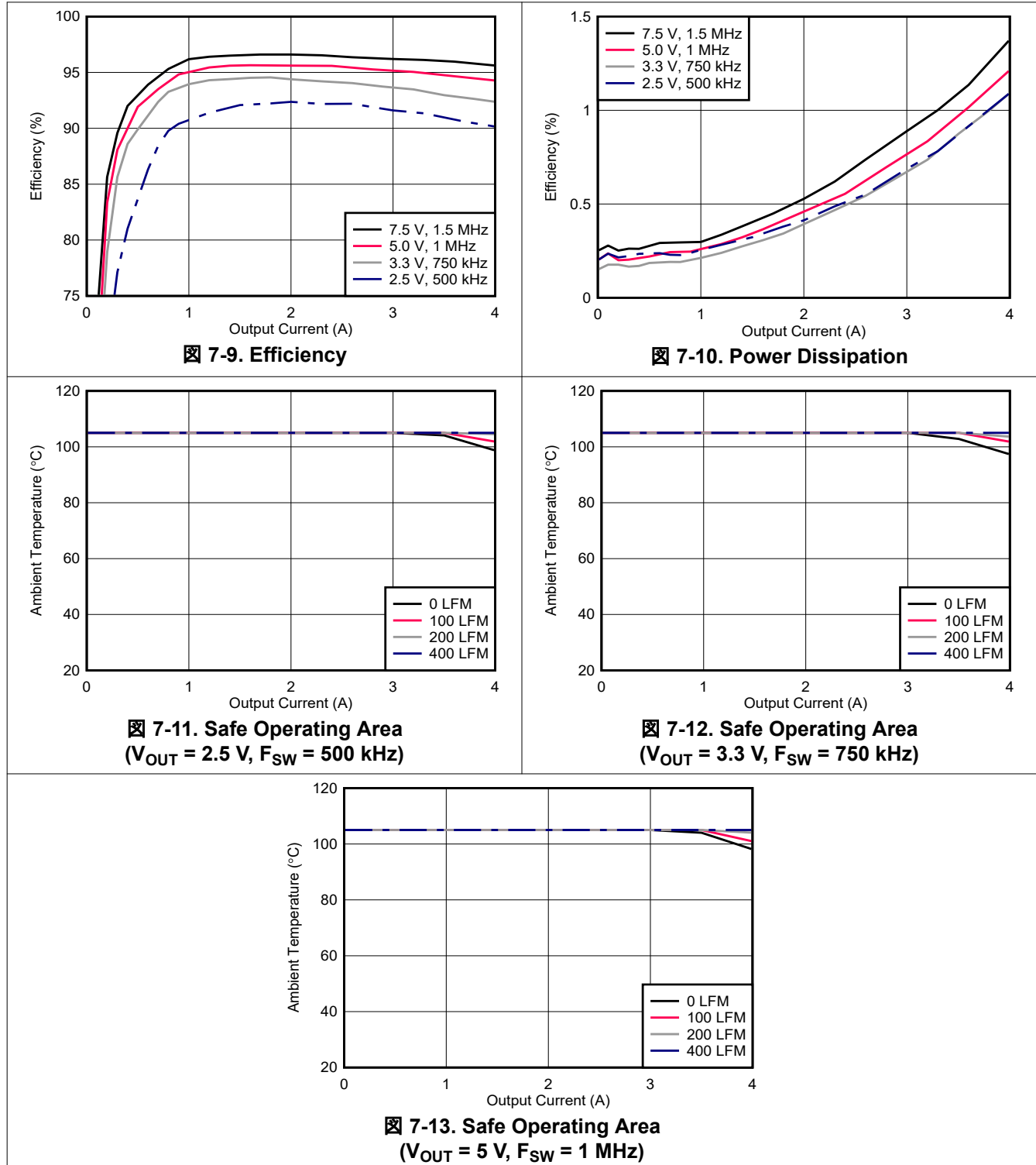

7.9 Typical Characteristics ($V_{IN} = 24\text{ V}$)

Unless otherwise indicated, $T_A = 25^\circ\text{C}$, VLDOIN is tied to VOUT (except for $V_{OUT} = 2.5\text{ V}$), and the module is soldered to a 76-mm × 63-mm, 4-layer PCB. The SOA curves are taken with $T_{J(max)} = 125^\circ\text{C}$ and $T_{A(max)} = 105^\circ\text{C}$. Refer to [セクション 9.2](#) for circuit designs.

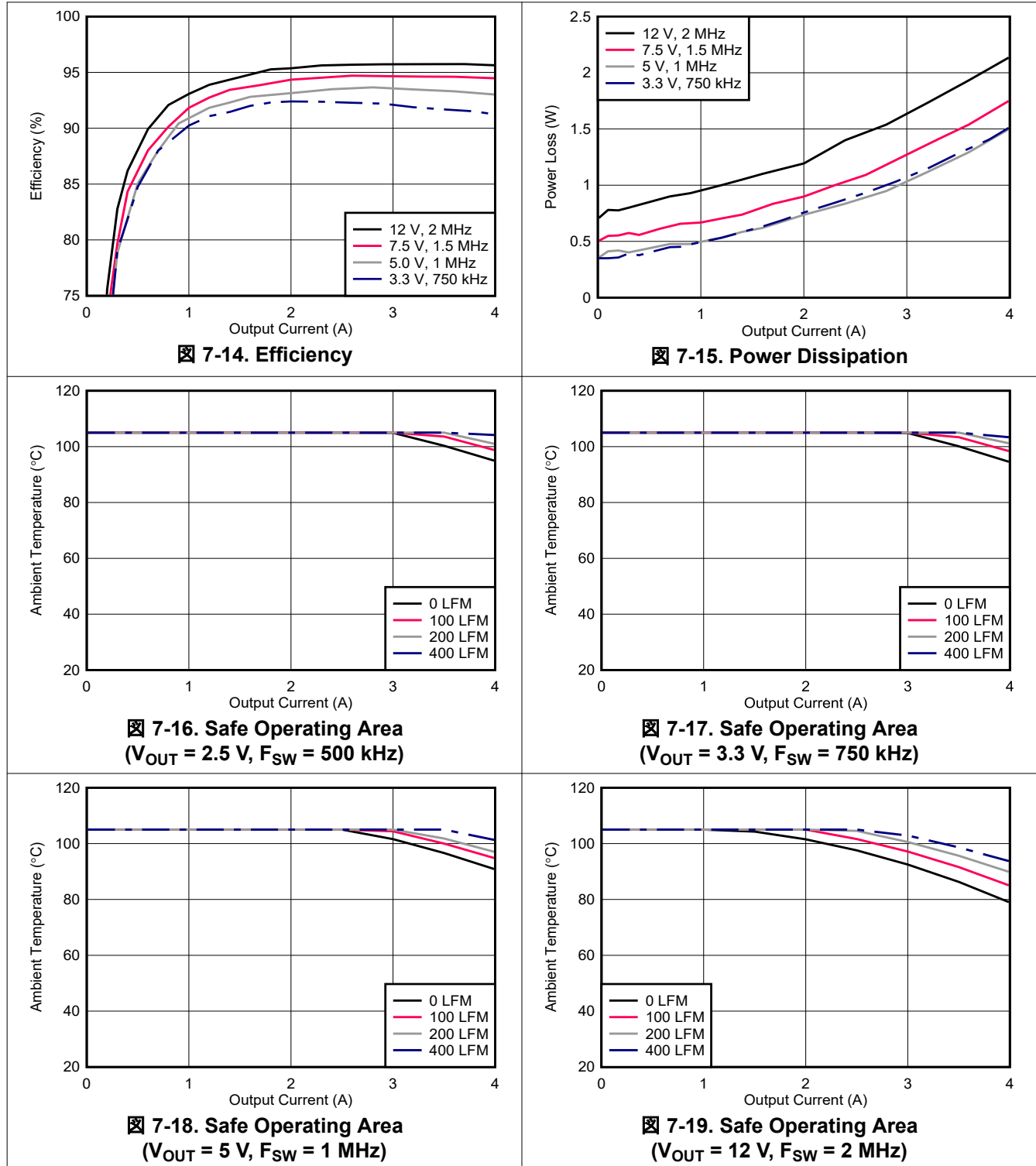

8.3 Feature Description

8.3.1 Input Voltage Range (VIN1, VIN2)

With a steady-state input voltage range from 3 V to 36 V, the TLVM13640 module is intended for step-down conversions from typical 12-V, 24-V, and 28-V input supply rails. The schematic circuit in [Figure 8-1](#) shows all the necessary components to implement a TLVM13640-based buck regulator using a single input supply.

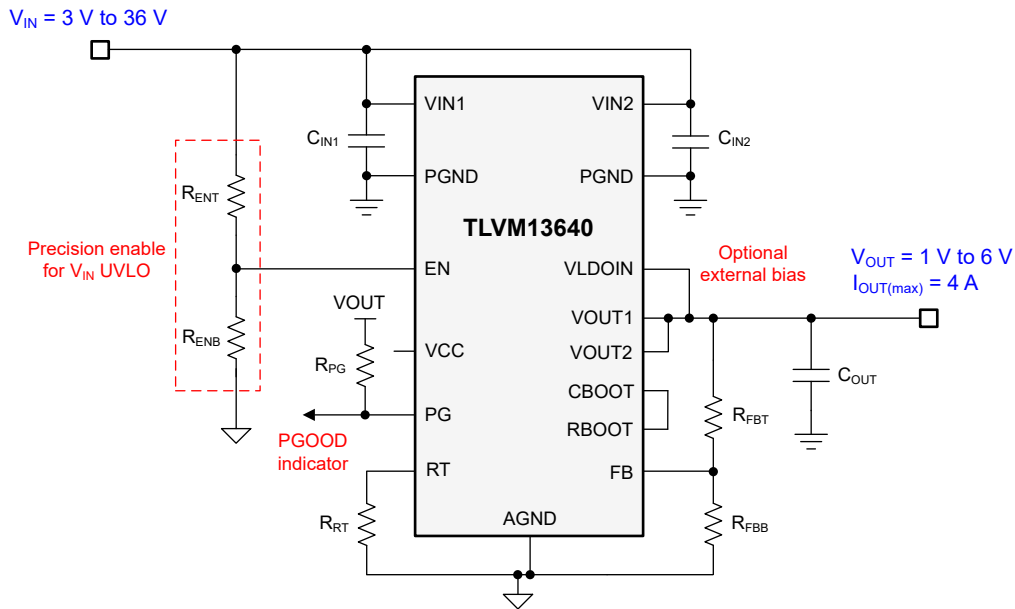

Figure 8-1. TLVM13640 Schematic Diagram with Input Voltage Operating Range of 3 V to 36 V

The minimum input voltage required for start-up is 3.95 V. Take extra care to make sure that the voltage at the VIN pins of the module (VIN1 and VIN2) does not exceed the absolute maximum voltage rating of 42 V during line or load transient events. Voltage ringing at the VIN pins that exceeds the [absolute maximum ratings](#) can damage the IC.

8.3.2 Adjustable Output Voltage (FB)

The TLVM13640 has an adjustable output voltage range from 1 V up to a maximum of 6 V or slightly less than V_{IN} , whichever is lower. Setting the output voltage requires two feedback resistors, designated as R_{FBT} and R_{FBB} in [Figure 8-1](#). The reference voltage at the FB pin is set at 1 V with a feedback system accuracy over the full junction temperature range of $\pm 1\%$. The junction temperature range for the device is -40°C to 125°C .

Calculate the value for R_{FBT} using [Equation 1](#) based on a recommended value for R_{FBB} of 10 k Ω .

$$R_{FBT} [\text{k}\Omega] = R_{FBB} [\text{k}\Omega] \cdot \left(\frac{V_{OUT} [\text{V}]}{1\text{V}} - 1 \right) \quad (1)$$

[Table 8-1](#) lists the standard resistor values for several output voltages and the recommended switching frequency range to maintain reasonable peak-to-peak inductor ripple current. This table also includes the minimum required output capacitance for each output voltage setting to maintain stability. The capacitances as listed represent *effective* values for ceramic capacitors derated for DC bias voltage and temperature. Furthermore, place a feedforward capacitor, C_{FF} , in parallel with R_{FBT} to increase the phase margin when the output capacitance is close to the minimum recommended value.

表 8-1. Standard R_{F_{BT}} Values, Recommended F_{SW} Range and Minimum C_{OUT}

V _{OUT} (V)	R _{F_{BT}} (kΩ) ⁽¹⁾	Suggested F _{SW} Range (kHz)	C _{OUT(min)} (μF) (Effective)	C _{FF} (pF)	V _{OUT} (V)	R _{F_{BT}} (kΩ) ⁽¹⁾	Suggested F _{SW} Range (MHz)	C _{OUT(min)} (μF) (Effective)	C _{FF} (pF)
1	Short	300 to 500	300	–	2.5	15	650 to 900	65	68
1.2	2	400 to 600	200	–	3.3	23.2	700 to 950	40	47
1.8	8.06	500 to 700	120	100	5	40.2	0.8 to 1.2	25	22

(1) R_{F_{BB}} = 10 kΩ

Note that higher feedback resistances consume less DC current. However, an upper R_{F_{BT}} resistor value higher than 1 MΩ renders the feedback path more susceptible to noise. Higher feedback resistances generally require more careful layout of the feedback path. It is important to locate the feedback resistors close to the FB and AGND pins, keeping the feedback trace as short as possible (and away from noisy areas of the PCB). See [セクション 11.2](#) guidelines for more detail.

8.3.3 Input Capacitors

Input capacitors are necessary to limit the input ripple voltage to the module due to switching frequency AC currents. TI recommends using ceramic capacitors to provide low impedance and high RMS current rating over a wide temperature range. [式 2](#) gives the input capacitor RMS current. The highest input capacitor RMS current occurs at D = 0.5, at which point, the RMS current rating of the capacitors should be greater than half the output current.

$$I_{CIN,rms} = \sqrt{D \cdot \left(I_{OUT}^2 \cdot (1-D) + \frac{\Delta I_L^2}{12} \right)} \quad (2)$$

where

- D = V_{OUT} / V_{IN} is the module duty cycle.

Ideally, the DC and AC components of input current to the buck stage are provided by the input voltage source and the input capacitors, respectively. Neglecting inductor ripple current, the input capacitors source current of amplitude (I_{OUT} – I_{IN}) during the D interval and sink I_{IN} during the 1 – D interval. Thus, the input capacitors conduct a square-wave current of peak-to-peak amplitude equal to the output current. The resultant capacitive component of AC ripple voltage is a triangular waveform. Together with the ESR-related ripple component, [式 3](#) gives the peak-to-peak ripple voltage amplitude:

$$\Delta V_{IN} = \frac{I_{OUT} \cdot D \cdot (1-D)}{F_{SW} \cdot C_{IN}} + I_{OUT} \cdot R_{ESR} \quad (3)$$

[式 4](#) gives the input capacitance required for a particular load current:

$$C_{IN} \geq \frac{D \cdot (1-D) \cdot I_{OUT}}{F_{SW} \cdot (\Delta V_{IN} - R_{ESR} \cdot I_{OUT})} \quad (4)$$

where

- ΔV_{IN} is the input voltage ripple specification.

The TLVM13640 requires a minimum of two 10-μF ceramic input capacitors, preferably with X7R or X7S dielectric and in 1206 or 1210 footprint. Additional capacitance can be required for applications to meet conducted EMI specifications, such as CISPR 11 or CISPR 32.

[表 8-2](#) includes a preferred list of capacitors by vendor. To minimize the parasitic inductance in the switching loops, position the ceramic input capacitors in a symmetrical [layout](#) close to the VIN1 and VIN2 pins and connect the capacitor return terminals to the PGND pins using a copper ground plane under the module.

表 8-2. Recommended Ceramic Input Capacitors

Vendor ⁽¹⁾	Dielectric	Part Number	Case Size	Capacitance (μF) ⁽²⁾	Rated Voltage (V)
TDK	X7R	C3216X7R1H106K160AC	1206	10	50
Murata	X7S	GCM32EC71H106KA03K	1210	10	50
AVX	X7R	12105C106MAT2A	1210	10	50
Murata	X7R	GRM32ER71H106KA12L	1210	10	50

- (1) Consult capacitor suppliers regarding availability, material composition, RoHS and lead-free status, and manufacturing process requirements for any capacitors identified in this table. See the [Third-Party Products Disclaimer](#).
- (2) Nameplate capacitance values (the effective values are lower based on the applied DC voltage and temperature).

As discussed in [セクション 10](#), an electrolytic bulk capacitance (68 μF to 100 μF) provides low-frequency filtering and parallel damping to mitigate the effects of input parasitic inductance resonating with the low-ESR, high-Q ceramic input capacitors.

8.3.4 Output Capacitors

[表 8-1](#) lists the TLVM13640 minimum amount of required output capacitance. The effects of DC bias and temperature variation must be considered when using ceramic capacitance. For ceramic capacitors in particular, the package size, voltage rating, and dielectric material contribute to differences between the standard rated value and the actual effective value of the capacitance.

When including additional capacitance above $C_{OUT(min)}$, the capacitance can be ceramic type, low-ESR polymer type, or a combination of the two. See [表 8-3](#) for a preferred list of output capacitors by vendor.

表 8-3. Recommended Ceramic Output Capacitors

Vendor ⁽¹⁾	Dielectric	Part Number	Case Size	Capacitance (μF) ⁽²⁾	Voltage (V)
Murata	X7R	GRM31CZ71C226ME15L	1206	22	16
TDK	X7R	C3225X7R1C226M250AC	1210	22	16
Murata	X7R	GRM32ER71C226KEA8K	1210	22	16
TDK	X6S	C3216X6S1E226M160AC	1206	22	25
AVX	X7R	12103C226KAT4A	1210	22	25
Murata	X7R	GRM32ER71E226ME15L	1210	22	25
AVX	X7R	1210ZC476MAT2A	1210	47	10
Murata	X7R	GRM32ER71A476ME15L	1210	47	10
Murata	X6S	GRM32EC81C476ME15L	1210	47	16
TDK	X6S	C3216X6S0G107M160AC	1206	100	4
Murata	X6T	GRM31CD80J107MEA8L	1206	100	6.3
Murata	X7S	GRM32EC70J107ME15L	1210	100	6.3

- (1) Consult capacitor suppliers regarding availability, material composition, RoHS and lead-free status, and manufacturing process requirements for any capacitors identified in the table. See the [Third-Party Products Disclaimer](#).
- (2) Nameplate capacitance values (the effective values are lower based on the applied DC voltage and temperature)

8.3.5 Switching Frequency (RT)

Connect a resistor, designated as R_{RT} in [図 8-1](#), between RT and AGND to set the switching frequency within the range of 200 kHz to 2.2 MHz. Use [式 5](#) or refer to [図 7-8](#) to calculate R_{RT} for a desired frequency.

$$R_{RT} [k\Omega] = \frac{13.46}{F_{SW} [MHz]} - 0.44 \quad (5)$$

Refer to [表 8-1](#) or use the simplified expression in [式 6](#) to find a switching frequency that sets an inductor ripple current of 30% to 50% of the 4-A module current rating at nominal input voltage:

$$F_{SW} [MHz] = 0.25 \cdot V_{OUT} [V] \cdot \left(1 - \frac{V_{OUT} [V]}{V_{IN(nom)}} [V]\right) \quad (6)$$

where

- $V_{IN(nom)}$ and V_{OUT} are the nominal input voltage (typically 12 V or 24 V) and output voltage of the application, respectively.

Note that a resistor value outside of the recommended range can cause the module to shut down. This prevents unintended operation if the RT pin is shorted to ground or left open.

8.3.6 Precision Enable and Input Voltage UVLO (EN)

The EN pin provides precision ON and OFF control for the TLVM13640. Once the EN pin voltage exceeds the rising threshold and V_{IN} is above its minimum turn-on threshold, the device starts operation. The simplest way to enable the TLVM13640 is to connect EN directly to V_{IN} . This allows the TLVM13640 to start up when V_{IN} is within its valid operating range. However, many applications benefit from the use of an enable divider network as shown in [Figure 8-1](#), which establishes a precision input undervoltage lockout (UVLO). This can be used for sequencing, to prevent re-triggering the device when used with long input cables, or to reduce the occurrence of deep discharge of a battery power source. An external logic signal can also be used to drive the enable input to toggle the output on and off and for system sequencing or protection.

Calculate R_{ENB} using [Equation 7](#):

$$R_{ENB} [k\Omega] = R_{ENT} [k\Omega] \cdot \left(\frac{V_{EN_RISE} [V]}{V_{IN(on)} [V] - V_{EN_RISE} [V]} \right) \quad (7)$$

where

- A typical value for R_{ENT} is 100 k Ω .
- V_{EN_RISE} is enable rising threshold voltage of 1.263 V (typical).
- $V_{IN(on)}$ is the desired start-up input voltage.

8.3.7 Power Good Monitor (PG)

The TLVM13640 provides a power-good status signal to indicate when the output voltage is within a regulation window of 94% to 107%. The PG voltage goes low when the feedback (FB) voltage is outside of the specified PGOOD thresholds (see [Figure 7-7](#)). This can occur during current limit and thermal shutdown, as well as when disabled and during start-up.

PG is an open-drain output, requiring an external pullup resistor to a DC supply, such as V_{CC} or V_{OUT} . To limit current supplied by V_{CC} , the recommended range of pullup resistance is 20 k Ω to 100 k Ω . A 120- μ s deglitch filter prevents false flag operation for short excursions of the output voltage, such as during line and load transients. When EN is pulled low, PG is forced low and remains valid as long as the input voltage is above 1 V (typical). Use the PG signal for start-up sequencing of downstream regulators, as shown in [Figure 8-2](#), or for fault protection and output monitoring.

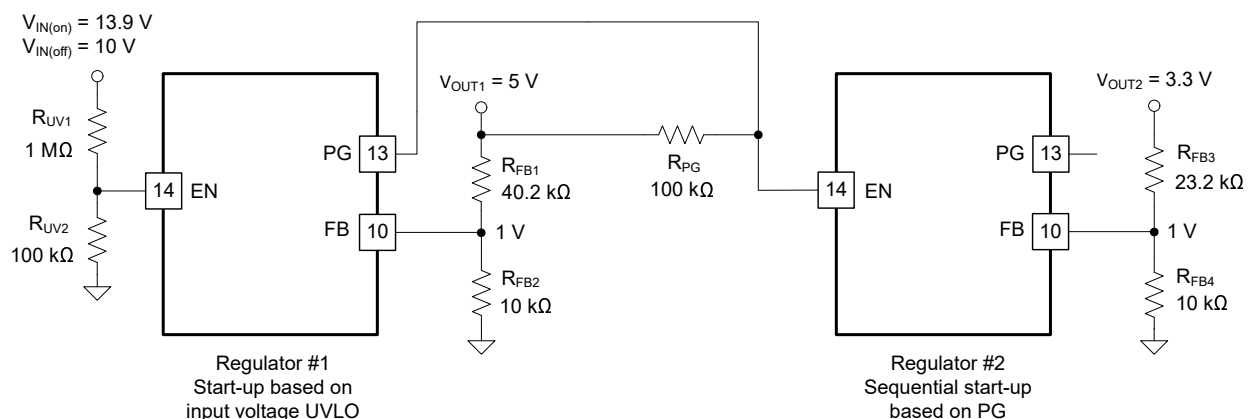

Figure 8-2. TLVM13640 Sequencing Implementation Using PG and EN

8.3.8 Adjustable Switch-Node Slew Rate (RBOOT, CBOOT)

Adjust the switch-node slew rate of the TLVM13640 to slow the switch-node voltage rise time and improve EMI performance at high frequencies. However, slowing the rise time decreases efficiency. Care must be taken to balance the improved EMI versus the decreased efficiency.

Internal to the module, a 100-Ω bootstrap resistor connects between the RBOOT and CBOOT pins as shown in [Figure 8-3](#). Leaving these pins open incorporates the 100-Ω resistor in the bootstrap circuit, slowing the switch voltage slew rate and optimizing EMI. However, if improved EMI is not required, connect RBOOT to CBOOT to short the internal resistor, thus resulting in the highest efficiency. Place a resistor across RBOOT and CBOOT to allow adjustment of the internal resistance to balance EMI and efficiency performance.

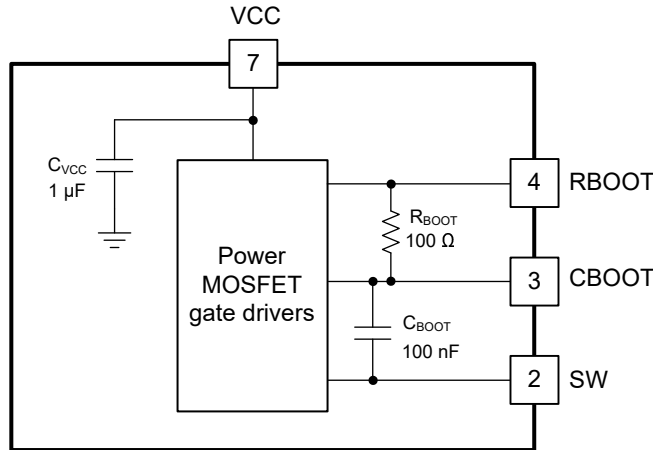

Figure 8-3. Internal BOOT Resistor

8.3.9 Bias Supply Regulator (VCC, VLDOIN)

VCC is the output of the internal LDO subregulator used to supply the control circuits of the TLVM13640. The nominal VCC voltage is 3.3 V. The VLDOIN pin is the input to the internal LDO. Connect this input to V_{OUT} to provide the lowest possible input supply current. If the VLDOIN voltage is less than 3.1 V, VIN1 and VIN2 directly power the internal LDO.

To prevent unsafe operation, VCC has UVLO protection that prevents switching if the internal voltage is too low. See V_{CC_UVLO} and V_{CC_UVLO_HYS} in the [Electrical Characteristics](#).

VCC must not be used to power external circuitry. Do not load VCC or short it to ground. VLDOIN is an optional input to the internal LDO. Connect an optional high quality 0.1-μF to 1-μF capacitor from VLDOIN to AGND for improved noise immunity.

The LDO provides the VCC voltage from one of two inputs: V_{IN} or VLDOIN. When VLDOIN is tied to ground or below 3.1 V, the LDO derives power from V_{IN}. The LDO input becomes VLDOIN when VLDOIN is tied to a voltage above 3.1 V. The VLDOIN voltage must not exceed both V_{IN} and 12 V.

[Equation 8](#) specifies the LDO power loss reduction as:

$$P_{\text{LDO-LOSS}} = I_{\text{LDO}} \times (V_{\text{IN-LDO}} - V_{\text{VCC}}) \quad (8)$$

The VLDOIN input provides an option to supply the LDO with a lower voltage than V_{IN}, thus minimizing the LDO input voltage relative to VCC and reducing power loss. For example, if the LDO current is 10 mA at 1 MHz with V_{IN} = 24 V and V_{OUT} = 5 V, the LDO power loss with VLDOIN tied to ground is 10 mA × (24 V – 3.3 V) = 207 mW, while the loss with VLDOIN tied to V_{OUT} is equal to 10 mA × (5 V – 3.3 V) = 17 mW – a reduction of 190 mW.

[Figure 8-4](#) and [Figure 8-5](#) show typical efficiency plots with and without VLDOIN connected to VOUT.

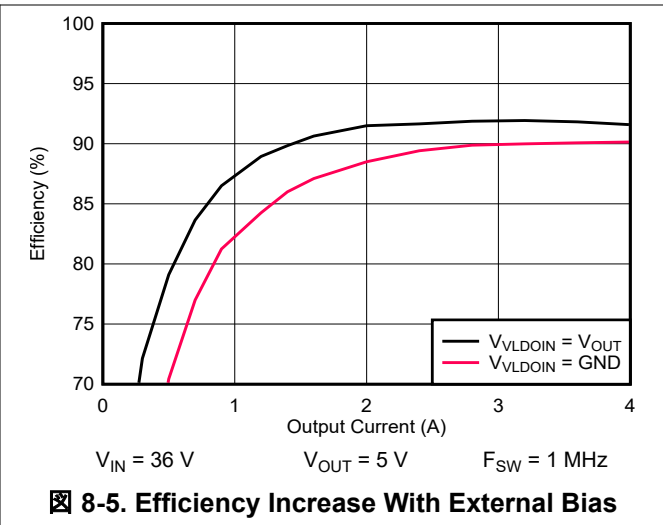
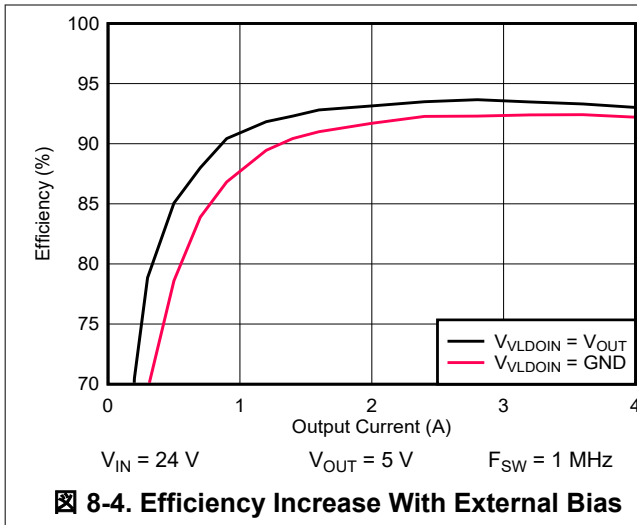

8.3.10 Overcurrent Protection (OCP)

The TLVM13640 is protected from overcurrent conditions using cycle-by-cycle current limiting of the peak inductor current. The current is compared every switching cycle to the current limit threshold. During an overcurrent condition, the output voltage decreases.

The TLVM13640 employs hiccup overcurrent protection if there is an extreme overload. In hiccup mode, the TLVM13640 module is shut down and kept off for 80 ms (typical) before a restart is attempted. If an overcurrent or short-circuit fault condition still exists, hiccup repeats until the fault condition is removed. Hiccup mode reduces power dissipation under severe overcurrent conditions, thus preventing overheating and potential damage to the device. Once the fault is removed, the module automatically recovers and returns to normal operation.

8.3.11 Thermal Shutdown

Thermal shutdown is an integrated self-protection used to limit junction temperature and prevent damage related to overheating. Thermal shutdown turns off the device when the junction temperature exceeds 168°C (typical) to prevent further power dissipation and temperature rise. Junction temperature decreases after shutdown, and the TLVM13640 attempts to restart when the junction temperature falls to 158°C (typical).

8.4 Device Functional Modes

8.4.1 Shutdown Mode

The EN pin provides ON and OFF control for the TLVM13640. When V_{EN} is below approximately 0.4 V, the device is in shutdown mode. Both the internal LDO and the switching regulator are off. The quiescent current in shutdown mode drops to 0.6 μ A (typical). The TLVM13640 also employs internal undervoltage protection. If the input voltage is below its UV threshold, the regulator remains off.

8.4.2 Standby Mode

The internal LDO for the VCC bias supply has a lower enable threshold than the regulator itself. When V_{EN} is above 1.1 V (maximum) and below the precision enable threshold of 1.263 V (typical), the internal LDO is on and regulating. The precision enable circuitry is turned on once the internal V_{CC} is above its UVLO threshold. The switching action and voltage regulation are not enabled until V_{EN} rises above the precision enable threshold.

8.4.3 Active Mode

The TLVM13640 is in active mode when V_{VCC} and V_{EN} are above their relevant thresholds and no fault conditions are present. The simplest way to enable operation is to connect EN to V_{IN} , which allows self start-up when the applied input voltage exceeds the minimum start-up voltage.

9 Applications and Implementation

Note

Information in the following applications sections is not part of the TI component specification, and TI does not warrant its accuracy or completeness. TI's customers are responsible for determining suitability of components for their purposes, as well as validating and testing their design implementation to confirm system functionality.

9.1 Application Information

The TLVM13640 synchronous buck module requires only a few external components to convert from a wide range of supply voltages to a fixed output voltage at an output current up to 4 A. To expedite and streamline the process of designing of a TLVM13640-based regulator, a comprehensive TLVM13640 [quickstart calculator](#) is available by download to assist the system designer with component selection for a given application.

9.2 Typical Applications

For the circuit schematic, bill of materials, PCB layout files, and test results of a TLVM13640-powered implementation, see the [TLVM13660 EVM](#).

9.2.1 Design 1 – High-Efficiency 4-A Synchronous Buck Regulator for Industrial Applications

Figure 9-1 shows the schematic diagram of a 5-V, 6-A buck regulator with a switching frequency of 1 MHz. In this example, the target half-load and full-load efficiencies are 93.2% and 93%, respectively, based on a nominal input voltage of 24 V that ranges from 9 V to 36 V. A resistor R_{RT} of 13 k Ω sets the free-running switching frequency at 1 MHz. An optional SYNC input signal allows adjustment of the switching frequency from 700 kHz to 1.4 MHz for this specific application.

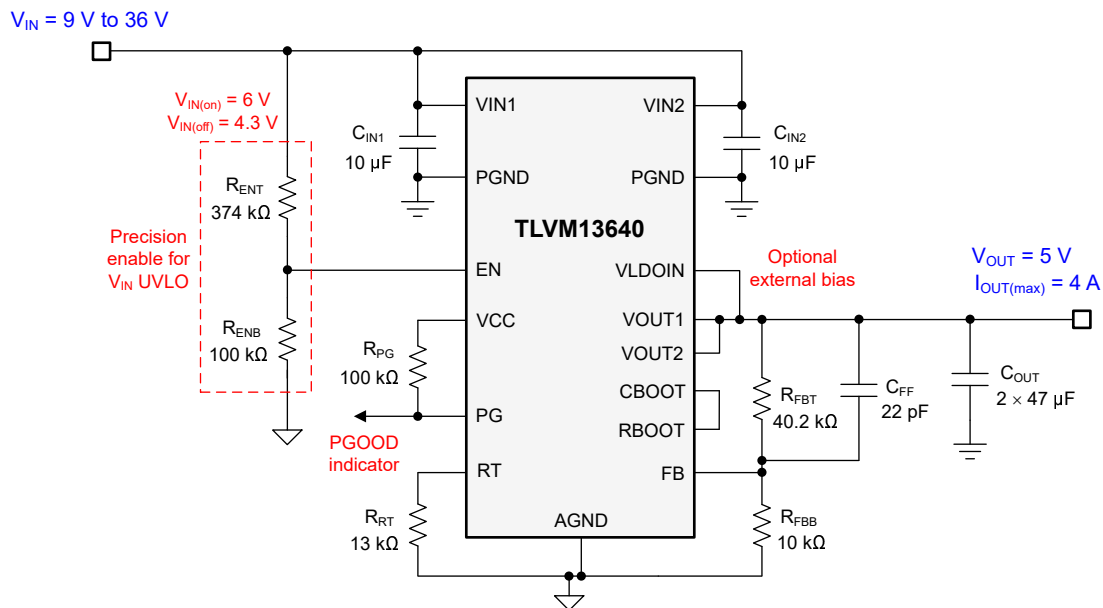

Figure 9-1. Circuit Schematic

9.2.1.1 Design Requirements

Table 9-1 shows the intended input, output, and performance parameters for this application example. Note that if the input voltage decreases below approximately 5.5 V, the regulator operates in dropout with the output voltage below its 5-V setpoint.

表 9-1. Design Parameters

Design Parameter	Value
Input voltage range	9 V to 36 V
Input voltage UVLO turn on, off	6 V, 4.3 V
Output voltage	5 V
Maximum output current	4 A
Switching frequency	1 MHz
Output voltage regulation	±1%
Module shutdown current	< 1 μA

表 9-2 gives the selected buck module power-stage components with availability from multiple vendors. This design uses an all-ceramic output capacitor implementation.

表 9-2. List of Materials for Application Circuit 1

Reference Designator	Qty	Specification	Manufacturer ⁽¹⁾	Part Number
C _{IN1} , C _{IN2}	2	10 μF, 50 V, X7R, 1210, ceramic	Taiyo Yuden	UMJ325KB7106KMHT
			TDK	CNA6P1X7R1H106K
		10 μF, 50 V, X7S, 1210, ceramic	Murata	GCM32EC71H106KA03
			TDK	CGA6P3X7S1H106M
C _{OUT1} , C _{OUT2}	2	47 μF, 6.3 V, X7R, 1210, ceramic	Murata	GRM32ER70J476ME20K
			AVX	12106C476MAT2A
		47 μF, 10 V, X7R, 1210, ceramic	Murata	GRM32ER71A476ME15L
			AVX	1210ZC476MAT2A
		100 μF, 6.3 V, X7S, 1210, ceramic	Murata	GRM32EC70J107ME15L
U ₁	1	TLVM13640 36-V, 4-A synchronous buck module	Texas Instruments	TLVM13640RDLR

(1) See the [Third-Party Products Disclaimer](#).

More generally, the TLVM13640 module is designed to operate with a wide range of external components and system parameters. However, the integrated loop compensation is optimized for a certain range of output capacitance.

9.2.1.2 Detailed Design Procedure

9.2.1.2.1 Custom Design With WEBENCH® Tools

[Click here](#) to create a custom design using the TLVM13640 module with WEBENCH® Power Designer.

1. Start by entering the input voltage (V_{IN}), output voltage (V_{OUT}), and output current (I_{OUT}) requirements.
2. Optimize the design for key parameters such as efficiency, footprint, and cost using the optimizer dial.
3. Compare the generated design with other possible solutions from Texas Instruments.

The WEBENCH Power Designer provides a customized schematic along with a list of materials with real-time pricing and component availability.

In most cases, these actions are available:

- Run electrical simulations to see important waveforms and circuit performance.
- Run thermal simulations to understand board thermal performance.
- Export customized schematic and layout into popular CAD formats.
- Print PDF reports for the design, and share the design with colleagues.

Get more information about WEBENCH tools at www.ti.com/WBENCH.

9.2.1.2.2 Output Voltage Setpoint

The output voltage of a TLVM13640 module is externally adjustable using a resistor divider. A recommended value for R_{FBB} of 10 k Ω establishes a divider current of 0.1 mA. Select the value for R_{FBT} from [表 8-1](#) or calculate using [式 9](#):

$$R_{FBT} [k\Omega] = R_{FBB} [k\Omega] \cdot \left(\frac{V_{OUT} [V]}{1V} - 1 \right) = 10k\Omega \cdot \left(\frac{5V}{1V} - 1 \right) = 40k\Omega \quad (9)$$

Choose the closest standard value of 40.2 k Ω for R_{FBT} .

9.2.1.2.3 Switching Frequency Selection

Connect a 13-k Ω resistor from RT to AGND to set a switching frequency of 1 MHz, which is ideal for an output of 5 V as it establishes an inductor peak-to-peak ripple current in the range of 20% to 40% of the 4-A rated output current at a nominal input voltage of 24 V.

9.2.1.2.4 Input Capacitor Selection

The TLVM13640 requires a minimum input capacitance of $2 \times 10\text{-}\mu\text{F}$ ceramic, preferably with X7R dielectric. The voltage rating of input capacitors must be greater than the maximum input voltage. For this design, select two 10- μF , X7R, 50-V, 1210 case size, ceramic capacitors connected from VIN1 and VIN2 to PGND as close as possible to the module. See [图 11-2](#) for recommended layout placement.

9.2.1.2.5 Output Capacitor Selection

From [表 8-1](#), the TLVM13640 requires a minimum of 25 μF of effective output capacitance for proper operation at an output voltage of 5 V. Use high-quality ceramic type capacitors with sufficient voltage and temperature rating. If needed, connect additional output capacitance to reduce ripple voltage or for applications with specific load transient requirements.

For this design example, use two 47- μF , 6.3-V or 10-V, X7R, 1210, ceramic capacitors connected close to the module from the VOUT1 and VOUT2 pins to PGND. The total effective capacitance at 5 V is approximately 52 μF and 38 μF at 25°C and -40°C, respectively.

9.2.1.2.6 Other Connections

Connect VLDOIN to the 5-V output for best efficiency. To increase phase margin when using an output capacitance close to the minimum recommended in [表 8-1](#), use a feedforward capacitor, designated as C_{FF} in [图 9-1](#), across the upper feedback resistor. Based on the feedback resistor values in this application, a capacitor of 22 pF sets a zero-pole pair at 180 kHz and 900 kHz, respectively.

9.2.1.3 Application Curves

Unless otherwise indicated, $V_{IN} = 24\text{ V}$, $V_{OUT} = 5\text{ V}$, $I_{OUT} = 4\text{ A}$ (1.25- Ω resistive load), and $F_{SW} = 1\text{ MHz}$.



图 9-2. Efficiency



图 9-3. Load Regulation

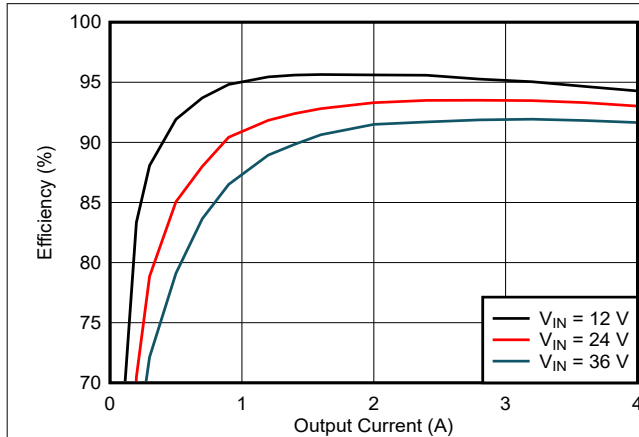

图 9-4. Start-Up, V_{IN} Stepped to 12 V

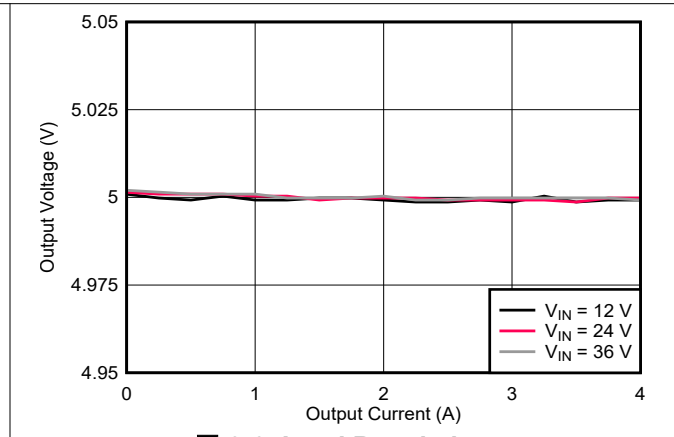

图 9-5. Load Transient, 0 A to 3 A, 1 A/ μ s

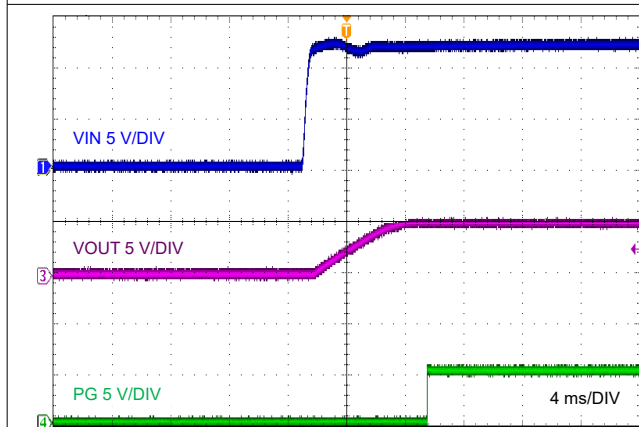

图 9-6. CISPR 32 Class B Conducted Emissions:
 $V_{IN} = 12\text{ V}$

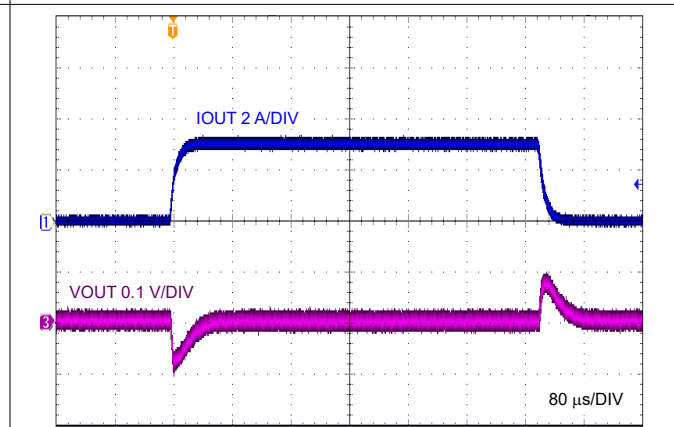

图 9-7. CISPR 32 Class B Conducted Emissions:
 $V_{IN} = 24\text{ V}$

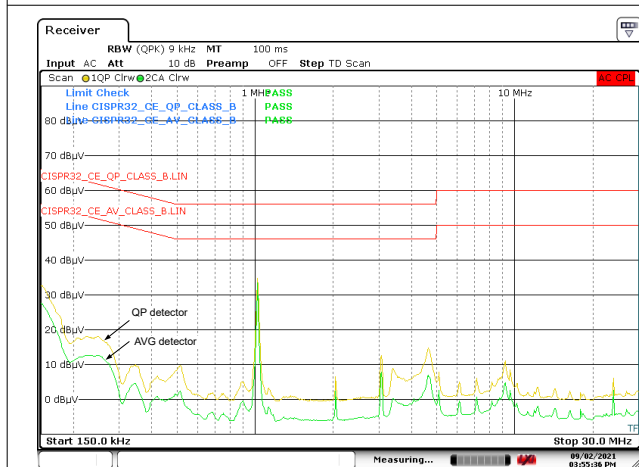

☒ 9-8. CISPR 32 Class B Radiated Emissions: Horizontal Polarization

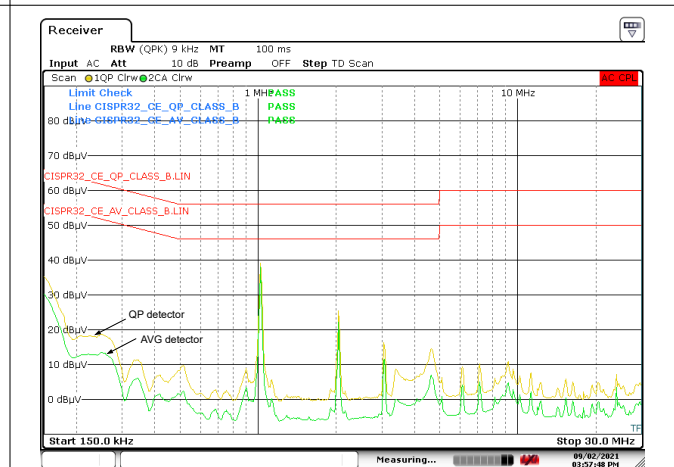

☒ 9-9. CISPR 32 Class B Radiated Emissions: Vertical Polarization

9.2.2 Design 2 – Inverting Buck-Boost Regulator with Negative Output Voltage

Figure 9-10 shows the schematic diagram of an inverting buck-boost (IBB) regulator with an output of -5 V at -3 A and a switching frequency of 1.2 MHz . In this example, the target half-load and full-load efficiencies are 90% and 90.5% , respectively, based on a nominal input voltage of 24 V that ranges from 10 V to 31 V .

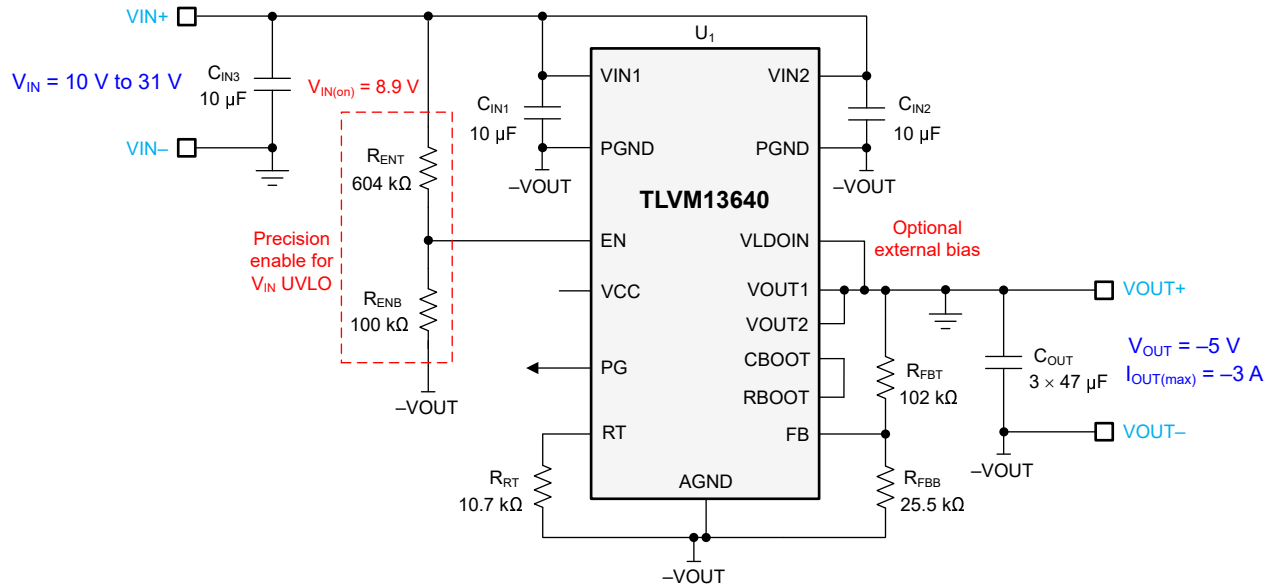

Figure 9-10. Circuit Schematic

9.2.2.1 Design Requirements

Table 9-3 shows the intended input, output, and performance parameters for this application example. With an IBB topology, the module sees a total current of $I_{IN} + |-I_{OUT}|$, which is highest at minimum input voltage.

Table 9-3. Design Parameters

Design Parameter	Value
Input voltage range	10 V to 31 V
Input voltage UVLO turn on	8.9 V
Output voltage	-5 V
Full-load current	-3 A
Switching frequency	1.2 MHz
Output voltage regulation	$\pm 1\%$

Table 9-4 gives the selected buck module power-stage components with availability from multiple vendors. This design uses an all-ceramic output capacitor implementation.

Table 9-4. List of Materials for Application Circuit 2

Ref Des	Qty	Specification	Manufacturer ⁽¹⁾	Part Number
C _{IN1} , C _{IN2} , C _{IN3}	3	10 µF, 50 V, X7R, 1210, ceramic	Kemet	C1210C106K5RACTU
			TDK	CNA6P1X7R1H106K
C _{OUT1} , C _{OUT2}	2	47 µF, 10 V, X7R, 1210, ceramic	Murata	GRM32ER71A476ME15L
		100 µF, 6.3 V, X7S, 1210, ceramic	Murata	GRT32EC70J107ME13L
U ₁	1	TLVM13640 36-V, 4-A synchronous buck module	Texas Instruments	TLVM13640RDLR

(1) See the [Third-Party Products Disclaimer](#).

9.2.2.2 Detailed Design Procedure

9.2.2.2.1 Output Voltage Setpoint

For an output voltage of -5 V , choose upper and lower feedback resistance of $102\text{ k}\Omega$ and $25.5\text{ k}\Omega$, respectively, using [式 1](#).

9.2.2.2.2 IBB Maximum Output Current

The achievable output current with an *IBB topology* using the TLVM13640 is $I_{\text{OUT(max)}} = I_{\text{LDC(max)}} \times (1 - D)$, where $I_{\text{LDC(max)}} = 4\text{ A}$ is the rated current of the module and $D = |V_{\text{OUT}}| / (V_{\text{IN}} + |V_{\text{OUT}}|)$ is the IBB duty cycle. [图 9-11](#) provides the maximum output current capability as a function of input voltage for output voltage setpoints of -3.3 V and -5 V .

9.2.2.2.3 Switching Frequency Selection

Connect a $10.7\text{-k}\Omega$ resistor from RT to AGND to set a switching frequency of 1.2 MHz , which is ideal for an output of -5 V as it establishes an inductor peak-to-peak ripple current of approximately 40% of the 4-A rated module current at the nominal input voltage of 12 V .

9.2.2.2.4 Input Capacitor Selection

Use two $10\text{-}\mu\text{F}$, 50-V , X7R-dielectric ceramic capacitors in 1210 case size connected symmetrically from the VIN1 and VIN2 pins to PGND as close as possible to the module. More specifically, these capacitors appear from the drain of the internal high-side MOSFET to the source of the low-side MOSFET, effectively connecting from the positive input voltage to the negative output voltage terminals.

The sum of the input and output voltages, $V_{\text{IN}} + |-V_{\text{OUT}}|$, is the effective applied voltage across the capacitors. The total effective capacitance at 25°C and input voltages of 12 V and 24 V (corresponding to applied voltages of 17 V and 29 V) is approximately $15\text{ }\mu\text{F}$ and $10\text{ }\mu\text{F}$, respectively. Check the capacitance versus voltage derating curve in the capacitor data sheet.

Use an additional $10\text{-}\mu\text{F}$, 50-V capacitor directly across the input. This capacitor is designated as C_{IN3} and connects across the VIN+ and VIN– terminals as shown in [图 9-10](#).

9.2.2.2.5 Output Capacitor Selection

For this IBB design example, use two $47\text{-}\mu\text{F}$, 10-V , X7R-dielectric ceramic capacitors in 1210 case size connected symmetrically close to the module from the VOUT1 and VOUT2 pins to PGND. The total effective capacitance is approximately $52\text{ }\mu\text{F}$ with DC bias of 5 V .

9.2.2.2.6 Other Considerations

Short RBOOT to CBOOT and connect VLDOIN to the power stage GND terminal (corresponding to VOUT1, VOUT2 of the module) for best efficiency.

The right-half-plane zero of an IBB topology is at its lowest frequency at minimum input voltage and highest load current. Using the TLVM13640 [quickstart calculator](#), select the output capacitance to set that the loop crossover frequency at less than one third of the lowest right-half-plane zero frequency for a given application.

9.2.2.3 Application Curves

Unless otherwise indicated, $V_{IN} = 24\text{ V}$, $V_{OUT} = -5\text{ V}$, $I_{OUT} = -3\text{ A}$ (1.66- Ω resistive load), and $F_{SW} = 1.2\text{ MHz}$.

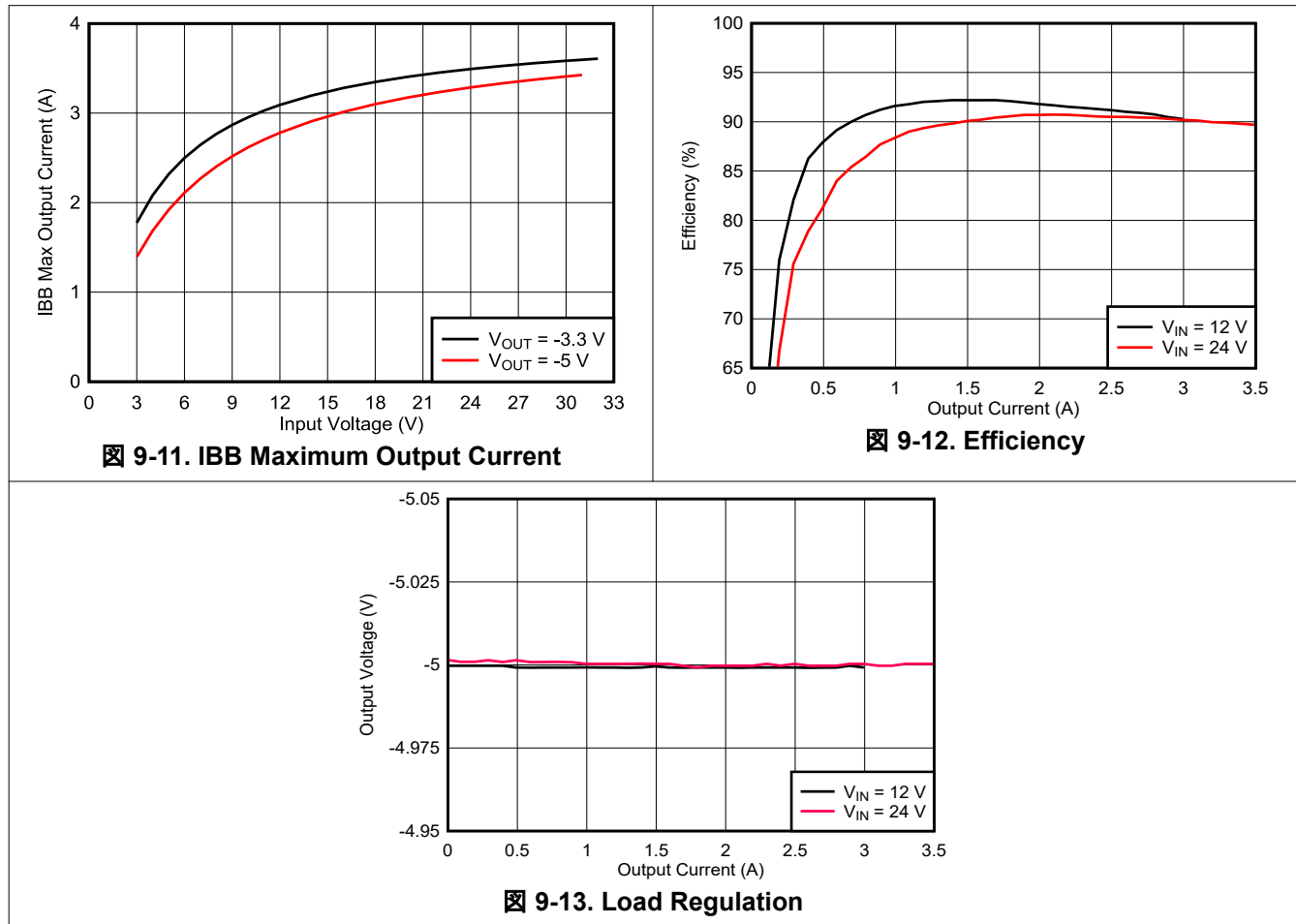

10 Power Supply Recommendations

The TLVM13640 buck module is designed to operate over a wide input voltage range of 3 V to 36 V. The characteristics of the input supply must be compatible with the [Absolute Maximum Ratings](#) and [Recommended Operating Conditions](#) in this data sheet. In addition, the input supply must be capable of delivering the required input current to the loaded regulator circuit. Estimate the average input current with 式 10.

$$I_{IN} = \frac{V_{OUT} \cdot I_{OUT}}{V_{IN} \cdot \eta} \quad (10)$$

where

- η is the efficiency.

If the module is connected to an input supply through long wires or PCB traces with a large impedance, take special care to achieve stable performance. The parasitic inductance and resistance of the input cables can have an adverse affect on module operation. More specifically, the parasitic inductance in combination with the low-ESR ceramic input capacitors form an underdamped resonant circuit, possibly resulting in instability, voltage transients, or both, each time the input supply is cycled ON and OFF. The parasitic resistance causes the input voltage to dip during a load transient. If the module is operating close to the minimum input voltage, this dip can cause false UVLO triggering and a system reset.

The best way to solve such issues is to reduce the distance from the input supply to the module and use an electrolytic input capacitor in parallel with the ceramics. The moderate ESR of the electrolytic capacitor helps damp the input resonant circuit and reduce any overshoot or undershoot at the input. A capacitance in the range of 47 μ F to 100 μ F is usually sufficient to provide input parallel damping and helps hold the input voltage steady during large load transients. A typical ESR of 0.1 Ω to 0.4 Ω provides enough damping for most input circuit configurations.

11 Layout

Proper PCB design and layout is important in high-current, fast-switching module circuits (with high internal voltage and current slew rates) to achieve reliable device operation and design robustness. Furthermore, the EMI performance of the module depends to a large extent on PCB layout.

11.1 Layout Guidelines

The following list summarizes the essential guidelines for PCB layout and component placement to optimize DC/DC module performance, including thermals and EMI signature. [✉ 11-1](#) and [✉ 11-2](#) show a recommended PCB layout for the TLVM13640 with optimized placement and routing of the power-stage and small-signal components.

- *Place input capacitors as close as possible to the VIN pins.* Note the dual and symmetrical arrangement of the input capacitors based on the VIN1 and VIN2 pins located on each side of the module package. The high-frequency currents are split in two and effectively flow in opposing directions such that the related magnetic fields contributions cancel each other, leading to improved EMI performance.
 - Use low-ESR 1206 or 1210 ceramic capacitors with X7R or X7S dielectric. The module has integrated dual 0402 input capacitors for high-frequency bypass.
 - Ground return paths for the input capacitors should consist of localized top-side planes that connect to the PGND pads under the module.
 - Even though the VIN pins are connected internally, use a wide polygon plane on a lower PCB layer to connect these pins together and to the input supply.
- *Place output capacitors as close as possible to the VOUT pins.* A similar dual and symmetrical arrangement of the output capacitors enables magnetic field cancellation and EMI mitigation.
 - Ground return paths for the output capacitors should consist of localized top-side planes that connect to the PGND pads under the module.
 - Even though the VOUT pins are connected internally, use a wide polygon plane on a lower PCB layer to connect these pins together and to the load, thus reducing conduction loss and thermal stress.
- *Keep the FB trace as short as possible by placing the feedback resistors close to the FB pin.* Reduce noise sensitivity of the output voltage feedback path by placing the resistor divider close to the FB pin, rather than close to the load. FB is the input to the voltage-loop error amplifier and represents a high-impedance node sensitive to noise. Route a trace from the upper feedback resistor to the required point of output voltage regulation.
- *Use a solid ground plane on the PCB layer directly below the top layer with the module.* This plane acts as a noise shield by minimizing the magnetic fields associated with the currents in the switching loops. Connect AGND pins 6 and 11 directly to PGND pin 19 under the module.
- *Provide enough PCB area for proper heatsinking.* Use sufficient copper area to achieve a low thermal impedance commensurate with the maximum load current and ambient temperature conditions. Provide adequate heatsinking for the TLVM13640 to keep the junction temperature below 150°C. For operation at full rated load, the top-side ground plane is an important heat-dissipating area. Use an array of heat-sinking vias to connect the exposed pads (PGND) of the package to the PCB ground plane. If the PCB has multiple copper layers, connect these thermal vias to inner-layer ground planes. Make the top and bottom PCB layers preferably with two-ounce copper thickness (and no less than one ounce).

11.1.1 Thermal Design and Layout

For a DC/DC module to be useful over a particular temperature range, the package must allow for the efficient removal of the heat produced while keeping the junction temperature within rated limits. The TLVM13640 module is available in a small 5.5-mm × 5-mm 20-pin QFN (RDL) package to cover a range of application requirements. The [Thermal Information](#) table summarizes the thermal metrics of this package with related detail provided by the [Semiconductor and IC Package Thermal Metrics Application Report](#).

The 20-pin QFN package offers a means of removing heat through the exposed thermal pads at the base of the package. This allows a significant improvement in heatsinking, and it becomes imperative that the PCB is designed with thermal lands, thermal vias, and one or more ground planes to complete the heat removal subsystem. The exposed pads of the TLVM13640 are soldered to the ground-connected copper lands on the PCB directly underneath the device package, reducing the thermal resistance to a very low value.

Preferably, use a four-layer board with 2-oz copper thickness for all layers to provide low impedance, proper shielding and lower thermal resistance. Numerous vias with a 0.3-mm diameter connected from the thermal lands to the internal and solder-side ground planes are vital to promote heat transfer. In a multi-layer PCB stack-up, a solid ground plane is typically placed on the PCB layer below the power-stage components. Not only does this provide a plane for the power-stage currents to flow, but it also represents a thermally conductive path away from the heat-generating device.

11.2 Layout Example

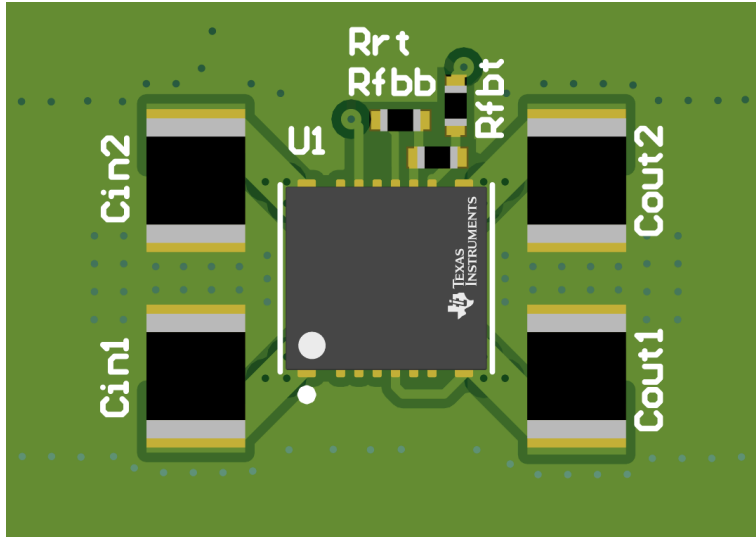

11-1. Typical Layout

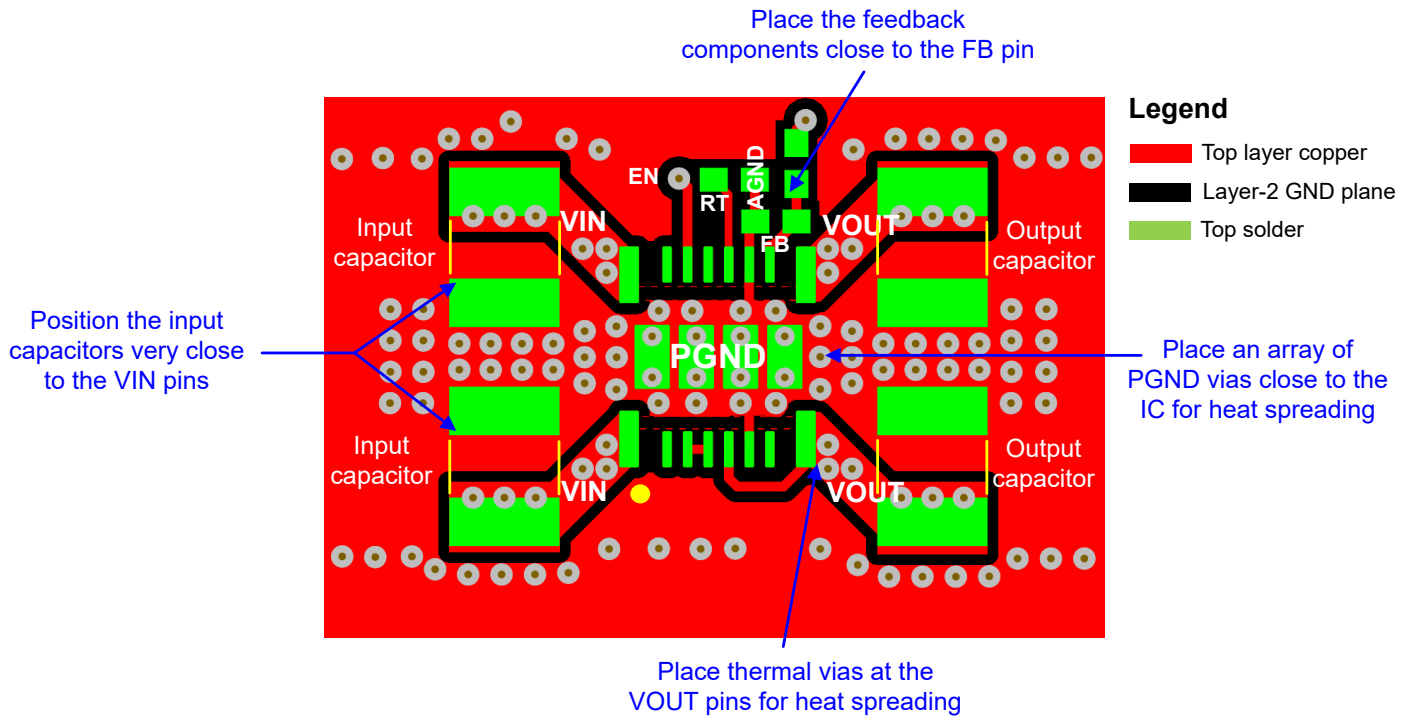

11-2. Typical Top Layer Design

11.2.1 Package Specifications

表 11-1. Package Specifications Table

TLVM13640		VALUE	UNIT
Weight		748	mg
Flammability	Meets UL 94 V-0		
MTBF calculated reliability	Per Bellcore TR-332, 50% stress, $T_A = 40^\circ\text{C}$, ground benign	2580	MHrs

12 Device and Documentation Support

12.1 Device Support

12.1.1 Third-Party Products Disclaimer

TI'S PUBLICATION OF INFORMATION REGARDING THIRD-PARTY PRODUCTS OR SERVICES DOES NOT CONSTITUTE AN ENDORSEMENT REGARDING THE SUITABILITY OF SUCH PRODUCTS OR SERVICES OR A WARRANTY, REPRESENTATION OR ENDORSEMENT OF SUCH PRODUCTS OR SERVICES, EITHER ALONE OR IN COMBINATION WITH ANY TI PRODUCT OR SERVICE.

12.1.2 Development Support

With an input operating voltage from 3 V to 36 V and rated output current from 2 A to 6 A, the TLVM13620/30/40/60 family of synchronous buck power modules specified in [表 12-1](#) provides flexibility, scalability and optimized solution size for a range of applications. These modules enable DC/DC solutions with high density, low EMI and increased flexibility. Available EMI mitigation features include RBOOT-configured switch-node slew rate control, fixed switching frequency, and integrated input bypass capacitors. All modules are rated for an ambient temperature up to 105°C.

表 12-1. Synchronous Buck DC/DC Power Module Family

DC/DC Module	Rated I _{OUT}	Package	Dimensions	Features	EMI Mitigation
TLVM13620	2 A	B0QFN (30)	6.0 × 4.0 × 1.8 mm	RT adjustable F _{SW} , precision enable	Integrated input, VCC, and BOOT capacitors
TLVM13630	3 A				
TLVM13640	4 A	B3QFN (20)	5.5 × 5.0 × 4.0 mm		
TLVM13660	6 A				

For development support see the following:

- [TLVM13640 Quickstart Calculator](#)
- [TLVM13640 Simulation Models](#)
- [TLVM13660 EVM user's guide](#)
- [TLVM13660 EVM Layout Files \(Altium\)](#)
- For TI's reference design library, visit the [TI Reference Design library](#).
- For TI's WEBENCH Design Environment, visit the [WEBENCH® Design Center](#).
- To design a low-EMI power supply, review TI's comprehensive [EMI Training Series](#).
- To design an inverting buck-boost (IBB) regulator, visit [DC/DC inverting buck-boost modules](#).
- TI Reference Designs:
 - [Multiple Output Power Solution For Kintex 7 Application](#)
 - [Arria V Power Reference Design](#)
 - [Altera Cyclone V SoC Power Supply Reference Design](#)
 - [Space-optimized DC/DC Inverting Power Module Reference Design With Minimal BOM Count](#)
 - [3- To 11.5-V_{IN}, -5-V_{OUT}, 1.5-A Inverting Power Module Reference Design For Small, Low-noise Systems](#)
- Technical Articles:
 - [Powering Medical Imaging Applications With DC/DC Buck Converters](#)
 - [How To Create A Programmable Output Inverting Buck-boost Regulator](#)
- To view a related device of this product, see the [LM61460 36-V, 6-A synchronous buck converter](#).

12.1.2.1 Custom Design With WEBENCH® Tools

[Click here](#) to create a custom design using the TLVM13640 module with WEBENCH® Power Designer.

1. Start by entering the input voltage (V_{IN}), output voltage (V_{OUT}), and output current (I_{OUT}) requirements.
2. Optimize the design for key parameters such as efficiency, footprint, and cost using the optimizer dial.
3. Compare the generated design with other possible solutions from Texas Instruments.

The WEBENCH Power Designer provides a customized schematic along with a list of materials with real-time pricing and component availability.

In most cases, these actions are available:

- Run electrical simulations to see important waveforms and circuit performance.
- Run thermal simulations to understand board thermal performance.
- Export customized schematic and layout into popular CAD formats.
- Print PDF reports for the design, and share the design with colleagues.

Get more information about WEBENCH tools at www.ti.com/WEBENCH.

12.2 Documentation Support

12.2.1 Related Documentation

For related documentation, see the following:

- Texas Instruments, [Innovative DC/DC Power Modules](#) selection guide
- Texas Instruments, [Enabling Small, Cool and Quiet Power Modules with Enhanced HotRod™ QFN Package Technology](#) white paper
- Texas Instruments, [Benefits and Trade-offs of Various Power-Module Package Options](#) white paper
- Texas Instruments, [Simplify Low EMI Design with Power Modules](#) white paper
- Texas Instruments, [Power Modules for Lab Instrumentation](#) white paper
- Texas Instruments, [An Engineer's Guide To EMI In DC/DC Regulators](#) e-book
- Texas Instruments, [Soldering Considerations for Power Modules](#) application report
- Texas Instruments, [Practical Thermal Design With DC/DC Power Modules](#) application report
- Texas Instruments, [Using New Thermal Metrics](#) application report
- Texas Instruments, [AN-2020 Thermal Design By Insight, Not Hindsight](#) application report
- Texas Instruments, [Using the TPSM53602/3/4 for Negative Output Inverting Buck-Boost Applications](#) application report

12.3 Receiving Notification of Documentation Updates

To receive notification of documentation updates, navigate to the device product folder on ti.com. Click on *Subscribe to updates* to register and receive a weekly digest of any product information that has changed. For change details, review the revision history included in any revised document.

12.4 サポート・リソース

TI E2E™ サポート・フォーラムは、エンジニアが検証済みの回答と設計に関するヒントをエキスパートから迅速かつ直接得ることができる場所です。既存の回答を検索したり、独自の質問をしたりすることで、設計に必要な支援を迅速に得ることができます。

リンクされているコンテンツは、該当する貢献者により、現状のまま提供されるものです。これらは TI の仕様を構成するものではなく、必ずしも TI の見解を反映したものではありません。TI の [使用条件](#) を参照してください。

12.5 Trademarks

HotRod™ and TI E2E™ are trademarks of Texas Instruments.

WEBENCH® is a registered trademark of Texas Instruments.

すべての商標は、それぞれの所有者に帰属します。

12.6 Electrostatic Discharge Caution



This integrated circuit can be damaged by ESD. Texas Instruments recommends that all integrated circuits be handled with appropriate precautions. Failure to observe proper handling and installation procedures can cause damage.

ESD damage can range from subtle performance degradation to complete device failure. Precision integrated circuits may be more susceptible to damage because very small parametric changes could cause the device not to meet its published specifications.

12.7 Glossary

[TI Glossary](#)

This glossary lists and explains terms, acronyms, and definitions.

13 Mechanical, Packaging, and Orderable Information

The following pages include mechanical packaging and orderable information. This information is the most current data available for the designated devices. This data is subject to change without notice and revision of this document. For browser-based versions of this datasheet, refer to the left-hand navigation.

PACKAGING INFORMATION

Orderable Device	Status (1)	Package Type	Package Drawing	Pins	Package Qty	Eco Plan (2)	Lead finish/ Ball material (6)	MSL Peak Temp (3)	Op Temp (°C)	Device Marking (4/5)	Samples
TLVM13640RDLR	ACTIVE	B3QFN	RDL	20	1000	RoHS Exempt & Green	NIPDAU	Level-3-250C-168 HR	-40 to 125	TLVM13640 B1	Samples

(1) The marketing status values are defined as follows:

ACTIVE: Product device recommended for new designs.

LIFEBUY: TI has announced that the device will be discontinued, and a lifetime-buy period is in effect.

NRND: Not recommended for new designs. Device is in production to support existing customers, but TI does not recommend using this part in a new design.

PREVIEW: Device has been announced but is not in production. Samples may or may not be available.

OBSOLETE: TI has discontinued the production of the device.

(2) **RoHS:** TI defines "RoHS" to mean semiconductor products that are compliant with the current EU RoHS requirements for all 10 RoHS substances, including the requirement that RoHS substance do not exceed 0.1% by weight in homogeneous materials. Where designed to be soldered at high temperatures, "RoHS" products are suitable for use in specified lead-free processes. TI may reference these types of products as "Pb-Free".

RoHS Exempt: TI defines "RoHS Exempt" to mean products that contain lead but are compliant with EU RoHS pursuant to a specific EU RoHS exemption.

Green: TI defines "Green" to mean the content of Chlorine (Cl) and Bromine (Br) based flame retardants meet JS709B low halogen requirements of <=100ppm threshold. Antimony trioxide based flame retardants must also meet the <=1000ppm threshold requirement.

(3) MSL, Peak Temp. - The Moisture Sensitivity Level rating according to the JEDEC industry standard classifications, and peak solder temperature.

(4) There may be additional marking, which relates to the logo, the lot trace code information, or the environmental category on the device.

(5) Multiple Device Markings will be inside parentheses. Only one Device Marking contained in parentheses and separated by a "~" will appear on a device. If a line is indented then it is a continuation of the previous line and the two combined represent the entire Device Marking for that device.

(6) Lead finish/Ball material - Orderable Devices may have multiple material finish options. Finish options are separated by a vertical ruled line. Lead finish/Ball material values may wrap to two lines if the finish value exceeds the maximum column width.

Important Information and Disclaimer:The information provided on this page represents TI's knowledge and belief as of the date that it is provided. TI bases its knowledge and belief on information provided by third parties, and makes no representation or warranty as to the accuracy of such information. Efforts are underway to better integrate information from third parties. TI has taken and continues to take reasonable steps to provide representative and accurate information but may not have conducted destructive testing or chemical analysis on incoming materials and chemicals. TI and TI suppliers consider certain information to be proprietary, and thus CAS numbers and other limited information may not be available for release.

In no event shall TI's liability arising out of such information exceed the total purchase price of the TI part(s) at issue in this document sold by TI to Customer on an annual basis.

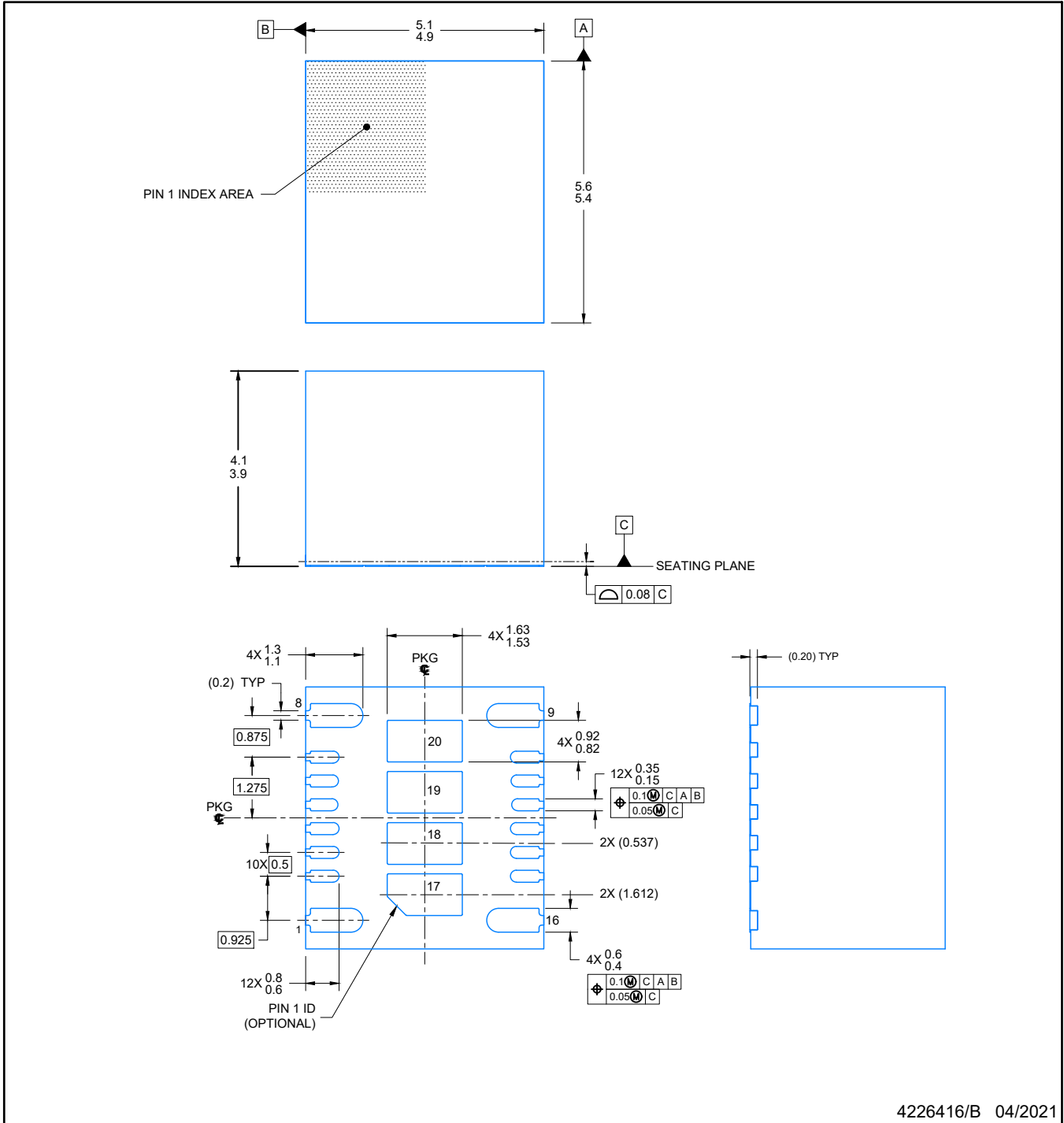

4226416/B 04/2021

NOTES:

1. All linear dimensions are in millimeters. Any dimensions in parenthesis are for reference only. Dimensioning and tolerancing per ASME Y14.5M.
2. This drawing is subject to change without notice.
3. The package thermal pad must be soldered to the printed circuit board for optimal thermal and mechanical performance.

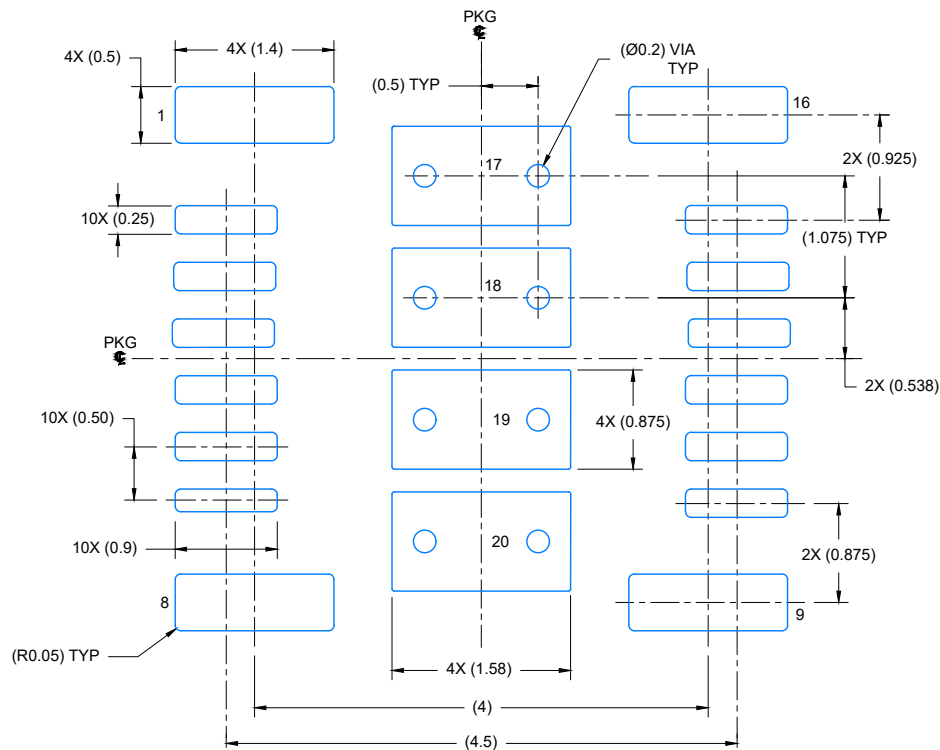

LAND PATTERN EXAMPLE
EXPOSED METAL SHOWN
SCALE: 15X

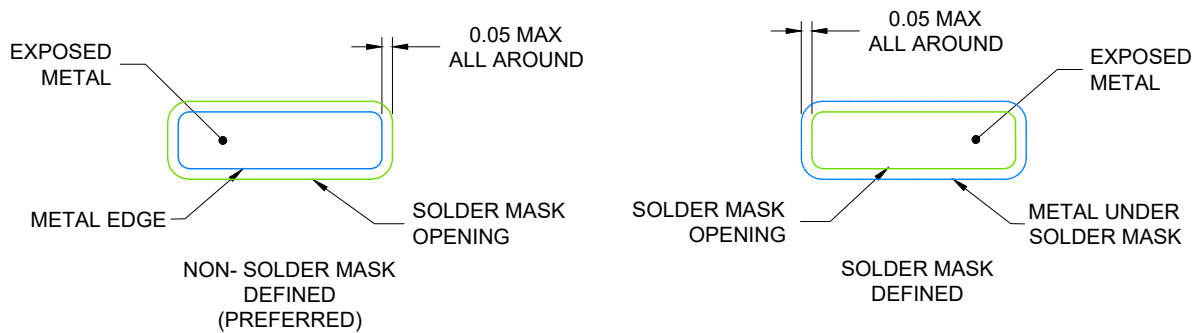

SOLDER MASK DETAILS

4226416/B 04/2021

NOTES: (continued)

4. This package is designed to be soldered to a thermal pad on the board. For more information, see Texas Instruments literature number SLUA271 (www.ti.com/lit/sluea271).
5. Vias are optional depending on application, refer to device data sheet. If any vias are implemented, refer to their locations shown on this view. It is recommended that vias under paste be filled, plugged or tented.

EXAMPLE STENCIL DESIGN

RDL0020A

B3QFN - 4.1 mm max height

PLASTIC QUAD FLAT PACK- NO LEAD

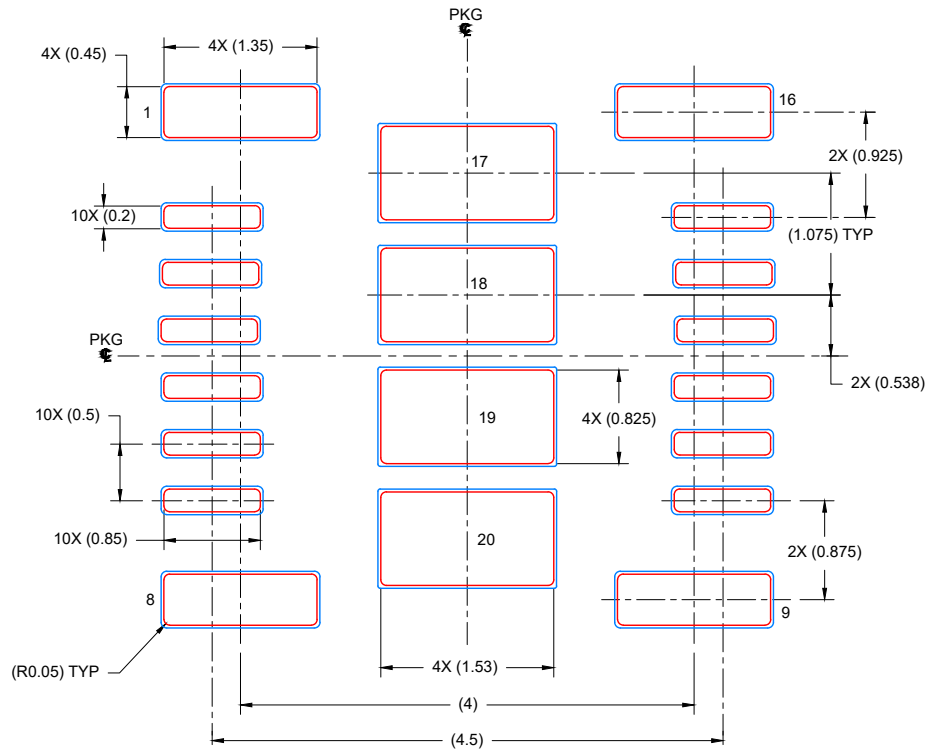

SOLDER PASTE EXAMPLE
BASED ON 0.125 mm THICK STENCIL

EXPOSED PAD 17,18, 19 & 20 :
91% PRINTED SOLDER COVERAGE BY AREA
SCALE: 15X

4226416/B 04/2021

NOTES: (continued)

6. Laser cutting apertures with trapezoidal walls and rounded corners may offer better paste release. IPC-7525 may have alternate design recommendations.

重要なお知らせと免責事項

TI は、技術データと信頼性データ(データシートを含みます)、設計リソース(リファレンス・デザインを含みます)、アプリケーションや設計に関する各種アドバイス、Web ツール、安全性情報、その他のリソースを、欠陥が存在する可能性のある「現状のまま」提供しており、商品性および特定目的に対する適合性の黙示保証、第三者の知的財産権の非侵害保証を含むいかなる保証も、明示的または黙示的にかかわらず拒否します。

これらのリソースは、TI 製品を使用する設計の経験を積んだ開発者への提供を意図したものです。(1) お客様のアプリケーションに適した TI 製品の選定、(2) お客様のアプリケーションの設計、検証、試験、(3) お客様のアプリケーションに該当する各種規格や、その他のあらゆる安全性、セキュリティ、規制、または他の要件への確実な適合に関する責任を、お客様のみが単独で負うものとし、

上記の各種リソースは、予告なく変更される可能性があります。これらのリソースは、リソースで説明されている TI 製品を使用するアプリケーションの開発の目的でのみ、TI はその使用をお客様に許諾します。これらのリソースに関して、他の目的で複製することや掲載することは禁止されています。TI や第三者の知的財産権のライセンスが付与されている訳ではありません。お客様は、これらのリソースを自身で使用した結果発生するあらゆる申し立て、損害、費用、損失、責任について、TI およびその代理人を完全に補償するものとし、TI は一切の責任を拒否します。

TI の製品は、[TI の販売条件](#)、または ti.com やかかる TI 製品の関連資料などのいずれかを通じて提供する適用可能な条項の下で提供されています。TI がこれらのリソースを提供することは、適用される TI の保証または他の保証の放棄の拡大や変更を意味するものではありません。

お客様がいかなる追加条項または代替条項を提案した場合でも、TI はそれらに異議を唱え、拒否します。

郵送先住所 : Texas Instruments, Post Office Box 655303, Dallas, Texas 75265

Copyright © 2022, Texas Instruments Incorporated