

TMAG5233 コスト最適化設計向けの同一面内ホール効果スイッチ

1 特長

- 電源電圧範囲:
 - 40°C~85°C: 1.65V~5.5V
- 同一面内の感度軸
- 磁気ポール検出:
 - オムニポーラ (±)
- 出力タイプ:
 - プッシュプル (CMOS)
- アクティブ出力状態 ($B > B_{OP}$ のとき): Low (V_{OL})
- 磁気動作点 (B_{OP}): ±3mT
- 磁気解放点 (B_{RP}): ±2.2mT
- デューティサイクル動作により I_{CC} を最小化
 - 5Hz: 0.55μA (プレビュー)
 - 40Hz: 2.7μA
- 業界標準のパッケージとピン配置
 - 3ピン SOT-23 (V_{CC} , GND, OUT)

2 アプリケーション

- ドアや窓のセンサ
- 家電製品のドア開閉
- 電気メーターの改ざん検出
- 電子スマートロック
- 煙探知器プッシュボタン
- フードプロセッサのアクセサリ検出
- ノート PC

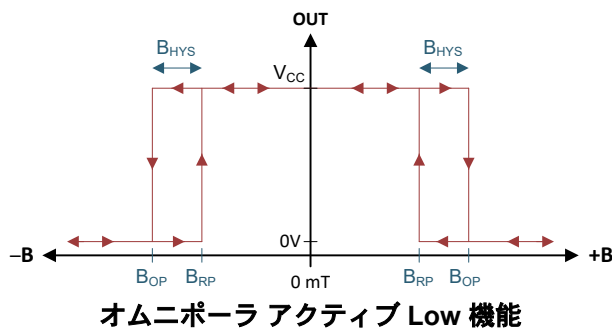

3 概要

TMAG5233 は、コスト低減が重要なアプリケーションで使用される TMR、AMR、リードスイッチを置き換えるように設計された、同一面内ホール効果スイッチです。

TMAG5233 はオムニポーラ磁気応答を備えており、デバイスは N 極と S 極の両方に反応できます。センサの感度軸に印加されている磁束密度が動作点スレッシュホールド (B_{OP}) を超えると、デバイスは Low 電圧を出力します。磁束密度が解放点スレッシュホールド (B_{RP}) を下回るまで、出力は Low 電圧のまま維持され、その後は High 電圧が出力されます。

消費電力を最小限に抑えるため、TMAG5233 は内部的にデューティサイクルを実行します。このデバイスにはプッシュプル (CMOS) 出力があるため、外付けプルアップ抵抗が不要です。また、業界標準の SOT-23 パッケージで供給されます。

パッケージ情報

部品番号	パッケージ ⁽¹⁾	パッケージサイズ ⁽²⁾
TMAG5233	DBV (SOT-23, 3)	2.9mm × 2.8mm

- 供給されているすべてのパッケージについては、[セクション 11](#) を参照してください。
- パッケージサイズ (長さ × 幅) は公称値であり、該当する場合はピンも含まれます。

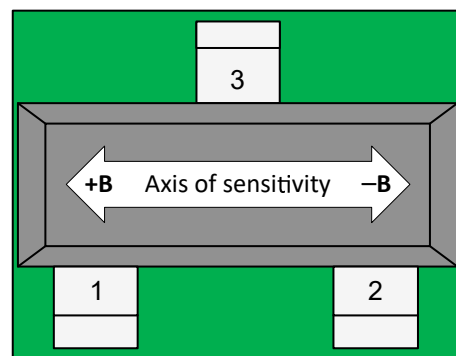

Top View

同一面内の感度軸



Table of Contents

1 特長.....	1	7.3 Feature Description.....	6
2 アプリケーション.....	1	7.4 Device Functional Modes.....	8
3 概要.....	1	8 Application and Implementation.....	9
4 Device Comparison.....	2	8.1 Application Information.....	9
5 Pin Configuration and Functions.....	2	8.2 Typical Application.....	9
6 Specifications.....	3	8.3 Power Supply Recommendations.....	11
6.1 Absolute Maximum Ratings.....	3	8.4 Layout.....	11
6.2 ESD Ratings.....	3	9 Device and Documentation Support.....	12
6.3 Recommended Operating Conditions.....	3	9.1 Device Nomenclature.....	12
6.4 Thermal Information.....	3	9.2 ドキュメントの更新通知を受け取る方法.....	12
6.5 Electrical Characteristics.....	4	9.3 サポート・リソース.....	12
6.6 Magnetic Characteristics.....	4	9.4 静電気放電に関する注意事項.....	12
6.7 Typical Characteristics.....	5	9.5 用語集.....	12
7 Detailed Description.....	6	10 Revision History.....	13
7.1 Overview.....	6	11 Mechanical, Packaging, and Orderable Information.....	13
7.2 Functional Block Diagram.....	6		

4 Device Comparison

表 4-1. Device Comparison

VERSION	TYPICAL THRESHOLD	TYPICAL HYSTERESIS	MAGNETIC RESPONSE	OUTPUT TYPE	SAMPLING RATE	PACKAGES AVAILABLE
TMAG5233D1B ⁽¹⁾	3mT	0.8mT	Omnipolar, active low	Push-pull	5Hz	SOT-23 (DBV)
TMAG5233D1E	3mT	0.8mT	Omnipolar, active low	Push-pull	40Hz	SOT-23 (DBV)

(1) Preview only. For additional magnetic threshold, output type, and frequency versions please contact your local Texas Instruments representative.

5 Pin Configuration and Functions



図 5-1. DBV Package 3-Pin SOT-23 Top View

表 5-1. Pin Functions

PIN		TYPE	DESCRIPTION
NAME	SOT-23		
VCC	1	P	Supply voltage
OUT	2	O	Omnipolar output, responds to both positive and negative magnetic flux density through the package.
GND	3	G	Ground

6 Specifications

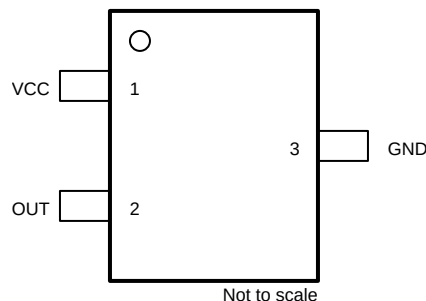
6.1 Absolute Maximum Ratings

over operating free-air temperature range (unless otherwise noted)⁽¹⁾

		MIN	MAX	UNIT
Power supply voltage	V_{CC} $T_A = -40^{\circ}\text{C to } 85^{\circ}\text{C}$	-0.3	6	V
Output pin voltage	OUT	GND - 0.3	$V_{CC} + 0.3$	V
Output pin current	OUT	-5.5	5.5	mA
Magnetic flux density, B_{MAX}		Unlimited		T
Junction temperature, T_J		-65	150	$^{\circ}\text{C}$
Storage temperature, T_{stg}		-65	150	$^{\circ}\text{C}$

- (1) Operation outside the Absolute Maximum Ratings may cause permanent device damage. Absolute Maximum Ratings do not imply functional operation of the device at these or any other conditions beyond those listed under Recommended Operating Conditions. If used outside the Recommended Operating Conditions but within the Absolute Maximum Ratings, the device may not be fully functional, and this may affect device reliability, functionality, performance, and shorten the device lifetime.

6.2 ESD Ratings

			VALUE	UNIT
$V_{(ESD)}$	Electrostatic discharge	Human body model (HBM), per ANSI/ESDA/JEDEC JS-001, all pins ⁽¹⁾	± 2000	V
		Charged device model (CDM), ANSI/ESDA/JEDEC JS-002 ⁽²⁾	± 500	

- (1) JEDEC document JEP155 states that 500V HBM allows safe manufacturing with a standard ESD control process.
 (2) JEDEC document JEP157 states that 250V CDM allows safe manufacturing with a standard ESD control process.

6.3 Recommended Operating Conditions

over operating free-air temperature range (unless otherwise noted)

		MIN	MAX	UNIT
V_{CC}	Power supply voltage	1.65	5.5	V
T_A	Ambient temperature	-40	85	$^{\circ}\text{C}$
V_O	Output voltage	GND	V_{CC}	V
I_O	Output current	-5	5	mA

6.4 Thermal Information

THERMAL METRIC ⁽¹⁾		TMAG5233	UNIT
		SOT-23 (DBV)	
		3 PINS	
$R_{\theta JA}$	Junction-to-ambient thermal resistance	264.5	$^{\circ}\text{C/W}$
$R_{\theta JC(top)}$	Junction-to-case (top) thermal resistance	125.4	$^{\circ}\text{C/W}$
$R_{\theta JB}$	Junction-to-board thermal resistance	108.9	$^{\circ}\text{C/W}$
Ψ_{JT}	Junction-to-top characterization parameter	66.7	$^{\circ}\text{C/W}$
Ψ_{JB}	Junction-to-board characterization parameter	108	$^{\circ}\text{C/W}$

- (1) For more information about traditional and new thermal metrics, see the [Semiconductor and IC Package Thermal Metrics](#) application note.

6.5 Electrical Characteristics

Over free-air temperature range and supply (unless otherwise noted); Typical specifications are at $T_A = 25^\circ\text{C}$ (unless otherwise noted)

PARAMETER		TEST CONDITIONS	MIN	TYP	MAX	UNIT
PUSH-PULL (CMOS) OUTPUT						
V_{OH}	High-level output voltage	$I_O = -0.5\text{mA}$	$V_{CC} - 0.4$		V_{CC}	V
V_{OL}	Low-level output voltage	$I_O = 0.5\text{mA}$	0		0.4	V
ALL VERSIONS						
$I_{CC(ACTIVE)}$	Supply current during measurement			2.6		mA
$I_{CC(SLEEP)}$	Sleep current			315		nA
t_{ON}	Power-on time	$V_{CC} = 5.5\text{V}$		32		μs
t_{ACTIVE}	Active time period			26		μs
TMAG5233xxB 5Hz (PRODUCT PREVIEW)						
f_S	Frequency of magnetic sampling		2	5	8	Hz
t_S	Period of magnetic sampling		125	200	500	ms
$I_{CC(AVG)}$	Average current consumption	$T_A = 25^\circ\text{C}$		0.55	0.89	μA
		$T_A = -40^\circ\text{C to } 85^\circ\text{C}$			1.29	
TMAG5233xxE 40Hz						
f_S	Frequency of magnetic sampling		28	40	53	Hz
t_S	Period of magnetic sampling		18	25	36	ms
$I_{CC(AVG)}$	Average current consumption	$T_A = 25^\circ\text{C}$		2.7	3.7	μA
		$T_A = -40^\circ\text{C to } 85^\circ\text{C}$			4	

6.6 Magnetic Characteristics

Over free-air temperature range and supply (unless otherwise noted); Typical specifications are at $T_A = 25^\circ\text{C}$ (unless otherwise noted)

PARAMETER		TEST CONDITIONS	MIN	TYP	MAX	UNIT
TMAG5233Dxx 3 mT						
B_{OP}	Magnetic operate point	$T_A = 25^\circ\text{C}$	± 1.6	± 3	± 4.3	mT
		$T_A = -40^\circ\text{C to } 85^\circ\text{C}$	± 1.2	± 3	± 4.5	
B_{RP}	Magnetic release point	$T_A = 25^\circ\text{C}$	± 0.6	± 2.2	± 3.5	mT
		$T_A = -40^\circ\text{C to } 85^\circ\text{C}$	± 0.6	± 2.2	± 3.5	
B_{HYS}	Magnetic hysteresis: $ B_{OP} - B_{RP} $	$T_A = -40^\circ\text{C to } 85^\circ\text{C}$		0.8		mT

6.7 Typical Characteristics

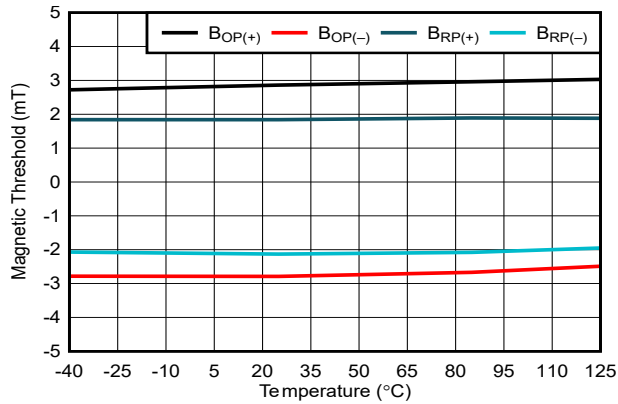

6-1. Magnetic Thresholds vs Temperature

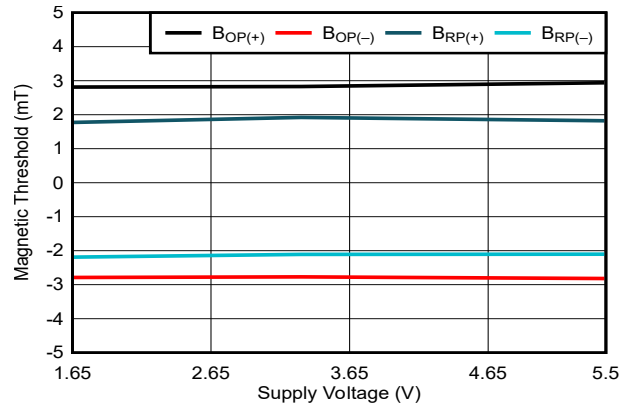

6-2. Magnetic Thresholds vs Supply Voltage

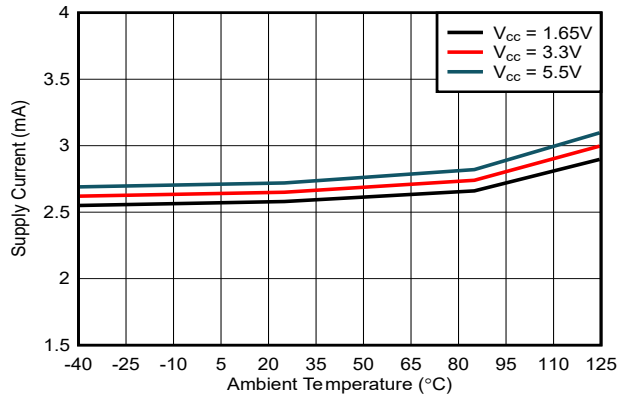

6-3. 40Hz: Average I_{CC} vs Temperature

7 Detailed Description

7.1 Overview

The TMAG5233 is an alternative to expensive TMR, AMR and Reed switches, enabling magnetic position sensing for cost-optimized designs. The TMAG5233 is a Hall-effect sensor with a single digital output that indicates when the magnetic flux density thresholds (B_{OP} and B_{RP}) have been crossed. The output features a push-pull (CMOS) architecture that allows the device to drive the output high or pull the output low, eliminating the need for an external pullup resistor.

As an omnipolar switch, the TMAG5233 OUT pin responds to both positive and negative magnetic flux density along the axis of sensitivity on the sensor. As seen in , a south pole near pin 1 of the DBV package induces a positive magnetic flux density, while a north pole near pin 1 of the DBV package induces a negative magnetic flux density. The output type is active low, meaning the device pulls the output pin low when the magnetic flux density exceeds B_{OP} and drives the output high when the magnetic flux density falls below B_{RP} .

The TMAG5233 integrates a Hall-effect element, analog signal conditioning, and a low-frequency oscillator. The TMAG5233 operates as a duty-cycled device, periodically measuring the magnetic flux density, updating the output, and entering a low-power sleep state between measurements to conserve power.

7.2 Functional Block Diagram

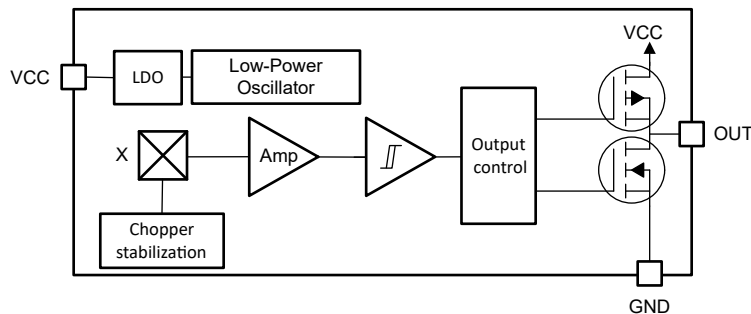

 7-1. SOT-23 Block Diagram

7.3 Feature Description

7.3.1 SOT-23 Magnetic Flux Density Direction

The TMAG5233 SOT-23 detects the magnetic flux density which is horizontal to the package marking surface.

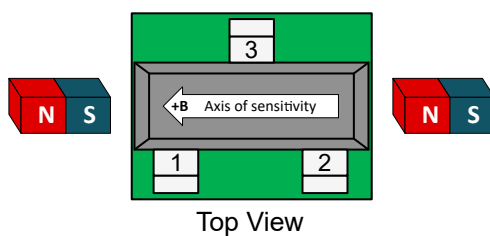

 7-2. Positive Magnetic Flux Density

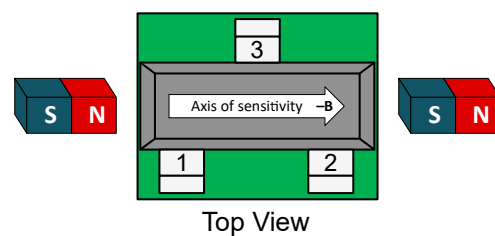

 7-3. Negative Magnetic Flux Density

Magnetic flux density traveling from the pin 2 side of the package to the pin 1 side of the package is considered positive, while magnetic flux density traveling from the pin 1 side of the package to the pin 2 side of the package is considered negative.

A magnet creates a three-dimensional magnetic field that permeates the surrounding space, with field strength and direction varying at different points. This variation allows for multiple ways to induce a positive (or negative) magnetic flux density, as illustrated in 7-4 and 7-5.

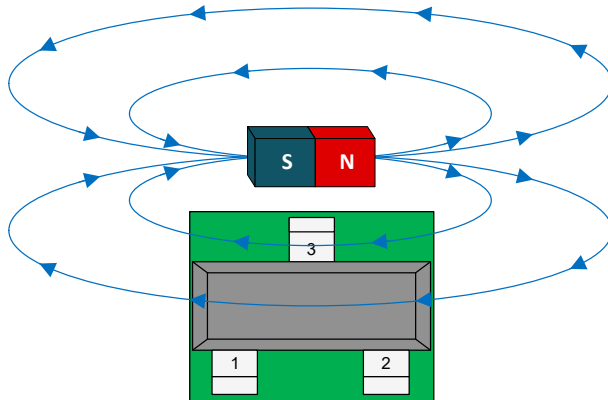

7-4. Positive Magnetic Flux Density: Magnet Offset

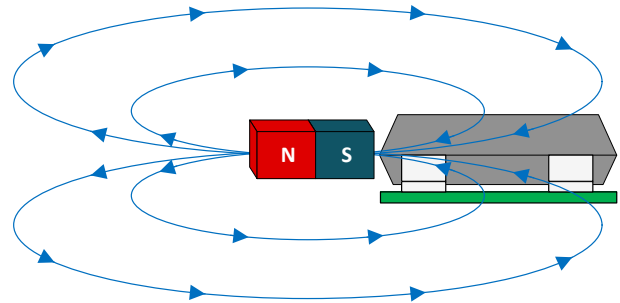

7-5. Positive Magnetic Flux Density: Magnet In-Line

7.3.2 Output Type

The TMAG5233 is an omnipolar switch, meaning the OUT pin responds to both positive and negative magnetic flux densities. As an active low, push-pull (CMOS) output device, the TMAG5233 pulls the output low when the magnetic flux density exceeds the magnetic operate point (B_{OP}). The output remains low until the magnetic flux density falls below the magnetic release point (B_{RP}). 7-6 shows this omnipolar, active low output behavior. 7-7 shows a simplified diagram of the push-pull CMOS architecture that allows the device to drive the output high or pull the output low, eliminating the need for an external pullup resistor.

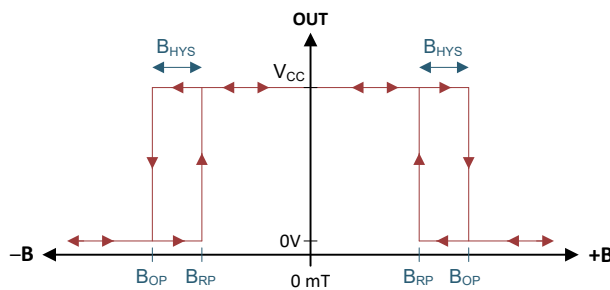

7-6. Omnipolar Output Response

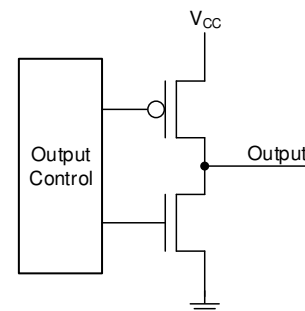

7-7. Push-Pull (CMOS) Output (Simplified)

7.3.3 Timing

7-8 displays the start-up behavior of the TMAG5233 and some examples of the output pin voltage based on different magnetic flux density scenarios. When the minimum value for V_{CC} is reached, the TMAG5233 takes time (t_{ON}) to power up, measure the first magnetic sample, and set the output value. When the output value is set, the output is latched and the device enters a low power sleep state. After each t_s time has passed, the device measures a new sample and updates the output if necessary. If the magnetic field does not change between periods, the output also does not change.

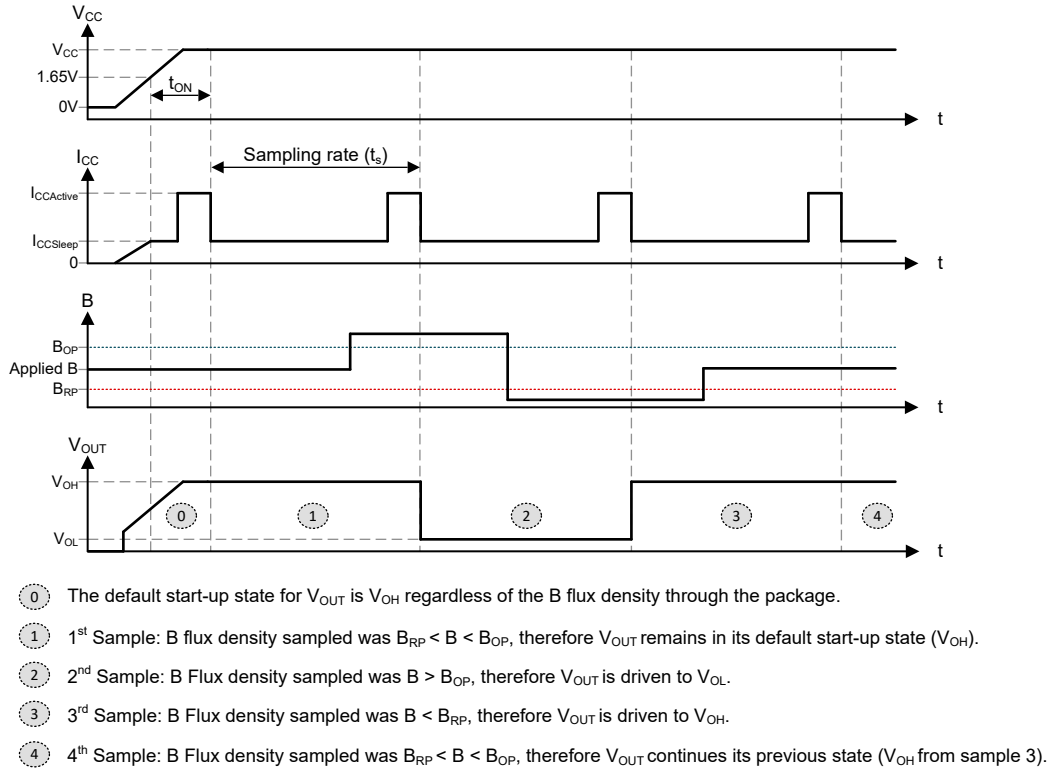

7-8. Timing and Output Diagram

7.3.4 Hall Element Location

The sensing element inside the device is in the center of the SOT-23 package when viewed from the top. 7-9 shows the tolerances and side-view dimensions.

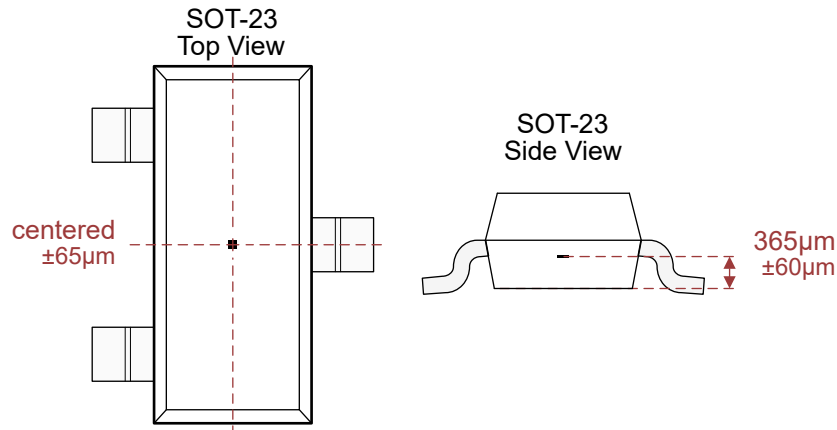

7-9. Hall Element Location

7.4 Device Functional Modes

The TMAG5233 always operates in a duty-cycled mode as described in the [Timing](#) section when the [Recommended Operating Conditions](#) are met.

8 Application and Implementation

注

Information in the following applications sections is not part of the TI component specification, and TI does not warrant its accuracy or completeness. TI's customers are responsible for determining suitability of components for their purposes, as well as validating and testing their design implementation to confirm system functionality.

8.1 Application Information

The TMAG5233 is a Hall-effect switch used to detect the proximity of a magnet, which is often attached to a movable component within the system. When the magnet comes sufficiently close to the sensor and induces a magnetic flux density that exceeds the B_{OP} threshold along the TMAG5233 axis of sensitivity, the output of the sensor is pulled low to GND. This low output can be read by a GPIO pin on a controller, enabling the system to recognize that the magnet has crossed the threshold, thereby indicating the position or movement of the component. This application is common in various fields, such as industrial automation and consumer electronics, where precise detection of position or movement is critical.

Due to the complex, non-linear behavior of magnets, it may be difficult to determine the appropriate magnet characteristics required to ensure the system works as intended. Therefore, TI recommends to begin the design process with experimentation to solve for a design that will work. To help facilitate rapid design iteration, the *TI Magnetic Sense Simulator (TIMSS)* web tool provides a visual interface that emulates typical sensor performance in system designs. TIMSS simulations provide an understanding of expected magnetic field behavior across a range of motion, and the simulations are run in a few seconds.

8.2 Typical Application



図 8-1. Typical Application Schematic

8.2.1 Design Requirements

This section provides an example using the *TI Magnetic Sense Simulator (TIMSS)* web tool for a magnet slide-by application. 表 8-1 lists the design parameters related to the magnet's movement on the X-axis as seen in 図 8-2 and 図 8-3.

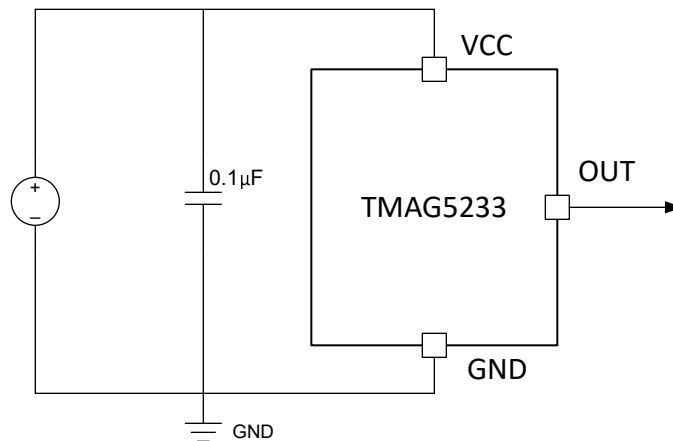

図 8-2. Side View



図 8-3. Top View

表 8-1. Design Parameters

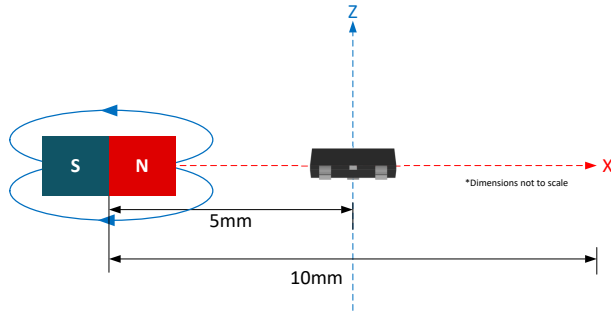
PARAMETER	VALUE
Supply voltage (V_{CC})	3.3V
Bypass capacitor	0.1 μ F
Part number	TMAG5233D1EDBVR
Magnet range of motion	10mm
Magnet length	3mm
Magnet width	3mm
Magnet height	3mm
Magnet type	N35

8.2.2 Detailed Design Procedure

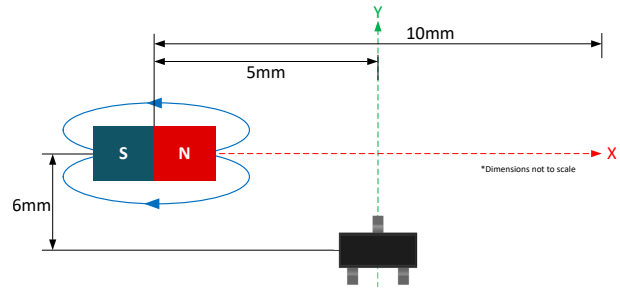
As the magnet travels from the starting position (–5mm on X-axis) to the final position (5mm on X-axis), the magnetic flux density seen by the TMAG5233 across the axis of sensitivity changes (see 図 8-4). 図 8-5 shows the TMAG5233 output across the same interval.

At the magnet starting position, the TMAG5233 output is high because the magnetic flux density is less than B_{OP} . As the magnet moves along the X-axis towards the sensor, the magnetic flux density crosses the B_{OP} threshold of the TMAG5233 at a displacement of –3.1mm, making the output go low. As the magnet continues to move along the X-axis past the origin, the magnetic flux density begins to decrease. At a displacement of 3.4mm the B_{RP} threshold is crossed and the output goes high.

8.2.3 Application Curves



図 8-4. Magnetic Flux Density vs Magnet Displacement



図 8-5. Output Voltage vs Magnet Displacement

8.3 Power Supply Recommendations

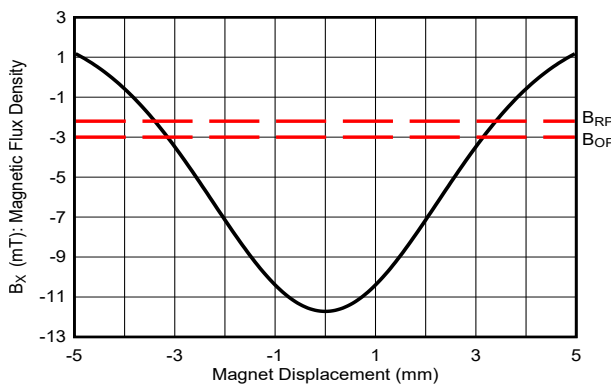
The TMAG5233 is powered on by supplying voltage to the V_{CC} pin in the range of 1.65V to 5.5V. TI recommends a bypass capacitor of at least $0.1\mu\text{F}$ between the sensor power supply and ground to help filter out voltage fluctuations and noise in the power supply. Best practice is to place this bypass capacitor as close to the supply pin of the sensor as possible.

8.4 Layout

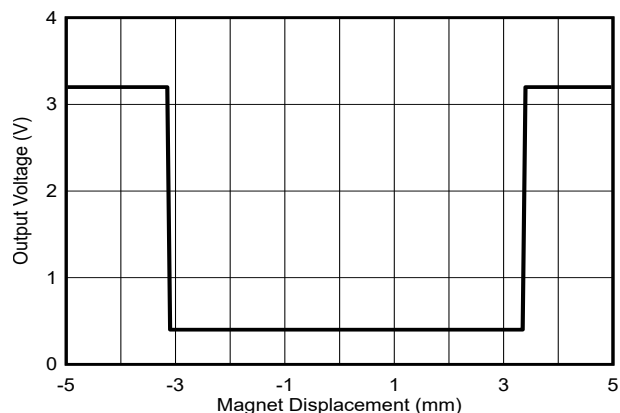
8.4.1 Layout Guidelines

Magnetic fields pass through most non-ferromagnetic materials with no significant disturbance. Embedding Hall effect sensors within plastic or aluminum enclosures and sensing magnets on the outside is common practice. Magnetic fields also easily pass through most printed circuit boards (PCBs), which makes the placement of the magnet on the opposite side of the board possible.

8.4.2 Layout Example



図 8-6. SOT-23 Layout Example

9 Device and Documentation Support

TI offers an extensive line of development tools. Tools and software to evaluate the performance of the device, generate code, and develop solutions are listed on the [TMAG5233 product folder](#).

9.1 Device Nomenclature

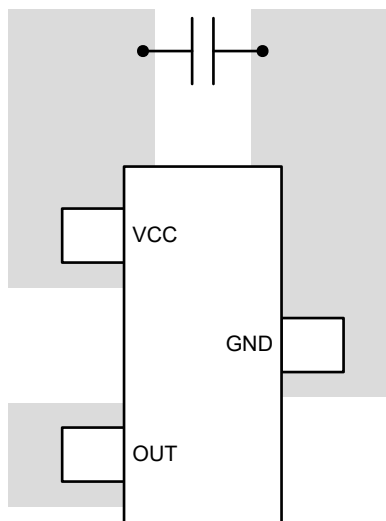
☒ 9-1 shows a legend for reading the complete orderable part numbers for the TMAG5233.

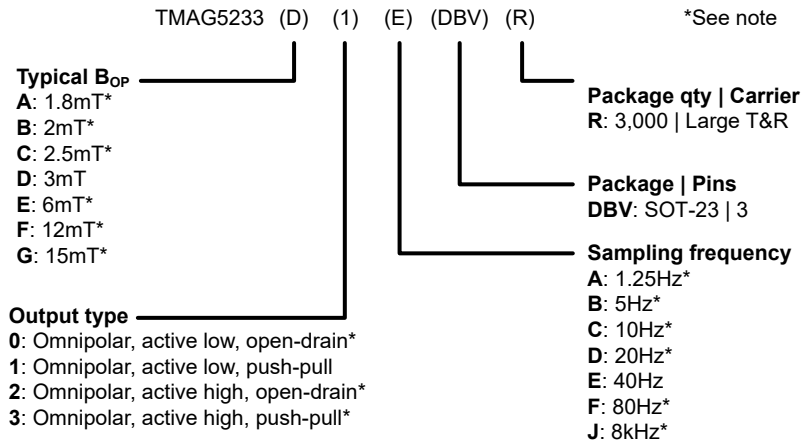

☒ 9-1. Device Nomenclature

注

Device version in preview, not released. For additional magnetic threshold, output type, and frequency versions please contact your local Texas Instruments representative.

9.2 ドキュメントの更新通知を受け取る方法

ドキュメントの更新についての通知を受け取るには、www.tij.co.jp のデバイス製品フォルダを開いてください。[通知] をクリックして登録すると、変更されたすべての製品情報に関するダイジェストを毎週受け取ることができます。変更の詳細については、改訂されたドキュメントに含まれている改訂履歴をご覧ください。

9.3 サポート・リソース

テキサス・インスツルメンツ E2E™ サポート・フォーラムは、エンジニアが検証済みの回答と設計に関するヒントをエキスパートから迅速かつ直接得ることができる場所です。既存の回答を検索したり、独自の質問をしたりすることで、設計に必要な支援を迅速に得ることができます。

リンクされているコンテンツは、各寄稿者により「現状のまま」提供されるものです。これらはテキサス・インスツルメンツの仕様を構成するものではなく、必ずしもテキサス・インスツルメンツの見解を反映したものではありません。テキサス・インスツルメンツの[使用条件](#)を参照してください。

9.4 静電気放電に関する注意事項



この IC は、ESD によって破損する可能性があります。テキサス・インスツルメンツは、IC を取り扱う際には常に適切な注意を払うことを推奨します。正しい取り扱いおよび設置手順に従わない場合、デバイスを破損するおそれがあります。

ESD による破損は、わずかな性能低下からデバイスの完全な故障まで多岐にわたります。精密な IC の場合、パラメータがわずかに変化するだけで公表されている仕様から外れる可能性があるため、破損が発生しやすくなっています。

9.5 用語集

[テキサス・インスツルメンツ用語集](#)

この用語集には、用語や略語の一覧および定義が記載されています。

10 Revision History

資料番号末尾の英字は改訂を表しています。その改訂履歴は英語版に準じています。

Changes from Revision * (August 2024) to Revision A (September 2024)	Page
• データシートのステータスを「事前情報」から「量産データ」.....	1

11 Mechanical, Packaging, and Orderable Information

The following pages include mechanical, packaging, and orderable information. This information is the most current data available for the designated devices. This data is subject to change without notice and revision of this document. For browser-based versions of this data sheet, refer to the left-hand navigation.

重要なお知らせと免責事項

テキサス・インスツルメンツは、技術データと信頼性データ (データシートを含みます)、設計リソース (リファレンス デザインを含みます)、アプリケーションや設計に関する各種アドバイス、Web ツール、安全性情報、その他のリソースを、欠陥が存在する可能性のある「現状のまま」提供しており、商品性および特定目的に対する適合性の黙示保証、第三者の知的財産権の非侵害保証を含むいかなる保証も、明示的または黙示的にかかわらず拒否します。

これらのリソースは、テキサス・インスツルメンツ製品を使用する設計の経験を積んだ開発者への提供を意図したものです。(1) お客様のアプリケーションに適した テキサス・インスツルメンツ製品の選定、(2) お客様のアプリケーションの設計、検証、試験、(3) お客様のアプリケーションに該当する各種規格や、その他のあらゆる安全性、セキュリティ、規制、または他の要件への確実な適合に関する責任を、お客様のみが単独で負うものとします。

上記の各種リソースは、予告なく変更される可能性があります。これらのリソースは、リソースで説明されている テキサス・インスツルメンツ製品を使用するアプリケーションの開発の目的でのみ、テキサス・インスツルメンツはその使用をお客様に許諾します。これらのリソースに関して、他の目的で複製することや掲載することは禁止されています。テキサス・インスツルメンツや第三者の知的財産権のライセンスが付与されている訳ではありません。お客様は、これらのリソースを自身で使用した結果発生するあらゆる申し立て、損害、費用、損失、責任について、テキサス・インスツルメンツおよびその代理人を完全に補償するものとし、テキサス・インスツルメンツは一切の責任を拒否します。

テキサス・インスツルメンツの製品は、[テキサス・インスツルメンツの販売条件](#)、または [ti.com](https://www.ti.com) やかかる テキサス・インスツルメンツ製品の関連資料などのいずれかを通じて提供する適用可能な条項の下で提供されています。テキサス・インスツルメンツがこれらのリソースを提供することは、適用されるテキサス・インスツルメンツの保証または他の保証の放棄の拡大や変更を意味するものではありません。

お客様がいかなる追加条項または代替条項を提案した場合でも、テキサス・インスツルメンツはそれらに異議を唱え、拒否します。

郵送先住所: Texas Instruments, Post Office Box 655303, Dallas, Texas 75265

Copyright © 2024, Texas Instruments Incorporated

PACKAGING INFORMATION

Orderable Device	Status (1)	Package Type	Package Drawing	Pins	Package Qty	Eco Plan (2)	Lead finish/ Ball material (6)	MSL Peak Temp (3)	Op Temp (°C)	Device Marking (4/5)	Samples
TMAG5233D1EDBVR	ACTIVE	SOT-23	DBV	3	3000	RoHS & Green	SN	Level-1-260C-UNLIM	-40 to 125		Samples

(1) The marketing status values are defined as follows:

ACTIVE: Product device recommended for new designs.

LIFEBUY: TI has announced that the device will be discontinued, and a lifetime-buy period is in effect.

NRND: Not recommended for new designs. Device is in production to support existing customers, but TI does not recommend using this part in a new design.

PREVIEW: Device has been announced but is not in production. Samples may or may not be available.

OBSOLETE: TI has discontinued the production of the device.

(2) **RoHS:** TI defines "RoHS" to mean semiconductor products that are compliant with the current EU RoHS requirements for all 10 RoHS substances, including the requirement that RoHS substance do not exceed 0.1% by weight in homogeneous materials. Where designed to be soldered at high temperatures, "RoHS" products are suitable for use in specified lead-free processes. TI may reference these types of products as "Pb-Free".

RoHS Exempt: TI defines "RoHS Exempt" to mean products that contain lead but are compliant with EU RoHS pursuant to a specific EU RoHS exemption.

Green: TI defines "Green" to mean the content of Chlorine (Cl) and Bromine (Br) based flame retardants meet JS709B low halogen requirements of <=1000ppm threshold. Antimony trioxide based flame retardants must also meet the <=1000ppm threshold requirement.

(3) MSL, Peak Temp. - The Moisture Sensitivity Level rating according to the JEDEC industry standard classifications, and peak solder temperature.

(4) There may be additional marking, which relates to the logo, the lot trace code information, or the environmental category on the device.

(5) Multiple Device Markings will be inside parentheses. Only one Device Marking contained in parentheses and separated by a "~" will appear on a device. If a line is indented then it is a continuation of the previous line and the two combined represent the entire Device Marking for that device.

(6) Lead finish/Ball material - Orderable Devices may have multiple material finish options. Finish options are separated by a vertical ruled line. Lead finish/Ball material values may wrap to two lines if the finish value exceeds the maximum column width.

Important Information and Disclaimer: The information provided on this page represents TI's knowledge and belief as of the date that it is provided. TI bases its knowledge and belief on information provided by third parties, and makes no representation or warranty as to the accuracy of such information. Efforts are underway to better integrate information from third parties. TI has taken and continues to take reasonable steps to provide representative and accurate information but may not have conducted destructive testing or chemical analysis on incoming materials and chemicals. TI and TI suppliers consider certain information to be proprietary, and thus CAS numbers and other limited information may not be available for release.

In no event shall TI's liability arising out of such information exceed the total purchase price of the TI part(s) at issue in this document sold by TI to Customer on an annual basis.

TAPE AND REEL INFORMATION

QUADRANT ASSIGNMENTS FOR PIN 1 ORIENTATION IN TAPE

*All dimensions are nominal

Device	Package Type	Package Drawing	Pins	SPQ	Reel Diameter (mm)	Reel Width W1 (mm)	A0 (mm)	B0 (mm)	K0 (mm)	P1 (mm)	W (mm)	Pin1 Quadrant
TMAG5233D1EDBVR	SOT-23	DBV	3	3000	178.0	9.0	3.3	3.2	1.4	4.0	8.0	Q3

TAPE AND REEL BOX DIMENSIONS

*All dimensions are nominal

Device	Package Type	Package Drawing	Pins	SPQ	Length (mm)	Width (mm)	Height (mm)
TMAG5233D1EDBVR	SOT-23	DBV	3	3000	190.0	190.0	30.0

EXAMPLE BOARD LAYOUT

DBV0003A

SOT-23 - 1.45 mm max height

SMALL OUTLINE TRANSISTOR

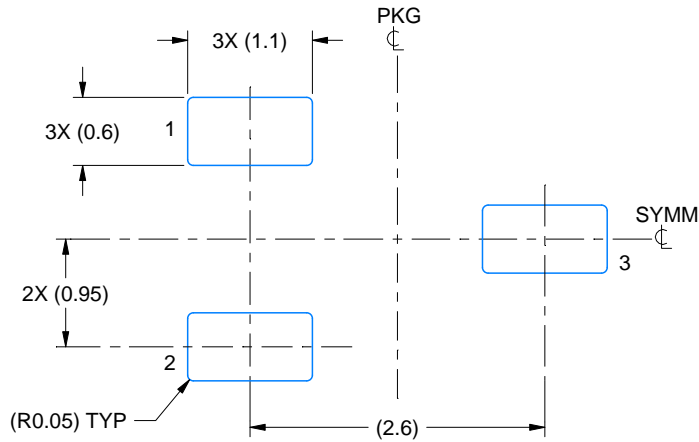

LAND PATTERN EXAMPLE
EXPOSED METAL SHOWN
SCALE:15X

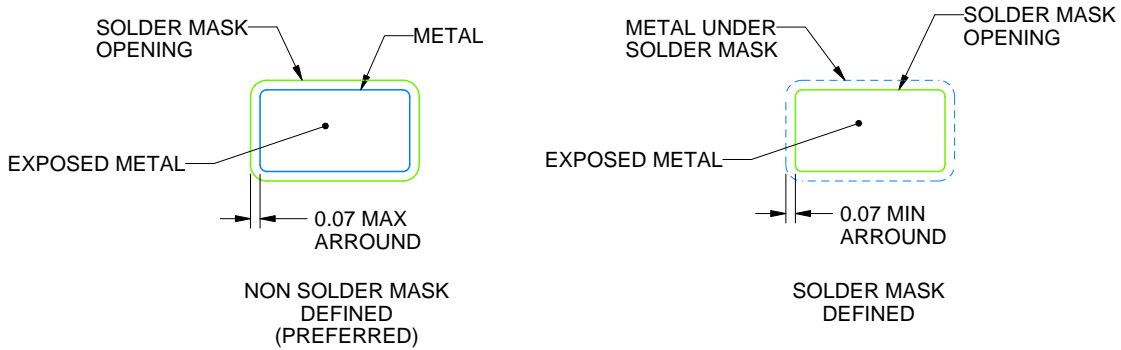

SOLDER MASK DETAILS

4220743/D 08/2024

NOTES: (continued)

- 6. Publication IPC-7351 may have alternate designs.
- 7. Solder mask tolerances between and around signal pads can vary based on board fabrication site.

EXAMPLE STENCIL DESIGN

DBV0003A

SOT-23 - 1.45 mm max height

SMALL OUTLINE TRANSISTOR

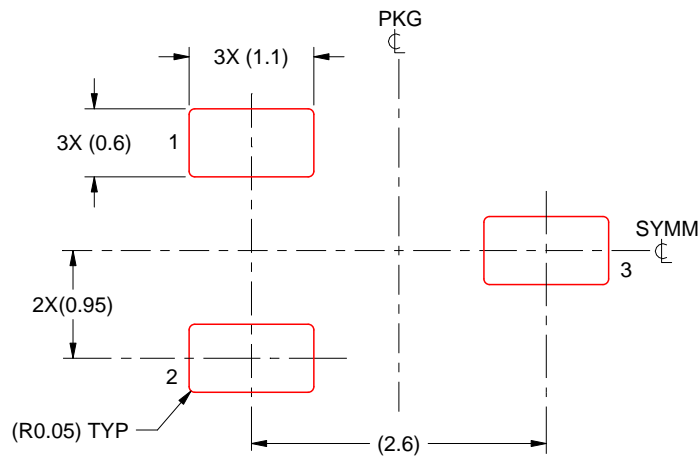

SOLDER PASTE EXAMPLE
BASED ON 0.125 mm THICK STENCIL
SCALE:15X

4220743/D 08/2024

NOTES: (continued)

8. Laser cutting apertures with trapezoidal walls and rounded corners may offer better paste release. IPC-7525 may have alternate design recommendations.
9. Board assembly site may have different recommendations for stencil design.

重要なお知らせと免責事項

TI は、技術データと信頼性データ(データシートを含みます)、設計リソース(リファレンス・デザインを含みます)、アプリケーションや設計に関する各種アドバイス、Web ツール、安全性情報、その他のリソースを、欠陥が存在する可能性のある「現状のまま」提供しており、商品性および特定目的に対する適合性の黙示保証、第三者の知的財産権の非侵害保証を含むいかなる保証も、明示的または黙示的にかかわらず拒否します。

これらのリソースは、TI 製品を使用する設計の経験を積んだ開発者への提供を意図したものです。(1) お客様のアプリケーションに適した TI 製品の選定、(2) お客様のアプリケーションの設計、検証、試験、(3) お客様のアプリケーションに該当する各種規格や、その他のあらゆる安全性、セキュリティ、規制、または他の要件への確実な適合に関する責任を、お客様のみが単独で負うものとします。

上記の各種リソースは、予告なく変更される可能性があります。これらのリソースは、リソースで説明されている TI 製品を使用するアプリケーションの開発の目的でのみ、TI はその使用をお客様に許諾します。これらのリソースに関して、他の目的で複製することや掲載することは禁止されています。TI や第三者の知的財産権のライセンスが付与されている訳ではありません。お客様は、これらのリソースを自身で使用した結果発生するあらゆる申し立て、損害、費用、損失、責任について、TI およびその代理人を完全に補償するものとし、TI は一切の責任を拒否します。

TI の製品は、[TI の販売条件](#)、または [ti.com](#) やかかる TI 製品の関連資料などのいずれかを通じて提供する適用可能な条項の下で提供されています。TI がこれらのリソースを提供することは、適用される TI の保証または他の保証の放棄の拡大や変更を意味するものではありません。

お客様がいかなる追加条項または代替条項を提案した場合でも、TI はそれらに異議を唱え、拒否します。

郵送先住所 : Texas Instruments, Post Office Box 655303, Dallas, Texas 75265
Copyright © 2024, Texas Instruments Incorporated