

# TMAG6181-Q1 高精度アナログ AMR 角度センサ、内蔵ターン・カウンタ付き

## 1 特長

- 車載アプリケーション用に AEC-Q100 認定済み:
  - 温度グレード 0: -40°C~150°C
- 機能安全準拠
  - 機能安全アプリケーション向けに開発
  - ASIL B までの ISO 26262 システム設計を支援するドキュメントを提供
- 高精度、小さい角度誤差の AMR センサ:
  - 0.1° (標準値)
  - 0.4° (3.3V、全温度範囲での最大値)
  - 0.56° (5.5V、全温度範囲での最大値)
- 高速 AMR 角度センサ:
  - 非常に低いレイテンシ 2μs 未満で最大 100krpm に対応
  - 角度範囲: 180°
- 角度ドリフトが小さいため、温度範囲全体にわたるキャリブレーションが不要です
- 広い動作磁界範囲: 20mT~1T
- 正弦波と余弦波の差動レシオメトリック アナログ出力
- 差動エンドまたはシングルエンドのアプリケーションをサポート
- 高速起動: < 40μs
- 内蔵のターン カウンタは、PWM 出力を使用して回転数をカウントします。
  - ターン カウンタをイネーブルにした状態で 50μA の低消費電力モード
  - インテリジェントな回転トラッキング機能により、低消費電力モードで最大 8krpm のトラッキングが可能
- スリープ モードに移行するための専用ピン: < 5μA
- 電源電圧範囲: 2.7V~5.5V

## 2 アプリケーション

- EPS モーター位置検出
- EPS ハンドル角度検出
- BLDC/PMSM モーター位置検出
- 電動自転車と二輪車
- ワイパーモジュールおよびアクチュエータ
- エンコーダ位置検出
- サーボドライブ位置センサ
- 一体型ベルト スタータ ジェネレータ

## 3 概要

TMAG6181-Q1 は、Anisotropic Magneto Resistive (AMR) テクノロジーをベースとする高精度角度センサです。このデバイスには、信号コンディショニング アンプが内蔵されており、印加される面内磁界の方向に関連する、正弦波と余弦の差動アナログ出力を提供します。また、X 軸と Y 軸に 2 つの独立したホール センサを搭載しており、回転の追跡に使用できます。

TMAG6181-Q1 は、動作磁界 (20mT~1T) の範囲が広いので、柔軟な機械的配置が可能であり、回転子位置センシングなどの高速アプリケーションに適した低レイテンシ (< 2μs) 出力を供給できます。起動時間 (< 40μs) が高速であり、スリープ ピンを使用してデバイスをスリープ モードおよび低消費電力ターン カウント モードの 2 つの低消費電力モードに移行できるため、低消費電力アプリケーションを実現できます。このデバイスには、回転数を追跡するためのターン カウンタが内蔵されており、TURNS ピンで PWM を使用してカウンタ値を送信します。

TMAG6181-Q1 は広範な診断機能を備え、機能安全アプリケーション向けに設計されています。このデバイスは、-40°C~150°Cの広い周囲温度範囲で一貫した動作を行い、熱ドリフトと寿命誤差を最小限に抑えます。

### パッケージ情報

部品番号	パッケージ (1)	パッケージ サイズ (2)
TMAG6181-Q1	DGK (VSSOP, 8)	3.00mm × 4.90mm

- 供給されているすべてのパッケージについては、[セクション 10](#) を参照してください。
- パッケージ サイズ (長さ × 幅) は公称値であり、該当する場合はピンも含まれます。

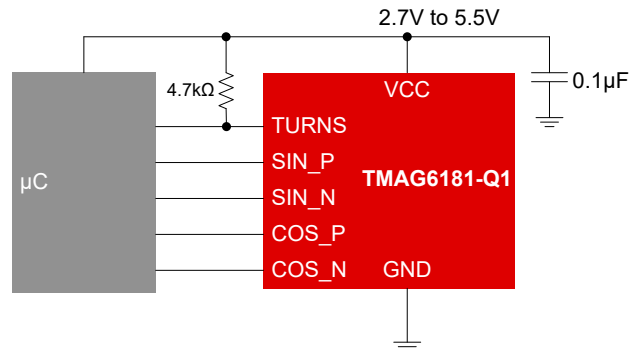

アプリケーション ブロック図



## Table of Contents

<b>1 特長</b> .....	1	6.4 Device Functional Modes.....	28
<b>2 アプリケーション</b> .....	1	<b>7 Application and Implementation</b> .....	30
<b>3 概要</b> .....	1	7.1 Application Information.....	30
<b>4 Pin Configuration and Functions</b> .....	3	7.2 Typical Application.....	32
<b>5 Specifications</b> .....	4	7.3 Power Supply Recommendations.....	37
5.1 Absolute Maximum Ratings.....	4	7.4 Layout.....	37
5.2 ESD Ratings.....	4	<b>8 Device and Documentation Support</b> .....	38
5.3 Recommended Operating Conditions.....	4	8.1 ドキュメントの更新通知を受け取る方法.....	38
5.4 Thermal Information.....	4	8.2 サポート・リソース.....	38
5.5 Electrical Characteristics.....	5	8.3 Trademarks.....	38
5.6 Magnetic Characteristics.....	7	8.4 静電気放電に関する注意事項.....	38
5.7 Typical Characteristics.....	8	8.5 用語集.....	38
<b>6 Detailed Description</b> .....	10	<b>9 Revision History</b> .....	38
6.1 Overview.....	10	<b>10 Mechanical, Packaging, and Orderable Information</b> .....	38
6.2 Functional Block Diagram.....	10		
6.3 Feature Description.....	11		

## 4 Pin Configuration and Functions



図 4-1. DGK Package 8-Pin VSSOP Top View

表 4-1. Pin Functions

PIN		TYPE <sup>(1)</sup>	DESCRIPTION
NO.	NAME		
1	COS_P	O	Differential cosine output (positive)
2	GND	G	Ground reference
3	COS_N	O	Differential cosine output (negative)
4	$\overline{\text{SLEEP}}$	I	$\overline{\text{SLEEP}}$ pin (active low)
5	TURNS	I/O	Turns counter output or Reset input (open drain)
6	SIN_N	O	Differential sine output (negative)
7	VCC	P	Power supply
8	SIN_P	O	Differential sine output (positive)

(1) I = input, O = output, I/O = input and output, G = ground, P = power

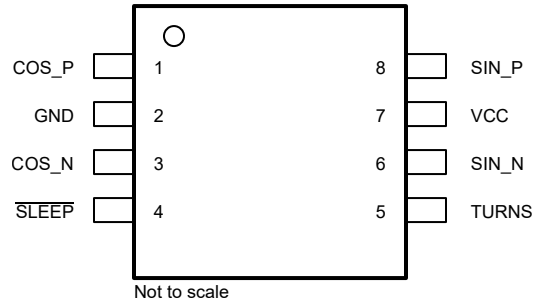
## 5 Specifications

### 5.1 Absolute Maximum Ratings

over operating free-air temperature range (unless otherwise noted)<sup>(1)</sup>

		MIN	MAX	UNIT
V <sub>CC</sub>	Main supply voltage	-0.3	7	V
I <sub>OUT</sub>	Output current (SIN_P, SIN_N, COS_P, COS_N, TURNS)	-10	10	mA
V <sub>OUT</sub>	Output voltage (SIN_P, SIN_N, COS_P, COS_N, TURNS)	-0.3	7	V
V <sub>IN</sub>	Input voltage SLEEP	-0.3	V <sub>VCC</sub> + 0.3	V
T <sub>J</sub>	Junction temperature	-40	170	°C
T <sub>stg</sub>	Storage temperature	-65	150	°C

- (1) Operation outside the Absolute Maximum Ratings may cause permanent device damage. Absolute maximum ratings do not imply functional operation of the device at these or any other conditions beyond those listed under Recommended Operating Conditions. If briefly operating outside the Recommended Operating Conditions but within the Absolute Maximum Ratings, the device may not sustain damage, but it may not be fully functional. Operating the device in this manner may affect device reliability, functionality, performance, and shorten the device lifetime.

### 5.2 ESD Ratings

			VALUE	UNIT
V <sub>(ESD)</sub>	Electrostatic discharge	Human body model (HBM), per AEC Q100-002 <sup>(1)</sup> HBM ESD classification level 2	±2000	V
		Charged device model (CDM), per AEC Q100-011	±500	
		CDM ESD classification level C4B	±750	

- (1) AEC Q100-002 indicates that HBM stressing shall be in accordance with the ANSI/ESDA/JEDEC JS-001 specification.

### 5.3 Recommended Operating Conditions

over operating free-air temperature range (unless otherwise noted)

		MIN	NOM	MAX	UNIT
V <sub>CC</sub>	Main supply voltage	2.7		5.5	V
T <sub>A</sub>	Operating free air temperature	-40		150	C
C <sub>L</sub>	Capacitive load on SIN_P, SIN_N, COS_P, COS_N	0.1		10	nF
I <sub>L</sub>	Current load on SIN_P, SIN_N, COS_P, COS_N	-1		1	mA
B	Magnetic flux density for AMR saturation	20			mT

### 5.4 Thermal Information

THERMAL METRIC <sup>(1)</sup>		TMAG6181-Q1	UNIT
		DGK (VSSOP)	
		8 PINS	
R <sub>θJA</sub>	Junction-to-ambient thermal resistance	166.8	°C/W
R <sub>θJC(top)</sub>	Junction-to-case (top) thermal resistance	57.8	°C/W
R <sub>θJB</sub>	Junction-to-board thermal resistance	88.7	°C/W
Ψ <sub>JT</sub>	Junction-to-top characterization parameter	7.0	°C/W
Ψ <sub>JB</sub>	Junction-to-board characterization parameter	87.1	°C/W

- (1) For more information about traditional and new thermal metrics, see the [Semiconductor and IC Package Thermal Metrics](#) application report.

## 5.5 Electrical Characteristics

over operating free-air temperature range (unless otherwise noted); typical specifications are at  $T_A = 25^\circ\text{C}$

PARAMETER		TEST CONDITIONS	MIN	TYP	MAX	UNIT
<b>AMR Output Parameters</b>						
$V_{out}$	Single-ended output voltage peak to peak	$V_{CC} = 3.3\text{V}$	57	62	67.5	% $V_{CC}$
		$V_{CC} = 5.5\text{V}$	55	60	65	
k	Amplitude asynchronism ratio (Vpk Cos/ Vpk Vsin)	$B = 30\text{mT}, V_{CC} = 3.3\text{V}$	-2.3	0.3	2.3	%
		$B = 30\text{mT}, V_{CC} = 5\text{V}$	-2.4	0.3	2.4	
$V_{offset\_room}^{(1)}$	Differential offset of SIN/COS outputs at room	$B = 30\text{mT}, T_A = 25^\circ\text{C}, V_{CC} = 3.3\text{V}$	-56		56	mV
		$B = 30\text{mT}, T_A = 25^\circ\text{C}, V_{CC} = 5\text{V}$	-90		90	
$V_{offset\_tc}$	Temperature coefficient of differential offset voltage	$B = 30\text{mT}, V_{CC} = 3.3\text{V}$		$\pm 0.1$		mV/ $^\circ\text{C}$
		$B = 30\text{mT}, V_{CC} = 5\text{V}$		$\pm 0.1$		
$V_{CM}$	Common-mode output voltage	$B = 30\text{mT}, V_{CC} = 3.3\text{V}$	48	50	52	% $V_{CC}$
		$B = 30\text{mT}, V_{CC} = 5\text{V}$	48	50	52	
$V_{NOISE}$	Output referred noise (differential)	$B = 30\text{mT}, C_{load} = 100\text{pF}$		0.5		mV $_{rms}$
$R_{out}$	Series output resistance			55		$\Omega$
$R_{out\_sleep}$	Series output resistance during Sleep	$\overline{\text{SLEEP}} = \text{GND}$	1			M $\Omega$
$t_{agc\_update}^{(2)}$	Update rate of the automatic gain control	After $V_{out}$ reaching 60% of $V_{CC}$		1		s
<b>DC Power</b>						
$V_{CC\_UV}$	VCC undervoltage threshold			2.45	2.65	V
$V_{CC\_OV}$	VCC overvoltage threshold			5.9	6.36	
$I_{ACT}$	Active mode current from VCC	$\overline{\text{SLEEP}} = \text{VCC}$		5	10	mA
$I_{DCM\_SLEEP}$	Sleep mode current from VCC	DCM mode enabled		50		$\mu\text{A}$
$I_{SLEEP}$	Sleep mode current from VCC	$\overline{\text{SLEEP}} = \text{GND}$		4.5		$\mu\text{A}$
$I_{LP}$	Average current during low power mode from VCC	Low power DCM mode with turns counter enabled (no rotations detected)		50		$\mu\text{A}$
$t_{sleep\_no\_rotation}$	Sleep time during low power mode when the magnetic field is static (not rotating)	$B = 30\text{ mT}$		25		ms
$t_{on\_startup}$	Power-on time during start-up	To achieve 90% of output voltages after VCC has reached final value ( $C_{LOAD} = 100\text{pF}$ )		38	85	$\mu\text{s}$
$t_{on\_sleep}$	Power on time after $\overline{\text{SLEEP}}$ goes high	To achieve 90% of output voltages after $\overline{\text{SLEEP}} > V_{IH}$ ( $C_{LOAD} = 100\text{pF}$ )		45	50	$\mu\text{s}$
$t_{sleep\_pd}$	Time that $\overline{\text{SLEEP}}$ must stay low when transitioning from active mode to low power mode		125		400	$\mu\text{s}$
$t_{sleep\_timeout}$	Timeout between two consecutive pulses on $\overline{\text{SLEEP}}$ pin when entering low power mode		25		400	$\mu\text{s}$
$t_{sleep\_mode}$	Time that $\overline{\text{SLEEP}}$ must stay low to enter sleep mode		1.1			ms
<b>Digital I/O</b>						
$V_{IH}$	High level input voltage	$\overline{\text{SLEEP}}$	$0.65 \times V_{CC}$			V
$V_{IL}$	Low level input voltage		$0.3 \times V_{CC}$			V

over operating free-air temperature range (unless otherwise noted); typical specifications are at  $T_A = 25^\circ\text{C}$ 

PARAMETER		TEST CONDITIONS	MIN	TYP	MAX	UNIT
$V_{IH}$	High level input voltage	TURNS	$0.65 \times V_{CC}$			V
$V_{IL}$	Low level input voltage				$0.3 \times V_{CC}$	V
$V_{OL}$	Low level output voltage	$I_O = 2\text{mA}$ on TURNS pin	0		0.4	V
<b>Turns Counter</b>						
$f_{PWM}$	PWM carrier frequency	When Turns Counter is enabled		2.5		KHz
$DC_{PWM}$	Output Valid Duty Cycle Range		10		90	%
TC	Turns Counter Range		-1024		1023	
TCstep	Turns Counter PWM Step Size			0.039		% / Turn
TC_PWM <sub>Q</sub>	Quiescent Duty Cycle	Turns Counter = 0		50		%
TC_PWM <sub>QΔL</sub>	Quiescent Duty Cycle Lifetime drift			0.5		%
TC <sub>noise</sub>	RMS noise on PWM duty cycle of TURNS pin			0.005		%
T <sub>tc_start</sub>	Minimum Time required to pull down the TURNS pin to initiate the turns counter				125	μs
T <sub>tc_reset</sub>	Minimum Time required to pull down the TURNS pin to reset the turns counter				1.1	ms
T <sub>tc_delay</sub>	Time delay from rising edge on TURNS pin to the first PWM falling edge			55		μs

- (1)  $V_{\text{offset\_room}}$  is the differential offset voltage deviation from the target of 0mV.
- (2) The AGC rate initially starts at 4μs on power-up. When  $V_{OUT}$  crosses 60% of  $V_{CC}$  the updated rate switches to 1s.

## 5.6 Magnetic Characteristics

over operating free-air temperature range (unless otherwise noted); typical specifications are at TA = 25°C

PARAMETER		TEST CONDITIONS	MIN	TYP	MAX	UNIT
<b>Angular Performance</b>						
ANG <sub>ERR_DYN_SE</sub>	Angular error linearity across temperature on continuous calibration (gain / offset) (single ended)	B = 30mT, V <sub>CC</sub> = 3.3V, Magnetic field Rotation Speed = 1000rpm		0.1	0.35	deg
		B = 30mT, V <sub>CC</sub> = 5V, Magnetic field Rotation Speed = 1000rpm		0.1	0.56	deg
ANG <sub>ERR_DYN_DE</sub>	Angular error linearity across temperature on continuous calibration (gain / offset) (differential ended)	B = 30mT, V <sub>CC</sub> = 3.3V, Magnetic field Rotation Speed = 1000rpm		0.1	0.4	deg
		B = 30mT, V <sub>CC</sub> = 5V, Magnetic field Rotation Speed = 1000rpm		0.1	0.56	deg
ANG <sub>ERR_RTCAL_SE</sub>	Angular error linearity across temperature after room temperature calibration (of offset / gain mismatch) (single ended)	B = 30mT, V <sub>CC</sub> = 3.3V, Ideal magnet alignment		0.1	1.1	deg
		B = 30mT, V <sub>CC</sub> = 5V, Ideal magnet alignment		0.1	1.1	deg
ANG <sub>ERR_RTCAL_DE</sub>	Angular error linearity across temperature after room temperature calibration (of offset / gain mismatch) (differential ended)	B = 30mT, V <sub>CC</sub> = 3.3V, Ideal magnet alignment		0.2	1.0	deg
		B = 30mT, V <sub>CC</sub> = 5V, Ideal magnet alignment		0.1	0.95	deg
ANG <sub>ERR_NOCAL_SE</sub>	Angular error linearity across temperature with no calibration of gain / offset (single ended)	B = 30mT, V <sub>CC</sub> = 3.3V, Ideal magnet alignment		0.5	1.52	deg
		B = 30mT, V <sub>CC</sub> = 5V, Ideal magnet alignment		0.5	1.26	deg
ANG <sub>ERR_NOCAL_DE</sub>	Angular error linearity across temperature with no calibration of gain / offset (differential ended)	B = 30mT, V <sub>CC</sub> = 3.3V, Ideal magnet alignment		0.4	1.1	deg
		B = 30mT, V <sub>CC</sub> = 5V, Ideal magnet alignment		0.4	1.0	deg
ANG <sub>LT_DRIFT</sub>	Angle error lifetime drift	B = 30mT		0.05	±0.75	deg
ANG <sub>HYST</sub>	Angle hysteresis error	B = 30mT		0.01	0.06	deg
ANG <sub>OE_ERR</sub>	Orthogonality error	B = 30mT		0.01	0.051	deg
ANG <sub>NOISE</sub>	Angular RMS (1-sigma) noise in degrees	B = 30mT, C <sub>load</sub> = 100pF		0.01	0.06	deg
t <sub>del_amr</sub>	Propagation Delay time	C <sub>load</sub> = 100pF		1.6		µs
BW <sub>3dB_amr</sub>	3-dB Bandwidth	C <sub>load</sub> = 100pF		100		KHz
φ <sub>err</sub>	Phase error	Magnetic Field Rotation Speed = 10000rpm, C <sub>load</sub> = 100pF		0.15		deg
<b>Hall sensor characteristics</b>						
B <sub>OP(X)</sub> , B <sub>OP(Y)</sub>	Magnetic field operating point			3		mT
B <sub>RP(X)</sub> , B <sub>RP(Y)</sub>	Magnetic field release point			-3		mT
B <sub>OP</sub> - B <sub>RP</sub>	Magnetic hysteresis			3.5	6	mT
B <sub>SYM_OP</sub>	Operating point symmetry	B <sub>op(x)</sub> – B <sub>op(y)</sub>		±0.5		mT
B <sub>SYM_RP</sub>	Release point symmetry	B <sub>rp(x)</sub> – B <sub>rp(y)</sub>		±0.5		mT
B <sub>SYM_RP</sub>	Release point symmetry	B <sub>rp(x)</sub> – B <sub>rp(y)</sub>		0		mT
t <sub>PD_HALL</sub>	Propagation delay time per channel	Change in B <sub>OP</sub> or B <sub>RP</sub> to change in output		10		µs

## 5.7 Typical Characteristics



图 5-1. Absolute Angle Error. Differential with Dynamic Calibration



图 5-2. Absolute Angle Error. Differential with Room Temperature Calibration

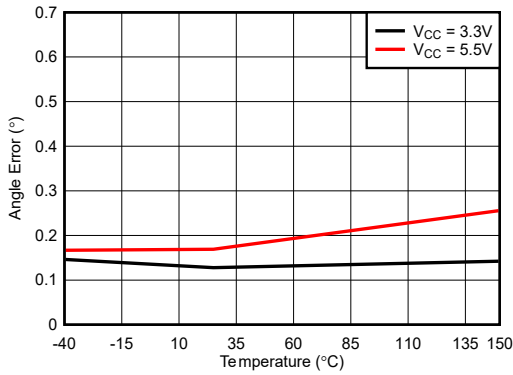

图 5-3. Absolute Angle Error. Differential with No Calibration

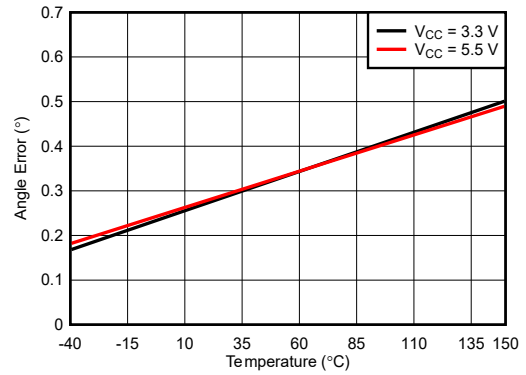

图 5-4. AMR Common-Mode Output Voltage

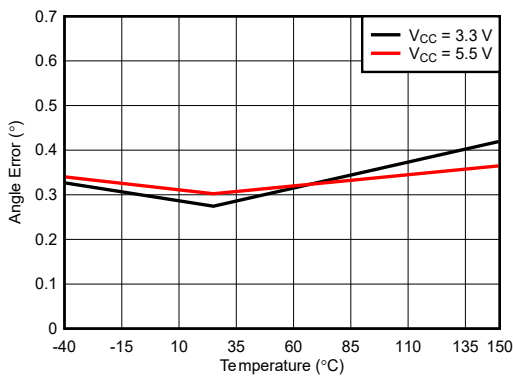

图 5-5. Hall Sensor BOP and BRP Typical Threshold

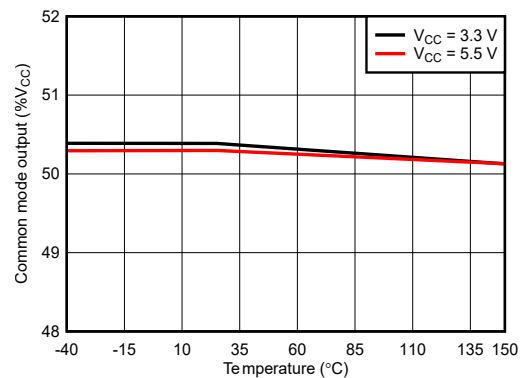

图 5-6. Active Mode Current

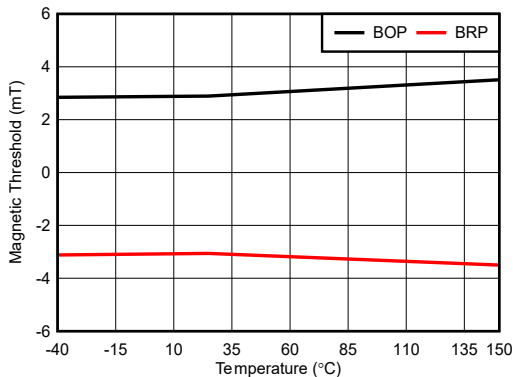

### 5.7 Typical Characteristics (continued)

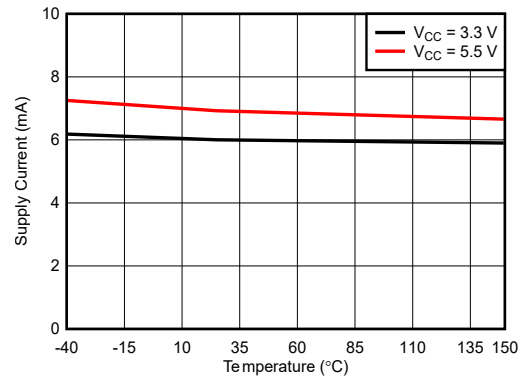
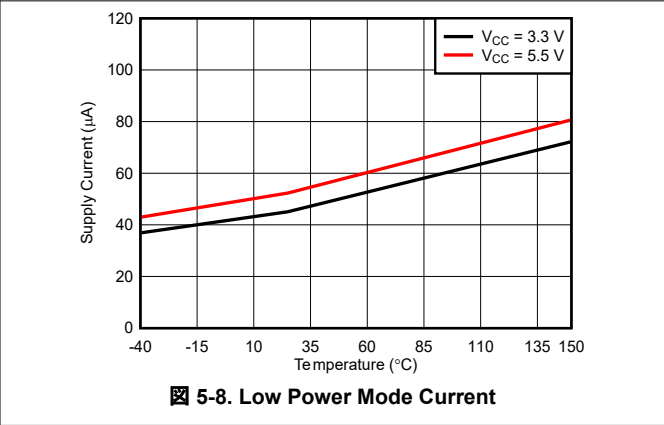
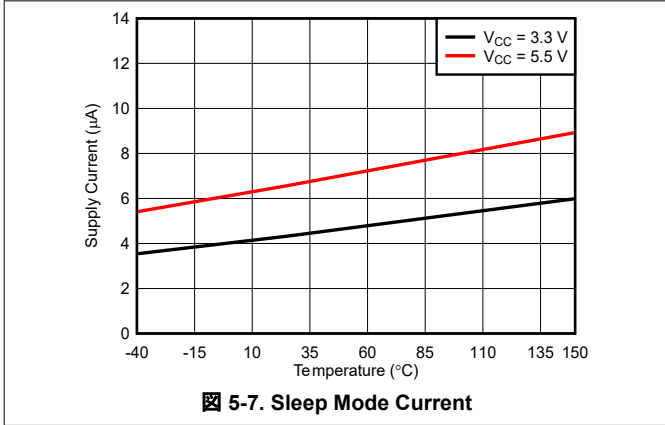

## 6 Detailed Description

### 6.1 Overview

The TMAG6181-Q1 is a high-precision angle sensor based on the AMR sensor technology vertically integrated on top of the integrated amplifiers on silicon. The differential output sine and cosine signals from the AMR sensor are proportional to the angle of the applied magnetic field. They are internally signal conditioned, temperature compensated, and driven by differential output amplifiers with the ability to drive large capacitive loads. The output voltages of the AMR sensor are ratiometric to the supply voltage so the external ADC can use the supply voltage as a reference.

The TMAG6181-Q1 features a  $\overline{\text{SLEEP}}$  pin to enable low power operation. The device integrates a rotation turns counter to measure the number of rotations of the external magnetic field using the integrated X and Y Hall sensors at a resolution of 90 degrees. The TURNS pin provides the integrated turns counter output using Pulse Width Modulation (PWM) scheme.

The TMAG6181-Q1 contains the following functional and building blocks:

- The Power Management and Oscillators block contains internal regulators, biasing circuitry, a low-frequency, wake-up oscillator and a high-frequency, wake-up oscillator, overvoltage and undervoltage detection circuitry
- The AMR sensor contains two Wheatstone bridges made of magnetic resistive sensors, each sensing one of the components of the applied magnetic field, the sine and the cosine components.
- The AMR sensing path contains the signal conditioning amplifiers, offset compensation, automatic gain control circuitry and the output drivers.
- The Turns Counting path contains the X and Y Hall sensors, related biasing circuitry, signal conditioning, logic comparators and a counter to keep track of rotations
- The Internal memory block supports the factory-programmed values
- The diagnostic blocks support background diagnostic checks of the internal circuitry

### 6.2 Functional Block Diagram

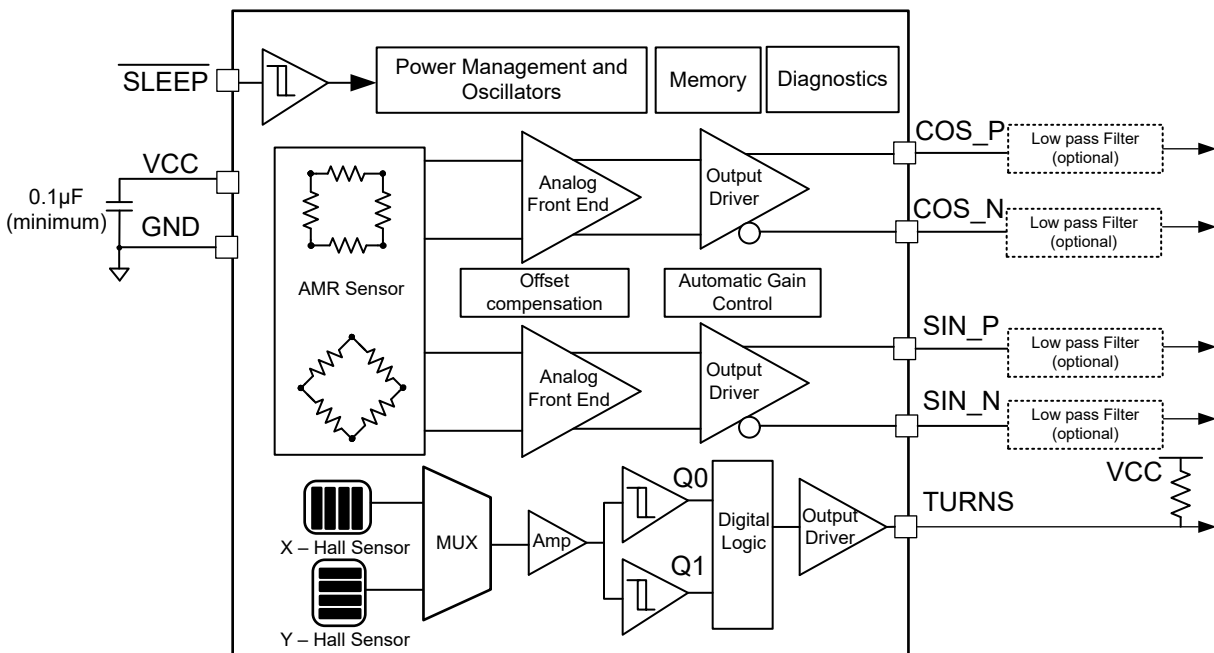

## 6.3 Feature Description

### 6.3.1 Magnetic Flux Direction

The TMAG6181-Q1 is sensitive to the magnetic field component in X and Y directions. The X and Y fields are in-plane with the package. The device generates sine and cosine outputs from the AMR based on the reference position ( $0^\circ$ ). See [Figure 6-1](#).

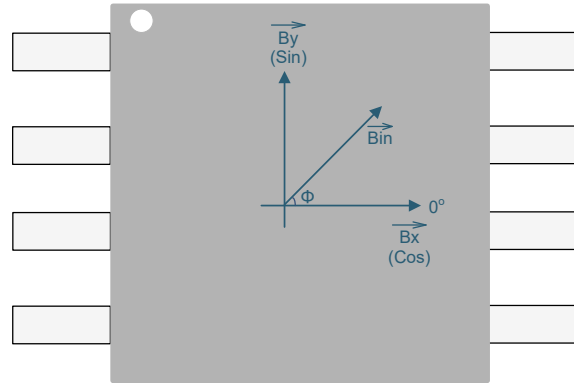

**Figure 6-1. Direction of Sensitivity**

### 6.3.2 Sensors Location and Placement Tolerances

Figure 6-2 shows the location of the AMR sensor and X, Y Hall elements, along with the placement tolerances inside the TMAG6181-Q1.

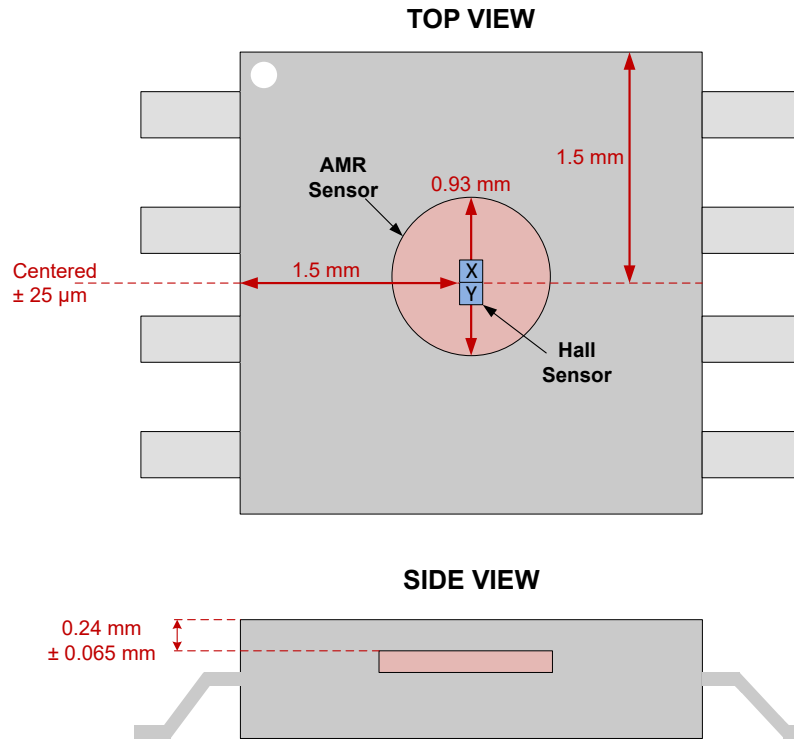

Figure 6-2. Location of AMR Sensor and Hall Elements

The center of the AMR and Hall sensors lie in the center of the package. Figure 6-3 shows the tolerances of the die rotation within the package. This causes a reference angle error ( $\Phi$ ) of  $\pm 3^\circ$ .

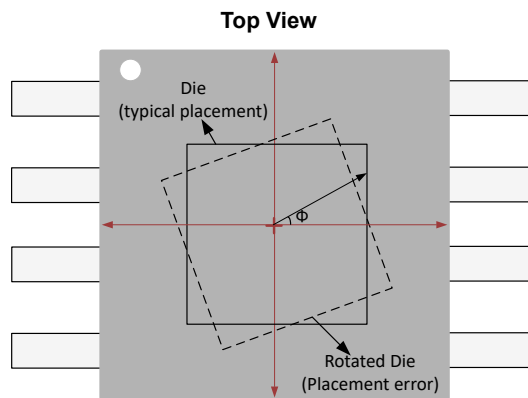

Figure 6-3. Die Rotation Tolerances in the Package

### 6.3.3 Magnetic Response

The AMR sensor has two components that are sensitive to the in-plane magnetic field X and Y axes parallel to the chip surface. Figure 6-4 shows the AMR sensor with the differential sine and cosine outputs SIN\_P, SIN\_N, COS\_P and COS\_N. The outputs have an electrical range of 180 degrees. If the mechanical angle between the sensor reference and the direction of the magnetic field is  $\theta$ , then the AMR outputs correspond to cosine  $2\theta$  and sine  $2\theta$ , respectively. For every  $360^\circ$  rotation of the external magnetic field, the AMR outputs provide two periods at  $180^\circ$  sensing range for each period. Hence, for a dipole magnet rotating at speed of  $f$ , the electrical output from the AMR sensor outputs can be at twice the frequency at  $2f$ . Use Equation 1 to calculate the angle of the magnetic field using an arctangent2 function.

$$\theta = \frac{\arctan2\left(\frac{V_{\sin}}{V_{\cos}}\right)}{2} \quad (1)$$

where

- $V_{\sin}$  is the sine output
- $V_{\cos}$  is the cosine output

The AMR sensor is sensitive only to the direction of the magnetic field and has a wide operating magnetic field range. The voltage levels of the AMR outputs are independent of the absolute flux density as long as the magnetic flux density is above the minimum recommended operating fields.

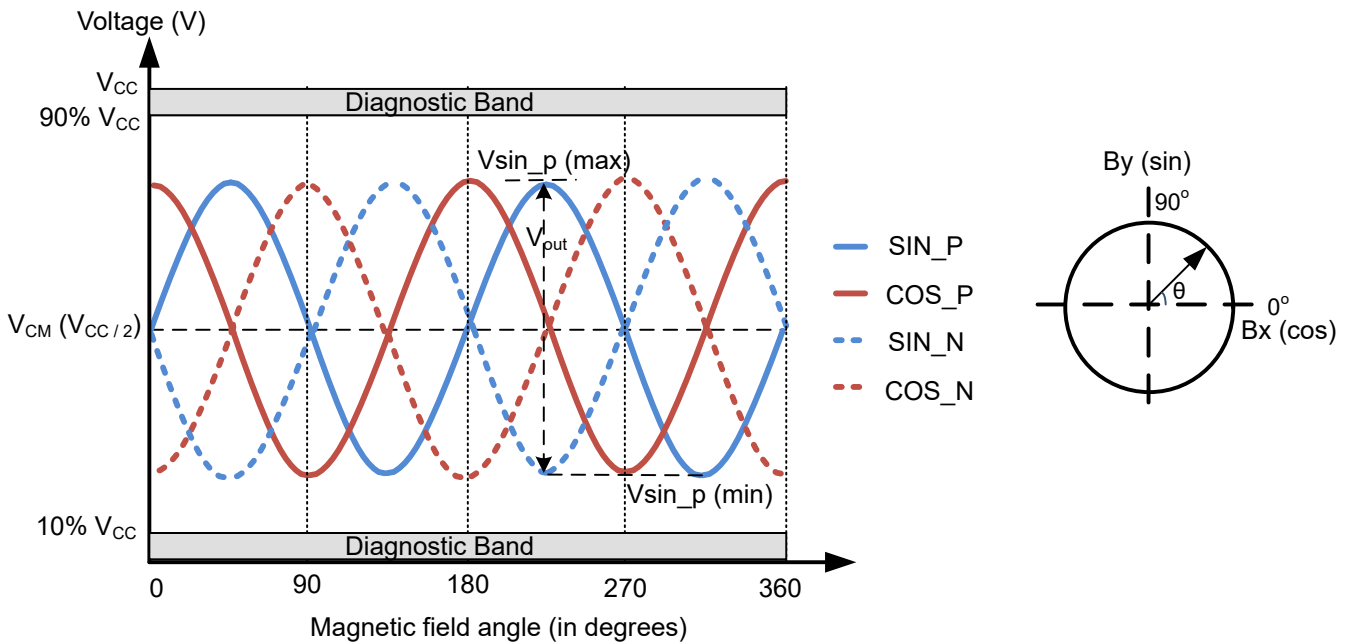

Figure 6-4. AMR Sensor Outputs Magnetic Response

Figure 6-5 shows the two integrated Hall sensors X and Y that are sensitive to the in-plane X and Y axes similar to the AMR sensor. The outputs Q1 and Q0 shows the digital outputs of both these sensors, respectively. Figure 6-5 shows both the Hall outputs reacting to the input field by going low when the field is higher than operating point ( $B_{OP}$ ) and going high when the field is lower than returning point ( $B_{RP}$ ).

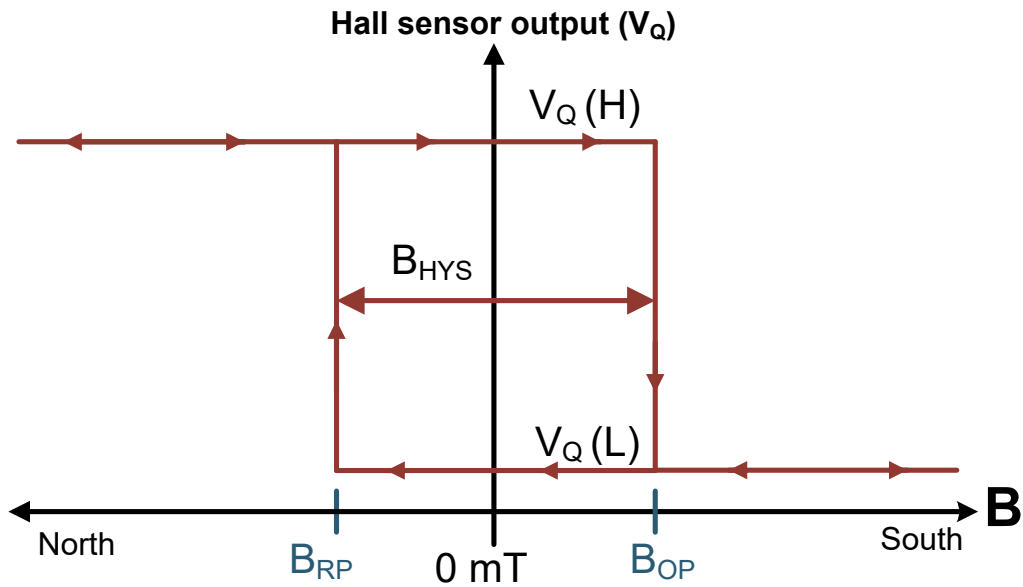

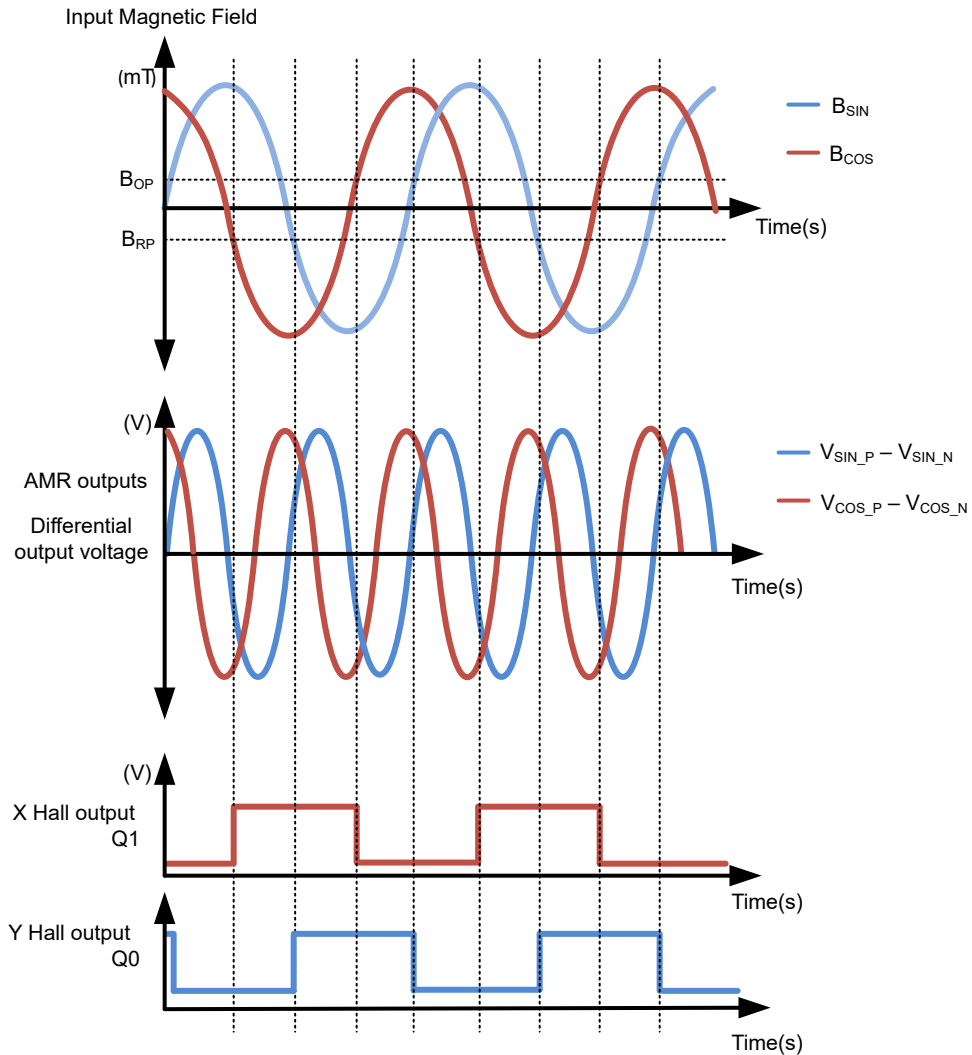

Figure 6-5. Hall Sensor Magnetic Response

For a rotating input magnetic field, with the Y and X components of  $B_{\text{SIN}}$  and  $B_{\text{COS}}$  respectively,  6-6 shows the response of the AMR and Hall sensors. The integrated X and Y Hall sensors provide digital outputs (Q1 and Q0, respectively). See the [Functional Block Diagram](#). The Hall sensors have a 360° angle range compared to the 180° angle range of the AMR sensors.



**図 6-6. Magnetic Response of AMR and Hall Sensors**

### 6.3.4 Parameters Definition

#### 6.3.4.1 AMR Output Parameters

**Magnetic Response** shows the single-ended output signals as SIN\_P, SIN\_N, COS\_P and COS\_N. These signals are ratiometric to the supply voltage ( $V_{CC}$ ). The common-mode voltage ( $V_{CM}$ ) of the individual signals is half of the supply voltage ( $V_{CC}/2$ ). For single-ended signals,  $V_{OUT}$  is defined as the difference between the maximum and minimum output voltage for a rotating magnetic field. Use 式 2 to calculate  $V_{OUT\_SIN\_P}$ .

$$V_{OUT\_SIN\_P} = V_{SIN\_P(max)} - V_{SIN\_P(min)} \quad (2)$$

where

- $V_{SIN\_P(max)}$  is the maximum output voltage across the full magnetic angle range
- $V_{SIN\_P(min)}$  is minimum output voltage across the full magnetic angle range

Typically,  $V_{OUT}$  is around 60% of the supply voltage ( $V_{CC}$ ). The diagnostic band indicates that the output signals are outside normal operating range and indicates a presence of fault.



図 6-7. AMR Differential-Ended Output Signals

图 6-7 shows the differential sine and cosine output signals generated from the corresponding sine and cosine single-ended outputs. Use 式 3 and 式 4 to calculate the differential voltages.

$$V_{sin\_diff} = V_{SIN\_P} - V_{SIN\_N} \quad (3)$$

$$V_{cos\_diff} = V_{COS\_P} - V_{COS\_N} \quad (4)$$

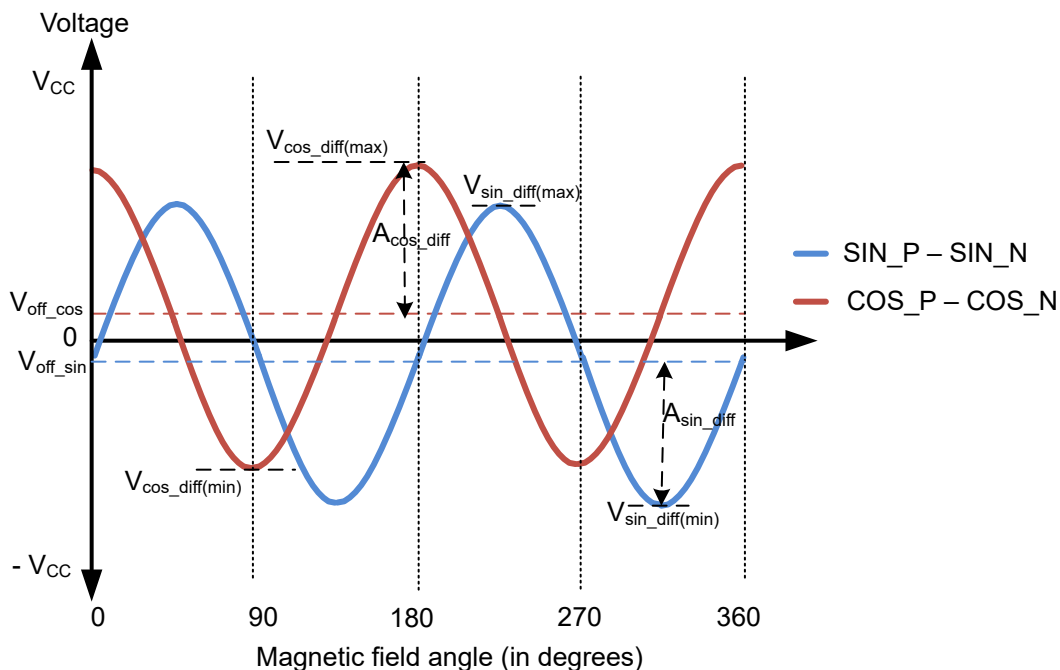
The offset of the differential signals is the average of the maximum and minimum voltages of the sine or cosine signals. Use 式 5 and 式 6 to calculate the offsets for the sine and cosine signals.

$$V_{offset\_sin} = \frac{V_{sin\_diff(max)} + V_{sin\_diff(min)}}{2} \quad (5)$$

$$V_{offset\_cos} = \frac{V_{cos\_diff(max)} + V_{cos\_diff(min)}}{2} \quad (6)$$



For single-ended signals, the offset is the common-mode voltage ( $V_{CM}$ ).

Use 式 7 to calculate the differential offset for sine and cosine channels at any given temperature,  $T_A$

$$V_{\text{offset}} = V_{\text{offset, room}} + V_{\text{offset\_TC}} \times (T_A - 25^\circ\text{C}) \quad (7)$$

where

- $V_{\text{Offset\_TC}}$  is the temperature drift coefficient of the offset
- $V_{\text{Offset\_room}}$  is the room temperature offset

Use 式 8 and 式 9 to calculate the amplitudes of the differential signals.

$$A_{\text{sin\_diff}} = \frac{V_{\text{sin\_diff(max)}} - V_{\text{sin\_diff(min)}}}{2} \quad (8)$$

$$A_{\text{cos\_diff}} = \frac{V_{\text{cos\_diff(max)}} - V_{\text{cos\_diff(min)}}}{2} \quad (9)$$

Use 式 10 to calculate the amplitude for single-ended signals.

$$A_{\text{sin\_p}} = \frac{V_{\text{sin\_p(max)}} - V_{\text{sin\_p(min)}}}{2} \quad (10)$$

Amplitude asynchronism refers to the amplitude mismatch error between sine and cosine channels. Use 式 11 to calculate the amplitude mismatch error.

$$k = 1 - \left( \frac{A_{\text{cos\_diff}}}{A_{\text{sin\_diff}}} \right) \quad (11)$$

The sine and cosine output signals are typically out-of-phase by 90 degrees, but if an internal phase error occurs owing to sensor and other on chip circuitry non-idealities, the sine and cosine outputs from the sensor can be different than the ideal 90 degrees. This error is referred to as the orthogonality error. This error is defined as the angle error between the zero crossing of the cosine output and maximum value of the sine outputs.

The hysteresis error ( $ANG_{\text{hyst}}$ ) refers to the largest angle error difference between a clockwise rotation and a counter-clockwise rotation.

For the AMR sensor, the orthogonality error and the hysteresis errors are negligible.

### 6.3.4.2 Transient Parameters

Propagation delay ( $t_{del\_amr}$ ) is defined as the time taken for signal to propagate from magnetic input change to the sine and cosine AMR outputs. The bandwidth limitation of the internal signal conditioning amplifiers causes a phase shift on the applied magnetic field. The propagation delay increases based on the speed of the rotating field and is specified at the maximum speed of the recommended magnetic field. 6-8 shows an input rotating magnetic field and the response of the AMR outputs. The propagation delay leads in the signal path leads to a phase error.



图 6-8. AMR Output Propagation Delay and Phase Error

The phase error ( $\phi_{err}$ ) refers to the angle error between the input magnetic field and output of the sensor. This error increases with the speed of the rotating magnetic field and the propagation delay of the AMR sensor. Typically this error can be compensated to the first order if the speed of the rotating magnetic field is known.

### 6.3.4.2.1 Power-On Time

The power-on time during start-up ( $T_{on\_startup}$ ) is defined as the time for the AMR outputs to reach to 90% of the final value (under a constant magnetic field) after the  $V_{CC}$  reaches  $V_{CC(min)}$ . 6-9 shows the power-on time of the device when the  $\overline{SLEEP}$  pin is tied to  $V_{CC}$  during a  $V_{CC}$  ramp.

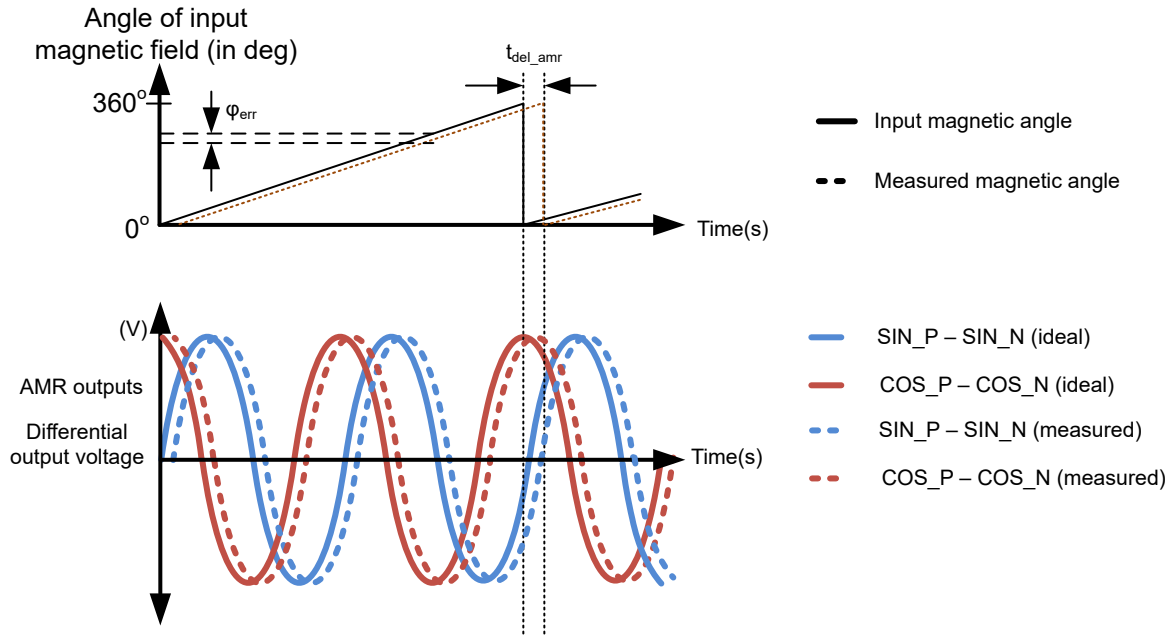
6-9. Power-On Time During Start-Up

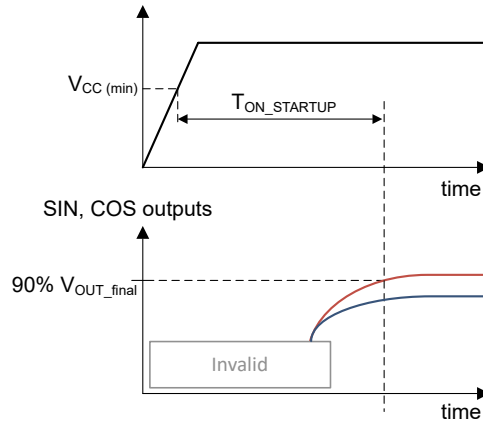

The power-on time from sleep mode ( $T_{on\_sleep}$ ) is defined as the time for the AMR outputs to reach to 90% of the final value (under a constant magnetic field) after the  $\overline{SLEEP}$  reaches above  $V_{IH\_SLEEP}$ . 6-10 shows the power-on time of the device when the  $\overline{SLEEP}$  pin is ramped high when the  $V_{CC}$  is held constant.

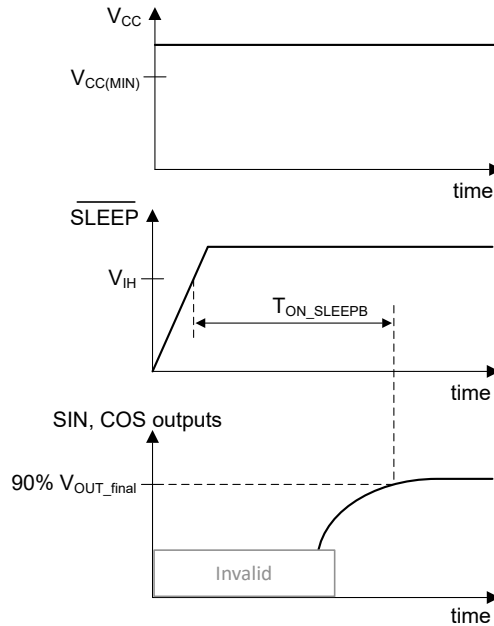

6-10. Power-On Time When  $\overline{SLEEP}$  is Pulled High

### 6.3.4.3 Hall Sensor Parameters

The Hall sensors X and Y have factory-calibrated operating ( $B_{OP}$ ) and release points ( $B_{RP}$ ). The operating and release points shown in [Figure 6-4](#) give the magnetic hysteresis for each Hall sensor.

Use [Equation 12](#) and [Equation 13](#) to calculate the symmetry point for each axis.

$$B_{SYM(X)} = B_{OP(X)} + B_{RP(X)} \quad (12)$$

where

- $B_{OP(X)}$  and  $B_{RP(X)}$  represent the operating and release points for X Hall sensor

$$B_{SYM(Y)} = B_{OP(Y)} + B_{RP(Y)} \quad (13)$$

where

- $B_{OP(Y)}$  and  $B_{RP(Y)}$  represent the operating and release points for Y Hall sensor

Use [Equation 14](#) to calculate the operating point symmetry.

$$B_{SYM\_OP} = B_{OP(X)} - B_{OP(Y)} \quad (14)$$

Use [Equation 15](#) to calculate the release point symmetry.

$$B_{SYM\_RP} = B_{RP(X)} - B_{RP(Y)} \quad (15)$$

### 6.3.4.4 Angle Accuracy Parameters

The overall angle error represents the relative angular error. [Figure 6-11](#) shows the deviation from the reference line after zero angle definition.

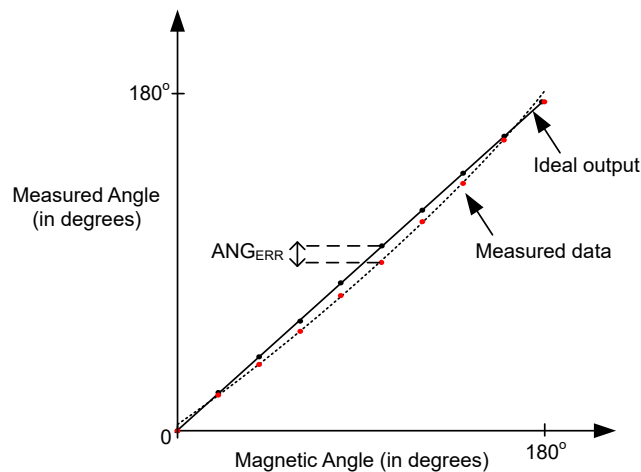

**Figure 6-11. Angle Error**

The uncalibrated angular error ( $ANG_{ERR\_NOCAL\_DE}$ ) is defined as the maximum deviation from an ideal angle without any offset and amplitude mismatch calibration for the VSIN and VCOS differential signals. For single-ended signals, the uncalibrated angular error is denoted by  $ANG_{ERR\_NOCAL\_SE}$ .

The single point calibration angular error ( $ANG_{ERR\_RTCAL\_DE}$ ) is defined as the maximum deviation from an ideal angle after the offset calibration is applied to the VSIN and VCOS differential signals at room temperature (25°C). For single-ended signals, the room temperature offset calibrated angular error is denoted by  $ANG_{ERR\_RTCAL\_SE}$ .

The dynamic angular error ( $ANG_{ERR\_DYN}$ ) is defined as the maximum deviation from an ideal angle with the continuous offset and gain calibration applied to the VSIN and VCOS differential signals. The error is measured at 1krpm and includes the phase error owing to the propagation delay of the AMR outputs.

### 6.3.5 Automatic Gain Control (AGC)

To reduce the drift of the AMR sensor outputs across temperature, the TMAG6181-Q1 features an automatic gain control circuitry where the device changes the gain of the output drivers to keep the final output within an appropriate voltage range on SIN\_P, SIN\_N, COS\_P and COS\_N. The AGC block uses the square root of the sum of the squared amplitudes of the two channels to sense amplitude of output signals and set gain selection. This means that the AGC block sets the gain for sine and cosine channels such that the peak-to-peak amplitude of single-ended voltages ( $V_{OUT}$ ) is within the range listed in [Specifications](#). The AGC block changes the gain of both the sine and cosine channels simultaneously and does not affect the angle accuracy.

If the outputs are out of the intended operating range, the AGC block changes the gain of the sine and cosine channels by a step size of  $\pm 1\% V_{CC}$  at an interval of  $t_{agc\_update}$ , approximately one second, as defined in [Specifications](#). [Figure 6-12](#) shows the differential AMR outputs for a continuously rotating input field. The shaded area represents the 'No AGC Control' band that represents  $\pm 5\%$  of  $V_{CC}$  and is centered at  $60\%$  of  $V_{CC}$ . Notice that the AGC loop reduces the gain of the sine and cosine channels and updates the amplitude of the sine and cosine signals when drift outside of the shaded region at a step size of  $1\% V_{CC}$ . If the outputs remain within the shaded region, then no action is taken by the AGC control loop.

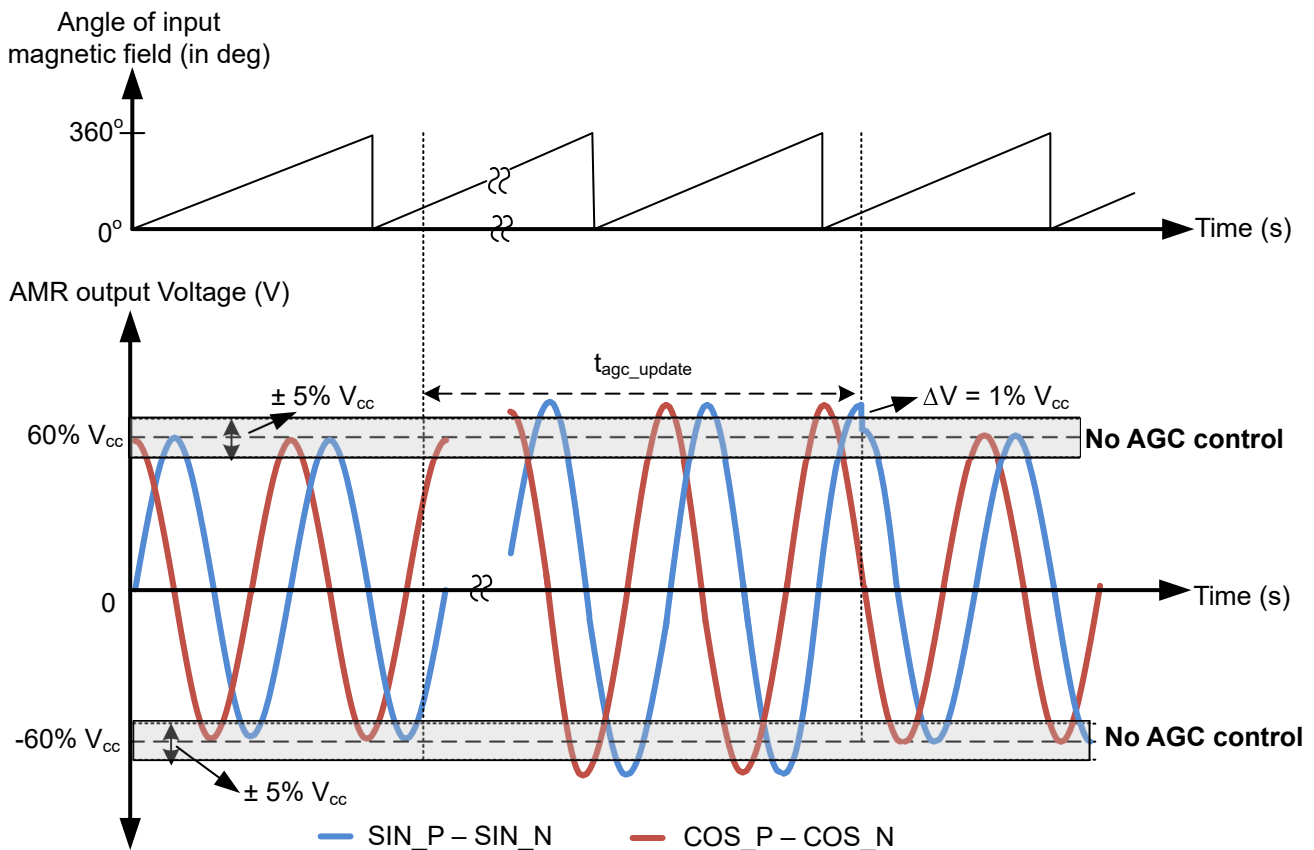
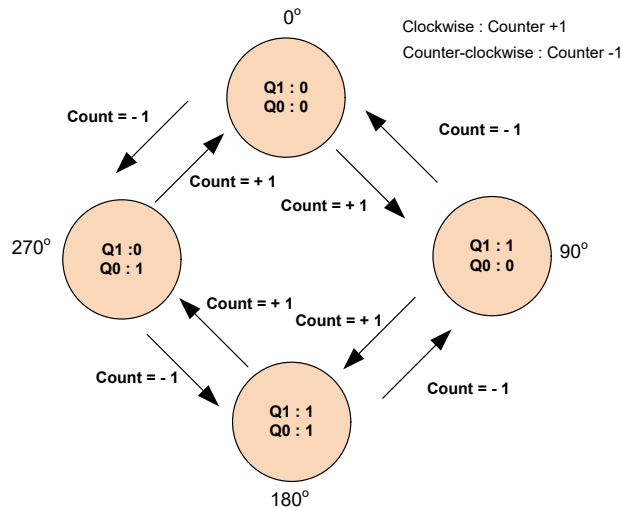

Figure 6-12. Timing Diagram Showing the Operation of Automatic Gain Control

### 6.3.6 Turns Counter

The TMAG6181-Q1 features an integrated 11-bit turns counter that can be used to keep track of rotation counts in different modes of operation (see [Device Functional Modes](#)). [Figure 7-2](#) shows the typical application diagram when the turns counter is used in the system. The turns counter can be initiated and reset using the open-drain TURNS pin.

The turns counter uses the integrated X and Y Hall sensors to detect the rotation. The outputs from the Hall sensors are sampled at an interval of  $t_{tc\_update}$  to update the turns counter. The turns counter can detect a change in the applied magnetic field at a resolution of  $90^\circ$  with a range of  $360^\circ$ . The turns counter also keeps track of direction information. The counter is incremented if the applied field is rotated clockwise and decremented if the field is rotated counter-clockwise. [Figure 6-13](#) shows the counter operation based on the rotation of the input magnetic field.



**Figure 6-13. Turns Counter Operation**

The turns counter information is sent using the TURNS pin in a Pulse Width Modulation (PWM) format. [Figure 6-14](#) shows the PWM duty cycle variation based on the turns counter value. The typical pulse-width modulation (PWM) carrier frequency is 2.5kHz. When the counter value is 0, the TURNS pin outputs a 50% duty cycle.

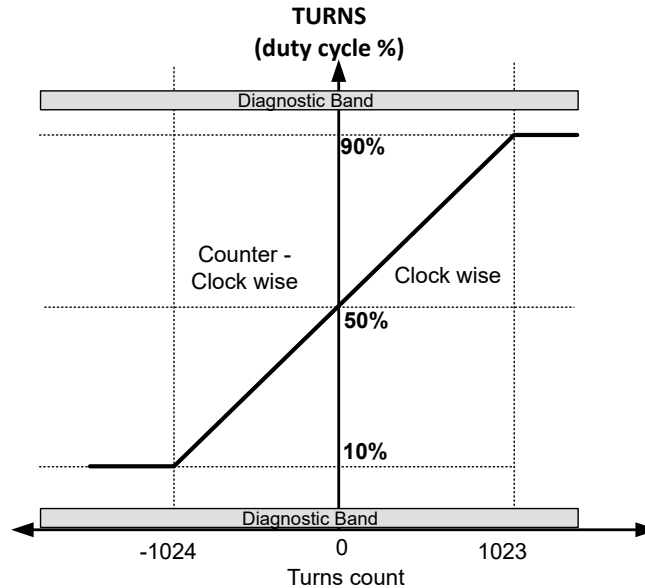

6-14. Turns Counter PWM Output on TURNS Pin

6-15 shows the timing diagram to enable the turns counter in active mode. When the part powers up, the turns counter is not enabled by default. The turns counter can be enabled by holding the TURNS pin low, for at least  $t_{tc\_start}$ . When the TURNS pin is released, the pin turns into the output mode and sends out the PWM pulses corresponding to the internal turns counter after a time delay of  $t_{tc\_delay}$ , as provided in the [Specifications](#). To reset the counter and disable the output on TURNS pin, TURNS is pulled low for at least  $t > t_{tc\_reset}$ . When the turns counter is enabled in the active mode, the internal wake-up oscillator is used to enable the Hall sensor signal path at regular intervals to update the turns counter information. This allows the device to keep the turns counter feature on at a lower power consumption overhead.

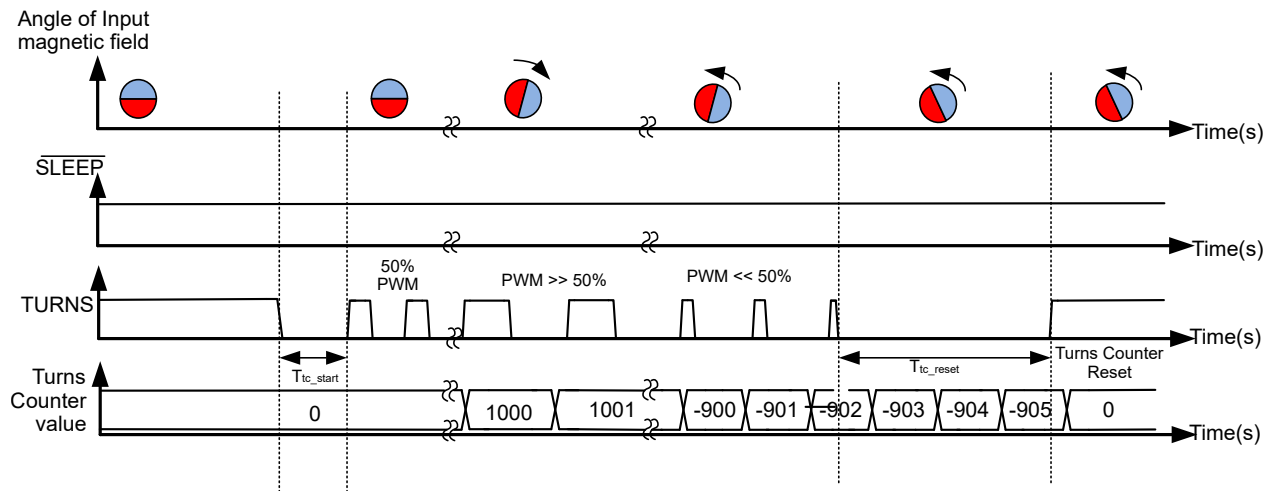

6-15. Timing Diagram Showing the Turns Counter Operation in Active Mode

6-16 shows the timing diagram of the turns counter operation in low-power mode. The part can be placed in a low-power, duty-cycled state if the turns counter is enabled. During this low-power state, an internal wake-up oscillator is used to wake up the device at regular intervals,  $t_{sleep}$ . When the part wakes up, the integrated Hall sensor signals are monitored for a rotation, and the turns counter information is updated. The TURNS pin does not output the PWM pulses during this low-power state. When the part is moved into an active state from the low-power state, the PWM pulses corresponding to the turns counter information saved during the low-power state is sent out to the microcontroller.



图 6-16. Timing Diagram Showing the Turns Counter Operation in Low-Power Mode

### 6.3.6.1 Rotation Tracking

The TMAG6181-Q1 has a rotation tracking feature to track high-speed rotations at low current consumption to save power. This feature lets the device decrease the sleep time when magnetic field rotations are detected, and enables the device to track the higher speed and acceleration events. When the turns counter is enabled using the TURNS pin, the rotation tracking feature is also enabled. This feature is enabled in both the active-turns mode and the low-power mode (see [Device Functional Modes](#) ).

In active mode, when the turns counter is enabled, the Hall sensor signals are monitored approximately every 1.6ms. But when a rotation is detected, the period between the next wake-up event is reduced by 1/8th to 0.2ms. If no rotation change is detected for four consecutive periods, then the sleep time is increased to 0.4ms. If new rotations are detected, then the tracking algorithm goes to 0.2ms and the counter for the four consecutive periods is reset. If no rotations are detected in next four consecutive periods, then the sleep time is doubled again to 0.8ms and then eventually back to 1.6ms if no more rotations are detected. After reaching this default value of 1.6ms, the rotation tracking feature allows the TMAG6181-Q1 to continue sampling at this fixed period until new rotations are detected.

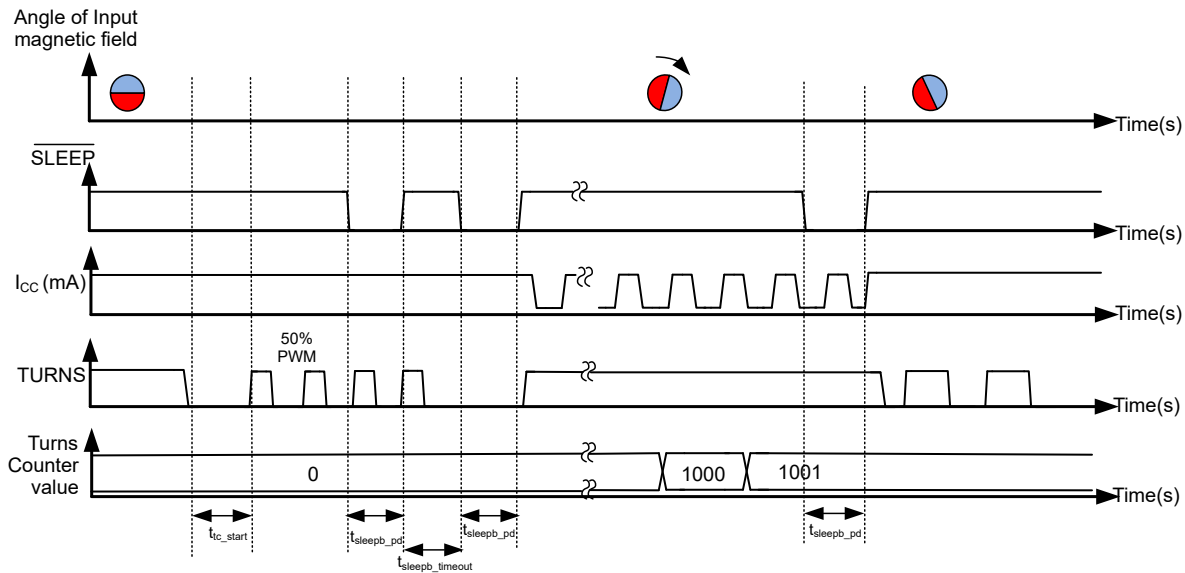
In low-power mode, when the turns counter is enabled, the Hall sensor signals are monitored approximately every 25.6ms. But when a rotation is detected, the period between the next wake-up event is reduced by 1/16th to 1.6ms. If no rotation change is detected for four consecutive periods, then the sleep time is increased to 3.2ms. If new rotations are detected, then the tracking algorithm goes to 1.6ms and the counter for the four consecutive periods is reset. If no rotations are detected in the next four consecutive periods, then the sleep time is doubled again to 6.4ms and then to 12.8ms after the next four cycles. After reaching the default value of 25.6ms, the rotation tracking feature allows the TMAG6181-Q1 to continue sampling at this fixed period until new rotations are detected. 图 6-17 shows the rotation tracking feature during low-power mode.





図 6-17. Timing Diagram Showing the Rotation Tracking Feature in Low Power Mode

Use 式 16 to calculate the maximum angle travel,  $\theta$ , for a rotating magnetic field.

$$\theta = 6[(v \times t) + (0.5 \times a \times t^2)] \quad (16)$$

where,

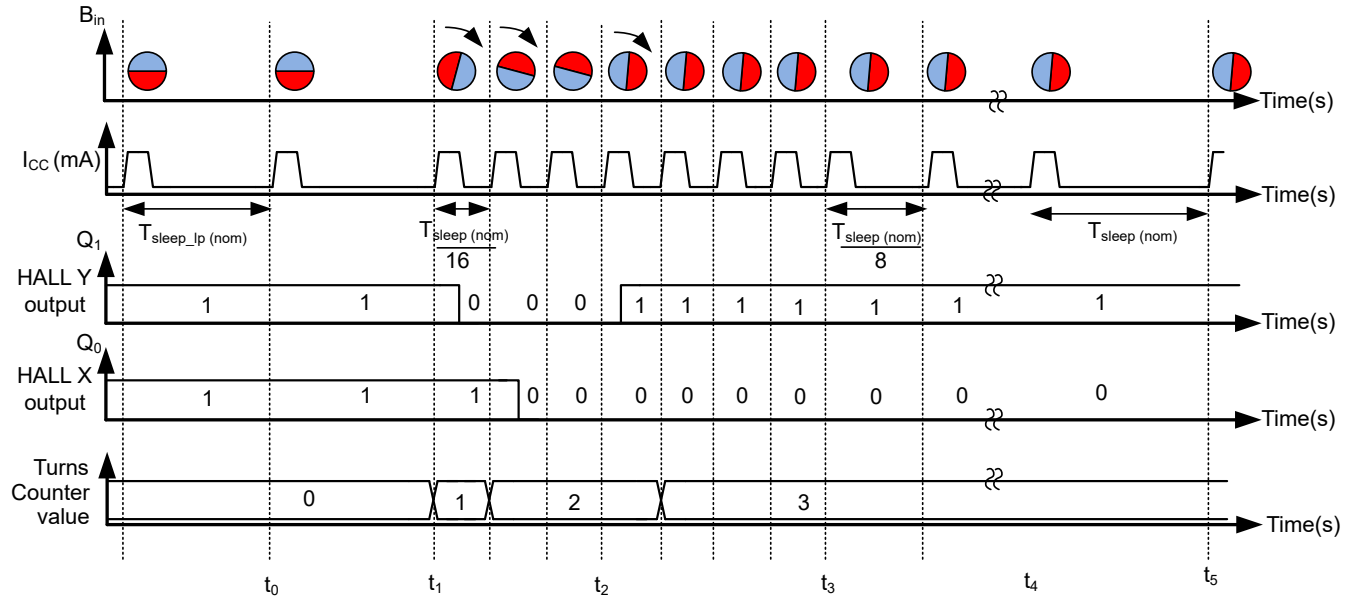
- $t$  is the field travel time
- $v$  is the velocity of the moving field in rpm
- $a$  is the acceleration of the moving field in rpm/second

The turns counter has an angle resolution of  $90^\circ$ . The turns counter can successfully track the rotations if the counter ensures the state transitions (as shown in 図 6-13) and does not jump any states. At an acceleration of 6000rpm/sec, the rotation tracking feature enables the device to track up to 8000rpm during low-power mode and in active-turns mode, and enables at track up to 60000rpm.

表 6-1 shows the trade-off between maximum speed (in rpm) that can be tracked by the turns counter and the current consumption in active mode.

**表 6-1. Maximum Trackable rpm vs Average Current Consumption in Active Mode**

OPERATING MODE	SLEEP TIME (ms)	MAX TRACKABLE rpm (TYP)	AVERAGE CURRENT ( $\mu$ A)
Active-turns mode	0.2	62500	472
	0.4	31250	280
	0.8	15625	167
	1.6 (default)	7812	105

表 6-2 shows the trade-off between maximum speed (in rpm) that can be tracked by the turns counter and the current consumption in low-power mode

**表 6-2. Maximum Trackable rpm vs Average Current Consumption in Low Power Mode**

OPERATING MODE	SLEEP TIME (ms)	MAX TRACKABLE rpm (TYP)	AVERAGE CURRENT (ILP) ( $\mu$ A)
Low-power mode	1.6	7812	105
	3.2	3905	73
	6.4	1950	57
	12.8	970	48
	25.6 (default)	475	44

### 6.3.7 Safety and Diagnostics

The TMAG6181-Q1 supports several device and system level diagnostics features to detect, monitor, and report failures during the device operation.

In the event of a failure, the TMAG6181-Q1 is placed in a FAULT state, where the outputs from the AMR sensors are placed in a high-impedance state. See [Device Functional Modes](#) for fault state transition from different operation modes. As shown in the [Application and Implementation](#) section, users can add pullup or pulldown resistors on SIN\_P, SIN\_N, COS\_P, and COS\_N pins at the termination site (that is the microcontroller). The resistors are generally pulled up to supply voltage or pulled down to ground such that the ADC code on MCU is out of expected range. This state signal faults to the microcontroller.

The integrated turns counter has a valid range of 10% to 90% PWM output. If a fault is detected in the turns counter, then the output of the turns counter is at >95% PWM or <5% PWM. The external microcontroller can monitor if the turns counter is within expected range.

The TMAG6181-Q1 performs the following device and system level checks:

#### 6.3.7.1 Device Level Checks

- AMR signal path checks
  - AMR sensor bias check
  - AMR output signals common mode check
  - Automatic gain control loop check
- Hall sensor signal path checks
  - Hall sensor bias and resistance check
  - Hall sensor comparator check
- Turns counter overflow check
- Power management and supporting circuitry checks
  - Internal LDO undervoltage check
  - Internal clocks integrity check
- Internal memory integrity check (or a cyclic redundancy check–CRC)

#### 6.3.7.2 System Level Checks

- V<sub>CC</sub> undervoltage and overvoltage checks
- Pin level opens and short checks

## 6.4 Device Functional Modes

### 6.4.1 Operating Modes

The TMAG6181-Q1 supports multiple operating modes for a wide array of applications as explained in [Figure 6-18](#). The device starts powering up after the  $V_{CC}$  supply crosses the minimum threshold as specified in the *Recommended Operating Conditions* table.



图 6-18. TMAG6181-Q1 State Transition Diagram

表 6-3 shows the different operating modes of the TMAG6181-Q1.

表 6-3. TMAG6181-Q1 Operating Modes

OPERATING MODE	DEVICE FUNCTION	AMR OUTPUT STATE	TURNS PIN (I/O FUNCTIONALITY) <sup>(1)</sup>
Active mode	AMR outputs track the magnetic field direction	Outputs in normal operating range	I
Active-turns mode	AMR outputs track the magnetic field direction and the TURNS pin sends out the internal turns counter information using PWM	Outputs in normal operating range	I / O
Low-power mode	Wakes up at a certain interval and the turns counter keeps track of changes in X and Y Hall sensor state	High Impedance	N/A
Sleep mode	Device enters the lowest power state	High Impedance	N/A

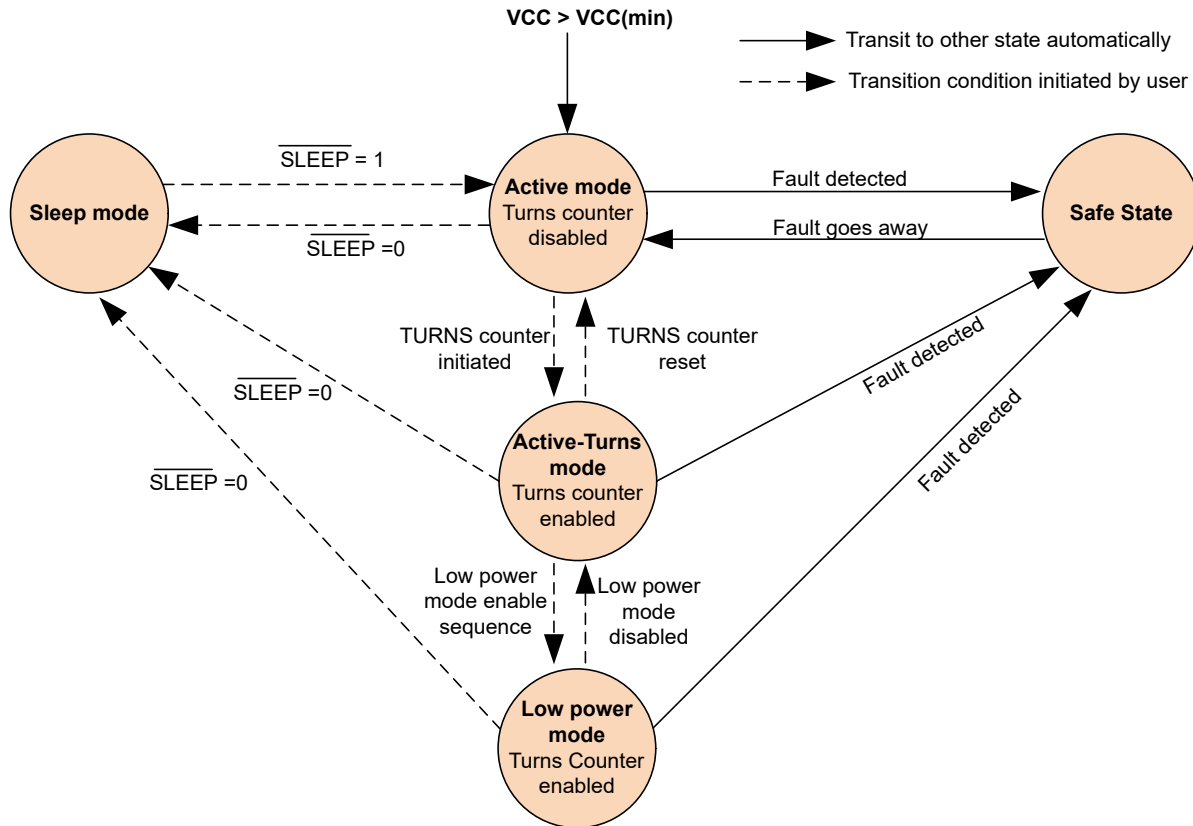
**表 6-3. TMAG6181-Q1 Operating Modes (続き)**

OPERATING MODE	DEVICE FUNCTION	AMR OUTPUT STATE	TURNS PIN (I/O FUNCTIONALITY) <sup>(1)</sup>
Fault (safe) mode	Device has detected a fault condition	High Impedance	N/A

(1) I = Input, O = Output, I/O = Input/ Output , N/A = Not Available

#### 6.4.1.1 Active Mode

After power up, if the  $\overline{\text{SLEEP}}$  is pulled high, the TMAG6181-Q1 enters active mode where the SIN\_P, SIN\_N, COS\_P, and COS\_N outputs actively provide the angle of the applied magnetic field. In this mode, the turns counter is disabled and the TURNS pin does not provide the PWM output. The average current consumption during the active conversion is  $I_{\text{ACT}}$ .

#### 6.4.1.2 Active-Turns Mode

In this mode, the AMR sensor outputs are active and the turns counter is enabled. In this mode, the TURNS pin acts as a I/O and provides the counter information using the PWM output. In this mode, the Hall sensors are enabled and the outputs are monitored to update the turns counter. To enter this mode, the TURNS pin is pulled low for  $t > t_{\text{tc\_start}}$ . [Figure 6-15](#) shows the sequence to enter active-turns mode. After the TURNS pin is released, the falling edge of the first PWM pulse occurs after  $t_{\text{tc\_start}}$ . To exit this mode, the TURNS pin is pulled low for  $t > t_{\text{tc\_reset}}$  as defined in the [Specifications](#) section. After the turns counter is reset, the part goes back into active mode.

#### 6.4.1.3 Low-Power Mode

The TMAG6181-Q1 can enter into low-power mode after the turns counter is enabled. During this mode, the turns counter is active and the wake-up oscillator is used to wake the device at a regular interval,  $T_{\text{sleep}}$ . During this mode, the TURNS pin does not send out the PWM information and the input path is disabled. The average current consumption during this mode is denoted by  $I_{\text{LP}}$ .

[Figure 6-16](#) shows the sequence to enter and exit low-power mode from active-turns mode. To enter low-power mode, two consecutive pulses are provided on the  $\overline{\text{SLEEP}}$  pin. The pulses must be within the range of  $t_{\text{sleep\_pd}}$  as provided in the [Specifications](#) section. The timeout between these two consecutive pulses is defined by  $t_{\text{sleep\_timeout}}$  in the [Specifications](#) section. To exit low-power mode, the part monitors for a rising edge on the  $\overline{\text{SLEEP}}$  pin. This can be provided by driving the  $\overline{\text{SLEEP}}$  at a pulse width identical to the one used to enter low-power mode.

During low-power mode, an internal wake-up oscillator is used to wake the device up at regular intervals to monitor the states of the Hall sensors. During low-power mode, the rotation tracking feature is enabled to track rotations up to 8krpm at a very low power consumption. The period between two consecutive wake-up intervals is dependent on the frequency of the applied magnetic field (see [Rotation Tracking](#)).

#### 6.4.1.4 Sleep Mode

Sleep mode can place the device in the lowest current consumption state. When the voltage on  $\overline{\text{SLEEP}}$  pin goes below  $V_{\text{IL}}$  and stays low for longer than  $t_{\text{sleep\_mode}}$ , then the part enters sleep mode. The average current consumption during this mode is denoted by  $I_{\text{SLEEP}}$ , and this mode uses approximately ten times less current compared to low-power mode. The part exits sleep mode when the voltage on the  $\overline{\text{SLEEP}}$  pin goes above  $V_{\text{IH}}$ .

There is a 500k $\Omega$  pulldown resistor on the  $\overline{\text{SLEEP}}$  pin and, when the  $\overline{\text{SLEEP}}$  pin left floating, the part enters the sleep mode. TI recommends to ensure the  $\overline{\text{SLEEP}}$  pin is driven externally to a known logic state.

#### 6.4.1.5 Fault Mode

The TMAG6181-Q1 supports extensive fault diagnostics as detailed in [Diagnostics](#) section. When a fault is detected, the part enters fault mode. In this mode, the AMR outputs are placed in a high-impedance state.

## 7 Application and Implementation

---

### 注

Information in the following applications sections is not part of the TI component specification, and TI does not warrant its accuracy or completeness. TI's customers are responsible for determining suitability of components for their purposes, as well as validating and testing their design implementation to confirm system functionality.

---

### 7.1 Application Information

#### 7.1.1 Power Supply as the Reference for External ADC

The AMR output signals of the TMAG6181-Q1 are ratiometric to the supply voltage,  $V_{CC}$ . This enables the external ADC to use the TMAG6181-Q1 supply voltage as a reference and eliminate the errors that can arise if a separate reference voltage is used. This also enables to optimize the external ADC input range. TI therefore recommends to use the supply voltage ( $V_{CC}$ ) as the reference for the external ADCs. To ensure the noise on the power supply is minimized, TI recommends using a 0.1 $\mu$ F bypass capacitor.

#### 7.1.2 AMR Output Dependence on Airgap Distance

The AMR sensor is only sensitive to the direction of the applied magnetic field along the X-Y plane parallel to the chip surface. The applied magnetic field from a rotating magnet can vary based on the airgap distance between the TMAG6181-Q1 and the magnet.

As long the absolute field magnetic field is above the minimum field listed in *Recommended Operating Conditions*, the angle accuracy from the AMR outputs are independent of the value of the applied magnetic field.

### 7.1.3 Calibration of Sensor Errors

The TMAG6181-Q1 is factory-calibrated for the best angular accuracy. Some of the electrical errors from the sensor that impact the angle accuracy can be calibrated out for achieving the best performance. 7-1 shows the impact of the different sensor error parameters such as offset, amplitude mismatch and orthogonality error on the angle accuracy.

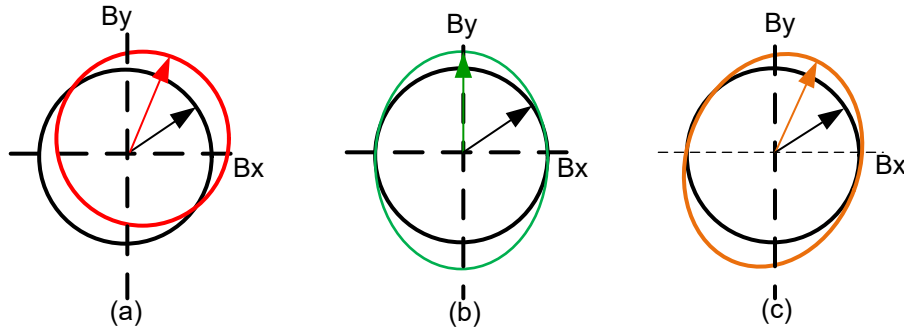

7-1. Angle Accuracy Impact Owing to Sensor Electrical Errors (a) Offset Error (b) Amplitude Mismatch Error (c) Orthogonality Error

Based on the parameters defined in *AMR Output Parameters*, the angle from the AMR sensors is given by 式 17:

$$\theta = \frac{\arctan2\left(\frac{A_{\sin} \sin(2\theta) + V_{\text{offset\_sin}}}{A_{\cos} \cos(2\theta) + V_{\text{offset\_cos}}}\right)}{2} \quad (17)$$

where

- $V_{\text{offset\_sin}}$  and  $V_{\text{offset\_cos}}$  are the differential offsets of the sine and cosine outputs
- $A_{\sin}$  and  $A_{\cos}$  are the differential amplitude of the sine and cosine outputs

The impact of the angle accuracy owing to the orthogonality error and the hysteresis errors is negligible for the TMAG6181-Q1 and can be ignored.

To calibrate the offset and amplitude mismatch errors, the magnetic field rotates over the entire range and the sine and cosine outputs are sampled continuously to obtain the minimum and maximum values of the outputs.

Users can calculate the average of the minimum and maximum values of the respective outputs across the full angle range to find the offset error of the sine and cosine outputs. Use 式 18 and 式 19 to calculate the offset correction parameters for sine and cosine.

$$V_{\text{os\_sin\_cal}} = \frac{V_{\sin(\text{max})} + V_{\sin(\text{min})}}{2} \quad (18)$$

$$V_{\text{os\_cos\_cal}} = \frac{V_{\cos(\text{max})} + V_{\cos(\text{min})}}{2} \quad (19)$$

Users can calculate the difference of the minimum and maximum values of the respective outputs across the full angle range to find the amplitude of the sine and cosine outputs. Use 式 20 to calculate the amplitude correction parameters for sine and cosine.

$$A_{\text{corr}} = 1 - \frac{V_{\sin(\text{max})} - V_{\sin(\text{min})}}{V_{\cos(\text{max})} - V_{\cos(\text{min})}} \quad (20)$$

## 7.2 Typical Application

The TMAG6181-Q1 AMR angle sensor can be used in either in single-ended output mode or differential output mode. TMAG6181-Q1 has the drive capability to either drive differential-ended or single-ended SAR or Sigma Delta ADCs. Typically, an external microcontroller processes the AMR output signals to extract the angular position.

The differential-ended output mode is helpful to eliminate any common mode disturbances in the system. [Figure 7-2](#) shows a typical application circuit where the differential output signals SIN\_P, SIN\_N, COS\_P, and COS\_N are all connected to the four single-ended ADCs in the external microcontroller. If differential ADCs are available, then they are typically recommended. The load capacitors and resistors must match each other to typically achieve high accuracy. During sleep mode or when a fault is detected, the outputs are placed in high-impedance state. To ensure that external microcontroller can detect this case, TI recommends using pulldown or pullup resistors.

The TMAG6181-Q1 can drive capacitive loads up to 10nF directly on the AMR output pins and, for a cable with capacitances of 100pF/m, the device can drive up to 100m capacitive loads. With the ability to source and sink currents up to 1mA, the device can drive resistive loads.

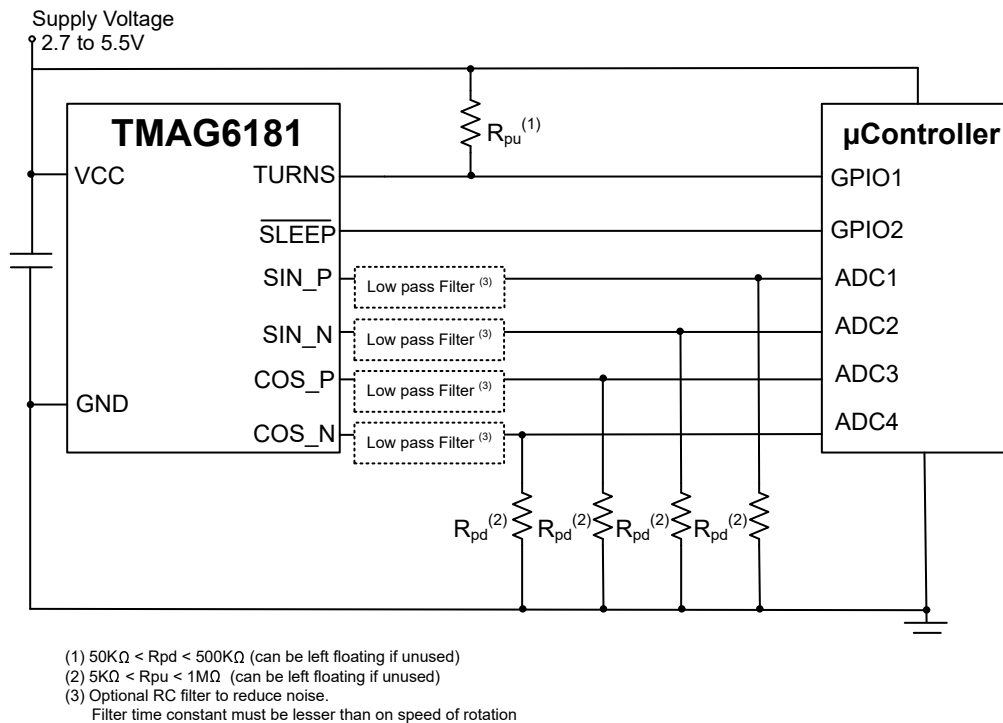

**Figure 7-2. Application Diagram for TMAG6181-Q1 in Differential-Ended Output Mode**

If the number of ADC ports in the microcontroller are limited, or if the number of wires from the sensor to the microcontroller must be kept to a minimum, [Figure 7-3](#) shows a typical application circuit where only the positive output channels (SIN\_P and COS\_P) are connected to single-ended ADCs. The unused output signals (SIN\_N and COS\_N) can be either left floating or connected to ground through a high resistance. In single-ended output mode, the dynamic range (SNR) and noise immunity is typically reduced compared to the differential output mode. To reduce noise on the outputs and for filtering EMC disturbances, an external low-pass filter such as a first order RC network can be used. The bandwidth of the external filter must be designed based on the rotation speed of the magnetic field to be detected. TI recommends adding pullup or pulldown resistors to ground on the single-ended outputs (SIN\_P and COS\_P) so the outputs are defined when the outputs are in high-impedance state. The supply voltage of the sensor is used as the reference for the ADCs in the microcontroller.



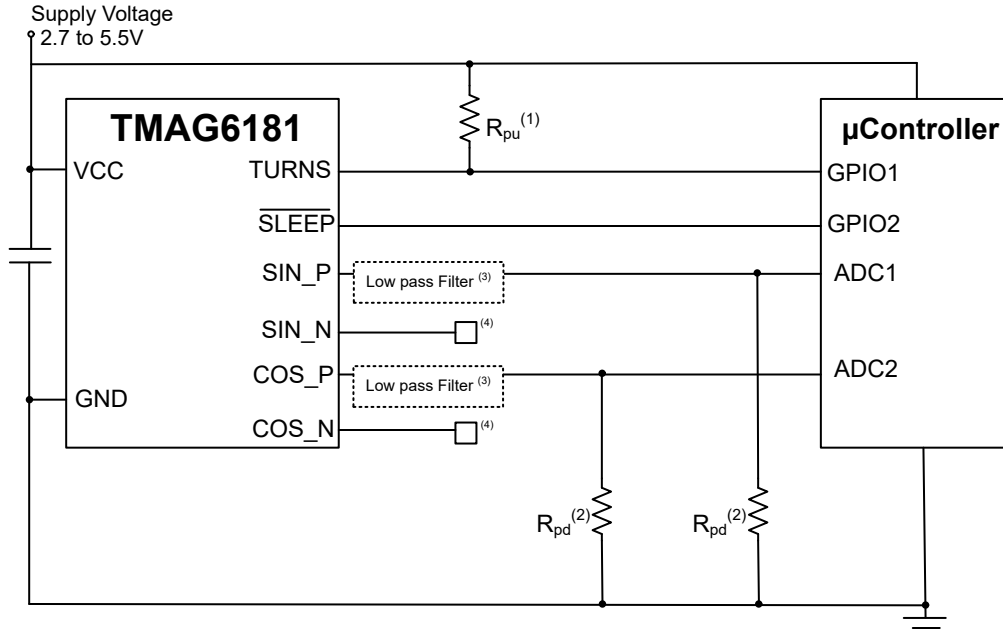

- (1)  $50\text{K}\Omega < R_{pu} < 500\text{K}\Omega$  (can be left floating if unused)
- (2)  $5\text{K}\Omega < R_{pd} < 1\text{M}\Omega$  (can be left floating if unused)
- (3) Optional RC filter to reduce noise.  
Filter time constant must be lesser than on speed of rotation
- (4) Can be left floating or connected to ground through  $R > 100\text{K}\Omega$

図 7-3. Application Diagram for TMAG6181-Q1 in Single-Ended Output Mode

### 7.2.1 Design Requirements

図 7-4 shows the center of the magnet aligned with the center of the sensor in a typical on-axis application.



図 7-4. On-Axis Measurement Setup for TMAG6181-Q1

Use the parameters listed in 表 7-1 for this design example.

表 7-1. Design Parameters

DESIGN PARAMETERS	ON-AXIS MEASUREMENT
$V_{CC}$	5V
Magnet	Cylinder: 4.7625mm diameter, 12.7mm thick, neodymium N52, Br = 1480
Output mode	Differential-ended
Maximum speed of the motor	8,000rpm
Desired angle error across temperature	<1°
Magnet to sensor placement	End of shaft

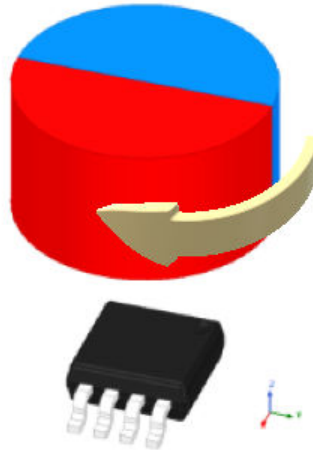
### 7.2.2 Detailed Design Procedure

For accurate angle measurement, the center of the magnet is aligned to the center of the sensor with acceptable tolerances. Follow these steps to ensure that the sensor is calibrated for best accuracy:

- Reference angle calibration - Set the reference angle based on the magnet alignment to the sensor. This error can be saved in the microcontroller for runtime absolute position calculation. This error is also known as angle offset in a system.
- Electrical offset calibration - See [Calibration of Sensor Errors](#) for the offset calibration procedure. If the sensor cannot be rotated across the full range, then the electrical offsets cannot be calibrated.
- Amplitude mismatch calibration - See [Calibration of Sensor Errors](#) for the amplitude mismatch calibration procedure. If the sensor cannot be rotated across the full range, then the amplitude mismatch cannot be calibrated.

#### 7.2.2.1 Designing with Multiple Sensors

Some applications have the need for multiple angle position sensors to either detect position in different parts of the system or for redundancy.

##### 7.2.2.1.1 Designing for Redundancy

For applications that require the highest level of functional safety, two angle sensors can be required for redundancy purposes.



図 7-5. Two Sensors Placed on Either Side of the Board for Redundancy

To achieve redundancy without any impact on the angle accuracy, the TMAG6181-Q1 devices can be placed on either side of the PCB as shown in 図 7-5. The AMR sensors are sensitive to only the direction of the magnetic field and independent on the value of the absolute magnetic field, therefore the magnetic accuracy is not compromised even if the devices are placed on the other side of the PCB.

### 7.2.2.1.2 Multiplexing Multiple Sensors

Some applications require multiple angle position sensors to detect position in different parts of the system. In those cases, the primary challenge would be the availability of multiple ADC that are required to digitize the information from the sensors. In cases where the sensor is placed remotely away from the microcontroller, there can be multiple output lines between the sensor and microcontroller.

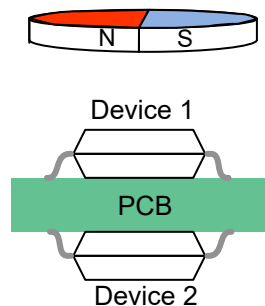
With the ability to place the output in high-impedance state during shutdown mode, multiple TMAG6181-Q1 devices can share the analog output. This can minimize the system cost by using a single ADC per channel. Figure 7-6 shows two devices that share the same analog output, with their respective SLEEP pins controlled by the microcontroller. A pull-down resistor can be used to pull the output to ground when both the devices are placed in shutdown mode.

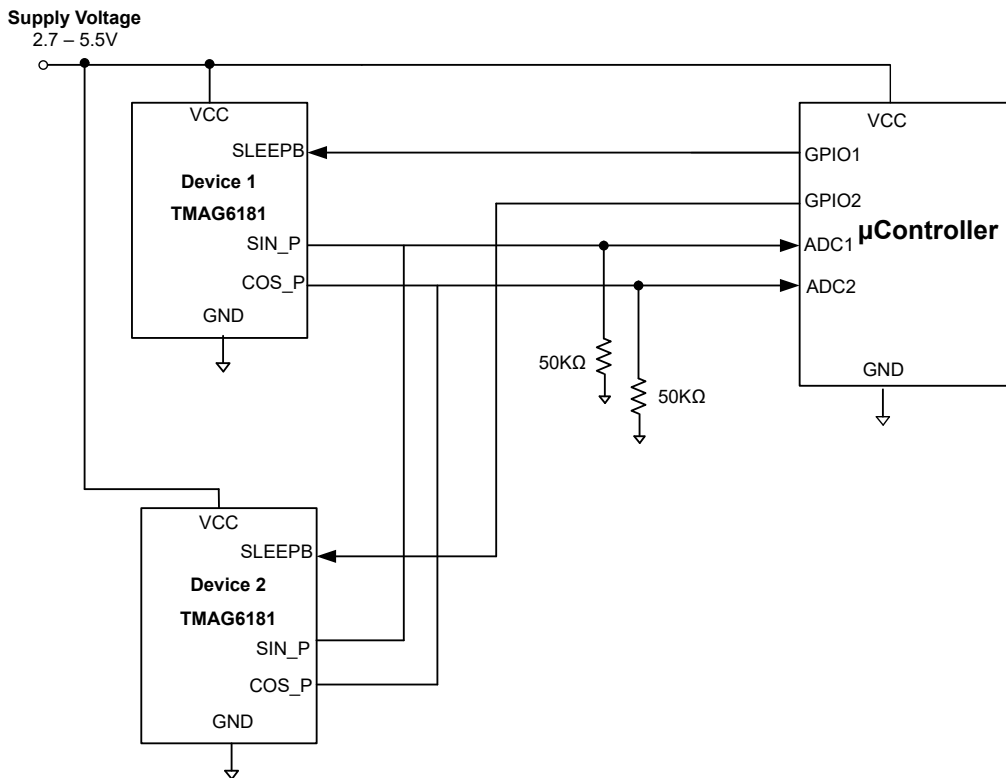

Figure 7-6. Multiple Sensors with Shared Output

Figure 7-7 shows how the GPIOs of the microcontroller can be used to multiplex the outputs from the two sensors. When the GPIO1 goes high, Device 1 is enabled and drives the output line to the corresponding output after the power-on time. During this time, GPIO2 is driven low and Device 2 is placed in shutdown mode. When the output from the second device must be measured, the first device must be turned off before the second device is enabled, indicated by  $t_{mux}$  in the timing diagram.  $B_1$  and  $B_2$  correspond to the magnetic fields seen by Device 1 and Device 2 respectively.

With the ability to support up to 10nF capacitive loads, the TMAG6181-Q1 can connect multiple sensors to the same output.



図 7-7. Timing Diagram for Multiplexing the Sensor Outputs

7.2.3 Application Curve

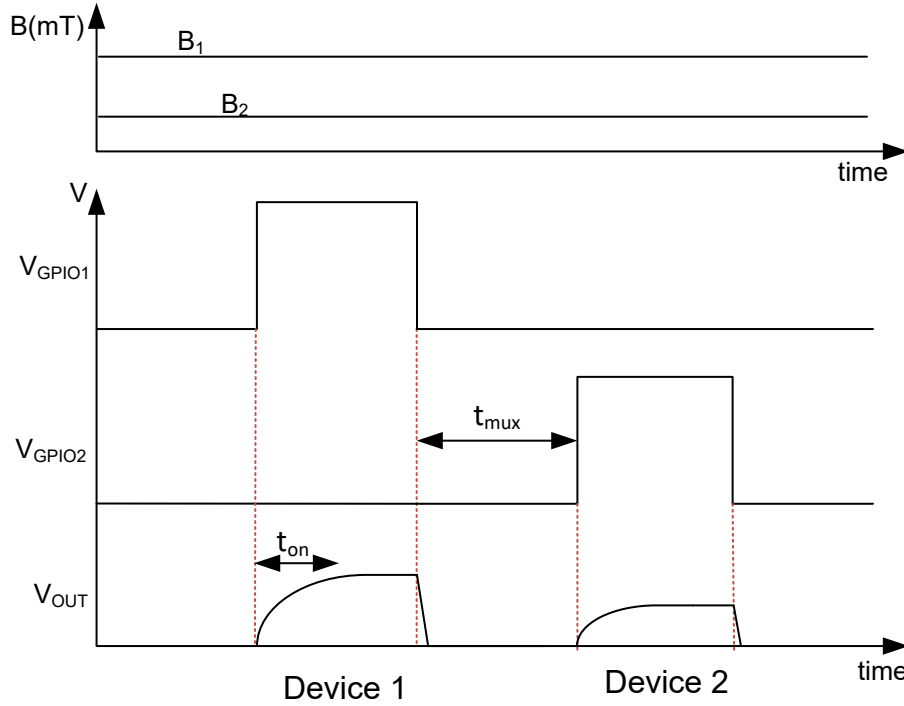

図 7-8. Angle Error with Dynamic Calibration

### 7.3 Power Supply Recommendations

A decoupling capacitor close to the device must be used to provide local energy with minimal inductance. TI recommends using a ceramic capacitor with a value of at least 0.01 $\mu$ F.

### 7.4 Layout

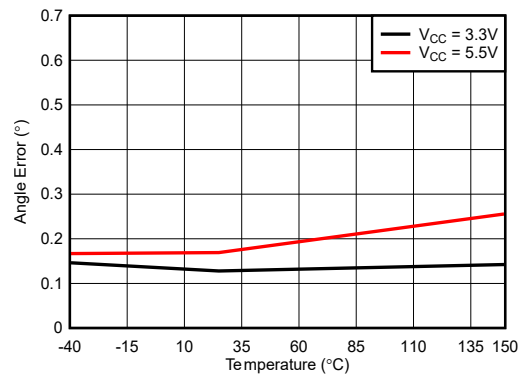
#### 7.4.1 Layout Guidelines

Magnetic fields pass through most nonferromagnetic materials with no significant disturbance. Embedding magnetic sensors within plastic or aluminum enclosures and sensing magnets on the outside is common practice. Magnetic fields also easily pass through most printed circuit boards (PCBs), which makes placing the magnet on the opposite side of the PCB possible.

#### 7.4.2 Layout Example



图 7-9. Layout Example With TMAG6181-Q1

## 8 Device and Documentation Support

### 8.1 ドキュメントの更新通知を受け取る方法

ドキュメントの更新についての通知を受け取るには、[www.tij.co.jp](http://www.tij.co.jp) のデバイス製品フォルダを開いてください。[通知] をクリックして登録すると、変更されたすべての製品情報に関するダイジェストを毎週受け取ることができます。変更の詳細については、改訂されたドキュメントに含まれている改訂履歴をご覧ください。

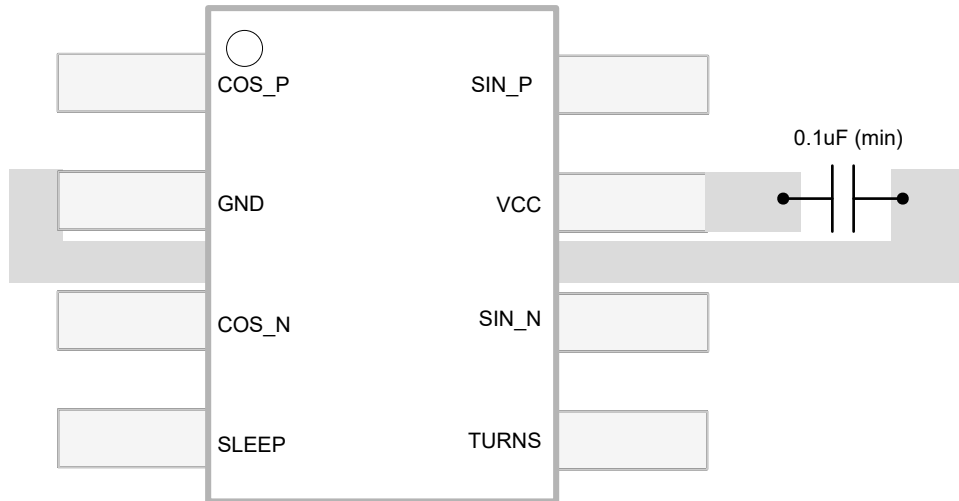
### 8.2 サポート・リソース

テキサス・インスツルメンツ E2E™ サポート・フォーラムは、エンジニアが検証済みの回答と設計に関するヒントをエキスパートから迅速かつ直接得ることができる場所です。既存の回答を検索したり、独自の質問をしたりすることで、設計に必要な支援を迅速に得ることができます。

リンクされているコンテンツは、各寄稿者により「現状のまま」提供されるものです。これらはテキサス・インスツルメンツの仕様を構成するものではなく、必ずしもテキサス・インスツルメンツの見解を反映したものではありません。テキサス・インスツルメンツの[使用条件](#)を参照してください。

### 8.3 Trademarks

テキサス・インスツルメンツ E2E™ is a trademark of Texas Instruments.

すべての商標は、それぞれの所有者に帰属します。

### 8.4 静電気放電に関する注意事項



この IC は、ESD によって破損する可能性があります。テキサス・インスツルメンツは、IC を取り扱う際には常に適切な注意を払うことを推奨します。正しい取り扱いおよび設置手順に従わない場合、デバイスを破損するおそれがあります。

ESD による破損は、わずかな性能低下からデバイスの完全な故障まで多岐にわたります。精密な IC の場合、パラメータがわずかに変化するだけで公表されている仕様から外れる可能性があるため、破損が発生しやすくなっています。

### 8.5 用語集

[テキサス・インスツルメンツ用語集](#) この用語集には、用語や略語の一覧および定義が記載されています。

## 9 Revision History

Changes from Revision A (February 2024) to Revision B (August 2024)	Page
• Added $V_{\text{offset\_room}}$ and $t_{\text{agc\_update}}$ table notes to the <i>Electrical Characteristics</i> table.....	5
• Removed $V_{\text{CC\_RAMP}}$ from the Electrical Characteristics table.....	5

Changes from Revision * (March 2023) to Revision A (February 2024)	Page
• データシートステータスを「事前情報」から「量産データ」へ変更.....	1

## 10 Mechanical, Packaging, and Orderable Information

The following pages include mechanical, packaging, and orderable information. This information is the most current data available for the designated devices. This data is subject to change without notice and revision of this document. For browser-based versions of this data sheet, refer to the left-hand navigation.

## 重要なお知らせと免責事項

テキサス・インスツルメンツは、技術データと信頼性データ (データシートを含みます)、設計リソース (リファレンス デザインを含みます)、アプリケーションや設計に関する各種アドバイス、Web ツール、安全性情報、その他のリソースを、欠陥が存在する可能性のある「現状のまま」提供しており、商品性および特定目的に対する適合性の黙示保証、第三者の知的財産権の非侵害保証を含むいかなる保証も、明示的または黙示的にかかわらず拒否します。

これらのリソースは、テキサス・インスツルメンツ製品を使用する設計の経験を積んだ開発者への提供を意図したものです。(1) お客様のアプリケーションに適した テキサス・インスツルメンツ製品の選定、(2) お客様のアプリケーションの設計、検証、試験、(3) お客様のアプリケーションに該当する各種規格や、その他のあらゆる安全性、セキュリティ、規制、または他の要件への確実な適合に関する責任を、お客様のみが単独で負うものとします。

上記の各種リソースは、予告なく変更される可能性があります。これらのリソースは、リソースで説明されている テキサス・インスツルメンツ製品を使用するアプリケーションの開発の目的でのみ、テキサス・インスツルメンツはその使用をお客様に許諾します。これらのリソースに関して、他の目的で複製することや掲載することは禁止されています。テキサス・インスツルメンツや第三者の知的財産権のライセンスが付与されている訳ではありません。お客様は、これらのリソースを自身で使用した結果発生するあらゆる申し立て、損害、費用、損失、責任について、テキサス・インスツルメンツおよびその代理人を完全に補償するものとし、テキサス・インスツルメンツは一切の責任を拒否します。

テキサス・インスツルメンツの製品は、[テキサス・インスツルメンツの販売条件](#)、または [ti.com](https://www.ti.com) やかかる テキサス・インスツルメンツ製品の関連資料などのいずれかを通じて提供する適用可能な条項の下で提供されています。テキサス・インスツルメンツがこれらのリソースを提供することは、適用されるテキサス・インスツルメンツの保証または他の保証の放棄の拡大や変更を意味するものではありません。

お客様がいかなる追加条項または代替条項を提案した場合でも、テキサス・インスツルメンツはそれらに異議を唱え、拒否します。

郵送先住所: Texas Instruments, Post Office Box 655303, Dallas, Texas 75265

Copyright © 2024, Texas Instruments Incorporated

**PACKAGING INFORMATION**

Orderable Device	Status (1)	Package Type	Package Drawing	Pins	Package Qty	Eco Plan (2)	Lead finish/ Ball material (6)	MSL Peak Temp (3)	Op Temp (°C)	Device Marking (4/5)	Samples
TMAG6181EDGKRQ1	ACTIVE	VSSOP	DGK	8	2500	RoHS & Green	SN	Level-1-260C-UNLIM	-40 to 150	6181	Samples

(1) The marketing status values are defined as follows:

**ACTIVE:** Product device recommended for new designs.

**LIFEBUY:** TI has announced that the device will be discontinued, and a lifetime-buy period is in effect.

**NRND:** Not recommended for new designs. Device is in production to support existing customers, but TI does not recommend using this part in a new design.

**PREVIEW:** Device has been announced but is not in production. Samples may or may not be available.

**OBSELETE:** TI has discontinued the production of the device.

(2) **RoHS:** TI defines "RoHS" to mean semiconductor products that are compliant with the current EU RoHS requirements for all 10 RoHS substances, including the requirement that RoHS substance do not exceed 0.1% by weight in homogeneous materials. Where designed to be soldered at high temperatures, "RoHS" products are suitable for use in specified lead-free processes. TI may reference these types of products as "Pb-Free".

**RoHS Exempt:** TI defines "RoHS Exempt" to mean products that contain lead but are compliant with EU RoHS pursuant to a specific EU RoHS exemption.

**Green:** TI defines "Green" to mean the content of Chlorine (Cl) and Bromine (Br) based flame retardants meet JS709B low halogen requirements of <=1000ppm threshold. Antimony trioxide based flame retardants must also meet the <=1000ppm threshold requirement.

(3) MSL, Peak Temp. - The Moisture Sensitivity Level rating according to the JEDEC industry standard classifications, and peak solder temperature.

(4) There may be additional marking, which relates to the logo, the lot trace code information, or the environmental category on the device.

(5) Multiple Device Markings will be inside parentheses. Only one Device Marking contained in parentheses and separated by a "-" will appear on a device. If a line is indented then it is a continuation of the previous line and the two combined represent the entire Device Marking for that device.

(6) Lead finish/Ball material - Orderable Devices may have multiple material finish options. Finish options are separated by a vertical ruled line. Lead finish/Ball material values may wrap to two lines if the finish value exceeds the maximum column width.

**Important Information and Disclaimer:**The information provided on this page represents TI's knowledge and belief as of the date that it is provided. TI bases its knowledge and belief on information provided by third parties, and makes no representation or warranty as to the accuracy of such information. Efforts are underway to better integrate information from third parties. TI has taken and continues to take reasonable steps to provide representative and accurate information but may not have conducted destructive testing or chemical analysis on incoming materials and chemicals. TI and TI suppliers consider certain information to be proprietary, and thus CAS numbers and other limited information may not be available for release.

In no event shall TI's liability arising out of such information exceed the total purchase price of the TI part(s) at issue in this document sold by TI to Customer on an annual basis.



**TAPE AND REEL INFORMATION**

**QUADRANT ASSIGNMENTS FOR PIN 1 ORIENTATION IN TAPE**

\*All dimensions are nominal

Device	Package Type	Package Drawing	Pins	SPQ	Reel Diameter (mm)	Reel Width W1 (mm)	A0 (mm)	B0 (mm)	K0 (mm)	P1 (mm)	W (mm)	Pin1 Quadrant
TMAG6181EDGKRQ1	VSSOP	DGK	8	2500	330.0	12.4	5.3	3.4	1.4	8.0	12.0	Q1

**TAPE AND REEL BOX DIMENSIONS**

\*All dimensions are nominal

Device	Package Type	Package Drawing	Pins	SPQ	Length (mm)	Width (mm)	Height (mm)
TMAG6181EDGKRQ1	VSSOP	DGK	8	2500	366.0	364.0	50.0

# DGK0008A



# PACKAGE OUTLINE

VSSOP - 1.1 mm max height

SMALL OUTLINE PACKAGE



4214862/A 04/2023

**NOTES:**

PowerPAD is a trademark of Texas Instruments.

1. All linear dimensions are in millimeters. Any dimensions in parenthesis are for reference only. Dimensioning and tolerancing per ASME Y14.5M.
2. This drawing is subject to change without notice.
3. This dimension does not include mold flash, protrusions, or gate burrs. Mold flash, protrusions, or gate burrs shall not exceed 0.15 mm per side.
4. This dimension does not include interlead flash. Interlead flash shall not exceed 0.25 mm per side.
5. Reference JEDEC registration MO-187.

# EXAMPLE BOARD LAYOUT

DGK0008A

™ VSSOP - 1.1 mm max height

SMALL OUTLINE PACKAGE



LAND PATTERN EXAMPLE  
EXPOSED METAL SHOWN  
SCALE: 15X



SOLDER MASK DETAILS

4214862/A 04/2023

NOTES: (continued)

6. Publication IPC-7351 may have alternate designs.
7. Solder mask tolerances between and around signal pads can vary based on board fabrication site.
8. Vias are optional depending on application, refer to device data sheet. If any vias are implemented, refer to their locations shown on this view. It is recommended that vias under paste be filled, plugged or tented.
9. Size of metal pad may vary due to creepage requirement.

# EXAMPLE STENCIL DESIGN

DGK0008A

<sup>TM</sup> VSSOP - 1.1 mm max height

SMALL OUTLINE PACKAGE



SOLDER PASTE EXAMPLE  
SCALE: 15X

4214862/A 04/2023

NOTES: (continued)

11. Laser cutting apertures with trapezoidal walls and rounded corners may offer better paste release. IPC-7525 may have alternate design recommendations.
12. Board assembly site may have different recommendations for stencil design.

## 重要なお知らせと免責事項

TI は、技術データと信頼性データ (データシートを含みます)、設計リソース (リファレンス・デザインを含みます)、アプリケーションや設計に関する各種アドバイス、Web ツール、安全性情報、その他のリソースを、欠陥が存在する可能性のある「現状のまま」提供しており、商品性および特定目的に対する適合性の黙示保証、第三者の知的財産権の非侵害保証を含むいかなる保証も、明示的または黙示的にかかわらず拒否します。

これらのリソースは、TI 製品を使用する設計の経験を積んだ開発者への提供を意図したものです。(1) お客様のアプリケーションに適した TI 製品の選定、(2) お客様のアプリケーションの設計、検証、試験、(3) お客様のアプリケーションに該当する各種規格や、その他のあらゆる安全性、セキュリティ、規制、または他の要件への確実な適合に関する責任を、お客様のみが単独で負うものとし、

上記の各種リソースは、予告なく変更される可能性があります。これらのリソースは、リソースで説明されている TI 製品を使用するアプリケーションの開発の目的でのみ、TI はその使用をお客様に許諾します。これらのリソースに関して、他の目的で複製することや掲載することは禁止されています。TI や第三者の知的財産権のライセンスが付与されている訳ではありません。お客様は、これらのリソースを自身で使用した結果発生するあらゆる申し立て、損害、費用、損失、責任について、TI およびその代理人を完全に補償するものとし、TI は一切の責任を拒否します。

TI の製品は、[TI の販売条件](#)、または [ti.com](#) やかかる TI 製品の関連資料などのいずれかを通じて提供する適用可能な条項の下で提供されています。TI がこれらのリソースを提供することは、適用される TI の保証または他の保証の放棄の拡大や変更を意味するものではありません。

お客様がいかなる追加条項または代替条項を提案した場合でも、TI はそれらに異議を唱え、拒否します。

郵送先住所 : Texas Instruments, Post Office Box 655303, Dallas, Texas 75265  
Copyright © 2024, Texas Instruments Incorporated