

TMP23x 低消費電力、高精度アナログ出力温度センサ

1 特長

- サーマスタに対するコスト効率の優れた代替
- 広い温度範囲にわたって厳密な精度を維持
 - $\pm 2.5^{\circ}\text{C}$ (最大値): $-40^{\circ}\text{C} \sim +150^{\circ}\text{C}$ (TMP235)
 - $\pm 2.5^{\circ}\text{C}$ (最大値): $-10^{\circ}\text{C} \sim +125^{\circ}\text{C}$ (TMP236)
- 2つの精度レベルで供給
 - A2 レベル: $\pm 0.5^{\circ}\text{C}$ (標準値)
 - A4 レベル: $\pm 1^{\circ}\text{C}$ (標準値)
- 正の勾配のセンサ・ゲイン、オフセット (標準値)
 - $10\text{mV}/^{\circ}\text{C}$, 0°C で 500mV (TMP235)
 - $19.5\text{mV}/^{\circ}\text{C}$, 0°C で 400mV (TMP236)
- 広い動作電源電圧範囲
 - $2.3\text{V} \sim 5.5\text{V}$ (TMP235)
 - $3.1\text{V} \sim 5.5\text{V}$ (TMP236)
- 出力の短絡保護
- 低消費電力: $9\mu\text{A}$ (標準値)
- 最大 1000pF の負荷を駆動できる強力な出力
- 供給されるパッケージ・オプション
 - 5ピンの SC70 (DCK) 表面実装
 - 3ピンの SOT-23 (DBZ) 表面実装
 - 業界標準の LMT8x-Q1 および LM20 温度センサとフットプリント互換

2 アプリケーション

- グリッド・インフラ
- ワイヤレスおよびテレコム・インフラ
- 車載用インフォテインメント
- ファクトリ・オートメーションとファクトリ制御
- 試験 / 測定機器

3 概要

TMP23x デバイスは、温度に比例する出力電圧を備えた高精度 CMOS IC リニア・アナログ温度センサのファミリーであり、多様なアナログ温度センシング・アプリケーションで使用できます。これらの温度センサは、市販の類似のピン互換デバイスよりも高精度であり、 $0^{\circ}\text{C} \sim +70^{\circ}\text{C}$ の範囲で $\pm 0.5^{\circ}\text{C}$ (標準値) の精度を持っています。本シリーズの高い精度は、多くのアナログ温度センシング・アプリケーション向けに設計されたものです。TMP235 デバイスは、 $-40^{\circ}\text{C} \sim +150^{\circ}\text{C}$ の温度範囲と、 $2.3\text{V} \sim 5.5\text{V}$ の電源電圧範囲の全体にわたって、 $10\text{mV}/^{\circ}\text{C}$ の正の出力勾配を提供します。より高ゲインの TMP236 センサは、 $-10^{\circ}\text{C} \sim +125^{\circ}\text{C}$ と、 $3.1\text{V} \sim 5.5\text{V}$ の電源電圧範囲について、 $19.5\text{mV}/^{\circ}\text{C}$ の正の出力勾配を提供します。

標準静止電流は $9\mu\text{A}$ 、標準の電源オン時間は $800\mu\text{s}$ で、効果的な電源サイクリング・アーキテクチャにより、バッテリー駆動のデバイスで消費電力を最小化できます。Class-AB 出力ドライバは最大出力が $500\mu\text{A}$ と強力で、最大 1000pF の容量性負荷を駆動でき、アナログ/デジタル・コンバータのサンプルおよびホールド入力と直接接続するよう設計されています。優れた精度と強力なリニア出力ドライバを備えた TMP23x アナログ出力温度センサは、パッシブなサーミスタに代わるコスト効率の優れた代替品となります。

製品情報⁽¹⁾

型番	パッケージ	本体サイズ (公称)
TMP235、 TMP236	SC70 (5)	2.00mmx1.25mm
	SOT-23 (3)	2.92mmx1.30mm

(1) 利用可能なすべてのパッケージについては、このデータシートの末尾にある注文情報を参照してください。

機能ブロック図

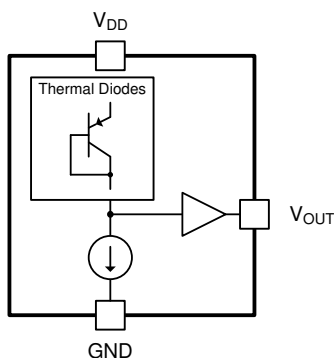

出力電圧と周囲温度との関係

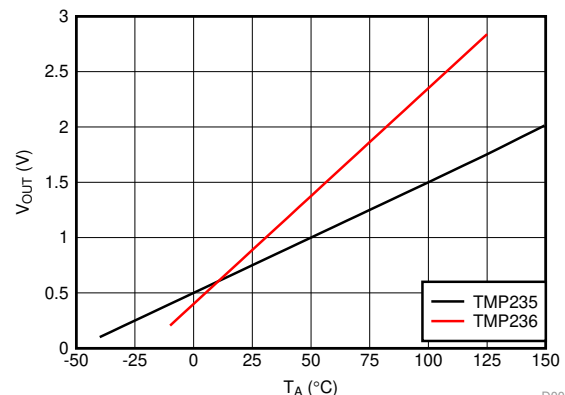

D003

目次

1	特長	1	7.4	Device Functional Modes	10
2	アプリケーション	1	8	Application and Implementation	11
3	概要	1	8.1	Application Information	11
4	改訂履歴	2	8.2	Typical Application	11
5	Pin Configuration and Functions	3	9	Power Supply Recommendations	12
6	Specifications	4	10	Layout	12
6.1	Absolute Maximum Ratings	4	10.1	Layout Guidelines	12
6.2	ESD Ratings	4	10.2	Layout Examples	12
6.3	Recommended Operating Conditions	4	11	デバイスおよびドキュメントのサポート	13
6.4	Thermal Information	4	11.1	関連リンク	13
6.5	Electrical Characteristics	5	11.2	ドキュメントの更新通知を受け取る方法	13
6.6	Typical Characteristics	6	11.3	コミュニティ・リソース	13
7	Detailed Description	8	11.4	商標	13
7.1	Overview	8	11.5	静電気放電に関する注意事項	13
7.2	Functional Block Diagram	8	11.6	Glossary	13
7.3	Feature Description	8	12	メカニカル、パッケージ、および注文情報	13

4 改訂履歴

資料番号末尾の英字は改訂を表しています。その改訂履歴は英語版に準じています。

Revision D (August 2018) から Revision E に変更	Page
• Changed recommended operating temperature range from: -50°C to 150°C to: -40°C to 150°C	4
• Changed power supply bypassing recommendations on how to avoid noise effect on the device output	12

Revision C (August 2018) から Revision D に変更	Page
• DBZ (SOT-23)パッケージのステータスをプレビュー版から量産データに変更	1

Revision B (February 2018) から Revision C に変更	Page
• DBZ (SOT-23)プレビュー版パッケージを追加	1
• Added TMP236 test conditions to the operating current parameters	5
• Added SOT-23 and SC70 package test conditions to the Accuracy Level 2 (A2) limits in the 0°C to 70°C range	5

Revision A (December 2017) から Revision B に変更	Page
• 標準精度仕様への言及を、「 $\pm 1^{\circ}\text{C}$ および $\pm 2^{\circ}\text{C}$ 」から「 $\pm 0.5^{\circ}\text{C}$ および $\pm 1^{\circ}\text{C}$ 」へ変更	1
• Deleted erroneous AOQL footnote	5
• Changed specification limits indicated in 図 1	6
• Added <i>Device Functional Modes</i> section	10

2017年9月発行のものから更新	Page
• ドキュメントのステータスを「事前情報」から「量産データ」に変更	1

5 Pin Configuration and Functions

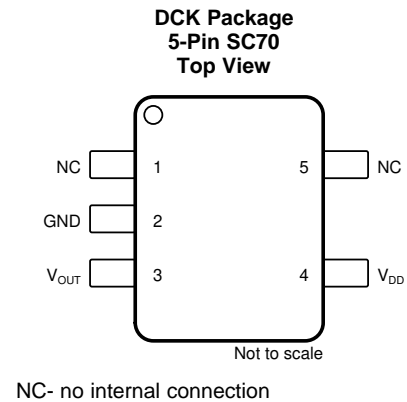
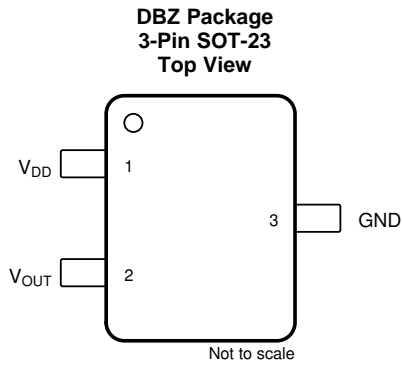

Pin Functions

NAME	PIN		TYPE	DESCRIPTION
	SOT-23	SC70		
GND	3	2	Ground	Power supply ground.
NC	—	5	—	No internal connection. This pin may be left floating or connected to GND.
NC	—	1	—	No internal connection. This pin may be left floating or connected to GND.
V _{OUT}	2	3	O	Outputs voltage proportional to temperature
V _{DD}	1	4	I	Positive supply input

6 Specifications

6.1 Absolute Maximum Ratings

over operating free-air temperature range (unless otherwise noted) ⁽¹⁾

	MIN	MAX	UNIT
Supply voltage, V_{DD}		+6	V
Output voltage, V_{OUT}	-0.3	($V_{DD} + 0.3$)	
Output current	-30	+30	mA
Latch-up current, each pin	-200	+200	
Junction temperature (T_J)		+150	°C
Storage temperature (T_{stg})	-65	+150	

- (1) Stresses beyond those listed under *Absolute Maximum Ratings* may cause permanent damage to the device. These stress ratings only, which do not imply functional operation of the device at these or any other conditions beyond those indicated under *Recommended Operating Conditions*. Exposure to absolute-maximum-rated conditions for extended periods may affect device reliability.

6.2 ESD Ratings

			VALUE	UNIT
$V_{(ESD)}$	Electrostatic discharge	Human-body model (HBM) per JESD22-A114 ⁽¹⁾	±4000	V
		Charged-device model (CDM), per JEDEC specification JESD22-C101 ⁽²⁾	±1000	

- (1) JEDEC document JEP155 states that 500-V HBM allows safe manufacturing with a standard ESD control process.
 (2) JEDEC document JEP157 states that 250-V CDM allows safe manufacturing with a standard ESD control process.

6.3 Recommended Operating Conditions

over operating free-air temperature range (unless otherwise noted)

		MIN	NOM	MAX	UNIT
V_{DD}	Input voltage (TMP235)	2.3		5.5	V
	Input voltage (TMP236)	3.1		5.5	
T_A	Operating free-air temperature	-40		150	°C

6.4 Thermal Information

THERMAL METRIC ⁽¹⁾⁽²⁾		TMP235		UNIT
		DCK (SC70)	DBZ (SOT-23)	
		PINS	PINS	
$R_{\theta JA}$	Junction-to-ambient thermal resistance ⁽³⁾⁽⁴⁾	275	167	°C/W
$R_{\theta JC(top)}$	Junction-to-case (top) thermal resistance	84	90	°C/W
$R_{\theta JB}$	Junction-to-board thermal resistance	56	146	°C/W
Ψ_{JT}	Junction-to-top characterization parameter	1.2	35	°C/W
Ψ_{JB}	Junction-to-board characterization parameter	55	146	°C/W

- (1) For more information about traditional and new thermal metrics, see the [Semiconductor and IC Package Thermal Metrics](#) application report.
 (2) For information on self-heating and thermal response time see [Layout Guidelines](#) section.
 (3) The junction to ambient thermal resistance ($R_{\theta JA}$) under natural convection is obtained in a simulation on a JEDEC-standard, High-K board as specified in JESD51-7, in an environment described in JESD51-2. Exposed pad packages assume that thermal vias are included in the PCB, per JESD 51-5.
 (4) Changes in output due to self heating can be computed by multiplying the internal dissipation by the thermal resistance.

6.5 Electrical Characteristics

TMP235: $V_{DD} = 2.3\text{ V to }5.5\text{ V}$, GND = Ground, $T_A = -40^\circ\text{C to }+125^\circ\text{C}$ and no load (unless otherwise noted)

TMP236: $V_{DD} = 3.1\text{ V to }5.5\text{ V}$, GND = Ground, $T_A = -10^\circ\text{C to }+125^\circ\text{C}$ and no load (unless otherwise noted)

PARAMETER		TEST CONDITIONS		MIN	TYP	MAX	UNIT
POWER SUPPLY							
I_{DD}	Operating current	$T_A = 25^\circ\text{C}$, $V_{DD} = 2.3\text{ V}$, TMP235				9	μA
		$T_A = 25^\circ\text{C}$, $V_{DD} = 3.1\text{ V}$, TMP236				10	
		$T_A = -40^\circ\text{C to }+125^\circ\text{C}$, TMP235				14.5	
		$T_A = -10^\circ\text{C to }+125^\circ\text{C}$, TMP236				15	
		$T_A = 150^\circ\text{C}$, TMP235				17	
$\Delta^\circ\text{C}/\Delta V_{DD}$	Line regulation			-0.1	0.02	0.1	$^\circ\text{C}/\text{V}$
SENSOR ACCURACY							
T_{ACY}	Temperature accuracy ⁽¹⁾		$T_A = 25^\circ\text{C}$			± 0.5	$^\circ\text{C}$
			$T_A = 0^\circ\text{C to }70^\circ\text{C}$ (SC70 Package)	-1	± 0.5	+1	
			$T_A = 0^\circ\text{C to }70^\circ\text{C}$ (SOT-23 Package)	-1.2	± 0.5	+1.2	
			$T_A = -40^\circ\text{C to }+125^\circ\text{C}$ (TMP235A2)	-2	± 0.5	+2	
			$T_A = -10^\circ\text{C to }+125^\circ\text{C}$ (TMP236A2)	-2	± 0.5	+2	
			$T_A = -40^\circ\text{C to }+150^\circ\text{C}$ (TMP235A2)	-2	± 0.5	+2	
		Accuracy Level 4 (A4)	$T_A = 25^\circ\text{C}$			± 1	
			$T_A = 0^\circ\text{C to }70^\circ\text{C}$	-2	± 1	+2	
			$T_A = -40^\circ\text{C to }+125^\circ\text{C}$ (TMP235A4)	-4	± 1	+4	
			$T_A = -10^\circ\text{C to }+125^\circ\text{C}$ (TMP236A4)	-4	± 1	+4	
$T_A = -40^\circ\text{C to }+150^\circ\text{C}$ (TMP235A4)	-5	± 1	+5				
SENSOR OUTPUT							
$V_{0^\circ\text{C}}$	Output voltage offset at 0°C	TMP235				500	mV
		TMP236				400	
T_C	Temperature coefficient (sensor gain)	TMP235				10	$\text{mV}/^\circ\text{C}$
		TMP236				19.5	
V_{ONL}	Output nonlinearity ⁽¹⁾	$T_A = 0^\circ\text{C to }70^\circ\text{C}$, no load				± 0.5	$^\circ\text{C}$
I_{OUT}	Output current					500	μA
Z_{OUT}	Output impedance	$I_{OUT} = 100\ \mu\text{A}$, $f = 100\ \text{Hz}$				20	Ω
		$I_{OUT} = 100\ \mu\text{A}$, $f = 500\ \text{Hz}$				50	
	Output load regulation	$T_A = 0^\circ\text{C to }70^\circ\text{C}$, $I_{OUT} = 100\ \mu\text{A}$, $\Delta V_{OUT} / \Delta I_{OUT}$				1	Ω
t_{ON}	Turn on time	Time to reach accuracy within $\pm 0.5^\circ\text{C}$				800	μs
C_{LOAD}	Typical load capacitance					1000	pF
t_{RES}	Thermal response to 63%	SC70	30°C (Air) to $+125^\circ\text{C}$ (Fluid Bath)			1.3	s

- (1) Accuracy is defined as the error between the measured and reference output voltages, tabulated in the [TMP235 Transfer Table](#) and [TMP236 Transfer Table](#) at the specified conditions of supply voltage and temperature (expressed in $^\circ\text{C}$). Accuracy limits include line regulation within the specified conditions. Accuracy limits do not include load regulation; they assume no DC load.

6.6 Typical Characteristics

at $T_A = 25^\circ\text{C}$, (unless otherwise noted)

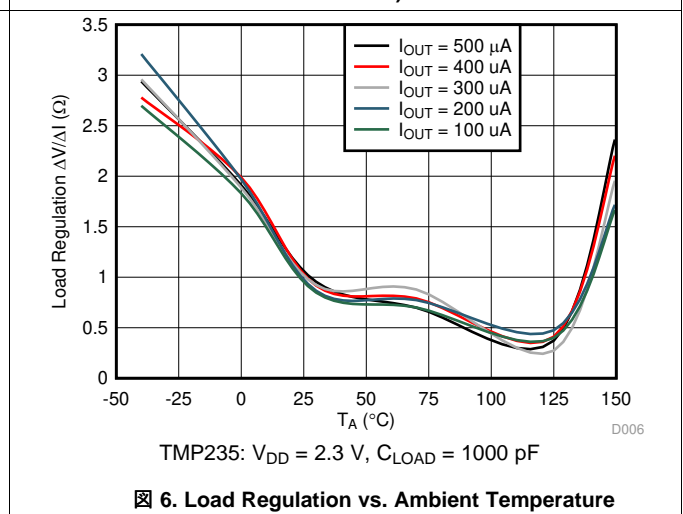
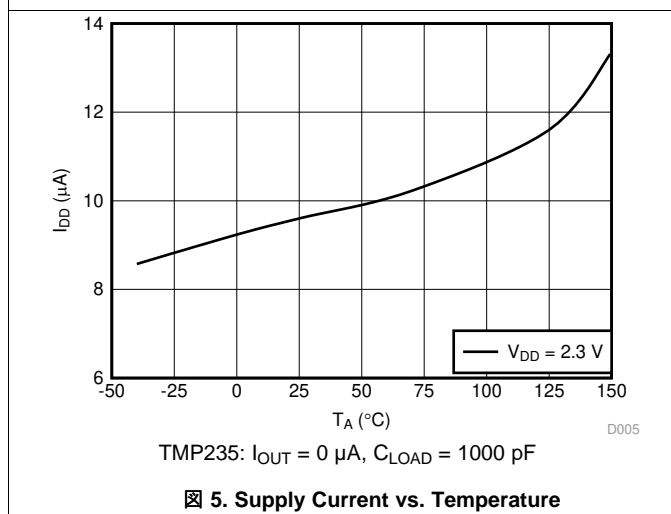
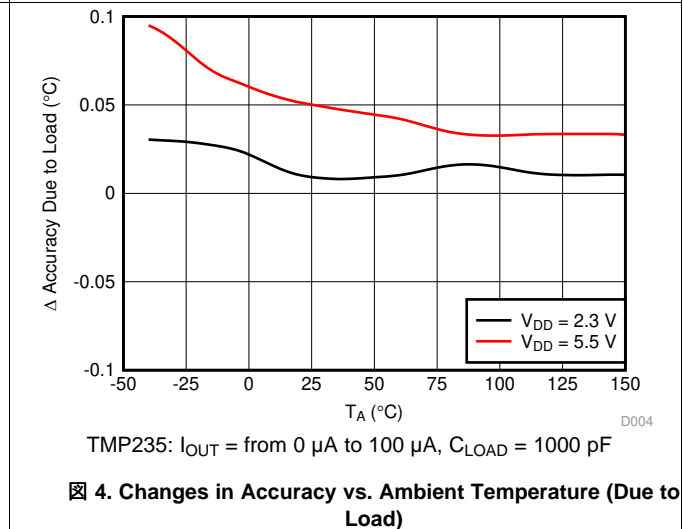
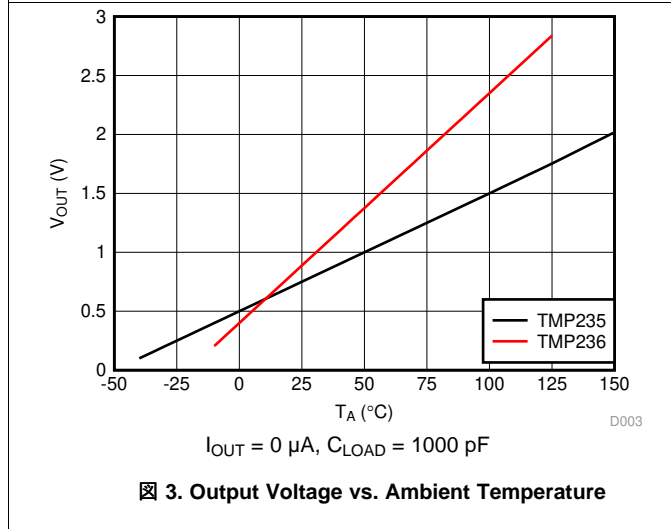
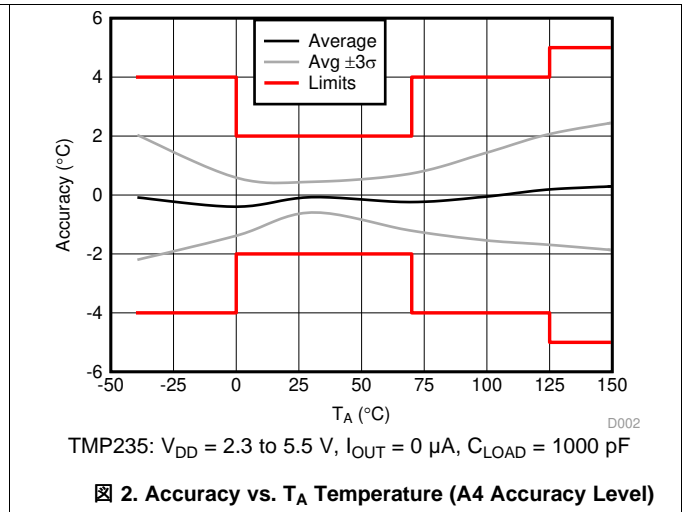
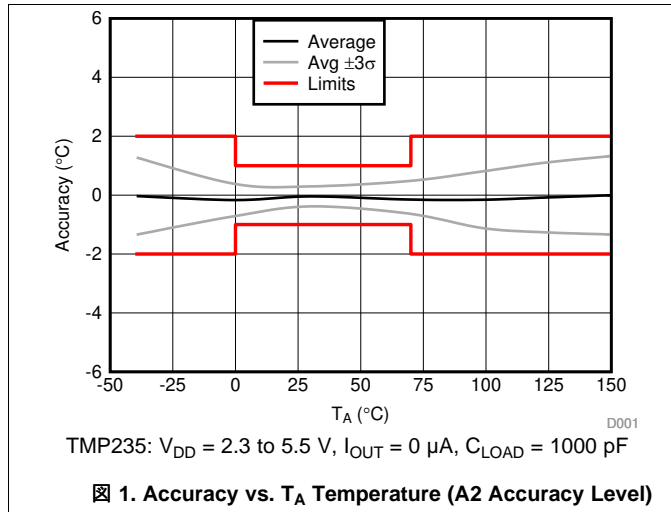

Typical Characteristics (continued)

at $T_A = 25^\circ\text{C}$, (unless otherwise noted)

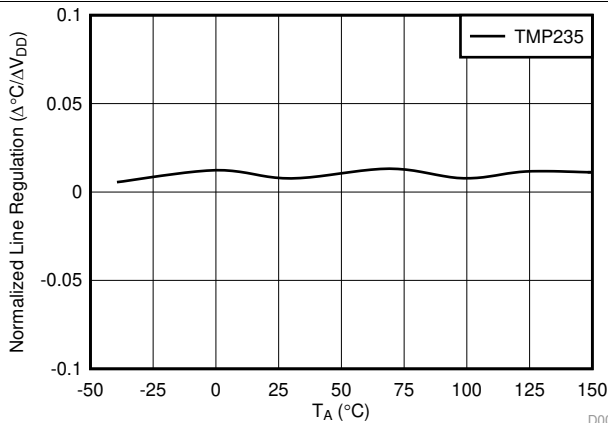

TMP235: $V_{DD} = 2.3$ to 5.5 V, $I_{OUT} = 0$ μA , $C_{LOAD} = 1000$ pF

Figure 7. Line Regulation ($\Delta^\circ\text{C} / \Delta V_{DD}$) vs. Ambient Temperature

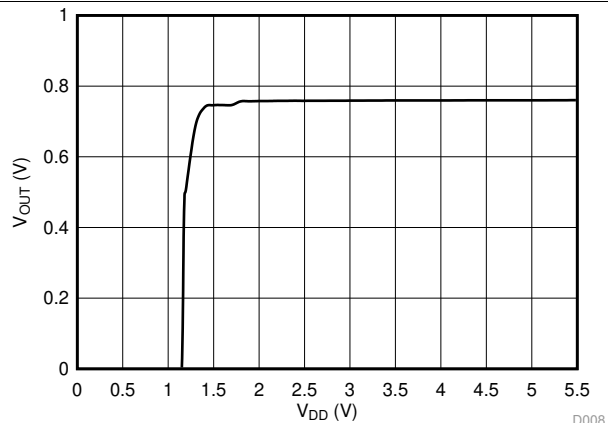

TMP235: $T_A = 25^\circ\text{C}$

Figure 8. Output Voltage vs. Power Supply

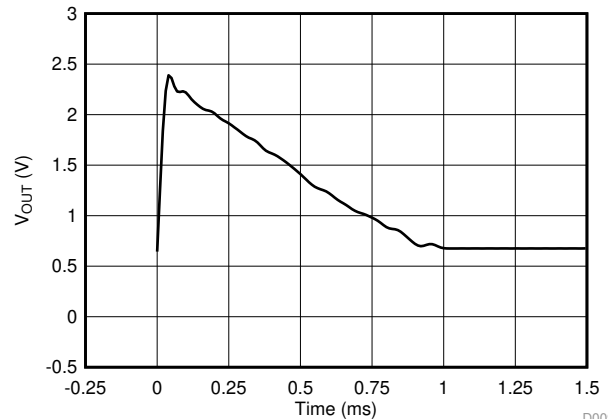

TMP235: $T_A = 25^\circ\text{C}$

Figure 9. Output vs. Settling Time to Step V_{DD}

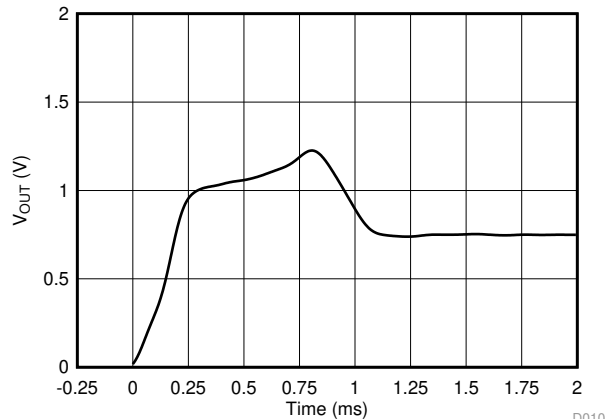

TMP235: $T_A = 25^\circ\text{C}$, V_{DD} Ramp Rate = 5 V/ms

Figure 10. Output vs. Settling Time to Ramp V_{DD}

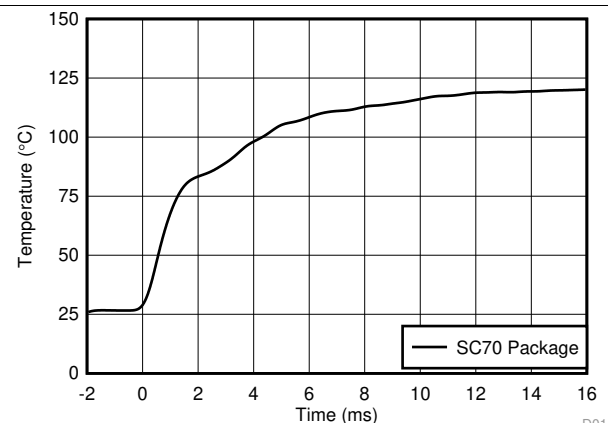

TMP235: 1×1 (inches) PCB, Air 26°C to Fluid Bath 123°C

Figure 11. Thermal Response (Air-to-Fluid Bath)

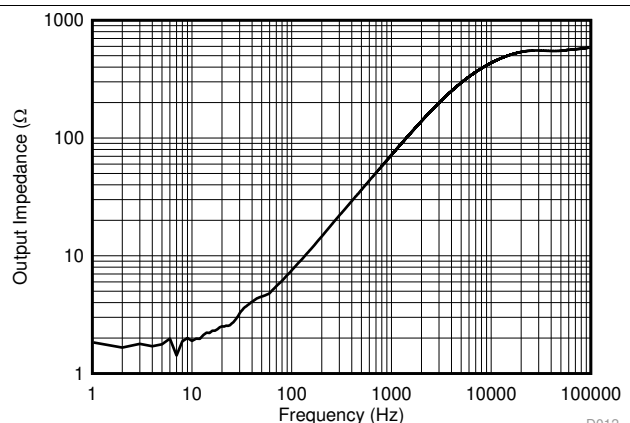

TMP235: $T_A = 25^\circ\text{C}$, $V_{DD} = 5$ V, $I_{OUT} = 100$ μA

Figure 12. Output Impedance vs. Frequency

7 Detailed Description

7.1 Overview

The TMP23x devices are a family of linear analog temperature sensors with an output voltage proportional to temperature. These temperature sensors have an accuracy from 0°C to 70°C of ±1.25°C (TMP23xA2) and ±2°C (TMP23xA4). The TMP235 device provides a positive slope output of 10 mV/°C over the full –40°C to +150°C temperature range and a supply range from 2.3 V to 5.5 V. The higher gain TMP236 sensor provides a positive slope output of 19.5 mV/°C from –10°C to +125°C and a supply range from 3.1 V to 5.5 V. A class-AB output driver provides a maximum output of 500 µA to drive capacitive loads up to 1000 pF.

7.2 Functional Block Diagram

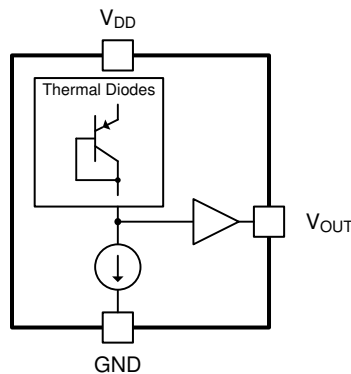

7.3 Feature Description

As shown in [Figure 3](#), the TMP23x devices are linear. A small V_{OUT} gain shift, however, is present at temperatures above 100°C. When small shifts are expected, a piecewise linear function provides the best accuracy and is used for the device accuracy specifications (see [Specifications](#)). Typical output voltages of the TMP23x devices across the full operating temperature range are listed in [Table 3](#) and [Table 4](#). The ideal linear columns represent the ideal linear V_{OUT} output response with respect to temperature, while the piecewise linear columns indicate the small voltage shift at elevated temperatures.

The piecewise linear function uses three temperature ranges listed in [Table 1](#) and [Table 2](#). In equation form, the voltage output V_{OUT} of the TMP23x is calculated by [Equation 1](#):

$$V_{OUT} = (T_A - T_{INFL}) \times T_C + V_{OFFS}$$

where

- V_{OUT} is the TMP23x voltage output for a given temperature
 - T_A is the ambient temperature in °C
 - T_{INFL} is the temperature inflection point for a piecewise segment in °C
 - T_C is the TMP23x temperature coefficient or gain
 - V_{OFFS} is the TMP23x voltage offset
- (1)

Therefore, the T_A temperature for a given V_{OUT} voltage output within a piecewise voltage range (V_{RANGE}) is calculated in [Equation 2](#). For applications where the accuracy enhancement above 100°C is not required, use the first row of [Table 1](#) and [Table 2](#) for all voltages.

$$T_A = (V_{OUT} - V_{OFFS}) / T_C + T_{INFL}$$

(2)

表 1. TMP235 Piecewise Linear Function Summary

T_A RANGE (°C)	V_{RANGE} (mV)	T_{INFL} (°C)	T_C (mV/°C)	V_{OFFS} (mV)
–40 to +100	< 1500	0	10	500
100 to 125	1500 to 1752.5	100	10.1	1500
125 to 150	> 1752.5	125	10.6	1752.5

表 2. TMP236 Piecewise Linear Function Summary

T_A RANGE (°C)	V_{RANGE} (mV)	T_{INFL} (°C)	T_C (mV/°C)	V_{OFFS} (mV)
-40 to +100	≤ 2350	0	19.5	400
100 to 125	> 2350	100	19.7	2350
125 to 150	—	—	—	—

表 3. TMP235 Transfer Table

TEMPERATURE (°C)	V_{OUT} (mV) IDEAL LINEAR VALUES	V_{OUT} (mV) PIECEWISE LINEAR VALUES
-40	100	100
-35	150	150
-30	200	200
-25	250	250
-20	300	300
-15	350	350
-10	400	400
-5	450	450
0	500	500
5	550	550
10	600	600
15	650	650
20	700	700
25	750	750
30	800	800
35	850	850
40	900	900
45	950	950
50	1000	1000
55	1050	1050
60	1100	1100
65	1150	1150
70	1200	1200
75	1250	1250
80	1300	1300
85	1350	1350
90	1400	1400
95	1450	1450
100	1500	1500
105	1550	1550.5
110	1600	1601
115	1650	1651.5
120	1700	1702
125	1750	1752.5
130	1800	1805.5
135	1850	1858.5
140	1900	1911.5
145	1950	1964.5
150	2000	2017.5

表 4. TMP236 Transfer Table

TEMPERATURE (°C)	V _{OUT} (mV) IDEAL LINEAR VALUES	V _{OUT} (mV) PIECEWISE LINEAR VALUES
-40	—	—
-35	—	—
-30	—	—
-25	—	—
-20	—	—
-15	—	—
-10	205	205
-5	303	303
0	400	400
5	498	498
10	595	595
15	693	693
20	790	790
25	888	888
30	985	985
35	1083	1083
40	1180	1180
45	1278	1278
50	1375	1375
55	1473	1473
60	1570	1570
65	1668	1668
70	1765	1765
75	1863	1863
80	1960	1960
85	2058	2058
90	2155	2155
95	2253	2253
100	2350	2350
105	2448	2448.5
110	2545	2547
115	2643	2645.4
120	2740	2743.9
125	2838	2842.4
130	—	—
135	—	—
140	—	—
145	—	—
150	—	—

7.4 Device Functional Modes

The singular functional mode of the TMP23x is an analog output directly proportional to temperature.

8 Application and Implementation

NOTE

Information in the following applications sections is not part of the TI component specification, and TI does not warrant its accuracy or completeness. TI's customers are responsible for determining suitability of components for their purposes. Customers should validate and test their design implementation to confirm system functionality.

8.1 Application Information

The features of the TMP235 make the series of devices designed for various general temperature-sensing applications. The TMP235 and TMP236 devices can operate down to a 2.3-V and a 3.1-V supply with 9- μ A power consumption, respectively. As a result, the series is designed for battery-powered applications. The TMP23x series is mounted in two surface mount technology packages (SC70 and SOT-23.)

8.2 Typical Application

8.2.1 Connection to an ADC

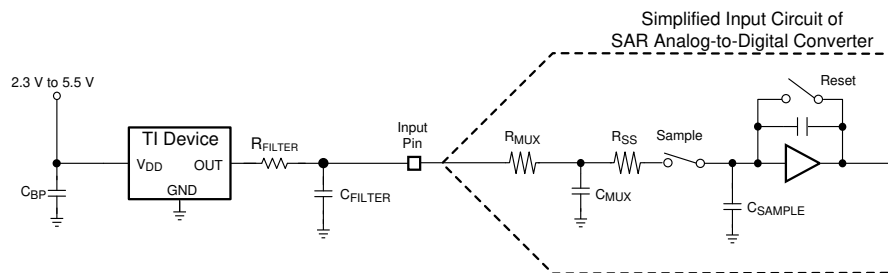

Figure 13. Suggested Connections to an ADC Input Stage

8.2.1.1 Design Requirements

See Figure 13 for suggested connections to an ADC input stage. Most CMOS-based ADCs have a sampled data comparator input structure. When the ADC charges the sampling capacitor (C_{SAMPLE}), the capacitor requires instantaneous charge from the output of the analog source temperature sensor, such as the TMP23x. Therefore, the output impedance of the temperature sensor can affect ADC performance. In most cases, adding an external capacitor (C_{FILTER}) mitigates design challenges. The TMP23x is specified and characterized with a 1000-pF maximum capacitive load (C_{LOAD}). Figure 13 shows C_{LOAD} as the sum of $C_{FILTER} + C_{MUX} + C_{SAMPLE}$. TI recommends maximizing the C_{FILTER} value while allowing for the maximum specified ADC input capacitance ($C_{MUX} + C_{SAMPLE}$) to limit the total C_{LOAD} at 1000 pF. In most cases, a 680-pF C_{FILTER} provides a reasonable allowance for ADC input capacitance to minimize ADC sampling error and reduce noise coupling. An optional series resistor (R_{FILTER}) and C_{FILTER} provides additional low-pass filtering to reject system level noise. TI recommends placing R_{FILTER} and C_{FILTER} as close as possible to the ADC input for optimal performance.

8.2.1.2 Detailed Design Procedure

Depending on the input characteristics of the ADC, an external C_{FILTER} may be required. The value of C_{FILTER} depends on the size of the sampling capacitor (C_{SAMPLE}) and the sampling frequency while observing a maximum C_{LOAD} of 1000 pF. The capacitor requirements can vary because the input stages of all ADCs are not identical. Figure 13 shows a general ADC application as an example only.

Typical Application (continued)

8.2.1.3 Application Curve

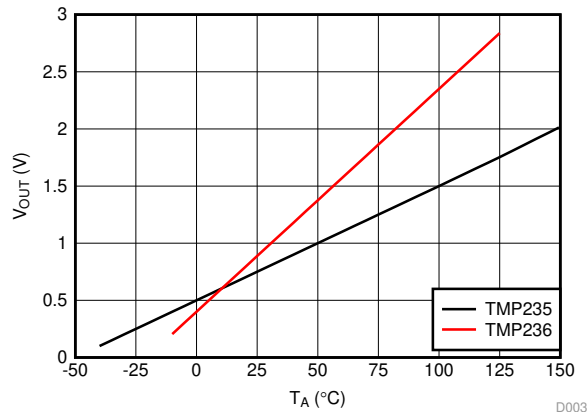

Figure 14. Output Voltage vs. Ambient

9 Power Supply Recommendations

The low supply current and supply range of the TMP23x allow the device to be easily powered from many sources.



Power supply bypassing is strongly recommended. In noisy environments, TI recommends to add a filter with 0.1- μ F capacitor and 100- Ω resistor between external supply and V_{DD} to limit the power supply noise. Larger capacitances may be required and are dependent on the noise of the power supply.

10 Layout

10.1 Layout Guidelines

The layout of the TMP23x series is simple. If a power supply bypass capacitor is used, the capacitor must be connected as [Layout Examples](#) shows.

10.2 Layout Examples

-  VIA to ground plane
-  VIA to power plane

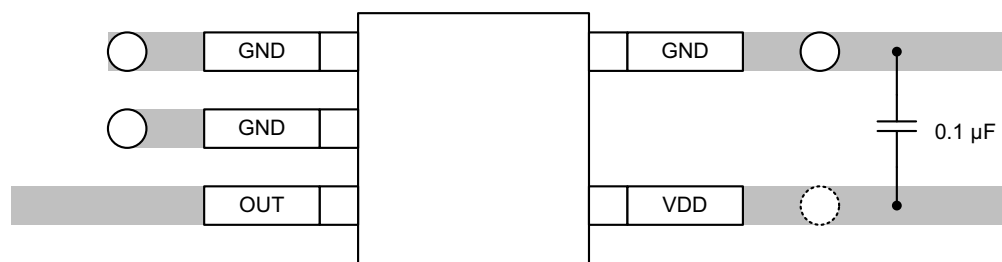

Figure 15. Recommended Layout: SC70 Package

11 デバイスおよびドキュメントのサポート

11.1 関連リンク

次の表に、クイック・アクセス・リンクを示します。カテゴリには、技術資料、サポートおよびコミュニティ・リソース、ツールとソフトウェア、およびご注文へのクイック・アクセスが含まれます。

表 5. 関連リンク

製品	プロダクト・フォルダ	ご注文はこちら	技術資料	ツールとソフトウェア	サポートとコミュニティ
TMP235	ここをクリック	ここをクリック	ここをクリック	ここをクリック	ここをクリック
TMP236	ここをクリック	ここをクリック	ここをクリック	ここをクリック	ここをクリック

11.2 ドキュメントの更新通知を受け取る方法

ドキュメントの更新についての通知を受け取るには、ti.comのデバイス製品フォルダを開いてください。右上の「アラートを受け取る」をクリックして登録すると、変更されたすべての製品情報に関するダイジェストを毎週受け取れます。変更の詳細については、修正されたドキュメントに含まれている改訂履歴をご覧ください。

11.3 コミュニティ・リソース

The following links connect to TI community resources. Linked contents are provided "AS IS" by the respective contributors. They do not constitute TI specifications and do not necessarily reflect TI's views; see TI's [Terms of Use](#).

TI E2E™ Online Community *TI's Engineer-to-Engineer (E2E) Community*. Created to foster collaboration among engineers. At e2e.ti.com, you can ask questions, share knowledge, explore ideas and help solve problems with fellow engineers.

Design Support *TI's Design Support* Quickly find helpful E2E forums along with design support tools and contact information for technical support.

11.4 商標

E2E is a trademark of Texas Instruments.
All other trademarks are the property of their respective owners.

11.5 静電気放電に関する注意事項



すべての集積回路は、適切なESD保護方法を用いて、取扱いと保存を行うようにして下さい。

静電気放電はわずかな性能の低下から完全なデバイスの故障に至るまで、様々な損傷を与えます。高精度の集積回路は、損傷に対して敏感であり、極めてわずかなパラメータの変化により、デバイスに規定された仕様に適合しなくなる場合があります。

11.6 Glossary

SLYZ022 — *TI Glossary*.

This glossary lists and explains terms, acronyms, and definitions.

12 メカニカル、パッケージ、および注文情報

以降のページには、メカニカル、パッケージ、および注文に関する情報が記載されています。この情報は、そのデバイスについて利用可能な最新のデータです。このデータは予告なく変更されることがあり、ドキュメントが改訂される場合もあります。本データシートのブラウザ版を使用されている場合は、画面左側の説明をご覧ください。

PACKAGING INFORMATION

Orderable Device	Status (1)	Package Type	Package Drawing	Pins	Package Qty	Eco Plan (2)	Lead finish/ Ball material (6)	MSL Peak Temp (3)	Op Temp (°C)	Device Marking (4/5)	Samples
TMP235A2DBZR	ACTIVE	SOT-23	DBZ	3	3000	RoHS & Green	NIPDAU SN NIPDAUAG	Level-1-260C-UNLIM	-40 to 150	2352	Samples
TMP235A2DBZT	OBSOLETE	SOT-23	DBZ	3		TBD	Call TI	Call TI	-40 to 150	2352	
TMP235A2DCKR	ACTIVE	SC70	DCK	5	3000	RoHS & Green	NIPDAU SN NIPDAUAG	Level-1-260C-UNLIM	-40 to 150	19L	Samples
TMP235A2DCKT	OBSOLETE	SC70	DCK	5		TBD	Call TI	Call TI	-40 to 150	19L	
TMP235A4DBZR	ACTIVE	SOT-23	DBZ	3	3000	RoHS & Green	NIPDAU SN NIPDAUAG	Level-1-260C-UNLIM	-40 to 150	2354	Samples
TMP235A4DBZT	OBSOLETE	SOT-23	DBZ	3		TBD	Call TI	Call TI	-40 to 150	2354	
TMP235A4DCKR	ACTIVE	SC70	DCK	5	3000	RoHS & Green	NIPDAU SN NIPDAUAG	Level-1-260C-UNLIM	-40 to 150	19M	Samples
TMP235A4DCKT	OBSOLETE	SC70	DCK	5		TBD	Call TI	Call TI	-40 to 150	19M	
TMP236A2DBZR	ACTIVE	SOT-23	DBZ	3	3000	RoHS & Green	NIPDAU SN NIPDAUAG	Level-1-260C-UNLIM	-10 to 125	2362	Samples
TMP236A2DBZT	OBSOLETE	SOT-23	DBZ	3		TBD	Call TI	Call TI	-10 to 125	2362	
TMP236A2DCKR	ACTIVE	SC70	DCK	5	3000	RoHS & Green	NIPDAU SN NIPDAUAG	Level-1-260C-UNLIM	-10 to 125	1BS	Samples
TMP236A2DCKT	OBSOLETE	SC70	DCK	5		TBD	Call TI	Call TI	-10 to 125	1BS	
TMP236A4DBZR	ACTIVE	SOT-23	DBZ	3	3000	RoHS & Green	NIPDAU SN NIPDAUAG	Level-1-260C-UNLIM	-10 to 125	2364	Samples
TMP236A4DBZT	OBSOLETE	SOT-23	DBZ	3		TBD	Call TI	Call TI	-10 to 125	2364	
TMP236A4DCKR	ACTIVE	SC70	DCK	5	3000	RoHS & Green	NIPDAU SN NIPDAUAG	Level-1-260C-UNLIM	-10 to 125	1BT	Samples
TMP236A4DCKT	OBSOLETE	SC70	DCK	5		TBD	Call TI	Call TI	-10 to 125	1BT	

(1) The marketing status values are defined as follows:

ACTIVE: Product device recommended for new designs.

LIFEBUY: TI has announced that the device will be discontinued, and a lifetime-buy period is in effect.

NRND: Not recommended for new designs. Device is in production to support existing customers, but TI does not recommend using this part in a new design.

PREVIEW: Device has been announced but is not in production. Samples may or may not be available.

OBSOLETE: TI has discontinued the production of the device.

(2) **RoHS:** TI defines "RoHS" to mean semiconductor products that are compliant with the current EU RoHS requirements for all 10 RoHS substances, including the requirement that RoHS substance do not exceed 0.1% by weight in homogeneous materials. Where designed to be soldered at high temperatures, "RoHS" products are suitable for use in specified lead-free processes. TI may reference these types of products as "Pb-Free".

RoHS Exempt: TI defines "RoHS Exempt" to mean products that contain lead but are compliant with EU RoHS pursuant to a specific EU RoHS exemption.

Green: TI defines "Green" to mean the content of Chlorine (Cl) and Bromine (Br) based flame retardants meet JS709B low halogen requirements of ≤ 1000 ppm threshold. Antimony trioxide based flame retardants must also meet the ≤ 1000 ppm threshold requirement.

(3) MSL, Peak Temp. - The Moisture Sensitivity Level rating according to the JEDEC industry standard classifications, and peak solder temperature.

(4) There may be additional marking, which relates to the logo, the lot trace code information, or the environmental category on the device.

(5) Multiple Device Markings will be inside parentheses. Only one Device Marking contained in parentheses and separated by a "~" will appear on a device. If a line is indented then it is a continuation of the previous line and the two combined represent the entire Device Marking for that device.

(6) Lead finish/Ball material - Orderable Devices may have multiple material finish options. Finish options are separated by a vertical ruled line. Lead finish/Ball material values may wrap to two lines if the finish value exceeds the maximum column width.

Important Information and Disclaimer: The information provided on this page represents TI's knowledge and belief as of the date that it is provided. TI bases its knowledge and belief on information provided by third parties, and makes no representation or warranty as to the accuracy of such information. Efforts are underway to better integrate information from third parties. TI has taken and continues to take reasonable steps to provide representative and accurate information but may not have conducted destructive testing or chemical analysis on incoming materials and chemicals. TI and TI suppliers consider certain information to be proprietary, and thus CAS numbers and other limited information may not be available for release.

In no event shall TI's liability arising out of such information exceed the total purchase price of the TI part(s) at issue in this document sold by TI to Customer on an annual basis.

OTHER QUALIFIED VERSIONS OF TMP235, TMP236 :

- Automotive : [TMP235-Q1](#), [TMP236-Q1](#)

NOTE: Qualified Version Definitions:

- Automotive - Q100 devices qualified for high-reliability automotive applications targeting zero defects

TAPE AND REEL INFORMATION



QUADRANT ASSIGNMENTS FOR PIN 1 ORIENTATION IN TAPE



*All dimensions are nominal

Device	Package Type	Package Drawing	Pins	SPQ	Reel Diameter (mm)	Reel Width W1 (mm)	A0 (mm)	B0 (mm)	K0 (mm)	P1 (mm)	W (mm)	Pin1 Quadrant
TMP235A2DBZR	SOT-23	DBZ	3	3000	180.0	8.4	3.2	2.85	1.3	4.0	8.0	Q3
TMP235A2DCKR	SC70	DCK	5	3000	180.0	8.4	2.3	2.5	1.2	4.0	8.0	Q3
TMP235A4DBZR	SOT-23	DBZ	3	3000	180.0	8.4	3.2	2.85	1.3	4.0	8.0	Q3
TMP235A4DCKR	SC70	DCK	5	3000	180.0	8.4	2.3	2.5	1.2	4.0	8.0	Q3
TMP236A2DBZR	SOT-23	DBZ	3	3000	180.0	8.4	3.2	2.85	1.3	4.0	8.0	Q3
TMP236A2DCKR	SC70	DCK	5	3000	180.0	8.4	2.3	2.5	1.2	4.0	8.0	Q3
TMP236A4DBZR	SOT-23	DBZ	3	3000	180.0	8.4	3.2	2.85	1.3	4.0	8.0	Q3
TMP236A4DCKR	SC70	DCK	5	3000	180.0	8.4	2.3	2.5	1.2	4.0	8.0	Q3

TAPE AND REEL BOX DIMENSIONS

*All dimensions are nominal

Device	Package Type	Package Drawing	Pins	SPQ	Length (mm)	Width (mm)	Height (mm)
TMP235A2DBZR	SOT-23	DBZ	3	3000	210.0	185.0	35.0
TMP235A2DCKR	SC70	DCK	5	3000	210.0	185.0	35.0
TMP235A4DBZR	SOT-23	DBZ	3	3000	210.0	185.0	35.0
TMP235A4DCKR	SC70	DCK	5	3000	210.0	185.0	35.0
TMP236A2DBZR	SOT-23	DBZ	3	3000	210.0	185.0	35.0
TMP236A2DCKR	SC70	DCK	5	3000	210.0	185.0	35.0
TMP236A4DBZR	SOT-23	DBZ	3	3000	210.0	185.0	35.0
TMP236A4DCKR	SC70	DCK	5	3000	210.0	185.0	35.0

DCK0005A



PACKAGE OUTLINE

SOT - 1.1 max height

SMALL OUTLINE TRANSISTOR

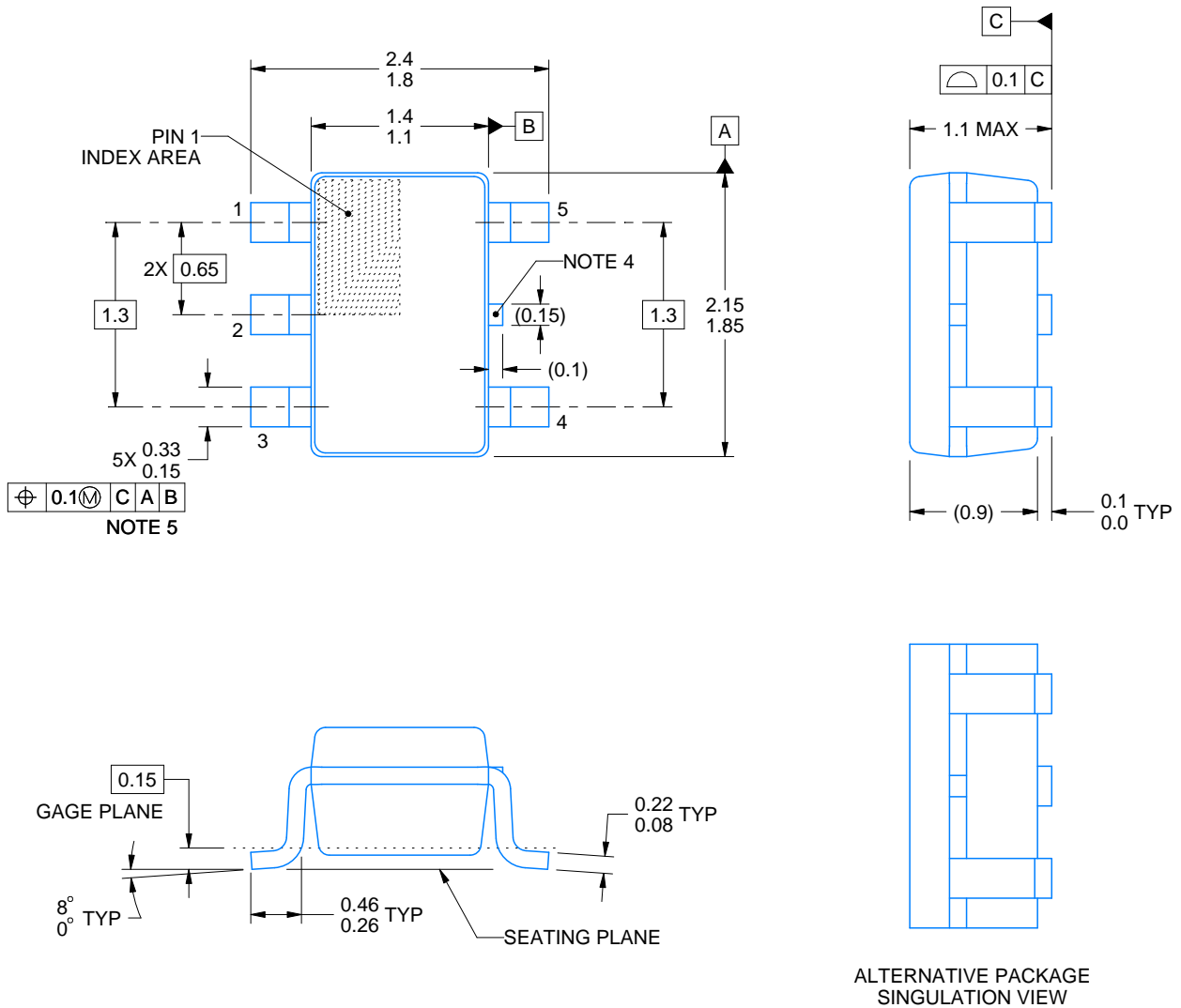

4214834/E 06/2024

NOTES:

1. All linear dimensions are in millimeters. Any dimensions in parenthesis are for reference only. Dimensioning and tolerancing per ASME Y14.5M.
2. This drawing is subject to change without notice.
3. Reference JEDEC MO-203.
4. Support pin may differ or may not be present.
5. Lead width does not comply with JEDEC.
6. Body dimensions do not include mold flash, protrusions, or gate burrs. Mold flash, protrusions, or gate burrs shall not exceed 0.25mm per side

EXAMPLE BOARD LAYOUT

DCK0005A

SOT - 1.1 max height

SMALL OUTLINE TRANSISTOR



LAND PATTERN EXAMPLE
EXPOSED METAL SHOWN
SCALE:18X



SOLDER MASK DETAILS

4214834/E 06/2024

NOTES: (continued)

- 7. Publication IPC-7351 may have alternate designs.
- 8. Solder mask tolerances between and around signal pads can vary based on board fabrication site.

EXAMPLE STENCIL DESIGN

DCK0005A

SOT - 1.1 max height

SMALL OUTLINE TRANSISTOR



SOLDER PASTE EXAMPLE
BASED ON 0.125 THICK STENCIL
SCALE: 18X

4214834/E 06/2024

NOTES: (continued)

9. Laser cutting apertures with trapezoidal walls and rounded corners may offer better paste release. IPC-7525 may have alternate design recommendations.
10. Board assembly site may have different recommendations for stencil design.

DBZ0003A



PACKAGE OUTLINE

SOT-23 - 1.12 mm max height

SMALL OUTLINE TRANSISTOR



4214838/F 08/2024

NOTES:

1. All linear dimensions are in millimeters. Any dimensions in parenthesis are for reference only. Dimensioning and tolerancing per ASME Y14.5M.
2. This drawing is subject to change without notice.
3. Reference JEDEC registration TO-236, except minimum foot length.
4. Support pin may differ or may not be present.
5. Body dimensions do not include mold flash, protrusions, or gate burrs. Mold flash, protrusions, or gate burrs shall not exceed 0.25mm per side

EXAMPLE BOARD LAYOUT

DBZ0003A

SOT-23 - 1.12 mm max height

SMALL OUTLINE TRANSISTOR



LAND PATTERN EXAMPLE
SCALE:15X



SOLDER MASK DETAILS

4214838/F 08/2024

NOTES: (continued)

- 5. Publication IPC-7351 may have alternate designs.
- 6. Solder mask tolerances between and around signal pads can vary based on board fabrication site.

EXAMPLE STENCIL DESIGN

DBZ0003A

SOT-23 - 1.12 mm max height

SMALL OUTLINE TRANSISTOR



SOLDER PASTE EXAMPLE
BASED ON 0.125 THICK STENCIL
SCALE:15X

4214838/F 08/2024

NOTES: (continued)

7. Laser cutting apertures with trapezoidal walls and rounded corners may offer better paste release. IPC-7525 may have alternate design recommendations.
8. Board assembly site may have different recommendations for stencil design.

重要なお知らせと免責事項

TI は、技術データと信頼性データ (データシートを含みます)、設計リソース (リファレンス・デザインを含みます)、アプリケーションや設計に関する各種アドバイス、Web ツール、安全性情報、その他のリソースを、欠陥が存在する可能性のある「現状のまま」提供しており、商品性および特定目的に対する適合性の黙示保証、第三者の知的財産権の非侵害保証を含むいかなる保証も、明示的または黙示的にかかわらず拒否します。

これらのリソースは、TI 製品を使用する設計の経験を積んだ開発者への提供を意図したものです。(1) お客様のアプリケーションに適した TI 製品の選定、(2) お客様のアプリケーションの設計、検証、試験、(3) お客様のアプリケーションに該当する各種規格や、その他のあらゆる安全性、セキュリティ、規制、または他の要件への確実な適合に関する責任を、お客様のみが単独で負うものとします。

上記の各種リソースは、予告なく変更される可能性があります。これらのリソースは、リソースで説明されている TI 製品を使用するアプリケーションの開発の目的でのみ、TI はその使用をお客様に許諾します。これらのリソースに関して、他の目的で複製することや掲載することは禁止されています。TI や第三者の知的財産権のライセンスが付与されている訳ではありません。お客様は、これらのリソースを自身で使用した結果発生するあらゆる申し立て、損害、費用、損失、責任について、TI およびその代理人を完全に補償するものとし、TI は一切の責任を拒否します。

TI の製品は、[TI の販売条件](#)、または [ti.com](#) やかかる TI 製品の関連資料などのいずれかを通じて提供する適用可能な条項の下で提供されています。TI がこれらのリソースを提供することは、適用される TI の保証または他の保証の放棄の拡大や変更を意味するものではありません。

お客様がいかなる追加条項または代替条項を提案した場合でも、TI はそれらに異議を唱え、拒否します。

郵送先住所 : Texas Instruments, Post Office Box 655303, Dallas, Texas 75265
Copyright © 2024, Texas Instruments Incorporated