

# TMUX721x 44V、低 RON、1:1 (SPST)、4 チャンネル高精度スイッチ、ラッチアップフリー、1.8V ロジック

## 1 特長

- ラッチアップフリー
- 両電源電圧範囲:  $\pm 4.5V \sim \pm 22V$
- 単電源電圧範囲:  $4.5V \sim 44V$
- 低いオン抵抗:  $2\Omega$
- 大電流のサポート: 220mA (最大値) (TSSOP)
- $-40^{\circ}C \sim +125^{\circ}C$  の動作温度範囲
- ロジックピンにプルダウン抵抗を内蔵
- 1.8V ロジック互換
- フェイルセーフロジック
- レールツーレール動作
- 双方向動作

## 2 アプリケーション

- EV 充電ステーション向け電源モジュール
- 先進運転支援システム (ADAS)
- 車載ゲートウェイ
- アナログおよびデジタルの多重化 / 多重分離
- 車載ヘッド・ユニット
- テレマティクス制御ユニット
- 緊急通話 (eCall)
- インフォテインメント
- 車体制御モジュール (BCM)
- ボディ・エレクトロニクス / 照明
- バッテリー管理システム (BMS)
- HVAC コントローラ・モジュール
- ADAS ドメイン・コントローラ

## 3 概要

TMUX7212 は、独立して選択できる 4 つの 1:1 単極単投 (SPST) スイッチ チャンネルを備えた相補型金属酸化膜半導体 (CMOS) スイッチです。このデバイスは単一電源 ( $4.5V \sim 44V$ )、デュアル電源 ( $\pm 4.5V \sim \pm 22V$ )、非対称電源 ( $V_{DD} = 12V$ ,  $V_{SS} = -5V$  など) で動作します。TMUX721x は、ソース (Sx) およびドレイン (Dx) ピンで、 $V_{SS}$  から  $V_{DD}$  までの範囲の双方向アナログおよびデジタル信号をサポートします。

TMUX721x のスイッチは、SELx ピンの適切なロジック制御入力によって制御されます。TMUX721x は高精度スイッチおよびマルチプレクサファミリの製品であり、オンおよびオフ時のリーク電流が非常に小さいため、高精度の測定用途に使用できます。

TMUX721x ファミリーはラッチアップフリーであるため、過電圧イベントによってよく発生するデバイス内の寄生構造間の好ましくない大電流イベントを防止できます。ラッチアップ状態は通常、電源レールがオフにされるまで継続するため、デバイスの障害の原因となる場合があります。このラッチアップフリーという特長により、TMUX721x は過酷な環境でも使用できます。

表 3-1. 製品情報

部品番号 (1)	アクティブロジック	パッケージ (2)
TMUX7211	ロジック Low	PW (TSSOP, 16)
TMUX7212	ロジック High	RUM (WQFN, 16)
TMUX7213	ロジック Low + ロジック High	

(1) 製品比較表を参照してください。

(2) 詳細については、セクション 12 を参照してください。



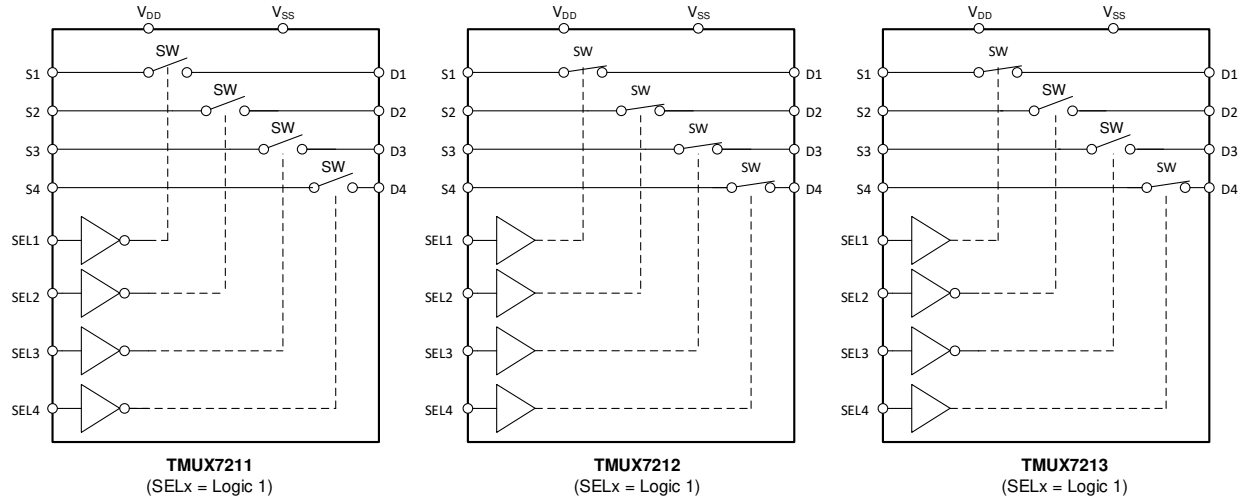

TMUX721x 機能ブロック図

## Table of Contents

<b>1 特長</b> .....	1	7.7 Charge Injection.....	23
<b>2 アプリケーション</b> .....	1	7.8 Off Isolation.....	23
<b>3 概要</b> .....	1	7.9 Channel-to-Channel Crosstalk.....	24
<b>4 Device Comparison Table</b> .....	4	7.10 Bandwidth.....	24
<b>5 Pin Configuration and Functions</b> .....	4	7.11 THD + Noise.....	25
<b>6 Specifications</b> .....	5	7.12 Power Supply Rejection Ratio (PSRR).....	25
6.1 Absolute Maximum Ratings.....	5	<b>8 Detailed Description</b> .....	26
6.2 ESD Ratings.....	5	8.1 Overview.....	26
6.3 Thermal Information.....	6	8.2 Functional Block Diagram.....	26
6.4 Recommended Operating Conditions.....	6	8.3 Feature Description.....	26
6.5 Source or Drain Continuous Current.....	6	8.4 Device Functional Modes.....	29
6.6 ±15 V Dual Supply: Electrical Characteristics .....	7	8.5 Truth Tables.....	29
6.7 ±15 V Dual Supply: Switching Characteristics .....	8	<b>9 Application and Implementation</b> .....	30
6.8 ±20 V Dual Supply: Electrical Characteristics.....	9	9.1 Application Information.....	30
6.9 ±20 V Dual Supply: Switching Characteristics.....	10	9.2 Typical Application .....	30
6.10 44 V Single Supply: Electrical Characteristics .....	11	9.3 Power Supply Recommendations.....	31
6.11 44 V Single Supply: Switching Characteristics .....	12	9.4 Layout.....	32
6.12 12 V Single Supply: Electrical Characteristics .....	13	<b>10 Device and Documentation Support</b> .....	34
6.13 12 V Single Supply: Switching Characteristics .....	14	10.1 Documentation Support.....	34
6.14 Typical Characteristics.....	15	10.2 ドキュメントの更新通知を受け取る方法.....	34
<b>7 Parameter Measurement Information</b> .....	20	10.3 サポート・リソース.....	34
7.1 On-Resistance.....	20	10.4 Trademarks.....	34
7.2 Off-Leakage Current.....	20	10.5 静電気放電に関する注意事項.....	34
7.3 On-Leakage Current.....	21	10.6 用語集.....	34
7.4 $t_{ON}$ and $t_{OFF}$ Time.....	21	<b>11 Revision History</b> .....	35
7.5 $t_{ON}$ (VDD) Time.....	22	<b>12 Mechanical, Packaging, and Orderable Information</b> .....	35
7.6 Propagation Delay.....	22		

## 4 Device Comparison Table

PRODUCT	DESCRIPTION
TMUX7211	Low-Leakage-Current, Precision, 4-Channel, 1:1 (SPST) Switches (Logic Low)
TMUX7212	Low-Leakage-Current, Precision, 4-Channel, 1:1 (SPST) Switches (Logic High)
TMUX7213	Low-Leakage-Current, Precision, 4-Channel, 1:1 (SPST) Switches (Logic Low + Logic High)

## 5 Pin Configuration and Functions



図 5-1. PW Package, 16-Pin TSSOP (Top View)



図 5-2. RUM Package, 16-Pin WQFN (Top View)

表 5-1. Pin Functions

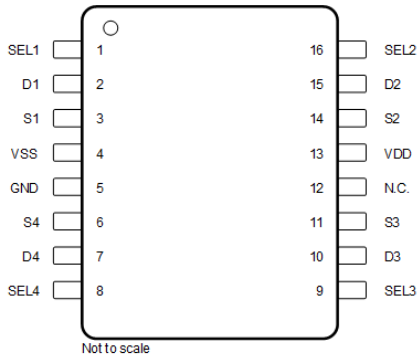
PIN			TYPE <sup>(1)</sup>	DESCRIPTION <sup>(2)</sup>
NAME	TSSOP	WQFN		
D1	2	16	I/O	Drain pin 1. Can be an input or output.
D2	15	13	I/O	Drain pin 2. Can be an input or output.
D3	10	8	I/O	Drain pin 3. Can be an input or output.
D4	7	5	I/O	Drain pin 4. Can be an input or output.
GND	5	3	P	Ground (0 V) reference
N.C.	12	10	—	No internal connection. Can be shorted to GND or left floating.
S1	3	1	I/O	Source pin 1. Can be an input or output.
S2	14	12	I/O	Source pin 2. Can be an input or output.
S3	11	9	I/O	Source pin 3. Can be an input or output.
S4	6	4	I/O	Source pin 4. Can be an input or output.
SEL1	1	15	I	Logic control input 1, has internal 4 M $\Omega$ pull-down resistor. Controls channel 1 state as shown in <a href="#">セクション 8.5</a> .
SEL2	16	14	I	Logic control input 2, has internal 4 M $\Omega$ pull-down resistor. Controls channel 2 state as shown in <a href="#">セクション 8.5</a> .
SEL3	9	7	I	Logic control input 3, has internal 4 M $\Omega$ pull-down resistor. Controls channel 3 state as shown in <a href="#">セクション 8.5</a> .
SEL4	8	6	I	Logic control input 4, has internal 4 M $\Omega$ pull-down resistor. Controls channel 4 state as shown in <a href="#">セクション 8.5</a> .
VDD	13	11	P	Positive power supply. This pin is the most positive power-supply potential. For reliable operation, connect a decoupling capacitor ranging from 0.1 $\mu$ F to 10 $\mu$ F between V <sub>DD</sub> and GND.
VSS	4	2	P	Negative power supply. This pin is the most negative power-supply potential. In single-supply applications, this pin can be connected to ground. For reliable operation, connect a decoupling capacitor ranging from 0.1 $\mu$ F to 10 $\mu$ F between V <sub>SS</sub> and GND.
Thermal Pad			—	The thermal pad is not connected internally. No requirement to solder this pad, if connected it is recommended that the pad be left floating or tied to GND

(1) I = input, O = output, I/O = input and output, P = power.

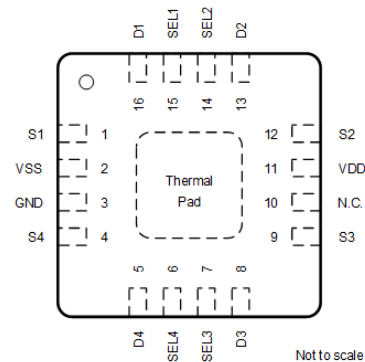
(2) Refer to [セクション 8.4](#) for what to do with unused pins.

## 6 Specifications

### 6.1 Absolute Maximum Ratings

over operating free-air temperature range (unless otherwise noted)<sup>(1) (2)</sup>

		MIN	MAX	UNIT
$V_{DD} - V_{SS}$	Supply voltage		48	V
$V_{DD}$		-0.5	48	V
$V_{SS}$		-48	0.5	V
$V_{SEL}$ or $V_{EN}$	Logic control input pin voltage (SELx)	-0.5	48	V
$I_{SEL}$ or $I_{EN}$	Logic control input pin current (SELx)	-30	30	mA
$V_S$ or $V_D$	Source or drain voltage (Sx, Dx)	$V_{SS}-0.5$	$V_{DD}+0.5$	V
$I_{IK}$	Diode clamp current <sup>(3)</sup>	-30	30	mA
$I_S$ or $I_D$ (CONT)	Source or drain continuous current (Sx, Dx)		$I_{DC} + 10\%$ <sup>(4)</sup>	mA
$T_A$	Ambient temperature	-55	150	°C
$T_{stg}$	Storage temperature	-65	150	°C
$T_J$	Junction temperature		150	°C
$P_{tot}$	Total power dissipation (QFN) <sup>(5)</sup>		1650	mW
	Total power dissipation (TSSOP) <sup>(5)</sup>		700	mW

- (1) Stresses beyond those listed under *Absolute Maximum Rating* may cause permanent damage to the device. These are stress ratings only, which do not imply functional operation of the device at these or any other conditions beyond those indicated under *Recommended Operating Condition*. Exposure to absolute-maximum-rated conditions for extended periods may affect device reliability.
- (2) All voltages are with respect to ground, unless otherwise specified.
- (3) Pins are diode-clamped to the power-supply rails. Over voltage signals must be voltage and current limited to maximum ratings.
- (4) Refer to *Source or Drain Continuous Current* table for  $I_{DC}$  specifications.
- (5) For QFN package:  $P_{tot}$  derates linearly above  $T_A = 70^\circ\text{C}$  by 24.2mW/°C.  
For TSSOP package:  $P_{tot} = 700$  mW (max) and derates linearly above  $T_A = 70^\circ\text{C}$  by 10.7mW/°C.

### 6.2 ESD Ratings

			VALUE	UNIT
<b>TMUX721x in PW package</b>				
$V_{(ESD)}$	Electrostatic discharge	Human body model (HBM), per ANSI/ESDA/ JEDEC JS-001, all pins <sup>(1)</sup>	±2000	V
		Charged device model (CDM), per JEDEC specification JESD22-C101, all pins <sup>(2)</sup>	±500	
<b>TMUX721x in RUM package</b>				
$V_{(ESD)}$	Electrostatic discharge	Human body model (HBM), per ANSI/ESDA/ JEDEC JS-001, all pins <sup>(1)</sup>	±2000	V
		Charged device model (CDM), per JEDEC specification JESD22-C101, all pins <sup>(2)</sup>	±500	

- (1) JEDEC document JEP155 states that 500-V HBM allows safe manufacturing with a standard ESD control process.
- (2) JEDEC document JEP157 states that 250-V CDM allows safe manufacturing with a standard ESD control process.

### 6.3 Thermal Information

THERMAL METRIC <sup>(1)</sup>		TMUX721x		UNIT
		PW (TSSOP)	RUM (WQFN)	
		16 PINS	16 PINS	
R <sub>θJA</sub>	Junction-to-ambient thermal resistance	94.5	41.5	°C/W
R <sub>θJC(top)</sub>	Junction-to-case (top) thermal resistance	25.5	25.1	°C/W
R <sub>θJB</sub>	Junction-to-board thermal resistance	41.1	16.5	°C/W
Ψ <sub>JT</sub>	Junction-to-top characterization parameter	1.1	0.3	°C/W
Ψ <sub>JB</sub>	Junction-to-board characterization parameter	40.4	16.4	°C/W
R <sub>θJC(bot)</sub>	Junction-to-case (bottom) thermal resistance	N/A	2.9	°C/W

(1) For more information about traditional and new thermal metrics, see the [Semiconductor and IC Package Thermal Metrics](#) application report.

### 6.4 Recommended Operating Conditions

over operating free-air temperature range (unless otherwise noted)

		MIN	NOM	MAX	UNIT
V <sub>DD</sub> – V <sub>SS</sub> <sup>(1)</sup>	Power supply voltage differential	4.5		44	V
V <sub>DD</sub>	Positive power supply voltage	4.5		44	V
V <sub>S</sub> or V <sub>D</sub>	Signal path input/output voltage (source or drain pin) (Sx, D)	V <sub>SS</sub>		V <sub>DD</sub>	V
V <sub>SEL</sub> or V <sub>EN</sub>	Address or enable pin voltage	0		44	V
I <sub>S</sub> or I <sub>D (CONT)</sub>	Source or drain continuous current (Sx, D)			I <sub>DC</sub> <sup>(2)</sup>	mA
T <sub>A</sub>	Ambient temperature	–40		125	°C

(1) V<sub>DD</sub> and V<sub>SS</sub> can be any value as long as 4.5 V ≤ (V<sub>DD</sub> – V<sub>SS</sub>) ≤ 44 V, and the minimum V<sub>DD</sub> is met.

(2) Refer to *Source or Drain Continuous Current* table for I<sub>DC</sub> specifications.

### 6.5 Source or Drain Continuous Current

at supply voltage of V<sub>DD</sub> ± 10%, V<sub>SS</sub> ± 10 % (unless otherwise noted)

CONTINUOUS CURRENT PER CHANNEL (I <sub>DC</sub> ) <sup>(2)</sup>		T <sub>A</sub> = 25°C	T <sub>A</sub> = 85°C	T <sub>A</sub> = 125°C	UNIT
PACKAGE	TEST CONDITIONS				
PW (TSSOP)	+44 V Dual Supply <sup>(1)</sup>	220	160	100	mA
	±15 V Dual Supply	220	160	100	mA
	+12 V Single Supply	190	130	90	mA
	±5 V Dual Supply	170	120	80	mA
	+5 V Single Supply	130	90	60	mA
RUM (WQFN)	+44 V Single Supply <sup>(1)</sup>	330	220	120	mA
	±15 V Dual Supply	330	220	120	mA
	+12 V Single Supply	260	180	110	mA
	±5 V Dual Supply	240	160	100	mA
	+5 V Single Supply	180	120	80	mA

(1) Specified for nominal supply voltage only.

(2) Refer to Total power dissipation (P<sub>tot</sub>) limits in *Absolute Maximum Ratings* table that must be followed with max continuous current specification.

## 6.6 ±15 V Dual Supply: Electrical Characteristics

$V_{DD} = +15\text{ V} \pm 10\%$ ,  $V_{SS} = -15\text{ V} \pm 10\%$ ,  $GND = 0\text{ V}$  (unless otherwise noted)

Typical at  $V_{DD} = +15\text{ V}$ ,  $V_{SS} = -15\text{ V}$ ,  $T_A = 25^\circ\text{C}$  (unless otherwise noted)

PARAMETER		TEST CONDITIONS	$T_A$	MIN	TYP	MAX	UNIT	
<b>ANALOG SWITCH</b>								
$R_{ON}$	On-resistance	$V_S = -10\text{ V to }+10\text{ V}$ $I_D = -10\text{ mA}$ Refer to <a href="#">On-Resistance</a>	25°C		2	2.7	$\Omega$	
			-40°C to +85°C			3.4	$\Omega$	
			-40°C to +125°C			4	$\Omega$	
$\Delta R_{ON}$	On-resistance mismatch between channels	$V_S = -10\text{ V to }+10\text{ V}$ $I_D = -10\text{ mA}$ Refer to <a href="#">On-Resistance</a>	25°C		0.1	0.18	$\Omega$	
			-40°C to +85°C			0.19	$\Omega$	
			-40°C to +125°C			0.21	$\Omega$	
$R_{ON\ FLAT}$	On-resistance flatness	$V_S = -10\text{ V to }+10\text{ V}$ $I_S = -10\text{ mA}$ Refer to <a href="#">On-Resistance</a>	25°C		0.2	0.46	$\Omega$	
			-40°C to +85°C			0.65	$\Omega$	
			-40°C to +125°C			0.7	$\Omega$	
$R_{ON\ DRIFT}$	On-resistance drift	$V_S = 0\text{ V}$ , $I_S = -10\text{ mA}$ Refer to <a href="#">On-Resistance</a>	-40°C to +125°C		0.008		$\Omega/^\circ\text{C}$	
$I_{S(OFF)}$	Source off leakage current <sup>(1)</sup>	$V_{DD} = 16.5\text{ V}$ , $V_{SS} = -16.5\text{ V}$ Switch state is off $V_S = +10\text{ V} / -10\text{ V}$ $V_D = -10\text{ V} / +10\text{ V}$ Refer to <a href="#">Off-Leakage Current</a>	25°C	-0.25	0.05	0.25	nA	
			-40°C to +85°C		-3		3	nA
			-40°C to +125°C		-20		20	nA
$I_{D(OFF)}$	Drain off leakage current <sup>(1)</sup>	$V_{DD} = 16.5\text{ V}$ , $V_{SS} = -16.5\text{ V}$ Switch state is off $V_S = +10\text{ V} / -10\text{ V}$ $V_D = -10\text{ V} / +10\text{ V}$ Refer to <a href="#">Off-Leakage Current</a>	25°C	-0.25	0.05	0.25	nA	
			-40°C to +85°C		-3		3	nA
			-40°C to +125°C		-20		20	nA
$I_{S(ON)}$ $I_{D(ON)}$	Channel on leakage current <sup>(2)</sup>	$V_{DD} = 16.5\text{ V}$ , $V_{SS} = -16.5\text{ V}$ Switch state is on $V_S = V_D = \pm 10\text{ V}$ Refer to <a href="#">On-Leakage Current</a>	25°C	-0.4	0.1	0.4	nA	
			-40°C to +85°C		-1		1	nA
			-40°C to +125°C		-3		3	nA
<b>LOGIC INPUTS (SEL / EN pins)</b>								
$V_{IH}$	Logic voltage high		-40°C to +125°C	1.3		44	V	
$V_{IL}$	Logic voltage low		-40°C to +125°C	0		0.8	V	
$I_{IH}$	Input leakage current		-40°C to +125°C		0.4	2	$\mu\text{A}$	
$I_{IL}$	Input leakage current		-40°C to +125°C	-0.1	-0.005		$\mu\text{A}$	
$C_{IN}$	Logic input capacitance		-40°C to +125°C		3.5		pF	
<b>POWER SUPPLY</b>								
$I_{DD}$	$V_{DD}$ supply current	$V_{DD} = 16.5\text{ V}$ , $V_{SS} = -16.5\text{ V}$ Logic inputs = 0 V, 5 V, or $V_{DD}$	25°C		35	56	$\mu\text{A}$	
			-40°C to +85°C			65	$\mu\text{A}$	
			-40°C to +125°C			80	$\mu\text{A}$	
$I_{SS}$	$V_{SS}$ supply current	$V_{DD} = 16.5\text{ V}$ , $V_{SS} = -16.5\text{ V}$ Logic inputs = 0 V, 5 V, or $V_{DD}$	25°C		5	20	$\mu\text{A}$	
			-40°C to +85°C			24	$\mu\text{A}$	
			-40°C to +125°C			35	$\mu\text{A}$	

(1) When  $V_S$  is positive,  $V_D$  is negative, or when  $V_S$  is negative,  $V_D$  is positive.

(2) When  $V_S$  is at a voltage potential,  $V_D$  is floating, or when  $V_D$  is at a voltage potential,  $V_S$  is floating.

## 6.7 ±15 V Dual Supply: Switching Characteristics

$V_{DD} = +15\text{ V} \pm 10\%$ ,  $V_{SS} = -15\text{ V} \pm 10\%$ ,  $GND = 0\text{ V}$  (unless otherwise noted)

Typical at  $V_{DD} = +15\text{ V}$ ,  $V_{SS} = -15\text{ V}$ ,  $T_A = 25^\circ\text{C}$  (unless otherwise noted)

PARAMETER		TEST CONDITIONS	$T_A$	MIN	TYP	MAX	UNIT
$t_{ON}$	Turn-on time from control input	$V_S = 10\text{ V}$ $R_L = 300\ \Omega$ , $C_L = 35\text{ pF}$ Refer to <a href="#">Turn-on and Turn-off Time</a>	25°C		100	175	ns
			-40°C to +85°C			205	ns
			-40°C to +125°C			225	ns
$t_{OFF}$	Turn-off time from control input	$V_S = 10\text{ V}$ $R_L = 300\ \Omega$ , $C_L = 35\text{ pF}$ Refer to <a href="#">Turn-on and Turn-off Time</a>	25°C		80	205	ns
			-40°C to +85°C			225	ns
			-40°C to +125°C			240	ns
$t_{BBM}$	Break-before-make time delay (TMUX7213 Only)	$V_S = 10\text{ V}$ , $R_L = 300\ \Omega$ , $C_L = 35\text{ pF}$	25°C		27		ns
			-40°C to +85°C		5		ns
			-40°C to +125°C		5		ns
$t_{ON(VDD)}$	Device turn on time ( $V_{DD}$ to output)	$V_{DD}$ rise time = 1 $\mu\text{s}$ $R_L = 300\ \Omega$ , $C_L = 35\text{ pF}$ Refer to <a href="#">Turn-on (VDD) Time</a>	25°C		0.17		ms
			-40°C to +85°C			0.18	ms
			-40°C to +125°C			0.18	ms
$t_{PD}$	Propagation delay	$R_L = 50\ \Omega$ , $C_L = 5\text{ pF}$ Refer to <a href="#">Propagation Delay</a>	25°C		260		ps
$Q_{INJ}$	Charge injection	$V_S = 0\text{ V}$ , $C_L = 100\text{ pF}$ Refer to <a href="#">Charge Injection</a>	25°C		60		pC
$O_{ISO}$	Off-isolation	$R_L = 50\ \Omega$ , $C_L = 5\text{ pF}$ $V_S = 0\text{ V}$ , $f = 100\text{ kHz}$ Refer to <a href="#">Off Isolation</a>	25°C		-70		dB
$O_{ISO}$	Off-isolation	$R_L = 50\ \Omega$ , $C_L = 5\text{ pF}$ $V_S = 0\text{ V}$ , $f = 1\text{ MHz}$ Refer to <a href="#">Off Isolation</a>	25°C		-50		dB
$X_{TALK}$	Crosstalk	$R_L = 50\ \Omega$ , $C_L = 5\text{ pF}$ $V_S = 0\text{ V}$ , $f = 100\text{ kHz}$ Refer to <a href="#">Crosstalk</a>	25°C		-114		dB
$X_{TALK}$	Crosstalk	$R_L = 50\ \Omega$ , $C_L = 5\text{ pF}$ $V_S = 0\text{ V}$ , $f = 1\text{ MHz}$ Refer to <a href="#">Crosstalk</a>	25°C		-93		dB
BW	-3dB Bandwidth	$R_L = 50\ \Omega$ , $C_L = 5\text{ pF}$ $V_S = 0\text{ V}$ Refer to <a href="#">Bandwidth</a>	25°C		56		MHz
$I_L$	Insertion loss	$R_L = 50\ \Omega$ , $C_L = 5\text{ pF}$ $V_S = 0\text{ V}$ , $f = 1\text{ MHz}$	25°C		-0.15		dB
ACPSRR	AC Power Supply Rejection Ratio	$V_{PP} = 0.62\text{ V}$ on $V_{DD}$ and $V_{SS}$ $R_L = 50\ \Omega$ , $C_L = 5\text{ pF}$ , $f = 1\text{ MHz}$ Refer to <a href="#">ACPSRR</a>	25°C		-68		dB
THD+N	Total Harmonic Distortion + Noise	$V_{PP} = 15\text{ V}$ , $V_{BIAS} = 0\text{ V}$ $R_L = 10\text{ k}\Omega$ , $C_L = 5\text{ pF}$ , $f = 20\text{ Hz}$ to $20\text{ kHz}$ Refer to <a href="#">THD + Noise</a>	25°C		0.0004		%
$C_{S(OFF)}$	Source off capacitance	$V_S = 0\text{ V}$ , $f = 1\text{ MHz}$	25°C		28		pF
$C_{D(OFF)}$	Drain off capacitance	$V_S = 0\text{ V}$ , $f = 1\text{ MHz}$	25°C		45		pF
$C_{S(ON)}$ , $C_{D(ON)}$	On capacitance	$V_S = 0\text{ V}$ , $f = 1\text{ MHz}$	25°C		145		pF



## 6.8 ±20 V Dual Supply: Electrical Characteristics

$V_{DD} = +20\text{ V} \pm 10\%$ ,  $V_{SS} = -20\text{ V} \pm 10\%$ ,  $GND = 0\text{ V}$  (unless otherwise noted)

Typical at  $V_{DD} = +20\text{ V}$ ,  $V_{SS} = -20\text{ V}$ ,  $T_A = 25^\circ\text{C}$  (unless otherwise noted)

PARAMETER		TEST CONDITIONS	$T_A$	MIN	TYP	MAX	UNIT	
<b>ANALOG SWITCH</b>								
$R_{ON}$	On-resistance	$V_S = -15\text{ V to }+15\text{ V}$ $I_D = -10\text{ mA}$ Refer to <a href="#">On-Resistance</a>	25°C	1.7	2.5		$\Omega$	
			-40°C to +85°C			3	$\Omega$	
			-40°C to +125°C			3.6	$\Omega$	
$\Delta R_{ON}$	On-resistance mismatch between channels	$V_S = -15\text{ V to }+15\text{ V}$ $I_D = -10\text{ mA}$ Refer to <a href="#">On-Resistance</a>	25°C	0.1	0.18		$\Omega$	
			-40°C to +85°C			0.19	$\Omega$	
			-40°C to +125°C			0.21	$\Omega$	
$R_{ON\text{ FLAT}}$	On-resistance flatness	$V_S = -15\text{ V to }+15\text{ V}$ $I_S = -10\text{ mA}$ Refer to <a href="#">On-Resistance</a>	25°C	0.3	0.6		$\Omega$	
			-40°C to +85°C			0.8	$\Omega$	
			-40°C to +125°C			0.95	$\Omega$	
$R_{ON\text{ DRIFT}}$	On-resistance drift	$V_S = 0\text{ V}$ , $I_S = -10\text{ mA}$ Refer to <a href="#">On-Resistance</a>	-40°C to +125°C	0.008			$\Omega/^\circ\text{C}$	
$I_{S(OFF)}$	Source off leakage current <sup>(1)</sup>	$V_{DD} = 22\text{ V}$ , $V_{SS} = -22\text{ V}$ Switch state is off $V_S = +15\text{ V} / -15\text{ V}$ $V_D = -15\text{ V} / +15\text{ V}$ Refer to <a href="#">Off-Leakage Current</a>	25°C	-1	0.05	1	nA	
			-40°C to +85°C				4.5	nA
			-40°C to +125°C				33	nA
$I_{D(OFF)}$	Drain off leakage current <sup>(1)</sup>	$V_{DD} = 22\text{ V}$ , $V_{SS} = -22\text{ V}$ Switch state is off $V_S = +15\text{ V} / -15\text{ V}$ $V_D = -15\text{ V} / +15\text{ V}$ Refer to <a href="#">Off-Leakage Current</a>	25°C	-1	0.1	1	nA	
			-40°C to +85°C				4.5	nA
			-40°C to +125°C				33	nA
$I_{S(ON)}$ $I_{D(ON)}$	Channel on leakage current <sup>(2)</sup>	$V_{DD} = 22\text{ V}$ , $V_{SS} = -22\text{ V}$ Switch state is on $V_S = V_D = \pm 15\text{ V}$ Refer to <a href="#">On-Leakage Current</a>	25°C	-1	0.1	1	nA	
			-40°C to +85°C				1.5	nA
			-40°C to +125°C				8	nA
<b>LOGIC INPUTS (SEL / EN pins)</b>								
$V_{IH}$	Logic voltage high		-40°C to +125°C	1.3		44	V	
$V_{IL}$	Logic voltage low		-40°C to +125°C	0		0.8	V	
$I_{IH}$	Input leakage current		-40°C to +125°C		0.4	2	$\mu\text{A}$	
$I_{IL}$	Input leakage current		-40°C to +125°C	-0.1	-0.005		$\mu\text{A}$	
$C_{IN}$	Logic input capacitance		-40°C to +125°C		3.5		pF	
<b>POWER SUPPLY</b>								
$I_{DD}$	$V_{DD}$ supply current	$V_{DD} = 22\text{ V}$ , $V_{SS} = -22\text{ V}$ Logic inputs = 0 V, 5 V, or $V_{DD}$	25°C	33	65		$\mu\text{A}$	
			-40°C to +85°C				74	$\mu\text{A}$
			-40°C to +125°C				90	$\mu\text{A}$
$I_{SS}$	$V_{SS}$ supply current	$V_{DD} = 22\text{ V}$ , $V_{SS} = -22\text{ V}$ Logic inputs = 0 V, 5 V, or $V_{DD}$	25°C	7	26		$\mu\text{A}$	
			-40°C to +85°C				30	$\mu\text{A}$
			-40°C to +125°C				45	$\mu\text{A}$

(1) When  $V_S$  is positive,  $V_D$  is negative, or when  $V_S$  is negative,  $V_D$  is positive.

(2) When  $V_S$  is at a voltage potential,  $V_D$  is floating, or when  $V_D$  is at a voltage potential,  $V_S$  is floating.

## 6.9 ±20 V Dual Supply: Switching Characteristics

$V_{DD} = +20\text{ V} \pm 10\%$ ,  $V_{SS} = -20\text{ V} \pm 10\%$ ,  $GND = 0\text{ V}$  (unless otherwise noted)

Typical at  $V_{DD} = +20\text{ V}$ ,  $V_{SS} = -20\text{ V}$ ,  $T_A = 25^\circ\text{C}$  (unless otherwise noted)

PARAMETER		TEST CONDITIONS	$T_A$	MIN	TYP	MAX	UNIT
$t_{ON}$	Turn-on time from control input	$V_S = 10\text{ V}$ $R_L = 300\ \Omega$ , $C_L = 35\text{ pF}$ Refer to <a href="#">Turn-on and Turn-off Time</a>	25°C		100	185	ns
			-40°C to +85°C			210	ns
			-40°C to +125°C			230	ns
$t_{OFF}$	Turn-off time from control input	$V_S = 10\text{ V}$ $R_L = 300\ \Omega$ , $C_L = 35\text{ pF}$ Refer to <a href="#">Turn-on and Turn-off Time</a>	25°C		90	210	ns
			-40°C to +85°C			225	ns
			-40°C to +125°C			235	ns
$t_{BBM}$	Break-before-make time delay (TMUX7213 Only)	$V_S = 10\text{ V}$ , $R_L = 300\ \Omega$ , $C_L = 35\text{ pF}$	25°C		28		ns
			-40°C to +85°C		10		ns
			-40°C to +125°C		10		ns
$t_{ON(VDD)}$	Device turn on time ( $V_{DD}$ to output)	$V_{DD}$ rise time = 1 $\mu\text{s}$ $R_L = 300\ \Omega$ , $C_L = 35\text{ pF}$ Refer to <a href="#">Turn-on (VDD) Time</a>	25°C		0.17		ms
			-40°C to +85°C			0.18	ms
			-40°C to +125°C			0.18	ms
$t_{PD}$	Propagation delay	$R_L = 50\ \Omega$ , $C_L = 5\text{ pF}$ Refer to <a href="#">Propagation Delay</a>	25°C		260		ps
$Q_{INJ}$	Charge injection	$V_S = 0\text{ V}$ , $C_L = 100\text{ pF}$ Refer to <a href="#">Charge Injection</a>	25°C		92		pC
$O_{ISO}$	Off-isolation	$R_L = 50\ \Omega$ , $C_L = 5\text{ pF}$ $V_S = 0\text{ V}$ , $f = 100\text{ kHz}$ Refer to <a href="#">Off Isolation</a>	25°C		-70		dB
$O_{ISO}$	Off-isolation	$R_L = 50\ \Omega$ , $C_L = 5\text{ pF}$ $V_S = 0\text{ V}$ , $f = 1\text{ MHz}$ Refer to <a href="#">Off Isolation</a>	25°C		-50		dB
$X_{TALK}$	Crosstalk	$R_L = 50\ \Omega$ , $C_L = 5\text{ pF}$ $V_S = 0\text{ V}$ , $f = 100\text{ kHz}$ Refer to <a href="#">Crosstalk</a>	25°C		-112		dB
$X_{TALK}$	Crosstalk	$R_L = 50\ \Omega$ , $C_L = 5\text{ pF}$ $V_S = 0\text{ V}$ , $f = 1\text{ MHz}$ Refer to <a href="#">Crosstalk</a>	25°C		-93		dB
BW	-3dB Bandwidth	$R_L = 50\ \Omega$ , $C_L = 5\text{ pF}$ $V_S = 0\text{ V}$ Refer to <a href="#">Bandwidth</a>	25°C		48		MHz
$I_L$	Insertion loss	$R_L = 50\ \Omega$ , $C_L = 5\text{ pF}$ $V_S = 0\text{ V}$ , $f = 1\text{ MHz}$	25°C		-0.14		dB
ACPSRR	AC Power Supply Rejection Ratio	$V_{PP} = 0.62\text{ V}$ on $V_{DD}$ and $V_{SS}$ $R_L = 50\ \Omega$ , $C_L = 5\text{ pF}$ , $f = 1\text{ MHz}$ Refer to <a href="#">ACPSRR</a>	25°C		-68		dB
THD+N	Total Harmonic Distortion + Noise	$V_{PP} = 20\text{ V}$ , $V_{BIAS} = 0\text{ V}$ $R_L = 10\text{ k}\Omega$ , $C_L = 5\text{ pF}$ , $f = 20\text{ Hz}$ to $20\text{ kHz}$ Refer to <a href="#">THD + Noise</a>	25°C		0.0003		%
$C_{S(OFF)}$	Source off capacitance	$V_S = 0\text{ V}$ , $f = 1\text{ MHz}$	25°C		28		pF
$C_{D(OFF)}$	Drain off capacitance	$V_S = 0\text{ V}$ , $f = 1\text{ MHz}$	25°C		45		pF
$C_{S(ON)}$ , $C_{D(ON)}$	On capacitance	$V_S = 0\text{ V}$ , $f = 1\text{ MHz}$	25°C		145		pF

## 6.10 44 V Single Supply: Electrical Characteristics

$V_{DD} = +44\text{ V}$ ,  $V_{SS} = 0\text{ V}$ ,  $GND = 0\text{ V}$  (unless otherwise noted)  
Typical at  $V_{DD} = +44\text{ V}$ ,  $V_{SS} = 0\text{ V}$ ,  $T_A = 25^\circ\text{C}$  (unless otherwise noted)

PARAMETER		TEST CONDITIONS	$T_A$	MIN	TYP	MAX	UNIT
<b>ANALOG SWITCH</b>							
$R_{ON}$	On-resistance	$V_S = 0\text{ V to }40\text{ V}$ $I_D = -10\text{ mA}$ Refer to <a href="#">On-Resistance</a>	25°C		2	2.4	$\Omega$
			-40°C to +85°C			3.2	$\Omega$
			-40°C to +125°C			3.8	$\Omega$
$\Delta R_{ON}$	On-resistance mismatch between channels	$V_S = 0\text{ V to }40\text{ V}$ $I_D = -10\text{ mA}$ Refer to <a href="#">On-Resistance</a>	25°C		0.1	0.18	$\Omega$
			-40°C to +85°C			0.19	$\Omega$
			-40°C to +125°C			0.21	$\Omega$
$R_{ON\text{ FLAT}}$	On-resistance flatness	$V_S = 0\text{ V to }40\text{ V}$ $I_D = -10\text{ mA}$ Refer to <a href="#">On-Resistance</a>	25°C		0.65	0.8	$\Omega$
			-40°C to +85°C			1.1	$\Omega$
			-40°C to +125°C			1.2	$\Omega$
$R_{ON\text{ DRIFT}}$	On-resistance drift	$V_S = 22\text{ V}$ , $I_S = -10\text{ mA}$ Refer to <a href="#">On-Resistance</a>	-40°C to +125°C		0.007		$\Omega/^\circ\text{C}$
$I_{S(OFF)}$	Source off leakage current <sup>(1)</sup>	$V_{DD} = 44\text{ V}$ , $V_{SS} = 0\text{ V}$ Switch state is off $V_S = 40\text{ V} / 1\text{ V}$ $V_D = 1\text{ V} / 40\text{ V}$ Refer to <a href="#">Off-Leakage Current</a>	25°C	-1	0.05	1	nA
			-40°C to +85°C			7	nA
			-40°C to +125°C			50	nA
$I_{D(OFF)}$	Drain off leakage current <sup>(1)</sup>	$V_{DD} = 44\text{ V}$ , $V_{SS} = 0\text{ V}$ Switch state is off $V_S = 40\text{ V} / 1\text{ V}$ $V_D = 1\text{ V} / 40\text{ V}$ Refer to <a href="#">Off-Leakage Current</a>	25°C	-1	0.05	1	nA
			-40°C to +85°C			7	nA
			-40°C to +125°C			50	nA
$I_{S(ON)}$ $I_{D(ON)}$	Channel on leakage current <sup>(2)</sup>	$V_{DD} = 44\text{ V}$ , $V_{SS} = 0\text{ V}$ Switch state is on $V_S = V_D = 40\text{ V or }1\text{ V}$ Refer to <a href="#">On-Leakage Current</a>	25°C	-1	0.05	1	nA
			-40°C to +85°C			3.5	nA
			-40°C to +125°C			5	nA
<b>LOGIC INPUTS (SEL / EN pins)</b>							
$V_{IH}$	Logic voltage high		-40°C to +125°C	1.3		44	V
$V_{IL}$	Logic voltage low		-40°C to +125°C	0		0.8	V
$I_{IH}$	Input leakage current		-40°C to +125°C		0.6	2	$\mu\text{A}$
$I_{IL}$	Input leakage current		-40°C to +125°C	-0.1	-0.005		$\mu\text{A}$
$C_{IN}$	Logic input capacitance		-40°C to +125°C		3.5		pF
<b>POWER SUPPLY</b>							
$I_{DD}$	$V_{DD}$ supply current	$V_{DD} = 44\text{ V}$ , $V_{SS} = 0\text{ V}$ Logic inputs = 0 V, 5 V, or $V_{DD}$	25°C		44	79	$\mu\text{A}$
			-40°C to +85°C			88	$\mu\text{A}$
			-40°C to +125°C			105	$\mu\text{A}$

(1) When  $V_S$  is positive,  $V_D$  is negative, or when  $V_S$  is negative,  $V_D$  is positive.

(2) When  $V_S$  is at a voltage potential,  $V_D$  is floating, or when  $V_D$  is at a voltage potential,  $V_S$  is floating.

## 6.11 44 V Single Supply: Switching Characteristics

$V_{DD} = +44\text{ V}$ ,  $V_{SS} = 0\text{ V}$ ,  $GND = 0\text{ V}$  (unless otherwise noted)  
 Typical at  $V_{DD} = +44\text{ V}$ ,  $V_{SS} = 0\text{ V}$ ,  $T_A = 25^\circ\text{C}$  (unless otherwise noted)

PARAMETER		TEST CONDITIONS	$T_A$	MIN	TYP	MAX	UNIT
$t_{ON}$	Turn-on time from control input	$V_S = 18\text{ V}$ $R_L = 300\ \Omega$ , $C_L = 35\text{ pF}$ Refer to <a href="#">Turn-on and Turn-off Time</a>	$25^\circ\text{C}$		80	185	ns
			$-40^\circ\text{C to }+85^\circ\text{C}$			205	ns
			$-40^\circ\text{C to }+125^\circ\text{C}$			225	ns
$t_{OFF}$	Turn-off time from control input	$V_S = 18\text{ V}$ $R_L = 300\ \Omega$ , $C_L = 35\text{ pF}$ Refer to <a href="#">Turn-on and Turn-off Time</a>	$25^\circ\text{C}$		90	205	ns
			$-40^\circ\text{C to }+85^\circ\text{C}$			220	ns
			$-40^\circ\text{C to }+125^\circ\text{C}$			228	ns
$t_{BBM}$	Break-before-make time delay (TMUX7213 Only)	$V_S = 18\text{ V}$ , $R_L = 300\ \Omega$ , $C_L = 35\text{ pF}$	$25^\circ\text{C}$		27		ns
			$-40^\circ\text{C to }+85^\circ\text{C}$		10		ns
			$-40^\circ\text{C to }+125^\circ\text{C}$		10		ns
$t_{ON(VDD)}$	Device turn on time ( $V_{DD}$ to output)	$V_{DD}$ rise time = $1\ \mu\text{s}$ $R_L = 300\ \Omega$ , $C_L = 35\text{ pF}$ Refer to <a href="#">Turn-on (VDD) Time</a>	$25^\circ\text{C}$		0.14		ms
			$-40^\circ\text{C to }+85^\circ\text{C}$			0.15	ms
			$-40^\circ\text{C to }+125^\circ\text{C}$			0.15	ms
$t_{PD}$	Propagation delay	$R_L = 50\ \Omega$ , $C_L = 5\text{ pF}$ Refer to <a href="#">Propagation Delay</a>	$25^\circ\text{C}$		270		ps
$Q_{INJ}$	Charge injection	$V_S = 22\text{ V}$ , $C_L = 100\text{ pF}$ Refer to <a href="#">Charge Injection</a>	$25^\circ\text{C}$		104		pC
$O_{ISO}$	Off-isolation	$R_L = 50\ \Omega$ , $C_L = 5\text{ pF}$ $V_S = 6\text{ V}$ , $f = 100\text{ kHz}$ Refer to <a href="#">Off Isolation</a>	$25^\circ\text{C}$		-70		dB
$O_{ISO}$	Off-isolation	$R_L = 50\ \Omega$ , $C_L = 5\text{ pF}$ $V_S = 6\text{ V}$ , $f = 1\text{ MHz}$ Refer to <a href="#">Off Isolation</a>	$25^\circ\text{C}$		-50		dB
$X_{TALK}$	Crosstalk	$R_L = 50\ \Omega$ , $C_L = 5\text{ pF}$ $V_S = 6\text{ V}$ , $f = 100\text{ kHz}$ Refer to <a href="#">Crosstalk</a>	$25^\circ\text{C}$		-112		dB
$X_{TALK}$	Crosstalk	$R_L = 50\ \Omega$ , $C_L = 5\text{ pF}$ $V_S = 6\text{ V}$ , $f = 1\text{ MHz}$ Refer to <a href="#">Crosstalk</a>	$25^\circ\text{C}$		-93		dB
BW	-3dB Bandwidth	$R_L = 50\ \Omega$ , $C_L = 5\text{ pF}$ $V_S = 6\text{ V}$ Refer to <a href="#">Bandwidth</a>	$25^\circ\text{C}$		46		MHz
$I_L$	Insertion loss	$R_L = 50\ \Omega$ , $C_L = 5\text{ pF}$ $V_S = 6\text{ V}$ , $f = 1\text{ MHz}$	$25^\circ\text{C}$		-0.15		dB
ACPSRR	AC Power Supply Rejection Ratio	$V_{PP} = 0.62\text{ V}$ on $V_{DD}$ and $V_{SS}$ $R_L = 50\ \Omega$ , $C_L = 5\text{ pF}$ , $f = 1\text{ MHz}$ Refer to <a href="#">ACPSRR</a>	$25^\circ\text{C}$		-66		dB
THD+N	Total Harmonic Distortion + Noise	$V_{PP} = 22\text{ V}$ , $V_{BIAS} = 22\text{ V}$ $R_L = 10\text{ k}\Omega$ , $C_L = 5\text{ pF}$ , $f = 20\text{ Hz to }20\text{ kHz}$ Refer to <a href="#">THD + Noise</a>	$25^\circ\text{C}$		0.0003		%
$C_{S(OFF)}$	Source off capacitance	$V_S = 22\text{ V}$ , $f = 1\text{ MHz}$	$25^\circ\text{C}$		28		pF
$C_{D(OFF)}$	Drain off capacitance	$V_S = 22\text{ V}$ , $f = 1\text{ MHz}$	$25^\circ\text{C}$		45		pF
$C_{S(ON)}$ , $C_{D(ON)}$	On capacitance	$V_S = 22\text{ V}$ , $f = 1\text{ MHz}$	$25^\circ\text{C}$		145		pF

## 6.12 12 V Single Supply: Electrical Characteristics

$V_{DD} = +12\text{ V} \pm 10\%$ ,  $V_{SS} = 0\text{ V}$ ,  $GND = 0\text{ V}$  (unless otherwise noted)

Typical at  $V_{DD} = +12\text{ V}$ ,  $V_{SS} = 0\text{ V}$ ,  $T_A = 25^\circ\text{C}$  (unless otherwise noted)

PARAMETER		TEST CONDITIONS	$T_A$	MIN	TYP	MAX	UNIT	
<b>ANALOG SWITCH</b>								
$R_{ON}$	On-resistance	$V_S = 0\text{ V to }10\text{ V}$ $I_D = -10\text{ mA}$ Refer to <a href="#">On-Resistance</a>	25°C	2.8	5.4		$\Omega$	
			-40°C to +85°C			6.8	$\Omega$	
			-40°C to +125°C			7.4	$\Omega$	
$\Delta R_{ON}$	On-resistance mismatch between channels	$V_S = 0\text{ V to }10\text{ V}$ $I_D = -10\text{ mA}$ Refer to <a href="#">On-Resistance</a>	25°C	0.13	0.21		$\Omega$	
			-40°C to +85°C			0.23	$\Omega$	
			-40°C to +125°C			0.25	$\Omega$	
$R_{ON\text{ FLAT}}$	On-resistance flatness	$V_S = 0\text{ V to }10\text{ V}$ $I_S = -10\text{ mA}$ Refer to <a href="#">On-Resistance</a>	25°C	1	1.7		$\Omega$	
			-40°C to +85°C			1.9	$\Omega$	
			-40°C to +125°C			2	$\Omega$	
$R_{ON\text{ DRIFT}}$	On-resistance drift	$V_S = 6\text{ V}$ , $I_S = -10\text{ mA}$ Refer to <a href="#">On-Resistance</a>	-40°C to +125°C	0.015			$\Omega/^\circ\text{C}$	
$I_{S(OFF)}$	Source off leakage current <sup>(1)</sup>	$V_{DD} = 13.2\text{ V}$ , $V_{SS} = 0\text{ V}$ Switch state is off $V_S = 10\text{ V} / 1\text{ V}$ $V_D = 1\text{ V} / 10\text{ V}$ Refer to <a href="#">Off-Leakage Current</a>	25°C	-0.25	0.01	0.25	nA	
			-40°C to +85°C		-2		2	nA
			-40°C to +125°C		-16		16	nA
$I_{D(OFF)}$	Drain off leakage current <sup>(1)</sup>	$V_{DD} = 13.2\text{ V}$ , $V_{SS} = 0\text{ V}$ Switch state is off $V_S = 10\text{ V} / 1\text{ V}$ $V_D = 1\text{ V} / 10\text{ V}$ Refer to <a href="#">Off-Leakage Current</a>	25°C	-0.25	0.05	0.25	nA	
			-40°C to +85°C		-2		2	nA
			-40°C to +125°C		-16		16	nA
$I_{S(ON)}$ $I_{D(ON)}$	Channel on leakage current <sup>(2)</sup>	$V_{DD} = 13.2\text{ V}$ , $V_{SS} = 0\text{ V}$ Switch state is on $V_S = V_D = 10\text{ V}$ or $1\text{ V}$ Refer to <a href="#">On-Leakage Current</a>	25°C	-0.5	0.05	0.5	nA	
			-40°C to +85°C		-1		1	nA
			-40°C to +125°C		-3		3	nA
<b>LOGIC INPUTS (SEL / EN pins)</b>								
$V_{IH}$	Logic voltage high		-40°C to +125°C	1.3		44	V	
$V_{IL}$	Logic voltage low		-40°C to +125°C	0		0.8	V	
$I_{IH}$	Input leakage current		-40°C to +125°C		0.4	2	$\mu\text{A}$	
$I_{IL}$	Input leakage current		-40°C to +125°C	-0.1	-0.005		$\mu\text{A}$	
$C_{IN}$	Logic input capacitance		-40°C to +125°C		3.5		pF	
<b>POWER SUPPLY</b>								
$I_{DD}$	$V_{DD}$ supply current	$V_{DD} = 13.2\text{ V}$ , $V_{SS} = 0\text{ V}$ Logic inputs = $0\text{ V}$ , $5\text{ V}$ , or $V_{DD}$	25°C	30	44		$\mu\text{A}$	
			-40°C to +85°C			52	$\mu\text{A}$	
			-40°C to +125°C			62	$\mu\text{A}$	

(1) When  $V_S$  is positive,  $V_D$  is negative, or when  $V_S$  is negative,  $V_D$  is positive.

(2) When  $V_S$  is at a voltage potential,  $V_D$  is floating, or when  $V_D$  is at a voltage potential,  $V_S$  is floating.

### 6.13 12 V Single Supply: Switching Characteristics

$V_{DD} = +12\text{ V} \pm 10\%$ ,  $V_{SS} = 0\text{ V}$ ,  $GND = 0\text{ V}$  (unless otherwise noted)

Typical at  $V_{DD} = +12\text{ V}$ ,  $V_{SS} = 0\text{ V}$ ,  $T_A = 25^\circ\text{C}$  (unless otherwise noted)

PARAMETER		TEST CONDITIONS	$T_A$	MIN	TYP	MAX	UNIT
$t_{ON}$	Turn-on time from control input	$V_S = 8\text{ V}$ $R_L = 300\ \Omega$ , $C_L = 35\text{ pF}$ Refer to <a href="#">Turn-on and Turn-off Time</a>	$25^\circ\text{C}$		170	225	ns
			$-40^\circ\text{C}$ to $+85^\circ\text{C}$			276	ns
			$-40^\circ\text{C}$ to $+125^\circ\text{C}$			315	ns
$t_{OFF}$	Turn-off time from control input	$V_S = 8\text{ V}$ $R_L = 300\ \Omega$ , $C_L = 35\text{ pF}$ Refer to <a href="#">Turn-on and Turn-off Time</a>	$25^\circ\text{C}$		75	248	ns
			$-40^\circ\text{C}$ to $+85^\circ\text{C}$			285	ns
			$-40^\circ\text{C}$ to $+125^\circ\text{C}$			310	ns
$t_{BBM}$	Break-before-make time delay (TMUX7213 Only)	$V_S = 8\text{ V}$ , $R_L = 300\ \Omega$ , $C_L = 35\text{ pF}$	$25^\circ\text{C}$		30		ns
			$-40^\circ\text{C}$ to $+85^\circ\text{C}$		13		ns
			$-40^\circ\text{C}$ to $+125^\circ\text{C}$		13		ns
$t_{ON(VDD)}$	Device turn on time ( $V_{DD}$ to output)	$V_{DD}$ rise time = $1\ \mu\text{s}$ $R_L = 300\ \Omega$ , $C_L = 35\text{ pF}$ Refer to <a href="#">Turn-on (VDD) Time</a>	$25^\circ\text{C}$		0.17		ms
			$-40^\circ\text{C}$ to $+85^\circ\text{C}$			0.18	ms
			$-40^\circ\text{C}$ to $+125^\circ\text{C}$			0.18	ms
$t_{PD}$	Propagation delay	$R_L = 50\ \Omega$ , $C_L = 5\text{ pF}$ Refer to <a href="#">Propagation Delay</a>	$25^\circ\text{C}$		270		ps
$Q_{INJ}$	Charge injection	$V_S = 6\text{ V}$ , $C_L = 100\text{ pF}$ Refer to <a href="#">Charge Injection</a>	$25^\circ\text{C}$		12		pC
$O_{ISO}$	Off-isolation	$R_L = 50\ \Omega$ , $C_L = 5\text{ pF}$ $V_S = 6\text{ V}$ , $f = 100\text{ kHz}$ Refer to <a href="#">Off Isolation</a>	$25^\circ\text{C}$		-70		dB
$O_{ISO}$	Off-isolation	$R_L = 50\ \Omega$ , $C_L = 5\text{ pF}$ $V_S = 6\text{ V}$ , $f = 1\text{ MHz}$ Refer to <a href="#">Off Isolation</a>	$25^\circ\text{C}$		-50		dB
$X_{TALK}$	Crosstalk	$R_L = 50\ \Omega$ , $C_L = 5\text{ pF}$ $V_S = 6\text{ V}$ , $f = 100\text{ kHz}$ Refer to <a href="#">Crosstalk</a>	$25^\circ\text{C}$		-112		dB
$X_{TALK}$	Crosstalk	$R_L = 50\ \Omega$ , $C_L = 5\text{ pF}$ $V_S = 6\text{ V}$ , $f = 1\text{ MHz}$ Refer to <a href="#">Crosstalk</a>	$25^\circ\text{C}$		-93		dB
BW	-3dB Bandwidth	$R_L = 50\ \Omega$ , $C_L = 5\text{ pF}$ $V_S = 6\text{ V}$ Refer to <a href="#">Bandwidth</a>	$25^\circ\text{C}$		125		MHz
$I_L$	Insertion loss	$R_L = 50\ \Omega$ , $C_L = 5\text{ pF}$ $V_S = 6\text{ V}$ , $f = 1\text{ MHz}$	$25^\circ\text{C}$		-0.25		dB
ACPSRR	AC Power Supply Rejection Ratio	$V_{PP} = 0.62\text{ V}$ on $V_{DD}$ and $V_{SS}$ $R_L = 50\ \Omega$ , $C_L = 5\text{ pF}$ , $f = 1\text{ MHz}$ Refer to <a href="#">ACPSRR</a>	$25^\circ\text{C}$		-70		dB
THD+N	Total Harmonic Distortion + Noise	$V_{PP} = 6\text{ V}$ , $V_{BIAS} = 6\text{ V}$ $R_L = 10\text{ k}\Omega$ , $C_L = 5\text{ pF}$ , $f = 20\text{ Hz}$ to $20\text{ kHz}$ Refer to <a href="#">THD + Noise</a>	$25^\circ\text{C}$		0.001		%
$C_{S(OFF)}$	Source off capacitance	$V_S = 6\text{ V}$ , $f = 1\text{ MHz}$	$25^\circ\text{C}$		35		pF
$C_{D(OFF)}$	Drain off capacitance	$V_S = 6\text{ V}$ , $f = 1\text{ MHz}$	$25^\circ\text{C}$		50		pF
$C_{S(ON)}$ , $C_{D(ON)}$	On capacitance	$V_S = 6\text{ V}$ , $f = 1\text{ MHz}$	$25^\circ\text{C}$		145		pF

## 6.14 Typical Characteristics

at  $T_A = 25^\circ\text{C}$  (unless otherwise noted)

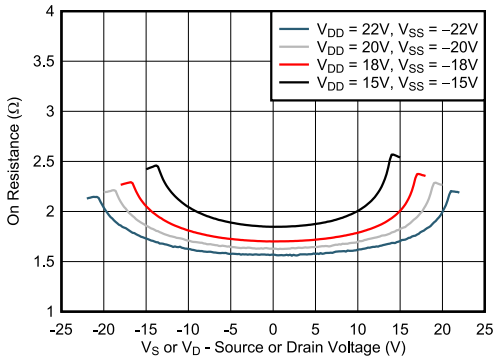

6-1. On-Resistance vs. Source or Drain Voltage – Dual Supply

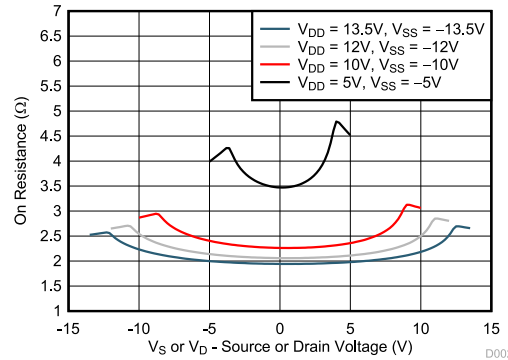

6-2. On-Resistance vs. Source or Drain Voltage – Dual Supply

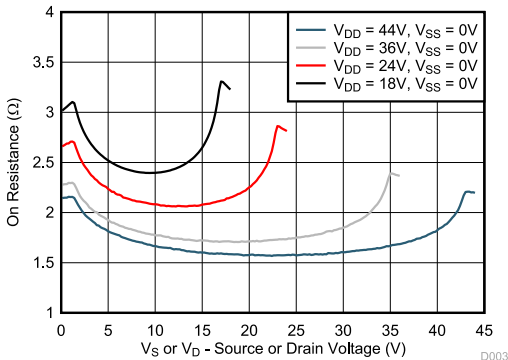

6-3. On-Resistance vs. Source or Drain Voltage – Single Supply

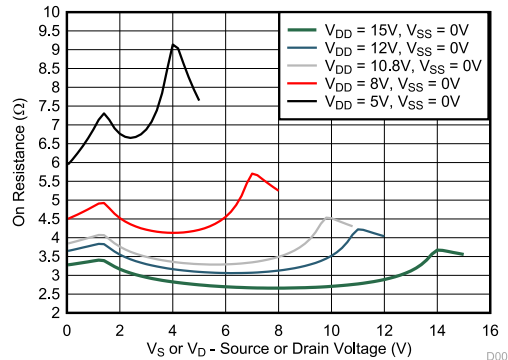

6-4. On-Resistance vs. Source or Drain Voltage – Single Supply

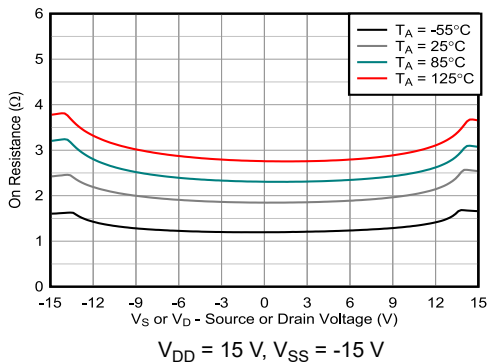

6-5. On-Resistance vs Temperature

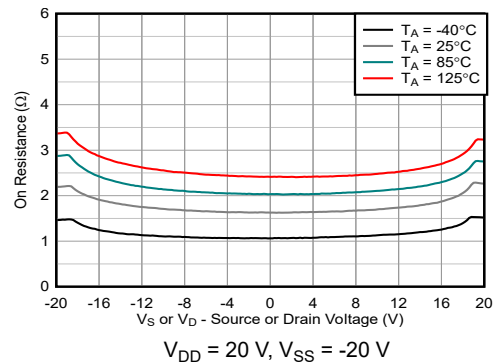

6-6. On-Resistance vs Temperature

## 6.14 Typical Characteristics (continued)

at  $T_A = 25^\circ\text{C}$  (unless otherwise noted)

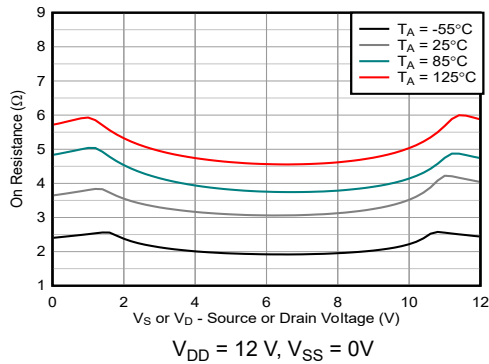

6-7. On-Resistance vs Temperature

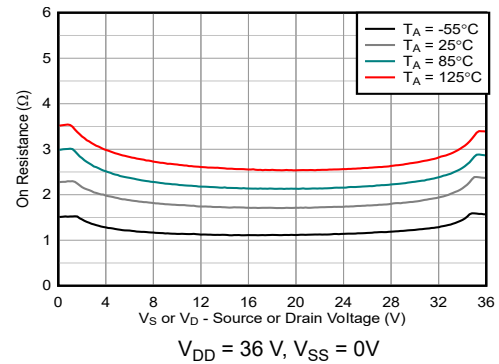

6-8. On-Resistance vs Temperature

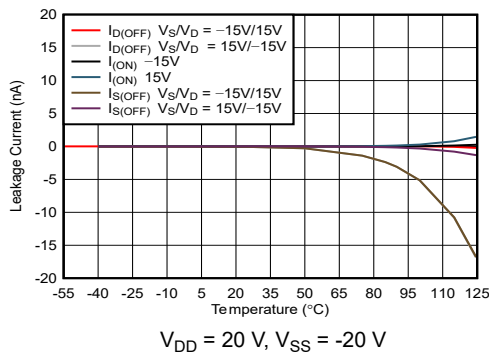

6-9. Leakage Current vs Temperature

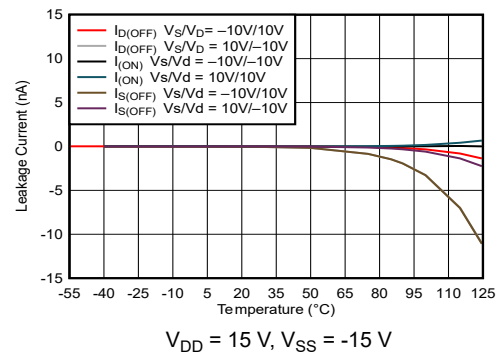

6-10. Leakage Current vs Temperature

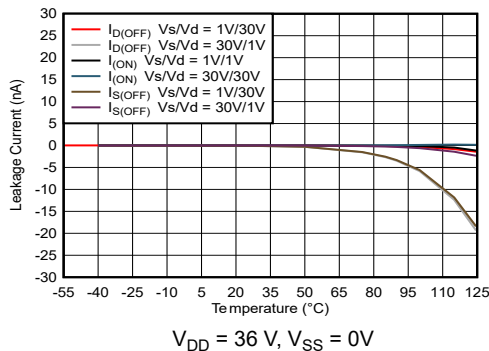

6-11. Leakage Current vs Temperature

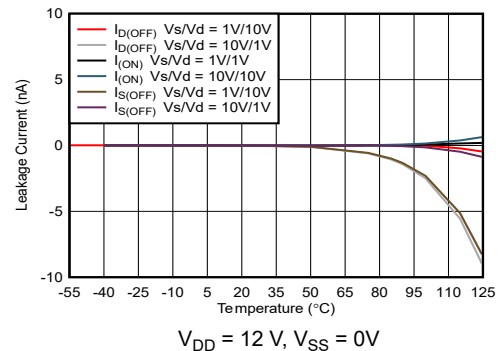

6-12. Leakage Current vs Temperature



## 6.14 Typical Characteristics (continued)

at  $T_A = 25^\circ\text{C}$  (unless otherwise noted)

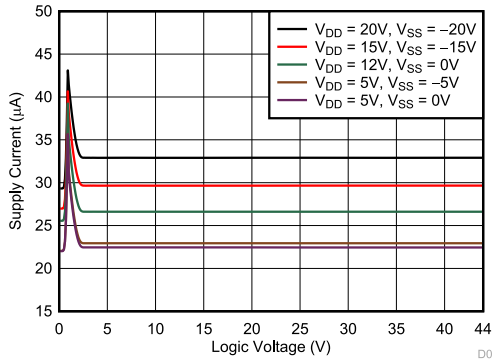

Figure 6-13. Supply Current vs. Logic Voltage

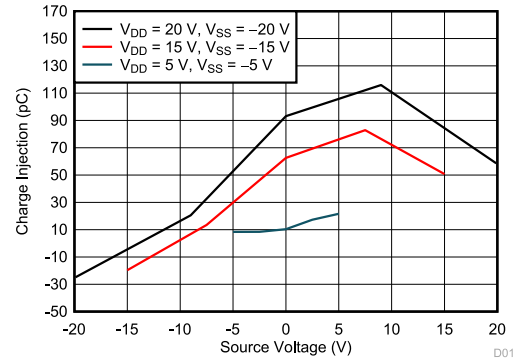

Figure 6-14. Charge Injection vs. Source Voltage – Dual Supply

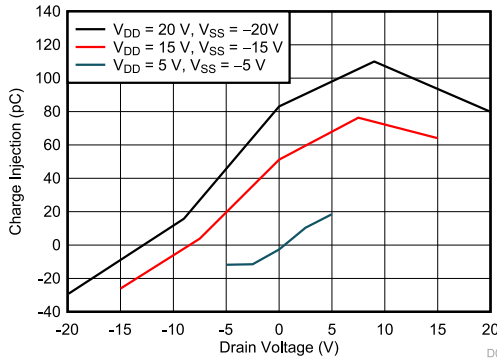

Figure 6-15. Charge Injection vs. Drain Voltage – Dual Supply

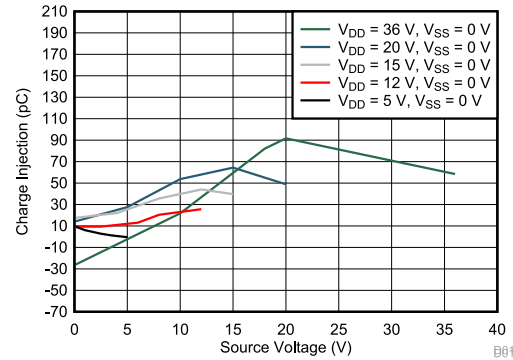

Figure 6-16. Charge Injection vs. Source Voltage – Single Supply

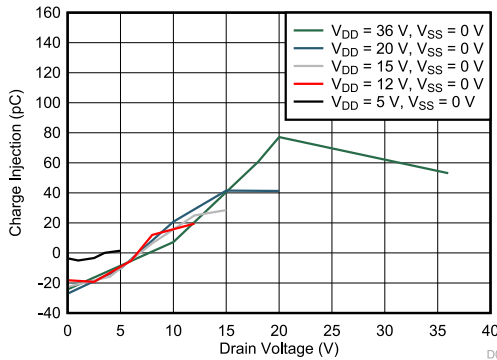

Figure 6-17. Charge Injection vs. Drain Voltage – Single Supply

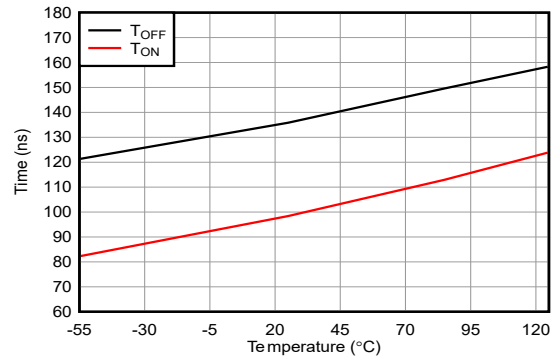
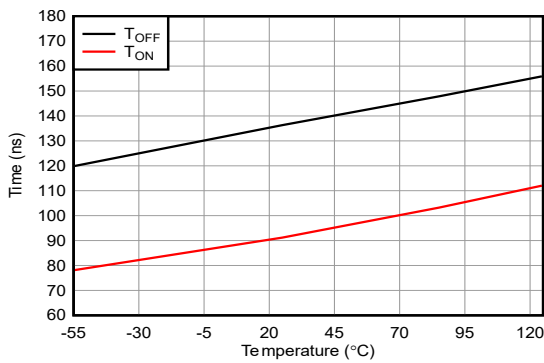

Figure 6-18.  $T_{ON}$  and  $T_{OFF}$  vs. Temperature

## 6.14 Typical Characteristics (continued)

at  $T_A = 25^\circ\text{C}$  (unless otherwise noted)



$V_{DD} = 36\text{ V}, V_{SS} = 0\text{ V}$

Figure 6-19.  $T_{ON}$  and  $T_{OFF}$  vs. Temperature

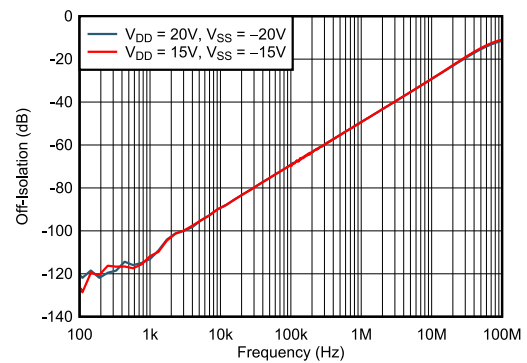

Figure 6-20. Off-Isolation vs Frequency

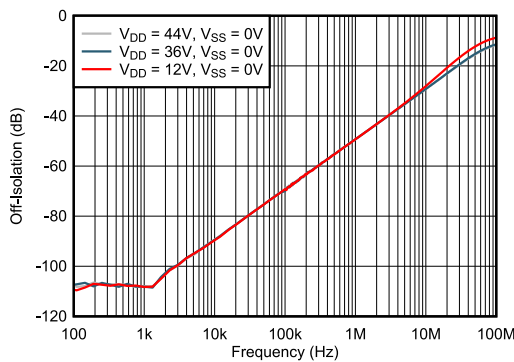
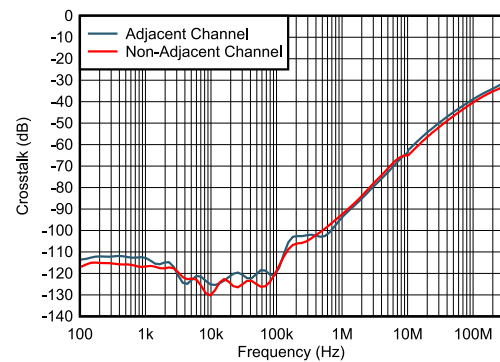

Figure 6-21. Off-Isolation vs Frequency



$V_{DD} = +15\text{ V}, V_{SS} = -15\text{ V}$

Figure 6-22. Crosstalk vs Frequency

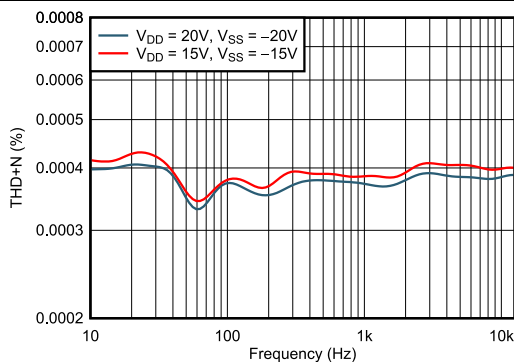

Figure 6-23. THD+N vs. Frequency (Dual Supplies)

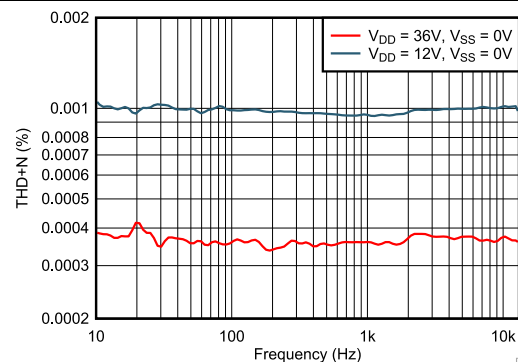

Figure 6-24. THD+N vs. Frequency (Single Supplies)

### 6.14 Typical Characteristics (continued)

at  $T_A = 25^\circ\text{C}$  (unless otherwise noted)



图 6-25. On Response vs Frequency



图 6-26. ACPSRR vs. Frequency

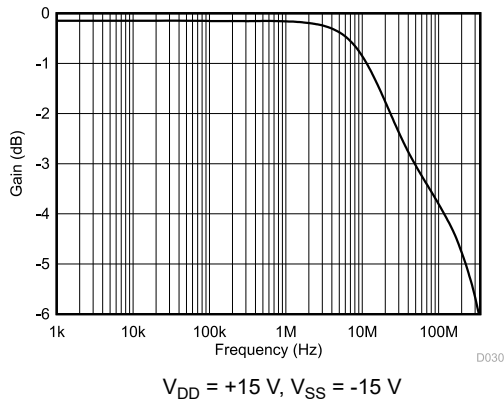

图 6-27. Capacitance vs. Source Voltage or Drain Voltage

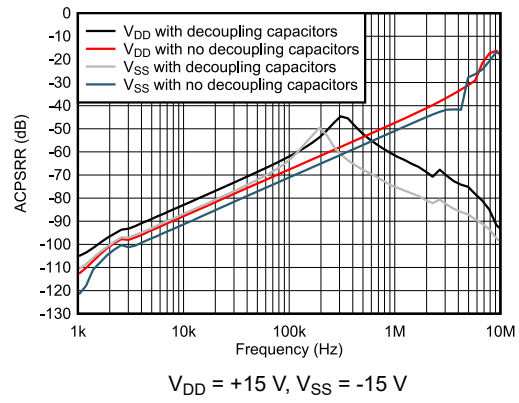

图 6-28. Capacitance vs. Source Voltage or Drain Voltage

## 7 Parameter Measurement Information

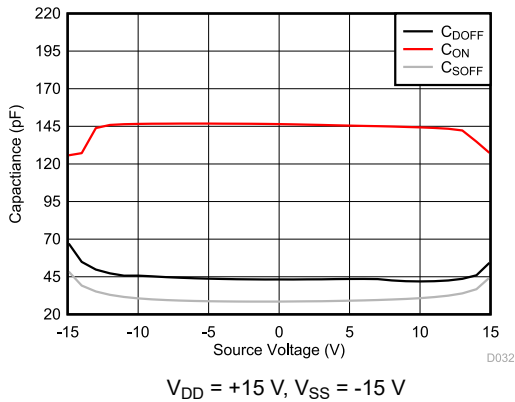
### 7.1 On-Resistance

The on-resistance of a device is the ohmic resistance between the source (Sx) and drain (Dx) pins of the device. The on-resistance varies with input voltage and supply voltage. The symbol  $R_{ON}$  is used to denote on-resistance.  shows the measurement setup used to measure  $R_{ON}$ . Voltage (V) and current ( $I_{SD}$ ) are measured using this setup, and  $R_{ON}$  is computed with  $R_{ON} = V / I_{SD}$ :

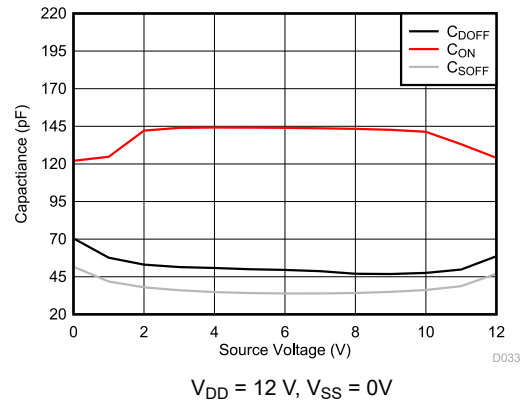
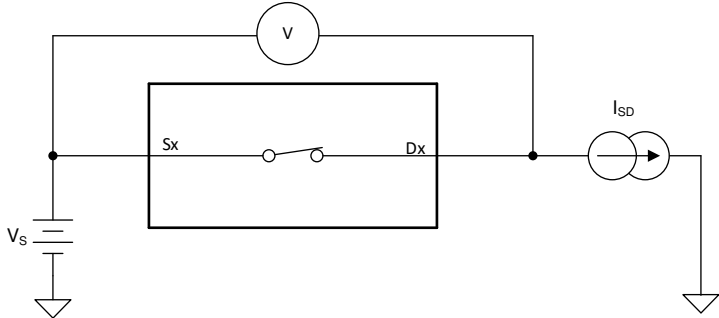
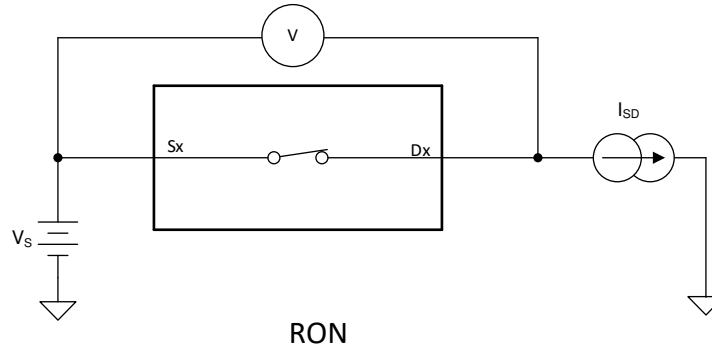

 7-1. On-Resistance Measurement Setup

### 7.2 Off-Leakage Current

There are two types of leakage currents associated with a switch during the off state:

1. Source off-leakage current.
2. Drain off-leakage current.

Source leakage current is defined as the leakage current flowing into or out of the source pin when the switch is off. This current is denoted by the symbol  $I_{S(OFF)}$ .

Drain leakage current is defined as the leakage current flowing into or out of the drain pin when the switch is off. This current is denoted by the symbol  $I_{D(OFF)}$ .

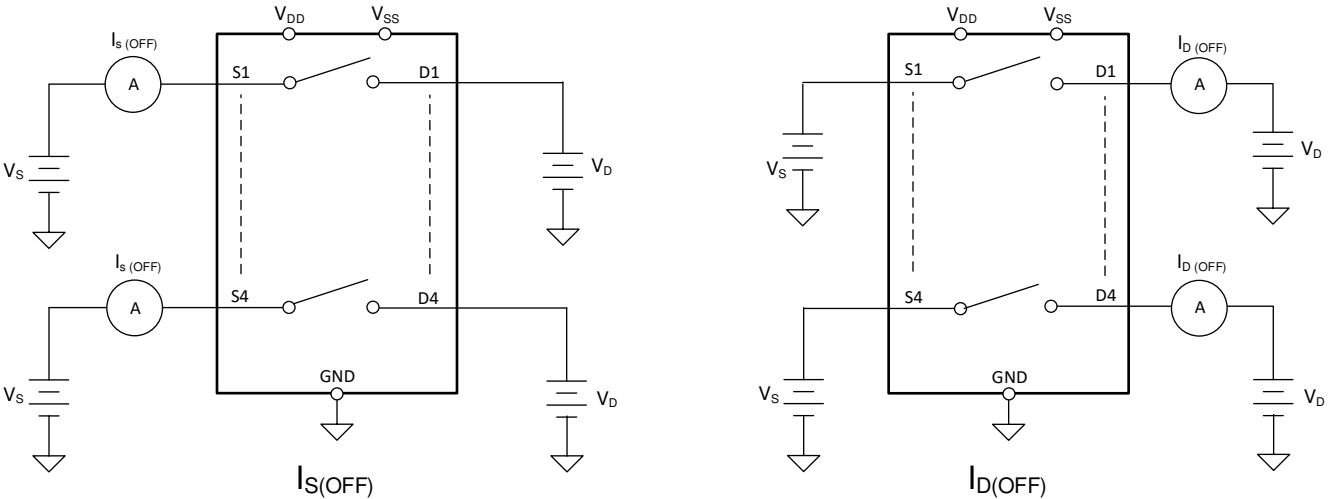
 shows the setup used to measure both off-leakage currents.

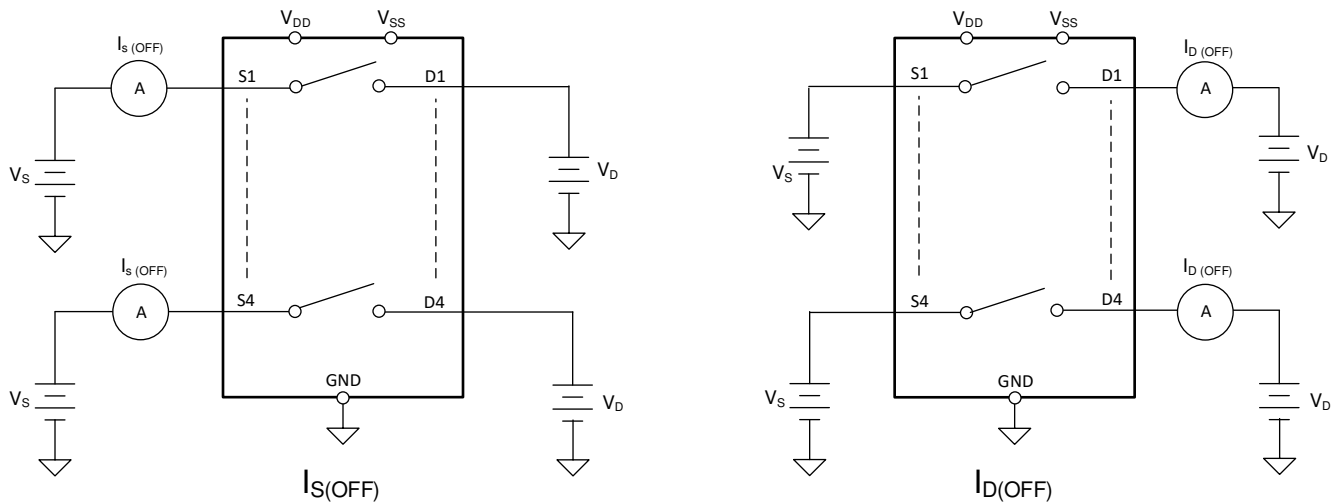

 7-2. Off-Leakage Measurement Setup

### 7.3 On-Leakage Current

Source on-leakage current is defined as the leakage current flowing into or out of the source pin when the switch is on. This current is denoted by the symbol  $I_{S(ON)}$ .

Drain on-leakage current is defined as the leakage current flowing into or out of the drain pin when the switch is on. This current is denoted by the symbol  $I_{D(ON)}$ .

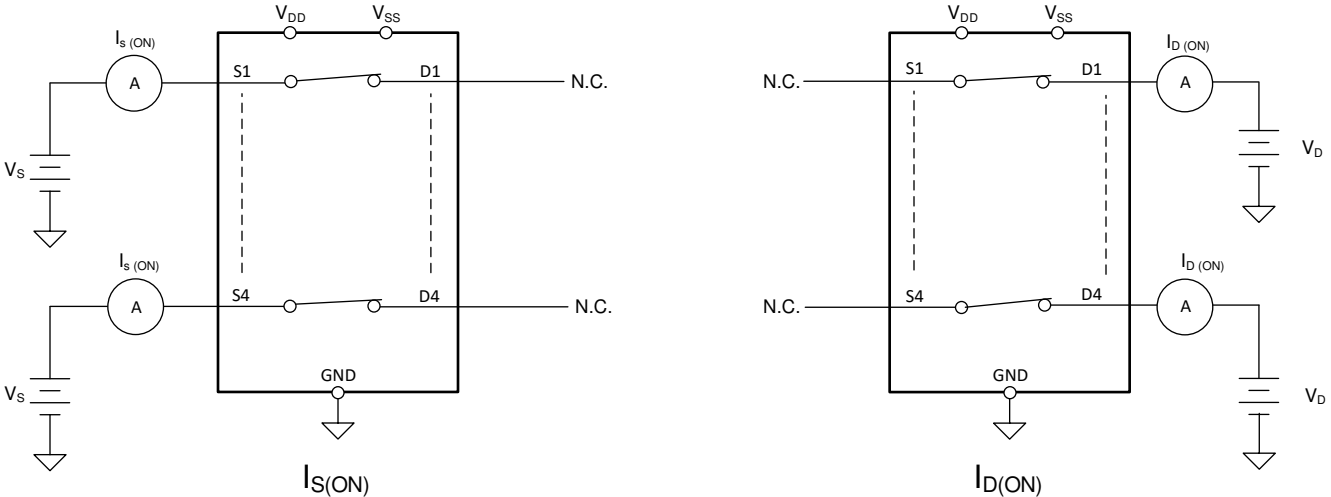
Either the source pin or drain pin is left floating during the measurement.  shows the circuit used for measuring the on-leakage current, denoted by  $I_{S(ON)}$  or  $I_{D(ON)}$ .

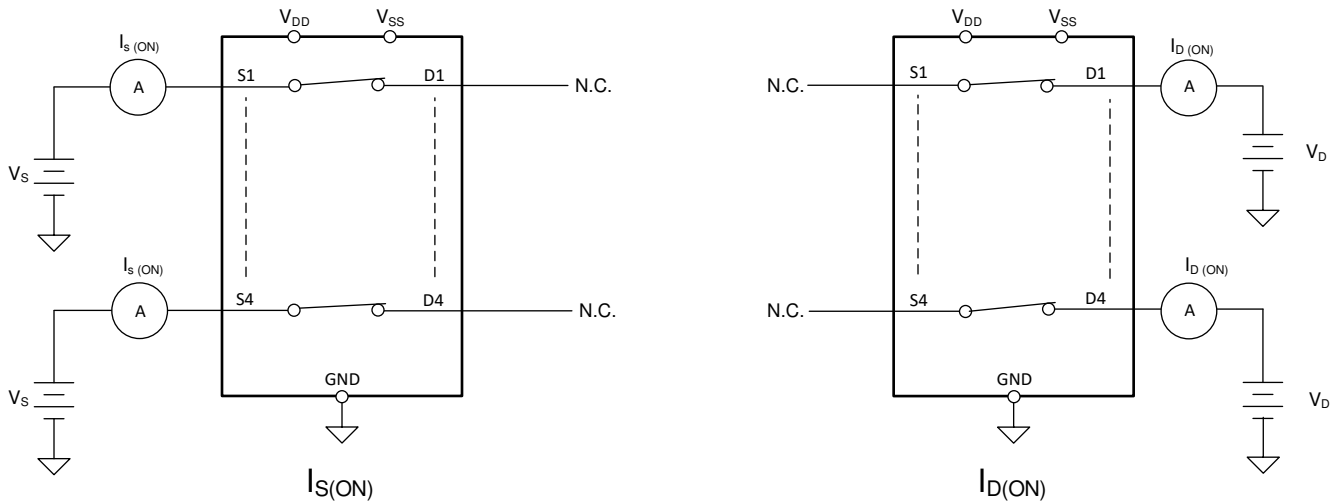

 7-3. On-Leakage Measurement Setup

### 7.4 $t_{ON}$ and $t_{OFF}$ Time

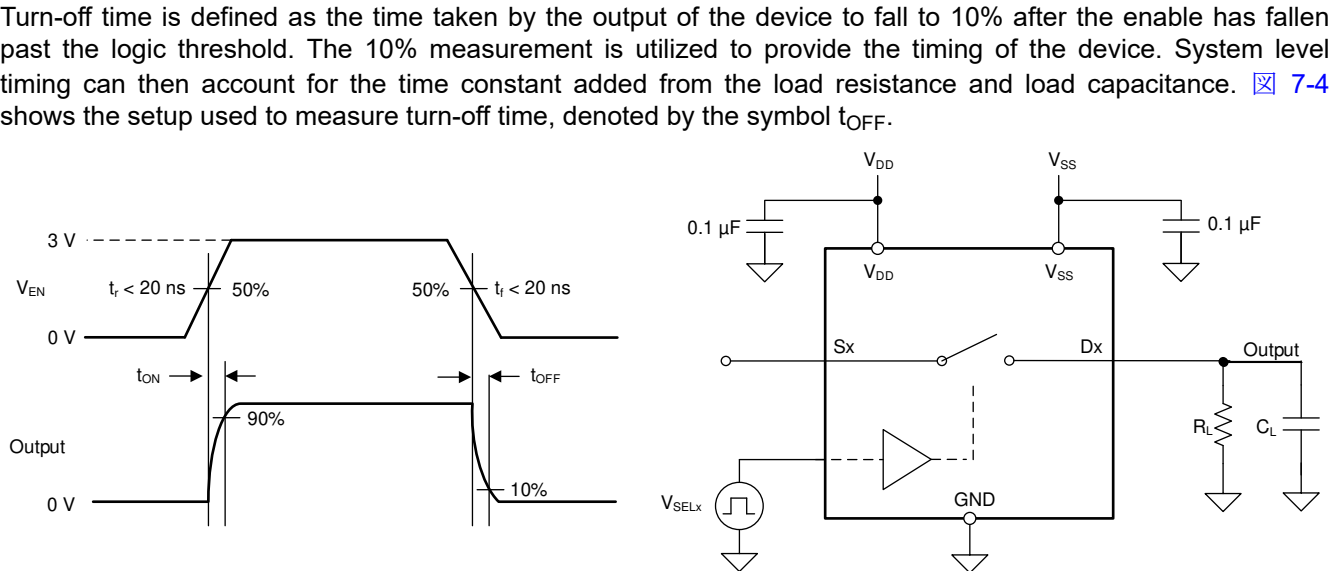
Turn-on time is defined as the time taken by the output of the device to rise to 90% after the enable has risen past the logic threshold. The 90% measurement is utilized to provide the timing of the device. System level timing can then account for the time constant added from the load resistance and load capacitance.  shows the setup used to measure turn-on time, denoted by the symbol  $t_{ON}$ .

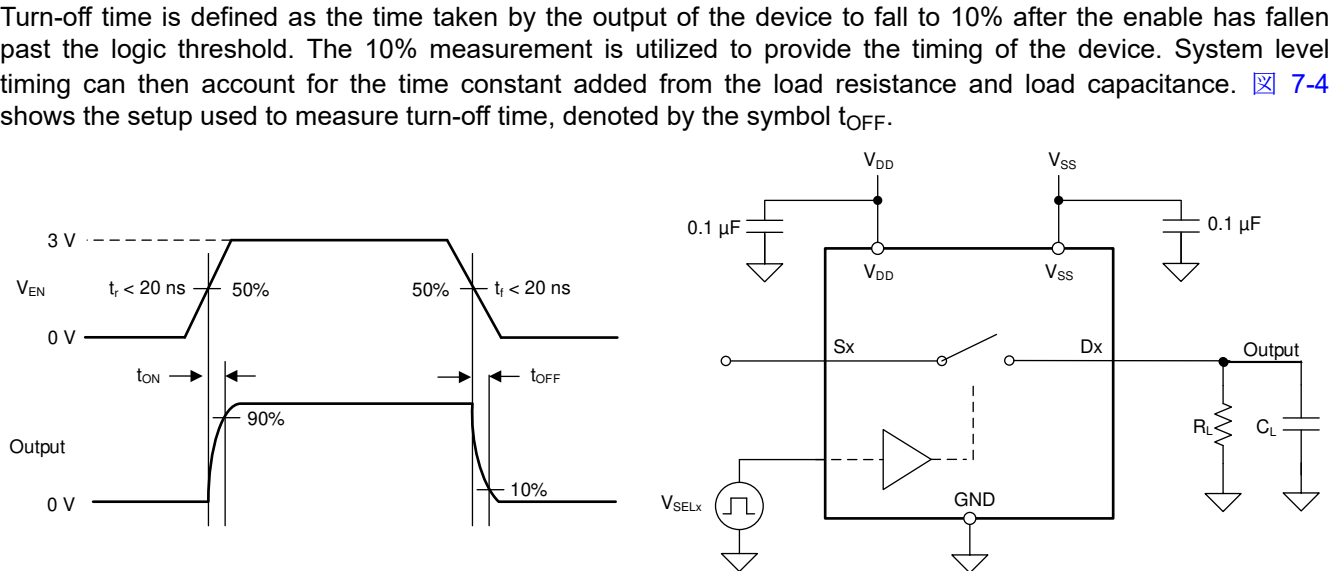
Turn-off time is defined as the time taken by the output of the device to fall to 10% after the enable has fallen past the logic threshold. The 10% measurement is utilized to provide the timing of the device. System level timing can then account for the time constant added from the load resistance and load capacitance.  shows the setup used to measure turn-off time, denoted by the symbol  $t_{OFF}$ .

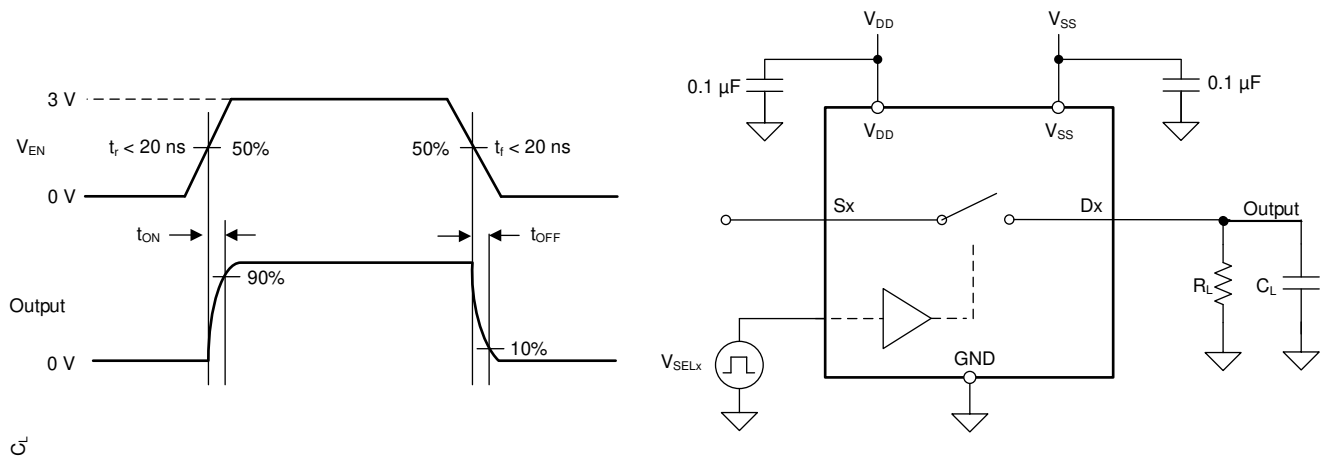

 7-4. Turn-On and Turn-Off Time Measurement Setup

## 7.5 $t_{ON(VDD)}$ Time

The  $t_{ON(VDD)}$  time is defined as the time taken by the output of the device to rise to 90% after the supply has risen past the supply threshold. The 90% measurement is used to provide the timing of the device turning on in the system.  7-5 shows the setup used to measure turn on time, denoted by the symbol  $t_{ON(VDD)}$ .

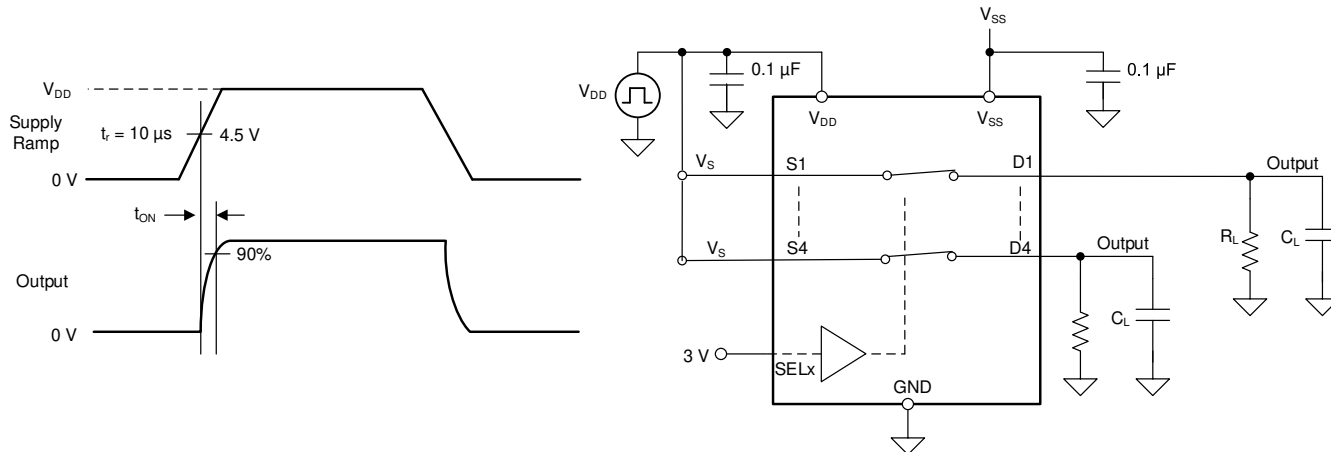

 7-5.  $t_{ON(VDD)}$  Time Measurement Setup

## 7.6 Propagation Delay

Propagation delay is defined as the time taken by the output of the device to rise or fall 50% after the input signal has risen or fallen past the 50% threshold.  7-6 shows the setup used to measure propagation delay, denoted by the symbol  $t_{PD}$ .

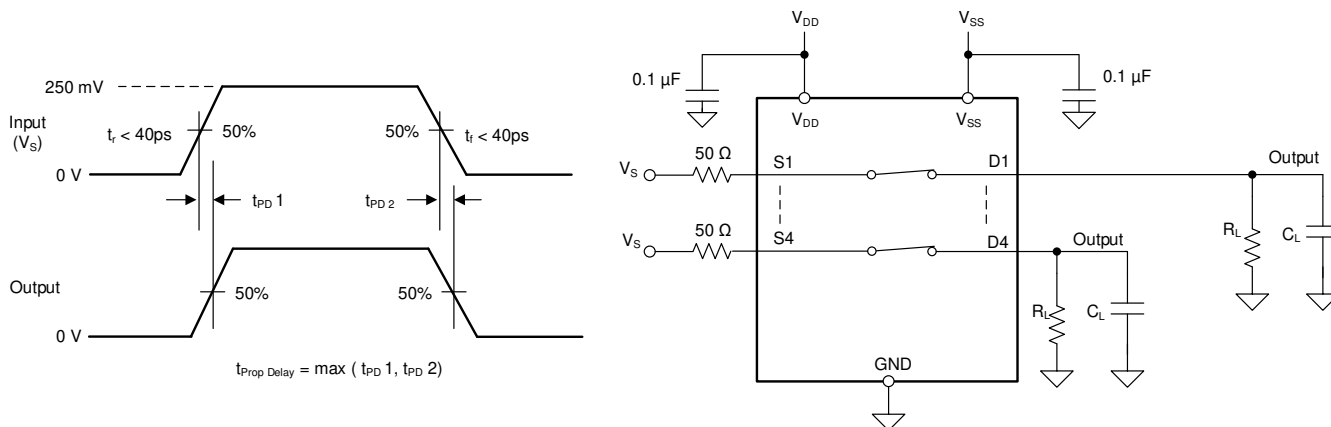

 7-6. Propagation Delay Measurement Setup

## 7.7 Charge Injection

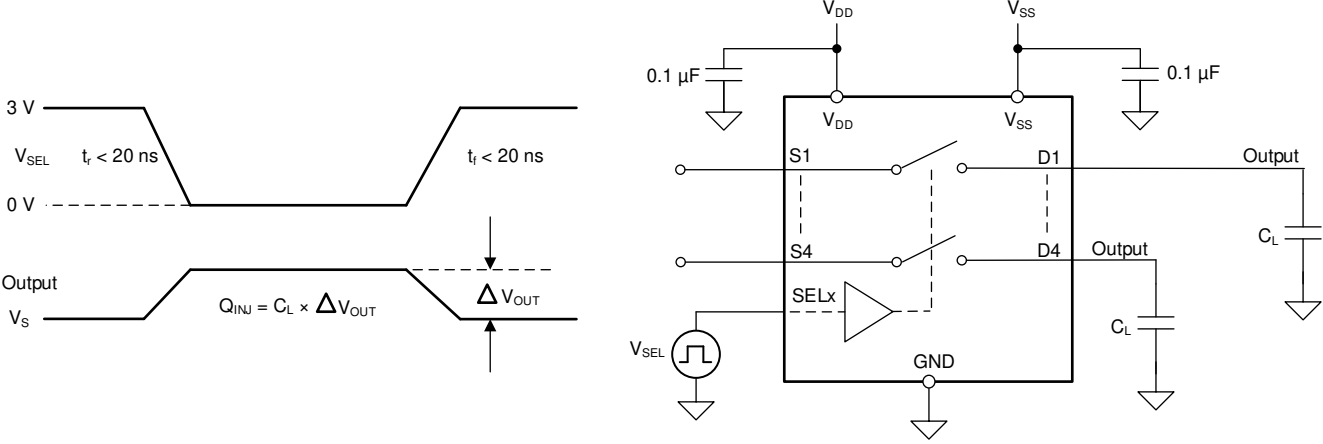
The TMUX721x devices have a transmission-gate topology. Any mismatch in capacitance between the NMOS and PMOS transistors results in a charge injected into the drain or source during the falling or rising edge of the gate signal. The amount of charge injected into the source or drain of the device is known as charge injection, and is denoted by the symbol  $Q_C$ .  shows the setup used to measure charge injection from source (Sx) to drain (Dx).

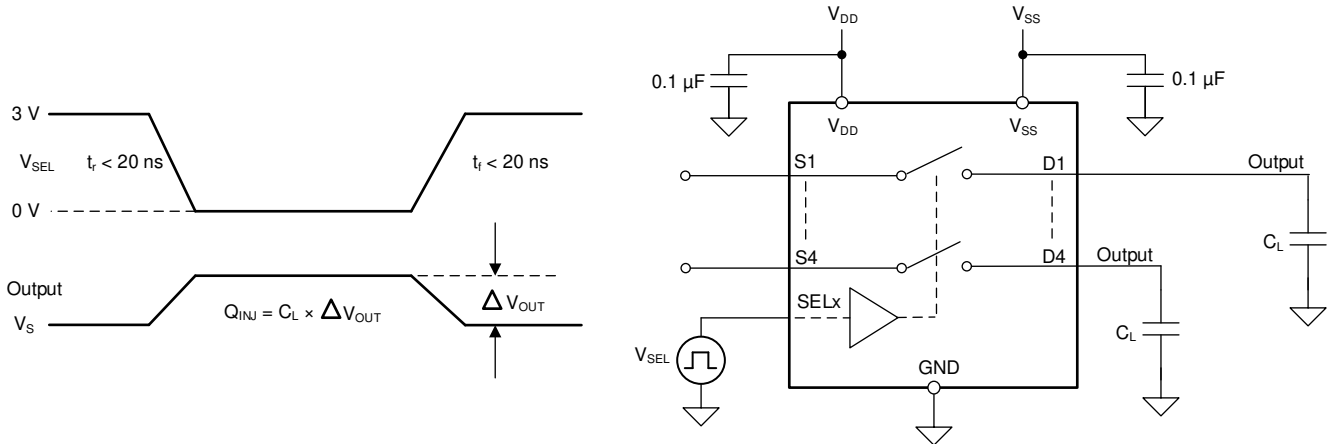

 7-7. Charge-Injection Measurement Setup

## 7.8 Off Isolation

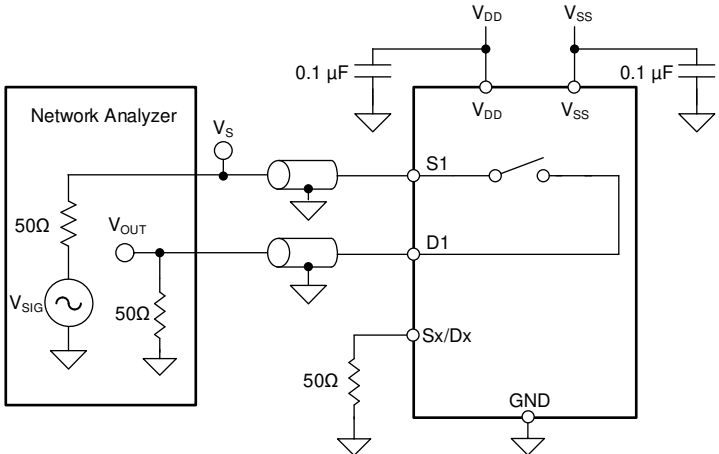
Off isolation is defined as the ratio of the signal at the drain pin (Dx) of the device when a signal is applied to the source pin (Sx) of an off-channel. The characteristic impedance,  $Z_0$ , for the measurement is 50  $\Omega$ .  shows the setup used to measure off isolation. Use off isolation equation to compute off isolation.

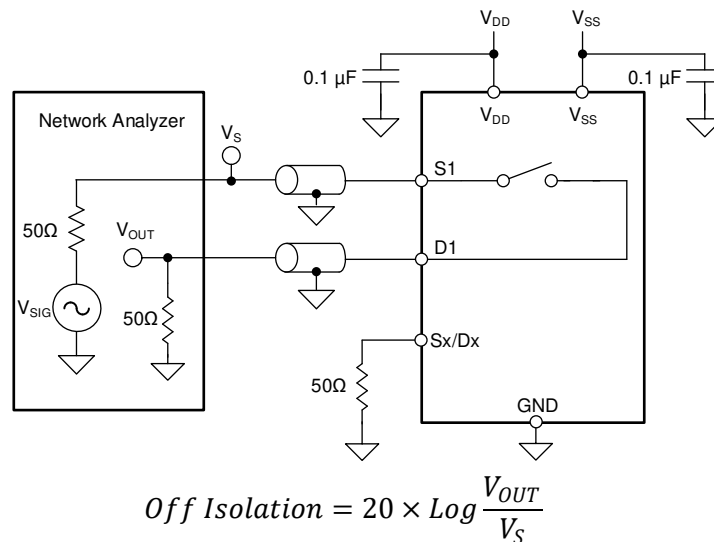

 7-8. Off Isolation Measurement Setup

## 7.9 Channel-to-Channel Crosstalk

Crosstalk is defined as the ratio of the signal at the drain pin (Dx) of a different channel, when a signal is applied at the source pin (Sx) of an on-channel. The characteristic impedance,  $Z_0$ , for the measurement is 50  $\Omega$ .  7-9 shows the setup used to measure, and the equation used to compute crosstalk.

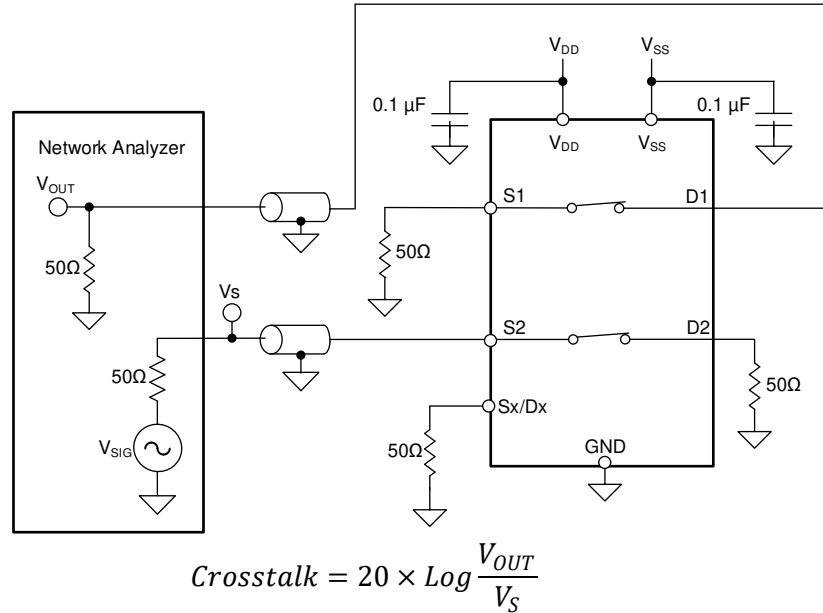

 7-9. Channel-to-Channel Crosstalk Measurement Setup

## 7.10 Bandwidth

Bandwidth is defined as the range of frequencies that are attenuated by less than 3 dB when the input is applied to the source pin (Sx) of an on-channel, and the output is measured at the drain pin (Dx) of the device. The characteristic impedance,  $Z_0$ , for the measurement is 50  $\Omega$ .  7-10 shows the setup used to measure bandwidth.

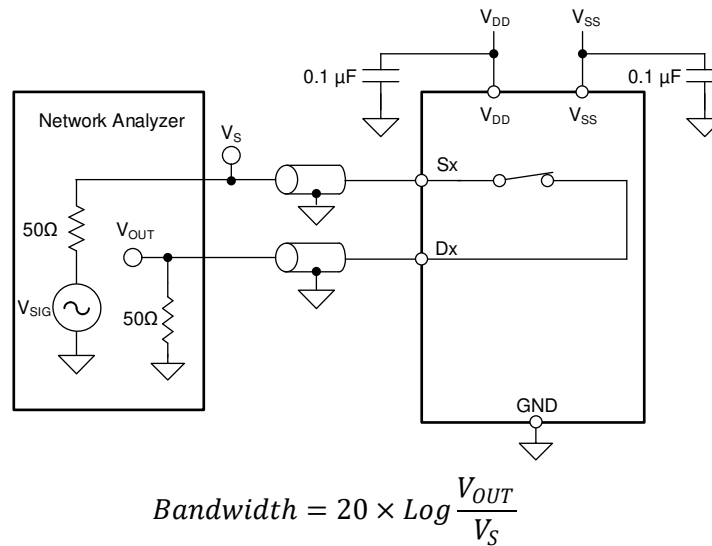

 7-10. Bandwidth Measurement Setup



### 7.11 THD + Noise

The total harmonic distortion (THD) of a signal is a measurement of the harmonic distortion, and is defined as the ratio of the sum of the powers of all harmonic components to the power of the fundamental frequency at the mux output. The on-resistance of the device varies with the amplitude of the input signal and results in distortion when the drain pin is connected to a low-impedance load. Total harmonic distortion plus noise is denoted as THD + N.

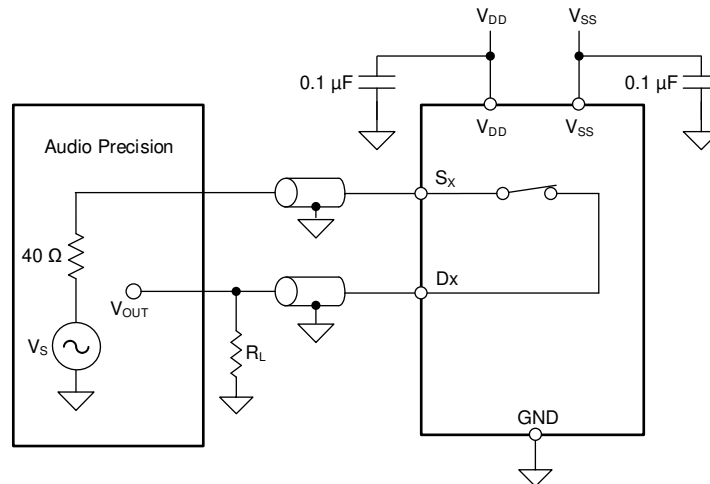

Figure 7-11. THD + N Measurement Setup

### 7.12 Power Supply Rejection Ratio (PSRR)

PSRR measures the ability of a device to prevent noise and spurious signals that appear on the supply voltage pin from coupling to the output of the switch. The DC voltage on the device supply is modulated by a sine wave of 100 mV<sub>PP</sub>. The ratio of the amplitude of signal on the output to the amplitude of the modulated signal is the AC PSRR.

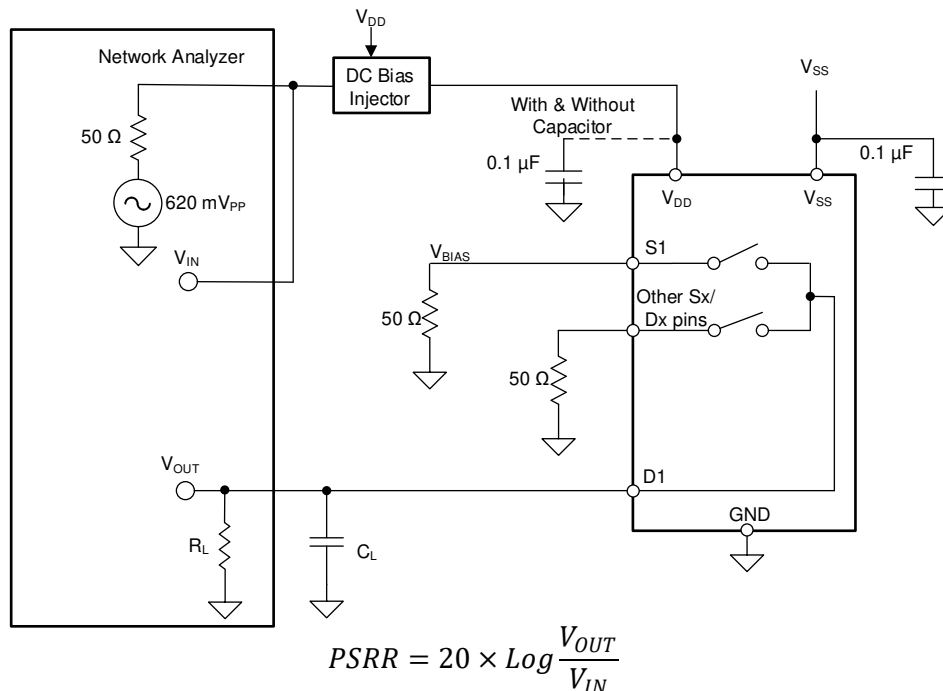

Figure 7-12. AC PSRR Measurement Setup

## 8 Detailed Description

### 8.1 Overview

The TMUX7212 is a 1:1 (SPST), 4-channel switch. The device has four independently selectable single-pole, single-throw switches that are turned-on or turned-off based on the state of the corresponding select pin.

### 8.2 Functional Block Diagram

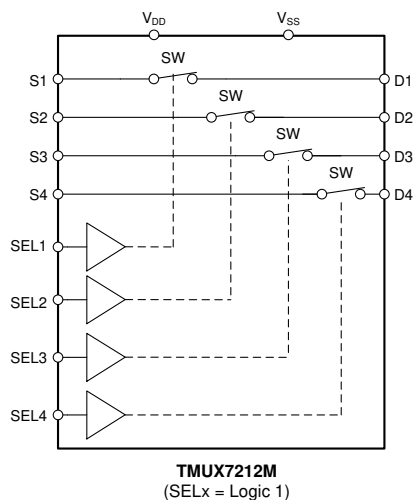

### 8.3 Feature Description

#### 8.3.1 Bidirectional Operation

The TMUX721x conducts equally well from source (Sx) to drain (Dx) or from drain (Dx) to source (Sx). Each channel has similar characteristics in both directions and supports both analog and digital signals.

#### 8.3.2 Rail-to-Rail Operation

The valid signal path input and output voltage for TMUX721x ranges from  $V_{SS}$  to  $V_{DD}$ .

#### 8.3.3 1.8V Logic Compatible Inputs

The TMUX721x device has 1.8V logic compatible control for all logic control inputs. 1.8V logic level inputs allows the TMUX721x to interface with processors that have lower logic I/O rails and eliminates the need for an external translator, which saves both space and bill of material cost. For more information on 1.8V logic implementations refer to [Simplifying Design with 1.8V logic Muxes and Switches](#).

#### 8.3.4 Integrated Pull-Down Resistor on Logic Pins

The TMUX721x has internal weak pull-down resistors to GND to ensure the logic pins are not left floating. The value of this pull-down resistor is approximately  $4M\Omega$ , but is clamped to about  $1\ \mu A$  at higher voltages. This feature integrates up to four external components and reduces system size and cost.

#### 8.3.5 Fail-Safe Logic

The TMUX721x supports Fail-Safe Logic on the control input pins (SEL1, SEL2, SEL3, and SEL4) allowing for operation up to 44V, regardless of the state of the supply pin. This feature allows voltages on the control pins to be applied before the supply pin, protecting the device from potential damage. Fail-Safe Logic minimizes system complexity by removing the need for power supply sequencing on the logic control pins. For example, the Fail-Safe Logic feature allows the select pins of the TMUX721x to be ramped to 44V while  $V_{DD}$  and  $V_{SS} = 0V$ . The logic control inputs are protected against positive faults of up to 44V in powered-off condition, but do not offer protection against negative overvoltage conditions.

### 8.3.6 Latch-Up Immune

Latch-up is a condition where a low impedance path is created between a supply pin and ground. This condition is caused by a trigger (current injection or overvoltage), but once activated, the low impedance path remains even after the trigger is no longer present. This low impedance path may cause system upset or catastrophic damage due to excessive current levels. The latch-up condition typically requires a power cycle to eliminate the low impedance path.

The TMUX721x family of devices are constructed on silicon on insulator (SOI) based process where an oxide layer is added between the PMOS and NMOS transistor of each CMOS switch to prevent parasitic structures from forming. The oxide layer is also known as an insulating trench and prevents triggering of latch up events due to overvoltage or current injections. The latch-up immunity feature allows the TMUX721x family of switches and multiplexers to be used in harsh environments. For more information on latch-up immunity refer to [Using Latch Up Immune Multiplexers to Help Improve System Reliability](#).

### 8.3.7 Ultra-Low Charge Injection

**8-1** shows how the TMUX721x devices have a transmission gate topology. Any mismatch in the stray capacitance associated with the NMOS and PMOS causes an output level change whenever the switch is opened or closed.

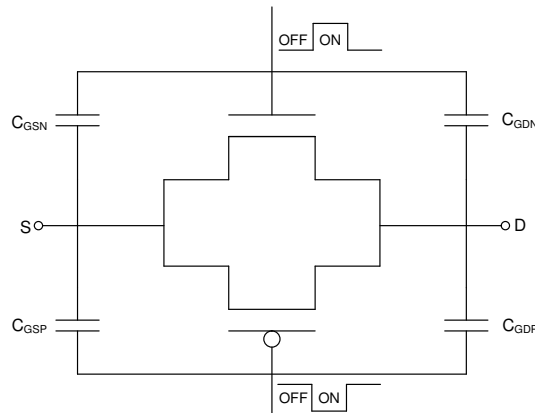

 **8-1. Transmission Gate Topology**

The TMUX721x contains specialized architecture to reduce charge injection on the Drain (Dx). To further reduce charge injection in a sensitive application, a compensation capacitor (Cp) can be added on the Source (Sx). This will ensure that excess charge from the switch transition will be pushed into the compensation capacitor on the Source (Sx) instead of the Drain (Dx). As a general rule, Cp should be 20x larger than the equivalent load capacitance on the Drain (Dx).  **8-2** shows charge injection variation with different compensation capacitors on the Source side. This plot was captured on the TMUX7219M as part of the TMUX72xx family with a 100 pF load capacitance.



図 8-2. Charge Injection Compensation

## 8.4 Device Functional Modes

The TMUX721x device has four independently selectable single-pole, single-throw switches that are turned-on or turned-off based on the state of the corresponding select pin. The control pins can be as high as 44V.

The TMUX721x devices can operate without any external components except for the supply decoupling capacitors. The SELx pins have internal pull-down resistors of 4MΩ. If unused, then the SELx pin must be tied to GND for the device to not consume additional current as highlighted in [Implications of Slow or Floating CMOS Inputs](#). Unused signal path inputs (Sx or Dx) should be connected to GND.

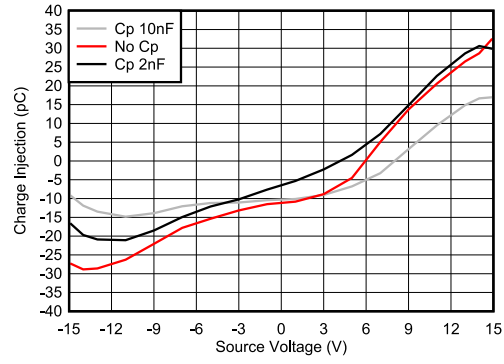
## 8.5 Truth Tables

表 8-1 shows the truth tables for the TMUX7212.

表 8-1. TMUX7212 Truth Table

SEL x <sup>(1)</sup>	CHANNEL x
0	Channel x OFF
1	Channel x ON

(1) x denotes 1, 2, 3, or 4 for the corresponding channel.

## 9 Application and Implementation

### 注

以下のアプリケーション情報は、TI の製品仕様に含まれるものではなく、TI ではその正確性または完全性を保証いたしません。個々の目的に対する製品の適合性については、お客様の責任で判断していただくこととなります。お客様は自身の設計実装を検証しテストすることで、システムの機能を確認する必要があります。

### 9.1 Application Information

The TMUX721x is part of the precision switches and multiplexers family of devices. These devices operate with dual supplies ( $\pm 4.5\text{ V}$  to  $\pm 22\text{ V}$ ), a single supply (4.5 V to 44V), or asymmetric supplies (such as  $V_{DD} = 12\text{ V}$ ,  $V_{SS} = -5\text{ V}$ ), and offer true rail-to-rail input and output. The TMUX721x offers low  $R_{ON}$ , low on and off leakage currents and ultra-low charge injection performance. These features makes the TMUX721x a family of precision, robust, high-performance analog multiplexer for high-voltage, industrial applications.

### 9.2 Typical Application

One example to take advantage of TMUX721x precision performance is the implementation of parametric measurement unit (PMU) in the semiconductor automatic test equipment (ATE) application.

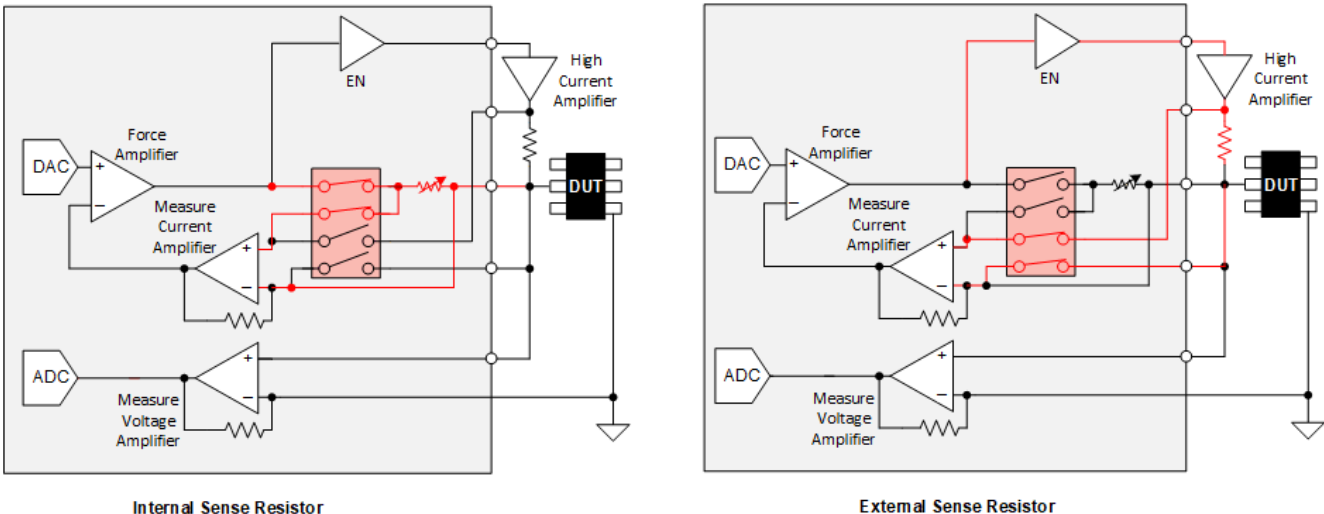
In Automated Test Equipment (ATE) systems, the Parametric Measurement Unit (PMU) is tasked to measure device (DUT) parametric information in terms of voltage and current. When measuring voltage, current is applied at the DUT pin, and current range adjustment can be done through changing the value of the internal sense resistor. There is sometimes a need, depending on the DUT, to use even higher testing current than natively supported by the system. A 4 channel SPST switch, together with external higher current amplifier and resistor, can be used to achieve the flexibility. The PMU operating voltage is typically in mid voltage (up to 20 V). An appropriate switch like the TMUX721x with low leakage current (0.05 nA typical) works well in these applications to ensure measurement accuracy and low  $R_{ON}$  and flat  $R_{ON\_FLATNESS}$  allows the current range to be controlled more precisely.  shows simplified diagram of such implementations in memory and semiconductor test equipment.



図 9-1. High Current Range Selection Using External Resistor

### 9.2.1 Design Requirements

For this design example, use the parameters listed in 表 9-1.

**表 9-1. Design Parameters**

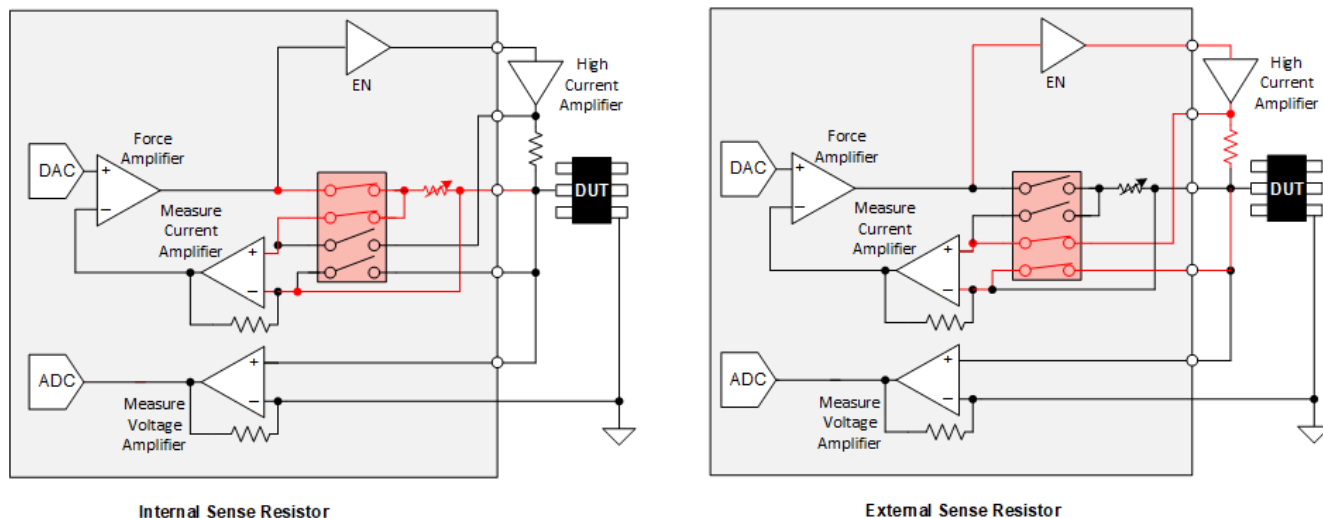
PARAMETERS	VALUES
Supply ( $V_{DD}$ )	20 V
Supply ( $V_{SS}$ )	-10 V
Input / Output signal range	-10 V to 20 V (Rail-to-Rail)
Control logic thresholds	1.8 V compatible

### 9.2.2 Detailed Design Procedure

Figure 10-1 demonstrates how the TMUX721x can be used in semiconductor test equipment for high-precision, high-voltage, multi-channel measurement applications. The TMUX721x can support 1.8 V logic signals on the control input, allowing the device to interface with low logic controls of an FPGA or MCU. The TMUX721x can be operated without any external components except for the supply decoupling capacitors. The select pins have an internal pull-down resistor to prevent floating input logic. All inputs to the switch must fall within the recommend operating conditions of the TMUX721x including signal range and continuous current. For this design with a positive supply of 20 V on  $V_{DD}$ , and negative supply of -10 V on  $V_{SS}$ , the signal range can be 20 V to -10 V. The max continuous current ( $I_{DC}$ ) can be up to 330 mA as shown in the *Recommended Operating Conditions* table for wide-range current measurement.

### 9.2.3 Application Curve

The TMUX721x have excellent charge injection performance and ultra-low leakage current, making them ideal choices to minimize sampling error for the sample and hold application.

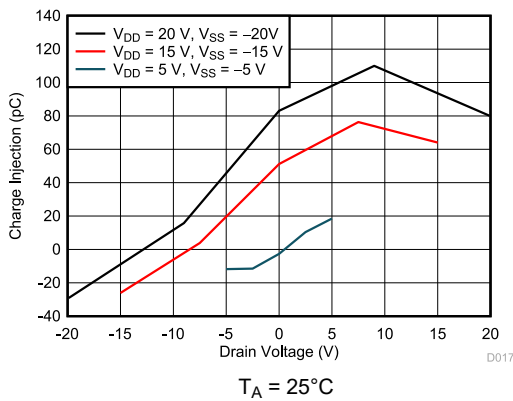

☒ 9-2. Charge Injection vs. Drain Voltage

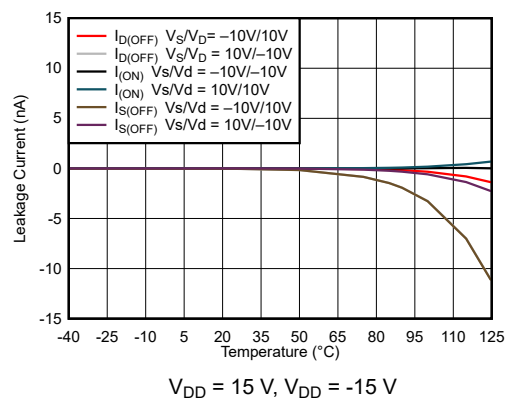

☒ 9-3. On-Leakage vs. Source or Drain Voltage

## 9.3 Power Supply Recommendations

The TMUX721x device operates across a wide supply range of  $\pm 4.5V$  to  $\pm 22V$  (4.5V to 44V in single-supply mode). The device also perform well with asymmetrical supplies such as  $V_{DD} = 12 V$  and  $V_{SS} = -5 V$ .

Power-supply bypassing improves noise margin and prevents switching noise propagation from the supply rails to other components. Good power-supply decoupling is important to achieve optimum performance. For improved supply noise immunity, use a supply decoupling capacitor ranging from 0.1  $\mu F$  to 10  $\mu F$  at both the  $V_{DD}$  and  $V_{SS}$  pins to ground. Place the bypass capacitors as close to the power supply pins of the device as possible using low-impedance connections. TI recommends using multi-layer ceramic chip capacitors (MLCCs) that offer low equivalent series resistance (ESR) and inductance (ESL) characteristics for power-supply decoupling purposes. For very sensitive systems, or for systems in harsh noise environments, avoiding the use of vias for connecting the capacitors to the device pins may offer superior noise immunity. The use of multiple vias in

parallel lowers the overall inductance and is beneficial for connections to ground and power planes. Always ensure the ground (GND) connection is established before supplies are ramped.

## 9.4 Layout

### 9.4.1 Layout Guidelines

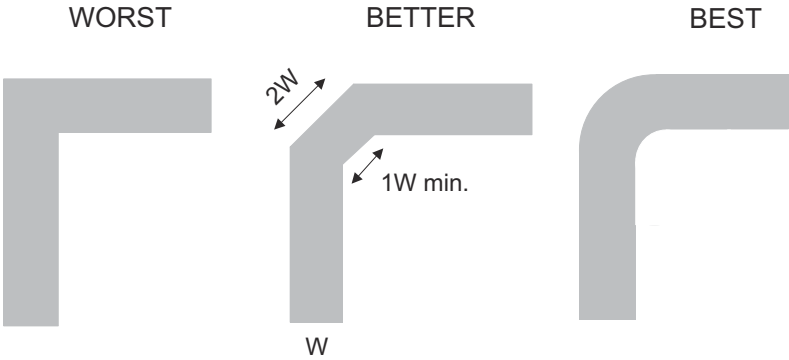
When a PCB trace turns a corner at a 90° angle, a reflection can occur. A reflection occurs primarily because of the change of width of the trace. At the apex of the turn, the trace width increases to 1.414 times the width. This increase upsets the transmission-line characteristics, especially the distributed capacitance and self-inductance of the trace which results in the reflection. Not all PCB traces can be straight and therefore some traces must turn corners.  9-4 shows progressively better techniques of rounding corners. Only the last example (BEST) maintains constant trace width and minimizes reflections.

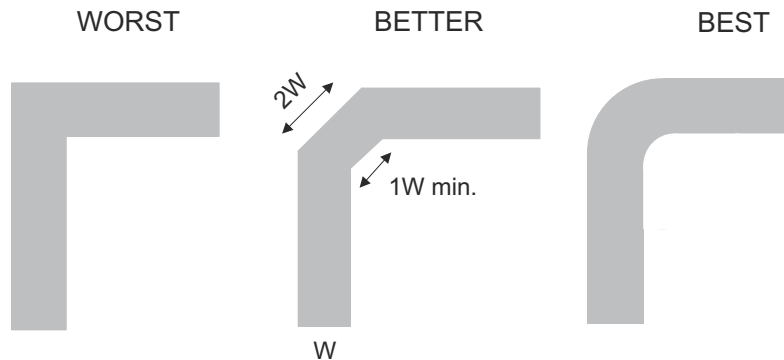

 9-4. Trace Example

Route high-speed signals using a minimum of vias and corners which reduces signal reflections and impedance changes. When a via must be used, increase the clearance size around it to minimize its capacitance. Each via introduces discontinuities in the signal's transmission line and increases the chance of picking up interference from the other layers of the board. Be careful when designing test points, through-hole pins are not recommended at high frequencies.

Some key considerations are:

- For reliable operation, connect a decoupling capacitor ranging from 0.1 $\mu$ F to 10 $\mu$ F between VDD/VSS and GND. We recommend a 0.1 $\mu$ F and 1 $\mu$ F capacitor, placing the lowest value capacitor as close to the pin as possible. Make sure that the capacitor voltage rating is sufficient for the supply voltage.
- Keep the input lines as short as possible.
- Use a solid ground plane to help reduce electromagnetic interference (EMI) noise pickup.
- Do not run sensitive analog traces in parallel with digital traces. Avoid crossing digital and analog traces if possible, and only make perpendicular crossings when necessary.
- Using multiple vias in parallel will lower the overall inductance and is beneficial for connection to ground planes.



### 9.4.2 Layout Example

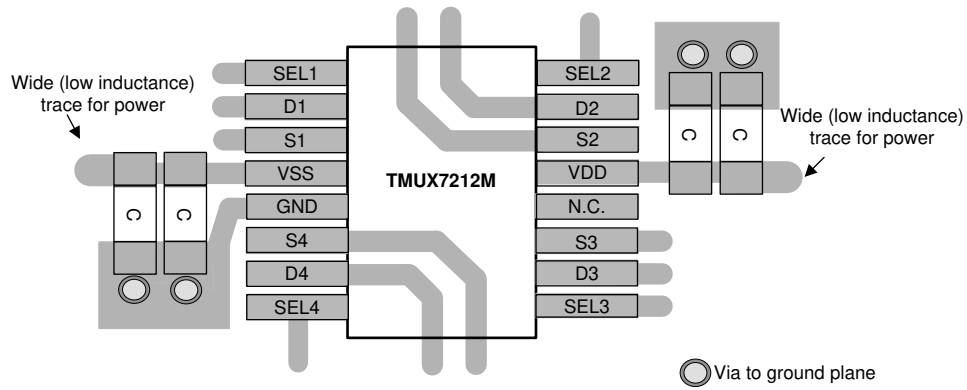

☒ 9-5. TMUX721x Layout Example

## 10 Device and Documentation Support

### 10.1 Documentation Support

#### 10.1.1 Related Documentation

- Texas Instruments, [Using Latch Up Immune Multiplexers to Help Improve System Reliability](#) application note
- Texas Instruments, [Improve Stability Issues with Low CON Multiplexers](#) application brief
- Texas Instruments, [Improving Signal Measurement Accuracy in Automated Test Equipment](#) application brief
- Texas Instruments, [Sample & Hold Glitch Reduction for Precision Outputs Reference Design](#) reference guide
- Texas Instruments, [Simplifying Design with 1.8V logic Muxes and Switches](#) application brief
- Texas Instruments, [System-Level Protection for High-Voltage Analog Multiplexers](#) application note
- Texas Instruments, [True Differential, 4 x 2 MUX, Analog Front End, Simultaneous-Sampling ADC Circuit](#) application note
- Texas Instruments, [Quad Flatpack No-Lead Logic Packages](#) application note

### 10.2 ドキュメントの更新通知を受け取る方法

ドキュメントの更新についての通知を受け取るには、[www.tij.co.jp](http://www.tij.co.jp) のデバイス製品フォルダを開いてください。[通知] をクリックして登録すると、変更されたすべての製品情報に関するダイジェストを毎週受け取ることができます。変更の詳細については、改訂されたドキュメントに含まれている改訂履歴をご覧ください。

### 10.3 サポート・リソース

テキサス・インスツルメンツ E2E™ サポート・フォーラムは、エンジニアが検証済みの回答と設計に関するヒントをエキスパートから迅速かつ直接得ることができる場所です。既存の回答を検索したり、独自の質問をしたりすることで、設計に必要な支援を迅速に得ることができます。

リンクされているコンテンツは、各寄稿者により「現状のまま」提供されるものです。これらはテキサス・インスツルメンツの仕様を構成するものではなく、必ずしもテキサス・インスツルメンツの見解を反映したものではありません。テキサス・インスツルメンツの[使用条件](#)を参照してください。

### 10.4 Trademarks

テキサス・インスツルメンツ E2E™ is a trademark of Texas Instruments.  
すべての商標は、それぞれの所有者に帰属します。

### 10.5 静電気放電に関する注意事項



この IC は、ESD によって破損する可能性があります。テキサス・インスツルメンツは、IC を取り扱う際には常に適切な注意を払うことを推奨します。正しい取り扱いおよび設置手順に従わない場合、デバイスを破損するおそれがあります。

ESD による破損は、わずかな性能低下からデバイスの完全な故障まで多岐にわたります。精密な IC の場合、パラメータがわずかに変化するだけで公表されている仕様から外れる可能性があるため、破損が発生しやすくなっています。

### 10.6 用語集

[テキサス・インスツルメンツ用語集](#) この用語集には、用語や略語の一覧および定義が記載されています。

## 11 Revision History

資料番号末尾の英字は改訂を表しています。その改訂履歴は英語版に準じています。

Changes from Revision C (August 2021) to Revision D (July 2024)	Page
• Update HBM ESD value on PW and RUM package.....	5
• Updated IIH max specification.....	7

Changes from Revision B (April 2021) to Revision C (August 2021)	Page
• TMUX7211、TMUX7212、TMUX7213 の QFN パッケージを追加.....	1
• Added ESD detail for RUM package.....	5
• Changed THD+N typical for 12V supply.....	14
• Added the <i>Integrated Pull-Down Resistor on Logic Pins</i> section.....	26
• Updated the <i>Ultra-Low Charge Injection</i> section.....	27
• Updated the <i>TMUX721x Layout Example</i> figure in the <i>Layout Example</i> section.....	33

Changes from Revision A (March 2021) to Revision B (April 2021)	Page
• Included Break-before-make time delay for TMUX7213 .....	8
• Updated the <i>Charge Injection Compensation</i> figure.....	27

Changes from Revision * (December 2020) to Revision A (March 2021)	Page
• 「特長」セクションに WQFN の大電流サポートを追加.....	1
• Added thermal information for QFN package.....	6
• Updated I <sub>DC</sub> specs for TSSOP package in <i>Source or Drain Continuous Current</i> table .....	6
• Added I <sub>DC</sub> specs for QFN package in <i>Source or Drain Continuous Current</i> table .....	6
• Updated V <sub>DD</sub> rise time value from 100ns to 1μs in T <sub>ON(VDD)</sub> test condition.....	8
• Updated C <sub>L</sub> value from 1nF to 100pF in Charge Injection test condition.....	8
• Updated Figure 7-10 <i>Leakage Current vs. Temperature</i> .....	15

## 12 Mechanical, Packaging, and Orderable Information

The following pages include mechanical, packaging, and orderable information. This information is the most current data available for the designated devices. This data is subject to change without notice and revision of this document. For browser-based versions of this data sheet, refer to the left-hand navigation.

**PW0016A**



**PACKAGE OUTLINE**  
**TSSOP - 1.2 mm max height**

SMALL OUTLINE PACKAGE

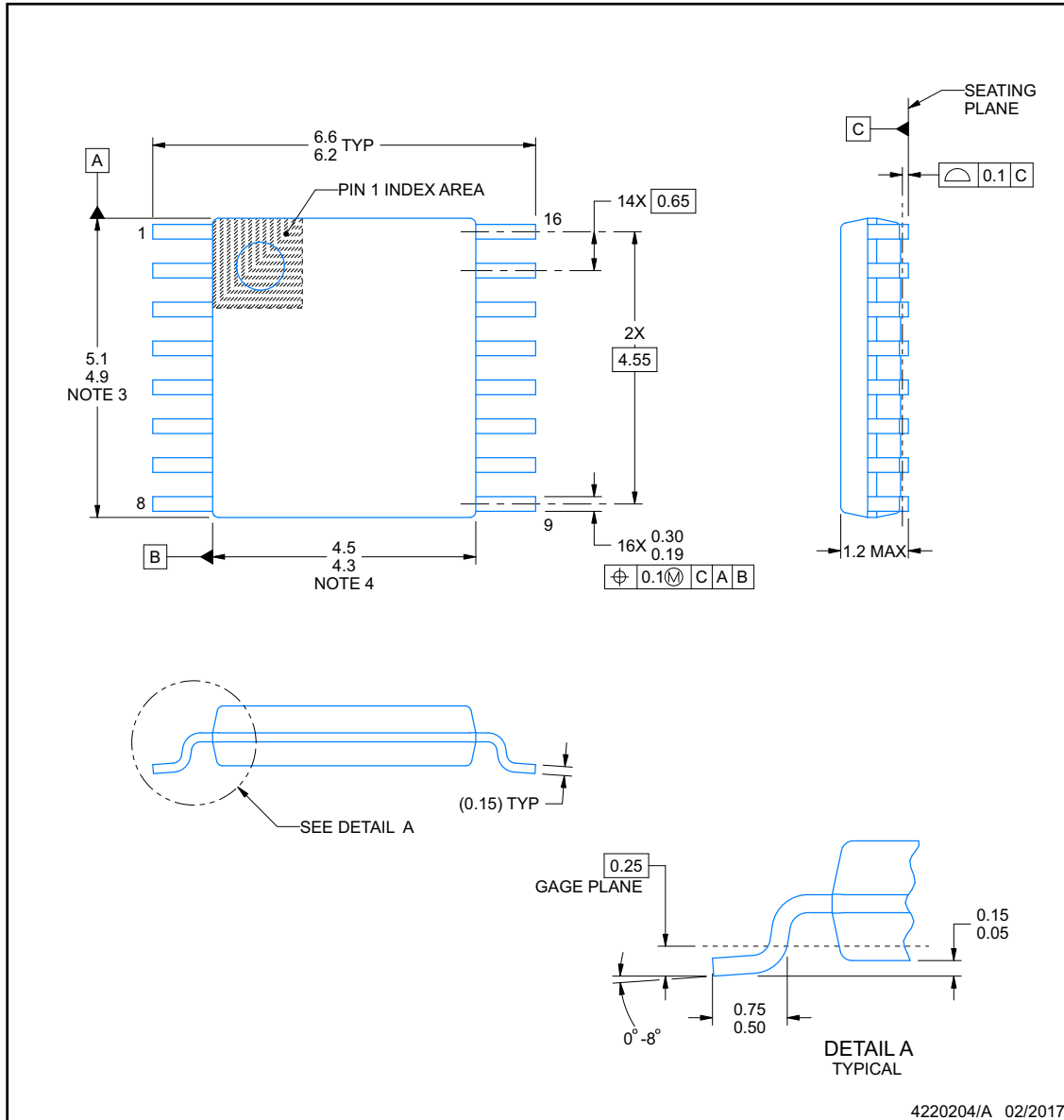

NOTES:

1. All linear dimensions are in millimeters. Any dimensions in parenthesis are for reference only. Dimensioning and tolerancing per ASME Y14.5M.
2. This drawing is subject to change without notice.
3. This dimension does not include mold flash, protrusions, or gate burrs. Mold flash, protrusions, or gate burrs shall not exceed 0.15 mm per side.
4. This dimension does not include interlead flash. Interlead flash shall not exceed 0.25 mm per side.
5. Reference JEDEC registration MO-153.

## EXAMPLE BOARD LAYOUT

**PW0016A**

**TSSOP - 1.2 mm max height**

SMALL OUTLINE PACKAGE

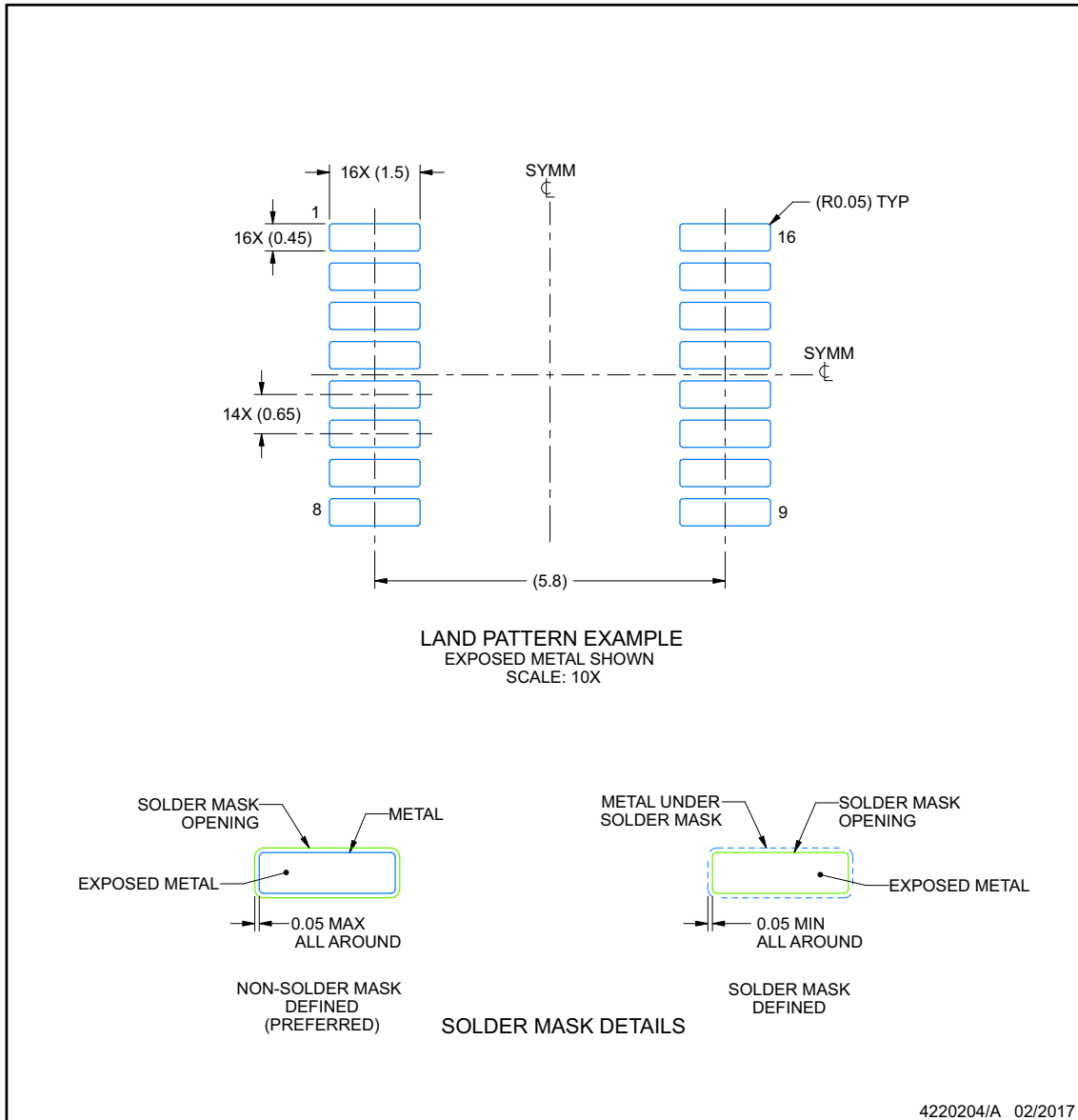

NOTES: (continued)

- 6. Publication IPC-7351 may have alternate designs.
- 7. Solder mask tolerances between and around signal pads can vary based on board fabrication site.

## EXAMPLE STENCIL DESIGN

**PW0016A**

**TSSOP - 1.2 mm max height**

SMALL OUTLINE PACKAGE

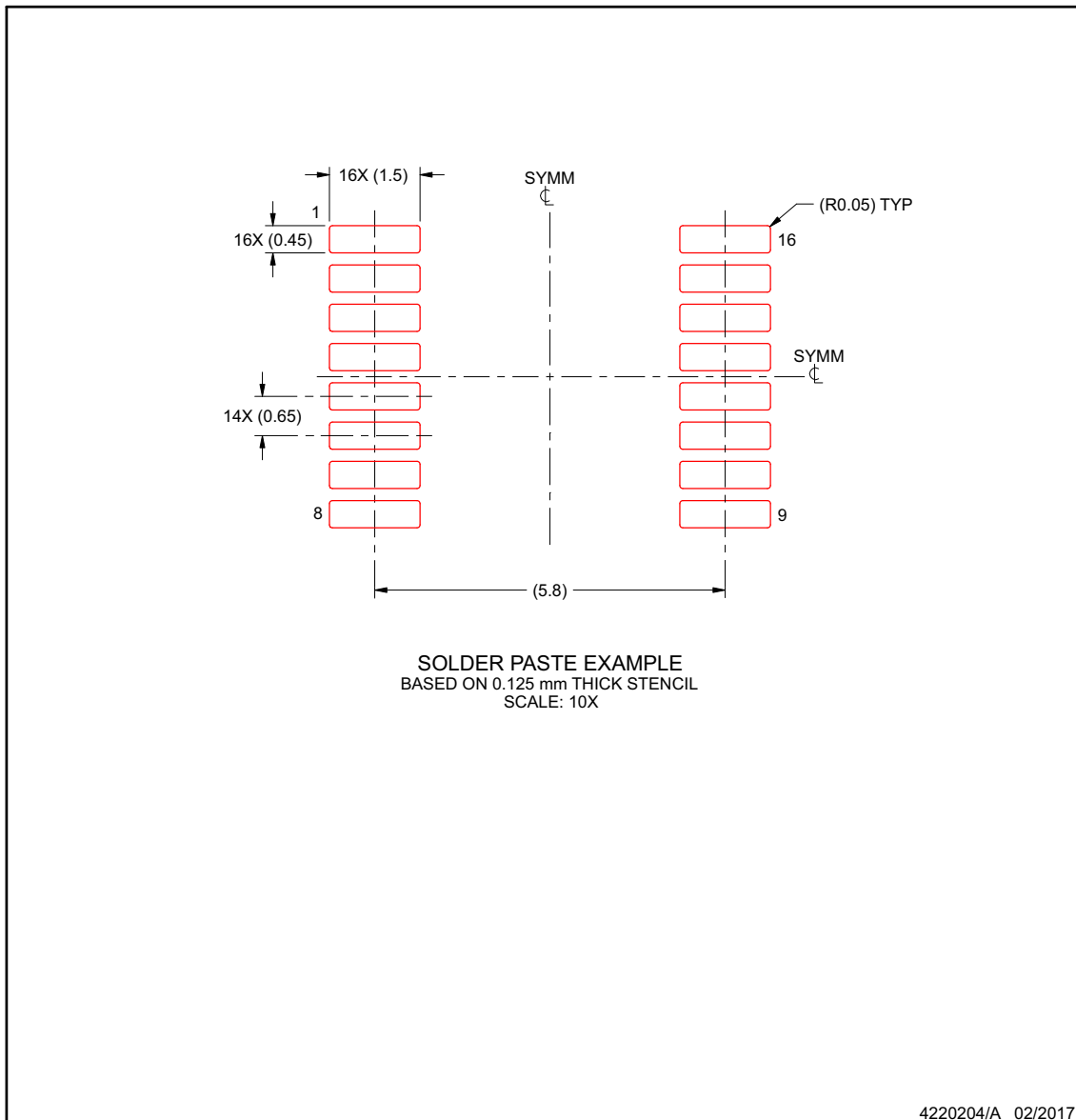

NOTES: (continued)

- 8. Laser cutting apertures with trapezoidal walls and rounded corners may offer better paste release. IPC-7525 may have alternate design recommendations.
- 9. Board assembly site may have different recommendations for stencil design.



## EXAMPLE BOARD LAYOUT

**RUM0016E**

**WQFN - 0.8 mm max height**

PLASTIC QUAD FLATPACK - NO LEAD

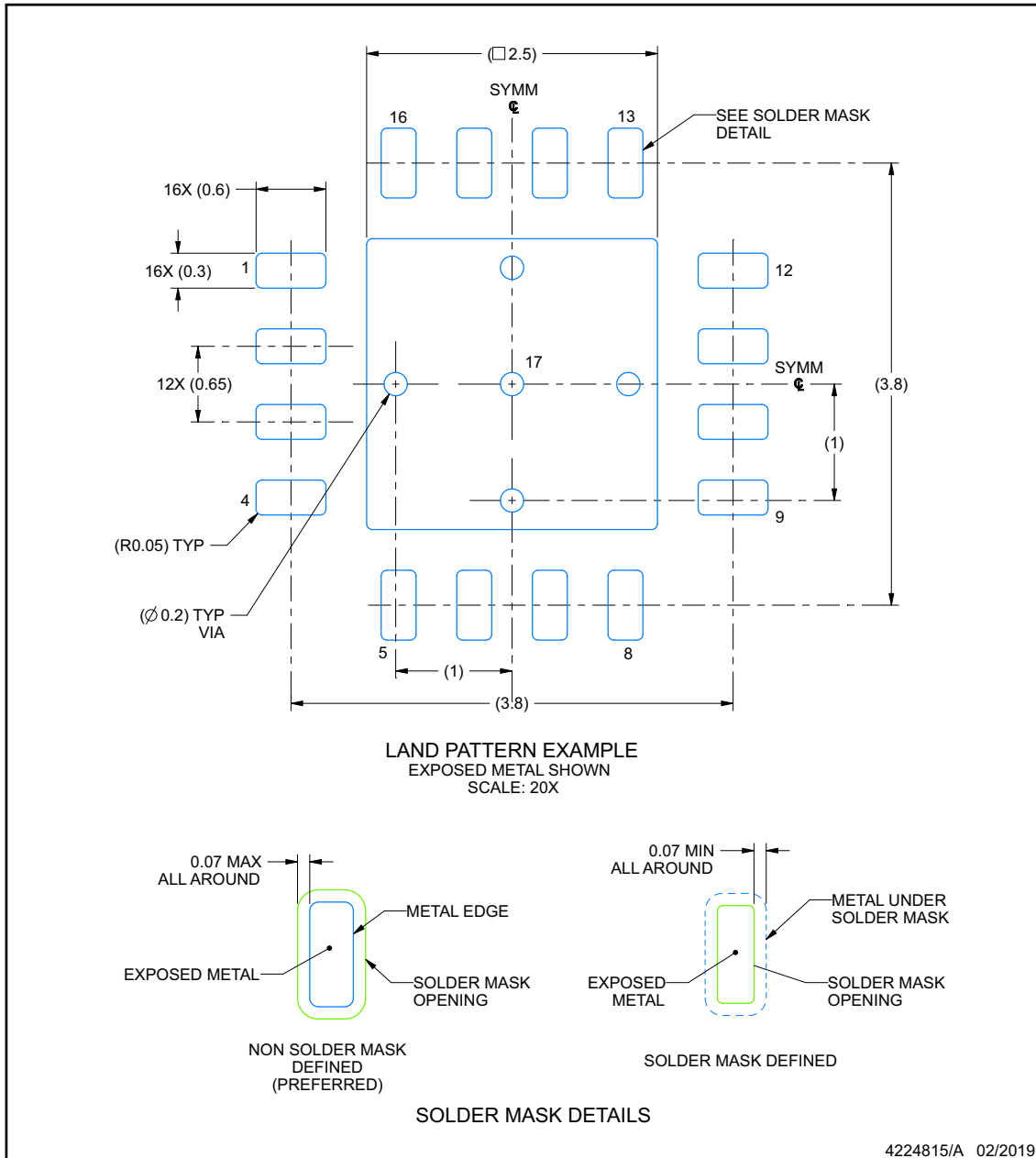

NOTES: (continued)

4. This package is designed to be soldered to a thermal pad on the board. For more information, see Texas Instruments literature number SLUA271 ([www.ti.com/lit/sluea271](http://www.ti.com/lit/sluea271)).
5. Vias are optional depending on application, refer to device data sheet. If any vias are implemented, refer to their locations shown on this view. It is recommended that vias under paste be filled, plugged or tented.





## 重要なお知らせと免責事項

テキサス・インスツルメンツは、技術データと信頼性データ (データシートを含みます)、設計リソース (リファレンス デザインを含みます)、アプリケーションや設計に関する各種アドバイス、Web ツール、安全性情報、その他のリソースを、欠陥が存在する可能性のある「現状のまま」提供しており、商品性および特定目的に対する適合性の黙示保証、第三者の知的財産権の非侵害保証を含むいかなる保証も、明示的または黙示的にかかわらず拒否します。

これらのリソースは、テキサス・インスツルメンツ製品を使用する設計の経験を積んだ開発者への提供を意図したものです。(1) お客様のアプリケーションに適した テキサス・インスツルメンツ製品の選定、(2) お客様のアプリケーションの設計、検証、試験、(3) お客様のアプリケーションに該当する各種規格や、その他のあらゆる安全性、セキュリティ、規制、または他の要件への確実な適合に関する責任を、お客様のみが単独で負うものとします。

上記の各種リソースは、予告なく変更される可能性があります。これらのリソースは、リソースで説明されている テキサス・インスツルメンツ製品を使用するアプリケーションの開発の目的でのみ、テキサス・インスツルメンツはその使用をお客様に許諾します。これらのリソースに関して、他の目的で複製することや掲載することは禁止されています。テキサス・インスツルメンツや第三者の知的財産権のライセンスが付与されている訳ではありません。お客様は、これらのリソースを自身で使用した結果発生するあらゆる申し立て、損害、費用、損失、責任について、テキサス・インスツルメンツおよびその代理人を完全に補償するものとし、テキサス・インスツルメンツは一切の責任を拒否します。

テキサス・インスツルメンツの製品は、[テキサス・インスツルメンツの販売条件](#)、または [ti.com](https://www.ti.com) やかかる テキサス・インスツルメンツ製品の関連資料などのいずれかを通じて提供する適用可能な条項の下で提供されています。テキサス・インスツルメンツがこれらのリソースを提供することは、適用されるテキサス・インスツルメンツの保証または他の保証の放棄の拡大や変更を意味するものではありません。

お客様がいかなる追加条項または代替条項を提案した場合でも、テキサス・インスツルメンツはそれらに異議を唱え、拒否します。

郵送先住所: Texas Instruments, Post Office Box 655303, Dallas, Texas 75265

Copyright © 2024, Texas Instruments Incorporated

**PACKAGING INFORMATION**

Orderable Device	Status (1)	Package Type	Package Drawing	Pins	Package Qty	Eco Plan (2)	Lead finish/ Ball material (6)	MSL Peak Temp (3)	Op Temp (°C)	Device Marking (4/5)	Samples
TMUX7211PWR	ACTIVE	TSSOP	PW	16	2000	RoHS & Green	NIPDAU	Level-1-260C-UNLIM	-40 to 125	X211	<a href="#">Samples</a>
TMUX7211RUMR	ACTIVE	WQFN	RUM	16	3000	RoHS & Green	NIPDAU	Level-1-260C-UNLIM	-40 to 125	TMUX X211	<a href="#">Samples</a>
TMUX7212PWR	ACTIVE	TSSOP	PW	16	2000	RoHS & Green	NIPDAU	Level-1-260C-UNLIM	-40 to 125	X212	<a href="#">Samples</a>
TMUX7212RUMR	ACTIVE	WQFN	RUM	16	3000	RoHS & Green	NIPDAU	Level-1-260C-UNLIM	-40 to 125	TMUX X212	<a href="#">Samples</a>
TMUX7213PWR	ACTIVE	TSSOP	PW	16	2000	RoHS & Green	NIPDAU	Level-1-260C-UNLIM	-40 to 125	X213	<a href="#">Samples</a>
TMUX7213RUMR	ACTIVE	WQFN	RUM	16	3000	RoHS & Green	NIPDAU	Level-1-260C-UNLIM	-40 to 125	TMUX X213	<a href="#">Samples</a>

(1) The marketing status values are defined as follows:

**ACTIVE:** Product device recommended for new designs.

**LIFEBUY:** TI has announced that the device will be discontinued, and a lifetime-buy period is in effect.

**NRND:** Not recommended for new designs. Device is in production to support existing customers, but TI does not recommend using this part in a new design.

**PREVIEW:** Device has been announced but is not in production. Samples may or may not be available.

**OBSOLETE:** TI has discontinued the production of the device.

(2) **RoHS:** TI defines "RoHS" to mean semiconductor products that are compliant with the current EU RoHS requirements for all 10 RoHS substances, including the requirement that RoHS substance do not exceed 0.1% by weight in homogeneous materials. Where designed to be soldered at high temperatures, "RoHS" products are suitable for use in specified lead-free processes. TI may reference these types of products as "Pb-Free".

**RoHS Exempt:** TI defines "RoHS Exempt" to mean products that contain lead but are compliant with EU RoHS pursuant to a specific EU RoHS exemption.

**Green:** TI defines "Green" to mean the content of Chlorine (Cl) and Bromine (Br) based flame retardants meet JS709B low halogen requirements of <=1000ppm threshold. Antimony trioxide based flame retardants must also meet the <=1000ppm threshold requirement.

(3) MSL, Peak Temp. - The Moisture Sensitivity Level rating according to the JEDEC industry standard classifications, and peak solder temperature.

(4) There may be additional marking, which relates to the logo, the lot trace code information, or the environmental category on the device.

(5) Multiple Device Markings will be inside parentheses. Only one Device Marking contained in parentheses and separated by a "~" will appear on a device. If a line is indented then it is a continuation of the previous line and the two combined represent the entire Device Marking for that device.

<sup>(6)</sup> Lead finish/Ball material - Orderable Devices may have multiple material finish options. Finish options are separated by a vertical ruled line. Lead finish/Ball material values may wrap to two lines if the finish value exceeds the maximum column width.

**Important Information and Disclaimer:**The information provided on this page represents TI's knowledge and belief as of the date that it is provided. TI bases its knowledge and belief on information provided by third parties, and makes no representation or warranty as to the accuracy of such information. Efforts are underway to better integrate information from third parties. TI has taken and continues to take reasonable steps to provide representative and accurate information but may not have conducted destructive testing or chemical analysis on incoming materials and chemicals. TI and TI suppliers consider certain information to be proprietary, and thus CAS numbers and other limited information may not be available for release.

In no event shall TI's liability arising out of such information exceed the total purchase price of the TI part(s) at issue in this document sold by TI to Customer on an annual basis.

## 重要なお知らせと免責事項

TI は、技術データと信頼性データ(データシートを含みます)、設計リソース(リファレンス・デザインを含みます)、アプリケーションや設計に関する各種アドバイス、Web ツール、安全性情報、その他のリソースを、欠陥が存在する可能性のある「現状のまま」提供しており、商品性および特定目的に対する適合性の黙示保証、第三者の知的財産権の非侵害保証を含むいかなる保証も、明示的または黙示的にかかわらず拒否します。

これらのリソースは、TI 製品を使用する設計の経験を積んだ開発者への提供を意図したものです。(1) お客様のアプリケーションに適した TI 製品の選定、(2) お客様のアプリケーションの設計、検証、試験、(3) お客様のアプリケーションに該当する各種規格や、その他のあらゆる安全性、セキュリティ、規制、または他の要件への確実な適合に関する責任を、お客様のみが単独で負うものとし、

上記の各種リソースは、予告なく変更される可能性があります。これらのリソースは、リソースで説明されている TI 製品を使用するアプリケーションの開発の目的でのみ、TI はその使用をお客様に許諾します。これらのリソースに関して、他の目的で複製することや掲載することは禁止されています。TI や第三者の知的財産権のライセンスが付与されている訳ではありません。お客様は、これらのリソースを自身で使用した結果発生するあらゆる申し立て、損害、費用、損失、責任について、TI およびその代理人を完全に補償するものとし、TI は一切の責任を拒否します。

TI の製品は、[TI の販売条件](#)、または [ti.com](#) やかかる TI 製品の関連資料などのいずれかを通じて提供する適用可能な条項の下で提供されています。TI がこれらのリソースを提供することは、適用される TI の保証または他の保証の放棄の拡大や変更を意味するものではありません。

お客様がいかなる追加条項または代替条項を提案した場合でも、TI はそれらに異議を唱え、拒否します。

郵送先住所 : Texas Instruments, Post Office Box 655303, Dallas, Texas 75265  
Copyright © 2024, Texas Instruments Incorporated